



3 1761 06707049 0



DR. HENRY A. LOOK  
PITTSBURG, PA.

Digitized by the Internet Archive  
in 2007 with funding from  
Microsoft Corporation

MCh  
K

# CYCLOPÆDIA

OF THE

# DISEASES OF CHILDREN

MEDICAL AND SURGICAL.

THE ARTICLES WRITTEN ESPECIALLY FOR THE WORK BY  
AMERICAN, BRITISH, AND CANADIAN AUTHORS.

EDITED BY

JOHN M. KEATING, M.D.

VOL. III.

ILLUSTRATED.

352130  
21. 6. 38.

PHILADELPHIA:

J. B. LIPPINCOTT COMPANY.

1890.

---

Copyright, 1890, by J. B. LIPPINCOTT COMPANY.

---



# CONTENTS OF VOLUME III.

## PART I.

### DISEASES OF THE DIGESTIVE SYSTEM.

	PAGE
<b>FUNCTIONAL DISORDERS OF THE STOMACH.</b> By WILLIAM PEPPER, M.D., LL.D., Philadelphia, Pa., Provost and Professor of Theory and Practice of Medicine in the University of Pennsylvania . . . . .	1
<b>DISEASES OF THE STOMACH.</b> By HOBART AMORY HARE, M.D., Philadelphia, Pa., Clinical Professor of Diseases of Children in the University of Pennsylvania; Physician to the Children's Dispensary of the University Hospital.	30
<b>THE DIARRHŒAL DISEASES, ACUTE AND CHRONIC.</b> By L. EMMETT HOLT, M.D., Professor of the Diseases of Children in the New York Poly-clinic; Attending Physician to the New York Infant Asylum and to the Babies' Hospital; Consulting Physician to the Hospital for the Ruptured and Crippled .	61
<b>MEMBRANOUS ENTERITIS.</b> By WM. A. EDWARDS, M.D., San Diego, California, formerly Instructor in Clinical Medicine and Physician to Medical Dispensary in the University of Pennsylvania; Fellow of the College of Physicians of Philadelphia, etc. . . . .	163
<b>INTESTINAL BACTERIA OF CHILDREN.</b> By WILLIAM D. BOOKER, M.D., Baltimore, Md., Professor of Diseases of Children in the Women's Medical College of Baltimore; Physician-in-charge of the Thomas Wilson Sanitarium for Sick Children, etc. . . . .	170
<b>ACUTE AND CHRONIC CONSTIPATION.</b> By CHARLES WARRINGTON EARLE, M.D., Chicago, Ill., Professor of Pediatrics and Clinical Medicine, Women's Medical College; Obstetrician and Gynæcologist, Cook County Hospital, etc. . . . .	191
<b>TABES MESENTERICA.</b> By A. JACOBI, M.D., New York, ex-President of New York Academy of Medicine; Clinical Professor of Diseases of Children in the College of Physicians and Surgeons, etc. . . . .	208
<b>PARASITES OF THE INTESTINAL CANAL.</b> By W. T. COUNCILMAN, M.D., Baltimore, Md., Associate Professor of Anatomy, Johns Hopkins University, etc. . . . .	217
<b>HERNIA IN CHILDREN.</b> By WILLIAM J. TAYLOR, M.D., Philadelphia, Pa., Surgeon to St. Mary's Hospital; Assistant Surgeon to the Orthopædic Hospital, etc. . . . .	231
<b>INTESTINAL OBSTRUCTION IN CHILDREN.</b> By W. W. KEEN, M.D., Philadelphia, Pa., Professor of Principles and Practice of Surgery, Jefferson Medical College; Surgeon to St. Mary's Hospital, etc. . . . .	247

	PAGE
<b>PERITONITIS.</b> By HENRY ASHBY, M.D., M.R.C.P., Manchester, England, Physician to the Hospital for Sick Children, Pendlebury, Manchester; Lecturer on Diseases of Children, Victoria University; Vice-President of the Section of Diseases of Children of the British Medical Association, 1888 . . . . .	268
<b>PERITYPHLITIS, PARATYPHLITIS, PERITYPHLITIC ABSCESS.</b> By CHRISTIAN FENGER, M.D., Chicago, Ill., Professor of Clinical Surgery, College of Physicians and Surgeons, Chicago; Attending Surgeon to the Cook County Hospital and to the German Hospital; Fellow of the German Surgical Association (Germany), etc. . . . .	282
<b>CONGENITAL ABNORMALITIES OF THE INTESTINE.—MALFORMATIONS, INJURIES, AND DISEASES OF THE RECTUM AND ANUS.</b> By HENRY R. WHARTON, M.D., Philadelphia, Pa., Surgeon to the Children's Hospital; Instructor in Clinical Surgery and Lecturer on Surgical Diseases of Children, University of Pennsylvania; Assistant Surgeon to the Hospital of the University of Pennsylvania . . . . .	315
<b>COLOTOMY.</b> By JOHN H. PACKARD, M.D., Philadelphia, Pa., Surgeon to the Pennsylvania and St. Joseph's Hospitals, etc. . . . .	357

#### THE PANCREAS.

<b>DISEASES OF THE PANCREAS, AND THEIR OPERATIVE TREATMENT.</b> By N. SENN, M.D., Milwaukee, Wis., Professor of Surgery, College of Physicians and Surgeons, Chicago; Surgeon to the Milwaukee Hospital, etc. . . . .	365
---	-----

#### THE LIVER.

<b>FUNCTIONAL DISORDERS OF THE LIVER, JAUNDICE, AND DISEASES OF THE DUCTS AND OF THE PORTAL VEIN.</b> By HENRY DWIGHT CHAPIN, M.D., New York, Professor of Diseases of Children at the New York Post-Graduate Medical School and Hospital and at the Women's Medical College of the New York Infirmary; Attending Physician to the Demilt Dispensary . . . . .	403
<b>ENLARGEMENTS OF THE LIVER.</b> By J. H. MUSSER, M.D., Philadelphia, Pa., Assistant Professor of Clinical Medicine, University of Pennsylvania; Attending Physician to the Philadelphia and Presbyterian Hospitals, etc. . . . .	422
<b>CONTRACTIONS OF THE LIVER.</b> By MARCUS P. HATFIELD, M.D., Chicago, Ill., Professor of Diseases of Children, Chicago Medical College; Physician to the Chicago Orphan Asylum; Member of the Council of Diseases of Children of the International Medical Congress, Washington, D.C., etc. . . . .	488

---

### PART II.

## DISEASES OF THE GENITO-URINARY ORGANS.

<b>ANOMALIES OF THE KIDNEY: NUMBER, FORM, AND POSITION.</b> By GEORGE B. FOWLER, M.D., New York, Professor of Clinical Medicine and Medical Chemistry, Post-Graduate Medical School and Hospital; Visiting Physician to Bellevue Hospital and the New York Infants' Asylum, etc. . . . .	516
<b>ALBUMINURIA IN CHILDREN.</b> By JAMES TYSON, M.D., Professor of Clinical Medicine in the University of Pennsylvania . . . . .	525



	PAGE
<b>ACUTE AND CHRONIC BRIGHT'S DISEASE.</b> By JAMES F. GOODHART, M.D., F.R.C.P., London, England, Physician to Evelina Hospital for Sick Children; Physician and Lecturer on Pathology in Guy's Hospital, etc. . . . .	532
<b>SURGICAL DISEASES OF THE KIDNEY.</b> By HENRY MORRIS, M.D., F.R.C.S., London, England, Lecturer on Surgery, Middlesex Hospital, etc. . . . .	559
<b>ENURESIS—INCONTINENCE OF URINE.</b> By A. JACOBI, M.D., ex-President of New York Academy of Medicine; Clinical Professor of Diseases of Children in the College of Physicians and Surgeons, etc. . . . .	591
<b>VESICAL, URETHRAL, AND PREPUTIAL CALCULI.</b> By WILLIAM HUNT, M.D., Philadelphia, Pa., Senior Surgeon to the Pennsylvania Hospital . . . . .	596
<b>MALFORMATIONS OF THE PENIS, URETHRA, AND BLADDER.</b> By DE FOREST WILLARD, M.D., Philadelphia, Pa., Clinical Professor of Orthopedic Surgery, University of Pennsylvania; Surgeon to the Presbyterian Hospital . . . . .	633
<b>DISEASES OF THE BLADDER.</b> By A. VANDER VEER, M.D., Albany, N.Y., Professor of Didactic, Abdominal, and Clinical Surgery, Albany Medical College; Attending Surgeon to Albany Hospital; Consulting Surgeon to St. Peter's Hospital, etc. . . . .	674
<b>DISEASES OF THE UMBILICUS.</b> By WILLIAM LEE, M.D., Baltimore, Md., Professor of Diseases of Children, Hygiene, and Dermatology, Baltimore Medical College, etc. . . . .	683
<b>DISEASES OF THE TESTES AND PENIS.</b> By F. R. STURGIS, M.D., New York, Surgeon to the Charity Hospital, Blackwell's Island, etc. . . . .	691
<b>DISEASES OF THE UTERUS, VAGINA, AND VULVA.</b> By JOHN M. KEATING, M.D., Philadelphia, Pa., Visiting Obstetrician to the Philadelphia Hospital; Gynæcologist to St. Joseph's Hospital; Consulting Physician for the Diseases of Women, St. Agnes' Hospital; Physician to the Children's Department, Howard Hospital, etc. . . . .	711
<b>DISEASES OF THE OVARIES AND TUBES.</b> By HOWARD A. KELLY, M.D., Baltimore, Md., Professor of Gynæcology at Johns Hopkins University, etc. . . . .	731
<b>ABNORMALITIES OF FEMALE GENITAL ORGANS AND MAMMARY GLANDS.</b> By CLARA MARSHALL, M.D., Philadelphia, Pa., Professor of Therapeutics in the Women's Medical College, Philadelphia; Visiting Obstetrician to the Philadelphia Hospital, etc. . . . .	741

---

## THE BLOOD.

<b>DISEASES OF THE BLOOD AND BLOOD-MAKING APPARATUS.</b> By J. P. CROZER GRIFFITH, M.D., Philadelphia, Pa.; Instructor in Clinical Medicine in the University of Pennsylvania, and Assistant Physician to the Hospital of the same; Physician to St. Agnes' and Howard Hospitals, to the Southern Home for Children, and to the Medical Clinic of the Children's Hospital . . . . .	755
---	-----

## PART III.

## SURGERY.

	PAGE
<b>MINOR SURGERY AND EMERGENCIES IN CHILDREN.</b> By CHARLES W. DULLES, M.D., Philadelphia, Pa., Surgeon to Out-Patients, University Hospital and Presbyterian Hospital, Philadelphia; Member of the Academy of Surgery, Philadelphia, etc. . . . .	839
<b>PLASTIC SURGERY.</b> By THOMAS G. MORTON, M.D., Philadelphia, Pa., Surgeon to the Pennsylvania Hospital, etc. . . . .	864
<b>WOUNDS</b> (including Contused, Lacerated, and Poisoned, and Complications, Pyæmia, Septicæmia, Erysipelas, Tetanus, Gangrene, Cellulitis, Lymphangitis, Hydrophobia, Poisoning from Venomous Reptiles and Insects, etc.). By JAMES McCANN, M.D., Pittsburg, Pa., Surgeon to the Western Pennsylvania Hospital; Professor of Surgery at the Western Pennsylvania Medical College, etc. . . . .	868
<b>ANÆSTHETICS AND ANÆSTHESIA.</b> By OSCAR H. ALLIS, M.D., Philadelphia, Pa., Attending Surgeon to the Presbyterian Hospital . . . . .	913

## PART IV.

## DISEASES OF THE OSSEOUS SYSTEM AND OF THE JOINTS.

<b>CONGENITAL ABNORMALITIES OF THE EXTREMITIES.</b> By THOMAS R. NEILSON, M.D., Philadelphia, Pa., Surgeon to the Episcopal Hospital; Instructor in Genito-Urinary Diseases and Assistant Demonstrator of Anatomy in the University of Pennsylvania, etc. . . . .	929
<b>CONGENITAL DISLOCATIONS.</b> By SAMUEL KETCH, M.D., New York, Visiting Orthopædic Surgeon to Randall's Island Hospitals, Department of Public Charities and Correction, New York City; Senior Assistant Surgeon to New York Orthopædic Dispensary and Hospital, and LE ROY W. HUBBARD, M.D., Senior Assistant Surgeon to the New York Orthopædic Dispensary and Hospital, etc. . . . .	945
<b>CLUB-FOOT.</b> By E. H. BRADFORD, M.D., Boston, Mass., Surgeon to the Children's Hospital; Surgeon to the City Hospital; Assistant in Clinical Surgery, Harvard Medical School, etc., and E. G. BRACKETT, M.D., Assistant Surgeon to the Out-Patient Department, Children's Hospital, etc. . . . .	955
<b>TORTICOLLIS.</b> By E. H. BRADFORD, M.D., Boston, Mass., Surgeon to the Children's Hospital; Surgeon to the City Hospital; Assistant in Clinical Surgery, Harvard Medical School, etc., and E. G. BRACKETT, M.D., Assistant Surgeon to the Out-Patient Department, Children's Hospital, etc. . . . .	979
<b>ACUTE INFLAMMATION OF BONE.</b> By WILLIAM MACEWEN, M.D., Glasgow, Scotland, Lecturer on Systematic and Clinical Surgery, Glasgow Royal Infirmary; Surgeon to Royal Infirmary and Children's Hospital . . . . .	992

	PAGE
<b>LATERAL AND FUNCTIONAL CURVATURES OF THE SPINE.</b> By V. P. GIBNEY, M.D., New York, Professor of Orthopædic Surgery at the New York Polyclinic; Surgeon-in-chief to the Hospital for Ruptured and Crippled, New York, etc. . . . .	1001
<b>POTT'S DISEASE.</b> By A. SYDNEY ROBERTS, M.D., Philadelphia, Pa., Vice- President of the American Orthopædic Association, etc. . . . .	1019
<b>FRACTURES AND DISLOCATIONS.</b> By JOHN H. PACKARD, M.D., Phila- delphia, Pa., Surgeon to the Pennsylvania Hospital and to St. Joseph's Hospital.	1043
<b>SYNOVITIS—ARTHRO-MENINGITIS.</b> By A. J. STEELE, M.D., St. Louis, Mo., Professor of Orthopædic Surgery and Joint-Diseases, St. Louis Post-Gradu- ate School of Medicine; Attending Surgeon to Department of Deformities and Diseases of the Joints, Augusta Hospital for Children; Professor of Orthopædic Surgery and Diseases of the Joints, Beaumont Medical College, etc. . . . .	1127
<b>DISEASES OF THE MAJOR ARTICULATIONS.</b> By CHARLES T. POORE, M.D., New York, Surgeon to St. Mary's Hospital for Children, New York, etc.	1139
<b>DISEASES OF THE MINOR ARTICULATIONS.</b> By D. A. K. STEELE, M.D., Chicago, Ill., Professor of the Principles and Practice of Surgery and Clinical Surgery, College of Physicians and Surgeons of Chicago; Attending Surgeon to Cook County Hospital; Ex-President of Chicago Medical Society, etc. . . . .	1252
<b>ANKYLOSIS.</b> By R. A. KINLOCH, M.D., Charleston, S.C., Professor of Sur- gery in the Medical College of the State of South Carolina; Surgeon to St. Xavier's Infirmary; Ex First Vice-President of the American Medical Associa- tion; Ex-President of the South Carolina Medical Association . . . . .	1266
<b>DEFORMITIES OF BONE. OSTEOCLASIS AND OSTEOTOMY.</b> By A. G. GERSTER, M.D., New York, Professor of Surgery, New York Polyclinic; Surgeon to the Mount Sinai and German Hospitals, etc. . . . .	1273
<b>MECHANICAL TREATMENT OF DEFORMITIES OF INFANTILE PARALYSIS.</b> By E. G. BRACKETT, M.D., Boston, Mass., Assistant Surgeon to the Out-Patient Department, Children's Hospital, Boston, etc. . . . .	1298
<b>AMPUTATIONS.</b> By WILLIAM BARTON HOPKINS, M.D., Philadelphia, Pa., Senior Surgeon to the Episcopal Hospital; formerly Professor of Clinical Sur- gery, Philadelphia Polyclinic . . . . .	1311



## LIST OF ILLUSTRATIONS TO VOLUME III.

### PLATES.

	PAGES
Case showing Area of Flatness on Percussion when the Stomach is distended . . . . .	between 44 and 45
Chart, Morbidity of "Cholera Infantum;" German Dispensary, New York, 1877-1887; 8036 Cases, and Average Monthly Temperature. (After Seibert) . . . . .	" 66 and 67
Chart, Mortality of Diarrhœal Diseases in Children under Five Years of Age; New York City, 1877-1887; 31,048 Cases, and Average Monthly Temperature. (After Seibert) . . . . .	" 66 and 67
Chart, Mortality of Diarrhœal Diseases in Children under Five Years of Age; Berlin, 1879-1883; 5131 Cases, with Mean Monthly Temperature. (After Baginsky) . . . . .	" 68 and 69
Chart, Mortality from Diarrhœal Diseases in Children under Five Years of Age; Baltimore, 1879-1887; 4390 Cases, with Mean Monthly Temperature (Warm Months only). (After Miller) . . . . .	" 68 and 69
Hyperplasia of the Lymph-Nodules (Solitary Follicles) of the Colon (Photo. I.) . . . . .	" 84 and 85
Enlarged Lymph-Nodules (Solitary Follicles) of the Colon (Photo. II.) . . . . .	" 84 and 85
Superficial Ulcers of the Colon (Photo. III.) . . . . .	" 84 and 85
Superficial Ulcers of the Colon (Photo. IV.) . . . . .	" 84 and 85
Deep Follicular Ulcers of the Colon (Photo. V.) . . . . .	" 84 and 85
Deep Sloughing Ulcers of the Colon (Photo. VI.) . . . . .	" 84 and 85
Croupous Inflammation of the Ileum (Photo. VII.) . . . . .	" 84 and 85
Chronic Hyperplasia of Lymph-Nodules of the Colon (Fig. 1) . . . . .	" 86 and 87
Lymph-Nodule of the Colon in the Early Stage of Ulceration (Follicular Ulcer) (Fig. 2) . . . . .	" 86 and 87
Deep Follicular Ulcer of the Colon (Fig. 3) . . . . .	" 86 and 87
Broad Superficial Ulcer of the Colon (Fig. 4) . . . . .	" 86 and 87
Acute Catarrhal Inflammation of the Ileum, Mild Form (Fig. 5) . . . . .	" 86 and 87
Acute Catarrhal Inflammation of the Ileum (Fig. 6) . . . . .	" 86 and 87
Acute Catarrhal Colitis, Severe Form (Fig. 7) . . . . .	" 86 and 87
Chronic Catarrhal Inflammation of the Ileum (Fig. 8) . . . . .	" 86 and 87
Croupous Inflammation of the Colon (Fig. 9) . . . . .	" 86 and 87
Poikilocytosis (Plate I., Fig. 1) . . . . .	" 764 and 765
Melanæmia (Plate I., Fig. 2) . . . . .	" 764 and 765
Blood in Relapsing Fever, showing the Spirillum (Plate I., Fig. 3) . . . . .	" 764 and 765
Blood in Leukæmia (Plate I., Fig. 4) . . . . .	" 764 and 765
Blood from Case of Leukæmia, showing Eosinophilous Cells.—Ocular, Zentmeyer A, Objective, Zeiss $\frac{1}{2}$ , Oil Immersion (Plate II., Fig. 8) . . . . .	" 788 and 789

	PAGE
Uterus Ineudiformis . . . . .	747
Uterus Septus Duplex . . . . .	748
Hæmoglobinometer of Gowers . . . . .	758
Hæmometer of Fleischl . . . . .	759
Hæmacytometer of Thoma-Zeiss . . . . .	760
Slide used in Counting Blood-Corpuseles . . . . .	761
Blood-Cells in Lipæmia . . . . .	765
Filaria Sanguinis Hominis . . . . .	767
Bilharzia Hæmatobia . . . . .	768
Photograph of Normal Blood . . . . .	813
Photograph of Blood in Pernicious Anæmia . . . . .	813
Artificial Respiration, Inspiratory Movement . . . . .	848
Artificial Respiration, Expiratory Movement . . . . .	848
Inhaler for Ether . . . . .	916
Mode of using the Inhaler . . . . .	917
Hypertrophy of Fingers . . . . .	932
Absence of Fingers . . . . .	935
Fusion of Digits . . . . .	935
Supernumerary Finger . . . . .	939
Supernumerary Thumb . . . . .	940
Supernumerary Toe . . . . .	940
Webbed Fingers . . . . .	942
Norton's Operation for Webbed Fingers . . . . .	942
Didot's Operation for Webbed Fingers . . . . .	943
Didot's Operation; Transverse Section of Fingers . . . . .	943
Noble Smith's Rod for Prevention of the Reunion of Fingers after the Operation for Webbed Digits . . . . .	943
Rubber Cord for Prevention of the Reunion of Fingers after the Operation for Webbed Digits . . . . .	943
Bilateral Congenital Dislocation of the Femora . . . . .	948
The same case, showing Bilateral Dislocation of the Heads of the Radii, etc. . . . .	948
Congenital Dislocation of the Tibia forward and outward . . . . .	951
Posterior view of the foregoing case . . . . .	951
Dorsal Surface of Club-Foot . . . . .	958
Normal Astragalus, and Astragalus from a Club-Foot . . . . .	959
Talipes Calcaneo-Valgus . . . . .	961
Beely's Apparatus for Equino-Varus . . . . .	965
The foregoing device applied . . . . .	966
Taylor's Club-Foot Shoe . . . . .	966
Taylor's Club-Foot Shoe applied . . . . .	967
Taylor's Club-Foot Shoe modified to prevent Inversion or Eversion of the Foot or Toes . . . . .	967
Lateral view of the foregoing . . . . .	967
Extreme Deformity from Equino-Varus; four views of the same case . . . . .	968
Morton's Apparatus for the Application of Extreme Force in Club-Foot . . . . .	973
Club-Foot in a Girl of Eighteen treated by Extreme Force . . . . .	974
Results in the foregoing case . . . . .	974
A Club-Foot treated by Extreme Force . . . . .	974
Result in the foregoing case, front view . . . . .	975
The same, side view . . . . .	975
Treatment of Club-Foot by the Excision of a Wedge-shaped Piece . . . . .	976
Flat-Foot; Whitman's Device for its Treatment . . . . .	977
The Usual Attitude in so-called Congenital Torticollis . . . . .	982
Torticollis of Several Years' Duration, front view and rear view . . . . .	983
Buckminster Brown's Appliance for Torticollis . . . . .	987
Padded Metal Plate applied in a Case of Torticollis . . . . .	987

	PAGE
Two Devices for Torticollis . . . . .	988
Two Views showing the Application of a Simple Device for Moderate Torticollis . . . . .	989
Case of Torticollis treated by an Operation . . . . .	990
After-Treatment of the foregoing case . . . . .	990
Results of Treatment in the foregoing case . . . . .	991
Rachitic Scoliosis in a Case of Genu Valgum . . . . .	1004
Rachitic Scoliosis to the Left, with Cyphosis . . . . .	1005
Case of Torticollis showing Cervico-Dorsal Scoliosis . . . . .	1005
Scoliosis from Empyema . . . . .	1006
Scoliosis dependent on Myositis Ossificans . . . . .	1006
High Dorsal Scoliosis from Infantile Cerebral Hemiplegia . . . . .	1007
High Dorsal Scoliosis dependent upon Paralysis resulting from Polio-Myelitis . . . . .	1007
High Degree of Scoliosis with Cyphosis, the Result of Paralysis from Polio-Myelitis . . . . .	1008
Lordosis with Slight Scoliosis in a Case of Paralysis of the Transversalis and Oblique, resulting from Polio-Myelitis . . . . .	1008
Diagram showing the Special Alterations in the Vertebrae in a Case of Spinal Curvature . . . . .	1009
Early Stage of Scoliosis in a Small Child . . . . .	1010
High Dorsal Scoliosis to the Right . . . . .	1011
High Dorsal Scoliosis to the Left . . . . .	1011
Lumbar Scoliosis to the Right, with compensating Dorsal Curve to the Left . . . . .	1011
The most common form of Scoliosis,—Dorsal to the Right . . . . .	1011
Dorsal Scoliosis to the Left in a Boy . . . . .	1012
Right Dorsal Scoliosis, the patient bending forward to show the amount of rotation . . . . .	1012
The Knight Brace for Lateral Curvature . . . . .	1013
Barwell's Dorso-Lumbar Bandage, posterior view . . . . .	1014
The same bandage, anterior view . . . . .	1014
Barwell's Rotation Bandage, posterior view . . . . .	1014
The same bandage, anterior view . . . . .	1014
Extensive Erosion of Dorso-Lumbar Vertebrae . . . . .	1021
Erosion of Lumbar Spine, Popliteal Abscess, without Deformity . . . . .	1022
Characteristic Hunchback Deformity . . . . .	1022
Marked Angular Curvature . . . . .	1022
Dorsal Caries . . . . .	1031
Functional Spinal Debility simulating Caries . . . . .	1032
Lumbar Caries . . . . .	1033
Davis's Spinal Assistant . . . . .	1039
Diagram showing the Principle of Davis's Support . . . . .	1039
Spinal Support with Chin-Rest . . . . .	1041
Ball-and-Socket Joint for Chin-Rest . . . . .	1041
Chin-Rest . . . . .	1041
Development of the Osseous System in a Child about Seven Months Old . . . . .	1043
The same in a Boy Four Years Old . . . . .	1044
The same in a Boy Ten Years of Age . . . . .	1044
Diagrams of Epiphyses (four figures) . . . . .	1051
Barton's Bandage applied . . . . .	1053
Pasteboard Splint for Chin . . . . .	1056
Pasteboard Cup for Jaw . . . . .	1056
Result after Multiple Fracture of Facial Bones . . . . .	1058
Fracture of Lower Part of Humerus . . . . .	1068
Pasteboard Splint for the above . . . . .	1069
Normal Relation of Arm and Forearm in Extension and Supination . . . . .	1073
Splint for Fracture near the Elbow . . . . .	1073
Coover's Splint . . . . .	1080
Splint for Fracture near Lower End of Radius . . . . .	1081
Levis's Splint . . . . .	1081

	PAGE
Hamilton's Apparatus for Fractures of the Femur in Children . . . . .	1087
Separation of Epiphysis of Femur . . . . .	1091
Separation of Lower Epiphysis of Femur, with Fracture . . . . .	1092
Weight-Extension acting as a Leverage in Disease of the Knee (four figures) . . . . .	1150
Diagram showing Abduction in Diseases of the Hip-Joint . . . . .	1163
Diagram showing Apparent Lengthening in Hip-Joint Disease . . . . .	1163
Diagram showing Adduction in Hip-Joint Disease . . . . .	1163
Diagram illustrating Apparent Shortening in Hip-Joint Disease . . . . .	1163
Case of Abduction in Hip-Joint Disease . . . . .	1166
C. F. Taylor's Appliances for Hip-Joint Disease (two figures) . . . . .	1178
Illustrations of Various Parts of Taylor's Hip-Splint (three figures) . . . . .	1179
H. L. Taylor's Instrument for Correcting Adduction . . . . .	1181
Thomas's Hip-Splint . . . . .	1183
The same in use (two figures) . . . . .	1184
Lovett's Apparatus for Hip-Joint Disease . . . . .	1184
Cross-Leg or Scissor-Leg Deformity (two figures) . . . . .	1187
Straight Incision over the Trochanter in Excision of Hip-Joint . . . . .	1198
Anterior Incision for Excision of Hip-Joint . . . . .	1201
Thomas's Splint for Tubercular Disease of Knee-Joint (two figures) . . . . .	1213
Method of Resection of Shoulder-Joint by a Single Straight Anterior Incision . . . . .	1243
Position of Posterior Incision for Resection of the Shoulder . . . . .	1243
Splint applied for Disease of Elbow-Joint . . . . .	1245
Long Median Incision for Excision of the Elbow . . . . .	1246
Gerster's Appliance for Use after Elbow-Excision; Wristlet and Arm-Band . . . . .	1247
View of the same fully applied . . . . .	1248
Robin's Osteoclast . . . . .	1276
Beely's Osteoclast . . . . .	1277
Ferrari's Osteoclast . . . . .	1278
Sayre's Knock-Knee Apparatus . . . . .	1278
Adams's Saw . . . . .	1281
Adams's Line of Section in Exsection of Hip-Joint . . . . .	1286
Sayre's Intertrochanteric Section . . . . .	1286
Gant's Subtrochanteric Section . . . . .	1286
Final Result after Cuneiform Excision of Knee for Ankylosis . . . . .	1287
Volkmann's T-Splint . . . . .	1288
Older Methods of Osteotomy for Knock-Knee (four figures) . . . . .	1290
MacCormac's and Macewen's Incisions in Supracondyloid Osteotomy . . . . .	1291
Genu Valgum before and after Operation (two figures) . . . . .	1292
Aggravated Case of Genu Valgum before and after Operation (two figures) . . . . .	1294
Extreme Contraction of Tendo Achillis . . . . .	1300
Stillman's Appliance for Pes Equinus and its Application . . . . .	1300
Taylor's Club-Foot Shoe . . . . .	1301
Tin Shoe for Club-Foot . . . . .	1304
Barwell's Appliance for Pes Valgus . . . . .	1305
Everted Foot with but little Displacement of the Arch . . . . .	1306
Appliance for Knee-Deformity, or for Loss of Power without Deformity . . . . .	1307
Apparatus for Paralysis of both Legs, with Marked Loss of Power . . . . .	1309
Stump after Amputation at the Shoulder-Joint (Figs. 1 and 3), . . . . .	1312
Stump after Amputation; Head of Humerus retained (Figs. 2 and 4) . . . . .	1312
Conical Stump in a Boy of Six Years Five Years after Amputation . . . . .	1312
Long Amputating Knife . . . . .	1313
Amputating Saw . . . . .	1313
Saw for Small Bones . . . . .	1313
Bone-Forceps . . . . .	1314
Flap-Needle . . . . .	1314
Incision for Metacarpo-Phalangeal Amputation . . . . .	1317



	PAGE
Result after Amputation of the Index-Finger with Removal of the Head of the Metacarpal Bone . . . . .	1318
The same, doing Needle-work . . . . .	1318
Lines of Incision in removing Thumb with its Metacarpal Bone . . . . .	1319
Stump after Removal of a Wedge-Shaped Piece from Central Portion of the Hand .	1319
Stump resulting from Amputation just below the Elbow . . . . .	1322
Stump after Amputation of Arm with Portions of Clavicle and Scapula . . . . .	1325
Foot after Removal of Second and Third Metatarsal Bones with their Toes . . . .	1325
Foot after Removal of Second Metatarsal Bone with its Toe . . . . .	1325
Formation of Plantar Flap in Lisfranc's Amputation . . . . .	1326

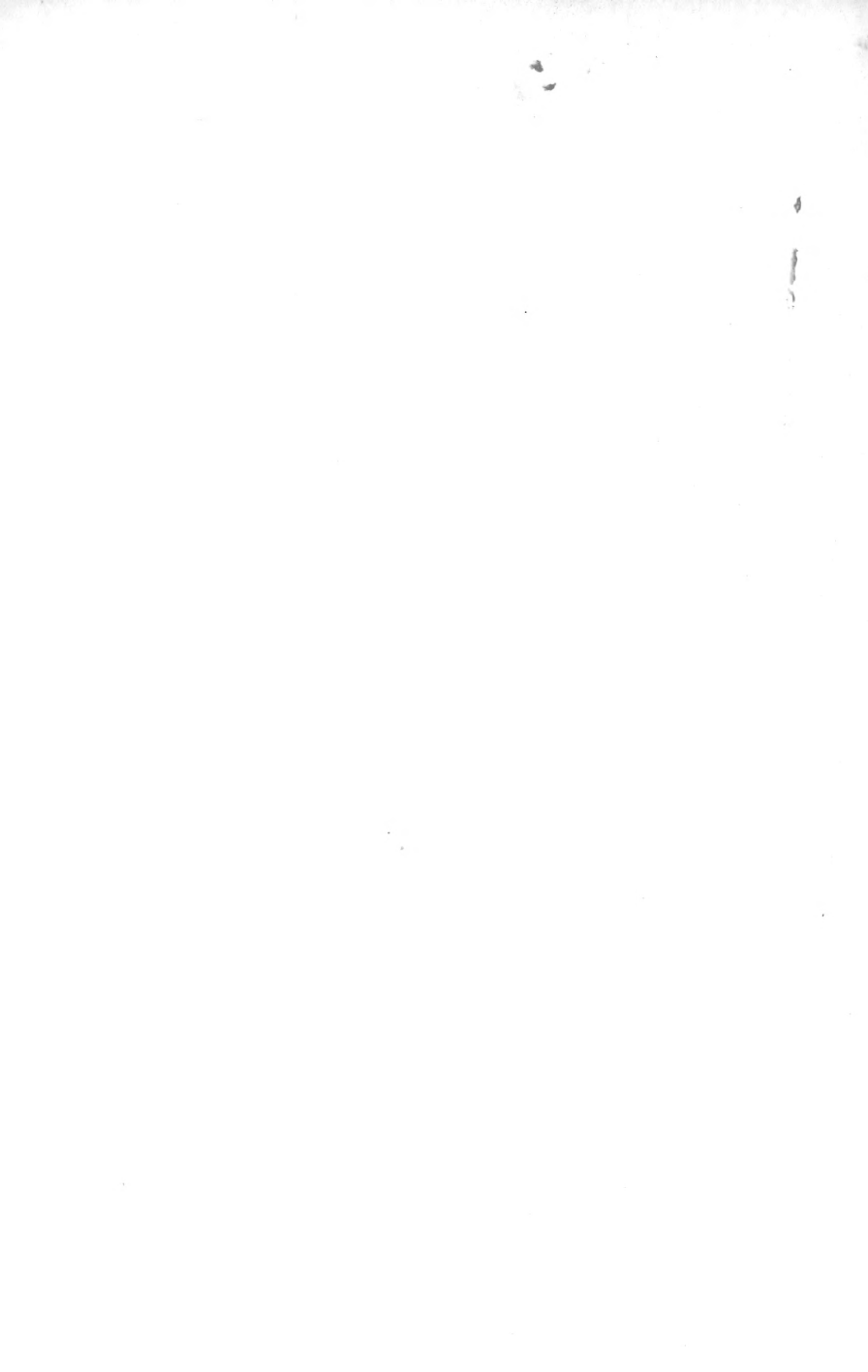

# CYCLOPÆDIA

OF THE

## DISEASES OF CHILDREN.

---

### PART I.

#### DISEASES OF THE DIGESTIVE SYSTEM.

---

#### FUNCTIONAL DISORDERS OF THE STOMACH.

BY WILLIAM PEPPER, M.D., LL.D.

---

##### DYSPEPSIA.

THE group of disorders included under this heading are by some called the indigestions; by others the term infantile atrophy is used to designate many of them; while others describe them as acute and chronic gastric or gastro-intestinal catarrh.

It embraces all those clinical conditions, frequently presenting complicated symptoms, which are dependent upon impaired gastric digestion, provided that there is no lesion of the stomach more serious than congestion or subacute catarrhal inflammation.

Mere defects in quantity or quality of the gastric secretions, without any appreciable change in the gastric tissues, may cause temporary indigestion. Anæmia or impaired innervation will suffice to explain it. But the more carefully the dyspepsias of young children are studied, the more closely will they be found connected with varying degrees of gastric catarrh. While, therefore, it is convenient to consider under a separate heading acute catarrh of the stomach, it would involve excessive repetition to discuss the chronic form after having described catarrhal dyspepsia. The frequency

of these disorders is even greater in children than in adults : they constitute by far the larger part of all chronic ailments in the former. The forms do not differ materially, but obviously it is less easy in children than in adults to classify individual cases of dyspepsia, as, for instance, atonic, nervous, or catarrhal. The chief reasons for this are the wide range of the sympathetic phenomena, the necessity of depending chiefly upon objective symptoms, the difficulty of studying critically the gastric secretions by means of lavage, and the frequency with which gastric catarrh sooner or later appears as an element in the case. Consequently, in this article the only division made will be into the acute and the chronic or habitual form of dyspepsia ; and under each of these attention will be called to the peculiarities which present themselves in infants and in older children.

**Causes.**—Defects of feeding are the most common causes ; but scarcely less important are errors in hygiene, especially concerning dress, exercise, bathing, and ventilation. Constitutional disorders, such as anæmia, rickets, scrofula, and lithæmia, often the result of inherited peculiarities, frequently act as predisposing causes. Close attention should be paid to the mode of action of these causes, as successful treatment invariably involves their detection and removal.

In suckling infants indigestion results chiefly, of course, from an unhealthy state of the milk of the nurse or from the premature use of artificial food. If the child has a wet-nurse the breast may be too old for the infant, or the health of the mother or nurse may be so poor that the quality of the milk suffers. It is not usual for the diet of a nursing woman to affect her milk materially, but it does in some cases ; and if the child has indigestion this question should be examined. Fixed rules cannot be laid down on this subject. It may even happen that the breast is of the right age, the nurse's health excellent, and the milk of apparently good quality, and yet, owing to some peculiarity of the digestive juices of the child, indigestion results.

The supply of milk is often scanty, and then, without evident dyspeptic symptoms, a process of wasting or atrophy ensues, which may be mistaken for the result of indigestion. On the other hand, the supply may be excessive, and, if the nipple delivers it freely or the child sucks vigorously, an undue amount is swallowed. Usually the surplus is promptly rejected ; and this form of vomiting or regurgitation is beneficial, and may avert the fermentation and gastric irritation which otherwise ensue.

More commonly the indigestion cannot be charged to the breast-milk, but is due to the fact that artificial food in undue proportion or of improper quality is given to the infant. Indeed, it seems a matter of wonder that more damage is not done, in view of the ignorant and reckless experimenting we often meet with. If the supply of breast-milk is actually scanty, the deficiency should be made up with cow's milk properly diluted and carefully sterilized. If, unfortunately, the mother cannot suckle her child, a wet-nurse is to be secured at once, if possible. If this is impracticable,

the artificial diet to be used should be prescribed by the physician in accordance with the principles elsewhere formulated.

In older children also, dietetic errors are frequent causes of dyspepsia. The mastication of the food now becomes of great importance. If this essential element in normal digestion is neglected, gastric disorder must sooner or later be induced. Irregularity of meals, undue variety of food, the premature use of tea, coffee, or spices, the unlimited use of ice-water, of fruit, or of sweets, the pernicious habit of eating candy, cake, or fruit between meals,—such errors are responsible for a vast amount of dyspepsia in childhood, and for an infinity of ill health subsequently.

But neither at this age nor in infants are dietetic errors to be regarded as the sole causes of the indigestions which are of such common occurrence. A vigorous stomach will tolerate much abuse even at an early age. But if the mucous membrane has been repeatedly congested, owing to sudden checking of the cutaneous circulation from imprudent exposure, from insufficient clothing, or from too rapid cooling of the body when overheated by play, a condition of weakness and irritability is developed which enables comparatively slight dietetic errors to produce severe symptoms, and which goes on rapidly to the establishment of subacute catarrh. It is enough to mention such causes to insure a recognition of their frequent operation.

It must further be remembered that at all periods of childhood there is great liability to the predisposing causes of dyspepsia. The inheritance of anatomical or physiological defects may show itself in this way. A scrofulous or gouty or rheumatic diathesis may dispose to faults of digestion and of assimilation. The neglect of sanitary precautions as to air, light, exercise, the depressing influence of dentition, and the exhausting drain of rapid growth and development, reduce nervous force and resisting power, and favor derangement of the complicated functions of digestion. The acute ailments and the specific fevers so common in childhood are apt to leave behind extreme sensitiveness of the system, and especially of the alimentary mucous membrane, even if a catarrhal process has not, as is often the case, been initiated. Such considerations indicate the varied nature of the causes of dyspepsia in childhood and impress strongly the need of constant vigilance to avoid its occurrence.

**Pathology.**—As already stated, there must be recognized in many cases of dyspepsia a state of lowered nervous force. This of itself may directly induce digestive failure, or it may merely serve to predispose thereto; while in all cases the nervous debility will be increased by the lack of assimilation and by the drain due to the prolonged reflex irritation. There exist also defects, quantitative and qualitative, in the gastric secretions, which are doubtless analogous to those with which we are becoming familiar from recent chemical studies in the dyspepsias of adults. There are marked and important variations in the blood-supply, and in the tonicity of the gastric walls and especially of the muscular layer. Lastly, and most serious of all, there are the lesions of catarrhal inflammation. The mucous mem-

brane becomes congested in patches: it is somewhat thickened, and in some cases the follicles are enlarged so as to give an appearance of slight roughness to the surface when viewed obliquely. The consistence of the membrane may be diminished, though much care is needed to avoid confounding this with the results of post-mortem maceration, which explains most of the softening of the stomach. On the other hand, in severe cases of long-standing catarrh the mucous membrane is of a grayish or light slate color and may be thicker and firmer than normal. The secretion of mucus is increased; the surface is covered with thick and tenacious layers of it. On the other hand, the gastric juice is apt to be lessened in amount, or at least to be deficient in peptic strength. The impairment of the muscular tone of the walls, and the fermentation of the mucus and food which the stomach contains, often induce dilatation even to marked degrees.

**Symptoms.**—Acute or accidental indigestion in infants causes weakness, with pallor of the face, and restlessness, with moaning cries or with screaming at the least disturbance. The skin may be hot and dry, or there may be nausea, with a relaxed, cool surface. Sleep is broken and restless. The abdomen is distended with flatus and the epigastrium is tender. Vomiting of sour, curdled milk occurs, and is followed by relief. The attack may be cut short when the stomach is thus emptied; but if the irritation of the mucous membrane is greater, vomiting will continue, and the matter rejected, with painful retching, will consist of bile-stained, watery mucus. Some elevation of temperature ( $101^{\circ}$  or  $102^{\circ}$  F.) will occur in these cases for a short time. The bowels are usually constipated, but towards the close of the attack some diarrhoea may occur, either because undigested food has passed into the intestines or because the intestinal mucous membrane also has been affected by the imprudent exposure which produced the attack. The symptoms subside in from twenty-four to sixty hours, but the stomach remains sensitive for a few days longer.

In older children these attacks may be more severe, especially if, in addition to the irritation caused by indigestible and fermenting food, there are, as so often happens, congestion and catarrh of the stomach produced by atmospheric influences. To these more serious attacks a separate section is devoted, under the heading of Acute Gastric Catarrh (see page 33).

There are, however, many mild cases, of short duration and with slight general disturbance. Within a few hours or a day after eating excessively or imprudently, the child becomes languid and chilly, grows drowsy, and complains of headache and pain in the stomach. If vomiting, fortunately, occurs, the attack may be promptly broken up, just as in infants. But if the offending matters are retained, fever ensues, with rapid, bounding pulse, hot, dry skin, tender, full epigastrium, coated tongue, and marked thirst. The bowels are constipated; the urine is scanty, high-colored, and turbid. Such symptoms gradually subside, the stomach regains its tone, and appetite returns: the child remains weak and pale for a few days, but regains its usual health in the course of three to six days. If the child has a predisposition

to convulsions, such attacks may induce them. I have known a number of children who for several years had occasional spells of acute dyspepsia, and had one or more convulsions with each such spell, until by the adoption of suitable hygienic rules the disturbances of digestion were avoided and the convulsions did not recur. In certain families this association has shown itself in several children successively, in consequence either of undue nervous mobility or of a tendency to lithæmia with the production of irritating ptomaines. These severe nervous symptoms may attend gastric attacks of apparent mildness. They are due more to the predisposing tendency than to the gravity of the exciting cause.

Chronic dyspepsia or habitual indigestion occurs likewise at all ages. It may exist almost from birth, or come on insidiously at a later date; but in many cases it is preceded by a series of attacks of acute indigestion, occurring at shorter and shorter intervals and induced by milder and milder causes as the resisting power of the system is reduced and the mucous membrane of the stomach becomes more constantly the seat of catarrhal irritation, with impairment of its functions.

The effect upon the child varies much, according to the amount of nourishment which, though with difficulty and distress, is extracted from the food ingested. Some children despite marked dyspeptic symptoms grow fairly well, though they become pale and flabby. But others are unable to keep pace with the demands on their nutrition, and grow thin, with pinched cheeks, projecting cheek-bones, and small muscles, though the abdomen may appear full, owing to flatulent distention. The most extreme degrees of atrophy or wasting are seen in puny infants who are fed on an insufficient amount of milk with large admixture of inappropriate starchy food. Still, we may encounter in older children startling degrees of emaciation, such as Gull has described under the name of *anorexia nervosa*, dependent solely upon chronic catarrhal dyspepsia.

Young infants with habitual indigestion sleep badly, are peevish, and often cry violently: they are especially restless and troublesome at night. The skin is pale, wrinkled, and not rarely presents eruptions. The extremities are cool; the fontanel is level or depressed. The appetite may be impaired, so that the child can be fed only with great difficulty; or there may be a craving thirst or appetite which leads him to take ravenously whatever is offered, even though its reception quickly causes increased gastric distress, with painful colic, nausea, or vomiting. The tongue is not so characteristically affected as in older children: usually it is moist, flabby, and coated whitish. The bowels are apt to be constipated, as a rule; and the movements may be abnormally dry and hard, so as to be expelled with effort and pain. From time to time short spells of diarrhœa occur, and then the stools are of partly-undigested food, bile-stained and with an increased amount of mucus. Vomiting is an almost constant symptom, but varies greatly in character and frequency. It may occur but occasionally, when the stomach gets overloaded, or when the food disagrees more than commonly; or it may be the

most troublesome and dangerous symptom. The acts of vomiting are very frequent: as soon as food is taken, more or less of it is rejected, and in the intervals bile-stained, watery mucus is thrown up. Such spells of persistent vomiting require prompt and judicious treatment. They are very debilitating, and, unless checked, the familiar hydrocephaloid symptoms of cerebral anæmia and exhaustion may appear and be followed by death.

The symptoms of habitual indigestion in older children are analogous to those observed in the adult. With a varying amount of malnutrition and interference with growth, or of actual emaciation, the appearance is one of languor, weakness, and debility. The child is indifferent to play, or else plays violently and spasmodically and soon grows weary. The temper is perverted, irritable, and uncertain. The breath is heavy and unpleasant. The tongue is usually large, flabby, tooth-marked, and covered with a coating white and thin in front and thicker and more yellowish towards the base, while the papillæ are enlarged, reddened, and prominent. In some cases the tongue presents denuded areas of limited size and circular or irregularly curved in shape, which may be seated in the centre or on either half of the organ. The appetite is variable, and often perverted. There is feeble or absent desire for suitable food at usual hours, while the child craves sweets or highly-seasoned articles at odd times. There may even be genuine boulimia, with insatiate craving for all sorts of food, and even when large amounts have been taken there is no sense of relief or satisfaction. The irritation is often referred to the nostrils or to the anus, so that the child is instinctively and uncontrollably picking the nose or clutching at his seat. In accordance with tradition, such symptoms are held to denote the presence of intestinal worms; and, in fact, it is by no means rare for ascarides to appear in such cases.

Nausea is often complained of, or may be determined to exist by the expression of face and the attendant debility and relaxation in children too young to interpret their sensations. Vomiting is much less common than in the habitual indigestion of infants; but from time to time there is apt to be an exacerbation of the catarrh, from some atmospheric or dietetic cause, and then the stomach grows more irritable and vomiting occurs. The matters rejected are acid, and composed of partially-digested fermenting food, with tenacious glairy mucus. There is no reason to doubt that the chemical changes in the gastric contents are similar to those found in adults suffering with the various forms of dyspepsia, although this question has not yet been fully studied in children. There seems to be, however, an especial tendency to loss of peptic strength from failure in the secretion of the digestive principles, and to hyperacidity, probably more from the development of secondary organic acids than from excess of hydrochloric acid. When the obstacles to removal of gastric contents by lavage can be overcome, it is important to secure careful chemical and microscopical examinations. I must state, however, that in my own experience, in private practice, it has proved



very difficult to use lavage in young children, for purposes either of diagnosis or of treatment.

The bowels are habitually constipated, and the stools present unhealthy appearances. Several days may intervene between passages, which consist of a few hard balls, clayish or party-colored, and smeared with stringy mucus. In such cases the intestinal secretions are scanty, the abdominal and intestinal walls are weak, and the colon and its pouches are dilated. Or, on the other hand, the stools may be of mushy consistence, and present under the microscope many fragments of undigested food and many oil-globules. Indeed, it is impossible to describe all the variations, since the gastric disorder is so often associated with similar morbid conditions of the intestines, and since the intercurrent attacks of renewed gastric irritation are usually attended with more or less intestinal catarrh.

Flatulence is a constant symptom. There may be eructations; the belly is distended, and there are frequent colicky pains. The fulness may be limited to the epigastrium or be general and so considerable as to make the body contrast sharply with the thin features and limbs. Dilatation of the stomach is a common attendant upon this atonic type of dyspepsia if severe and long continued. It may be expected to occur in a moderate and unimportant degree, but extreme care must be used to avoid mistaking mere flatulent distention of the stomach and intestines for true persistent and organic dilatation. The reader is referred to the account of this latter condition (see page 41); but, as there shown, it is by no means rare for such dilatation even of high degree to develop in the course of chronic gastric catarrh, especially in rachitic children and in those who have marked nervous adynamia and muscular atony. I am disposed to attach a far greater degree of importance than is usually assigned to this condition in the dyspepsias, catarrhal and atonic, of children, both as regards the production of symptoms and as affecting the results of treatment.

Pain is present in most cases. It may be only a sense of distress referred vaguely to the abdomen, and varied by spells of acute flatulent colic occurring a couple of hours after meals. Or the neurotic or neuralgic element may be much more prominent, and violent paroxysms of abdominal pain may occur at irregular intervals, which must be regarded as gastralgia or enteralgia. It will, of course, be remembered that young children are often unable to locate sufferings, so that it may be necessary to determine the seat of pain by exclusion,—by a study of the physiognomy and movements; just as, on the other hand, I have repeatedly known the pain of pleurisy or of rheumatic pericarditis to be referred to the abdomen by the little sufferer. In children, as in adults, there are dyspepsias which deserve the name of nervous, from a mere clinical stand-point, on account of the predominance of the symptoms of local or reflex nervous irritation. In addition to the neuralgic paroxysms above mentioned, there occur in different cases reflex disturbances of the heart's action, spells of extraordinarily rapid breathing, due to a species of palpitation of the diaphragm, attacks of syncope, closely

The first part of the book is devoted to a general history of the United States from its discovery by Columbus in 1492 to the present time. It covers the period of the discovery, the early settlement, the struggle for independence, and the formation of the Union.

The second part of the book is devoted to a detailed history of the United States from the year 1776 to the present time. It covers the period of the American Revolution, the formation of the Constitution, the early years of the Republic, and the present state of the Union.

The third part of the book is devoted to a detailed history of the United States from the year 1776 to the present time. It covers the period of the American Revolution, the formation of the Constitution, the early years of the Republic, and the present state of the Union.

The fourth part of the book is devoted to a detailed history of the United States from the year 1776 to the present time. It covers the period of the American Revolution, the formation of the Constitution, the early years of the Republic, and the present state of the Union.

The first part of the report is devoted to a general survey of the conditions of the country during the year 1900. It contains a summary of the principal events of the year, and a description of the general state of the country. It also contains a list of the principal cities and towns, and a description of the principal industries and occupations of the country.

The second part of the report is devoted to a detailed description of the principal cities and towns of the country. It contains a description of the principal streets, public buildings, and other important features of each city and town. It also contains a list of the principal occupations and industries of each city and town, and a description of the principal educational institutions of each city and town.

The third part of the report is devoted to a detailed description of the principal industries and occupations of the country. It contains a description of the principal manufacturing industries, and a description of the principal agricultural and stock-raising industries. It also contains a list of the principal occupations and professions of the country, and a description of the principal educational institutions of the country.

mouth, the enlargement of the spleen, and the information elicited from the parents, will nearly always enable a diagnosis to be made. It is especially important to decide this question without having recourse to the therapeutic test of specific treatment, since effective doses of iodide of potassium or of any preparation of mercury are likely to be injurious if the case is not syphilitic. Still, I have met with cases where, after the most careful balancing of probabilities, a degree of doubt remained which could be dispelled in no other way than by an experimental course of antisyphilitic medication. I should advise mercurial inunctions in such cases, in preference to remedies administered internally.

When tuberculosis occurs in the infant, the temperature is elevated, and the thermometer in the rectum will show a maximum in the evening or morning (for the febrile movements of young children frequently reach the highest point in the morning) of  $101^{\circ}$  or  $103^{\circ}$  F.; there are apt to be signs of pulmonary trouble at least in the form of scattered râles or areas of altered respiratory murmur; and diarrhoea commonly ensues, owing to tuberculosis of the intestinal mucous membrane. These symptoms clearly distinguish it from ordinary infantile atrophy, which is attended with no elevation or even with a depression of temperature. Yet it is evident that such infants are liable to more or less wide-spread catarrh, and that when this affects the bronchial and intestinal mucous membrane a condition develops which will closely simulate tuberculosis. The absence of sputa, and the unsatisfactory result of microscopic search for tuberculous bacilli in the stools, further increase the difficulty of positive diagnosis, until the temporary aggravation of the dyspeptic symptoms has subsided.

In older children chronic dyspepsia is usually recognized with ease. The commonest error in diagnosis is undoubtedly the failure to detect the gastric origin of certain reflex symptoms or of the disturbances of general health. Allusion has already been made to the question which is almost sure to be raised as to the possibility of explaining the symptoms by the presence of intestinal worms. It will not suffice to give assurances that if worms are present they are to be regarded as the result of defective digestion rather than as the cause of the symptoms present. Nor must it be forgotten that in certain cases intestinal parasites do actually cause decided and varied symptoms. It may be altogether proper, therefore, to eliminate this element by the administration of efficient but unirritating vermifuges.

Careful examination must always be made of the heart and of the urine, since cardiac and renal diseases are as fruitful sources of indigestion in children as in adults. Cirrhosis of the liver in children is so rare that it is enough to refer to it with the remark that during its earlier stages the more evident symptoms are those of gastric congestion and catarrh. But hepatic congestion and catarrh are, on the other hand, of frequent occurrence in childhood, and have close relations with the dyspepsias. The affection of the liver may be primary and the gastric disorder secondary and dependent. But much more frequently the trouble has arisen as a gastro-duodenal

catarrh which has invaded the bile-ducts more or less deeply. This is the usual significance of jaundice when occurring in dyspeptic children; and in many cases it is necessary to appreciate the coexistence of hepatic irritation even when no such decided symptoms as jaundice have been produced. The diagnosis of gastric ulcer and of dilatation of the stomach is considered under these respective headings.

In severe cases, with marked impairment of general health, with frequently-recurring spells of fever and increased catarrhal irritation, with attenuated features and limbs and distended abdomen, and especially with the addition of bronchial catarrh easily explicable by the undue sensibility of the system, the fear of tuberculosis is likely to arise. A correct diagnosis may, however, be made by careful attention to the history of the case and to the sequence in which the symptoms have appeared; to the facts that the recurring spells of increased catarrh can be traced to definite atmospheric or dietetic causes, and that the fever is proportionate in intensity and duration to the gastro-intestinal irritation, and in the intervals between the spells disappears or is marked only by a trifling rise in the morning or evening; to the peculiar changes presented by the tongue, by the matters vomited, and by the stools; to the fugitive and shifting character of the physical signs of chest-trouble; to the absence of splenic enlargement, which often occurs in tuberculosis; and, finally, to the gratifying results of proper hygienic and medical treatment.

**Prognosis.**—Dyspepsia in children, when primary and unassociated with organic disease, yields to treatment, as a rule. There are, however, infants who have inherited such feeble vitality and digestion that it is well-nigh impossible to save them; nor, if their lives are spared, do they ever attain vigorous health. Trifling intercurrent affections may abruptly cut short the course of habitual indigestion in such frail subjects. There are at times unfavorable hygienic conditions, beyond the power of the physician to rectify, which will defeat the most judicious treatment, so that the case advances to hopeless atrophy and vital exhaustion.

An excessive mobility of the nervous system may allow convulsions to result from the gastric irritation, and serious or even fatal consequences may follow. The protracted disorder of nutrition, especially in the more severe cases of gastro-intestinal catarrh, may invite the development of a tuberculous tendency, and exposes the child to the danger of attacks of jaundice, of nephritis, or of catarrhal pneumonia. The acute infectious diseases are not necessarily more severe or fatal in children suffering thus than in those enjoying vigorous health.

While, therefore, the dyspepsias of children are not of themselves often fatal, they are serious on account of the vulnerability of system they induce; they are prone to recur; and they are apt to interfere with normal development and to entail subsequent debility of digestion, of nerve, or of the entire nutrition.

**Treatment.**—Some of the important questions connected with the

management of indigestion in the infant and in the older child cannot be adequately treated here, owing to want of space. No attempt will, for instance, be made here to discuss exhaustively all the details of the hygienic and dietetic management which is essential to prevent disorders of digestion, and which constitutes the most important part of the treatment of these disorders when they have, unfortunately, been allowed to develop. It is not too much to assert that when strict and intelligent care is used, and when the environment is reasonably favorable, the task of keeping in order the digestion of infants, whether suckled or fed artificially, and of children at all ages, is a comparatively easy one. But neither the prevention nor the cure of the dyspepsias will be possible unless the principle is clearly appreciated and persistently applied that minute attention to every detail of life—dress, bathing, ventilation, rest, and exercise, as well as diet—is the price of success in managing children.

The treatment of acute dyspepsia or occasional indigestion in infants is very simple. Sufficient vomiting has usually occurred before the child is seen by the physician, and the only indication is to allay gastric irritation and to prevent exhaustion. The child should be held quietly upon the lap or placed in bed, the room darkened, and everything avoided which can arouse the attention. After each act of vomiting there may be such signs of relief that the nurse is encouraged to try to amuse the child; but all such interference is exhausting and helps to induce further spells of vomiting. A small mustard plaster weakened with flour, a spice plaster, a warm mush poultice, or a flannel cloth wrung out of hot water and spirit, should be applied over the stomach. For some hours there is no desire for food; and no attempt should be made to force feeding. Thirst may be allayed by scraps of ice, or by a few drops of a mixture of equal parts of lime-water and cinnamon-water, or of milk and lime-water, given at short intervals. This will also serve to settle the stomach, and gradually the amount may be increased as the child can take and retain it.

But if vomiting persists it is worse than useless to persist with efforts to administer food. An enema of one to four teaspoonfuls of tepid water containing a proper amount of deodorized tincture of opium (from one-half drop upward, according to the age) should be given to allay restlessness and irritability. The infant will, as a rule, promptly return to the breast or to its usual food as soon as the vomiting is allayed. Should the child continue restless and fretful, with coated tongue, and full and tender belly, it is due to the passage of fermenting and indigestible food into the bowels. Under these circumstances, an evacuation should be encouraged, either by a suppository of gluten or glycerin, or by a simple laxative, if the stomach be prepared for it, of castor oil in delicate emulsion, or of calcined magnesia in spiced syrup of rhubarb.

In older children it more frequently happens that the stomach does not at once reject all of the offending matters: so that if vomiting has not occurred, or seems to have been inadequate, it is important to secure the

full evacuation of the stomach by draughts of warm water or by ipecacuanha. This preliminary is too often neglected; but, on the other hand, nothing must be given which can increase the already existing irritation. The attack is, as we have seen, likely to be attended with fever, and may be protracted for several days. The child is, therefore, to be at once put to bed and to be strictly confined there until fully convalescent. Counter-irritation at the epigastrium by mustard or iodine is useful. Food is to be withheld entirely for several hours. If the stomach remains irritable and non-retentive after that, it may be well to give nutritious enemata, especially if the child is delicate. The chief indications are to allay gastric irritation, to prevent fever, and to promote gentle action of the bowels. If the febrile reaction seems likely to be marked, it is well to give, every two hours, small amounts of freshly-prepared effervescing draught, each dose containing a fraction of a drop of tincture of aconite root; or of liquid effervescing citrate of magnesia (℥ $\overline{5}$ ss to ℥ $\overline{5}$ i). If the stomach does not retain these, and especially if the tongue is heavily coated, it is better to resort to divided doses of calomel (gr.  $\frac{1}{10}$  to gr.  $\frac{1}{12}$ ) mixed with minute amounts of bicarbonate of sodium, subnitrate of bismuth, or sugar of milk. One such powder may be placed dry on the tongue every second hour; and at the intervening hour a dose of aconite (gtt.  $\frac{1}{4}$  to gtt.  $\frac{1}{2}$ ) may be given in a teaspoonful of hot water or of iced carbonic-acid-water. The laxative action of these remedies is to be promoted by a suppository of gluten or glycerin or by a laxative enema. Desirable as it is to secure a movement of the bowels, it must be remembered that, in the exquisitely sensitive state of the stomach, any active laxative in ordinary dose would inevitably increase irritation and prolong the case.

As the stomach grows settled, food is to be given at first in teaspoonful doses of milk and lime-water or of milk and carbonic-acid-water, repeated at short intervals. Gradually the amounts can be increased, light broths added, and thus a return to ordinary diet slowly effected. Any tendency to marked nervous symptoms, such as severe headache, or excessive restlessness, or twitching or jerking of the muscles, should be controlled by an enema of chloral hydrate (gr. v in ℥ $\overline{5}$ i of water at three years of age) with or without bromide of potassium or laudanum associated. If there is high fever, attended with such symptoms, a warm bath will exert a soothing influence; and a dose of effervescing granulated sodium salicylate and antipyrin (℥i = āā gr. ii) in a small amount of water will act promptly and most agreeably. For some days after the attack, unusual care is to be observed as to diet, exercise, and exposure; and it is well to administer a digestive tonic, such as

℞ Fairchild's essence of pepsin,  
Fairchild's diastatic pancreatic extract, āā, ℥ $\overline{5}$ iss.

M. S.—From one-half to one small teaspoonful in a little water after meals.

Or

℞ Elix. bismuth, pepsin, and strychnine.  
S.—From fifteen to thirty drops in water after meals.

Or

R Quininae sulph., gr. xii ;  
 Strychninae, gr.  $\frac{1}{4}$  ;  
 Acidi sulphurici aromatici, fʒi ;  
 Curaçoa vel Elix. simplicis, fʒiii ;  
 Aquae purae, q. s. ad fʒiii  
 Ft. sol.

S.—From thirty to sixty drops in water after meals.

These doses, as is the case with all others suggested in this article, are adapted to children of from three to seven years.

In the treatment of the habitual indigestion of infants, the first thing demanded is a careful study of the diet. If the child is still nursing, the breast-milk must be examined critically as to quantity and quality. If decided defects are found, it is desirable to lose no time in securing another breast of milk, if possible. But it may happen that the infant cannot or will not suckle, or that the best breast-milk disagrees. The child must then be weaned, and the problem of artificial feeding is presented. It is best in all cases to have recourse to cow's milk, carefully selected, and properly diluted with water, lime-water, or barley-water. For an infant a few months old the milk should not be more than one-half strength, and if this disagrees the proportion of milk should be further reduced. Often the simple fact that the milk is properly diluted and is administered in small quantities at proper intervals will put a stop to the vomiting and the infant will begin to improve. But if the food continues to ferment, and vomiting and distress still occur, a mixture of whey fʒi, fresh cream fʒss, and water fʒi, may be tried, or a mixture of strippings (obtained by re-milking the cow) with water; or delicate broths made of chicken, veal, or beef, and mixed with equal amounts of rice- or barley-water. In cases of this kind, a diet consisting of gelatin, milk, cream, and arrow-root, as recommended in Meigs and Pepper on Diseases of Children, may be found to suit better than anything else. The amount to be given at each feeding must be carefully adapted to the age, and to the digestive power of the stomach. The food must be prepared with great care, and be kept so as to avoid all risk of contamination or of fermentation. It cannot be doubted that the process of sterilizing all milk used in the preparation of artificial food for infants is highly important as excluding micro-organisms and fermentation, while at the same time it permits a larger amount of the food to be prepared at once and thus saves much trouble.

It is equally essential to promote healthy action of the skin, and thoroughly to protect the body by proper clothing from undue atmospheric influences. Bathing should be replaced by sponging the body daily with warm water, to which a very little ammonia or salt or alcohol may be added. This is to be followed by gentle but thorough inunction with olive or cod-liver oil. It is doubtful whether the latter has any greater value to compensate for the offensive odor which it imparts. But there can be no doubt as to the positive beneficial effect of such inunctions when used



perseveringly. A light flannel binder is to be kept around the abdomen. The infant is to be dressed from neck to toes in woollen garments of appropriate weight.

When this is done it is possible to keep the temperature of the room down to 69° or 70° F., and to admit fresh air so as to keep the apartment pure and healthy. This is far safer and better than to have the body-clothing too light for protection and to depend upon extra wraps and upon keeping the room very warm. The little child is rendered more tender and susceptible, and the utmost care is unable to avoid draughts and changes of temperature which will then certainly give colds.

The main indications for the administration of medicines are to allay vomiting, to improve digestion, and to promote nutrition. It is needless to say that all medication is secondary to dietetics and hygiene, and that the remedies selected must be given cautiously, in small doses, and in palatable forms. It is often found, even when it could scarcely be expected, that cod-liver oil is well received and digested. It then proves of the utmost value, and remarkable improvement follows its use. It is best given in the form of a delicate freshly-made emulsion with lacto-phosphate of lime, as follows :

R Ol. jec. aselli, ℥ $\frac{5}{8}$  iss ;  
 Calcis lacto-phosphatis, gr. xxxii ;  
 Pulv. acaciæ,  
 Sacchari lactis, āā, q. s. ;  
 Ol. cinnamomi vel Ol. gaultheriæ, gtt. iii ;  
 Aquæ puræ, q. s. ad ℥ $\frac{5}{8}$  iv.  
 Ft. mist. sec. art.

S.—A teaspoonful three times daily for an infant four months old.

It must not be imagined that even the most delicately prepared emulsions will always be received. On the contrary, there are cases where the most minute amount will disagree. It may be found then that extremely small doses of arsenic will do better : as, for instance,—

R Liq. arsenici chloridi, gtt. xvi ;  
 Acidi muriatici diluti, gtt. xvi ;  
 Aquæ cinnamomi, q. s. ad ℥ $\frac{5}{8}$  iv.

M. S.—From twenty to sixty drops in a teaspoonful of water after food, three or four times daily.

Or if an alkaline preparation be preferred,—

R Liq. potassæ arsenitis, gr. xvi ;  
 Sodii bicarbonatis, gr. xxxii ;  
 Aquæ cinnamomi, q. s. ad ℥ $\frac{5}{8}$  iv ;

M. S.—From twenty to sixty drops in a teaspoonful of water after food, three or four times daily.

Other aromatic waters may be used as the vehicle, or it may answer better to use simple distilled water.

These remedies have the advantage that if they act favorably on the mucous membrane they will exert a good influence upon the general nutri-

tion. But it often happens that even these small doses of arsenic cause irritation, or at least do not allay that which already exists.

There is no remedy which can be given, even to the youngest infants, with more confidence than nitrate of silver in those cases where the gastric irritability is excessive, so that vomiting is a chronic condition. The dose must be very small, at the beginning at least, as, for instance :

℞ Argenti nitratis, gr.  $\frac{1}{2}$ ;  
Aquæ destillatæ, f℥v.  
Ft. sol.

S.—From thirty to sixty drops in a teaspoonful of water to a child six months old, four times daily, on an empty stomach.

Indeed, in all the catarrhal affections of the gastro-intestinal mucous membrane in children this remedy possesses remarkable value, although it requires great tact to determine the dose and the frequency and times of administration best adapted to each case.

From time to time, in spite of strict care, exacerbations of the symptoms may occur; and it will then be well to omit the standard remedies and to use a brief course of minute doses of calomel (gr.  $\frac{1}{20}$  to gr.  $\frac{1}{12}$  every two hours), followed for a few days by drop doses of wine of ipecac every four hours, or by powders containing,—

℞ Pepsin. (saccharated),  
Bismuth. subnitratis, āā, gr. x ad gr. xx.  
M. et div. in chart. xx.  
S.—One three or six times daily.

Throughout the course of the case the degree of weakness may be such at any time as to call for stimulants. When required, only carefully-selected wines, such as old port or old dry sherry, or the best whiskey or brandy, should be used; and these are to be given in small doses and freely diluted, and their use is to be suspended as soon as may be deemed prudent. The prolonged use of stimulants in cases of habitual indigestion is rarely beneficial, and is not without danger of increasing the digestive trouble.

As the condition of the stomach and the power of taking food improve, it may be found that nothing more is needed than a continuance of the cod-liver oil or of the arsenic; but commonly it is better to substitute for them or to add to them small doses of iron, with quinine or strychnine. Indeed, it is sometimes found at an earlier stage of the case, when the anæmia and wasting are marked but the stomach is not very irritable, that very small doses of iron, in the form of the syrup of the iodide or the tincture of the chloride, or combined with vegetable bitters, as in the ferrated elixirs of gentian or cinchona, are well borne and digested, and are productive of distinct benefit.

Much of what has been said is applicable to the management of the habitual indigestion of older children. The same care is demanded as to their dress, bathing, rest and exercise, and diet. I am happy to believe that it is not as necessary to insist upon the primary and supreme importance of

these things, now that the claims of hygiene are widely recognized, as it was twenty years ago. But it is impossible too often or too strongly to call attention to them. The American climate, or climates (for there are many), have marked peculiarities, which, however, require only common-sense precautions to render them innocuous or even invigorating. Whenever a child thrives poorly, has chronic dyspepsia, and is pale and thin, a careful study of the clothing must be made. The underclothing throughout the year must be of wool, or of merino containing a large proportion of wool, the weight being of course adapted to the season. Slippers and low shoes must be eschewed, for the preservation of the warmth of the feet and legs is especially important.

Nothing is more valuable for children than to become accustomed to a daily sponge-bath with cool water, followed by brisk friction with a stout towel. This should begin not later than at the age of four years. The chill may at first be taken off by adding a little warm water, but it will soon become easy and pleasant to use it the year round of the temperature of the sleeping-room. Few children will become dyspeptic whose diet is reasonably wholesome and who chew their food properly, whose dress is suitable, and who are accustomed to the daily sponge-bath, with plenty of out-of-door exercise.

But when we are called to treat digestive disorders in children whose general health has suffered in consequence, it is, of course, necessary to use care in directing the proper kind and frequency of bathing. It may be necessary to restrict it at first to partial sponging with warm water, followed by general friction with a dry salted towel; but as soon as may be safe it is desirable to secure the tonic effect of the general cool sponging. In cases of more serious grade, where there is marked catarrh with great atony of the system, it is important to use daily inunction, with occasional sponge-baths with hot water and alcohol.

It is difficult to determine the proper amount of exercise for children, whether well or ailing. Their uncontrollable restlessness in health prompts them to as much as or more than is good for them. Not a few cases of dyspepsia result from indulgence in such constant activity as leaves too little nervous energy for vigorous digestion. Especially is this true of exercise soon after meals, which all observations show to retard this process. But in dyspepsia the child is often languid and indisposed to play or exercise; in which case it is essential to secure a proper amount of regular, gentle exercise, out of doors in fine weather and in-doors if inclement. Walking, riding a velocipede, horseback-riding, and light home gymnastics are specially recommended. The amount and kind of such exercise must be determined by the age, taste, and opportunities of the patient, and equally so by the influence upon the circulation, appetite, and sleep.

Abundant rest must be insisted upon. The child should retire early, and should always take a nap or a rest after the mid-day meal. In all cases where there is febrile action, and especially during the recurring spells

of increasing irritation with vomiting and diarrhœa, the child must be kept in bed until his usual condition is fully regained.

It is impossible to discuss fully the details of the diet, but some general observations may be made. The meals must be regular, must be eaten slowly, and every mouthful must be thoroughly masticated. In cases of severe catarrhal type (chronic gastric or gastro-intestinal catarrh) and during the acute exacerbations of irritation which occur in many atonic cases, it is necessary to restrict food rigidly, and for the most part to liquids, until the vomiting and extreme gastric sensitiveness are allayed ; after which a gradual return is to be made to the diet proper for the more chronic condition.

It is often necessary to allow considerable variety, as an insistence on monotony may breed disgust. But the variety should be only in the range allowed for successive days or weeks ; at no one meal should strict simplicity be departed from. Thus it is always necessary to write out a bill of fare, stating the hours, articles, and amounts of each meal. Otherwise, with the best intentions on the part of the mother or nurse, the whims or persuasion of the child will insure imprudence. As a rule, food should be taken four times daily : occasionally it will be found that more thorough digestion is secured by limiting the meals to three, and not rarely it is necessary for longer or shorter periods to give food in smaller amounts and at shorter intervals.

It is necessary to determine whether the digestion of starchy foods is specially defective. This is the most common type of indigestion in children : so that, as a rule, the dietary should include very few farinaceous articles. This is, however, only a general rule, and there are many exceptions to it. In proportion as there are evidences of fermentation the above rule is valid. Then there are cases, and they probably constitute a large majority, which can be rapidly benefited by a diet chiefly composed of soft-boiled eggs ; finely-minced lean meat ; raw oysters ; light broths ; a little green vegetable, such as spinach, cauliflower, stewed celery, asparagus-tips, or raw tomato ; and very little starchy food, and only in the form of soda-crackers, stale bread toasted, and rice ; and for beverages, hot water and hot milk, separate or mixed ; peptonized milk ; milk containing Mellin's food ; milk and lime-water, or rennet whey. Again, there are cases in which neither eggs nor milk can be taken, where the child wastes when restricted to meat and broths, and where it is found best to give at the morning and evening meals carefully-cooked (and, if necessary, peptonized) mush, and at dinner mealy potato either roasted or first boiled and then baked ; together with stale bread-and-butter, which is most wholesome when the bread is cut thin and the small amount of butter is gently rubbed into it, instead of being smeared over it as is usual. The soft part of oysters, raw or broiled, fish, boiled or broiled, beef, mutton, chicken, game, are all well received in most cases. There is, indeed, rarely any difficulty in providing a sufficient variety of simple meals, each consisting of very few articles, if only the subject receives that share of attention which its importance demands.

Finally, it must be observed that the condition of the bowels and of the urine must always be considered in ordering the diet. Scanty and heavily-charged urine indicates deficient absorption of liquid (usually from a scanty supply of water) or excess of nitrogenized food, one or both. It is easy to aid in overcoming constipation, which is often troublesome, by modifying the diet; and, on the other hand, the appearance of loose, fermenting, and undigested stools must be met promptly by restriction and change of food.

The indications for the administration of medicine should be carefully studied so as to grasp the fundamental defect which gives its type to the individual case. Above all things is it essential to avoid the use of too much medicine, and to avoid altogether any prescription which disgusts the palate or disagrees with the stomach. The cure of catarrhal inflammation if present, the arrest of fermentation, the relief of vomiting, of hyperæsthesia, or of neuralgia, the restoration of tone to the gastric walls, and the improvement of the quantity and quality of the gastric secretions,—such are the prominent indications presented in various combinations and degrees in different cases. It may happen that the arrest of fermentation by the simple prescription of proper diet is followed rapidly by the subsidence of the dependent catarrh and by the disappearance of all symptoms of dyspepsia. But more often, unfortunately, if catarrhal irritation has been excited, it requires special treatment, in addition to all that judicious diet can effect; and not rarely this element dominates the entire management of the case.

Counter-irritation to the epigastrium, by repeated applications of mustard plaster or of iodine of proper strength, is then of decided value.

Nitrate of silver deserves the first place among the remedies for this condition. Its action is not limited to the gastric surface; it seems to act also upon the intestinal mucous membrane. It should be given in small doses; and in solution or in pill, according to the age or special indications of the case: usually the solution is to be preferred in cases of pure gastric trouble, the pill when it is desired to reach the intestine. Doubt is often expressed as to any possible value attaching to the use of minute doses of nitrate of silver (gr.  $\frac{1}{12}$  to  $\frac{1}{4}$  in adults; gr.  $\frac{1}{48}$  to  $\frac{1}{12}$  in children) in gastro-intestinal or duodeno-hepatic catarrh. The chemical nature of the remedy is soon changed; the amount is too small to act directly upon the extensive surface affected. But the condition present is one of such morbid irritability that a minute amount of any indigestible food—nay, in some cases, even a teaspoonful of distilled water—will cause distress, nausea, and vomiting. And it is entirely credible that the repeated administration of minute doses of this peculiar sedative astringent may, by means of widely-disseminated nervous impressions, induce positive therapeutic effects far beyond the area of its direct action. The argument of clinical experience is, however, conclusive: though it is proper to repeat the statement that tact and judgment are required to obtain from this remedy all that it is capable of yielding in these delicate cases.

Creasote is deservedly used much in catarrhal types of dyspepsia at all

ages ; for it has a powerful antifermentative effect, in addition to its valuable local action. Thus, it controls vomiting, lessens flatulence, and acts favorably on the irritated mucous membrane. It is, however, somewhat difficult to administer to young children, on account of its peculiar and unpleasant odor and taste. The following formula may be used :

R Sodii bicarbonatis, ℥i;  
 Creasoti (beech-wood), gtt. iv ;  
 Pulv. acaciæ, q. s. ;  
 Glycerinæ, f℥ii ;  
 Ol. cinnamomi, gtt. iv ;  
 Aquæ puræ, q. s. ad f℥iii.  
 Ft. mist.

S.—A small teaspoonful in a little water soon after meals. For a child of six years.

Or the following :

R Creasoti (beech-wood), gtt. v ;  
 Bismuth. subnitratiss vel Sodii bicarbonatis, ℥i ;  
 Pepsin. (saccharated), ℥i.  
 M. et div. in chart no. xxx. (in small capsules).  
 S.—One after meals. For a child of six or seven years.

Carbolic acid is less unpleasant in odor and taste, but it is also less efficient for this purpose.

It is, of course, to be understood that what is now said is to be regarded as merely supplementary, as regards older children, to the remarks already made upon the treatment of habitual indigestion in infants.

Sulphurous acid is occasionally very valuable, even when vomiting is a prominent symptom ; but it is especially indicated where there is gastric atony with flatulence, with discharges of ill-smelling flatus :

R Acid. sulphurosi, gtt. xvi ;  
 Aquæ cinnamomi, f℥iv.

M. S.—From twenty to sixty drops in a dessertspoonful of water, according to effect, three or four times daily.

To this mixture it is often desirable to add one-fourth of a grain of strychnine ; or the following may be substituted :

R Quininæ sulph., gr. xxxii ;  
 Strychninæ, gr.  $\frac{1}{4}$  ;  
 Acidi nitromuriatici diluti, f℥i, vel Acidi phosphorici dil., f℥ii ;  
 Tinct. cardamomi comp., f℥ii ;  
 Aquæ puræ, q. s. ad f℥iv.  
 Ft. sol.

S.—From thirty to sixty drops in water after meals. For a child of from seven to ten years.

Pepsin, in some one of the highly-acceptable and reliable preparations now available, is an important aid in the treatment of many cases where the gastric secretions are deficient in quantity or quality, or in both.

When the stomach is settled, and reasonable amounts of food can be taken, the depravation of general health may suggest the use of cod-liver oil; and it is under such circumstances often taken willingly and with admirable results, pure, or in jelly, or in the form of an emulsion with lime (see page 15), with hypophosphites, or with wild-cherry bark:

℞ Ol. jec. aselli, f̄iss;   
 Pulv. acacie,   
 Sacchari, āā, q. s.;   
 Ext. pruni Virgin. fluid., f̄iii;   
 Aquæ puræ, q. s. ad f̄iv.   
 M. et ft. emuls. sec. art.

S.—From one to two teaspoonfuls after meals.

What was said on page 16 in regard to the use of arsenic and iron might be repeated here.

The use of stimulants in the chronic dyspepsias of older children should be directed with caution and hesitation. Very often in severe cases small amounts are required for short periods, on account of weakness and depression: their beneficial action is shown by improvement in appetite, in the appearance of the tongue, and in the circulation. In some cases of obstinate vomiting, spoonful doses of iced champagne, or of carbonic-acid-water containing a few drops of brandy, may succeed when many efforts have failed to arrest it. But there is much to be said against the prolonged use of stimulants, because of the loss of effect which follows, and of the risk of increased local irritation, and, in the case of older children, on account of the moral question involved. No such objection applies to preparations of malt, of which there are excellent ones in the market, and which often prove highly useful in these cases, by improving appetite, digestion, and nutrition.

Allusion must be made to the constipation which attends some cases and may be very troublesome. In each case the special cause of the constipation should be determined. If due to relaxation of the abdominal and intestinal muscles, owing to atony and flatulent distention, it may be relieved by friction, massage, and electricity, added to the cool sponge-bath. If owing to scanty intestinal secretions, modifications of diet, increased supply of water, the omission of all astringent remedies and the use of those which, like arsenic, the mineral acids, and nux vomica or strychnine, stimulate secretion and peristalsis, may suffice to overcome it. In either case the use of suppositories of gluten or glycerin or occasional enemas will give important aid if required. Laxatives, even of the mildest kinds, are to be avoided as far as possible. Most of them lessen appetite and impair digestion, and their action is apt to be followed by a reaction of greater torpidity. Occasionally, however, in spite of such measures, there is such severe constipation as to demand special medication. Small amounts of Carlsbad salt in hot water may act gently and kindly. Elixir of cascara may be given in carefully-graduated doses, or the solid extract in pill form

if the child be old enough to swallow a pill. If iron is indicated in the same case, some such combination may be used as—

R Pil. ferri carb., gr. xvi;  
 Ext. cascarae, gr. viii;  
 Ext. nucis vomicae, gr. ii.  
 M. et ft. mas. et div. in pil. xxxii.

S.—One, two, or three daily after meals as required. For a child of from seven to ten years.

Or

R Ferri sulph. exsiccata, gr. x;  
 Pil. aloes et myrrhae, gr. xvi;  
 Ext. taraxaci, gr. xvi.  
 M. et ft. mas. et div. in pil. xxxii.  
 S.—One twice or thrice daily after meals.

In all cases it is proper to begin cautiously with small doses, as the object is to produce not only a laxative but also a tonic action, so as to promote a regular habit of the bowels. Any overaction is to be deprecated; and, as already stated, laxatives are to be used only when it is impossible to get along without them.

#### CYCLICAL, FITFUL, OR RECURRENT VOMITING.

This condition, which is, we believe, by no means so rare as has been thought, has received comparatively little attention from medical writers in the past, and in consequence a large part of what we have to say comes from our own experience. Gee, of London,<sup>1</sup> has recorded no fewer than nine cases, all of which are particularly interesting.

**Definition.**—The state is one characterized by attacks of vomiting which recur after intervals of uncertain length, and between which the person is apparently in the enjoyment of perfect health. Generally the attack lasts but a few hours, but it may extend over three or four days, in which case the condition of the patient may approach that of profound exhaustion. The disorder occurs at all ages, and I have met with it at the various periods of childhood quite as frequently as in adults.

**Symptoms.**—Very commonly the attack is preceded, and it is nearly always accompanied, by pain in the upper part of the belly or around the navel, which in some cases is so severe as to require, for the time-being, more of the attention of the physician than the vomiting. The bowels are generally costive, but in a large number of cases they are loose or unaffected, and it is worthy of note that in every instance the stools are of a lighter color than normal. This condition may persist for some weeks, or even months, after the attack; and it appears that while the stools show such want of bile the tendency to recurrence of the attacks continues.

The vomiting differs in no way from that commonly seen in children, save in its periodicity of occurrence, the ejecta being made up of the gastric contents, and perhaps bile; towards the last it may be only watery, or

<sup>1</sup> St. Bartholomew's Hospital Reports, 1882, vol. xviii. p. 1.



it may contain traces of mucus. The violence of the gastric disturbance differs in different cases. In some the attacks consist in a refusal on the part of the stomach to receive any liquids or solids; in others the retching and straining keep on whether food is taken or not; while in still others it happens that the gastric irritability shows its presence at certain periods of the day only, food being retained at other times. In cases where the attacks are prolonged for several days, and the vomiting is severe, the amount of depression resulting may seem highly alarming and dangerous. After the attack has passed away the walls of the abdomen are often tender and ache, from the efforts at vomiting.

In some of the cases fever of an irregular type may accompany the gastric disturbances, while in others no variation of temperature occurs. In one of Gee's cases, where the vomiting was replaced by retching without the expulsion of the contents of the stomach, the attacks generally lasted but for a few minutes, were accompanied by no pain, but by marked pallor of the face, and the temperature of the body at certain times rose as high as 105° F. without any obvious cause.

**Etiology.**—It has seemed to me that the essential element in the production of recurrent vomiting is a state of nervous depression and irritation affecting especially the centres and fibres supplying and controlling the stomach and liver. I have known this condition to be established almost immediately by a nervous shock, or by excessive fatigue, though more usually it is brought on by the prolonged action of depressing causes. When once it is established, it requires comparatively slight influences to excite a spell. The symptoms indicate the existence of hepatic torpor in most cases, and not rarely a slight degree of gastric catarrh is associated. Not improbably it is the development of some irritating ptomaine which causes the explosion; or else it is a lowering of the already depressed innervation which violently disturbs the equilibrium of the gastro-hepatic functions. Indigestible food is not so common a cause as might be expected, unless articles difficult of assimilation are taken at about the time that an attack is likely to come on. In many cases exposure to cold seems to be the provoking factor, while in other cases the closest observation may fail to discover anything which can be called a cause. The truth is that the underlying tendency above alluded to, however acquired, varies greatly in its intensity in different cases, so that the causes needed to call it into action vary greatly in degree, and vary also in kind, according to the different susceptibilities of the individuals affected.

The periodicity of the attacks is difficult of explanation. In some instances the spells recur at such irregular intervals as scarcely to merit the name of cyclical: they show only the existence of a continuous tendency which is aroused from time to time by the recurrence of the exciting causes. In other cases greater regularity in recurrence is noted, suggesting that the susceptibility of the nervous system is developed periodically under the operation of some rhythmic influence. It may be that these attacks of a more strictly cyclical character are sometimes the evidence of a gastric *petit mal*;

and even when this cannot be established, there are interesting and important analogies suggested. Rarely malarial poisoning may be at the bottom of the disease, and under such circumstances the attacks are apt to be peculiarly regular in their recurrence.

Occasionally the development of the condition may clearly depend upon a preceding acute disease. Thus, I have seen it follow typhoid fever; and in one of Gee's cases no other cause could be assigned than an attack of measles occurring twelve months previously. In this case the attacks of vomiting were very frequent, recurring as often as once a week.

**Treatment.**—It is evident that one of the first things to be done is to prevent exposure to the exciting cause in each instance, and so to regulate the diet and the functions of the digestive canal as to prevent the production of catarrhal states, or the development of the poisonous matters which are formed by the fermentation of food in the stomach. The vomiting, if severe, should be treated by doses of calomel and bismuth, or, if such medication fails, bromide of potassium, or chloral, or small doses of laudanum, should be administered in weak solution by the rectum. As the vomiting goes on, there is frequently a tendency to collapse; and it is in this stage that brandy in a concentrated form, and preferably hot, seems to act with particularly good results, producing a stimulation of the flagging nervous power and allaying the tendency to vomit. Here, again, medication may be by the bowel if the stomach refuses to receive any liquid, the brandy or whiskey being warmed thoroughly, and in this case diluted sufficiently to avoid rectal irritation and tenesmus. For the abdominal pain, which is, as we have stated, often severe, external applications only should be employed, such as very weak mustard plasters containing just enough of the mustard to bring a blush to the skin over the epigastrium. The hot brandy often brings relief in this state also, and the well-known spice plaster, made up of allspice, cloves, cinnamon, and black pepper, is often a remarkably good application. Opium should be avoided as far as possible, as, although its use brings temporary relief, it may be followed by so much systemic depression as to do more harm than good. Not only is this true, but, by the locking up of the undigested food in the bowel, fermentation is increased and true gastric and intestinal catarrh may result. Not rarely, however, after the stomach and duodenum have been emptied by repeated acts of vomiting, and when the bowels have been moved spontaneously or by the aid of an enema, and when the retching and straining continue frequent and severe, it is necessary to administer small doses of opium by the rectum. I have had some highly interesting results from the use of small doses of antipyrin administered in cyclical vomiting as soon as the first symptoms of an attack present themselves. These results encourage a further use of this remedy in such cases.

If collapse is threatened, hot applications and cardiac stimulants are strongly indicated, and should be pushed until some reaction sets in.

Where the exhaustion is due to the inability of the child to retain food

rather than to excessive retching and abdominal effort, nourishment should be given by the rectum in the form of predigested milk, such as is now so readily prepared by means of the pancreatic preparations.

#### GASTRALGIA.

**Synonymes.**—French, *Gastralgie*, *Gastrodynie*, *Cardialgie*; German, *Magenschmerz*, *Magenkrampf*; Latin, *Erethismus ventriculi*, *Hyperæsthesia ventriculi*; English, *Spasm of the stomach*, *Nervous cardialgia*, *Gastrodynia*.

This affection is rare in children; yet, as it occurs, it merits attention.

**Definition.**—An affection characterized by sudden, sharp, lancinating pain in the stomach, coming on without premonition, as a general rule, and lasting for a few moments or, in rare cases, a number of hours. It is distinctly a neurosis, and, while the sensation experienced by the patient may be that of gastric spasm, it is probable that no real contraction of muscular fibre occurs.

There is no organic lesion of the stomach associated with the trouble, nor is there any marked functional disturbance. It is to be clearly separated from the pain accompanying either one of these states, and is in reality a violent form of neuralgia affecting nerves so closely associated with vitality as to cause more distress and fear than similar affections elsewhere. It is true that in some forms of dyspepsia the amount of epigastric distress or actual pain may be so great as to form the most prominent symptom in the case; but it should be clearly understood that even such cases cannot with accuracy be styled *gastralgia*.

**History.**—In the past there has been much confusion regarding this disease, and in consequence various terms have been used to indicate it which have in reality no appropriateness and in many instances are so out of place as to express affections of other organs than the stomach. Thus, even at the present time the terms *cardialgia*, *gastrodynia*, *spasm of the stomach*, *stomachic colic*, and *neuralgia of the stomach* are all used to signify one and the same disease. It is evident that the first of these is an absolute misnomer, while several others are expressive of quite another state than that which exists. The only terms which may correctly be used as synonymous are *gastrodynia* and *neuralgia of the stomach*.

As already stated, *gastralgia* is comparatively rare in children, seldom being seen below fifteen years of age, and in this matter it agrees with our experience in respect to other forms of neuralgia.

**Etiology.**—The causes which induce *gastralgia* are various. Sex is a strong predisposing cause, and, in consequence, girls are much more commonly affected than boys. This is particularly noticeable at the approach of puberty. Temperament is even more potent than sex, since neurotic children suffer more frequently than those of a phlegmatic type. Again, that great and potent cause of neuralgia, improper nutrition, with its invariable concomitants, *anæmia* and *debility*, also is found to be here present

as an exciting cause. Depressed vitality, nervous strain, excessive excitement, privations, exposure to cold, and sudden fright and grief are all causes. The ingestion of exceedingly cold liquids or solids and the sudden suppression of old and chronic cutaneous discharges have been long recognized as factors in the production of gastralgia; while the migration of parasites from the intestine into the stomach is probably a more common factor than is generally assumed.

The question as to how frequently the ingestion of indigestible foods is a cause is an exceedingly difficult one to answer, owing to the frequency with which pain follows such acts even under ordinary circumstances; but in the vast majority of cases true gastralgia is not so produced.

It is, however, evident that when the neuralgic tendency exists the irritation caused by the presence of indigestible food may readily excite a paroxysm. These are the ordinary causes in children, but attacks of pain altogether resembling gastralgia may be caused by organic disease in other parts. Thus, incipient caries of the dorsal vertebræ may, by irritating certain nerve-filaments, cause such spells of pain.

Certain cases are but the manifestation of malarial poisoning, and Niemeyer has pointed out that attacks of gastralgia are sometimes present in lieu of a chill. Rheumatism may perhaps be a cause, but, unless the hereditary tendency is most striking, it seldom can be looked upon as such in children.

The habit, so prevalent in the lower classes, of permitting the use of coffee and tea by very young children is undoubtedly an occasional cause of this rare disease, as it often is in adults. In boys who begin the use of tobacco before puberty this drug has a powerful predisposing influence, and Stillé believes that this is the most common cause of gastralgia in adult males in the United States.

**Pathology.**—Numerous views have been brought forward to explain this interesting disorder. It is supposed that the nerves involved are the sensory fibres of the pneumogastric and the solar plexus, and in all probability it is the former which are most commonly at fault. The nerve-supply of the stomach is very closely connected with that of the general abdominal cavity, for the right vagal branches are distributed to the posterior surface of the stomach, after which they join the left side of the celiac plexus and the splenic plexus. The left vagal branches are distributed over the anterior surface of the stomach and to the lesser curvature. They unite with the branches of the right vagus and with the sympathetic, and some filaments pass through the lesser omentum to the left hepatic plexus. For these reasons it is readily seen that very widely separated causes of irritation may produce the trouble, and also how readily the abdominal contents, as well as those of the thorax, might share in a paroxysm of pain. It has been already pointed out that this disease is to be separated from the pain accompanying gastric troubles, organic and functional.

**Symptoms.**—The symptoms of this disease are easily recognized. The

child, without apparent cause, is of a sudden seized with a pang which in its severity is to be compared to that of angina pectoris, the face becomes pinched and livid, and the belly-walls are found to be retracted and knotty, or relaxed from the depression of excessive pain. At the onset of the paroxysm a sharp cry is given, and the hands may be pressed against the epigastrium while the body is bent over in agony. The pulse is slow and full, owing to the involvement of the filaments of the pneumogastric, or in other cases is equally rapid and running, but is always hard. The sensation on applying the finger to the pulse in the wrist is one of high arterial tension in the early stages of the trouble, and remains so through the attack, unless the paroxysm lasts an unusually long time, when the exhaustion of prolonged suffering may relax the spasm of the blood-vessels as it is apt to relax the entire body.

If the attack is one of a fleeting character, a single dart of excruciating agony may cause the child to give one loud scream and to fall to the ground in the acme of its pain. The skin may be covered with sweat at the height of the paroxysm.

It is of importance to remember that children very frequently find difficulty in referring to the seat of pain, be the pain where it may, so that heart-pains are often referred to the abdomen, and abdominal pain to the chest. In some cases the pain has its onset only when the stomach becomes empty, or in still others vomiting may occur.

Sometimes the attacks are periodical. In these cases there is a sensation of fulness in the stomach even amounting to a feeling of bursting, and epigastric pressure may or may not be accompanied by relief. In the cases where the sensation of fulness is felt, the application of pressure is often disagreeable or even painful. Pulsation in the epigastrium is sometimes seen, and in rare instances the pain extends to other parts of the body, so that the chest and even the arms may suffer in the general nervous storm. If any hysterical tendencies exist, there are often shortness of breath and irregularity of the heart's action preceding the attack, associated with those general symptoms so commonly seen in hysteria. Here, as in all forms of irregular hysterical manifestations, the differential points as to the cause of the trouble may be sought after without finding a ready explanation.

**Diagnosis.**—The diagnosis of gastralgia from other painful affections of the stomach is of great importance.

Gastric cancer, which in children is of extreme rarity, can scarcely be mistaken for it. The pain is more apt to follow the ingestion of food, while in gastralgia it rather occurs shortly before the time of meals; vomiting is common; palpation detects a sense of induration or a distinct tumor, and cachexia soon makes its appearance and can be distinguished readily from the anæmia or even the chlorosis which may attend gastralgia.

Again, the acute, sudden, fleeting form of gastralgia may resemble a *petit mal*, somewhat, when it is epigastric. The separation of these two diseases is vitally important for prognosis and treatment, and is by no means

readily accomplished, save as the case progresses. Although *petit mal* is not so rare as gastralgia in children, this particular form of pain in the belly as a symptom of the state of minor epilepsy is quite as rare, if not more so; indeed, we have known of only one such case, which afterwards passed into major epilepsy and died. In this instance the child would suddenly cease its play, give a scream of pain, and return to its toys.

While the immediate diagnosis between the two affections may be difficult, the past and the subsequent history of the case separate the facts into lines which point more and more divergingly to epilepsy or gastralgia.

The disease most closely resembled by gastralgia is, after all, gastric ulcer, but the latter is so rare in children, and is so generally associated with other signs when it does occur, that it can be excluded in making a diagnosis. There are usually also progressive wasting, an habitual rejection of food, a more frequent onset of pain after food, and more evidence of functional gastric disturbance in gastric ulcer than in gastralgia. The pain in ulcer is also more circumscribed, and the matters vomited may contain more or less blood.

From intercostal neuralgia it is to be separated by its location in the epigastrium; by the fact that the pain appears less superficial; by the absence, except in rare and unusually severe cases, of pain in the chest increased by respiration; and by the absence of painful nerve-points or hyperæsthesia along the course of a superficial nerve, as may be found in pleurödynia.

Gastralgia and hepatic colic may occur with symptoms nearly allied, but the icterus, the prolongation of the pain for a certain length of time, the tenderness over the hypochondrium, and the history of previous attacks of biliary colic will establish the diagnosis. The fact that one of the vagal branches is distributed to the hepatic plexus may make the differentiation, so far as the area of the pain is concerned, impossible.

From the pain of functional gastric disorders gastralgia is divided by the suddenness of its onset, by the lack of eructations and vomiting, and by the absence of a coated tongue and of tumidity and tenderness of the belly.

Cardiac disease may directly or indirectly produce symptoms of gastralgia. Either the pain may be referred by the patient to the abdomen, as we have said, or it may in reality exist there by reflex action or disordered circulation.

**Treatment.**—The treatment of gastralgia may be divided into two parts,—that directed to the relief of the attack when it is present, and that directed to the prevention of other attacks. During the acute stage hot applications and drinks, aromatic and locally stimulating warm infusions, a few drops of chloroform, or brandy, or whiskey, hot and concentrated, or a few drops of laudanum, may be used. Counter-irritation often does good, and in some cases, particularly if a suspicion of an hysterical element exists, a vigorous revulsive may act with surprising power. Emesis and purgation

are sometimes indicated, since in the early attacks the cause of the pain may be suspected to be the presence of indigestible food.

The treatment required in the intervals between the attacks must vary with the cause and with the general condition of health. A careful search must be made for the real cause of the trouble, and when found it must be removed or palliated by appropriate measures.

The diet should be carefully regulated, and all the hygienic details of the child's life be critically studied and directed. The avoidance of improper food, the abandonment of tea, coffee, or tobacco, the prescription of proper dress, exercise, or change of residence, may be followed by marked improvement in general health and by a cessation of the attacks of gastralgia.

In regard to remedies, it may be premised that all depressing drugs must be avoided, as well as all purgatives which would weaken the digestion. Any marked disturbance of digestion should be corrected; and this may require the use of pepsin, or of some tonic remedies such as suggested in the article on dyspepsia. The chief reliance is, however, to be placed upon the administration of arsenic and iron immediately after meals, in proper form and doses. Thus, we may direct—

R Liq. potassæ arsenitis, f̄ʒi;  
Vini ferri amari, q. s. ad f̄ʒiv.  
Misce.

S.—From thirty to sixty minims in water after meals three times daily, for a child of six years.

Or

R Tinct. ferri chloridi, f̄ʒi;  
Acidi muriatici diluti,  
Liq. arsenici chloridi, aa, f̄ʒss.  
Misce.

S.—From four to eight drops in water after meals three times daily.

Occasionally even better results are secured by the use of cod-liver oil in emulsion with hypophosphites. It is well, in cases where the tendency to pain is decided, to combine with the above the use of a powder of bismuth subnitrate and saccharated pepsin, given about an hour or an hour and a half after meals. Constipation, should it exist, may be overcome by diet, massage, enemas, or by suppositories of gluten or glycerin and soap. If the bismuth favors its continuance too decidedly, small doses of cyanide of potassium, dilute hydrocyanic acid, or chloroform may be substituted at the same hours. In cases where a highly neurotic state exists, it may be necessary to alternate with the bromides or preparations of valerian.

# DISEASES OF THE STOMACH.

By HOBART AMORY HARE, M.D.

---

WHILE it is true that during the period of childhood the stomach is the organ most frequently at fault, careful thought will show very clearly that in nearly every instance the symptoms surround a gastric condition of perverted functional activity, and not one of essential morbid change. For this reason our knowledge of gastric disease occurring before puberty cannot be aided by post-mortem research in those cases which go on to a fatal termination. In the adult, on the contrary, trouble with the stomach is commonly dependent upon actual morbid changes, which in some cases are characteristic of certain periods of life, and in others may be regarded as the results of the prolonged continuation of functional disorder. In the child functional disturbance is generally so mild that the youthful tissues repair any injuries, or else is so severe that death ensues before any structural alterations can occur. Further than this, the natural course of events prevents, to a large extent, any abuse of the stomach sufficient in severity to bring about in children gastric ulcer and similar states, and even if the same causes are at work their manifestations are so positive that their existence is recognized, or forced upon the parents, by the violence of the systemic symptoms,—symptoms which in the adult are hidden by a greater degree of vital resistance and stability, or else are purposely and persistently ignored, until such advanced changes take place that ineradicable structural alterations are developed.

For these reasons, it has been thought well to separate the consideration of gastric disease into two parts, the first of which, by Dr. Pepper, deals with those disturbances of function which are more commonly seen in children and which arise from errors in diet and other similar causes, while the second part deals with gastric disorders accompanied by distinct organic change, readily demonstrated by a macroscopic or a microscopic examination, and equally characteristic in all cases.

The functional disorders are more frequently seen and more readily cured, while the diseases associated with distinct lesions not only present for treatment many of the signs seen in the previous class, but also force the physician to the care of altered tissue. For these reasons the subject of *diseases* of the stomach lacks the importance in children which it possesses in adults.



No better example of this can be found than the subject of gastric ulcer. Careful search through the literature of medicine shows so few cases of true ulcer of the stomach in children as to make it evident that this very common ailment in adults is a curiosity before puberty, and also shows that only one or two of the cases on record present signs of ulcer distinctly comparable to the lesion as found in the adult. Without entering into a useless discussion concerning the etiology of such a state, logical deduction and the reports of the instances where the disease has been seen in childhood show that the causes at this period of life are inevitably different in character and mode of action. The majority of instances of gastric ulcer in children have been found complicating and due to general tuberculosis, and have been multiple and distributed widely, not only over the gastric walls, but also far into the duodenum and even up into the œsophagus. In other words, the gastric affection is only a small part of the trouble present, and exists not as a well-defined, localized lesion as seen in the adult, but as a fractional part of a wide systemic involvement of almost every part of the body. Gastric ulcer in the adult is a local malady, while gastric ulcer in the child is in most cases only a part of a constitutional disease. As a natural consequence, we find that the treatment of ulcer of the stomach in the child is separated from that of the disease in the adult, for, if the trouble be constitutional rather than local, therapeutic measures must be addressed quite as much to the improvement of the general system as to the local lesion resulting therefrom.

By far the most important fact to be remembered in the diagnosis and treatment of gastric disease in childhood is that symptoms pointing to other regions than the stomach may be present in such force as to cover completely the true source of the malady. In the following pages I have pointed out the fact that children commonly refer pain and discomfort to portions of the body which we know, by their anatomical position, cannot be involved even sympathetically with the stomach. Not only is this the case, but, in addition, it is to be remembered that disease of other parts may be produced by such troubles. A child, after slight fatigue and no known change of diet, is taken ill with what seems to be a severe coryza: the nasal mucous membrane streams with mucus, and the eyes are somewhat injected and tearful. After a few hours a loose cough is developed which is frequently repeated and harassing, and pain in the throat is complained of. Restlessness at night becomes a pressing symptom, and careful examination by the hand shows epigastric tenderness. The tongue is coated unevenly and is flabby. Careful questioning develops the fact that the child had been restless at night for a week before any other signs appeared, that the appetite has been getting progressively worse, and that the bowels have been confined. Pain in the stomach from flatus has also been present.

Here are all the signs, at the early stage, of what is commonly called "a cold," but which are produced reflexly by the condition of the stomach. In some cases the "cold" may be "caught" owing to exposure when the system is depressed; but, be this as it may, measures directed to the air-

passages are useless until the gastric condition is set right. Expectorants, tonics, and all else fail if the stomach is neglected.

The use of such drugs very commonly seems to aggravate the symptoms. Quinine may be given to relieve a state of listlessness supposably due to debility, and only serve to irritate the gastric mucous membrane the more. Nearly all tonics in the early stages of gastric inflammation do likewise, for at this time the inflammation causes an excessive activity of the cells. Only in the later stages are tonics to be given to do what their name implies,—add tone to the part.

In all cases of disease in children the physician should carefully examine into the condition of the stomach before the administration of drugs is begun.

#### GASTRITIS.

**Synonymes.**—Inflammation of the stomach, Gastric catarrh, Inflammation dyspepsia ; French, Embarras gastrique ; German, Magenentzündung ; Latin, Inflammatio ventriculi.

**Definition.**—As gastritis of an idiopathic type rarely, if ever, in children involves more than the mucous membrane of the stomach, seldom dipping down into the submucous and muscular coats, I have preferred to divide the consideration of this subject into two separate parts, under the headings of acute gastric catarrh and chronic gastric catarrh, descriptions of which here follow.

There may be, however, a deep-seated gastritis produced by the ingestion of irritant matters of various kinds, and perhaps no better opportunity for its consideration can be found than at this place.

In all cases where acids and alkalis of a strong and irritant character are swallowed, intense general inflammation naturally occurs ; and this is true in very young children if any of the irritant spices, such as pepper, for example, are taken in excess. Sometimes a similar state is induced by the accidental swallowing of hot liquids, which, after injuring the cesophagus, injure the stomach. In these cases the inflammation is distinctly of a traumatic origin and can be clearly separated from the idiopathic forms, which have no such history. Blows upon the epigastrium may cause gastritis.

The symptoms are intense epigastric pains, vomiting, and sometimes a raised or lowered bodily temperature. The belly, at first scaphoid, rapidly becomes tumefied, and if the inflammation is very severe the case goes on into general involvement of the peritoneum and intestines by extension of the inflammation. After death the mucous membrane is intensely engorged, reddened, and angry-looking. The lymph-glands of the submucous coat are raised above the surface and hardened. Mucus in large amount, perhaps tinged with blood, is seen spread over the inflamed surface in patches. All the coats are infiltrated with lymph, so that the walls of the organ are much thickened. The muscular layers are found to be swollen, and evi-

dences of their paralysis by inflammation may be recognized by the retention of food in the viscus.

The *treatment* is to be directed entirely to the prevention of the spread of the inflammation and to the relief of that already developed. If the patient is seen soon after the onset of the trouble, the stomach is to be emptied of all irritant substances by means of vomiting induced by large draughts of warm water, or by the use of the stomach-pump. Mucilaginous drinks are to be given freely, and albuminous matters seem especially useful. Oils and similar protective liquids aid in preventing further damage. Opium, to allay pain and the local and systemic irritation, is invaluable. It should always be given in liquid form, and the deodorized tincture is the best in this respect, owing to its freedom from narcotine. Paregoric contains too little opium, and is irritating because of its volatile oil. If the stomach will bear no drugs, they should be given by the rectum. If evidences of collapse appear, hot applications, atropine, or belladonna should be exhibited. It is important that the heat should be applied over the epigastrium and chest, and a flaxseed poultice is the best method of doing this.

The after-treatment must be directed to the support of the patient, the avoidance of all exposure for a long period of time, and the use of foods which are entirely devoid of irritant matters and easily digested.

DIPHThERITIC GASTRITIS (Teriche<sup>1</sup>) is a lesion so completely secondary as to be worthy of only passing mention. As its name implies, it is caused simply by an extension of the false membrane down the pharynx and the œsophagus until the stomach is reached. It is exceedingly rare. Niemeyer<sup>2</sup> states that in infants the catarrhal inflammation sometimes goes on into the croupous.

#### ACUTE GASTRIC CATARRH.

**Synonymes.**—Status gastricus, Gastricismus, Gastrosis, Disordered stomach.

**Definition.**—A disease characterized by vomiting preceded by listlessness, anorexia, and nausea. In the older child the refusal of food may be absolute, but in the infant the breast may at first be taken eagerly, the milk being almost immediately ejected. It is, particularly in its milder forms, a very common ailment in children. Pathologically it consists in a hyperæmic condition of the gastric mucous membrane, and, as a consequence of this, there are increased secretion from the mucous glands and a diminished flow of gastric juice, according to the belief of many well-known authors, although, so far as we know, there is no reason for believing this condition to be present other than that digestion is impaired. The lesions found, if death occurs, may be so slight as to be out of all proportion to the intensity of the digestive disturbance during life. Occasionally the hyperæmia of the living stomach is lost in the anæmia of the organ in death. Des-

<sup>1</sup> Ziemssen's Cyclopædia, vol. vii.

<sup>2</sup> Practical Medicine, vol. i. p. 503.

croizilles<sup>1</sup> asserts that the mucous glands are enlarged so as to form many inequalities over the membrane, and in this he would appear to be in accord with Widerhofer<sup>2</sup> and Kundrat, who believe that there must be some abnormal change in these bodies.

**Etiology.**—The causes of this affection are exceedingly varied, but the chief of them depend upon badly-prepared or indigestible food, or, if the food is not really indigestible, upon some condition of the digestive function which renders even the ordinary liquids obnoxious to the gastric mucous membrane. Very commonly do we see, in bottle-fed infants especially, attacks of indigestion and mild or severe gastric catarrh produced in some inexplicable manner, even though the food has been prepared with the greatest care and has agreed with the stomach for weeks or months. Eustace Smith asserts that a cold is a very frequent cause of the disease, producing a hyperæmia of the gastric mucous membrane rather than of the mucus membrane of the pharynx. In his experience exposure to cold is a more frequent factor than anything else, and there can be no doubt that repeated exposures followed by acute gastric catarrh are powerful predisposing factors in the development of subsequent attacks. Improper clothing, by exposing the child's abdomen and epigastrium to draughts of air or to damp and cool air, renders the patient peculiarly susceptible. We are inclined to think, however, that exposure is in America a much less frequent cause than bad feeding, and that poor or improperly-prepared food is the chief factor.

Breast-fed infants rarely suffer from it, and, when they do, change in the maternal system, or cold, is the common cause. Dentition is undoubtedly a common exciting cause, as is also general vital depression and enfeeblement, particularly in the lower classes, who are surrounded by poor hygienic conditions.

There are other causes of a more constitutional character than those just mentioned, which may act as factors. In rickets there is nearly always a marked susceptibility to catarrh, and, as might be expected, scrofulosis is not an infrequent agency. In some cases there seems to be a strong predisposition to gastric catarrh which may appear to be hereditary.

Irritant substances swallowed by mistake or given by the physician may produce this condition, notably the use of ipecac in full dose, or the employment of the various so-called peripheral emetics possessing local influence, as tartar emetic and sulphate of copper, or mustard-water.

In children who are old enough to take "table-food," as it is generally called, there are several causes of acute gastric catarrh which are frequently overlooked. There can be no doubt that the ingestion of hot coffee and tea is a common cause, the heat doing as much damage as the drugs themselves. Not only is this statement based on general clinical evidence, but

---

<sup>1</sup> Manuel de Pathologie et Clinique des Enfants, Paris, 1883.

<sup>2</sup> Gerhardt, Handbuch der Kinderkrankheiten, Bd. iv., Tübingen, 1878.

it is supported by experimental facts. Thus, Decker,<sup>1</sup> of Würzburg, has found it possible to produce even gastric ulcer in dogs by feeding them by means of a stomach-tube on food heated to 120° F. (49° C.); and the well-known fact that adults, particularly females, who drink large amounts of hot tea are subject to a similar disorder (gastric ulcer) is additional evidence. Alcoholic beverages are also productive of gastric catarrh, and, while the majority of children do not indulge in such liquids, the infantile members of most German families emulate their parents in the consumption of beer to an astonishing degree.

Secondarily, acute gastric catarrh may occur in the course of the fevers, as in pneumonia, typhoid fever, and erysipelas; and, lastly, tuberculosis, syphilis, and renal disorders may predispose to, or produce, such an inflammation. Once set up, the disease aids itself by the mucus secreted, which undergoes fermentation and consequently irritates the stomach still more.

Anæmia is productive of gastric catarrh in a twofold manner,—primarily by lowering the resistive tone of the gastric mucous membrane, secondarily by the lack of digestive power which is sure to accompany it. We see these facts illustrated almost daily in adults, and it is fair to assume that in both the full-grown individual and the child the digestive juices are under such conditions much impaired as to both quantity and quality. For this reason small and delicate children are particularly apt to suffer from this very malady. Aside from these points of clinical evidence, we are possessed of direct experimental proof of our deductions, for Manassein<sup>2</sup> has shown that after artificial anæmia is caused in dogs the normal relation between the acid and the pepsin of the gastric juice is destroyed.

It is disorder of the digestive juices which brings on gastric catarrh, since by this means food remains too long in the stomach and ferments. As the digestive juices have been found to be altered in animals and men suffering from fever, it would appear probable that the gastric catarrhs of febrile states are thus produced. In those cases where stomatitis exists it is exceedingly common for the patches to go down into the stomach, producing gastric catarrh and intestinal disturbances.

**Pathological Anatomy.**—We have already described with sufficient clearness the state of the stomach after death. The lining membrane of the stomach is often covered completely by a layer of tough tenacious mucus, and the hyperæmia is frequently hidden by this means.

**Symptoms.**—There are two distinct types of this disease, so far as disturbances of the bodily temperature are concerned. In one type the temperature remains about normal, in the other there is often pyrexia; but we think that the former is the more common of the two unless the irritation is extreme or the trouble depends on strumous or tubercular taint.

<sup>1</sup> British Medical Journal, 1887.

<sup>2</sup> Virchow's Archiv, lv. 451; also Centralbl. f. d. Med. Wiss., 1871, p. 853.

The first is shorter in its duration than the second, and is, as one would naturally suppose, far less serious. The extremities are often cold and perhaps moist.

Early in the disorder there may be anorexia, and listlessness amounting almost to relaxation. The eye loses its lustre, and drowsiness, which does not deepen into sleep, asserts itself. Nausea now comes on, and, if the child is old enough, headache of a more or less severe type is complained of. Vomiting soon replaces the nausea, and at first consists of the contents of the stomach, which are sour and ill-smelling. If milk has been taken, it is always curdled. The vomiting does not cease with the expulsion of the food in the stomach, but continues until mucus and perhaps bile make their appearance. If the vomiting is a late symptom the mucus may coat the food in the form in which it was swallowed, acting in such a way that the digestive fluids cannot attack it. Retching now supervenes, and may be painful from its severity as well as exhausting, and at the same time, or commonly much earlier in the attack, the tongue becomes coated and whitened, save at the tip and edges, where it is red and glazed. The papillæ of the tongue are prominent and project above the coating, dotting the organ with red spots.

This condition may persist for a varying length of time, but eventually ends by slow return to normal digestive and general power, or more rarely the return to health is rapid. Commonly other areas of mucous membrane suffer, so that coryza or mucous purging may be present.

If the attacks are frequent they speedily influence the general health.

There is sometimes epigastric tenderness, but this is rarely marked.

There are other evidences of disorder of the gastric mucous membrane than the localized stomach-symptoms and the prostration which have been spoken of. The surrounding organs become disturbed, particularly the small intestine. As a consequence the case may become one of gastro-enteritis, or more rarely icterus and constipation ensue. The breath is, from the first, foul and heavy, while the secretion of saliva may be abnormal in quantity, sometimes dribbling from the mouth. The urine is often scanty. If the systemic disturbance is great, herpetic blisters appear about the mouth, in children who are subject to such symptoms.

In some cases the symptoms become far more severe than any we have yet mentioned, and, according to Seibert,<sup>1</sup> may closely resemble those of meningitis, of malarial affections, and of typhus fever.

Sometimes gastric catarrh and dyspepsia produce curious nervous disturbances. Convulsive seizures as the result of gastric and intestinal disorders are too well known to require much more than a passing reference. The convulsion may be tetanic or clonic, or even both states may be present. Most commonly it is first tonic, then clonic. The child is left much exhausted when the attack has passed by, and often falls into a state of collapse

---

<sup>1</sup> Jahrbuch f. Kinderheilkunde, xxvi., II. 3 u. 4, p. 348.

and unconsciousness, or else is seen by the physician staring wildly about, with anxiety strongly depicted on its face.

There is a much more rare set of nervous disorders, however, set up frequently by these states. Localized or diffuse clonic movements sometimes appear. Dizziness may be present, and high fever or an abnormally low temperature may mark the aberrant functions of the nervous system. Aphasia has been recorded as present in several cases. Thus, Henoch<sup>1</sup> mentions an instance of a girl of two years in whom total aphasia came on in an hour, so that pinching could call forth no word from the child but the sound "Au!" The aphasia passed away an hour later, speech returning perfectly after the vomiting of some cherries.

Another instance is that of a boy who had overloaded his stomach with food, and in consequence was seized in the night with severe colic and a liquid, ill-smelling diarrhoea. In the morning, after a deep sleep, he also could only make the sound "Au!" when he was pinched. By the following day he was well, but was at first bewildered and mentally disturbed. A third case was virtually identical with that just given. Siegmund records<sup>2</sup> a case occurring in a nine-year-old girl, in whom vomiting came on spontaneously, and in whom aphasia passed off as soon as the stomach was relieved.

The organs of respiration also suffer from similar reflex disturbances. In children who are prone to spasmodic croup a potent cause of the affection is indigestion, and both adults and children often have dyspeptic or gastric asthma.

Fraenkel<sup>3</sup> records a case of hemiplegia brought on by gastric irritation in a four-year-old girl who had eaten large amounts of "table-food." Half an hour after eating she lost the power of movement and sensation on the right side. Even the right conjunctiva was anæsthetic. The next day recovery occurred. Sensation returned first, and shortly afterwards the power of movement was restored.

**Diagnosis.**—It is comparatively easy in the first or early attacks to separate this state from many others of disordered alimentary function, and if the history as to the cause is clear the difficulty is much decreased. In some instances, however, the vomiting, with its retching, may resemble that of meningeal tuberculosis, from which it is to be separated by the history, appearance, and prolongation of the attack, as well as by the mental and nervous symptoms. Again, typhoid fever of a mild type may be represented if the attack is prolonged, and the very indefiniteness of the acute paroxysms may cause them to be mistaken for the forerunners of some acute contagious malady.

**Prognosis.**—The prognosis of acute gastric catarrh is invariably favorable unless the predisposing state endangers life in itself or the attack passes

---

<sup>1</sup> Berliner Klinische Wochenschrift, 1883, xx. 334.

<sup>2</sup> Discussion of Henoch's paper in the Medical Society (loc. cit.).

<sup>3</sup> Schmidt's Jahrbücher, 1883, 2, ii. 261.

on to a more serious lesion. It is very common for relapses to occur during convalescence, and even after recovery seems complete.

**Treatment.**—By far the most important point in the treatment of acute gastric catarrh is the regulation of the diet. This may be divided into two parts,—first, the regulation of the food during convalescence or during the attack, and second, the character of the food to be used during the interval following one attack and preceding the next. Total abstinence in the acute stages of the attack, and absolute bodily and mental quietude, are advisable. There are several reasons for this. In the first place, the juices of the stomach are in an abnormal state and unfit to receive more food. Secondly, the mucous membrane of the stomach is already hyperæmic from the inflammation, and, as the normal viscus takes on a physiological hyperæmia on the ingestion of food, we should add to the injection of the blood-vessels did we allow more nourishment to enter the viscus. Last of all, the excess of the mucus and lactic and butyric acids present renders any new food impure before it can be assimilated, and so prolongs the trouble. As the attack passes off, small amounts of food may be given, readily digestible and not likely to become easily decomposed or rendered acrid by the mucus in the stomach. Milk with a large percentage of lime-water is to be used, since the alkali not only prevents a too firm coagulation, but also decreases the secretion and action of the mucus. The thirst may be excessive, although anorexia is complete, and small pieces of ice may be administered for its relief. Commonly it will be found that the patient rapidly improves up to a certain point, then stops or relapses. This is due to the accumulation of mucus, which undergoes fermentation, and, if marked evidences of the presence of this secretion are given, a mild and gently-acting emetic may be employed to dislodge the fermenting mass. Sodium bicarbonate with compound infusion or compound tincture of gentian may be used in convalescence, and small sips of effervescing draughts are useful. If constipation exists and vomiting forbids the use of the ordinary purgatives, a Scidlitz powder divided into fourths or fifths and taken in this way every fifteen minutes or half-hour will settle the stomach, move the bowels, and often carry away mucus.

If there is much epigastric distress, a spice poultice is often of service.

Sweets and starches are to be rigidly denied the patient. If anæmia exists, iron may be used; but this is rarely needed.

The abdomen should be carefully protected with flannel, and draughts and unsanitary surroundings avoided.

The use of pepsin and of hydrochloric acid is to be much more thoroughly attended to than has heretofore been the custom. As a rule, we are apt to forget that pepsin acts largely by catalysis, and that it is not secreted as pepsin, but as pepsinogen, a substance which is changed into pepsin in the presence of an acid. For this reason hydrochloric acid should be freely employed, and pepsin given in large or small quantity according as there is reason to believe this ferment to be in normal or abnormal amount.



Common salt (sodium chloride) is virtually identical in its ultimate influence with hydrochloric acid, and should be always used, in moderation, with the food.

#### STENOSIS OF THE PYLORUS.

**Synonymes.**—Hypertrophic pyloric stenosis (Lebert),<sup>1</sup> Fibroid degeneration of the pylorus (Habershon).<sup>2</sup>

**Definition.**—A condition of the pyloric opening of the stomach characterized by a thickening of one or more of the coats of the viscus at this point. In some instances in adults it has been thought to be due to cicatrices formed by old ulcers, or to the ingestion of irritants, but in children it is never due to this cause, in all probability, owing to the extreme rarity of ulcer and cancer and of the ingestion of an irritant poison.

It must be understood that such factors produce stenosis of another type than that of which I speak, which is an idiopathic thickening or hypertrophy, independent of other diseased states, or existing as a congenital defect.

**Clinical History.**—Be the causes of stenosis what they may, it is impossible to differentiate one variety from another during life by the direct symptoms produced, although the condition of the patient may, by reason of other signs, point to the character of the obstruction, as, for example, the cachexia of cancer or the history of hæmatemesis in gastric ulcer. If the stricture is complete, so as to prevent the flow of the gastric contents into the duodenum, death very rapidly ensues, being preceded by a train of symptoms characteristic of obstruction of the alimentary canal, and consisting in violent vomiting, tympanites of an epigastric type, and generally a comparatively receding abdomen, owing to the prevention of the entrance into it of food. If the occlusion is congenital and the opening is closed from the first, this latter symptom is particularly noticeable, and under these circumstances the case passes through a more or less rapid course to death, a result which is reached quickly or otherwise according to the constitution of the child. Collapse always comes on as the case progresses.

Pyloric stenosis in children, even of a congenital type, is exceedingly rare, and partial narrowing of the pylorus is seldom seen. It has been a favorite theory that pyloric stenosis as found in the adult is congenital in origin; but, while the adult pylorus has been frequently found narrowed, the instances of this condition reported as having been found in children have been much fewer in number, proving that the state is not so largely congenital as had been thought. Very recently, however, Hirschsprung<sup>3</sup> has reported two interesting cases of this character. In one of these an apparently healthy infant, well grown and developed, died on the thirtieth

<sup>1</sup> Die Krankheiten des Magens, Tübingen, 1878.

<sup>2</sup> Diseases of the Abdomen, London, 1862.

<sup>3</sup> Jahrbuch f. Kinderheilkunde, Bd. xxviii. H. 1.

day of life in collapse, having previously suffered with frequent vomiting and small and infrequent stools. The vomited matters never contained bile. The child was entirely breast-fed. The autopsy showed the stomach to be distended, its walls thickened, and the pyloric portion firm and enlarged to the extent of an inch. The opening would allow only a small sound to pass through. The muscular layer was deformed, and the mucous membrane was hypertrophied. In the second case tuberculosis was the cause of death at six months of age, and the autopsy revealed a somewhat dilated stomach, both the muscular and the mucous layer being thicker and harder than normal. This change extended over the entire stomach, but affected the pylorus particularly, the pyloric opening being very narrow.

There was a previous history of prolonged vomiting, but it may have been due to the tuberculosis. As Hirschsprung points out, the child might, so far as the gastric lesion was concerned, have reached adult life.

Neale<sup>1</sup> records a case of imperforate pylorus in which the stomach soon after birth rejected all food, and the child died of inanition and exhaustion. After death the pyloric opening was found congenitally closed.

Goldenhorn and Kolatschewski<sup>2</sup> record a case of pyloric stenosis producing great gastric dilatation and dependent upon a polypoid tumor of the mucous membrane of the pylorus.

Wünsche, Andral, Förster, and Bull have also recorded such cases.

**Pathological Anatomy.**—So few cases of this disease in children are recorded that our pathological knowledge must be derived largely from the condition in adults. In such persons it is generally found, as in the cases of Hirschsprung, that more than one coat is involved in the change, although sometimes only a single coat is at fault.

Cirrhosis of the stomach has been confused with this lesion, and except for the confinement of the disease to this particular area the changes are very closely allied to each other. The submucous coat frequently has an increase in its connective-tissue elements, and the muscular coat is truly hypertrophied, partly, perhaps, as the result of the trophic change, and partly by the endeavor on the part of this coat to force the gastric contents through the narrowed orifice of the pylorus.

**Diagnosis.**—The constant distention of the stomach, the progressive failure in nutrition, and the repeated and uncontrollable vomiting, along with the absence of stools or their exceedingly small quantity, are sufficient to cause grave suspicion of such a state, or of obstruction in the duodenum or a little lower down. In some cases the enlarged pylorus may be felt through the walls of the belly, but the distention of the stomach generally forbids this. Ulcer, and cancer producing stenosis, may be excluded by reason of their rarity: the disease itself, however, is of very infrequent occurrence.

---

<sup>1</sup> Lancet, London, June 7, 1884.

<sup>2</sup> Berliner Klinische Wochenschrift, 1888, xxv. 51.

**Prognosis.**—Total occlusion is necessarily fatal. In partial occlusion the possibility of saving life is very slight.

**Treatment.**—To allay the vomiting, small doses of opium may be used, and, if the stricture be not complete, food should be given which is ready for assimilation, and in very small amount. Rectal enemata may be employed, and stimulants may be freely used. The question of operation for the relief of pyloric stenosis is hardly to be thought of in very young children, for, aside from the shock of so radical a measure, the possibility of any gain by interference is exceedingly slight. If congenital stenosis is present, as is, of course, most likely to be the case under the circumstances named, there is no telling what other abnormal states complicate it, and the prognosis is correspondingly obscure.

If, however, in any case the diagnosis is clearly of obstruction of the pylorus, operative procedures are to be attempted, with the distinct understanding that the procedure is but the chance of a forlorn hope.

#### DILATATION OF THE STOMACH.

**Synonymes.**—Gastrextasia, Gastric ectasy, Gastric dilatation, Dilatatio ventriculi.

**Definition.**—A condition of the stomach in which there is marked laxity or dilatation of its walls, generally uniform in its distribution, but often greatest at the cardiac end. It is to be most carefully separated from the condition, so commonly seen in children, which depends for its presence on imperfect digestion both gastric and intestinal, accompanied by enlargement of the entire belly and with no absolute increase in the capacity of the abdominal viscera. Very frequently gastric distention due to the accumulation of food or gases is mistaken for the state in which an absolute increase in the diameters and capacity of the stomach is present. Cases of this character of gastric distention are often called cases of functional dilatation.<sup>1</sup>

**History.**—Gastric dilatation has been recognized as a common and distinct morbid state for very many years, in both adults and children, but the latter class of cases have been thought to be rare.<sup>2</sup> Though the literature of the subject in respect to children is far more limited than is that devoted to adults, yet we already have a large number of cases recorded, and several authors by their communications have placed before us a very complete study of the disease. Chief among these may be mentioned Thiebaut,<sup>3</sup> Comby,<sup>4</sup> and Moncorvo.<sup>5</sup> Comby alone gives the history, in a very full manner, of no fewer than forty-three cases occurring in children as young as two and one-half months of age, and upward. In addition to the authors

<sup>1</sup> Centralblatt für Kinderheilkunde, October 1, 1887.

<sup>2</sup> Welch, *Pepper's System of Practical Medicine*, vol. ii.

<sup>3</sup> Thèse de Nancy, 1882.

<sup>4</sup> De la Dilatation de l'Estomac chez les Enfants, *Arch. Gén. de Méd.*, 1884, ii., tom. xiv. p. 148.

<sup>5</sup> De Dilatação do Estomago nas Creanças e su Tratamento, Rio de Janeiro, 1883.

already quoted we have Widerhofer,<sup>1</sup> who records a case occurring in a twelve-year-old girl, in whom the dilatation was great but the cause thereof ill defined. Lafage<sup>2</sup> reports two cases, one at ten years and another at sixteen years; while Demme,<sup>3</sup> of Bern, records an enormous dilatation of the stomach at six and a half years, as does also Pauli.<sup>4</sup> In this instance the supposed cause was congenital stenosis.

Clifford Allbutt,<sup>5</sup> after stating that gastric dilatation is much more common in children than is generally thought, details two typical cases, one in a boy of three or four years, the other in a boy of ten years. In our own case, represented in the accompanying photo-plate, the age of the child was eighteen months.

**Etiology.**—This disease in the child has for its factors several conditions, both local and systemic. In the first place, stenosis of the pylorus may, by its partial obstruction to the flow of food, dam back a large amount of ingesta, which, as it increases in bulk, requires more space and gradually distends the gastric walls to such an extent as to produce partial palsy of their muscular coats at the very time when increase in muscular power is needed to overcome the obstruction. At the same time the delay in the evacuation of the viscus causes the development of a certain quantity of gas. As the result of fermentative changes, the chemical reaction of the mass is no longer normal, while the mucous membrane, becoming irritated, may add to the abnormality of the contents of the stomach by secreting a mucous coating which covers it and the semi-digested food.

How frequently stenosis is actually present as a factor is difficult to determine. As we have already pointed out, in the section on this disease, it is not a common lesion in childhood, even if it be congenital, and there are unfortunately not only very few cases of this character reported which have been confirmed by autopsy, but still fewer which have been found in conjunction with dilatation on the post-mortem table. There is no doubt of the ability of pyloric stenosis to produce dilatation of the stomach: the only question is as to the frequency of its own occurrence.

Another local cause is inherent atony or weakness of the gastric walls, a condition very common in rachitis of an advanced type. Under these circumstances there is lacking that force which is necessary for the carrying out of the two physiological functions of the organ,—namely, the rolling of the food backward and forward for its thorough infiltration by the gastric juice, and its ultimate expulsion into the duodenum. Rickets is so closely associated with bad feeding that there can be no doubt that the muscular walls of the stomach are influenced not only by the general systemic state known as rachitis, but also by the direct involvement of the walls themselves.

---

<sup>1</sup> Gerhardt's Handbuch d. Kinderkrankheiten, Bd. iv. Abth. 2.

<sup>2</sup> Thèse de Paris, 1881.

<sup>3</sup> Berliner Klinische Wochenschrift, 1883, No. 1.

<sup>4</sup> De Ventriculi Dilatatione, Frankfurt, 1839.

<sup>5</sup> Proceedings of the Medical Society of London, vol. xi., 1887 and 1888.

If the food be poor in quality the hunger of the child often leads it to over-distend the stomach time after time in order to obtain sufficient nourishment, and this over-distention and malnutrition soon increase the capacity of the organ. Indeed, it is stated that the muscular fibres of the fundus of the stomach in artificially-fed children are very commonly weak, so that from the earliest period of life there may be a tendency to dilatation.

While the stenotic state of the pylorus produces a purely mechanical expansion of the gastric walls, atony of the stomach may be considered as resulting in an imperfectly-carried-out physiological act, the consequences of which are in the end virtually identical with those of stenosis. Not only is this true, but the gastric disorders of digestion and fermentation come on rapidly and with great severity, since the digestive function of the stomach is quite as atonic as that of the muscular layers.

Tuberculosis of this organ may be a cause, owing to the weakness thus produced, and, as gastric tuberculosis is by no means rare, this possibility is not to be overlooked. Rilliet and Barthez found the stomach involved in twenty-one out of forty-six cases of tuberculosis which they examined.

Secondary dilatation from the adynamia of asthenic states and fevers may be present in children as well as in adults, and marasmus, chlorosis, cachexia, and anæmia may so result. Hygienic surroundings which produce all these states are, therefore, a cause. Moncorvo<sup>1</sup> even states that malaria may be a cause.

Ulcers of a tubercular or ordinary nature situated in the stomach may so result, but their occurrence is excessively rare in children.

Chronic gastric catarrh may also be a cause of dilatation, by reason of the delay in digestion and the consequent closure of the pyloric opening until the act is completed. Welch asserts that chronic gastric catarrh may produce a parietic state of the muscular layers, just as is seen in laryngitis or corresponding lesions. In adults atrophy of the muscles has been noted as a cause, but it has not been recorded as present in childhood, and Edinger<sup>2</sup> states that amyloid changes may occur with such a result.

No evidence exists of atrophy and paresis of the stomach resulting from peripheral or centric nervous lesions and followed by dilatation, although Machon<sup>3</sup> and Thiebaut<sup>4</sup> assert that cerebral diseases may produce it. Machon also asserts that the child's stomach shows in every instance a relatively defective development of the fundus and a greater diameter than normal of the œsophageal orifice; while the muscular coats and peptic glands are poorly developed, the mucous glands are well formed; in other words, all the conditions tending to ectasy are present. Thiebaut also asserts that cardiac disease and repeated vomiting may produce gastric ectasy, and that adhesions outside of the pylorus may have a similar effect.

<sup>1</sup> Revue mensuelle des Maladies de l'Enfant, July, 1885.

<sup>2</sup> Deutsches Archiv f. Klin. Med., Bd. xxix.

<sup>3</sup> Centralblatt f. Kinderheilkunde, October 1, 1887.

<sup>4</sup> Thèse de Nancy, 1881.

Kundrat and Widerhofer believe that overfeeding is a cause of considerable importance, and they assert that dilatation is not uncommon in children as a result of this.

**Pathological Anatomy.**—We have virtually no details as to the exact size of dilated stomachs in children. That enormous enlargements do occur, as in adults, is, of course, true, but further than this all remarks are based on theory alone. There is a certain change, however, which, as it occurs in adults, should be recorded as a possibility in childhood,—namely, muscular hypertrophy along with dilatation; and this formation is particularly apt to occur where stenosis produces dilatation. On the other hand, the wall may be atrophied. No degenerative changes are found in the muscular walls, as a rule. As the normal stomach varies so widely in size and shape, care should be exercised at the autopsy that a false diagnosis be not made.

**Symptoms.**—Aside from the general symptoms of disordered digestion, commonly considered under the title of dyspepsia, there are symptoms which are particularly marked in gastrectasia. In the early stages there is great thirst and loss of appetite, with persistent coated tongue and emaciation. Absolute repugnance to food, amounting at last to total refusal, finally comes on, but if the child be breast-fed or bottle-fed it will often take milk in order to relieve the thirst. Vomiting is always a prominent symptom, the matters vomited being often greenish and extremely fetid, and nearly always profuse in amount. Examination of the ejecta will generally show food swallowed days before, owing to the imperfect digestive action of the stomach, and this very inability of the stomach to act on the food generally gives, for a long period of time, a sense of weight and fulness often amounting to pain, and complained of bitterly if the child be old enough to define the sensation. There is tenderness over the epigastrium on pressure, and the displacement produced by the palpation often brings on either acid or yeasty eructations or even the vomiting already named. Nausea preceding the vomiting is by no means common, there being simply a gush of foul liquids from the mouth. After such an occurrence the vomiting fails to recur for from twenty-four to forty-eight hours,—*i.e.*, until the viscus becomes overladen once more. The gases which are given off on eructation are exceedingly acrid, nauseous, and bitter. Sometimes they are offensive, but more rarely odorless. No analysis of these gases has, so far as we are aware, been made in children, but in adults they have been found inflammable. They consist of oxygen, nitrogen, hydrogen, and carbonic acid. Sometimes sulphuretted hydrogen is present in large quantity.<sup>1</sup> The reaction of the vomit is almost always acid, lactic and butyric being the acids most commonly found. Fibres or masses of semi-digested and semi-decomposed food can be seen by the naked eye or

<sup>1</sup> Ewald, in Reichert und Du-Bois Reymond's Archiv for 1874, p. 222, gives an analysis of one of Frerichs's adult cases, in which the amount of carbonic acid was 17.40, hydrogen 21.52, marsh gas 2.71, olefant gas traces.



CASE SHOWING AREA OF FLATNESS ON PERCUSSION WHEN THE STOMACH IS DISTENDED.





under the microscope, and sarcinae and many forms of bacteria swarm in the mass. Particular search should be made for the yeast-fungus, *Torula cerevisiæ*, the presence of which is a certain evidence of active fermentation. The condition of the bowels is almost invariably that of advanced constipation, and this state is largely dependent upon the small amount of food which escapes into the duodenum, the general debility and lack of exercise, and the pressure upon the transverse and the ascending colon.

The complications of gastric ectasy in children may be exceedingly various, owing to the notorious irritability of the nervous system. Convulsions of a tetanic or more commonly of an epileptiform character may come on during the periods of over-distention or immediately after an attack of vomiting. Sleep is often disturbed and restless, and the wakefulness may even amount to total insomnia. Emaciation becomes extreme, but the wasting is gradual rather than rapid, owing to the fact that some parts of the ingested matters are assimilated during the period of gastric quiescence. Anæmia is generally far advanced. The limbs are wasted, the legs particularly showing, by comparison with the swollen epigastrium, their lack of flesh. The skin hangs loosely everywhere save over the affected area, where it is tightened almost to the point of bursting. The abdominal surface is often covered by engorged and multitudinous veins, which on pressure show themselves to be carrying the blood-stream from below upward. Borborygmus is sometimes startlingly loud and prolonged, and seems to last for minutes at a time, rarely accompanied by pain. Constipation is always present, but if laxatives or purges are given they bring on a gush of partially-digested food and liquid from the rectal opening which is remarkable because of its volume. It is often blackish and always horribly offensive, flowing from the diaper over the child and its clothing. Commonly, if the child be young enough to take only a milk diet, large cheesy morsels are seen in the stools. Peristaltic waves can be seen as they pass along the wall of the stomach itself, on the epigastric surface, which may be made more marked by the application externally of heat or cold, or by draughts of cold water. In respect to adults, however, Francon<sup>1</sup> asserts, as does also Thomson, that this sign is present only when pyloric stenosis exists. The liver and other abdominal organs are rarely either swollen or decreased in size, except indirectly by the general malnutrition.

As an indirect, reflex symptom of this disorder, Blache<sup>2</sup> speaks of night-terrors, and asserts that dyspnoea and cardiac palpitations may be developed in such cases.

**Diagnosis.**—Inspection shows a distended and tense belly, highly tympanitic in the upper portion on percussion, or, if the ingesta be in large amount, dulness may be developed. The belly is so distended at the upper part as to have been called “frog-belly” by the Germans and the French.

---

<sup>1</sup> Lyon Médical, 1887.

<sup>2</sup> Revue mensuelle des Maladies de l'Enfant, February, 1886.

Penzoldt has proposed the pouring of so much water into the stomach as to distend it completely, and then by means of percussion to define its boundaries and thereby obtain some idea of its dimensions; but, as Pacanowski<sup>1</sup> has pointed out, such a procedure would be dangerous if ulcer be present. This scarcely holds as an objection in children, owing to the rarity of ulcer, but it is a means of diagnosis which children in America and England can hardly be subjected to, and is certainly harmful to some degree. Lente has proposed the introduction of a sound which may be twisted around while one hand follows it through the abdominal walls; but this method is, to say the least, heroic.

Again, it has been proposed by Frerichs and Moneorvo to make a diagnosis by what the latter calls "plessimetric gastro-resonance," which consists in the ingestion of several grains of bicarbonate of sodium and four grains of tartaric acid followed by two tumblerfuls of water. This is a method which I believe to be absolutely unjustifiable.

By far the most important point to be decided, after that of the existence of dilatation, is how far the lower edge of the stomach has been carried downward; for it is worthy of remark that the upper surface rarely alters its position very greatly, although it may be pressed up against the diaphragm, rendering any attempt to percuss its upper outline almost impossible, owing to the liver and ribs, or even the lung, being in the way. In some cases the diaphragm is so displaced as to become useless as a respiratory muscle. Oftentimes the lower border of such a stomach may pass as low as the navel, or even to the pubes. Obrastzów<sup>2</sup> states, as a differential point between the gastric outline in adults and in children, that in the latter under the age of fifteen years the lower border seldom reaches to the navel, while it may do so in the adult. The position of the stomach in the young child is so entirely different from that of the adult that the same outline of resonance or dullness is not to be looked for as it would be in a grown person. In the child the stomach is scarcely more than a dilatation in the course of the alimentary canal, and as such the pyloric end of the stomach is much lower than the cardiac extremity. Further than this, the fundus is virtually absent in children. There are other points to be remembered of an anatomico-physi-

FIG. 1.

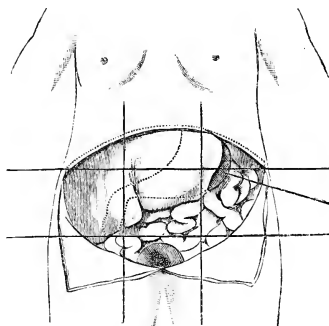

Diagram showing the position of the stomach and liver in a child of about two and a half months. Dotted line shows outline of stomach, which is partly covered by the liver.

<sup>1</sup> Deutsches Archiv f. Klin. Med., 1887.

<sup>2</sup> *Ibid.*, 1888, xliiii., 4 and 5, p. 417.

ological character which apply to both the adult and the child and are frequently overlooked,—points which make the area of resonance when the stomach contains no food at variance with the area when it does contain solids and gives dulness on percussion.

When the stomach is empty the great curvature is directed downward and the lesser upward; but when the organ is full it rotates on an axis running horizontally through the pylorus and cardia, so that the great curvature appears to be directed to the front and the lesser backward. Although this movement is largely absent in very young children, it increases very rapidly as growth goes on, and probably is always established at the end of the second or third year.

Auscultation may, on shaking, give a well-developed succussion-sound, while gurgling is exceedingly common. As, however, succussion is commonly heard in nearly all stomachs, much importance is not to be attached to this sign.

Severe dilatation of the stomach in childhood separates itself so clearly from almost every other state that a differentiation is not needed. Moderate dilatation, which is more common and therefore more important of recognition, is far more difficult of diagnosis, and yet can be separated from other states if care is exercised. From enlargement of the liver it is to be separated by the difference in the area involved on inspection, and by the all-important fact that in liver-enlargement the percussion-note is dull or flat, whereas in dilatation the sound elicited on percussion is generally tympanitic, unless the stomach is filled with food. The great exception to this rule is found when no vomiting has occurred for some days, when, by reason of the accumulation of liquid in the stomach, a flat note may be obtained. While the percussion-note may not be always completely diagnostic, it may be made more so by changing the position of the body, as in pleurisy. Palpation is also of great value, the hard, smooth surface of an enlarged liver being distinctly characteristic, while the more yielding but tense sensation given to the fingers and hand in dilated stomach can by no possibility be taken for that imparted by a solid organ. Splenic enlargements may be separated from dilated stomach in the same manner. Again, the area of dulness from enlargement of these two organs is constant, while that of dilatation varies with the quantity of food and liquid, and can always be increased by the ingestion of large amounts of water. Disease of the pancreas occurs so

FIG. 2.

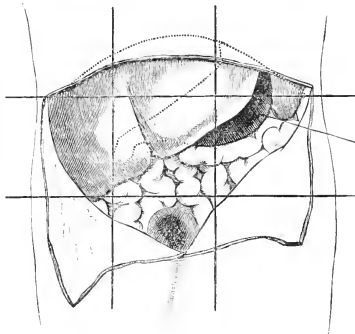

Diagram showing position of stomach in a child of four months. Dotted line shows outline of the viscus, which is partly covered by the liver.

rarely that it cannot be regarded as a probable condition, and there is never produced under these circumstances the same train of symptoms in both states. Dilatation of the colon is not to be forgotten, since it gives many similar signs.

Dropsy and ascites may, of course, be mistaken for dilatation of the stomach, but the presence of greater bulging in the lower third of the abdomen than in the epigastrium, and the fact that dropsical effusions may be found elsewhere, will aid in the differentiation. Succussion is not marked in ascites, and there is commonly in this state some evidence of heart-disease, of renal disease, or of tumor pressing on the large venous trunks.

Catarrhs of the intestinal mucous membrane associated with fermentative changes and distentions by flatulence produce deformity in the suprapubic rather than in the epigastric area, and are accompanied by other symptoms too well marked to be overlooked, such as mucous diarrhoea, colic, and perhaps lientery. The latter condition, too, is not so chronic, nor so slow in its onset.

As an aid to diagnosis the question of the capacity of a child's stomach at different ages is an interesting one, since it may be possible to gain by lavage or emesis some idea of the capacity of the individual stomach before us, and thus discover whether there is any difference from the normal. Benke<sup>1</sup> states that the capacity of the new-born child's stomach is from thirty-five to forty-three cubic centimetres, at fourteen days it is from one hundred and fifty-three to one hundred and sixty cubic centimetres, and at two years it reaches seven hundred and forty cubic centimetres. These results are not in accord with those of Townsend given by Rotch in the first volume of this *Cyclopædia*: he found the stomach of a child of five days to hold only twenty-five cubic centimetres. Rotch states that the capacity at twelve months is one hundred and twenty cubic centimetres.

According to the studies of Frolowsky,<sup>2</sup> the activity of growth in gastric capacity can be represented by the ratio of one for the first week to two and a half for the fourth week and three and one-fifth for the eighth week. It is only three and one-third for the twelfth week, three and four-sevenths for the sixteenth week, and three and three-fifths for the twentieth week. In this connection the diagrams Fig. 1, page 291, Fig. 3, page 296, and Fig. 4, page 297, in Dr. Rotch's article in the first volume of this work, are of interest.

**Prognosis.**—The prognosis is always unfavorable, but it is more favorable in children than in adults, as the distention may cease and the child grow up to its stomach. The great danger in children lies in inanition and exhaustion.

**Treatment.**—The treatment of dilatation of the stomach may be divided into two varieties,—the first consisting of the methods of cure which are directed against the state of the gastric walls themselves; the

<sup>1</sup> Ueber die Capacität des Magens Neugeborenen: see *Deutsche Med. Wochenschrift*, vi., 32, p. 433, also 33, p. 448.

<sup>2</sup> Inaugural Dissertation, St. Petersburg, 1876.

second, of those methods in which abnormal changes in the food and the gastric contents and secretions are combated, thereby allowing reparative changes to take place. As has already been said, dilatation of the stomach may be dependent upon either some constitutional or some local cause. If the cause be rickets, it is evident that the malnutrition of the bony system and of the system in general is to be improved, and that remedies devoted to this object are to be given,—cod-liver oil by inunctions, or, if the digestive apparatus will bear it, by the stomach. Lacto-phosphate of lime, phosphate of sodium, or iron, often in the form of the syrup of the iodide, should be used if any signs of struma are present. Good foods, possessing large amounts of salts, yet easy of digestion, are, under these circumstances, particularly desirable, and by far the larger part of the treatment should be directed to the dietetics of the case. Of this I shall speak farther on.

There are several means to be employed for the relief of gastric dilatation other than those which can be called medical, so far as drugs are concerned.

These consist, first, in efforts to evacuate the stomach and to cleanse it; secondly, in attempts by these and other means to prevent its distention by the gases which arise or by the accumulation of ingesta which takes place; thirdly, in the regulation of the diet so as to avoid causes which have a tendency to increase the disorder.

Dilatation of the stomach is so difficult to cure that very satisfactory results are not to be looked forward to, but nevertheless the nutrition and the general state of health are to be carefully considered.

Taking up *seriatim* the non-medicinal means which we have named, we come at once to the consideration of lavage, a method which has been resorted to with most thorough trial on the continent of Europe. Originally proposed by Epotius in 1863, it has been most widely employed in children by Epstein,<sup>1</sup> who in one article alone records its employment in two hundred and eighty-six cases of gastric disease in infancy, the patients being less than one year of age.

Epstein employs a No. 8 or a No. 10 Nélaton catheter for the tube, and warm water holding in solution a little benzoate of magnesium, the latter being resorted to chiefly when fermentation- and decomposition-products are present. If none of these conditions are present, ordinary water will usually suffice. The liquid employed should always be warmed. Others—as, for example, Lorez<sup>2</sup>—use the ordinary English catheter, of the size known as No. 11 or No. 12. The question as to the variety of tube to be employed is a vital one, since a poorly-devised apparatus not only gives no relief, but disgusts both the patient and the physician with the technique of the method. The tube should be more like a hollow bougie than like a catheter, in order that its calibre may be great enough to carry off some of

<sup>1</sup> Virchow's Jahresbericht, June, 1883 (abstract); original article in Arch. für Kinderheilkunde, Bd. iv. S. 325.

<sup>2</sup> Arch. de Patol. Infantil, July, 1888.

the semi-solid matters present. If this rule is not carried out, two evil results follow. In the first place, the tube and its apertures rapidly, or even at once, become clogged; secondly, the liquid is drained away, leaving behind a mass which is semi-solid, to be sure, and less bulky, but which is nevertheless the quintessence of the nastiness of fermentation, and quite as qualified to leaven any fresh food on its entrance as the liquid would be.

The holes in the gastric end of the tube should therefore be large enough to take in fairly large masses. In some cases the ordinary siphon may be used, but where there is any solid food or resistance, suction by means of a stomach-pump is necessary. The tube should be, for a child, twenty-four or thirty inches in length. The methods by which lavage is employed, further than those we have named, are as follows. The catheter or tube should be passed backward against the roof of the mouth, so that by following the curve of the hard and soft palates it is directed into the pharynx and cesophagus, and then by gentle pressure forced on down into the stomach. The irritability of the pharynx rapidly disappears, and it is surprising how quickly the patient may become accustomed to the operation and submit to it without any feeling of discomfort. After the tube has reached the stomach, a small funnel is to be fitted in its external end, which is then held above the head of the patient while water prepared in the way we have mentioned is poured into it until the stomach is filled, when the funnel end is lowered and the stomach is emptied by siphonage.

The stomach-pump has one very serious disadvantage, which is present with even more force in the child than in the adult,—namely, the danger of injury to the coats of the organ. This apparatus is also more costly and cumbersome, and for children the siphon is powerful enough in its action to take away all excuse for the use of the more complicated apparatus unless the contents of the stomach are in bulk.

It is particularly necessary in children, on account of the lack of intelligent aid and their liability to gulp, that every care should be taken that the tube does not slip entirely out or reach into the stomach, and for the prevention of this danger a string should be attached to the external end of the tube before it is introduced, and the tube should always be at least thirty inches in length.

The treatment of dilatation to be considered after lavage is dietetic. There can be no doubt that one of the chief reasons for the emaciation which comes on is the failure on the part of the stomach to digest and assimilate nourishment. In addition to this, the intestine is really the place for absorption of food to take place, and the delay in the stomach virtually makes the chyme unfit for the function of the small intestine.

The foods to be given are, of course, to be in the highest degree capable of ready assimilation, and should be confined, especially in severe cases, to the materials which we can readily predigest by the employment of the digestive ferments now so largely sold. Carefully-skimmed milk is valuable, aside from its inherent usefulness, in that it lacks the fats which can be

utilized only in the intestines and which simply break down and decompose if kept in the stomach. Oyster broth, carefully freed from any oily matters in cooking, and thoroughly pancreatized, is to be given. These questions are, however, more thoroughly discussed in the articles on feeding, which may be found in the first volume of this work.

Rectal alimentation to some degree is always useful, particularly in older children, and Ewald, of Berlin, suggests the following nutrient enema: Beat up two eggs with a tablespoonful of cold water; to this add a little starch, boiled in half a cupful of a twenty-per-cent. solution of grape-sugar and a wineglassful of red wine. The solution is to be well mixed at a temperature not high enough to coagulate the albumen, and injected as high up into the bowel as possible. For a child this mixture should be somewhat less in quantity than that given above for the adult, particularly as to the wine.

An exceedingly important part of the dietetic treatment of gastric dilatation consists in the constant bearing in mind of the fact that the tendency of food is to accumulate, and the avoidance of the pernicious habit of adding solids or liquids to the quantity of ingesta still remaining from a previous meal. If the child is old enough, all the remains of previous feedings should be removed by lavage before anything more is given, since otherwise the sweet food is at once contaminated by the liquids which it meets in the stomach.

The medicinal treatment of gastric ectasy is, unfortunately, very limited so far as the stomach itself is concerned, and, indeed, we doubt whether any direct medication can ever be of much value unless in the form of disinfectant substances such as we have spoken of in studying lavage, and these only prevent decomposition of the food and do not effect a cure.

#### GASTRIC ULCER.

**Definition.**—An exceedingly rare affection in childhood, characterized by epigastric tenderness and the vomiting of blood, the gastric discomfort generally being increased by the ingestion of food. The essential lesion is an ulcer of varying size and depth situated somewhere on the gastric mucous membrane.

So rare is the affection that very few, in fact only one or two, of the text-books on the diseases of children refer to it, and, as the literature is so meagre, we are forced to give far less information than we should desire.

According to Descroizilles,<sup>1</sup> the symptoms are as follows. At an early stage of the disorder an anorexia develops itself, which is steadily progressive, so that it may become complete. Vomiting may come on, or in some instances nausea is the only symptom. Eructations and pain are also frequently present, and the ingestion of food, as in the adult, is generally followed by an exacerbation of the suffering.

In some cases, however, the symptoms are very aberrant, and the diag-

---

<sup>1</sup> Pathologie et Clinique infantile, Paris, 1883.

nosis is almost impossible in consequence. Indeed, Descroizilles asserts that under these circumstances there is nothing typical of the condition present.

Should perforation of a blood-vessel occur, there result great circulatory disturbance, violent pain, and abundant vomiting and purging of blood, followed more or less rapidly by collapse.

**Etiology.**—Most commonly gastric ulcer in childhood comes on as a complication of some of the more frequent diseases, such as pneumonia, tuberculosis, and purpura hæmorrhagica. Strumous states also predispose to its formation, and all conditions of asthenia are prime factors in its production. Typhoid fever has, for this reason, been stated to be a cause.

**Pathology and Morbid Anatomy.**—According to Descroizilles, the ulcer is rarely larger than a bean, but may be as large as a twenty-five-cent piece. While it is generally of a tuberculous nature, it is not so invariably, but may be due, as has been already stated, to other causes than systemic tuberculosis. The edges of the ulcer are irregular, and reddish or even yellow in color, and the depth of the lesion may be so slight as simply to invade the superficial mucous membrane, or it may dip down into the sub-mucous coat, injuring blood-vessels in its course. By far the most voluminous statistics that we have in regard to its occurrence in both the child and the grown person are those of Welch, given in his masterly article on simple gastric ulcer in Pepper's "System of Medicine."<sup>1</sup>

In six hundred and seven cases of ulcer of the stomach found post mortem and collected by Rokitansky,<sup>2</sup> Starcke,<sup>3</sup> Lebert,<sup>4</sup> Chambers,<sup>5</sup> Habershon,<sup>6</sup> and Moore,<sup>7</sup> only one occurred between the ages of one and ten years, and thirty-two from ten to twenty years. Lebert found by diagnosis during life but one case between the ages of five and ten years in two hundred and forty-seven cases, and Rokitansky in his enormous experience saw only one instance of the disease under fourteen years of age.

Rehn<sup>8</sup> has analyzed all the cases up to 1874, and finds that only six or seven of the reported cases stand examination as cases of simple ulcer, and in these the ages varied from seven days to thirteen years. In the case of Busch<sup>9</sup> an ulcer was found on the anterior wall of the stomach of a boy aged seven days, as large as a one-cent piece, on the greater curvature near the pylorus; it extended in depth through the muscular coat to the serous.

The case of Binz<sup>10</sup> occurred in a girl of eleven days, the ulcer being

<sup>1</sup> Vol. ii. p. 483.

<sup>2</sup> Oesterreich. Med. Jahrbuch, 1839, Bd. xviii.

<sup>3</sup> Deutsche Klinik, 1870, Nos. 26-29.

<sup>4</sup> Krankheiten des Magens, Tübingen, 1878, p. 180 et seq.

<sup>5</sup> London Journal of Medicine, July, 1852.

<sup>6</sup> Diseases of the Stomach, 3d ed.

<sup>7</sup> Trans. Path. Soc. Lond., 1880.

<sup>8</sup> Jahrbuch für Kinderheilkunde, N. F., 1874, Bd. vii. p. 19.

<sup>9</sup> Hufeland's Journal, July, 1836, p. 123.

<sup>10</sup> Berliner Klinische Wochenschrift, 1865, Nos. 15 and 16.



situated on the smaller curvature between the fundus and the pylorus. That of Billiard<sup>1</sup> was in a child of fifteen days, and was placed in the pyloric third of the stomach on the greater curvature. In Donnes's case<sup>2</sup> healing of the ulcer occurred in a three-year-old girl, although it was the size of a ten-sous piece. It was situated on the upper half of the smaller curvature. Gunz<sup>3</sup> diagnosed and found a simple ulcer at the pylorus on the greater curvature; while the case of Rubz<sup>4</sup> was in a thirteen-year-old girl, and was followed by perforation on the smaller curvature.

Since the researches of Rehn were published, six more cases have been reported. Of these, Reimer<sup>5</sup> reports one in a child three and a half years old, Goodhart<sup>6</sup> one thirty hours after birth, Eröss<sup>7</sup> one in a girl of twelve years who was suffering from miliary tubercle and in whom the ulcer perforated the omental sac, and Malinow<sup>8</sup> one in a girl of ten years.

The fifth case is recorded by Barlow<sup>9</sup> as occurring in a child of twenty-one months. On the anterior wall of the stomach at the cardiac end, close to the greater curvature, there was an oval ulcer one-eighth to one-quarter of an inch broad. The edges of the space were undermined, and loss of substance extended almost to the peritoneum. There was no thickening around the spot, neither was there any evidence of tubercular change near by. Besides this ulcer there were two smaller ones on the greater curvature about in the middle zone of the stomach, and two others near the pylorus,—in all, no fewer than five distinct ulcers. There was miliary tuberculosis everywhere else in the body.

The sixth case is recorded by Talamon<sup>10</sup> as occurring in a child of four and a half years, which was under the care of Triboulet in the Hôpital Sainte-Eugénie. After death no fewer than seven tubercular ulcers were found scattered over the surface of the stomach, which was considerably dilated. Two ulcers were at the pylorus, two at the cardiac end of the stomach, and three on the greater curvature.

Curiously opposed to all this evidence is the statement made by several reliable investigators, notably by Buhl and Hecker,<sup>11</sup> Binz,<sup>12</sup> Spiegelberg,<sup>13</sup> and Landau,<sup>14</sup> that one of the most frequent causes of gastric hemorrhage in

<sup>1</sup> Krankheiten der Neugeborenen und Säuglingen, übers von Meissner, 1829.

<sup>2</sup> Rilliet et Barthez, vol. i. p. 883.

<sup>3</sup> Jahrbuch f. Kinderheilkunde, V. Jahrg., H. 3, S. 161.

<sup>4</sup> Gazette Médicale, 1843, p. 673.

<sup>5</sup> Jahrbuch für Kinderheilkunde, N. F., 1876, Bd. x. S. 289.

<sup>6</sup> Trans. Path. Soc. Lond., 1881, xxxii. 79.

<sup>7</sup> Jahrbuch für Kinderheilkunde, 1883, Bd. xix. p. 331.

<sup>8</sup> Index Medicus, 1883, vol. v. p. 575.

<sup>9</sup> Trans. Path. Soc. Lond., vol. xxxvi.

<sup>10</sup> Bulletin de la Société Anatomique, 4e sér., 1878, tome iii. p. 374.

<sup>11</sup> Klinik der Geburtskunde, ii. 243.

<sup>12</sup> Jahrbuch für Kinderheilkunde, 1869, ii. 333.

<sup>13</sup> Perforirendes Magengeschwürn bei Neugeborenen, Berliner Klinische Wochenschrift, 1865, Nos. 15 and 16.

<sup>14</sup> Ueber Melaena, Habilitationsschrift, Berlin, 1874.

the new-born is ulcer of the stomach or duodenum dependent upon emboli from thrombosis in the umbilical vein. (See section on gastric hemorrhage.)

**Prognosis.**—The prognosis is unfavorable.

**Treatment.**—The treatment of gastric ulcer in children should be very much the same as that in adults, save in the fact that, as the lesion usually occurs in strumous and tubercular cases, attention is to be directed to the general health and to the use of those foods which will conduce to health and strength and at the same time not interfere too greatly with the stomach.

In the way of drugs internally we would recommend the alkalies and bismuth, or small doses of opium. Nitrate of silver in small amounts, frequently repeated, combined with belladonna or opium, is of great value in all such cases and should be persistently employed. Counter-irritation should be applied to the belly for the relief of the pain and tenderness and to relieve the local congestion and affect the morbid process favorably. This counter-irritation, in our opinion, should be of the mild continuous type rather than of the severe and fleeting character, and for this purpose the ordinary spice plaster, made of pepper, cinnamon, allspice, and cloves, may be employed. In the collapse following hemorrhage or perforation into the abdominal cavity, the cardiac stimulants should be carefully and guardedly administered, lest by an excessive action they increase the hemorrhage, while for the direct resuscitation of the patient external heat and rubbing of the extremities should be resorted to. Bordeaux wine, preferably of considerable age, should be employed as a stimulant if the use of alcohol is to be kept up for any time. In the early stages of the collapse the alcohol should be hot and fairly concentrated. If the patient is conscious, small pieces of ice may be swallowed to control the hemorrhage, and ergot may be given with the same object in view.

The vomiting should be stopped, since it may increase the hemorrhage, and for this purpose the usual remedies are to be employed, including both those which act centrally and those which act peripherally. Bromide of sodium in weak solution may be injected into the rectum for this purpose.

In regard to the diet, it should be light and easily assimilated, and should be one whose chief digestion and assimilation will be intestinal, not gastric, since by this means we largely avoid the exposure of the raw surface of the ulcer to the acid gastric juices. In some cases the patient should be fed only by the rectum, by means of artificially digested food, which is very useful also when given by the stomach.

#### GASTRIC CANCER.

**Synonyme.**—Carcinoma of the stomach.

Primary gastric cancer is an exceedingly rare disease in childhood, and in reality exists only as a medical curiosity. Steiner and Neurentter<sup>1</sup> failed

---

<sup>1</sup> Prager Vierteljahrschrift, vol. lxxxix. p. 77.

to find a single instance of it in two thousand autopsies made upon children, notwithstanding the fact that the lesion was particularly sought for. A similar experience has been reported by pathologists all over the world, the only instances which we have been able to find being those of Cullingworth,<sup>1</sup> Kaulich,<sup>2</sup> Wilkinson,<sup>3</sup> and Scheffer.<sup>4</sup> In the first of these a cylindrical-celled epithelioma was found in the stomach of a child of but five weeks, and the extreme youth of the subject has led Welch<sup>5</sup>—with justice, we think—to the conclusion that the growth must have been congenital. The case of Kaulich was in a child of one and a half years, and, as all the other organs were involved, it is doubtful whether the disease was primary in the stomach. Wilkinson's case is still more open to question, as it is by no means positive that the disease was not a mere hypertrophy. The case of Scheffer was an encephaloid mass, found by Recklinghausen, with secondary involvement of the spleen. Another case which should perhaps be included in the list is that of Jackson,<sup>6</sup> occurring in a boy of fifteen years, in whom no symptoms appeared till within ten weeks of death.

Widerhofer's<sup>7</sup> case, sometimes recorded as one of cancer, was probably secondary from retro-peritoneal sarcoma.

**Symptoms.**—The symptoms of gastric cancer in children are to be gathered only from the isolated cases which have been reported, and from the symptoms as they appear in the adult.

Pain is, of course, one of the most marked signs of the disease, and is lancing and of a severe character, extending to the hypochondrium or downward towards the umbilicus. The rest at night is much broken, and loss of appetite is a prominent symptom from a very early period in the course of the malady. Vomiting of the food, with or without blood, may be a symptom, and there is always a high grade of wasting and cachexia. Irregular intermittent attacks of fever are common, and if the growth is properly situated or large there may be more or less dyspnoea.

The treatment of gastric cancer is, of course, directed solely to the relief of pain and the comfort of the sufferer. The diet should consist of easily-digested and softened food.

The prognosis is necessarily fatal, and the main effort should be to relieve pain by morphine and similar drugs.

#### HEMORRHAGE FROM THE STOMACH, AND HÆMATEMESIS.

**Definition of Gastric Hemorrhage.**—Gastric hemorrhage is, as its name implies, a condition in which, by reason of a solution of continuity

<sup>1</sup> British Medical Journal, August 25, 1877.

<sup>2</sup> Prager Med. Wochenschr., 1864, No. 34.

<sup>3</sup> London and Edinburgh Monthly Journal of Medicine, 1841, vol. i. p. 23.

<sup>4</sup> Jahrbuch f. Kinderheilkunde, 1880, Bd. xv. S. 425.

<sup>5</sup> Pepper's System of Medicine, vol. ii.

<sup>6</sup> Extracts from Proc. Boston Soc. for Medical Improvement, 1867, vol. v., Appendix, p. 109.

<sup>7</sup> Jahrbuch f. Kinderheilkunde, Alte Reihe, Bd. xi. II. 4, p. 194.

in a blood-vessel wall, blood gains access to the cavity of the stomach. It is to be carefully separated from hæmatemesis, which is not necessarily associated with a break in a gastric blood-vessel, and is merely a term defining a symptom, not a lesion.

Thus, hæmatemesis may be due to the swallowing of blood from a wound in the mouth, the throat, or the lung, or even to the ingestion by a malingerer of the blood of some animal. True hemorrhage from the stomach is quite rare in childhood, some of the most common causes of its occurrence being purpura hæmorrhagica, the hemorrhagic diathesis, and kindred states. Aside from these causes, such an accident as the ingestion of sharp foreign bodies or of corrosive acids or alkalies may produce it. In girls about puberty such a symptom may be an evidence of a vicarious menstruation.

In very young children, gastric congestion the result of obstruction in the portal system or of inherent laxity of the gastric veins is a very common cause of the state known as *melæna neonatorum*, a gastric hemorrhage which frequently comes on during the first few days or weeks of life. It has been thought by some that a predisposing cause of this occurrence is difficult respiration after birth, resulting in general venous stasis; but this is hardly probable, since other vessels ought for the same reason to prove incompetent.

Leube states that the majority of these cases depend upon the existence of gastric and duodenal ulcers, but this would seem, from published statistics, very unlikely. On the other hand, Buhl and Hecker,<sup>1</sup> as well as Spiegelberg,<sup>2</sup> Binz,<sup>3</sup> and Landau,<sup>4</sup> assert that in the examinations made by them such lesions were almost always present. In a case of Landau's there was a thrombosis of the umbilical vein, and it has been asserted that, when the expansion of the chest takes place in the new-born child, small clots may escape from this vessel through the ductus arteriosus into the descending aorta and gastric arteries, and thus cause the formation of an ulcer in a manner similar to that which occurs in a round ulcer in the adult. Again, Landau believes that the same result may be reached by an embolus derived from the umbilical vein, which, being driven through the ductus venosus, enters finally the ductus arteriosus and descending aorta and so gives rise to gastric embolism.

As the researches of Cohnheim have clearly shown, venous stasis may cause oozing through the blood-vessel walls, and this may cause hæmatemesis.

In athrepsia in the new-born, Hutinel<sup>5</sup> states, there is to be found a normal gastric and intestinal epithelium, but always, where the wasting is

---

<sup>1</sup> Klinik der Geburtskunde, ii. 243.

<sup>2</sup> Jahrbuch für Kinderheilkunde, 1869, Bd. ii. S. 333.

<sup>3</sup> Berliner Klinische Wochenschrift, 1865, Nos. 15 and 16.

<sup>4</sup> Ueber Melaena, Habilitationsschrift, Breslau, 1875.

<sup>5</sup> Contribution à l'Étude des Troubles de la Circulation veineuse chez l'Enfant et en particulier chez le Nouveau-né, Hutinel, Paris, 1877.

acute, a dilatation of the small veins and passive congestion of the whole digestive tract. By this means the circulation is disordered, absorption is stopped, and secretion is altered. Rarely this goes on to hemorrhage from the dilated blood-vessels.

Malarial fevers are capable of producing gastric hemorrhages as well as hemorrhages from the kidneys and intestines. Boon<sup>1</sup> has recorded a case in which gastric hemorrhage was the evidence of tertian ague and was cured by quinine.

Hemorrhages from the stomach may also occur in scurvy, yellow fever, and acute yellow atrophy of the liver, under which circumstances the leakage of blood depends upon the changes in the constitution of the blood itself. In the adult, females are by far the most commonly affected,—according to Handfield Jones,<sup>2</sup> in seventy-four per cent. of the cases. Whether this is true in children I do not know.

**Symptoms.**—Gastric hemorrhage may, if the amount of blood be very small, go on intermittently for long periods of time without notice, owing to the escape of the liquid into the bowel. If, however, the amount be large, the black, fetid, tarry stools will show its presence at once. If the hemorrhage be severe, long before its presence is evidenced by the stools, symptoms of loss of blood will assert themselves. In addition to the pallor and collapse always present, there will be oppression and a sense of weight in the stomach, finally going on into faintness and perhaps death. Vomiting sometimes comes on very early, and is typical of the disorder. If the hemorrhage be profuse and the vomiting be rapid in its onset, the blood expelled will be red and normal in hue. If the blood remain in the stomach for any length of time, it will be coffee-colored (coffee-ground), from the action on it of the gastric juice.

A very extraordinary accident sometimes occurs after gastric hemorrhage, and, while we know of no recorded case in the child, there is no reason why it should not occur,—namely, double permanent blindness. This amaurosis does not depend on the anæmia which causes this symptom so commonly in the parturient state, for it occurs where the hemorrhage is not severe enough to be noticeable, and does not leave when the system recovers its normal quantity of blood. Such instances are recorded by Fikentscher<sup>3</sup> and Von Graefe.<sup>4</sup>

**Diagnosis.**—If the amount of blood is very small, so that the vomit is very slightly tinged, the question at once arises as to whether the discoloration depends on hemorrhage or on some other cause. This can be determined by a microscopical examination, unless the blood is completely broken down. If this does not give us all the information we desire, we may resort to the

<sup>1</sup> *Annales de la Soc. de Méd. d'Anvers*, Dec. Ref. Canstatt's Jahresbericht, 1870, ii. 218.

<sup>2</sup> *Hæmatemesis*, *Medico-Chirurgical Transactions*, xliii. 353.

<sup>3</sup> *Fall von plötzlichlicher Amaurose*, etc., *Arch. f. Ophthalmolog.*, viii. 209.

<sup>4</sup> *Zwei Fälle von plötzlichlicher und incurabler Amaurose*, *Arch. f. Ophthalmolog.*, vii., 2 S., p. 143.

test for hæmin,<sup>1</sup> as follows: Dry a small quantity of the blood at a low temperature, place a few particles of the dried mass on a glass slide, add two or three drops of glacial acetic acid and a small crystal of common salt, cover with a cover-glass, and heat gently over the flame of a spirit-lamp until bubbles of gas are given off. On cooling, crystals of hæmin appear.

After deciding that blood is present, it remains to be ascertained whether the blood is or is not directly from the stomach. The throat, mouth, and nose should be carefully examined, to discover any flow of blood from these places. I regard the posterior surface of the pharyngeal wall as a spot which should be carefully examined under these circumstances, because hemorrhages may very readily occur from this region from over-distended capillary vessels, and by the constant oozing ultimately cause the unconscious swallowing of a large amount of blood and at the same time make no show of a local clot or undue redness. Such a case was seen by me but a short time since.

By far the most common question for differential diagnosis lies between hæmoptysis and hæmatemesis. Thus, the former may cause the latter, or so much coughing may accompany the expulsion of the blood as to make it difficult to decide from which part the blood comes. If the vomit comes first and the cough secondarily, the hemorrhage is probably from the stomach. The absence of a history of pulmonary involvement and of pulmonary signs at the time of the attack, and the dark blood of hæmatemesis, separate it from hæmoptysis also. Again, the reaction of the blood of hæmatemesis is generally acid, while that of the blood of hæmoptysis is alkaline.

**Prognosis.**—This depends entirely upon the primary causes of the hemorrhage and upon the severity of the lesion producing it. If tuberculosis is the cause, the prognosis is hopeless. If, on the other hand, malaria or a kindred agency is at work, the case is more hopeful. The immediate danger of death from hemorrhage is not excessive.

**Treatment.**—The treatment of gastric hemorrhage is necessarily an immediate one, and after the active flow is past our attention must be turned to the prevention of other attacks. The methods to be followed with such a hemorrhage are almost identical with those applicable to all internal hemorrhages. Cardiac stimulants are to be avoided until the hemorrhage is completely controlled, for the same reasons that they are to be forbidden in external hemorrhages before the bleeding vessel is ligated. Perfect rest, flat on the back, is to be insisted upon. If the child is old enough to be frightened, his fears should be allayed by assurances of recovery, and every effort made to quiet any excitability of the patient and his friends, whose alarm often leads them to say things lacking in tact and calculated to disturb the needful rest. Probably the best styptic to be

---

<sup>1</sup> Hæmoglobin cannot be tested for, as the gastric juice breaks it up into globulin and hæmin or hæmatin.

employed is Monse's solution; in the dose of from one to three drops in a small amount of water. Tannic acid may also be freely given. It should not be forgotten, however, that these should not follow each other, as they are incompatible. Food should be withheld for several hours, in order that the clot may be thoroughly formed in the opening in the blood-vessel and not readily dissolved by the gastric juices. All coarse or hard foods, such as toasts or bread-crusts, are entirely out of place, and only foods which are emollient in their character are to be given. If great systemic disturbance and lowering of bodily heat have occurred, ice internally is contra-indicated, and heat is to be used externally. Thirst is best relieved by pieces of ice held in the mouth or by rinsing the mouth out with a little water. If the vomiting is persistent, it is to be treated as would be any case of hyperemesis,—by mustard plasters applied over the belly and to the feet, and by small doses of aconite and other gastric sedatives; or, if the vomiting seems to be centric in its origin, bromide of potassium may be given by the rectum in moderate amounts. Morphine and opium are not indicated, for the double reason that no particular benefit will accrue from their use and that they are apt to be harmful in children.

If the hemorrhage is severe enough to endanger life, transfusion is to be resorted to, using preferably a solution of common salt of the strength of seven per thousand of water, thoroughly clean and free from foreign bodies or undissolved masses. A much better solution, however, for transfusion is one composed of tribasic phosphate of lime and potassium chloride in the proportion of one hundred cubic centimetres of a saturated solution of the former to five cubic centimetres of a one-per-cent. solution of the latter. It should never be forgotten that transfusion is to be used as a last resort, and also that cases are on record in adults in which death has been produced by the rise in blood-pressure being followed by a free renewal of the hemorrhage.

#### DISPLACEMENTS OF THE STOMACH.

In childhood these displacements are, like the deformities, congenital. In some instances the stomach escapes through an opening in the diaphragm into the thorax. In other cases the diaphragm is entirely absent. Where there is entire transposition of the viscera the stomach is of course reversed also. Epstein<sup>1</sup> and Küchenmeister record such cases. While the latter displacements are very rare, the same thing cannot be said of those cases where the diaphragm has failed to keep the foreign viscus out of the thorax.

Thus, Holt<sup>2</sup> has recorded an instance in a two-year-old child where the stomach was found in the chest. Boyer<sup>3</sup> records an instance occurring in a five-year-old child, and Dimerbroek one in a child of seven. Schrandt<sup>4</sup>

<sup>1</sup> Jahrbuch für Kinderheilkunde, Bd. xxiv. Heft 2, p. 215.

<sup>2</sup> Philosophical Transactions, 1702, No. 275.

<sup>3</sup> Maladies Chirurgicales, tome iv.

<sup>4</sup> Nederl. Weekblad, Maart en April, 1854.

records an extraordinary case in a boy of fifteen years in which the hernia was complete.<sup>1</sup>

#### GASTRIC DEFORMITIES.

Gastric deformities present in childhood are nearly always congenital, the only other conditions being strictures and adhesions caused by corrosive poisons. Stenosis of the pylorus, of which we have already spoken, is a form of such malformation, of course, and we may also have pyloric incompetence. Where congenital constrictions exist, the viscus may be partitioned into sacculations. In some instances the stomach is a mere blind pouch connected by a fibrous cord to the duodenum, or else it is not connected with the intestine at all.

Musser<sup>2</sup> records a case of congenital "hour-glass contraction" of the stomach. The contraction took place in the centre, and was transverse; the peritoneum and submucous connective tissue were thickened at this point. Anterior to the constriction the muscular coat was hypertrophied.

#### GASTROMALACIA.

**Synonyme.**—Softening of the stomach.

Formerly it was supposed that the softened condition of the stomach found in some cases after death was an ante-mortem pathological change characteristic of a particular disease in the child. At present, however, this theory has been entirely set aside, and we know that the change is post-mortem in its production and depends on the action of the gastric juice on the surface of the stomach. In some instances the morbid change is limited to the mucous membrane; in others it extends through all the coats, so that a soft, irregular ulcer is formed, which perforates the viscus and allows the food to escape into the peritoneal cavity.

The morbid process most frequently affects the fundus, and, as the stomach is generally congested in this area, the whole appearance closely simulates that of active ante-mortem change. Though Welch<sup>3</sup> asserts very positively that the changes are altogether *after* death, yet Goodhart<sup>4</sup> believes that they may occur just prior to dissolution, being due at this time to defective gastric circulation, so that the walls are not supplied by alkaline fluid as they should be. Of course this state is really identical with the post-mortem change. Day,<sup>5</sup> writing so late as 1881, regards it as a true disease, but states candidly that he is unable to give any characteristic symptoms which would enable any one to diagnosticate the trouble before death. If the lesion is in any case ante-mortem it is, as Goodhart has well said, "the result of an ebbing life, not a disease which caused death."

<sup>1</sup> For much interesting material concerning this subject, see Schmidt's *Jahrbücher*, 1856, Bd. lxxxix. S. 169; also Rokitsansky, *Lehrbuch*, iii. 181.

<sup>2</sup> *Proc. Path. Soc. Phila.* See *Philadelphia Medical Times*, Jan. 26, 1884.

<sup>3</sup> *Pepper's System of Medicine*, vol. ii. p. 618.

<sup>4</sup> *Diseases of Children*, Amer. ed., 1885, p. 134.

<sup>5</sup> *The Diseases of Children*, London, 1881, p. 181.



# THE DIARRHŒAL DISEASES,

## ACUTE AND CHRONIC.

BY L. EMMETT HOLT, M.D.

---

AT the present time medical opinion is in somewhat of a transition stage in regard to the pathology of diarrhœal diseases. Many ancient fallacies have been exposed and dropped, but the building up of newer views upon surer foundations than those upon which the old rested is slow, and can scarcely be said to be much more than begun. We know enough to know that micro-organisms play an important part in these diseases, but which ones, and how, are still to a large degree unsolved problems. I have endeavored to look at diarrhœal diseases in the light of present knowledge, but not to go further than the state of knowledge would seem to warrant.

The difficulty in classifying these cases is at present very great, and the classification here offered has many points which are open to criticism, but it seems to satisfy present needs better than any other. One who sees autopsies upon his cases of intestinal disease is continually struck with the fact that there is a great disproportion between the symptoms and the lesions, and that essentially the same symptoms may exist with quite a diversity of lesions. A classification, then, which is based entirely upon the pathological findings becomes complicated and needlessly confusing to the clinician. I have tried to solve the difficulty by introducing a general section upon pathological anatomy in which the different lesions are considered *seriatim*, and in the further discussion to make a classification upon a purely clinical basis. Accurate etiological classification can be reached only when this subject has been cleared up by experimental bacteriology.

The propriety of introducing a separate section upon Dysentery has been carefully considered, but the question has been decided in the negative, for the following reasons. The common view that in diarrhœa we have to do with lesions in the small intestine, while the lesions of dysentery are in the colon, is entirely overthrown by the post-mortem findings. The truth is that in by far the largest number of cases classed clinically as "diarrhœa" the principal lesions are found in the large intestine, while in

the cases of so-called "dysentery" lesions are almost invariably found in the lower ileum as well as in the colon.

Ulceration, high temperature, blood and mucus in the stools, and even infection, are not peculiar to dysentery. Ulceration and even pseudo-membrane are found in cases which were clinically only diarrhoea; the same is true of high temperature. Blood may occur in a great variety of conditions, and mucus is common to almost every case of intestinal disease in some stage. Furthermore, the evidence is now pretty convincing in favor of the opinion that several varieties of diarrhoea are infectious. We have left, then, only tenesmus, with or without the appearance of blood and mucus in the stools, as separating dysentery from diarrhoea. This group of symptoms depends not upon the nature of the pathological process, but upon its seat; tenesmus, with painful expulsive efforts, occurring with inflammation involving the rectum and lower colon when it reaches a certain degree of intensity.

It has seemed to me, then, better to abandon the use of the term "dysentery" as signifying a special form of disease; while perhaps it is desirable to retain the terms "dysenteric symptoms" or "dysenteric stools" to characterize certain forms of colitis or entero-colitis in which the inflammatory process is principally in the lower fourth of the large intestine. With a clear understanding of just what is meant by the term, its retention in the nomenclature of intestinal diseases cannot be objected to.

Those who consult these articles to find formulæ will be disappointed. The day of composite prescriptions containing half a dozen different ingredients or more is fast passing away. The administration in diarrhoea of mixtures containing an opiate, an astringent, an alkali, a stimulant, an antiseptic, and a ferment (and many such are constantly employed) is not only unscientific, but also useless. In many of these time-honored formulæ their value depends upon a single ingredient, or at most two, the others being very often positively injurious.

The routine use of certain complicated formulæ because some writer has lauded them as "good for diarrhoea" cannot be too much condemned. Simple prescribing is everywhere desirable, especially so in children, and most of all in diseases of the gastro-intestinal tract, where unnecessary drug-giving is almost certain to do harm.

---

## I. GENERAL ETIOLOGY OF DIARRHOEAL DISEASES.

**Age.**—Statistics upon this point will vary somewhat according to the source from which they are taken. Those from large foundling asylums show the greatest frequency among children who are under six months of

age. The following figures are from my own service in the children's class of the Northwestern Dispensary, and include those applying for treatment for diarrhœal diseases during five years, classified according to age :

First six months . . . . .	119 cases.	Fourth six months . . . . .	125 cases.
Second six months . . . . .	237 "	Over two years . . . . .	$\frac{142}{772}$ "
Third six months . . . . .	149 "	Total . . . . .	772 "

The mortality-records of the New York Infant Asylum give almost identical proportions for the different periods. In this institution the infants are, as a rule, nursed by the mothers. The children are born in the asylum, and the majority remain until they are two years old. These figures, then, may be taken to represent fairly the relative frequency of diarrhœal diseases at the different ages everywhere except in foundling asylums. They show a much greater susceptibility between the ages of six and eighteen months, and confirm the popular impression as to the dangers of the "second summer." These facts are, however, to be taken in connection with those regarding diet.

**Surroundings.**—While diarrhœal diseases are relatively more frequent in the city than in the country, and more frequent among the poor than among the well-to-do, still we cannot say that they are essentially diseases of the city, or of poverty. We meet with plenty of severe and even fatal cases among the rich and in the country, both at the sea-side and in the mountains. Although some experiments of Tompkins,<sup>1</sup> in Leicester, England, seem to show that bacteria are very much more numerous in the air in districts where diarrhœal diseases are prevalent, we have not yet accumulated sufficient evidence to establish the fact that there is a direct connection between a polluted atmosphere and their prevalence. Nor has any relation to bad sewerage been proved. They are not essentially filth-diseases, yet their frequency and severity are both increased by want of cleanliness in apartments, in the persons and clothing of infants, especially the diapers, chiefly, it appears, as these lead to a contamination of the food. Vacher<sup>2</sup> has shown that diarrhœa-mortality in the large English towns had no constant relation to the density of population.

In regard to dwellings, Meinert,<sup>3</sup> who investigated five hundred cases in Dresden, found the highest mortality among those living on ground-floors, which he suggests is due to greater heat here and atmospheric stagnation. Baginsky,<sup>4</sup> however, found in Berlin the highest mortality among those dwelling in basements.

Poverty, want of care, close and ill-ventilated rooms, predispose to diarrhœal diseases in summer, just as they do to pneumonia and bronchitis in winter, but it is doubtful if they do so to any greater degree. The predisposition in both cases is general and constitutional.

**Constitution.**—While it cannot be said that any special vice of constitution predisposes to these diseases, everything which lowers the general vitality increases the liability. In every large city there are seen congre-

gated in its asylums or scattered among its tenement-population a great number of infants who are "born to die." They are swept off every summer in immense numbers by intestinal diseases, in winter by pneumonia. In every epidemic of diphtheria or scarlet fever they make up a large majority of the fatal cases. Those who treat diarrhoeal diseases only in the country or among the better classes can but faintly appreciate the importance of this constitutional factor. These are the cases which must die, no matter where treated or how.

Children who suffer from athrepsia, syphilis, rickets, or tuberculosis are especially prone to be affected; likewise those with pneumonia, measles, diphtheria, and particularly pertussis.

**Dentition.**—There are a certain number of cases in which diarrhoea and dentition are associated, and where a pretty close connection between the two seems to exist, for the bowels quickly become normal when the teeth have pierced the gum. Such cases are rare, yet they do occur. Too much, however, cannot be said in contradiction of the wide-spread belief among the laity, that diarrhoea occurring with dentition is normal and even beneficial. Such a view costs many lives every year.

The immunity from diarrhoeal diseases during dentition in the cold season is the best argument against the importance of this as an etiological factor. It is certainly a very minor consideration.

**Diet and Feeding.**—Of 1000 fatal cases recorded by Hope,<sup>5</sup> 30 had the breast exclusively; of 602 fatal cases recorded by Meinert, 24; and of 341 fatal cases recorded by Ballard,<sup>6</sup> 7; making a total of 1943 fatal cases, of which 61, or about 3 per cent., had the breast exclusively.

These facts speak volumes. They show that the manner of feeding is one of the most important factors in the production of diarrhoea. These facts are to be connected with those cited with reference to age. The poor in New York nurse their infants, as a rule, for about six months. If nursing is continued longer it is with the addition of other food, which is very often of the most indigestible kind and totally unfitted for infants. We find here incidental evidence bearing upon the same point as the figures of Hope and the others. As long as children are nursed entirely they suffer but little from diarrhoeal diseases, but, in the same class of children, as soon as the age is reached when other food is added we find a very marked increase in this frequency. Children among the poor in tenements enjoy immunity from intestinal disease just in proportion as they are nursed at the breast, and just so long as they are so, but as soon as artificial feeding is begun diarrhoeal diseases begin to be prevalent.

Why is it that artificial feeding among all classes, but among the poorer classes especially, is so dangerous? One of the oldest reasons assigned was the chemical composition of cow's milk, its indigestible casein, cow's milk being the almost universal substitute for the breast. To this subject much attention has been given, and, as Baruch<sup>7</sup> very well points out, all the refinements in the chemical analysis of milk have not brought us one step nearer

the practical solution of the problem. Children continue to thrive upon it in winter and to get diarrhœa in the summer, dilute, sweeten, or change it as we may. Its safety in winter and in the country shows conclusively that the chemical composition of the milk is not an important factor, if indeed it plays any part.

Again, the manner in which hand-feeding is done has been blamed, and justly so. Hand-fed children are almost always overfed. It is a common practice among the poor for a large bottle supplied with a long nursing-tube to be filled and put beside the infant in its crib, allowing it to eat or sleep just as it likes; sleeping often for hours with the nipple in its mouth, or, more frequently, waking every few minutes for a few pulls at the bottle. Frequent feeding night and day, or rather this almost constant feeding, together with overfeeding, is in itself productive of great harm, even where the food given is all that it should be.

Articles of food unsuited to the child's age are often given. The practice of feeding infants only a few months old with "a taste from the table" is a common one among the poorer classes. Before an infant is a year old, potatoes, tea and coffee, beer, stews, sausage, and many other things equally indigestible, are given as a regular thing. Children at eighteen months often get only the regular diet of the family.

Almost all the diarrhœal attacks after the age of two years can be traced directly to improper food. The excessive use of starchy foods in early infancy is believed by many writers to be an important cause of diarrhœa. I think this point has been somewhat exaggerated.

The foregoing factors—overfeeding, irregular feeding, too frequent feeding, and the habitual use of improper articles of food—all unite in producing chronic infantile indigestion, and this chronic dyspepsia is more important than all other factors as a predisposing cause of diarrhœal diseases.

In nursing children diarrhœa is caused rarely by drugs given to the mother, or by dietetic errors on her part; frequently by menstruation or pregnancy, or by nervous influences, such as grief, exhaustion, etc.; sometimes by anæmia.

Impure cow's milk is an important cause. It may be due to disease in the cow, to the care and food of the cow, to adulteration or pollution of milk in the process of transportation and delivery, to dirty utensils, pails, pans, or cans in which the milk is kept, or to dirty bottles from which it is fed.

Almost all these changes are believed to depend upon the entrance of bacteria and their growth, and they will be more fully discussed in the next section.

The readiness with which impure cow's milk causes diarrhœa may be seen from the following circumstance. In the New York Infant Asylum on one occasion every one of twenty-three healthy children occupying one ward, all over two years of age, was attacked with diarrhœa in a single day. On investigation the cause was traced to the milk.

**Contagion.**—Hope,<sup>8</sup> investigating six hundred and thirty-four fatal cases, found that in sixty per cent. of the families “other cases of diarrhoea, more or less severe and generally among children,” existed. In very many of these, of course, a common exciting cause is very probable, since the food, the manner of feeding, surroundings, etc., would be the same or similar in all the young children of a family. Lesage<sup>9</sup> has recorded the following experience. In a certain ward there were during the month of October no cases of diarrhoea. At the end of the month a case of “green diarrhoea” was admitted, and within six days eight other cases developed, six of these being in hand-fed children. In most small epidemics we have many cases developing simultaneously rather than successively, and this suggests a common origin for all.

Many such instances must be collated and studied before we can consider the contagion of certain forms of diarrhoeal diseases as an established fact; but we know enough about the spread of typhoid fever and cholera from the poison of the discharges to make it our duty to insist upon the most careful disinfection of napkins and stools, particularly in summer. (See Prophylaxis.)

**Foreign Bodies.**—These may be ingested as food, such as partially-cooked rice or other cereals, dried fruits, raisins or currants, chunks of meat, raw vegetables, celery, radishes, etc., and green fruits. As these are not capable of digestion by the infant's organs, they act as foreign bodies.

One severe and nearly fatal case is known to me, in which the cause was the swallowing of a quantity of hair which the infant had pulled from a rug upon which it was accustomed to sit. The case lasted nearly three months. Finally a large mass of hair was passed by the bowels. Improvement began immediately, and the case went on to a rapid recovery. Such instances are extremely rare.

**Exposure to Cold.**—There seems still to be some good ground left for the belief that certain cases of diarrhoea, particularly in very young children, do depend upon cold and exposure. Their number is certainly not large, and they are apparently reflex in character.

**Change of Air and Water.**—It is extremely doubtful if a simple change of air or water alone will induce diarrhoea if no other factors are present. The cases usually attributed to such causes are more frequently due to dietetic errors or impure food.

**Weaning.**—This is almost certain to be followed by an attack of diarrhoea if it is done suddenly and in summer. There is nothing peculiar in “diarrhoea ablactatorum.” The same causes are operative here as in all other cases of hand-feeding.

**Telluric and Atmospheric Conditions.**—Certain telluric conditions, the fluctuations of “ground-water,” and the temperature of the soil, have been studied by Baginsky. The variations in the former had no relation to diarrhoea, while there was a pretty close relation between the earth-tempera-

CHART I.

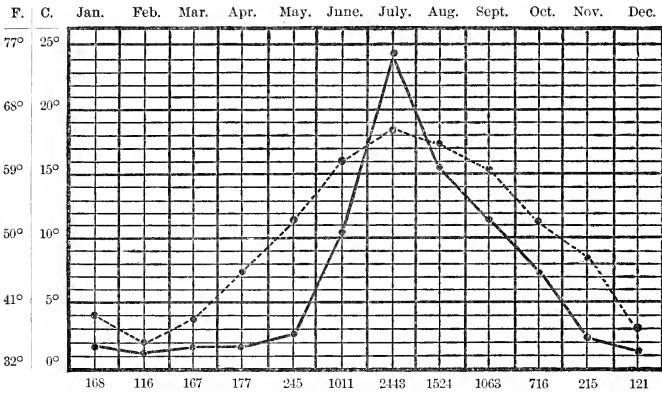

Morbidity of "cholera infantum;" German Dispensary, New York, 1877-1887; 8086 cases, and average monthly temperature. (After Seibert.)

Temperature..... Morbidity\_\_\_\_\_

L. Emmett Holt, M.D.

CHART II.

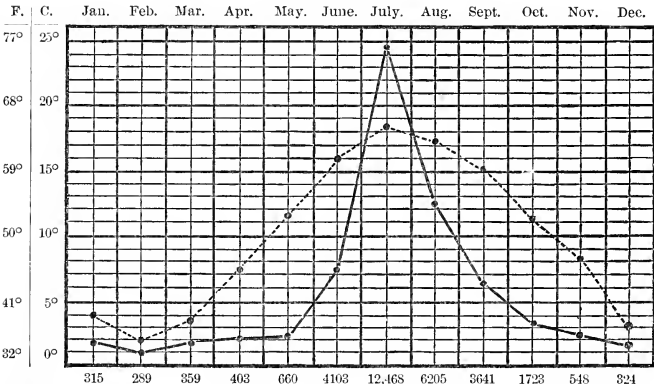

Mortality of diarrhoeal diseases in children under five years of age; New York City, 1877-1887; 31,048 cases, and average monthly temperature. (After Seibert.)

Temperature..... Mortality\_\_\_\_\_

L. Emmett Holt, M.D.





ture and diarrhœa. This earth-temperature depends upon the atmospheric temperature, and it is the latter which he regards as the essential factor.

Ballard,<sup>10</sup> however, concludes, from his observations, that summer rise in diarrhœa does not begin until the earth-temperature at the depth of four feet reaches 56° F., no matter what the height reached at the depth of one foot or in the atmosphere may be; and that it continues without abatement until the temperature at the depth of four feet falls below the degree indicated, whatever the fluctuations or decline in the temperature of the atmosphere.

Tompkins,<sup>1</sup> from observations in the same town (Leicester, England), reaches the opinion that it is the temperature of the earth as recorded by the one-foot thermometer that is the essential one.

With these conflicting opinions, it does not seem that we are yet justified in the conclusion that the rise in frequency and mortality of diarrhœa in summer is in any special or direct way associated with earth-temperatures.

The relation of the different atmospheric conditions to diarrhœa has been the subject of very careful investigation by Seibert<sup>11</sup> of New York, Baginsky of Berlin, and Meinert of Dresden. The unanimous conclusion reached independently by the different observers is that neither barometric pressure, humidity, nor rainfall has any influence whatever upon the prevalence of or the mortality from infantile diarrhœa.

Dr. Seibert found also that in New York neither the direction nor the velocity of the wind had any relation to diarrhœa. Meinert reached a different conclusion upon the second point,—viz., that the highest mortality was with the least wind.

Temperature, then, is the only atmospheric condition which has been found by all observers to be at all closely associated with the prevalence of and mortality from diarrhœal diseases in children.

Chart I., from Seibert, shows the number of cases occurring in one of the large city dispensaries for ten years by months, as compared with the mean temperature for those months; and Chart II., from the same writer, shows the mortality in the city of New York for the same time from diarrhœal diseases in children under five years. These charts, which are almost identical, show, as Dr. Seibert very justly says, that with large figures there is an exact correspondence between the prevalence of these diseases and their mortality.

Chart III. is taken from Baginsky, and exhibits the relation between average temperature and the mortality from diarrhœal diseases among children in the city of Berlin. Chart IV. has been constructed from tables of statistics from the city of Baltimore published by Miller,<sup>12</sup> but covers the six warm months only.

These charts have a remarkably close resemblance to one another; and, taken as they are from widely different points, they may be regarded as showing pretty conclusively the facts regarding mean temperature and mortality from diarrhœal disease.

The charts show a slight rise in the mortality-curve in the month of May, a more marked one in June, and an enormous one in July; a sharp decline again in August, and a gradual one in September and October. During the latter month it reaches the point from which it rose in May.

In comparing these charts it will be seen that the month of May, with an average temperature in New York of 54° F. (12.2° C.) and in Berlin of 55.4° F. (13° C.), has but a little higher mortality than the winter months. In June, with an average temperature of about 61° F. (16° C.), we see a very great increase in the mortality; in New York it is nearly seven times greater than in May.

Vacher states that in London, whose average summer temperature is 59.6° F., every year for the last twenty-five when the death-rate from summer diarrhoea has exceeded three per thousand per annum the average summer temperature has exceeded 60° F. Again, during the same period in five years the annual mortality from this cause was less than two per thousand. These years gave an average temperature of 58.2° F.

We conclude, then, that there is required, for diarrhoeal disease to become epidemic, a certain elevation of temperature, and that this temperature is but a little below 60° F. When near this critical point a difference of only one or two degrees has a very marked influence in increasing the amount of diarrhoea.

In every one of the charts the greatest mortality occurs in July, the month with the highest mean temperature. It is, however, seen that whereas the mean temperature of July exceeds that of June by only 4° or 5° F., the mortality in New York and Baltimore is about three times as great, and in Berlin twice as great. A similar statement can be made with reference to August as compared with July: here the difference in temperature is even less. The natural inference would seem to be that when a certain height of temperature has been reached a rise of a few degrees more leads to an enormous increase in the death-rate; and, further, that the mortality varies directly as the atmospheric heat.

Dr. Seibert, however, has very well pointed out the fallacy to which monthly averages may lead. He has studied every summer month for the ten years separately, as to its maximum and its minimum temperature, and the relation of these to the prevalence and mortality of diarrhoea. These observations show that there is no constant and close connection between the height of the temperature and the amount of diarrhoea: *e.g.*, July, 1879, and July, 1880, had practically the same temperature, and yet the former month showed twice as many cases of diarrhoea. "July, 1887, had eighteen days in which the temperature reached 85° F. and twelve in which it was over 90° F., and yet the number of cases was less than the average for July, and one-third less than July, 1882, which showed only fifteen hot days." "July, 1878, with fourteen hot days, had ninety-nine cases, while July, 1884, with only four hot days, had two hundred and sixty-six." We are, then, forced to the conclusion that there is no constant relation

CHART III.

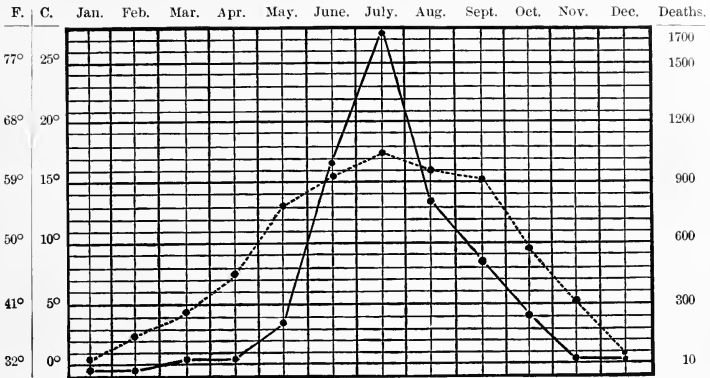

Mortality of diarrhoeal diseases in children under five years of age; Berlin, 1879-1883; 5131 cases, with mean monthly temperature. (After Baginsky.)

Temperature.....

Mortality\_\_\_\_\_

L. Emmett Holt, M.D.

CHART IV.

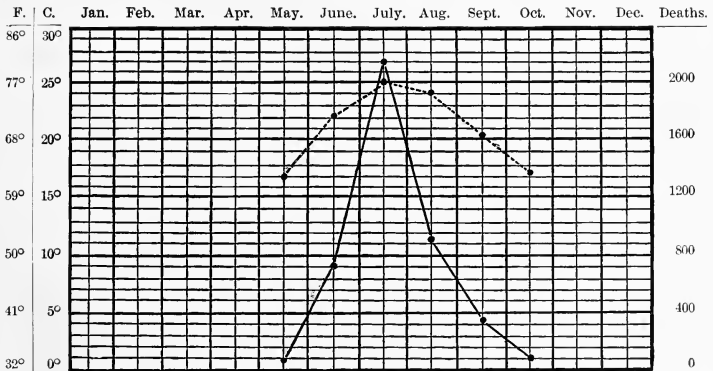

Mortality from diarrhoeal diseases in children under five years of age; Baltimore, 1879-1887; 4390 cases, with mean monthly temperature (warm months only). (After Miller.)

Temperature.....

Mortality\_\_\_\_\_

L. Emmett Holt, M.D.

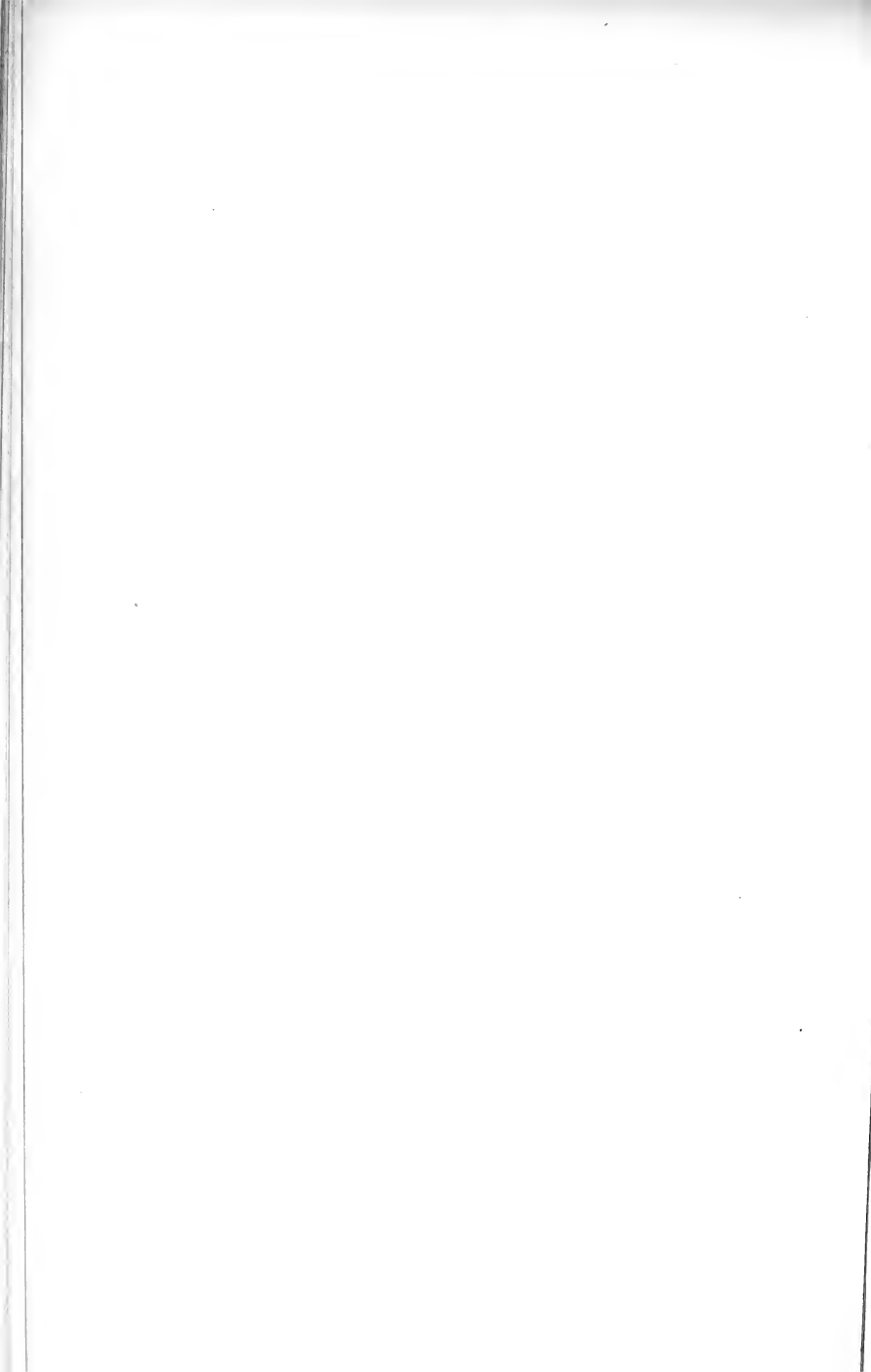

between the degree of heat and the amount of diarrhœa; and consequently we cannot look upon heat as the direct agent which produces diarrhœa.

The same conclusion is sustained by two other facts. Meinert has shown that, in the continental cities of Europe, as we pass from north to south we find the death-rate from infantile diarrhœa *steadily decreasing*. He attributes the difference to the more general practice of maternal nursing in the southern cities, and to their open houses and out-of-door life. The second point is that if the direct effect of heat on the body were the chief cause we ought to find those most affected who would naturally be most susceptible to heat,—viz., the youngest infants. By referring to the figures cited under "Age" it will be seen that infants of the first period of six months suffered less than those of the second six, or even of the third. All the statistics of the relation of manner of feeding to mortality show that it is not because infants are very young, but because they are artificially fed, that they get diarrhœa.

How is the great difference between the mortality-records of June, July, and August to be explained?

All observations show that a succession of several warm days is necessary before the effect is seen in an increased amount of diarrhœa. As our first warm weather in New York rarely comes early in June, it is not until towards the end of the month that the mortality-rate of midsummer begins to appear.

Again, the susceptibility of the children in June is less, since they have just enjoyed the pleasant spring season, and are in comparatively good condition. It is not surprising, then, to find a much higher death-rate in July than in June.

In comparing July with August we find two months of nearly the same average temperature yet with widely different mortality-records. August gives a much smaller number, in spite of the fact that the children have just come through the hottest month of summer. The only reasonable explanation is that there are every summer in the community certain children who by their constitutional condition, their surroundings, and the way in which they are fed are predisposed to diarrhœa. The first hot month, July, sweeps off the largest number of them. I believe this to be the explanation of the relations of the mortality-figures of June, July, and August.

After a certain height of temperature is reached, all the conditions are present for the prevalence of diarrhœa, and increase beyond this point has no constant relation to the amount of diarrhœa. Diarrhœa begins to be common as soon as the average temperature reaches 60° F. It becomes very prevalent whenever the *minimum* temperature does not fall below 60° F.

Is the old idea of the direct action of heat or thermic fever as a cause of diarrhœa to be entirely set aside? Enough evidence has been brought forward already, I think, to show that this is at least not the most impor-

tant action of heat. Still, I cannot resist the conclusion that a certain amount of depression does occur in the case of young infants when we have several days of excessive summer heat. This increases perspiration and consequently causes thirst. Thirst, even in nursing infants, may lead to their taking too much food; and still more is it likely in the case of hand-fed children, where the supply of food is not limited. Again, heat may depress the nervous system and in this way interfere with digestion. Often we see a combination of all these factors. They certainly are sufficient to create a strong predisposition to a diarrhoeal attack.

**Summary of Etiology.**—The predisposition to diarrhoeal diseases is furnished by age (under two years), enfeebled constitution, bad hygienic surroundings, and a chronic disorder of digestion depending upon improper methods of feeding or nursing and the habitual use of improper foods.

Their chief exciting cause is something to the development of which two things have a fixed and constant relation,—viz., a certain degree of atmospheric heat and the practice of artificial feeding. Both these conditions are necessary. We believe the chief causative factor to be bacteria, and that these act in most cases by inducing changes in the food.

---

## II. THE RELATION OF BACTERIA TO DIARRHOEAL DISEASES.

### I. THE EVIDENCE THAT THESE DISEASES DEPEND UPON BACTERIA AS THEIR PRINCIPAL EXCITING CAUSE.

This is in part deducible from a study of their etiology, partly from their clinical history, partly from pathological findings, and partly from analogy; but little, unfortunately, from purely experimental sources.

These diseases begin to prevail epidemically when a certain atmospheric temperature is reached,—an average of 58° to 60° F., there being with temperature below this point not many more deaths than in winter. This temperature, then, is an essential causative factor, and is that at which putrefactive processes first become very active.

The diarrhoeal diseases are frequent and severe where other conditions favorable to bacterial growth, besides temperature, are present to a marked degree. They are found in the crowded tenement districts of the large cities, and in those places where the least attention is paid to cleanliness in milk foods, bottles, etc.

The prevalence of diarrhoea is coincident with the extent to which artificial feeding is carried on. Cow's milk is the food, to a greater or less degree, of all hand-fed infants, and it is an excellent culture medium for bacteria. By the present methods of handling cow's milk bacteria in the air find ready access to it, and living bacteria are, furthermore, always found

in milk, in summer in great numbers. Finally, at this season milk is often allowed to remain for hours at a temperature high enough for very active bacterial development.

Abundant experience has shown that impure milk will produce diarrhœal diseases, and that these prevail among infants pretty much in the proportion in which such milk constitutes their food.

They are not frequent where infants get a food free from germs, such as breast-milk, even though the other conditions, hygienic and atmospheric, may be very unfavorable.

They are not frequent among infants in the country, who get for their food fresh cow's milk, nor among city children in winter,—which shows conclusively that it is not the chemical composition of cow's milk that is the difficulty.

Clinically we are brought face to face with a group of symptoms which admit of no other satisfactory explanation, in the light of our present knowledge, than that they are of toxic origin from the absorption from the intestines of ptomaines produced by bacteria. These symptoms are—high temperatures which autopsies show are not inflammatory; profound nervous symptoms, such as great prostration, delirium, coma, or convulsions, without, in most of the cases, any demonstrable changes in the brain, and often subsiding when the intestinal contents have been discharged; and, finally, the great evolution of offensive intestinal gases seen in nearly all acute cases.

It has been established that at least two forms of bacteria are capable of producing lesions in the intestines bearing some resemblance to those found in certain inflammatory diarrhœas of infancy,—viz., the bacillus of typhoid fever and the bacillus tuberculosis. Further, it is established that epidemic cholera, a disease most closely allied clinically with cholera infantum, is due to the comma bacillus.

Brieger has pointed out the poisonous nature of many of the ptomaines, which has been confirmed by the subsequent investigations of Boucharde and others. Vaughan<sup>13</sup> has isolated from milk, which had been fed to a child in whom cholera infantum developed, a ptomaine which produced vomiting and purging in a cat to which it was administered. He further found a similar substance in ice-cream which had produced in adults poisonous symptoms, prominent among which were vomiting and purging.

Other isolated instances are recorded in which poisonous ptomaines producing diarrhœa have been demonstrated in milk.<sup>14</sup> There is yet wanting sufficient evidence to establish the fact that any form of bacteria thus far investigated bears a causative relation to any of the varieties of diarrhœal disease in children.

We do not know yet what the bacteria are which produce these diseases; but the foregoing points taken together form a chain of evidence establishing, almost beyond the possibility of doubt, the fact that bacteria play a very important part in the production of a very large proportion of them.

We do not know positively by what avenue the bacteria gain access to

the body, but the very close connection with the use of milk foods leads to the presumption that in the vast majority of cases it is through the food; although it is quite possible that in some cases the germs may be in the air, or even in the water.

## II. THE RELATION OF BACTERIA TO THE OTHER ETIOLOGICAL FACTORS.

The study of intestinal bacteriology has already advanced far enough to establish the fact that micro-organisms are always present in the intestinal canal after the first twenty-four hours of life. Although the number present is very large, yet the varieties are few,—Escherich<sup>15</sup> having found but two species constantly occurring in the intestines of healthy nursing infants. This small number is explained by him by the conditions there existing,—viz., the exclusive diet, the absence of oxygen, and the fact that casein and milk-sugar are so rapidly and so completely absorbed. It is not due to the presence of bile, since bile is not an intestinal antiseptic, as we were formerly taught, Booker and others having found that almost all intestinal bacteria grow well in a ten-per-cent. solution of bile. Its influence in diminishing intestinal putrefaction, then, must be due to its action in digestion and absorption. When bile is absent both these processes are imperfect and decomposition takes place in the unabsorbed residue.

The acidity of the stomach does not protect the intestines against the entrance of living bacteria. Miller<sup>16</sup> found that an acidity of 0.16 per cent. of hydrochloric acid was required to stop the growth of bacteria, and the acidity of the infant's stomach has been shown by the best experiments to be considerably less than this. Van Puteren<sup>17</sup> found in observations on eight infants that it was only 0.08 per cent. Finally, MacFadyen<sup>18</sup> demonstrated that in dogs, the acidity of whose stomachs is well known to be great, almost any variety of bacteria could be made to pass the stomach, provided large draughts of water were given at the same time.

It does not seem likely that the varieties which are constantly present kill out the others introduced and in this way stand guard to protect the intestine, although this view has been suggested.

Healthy digestion and perfect absorption are the great obstacles to the development of new varieties.

Although other bacteria are being introduced all the time, they fail to develop, because their number is small or the resistance of the tissues great or they do not find proper food.

This normal balance may be destroyed, first, by increasing the amount of unabsorbed residue in the intestines. (1) This may be because too much food has been taken, all the other conditions being normal. (2) The food may be proper as to quantity and character, but there is failure of the digestive powers. This may be habitual, from constitutional debility; it may be transient and sudden, as in the invasion of any acute disease; it may be the result of many nervous influences, of which the depression



resulting from high atmospheric temperatures is certainly one. (3) Food is given which is so improper for infantile digestion that it is acted on but very slightly or not at all by the stomach, and passes almost unchanged into the intestines.

In all these cases the final result is the same,—*i.e.*, there exist in the intestine undigested or partially-digested masses, which at the temperature of the body readily undergo putrefaction, they furnishing a soil in which many new forms of bacteria may thrive. If the active cause is only a transient one, as soon as these decomposing masses have been eliminated, proper feeding and the re-establishment of healthy digestion soon restore normal conditions.

If the cause continues operative, anatomical changes follow, which will be detailed hereafter.

The normal balance may be destroyed, in the second place, by the introduction of pathogenic germs. The effect of these germs will depend (1) upon their nature, (2) upon their number, (3) upon the vulnerability of the tissues. Regarding the nature of the germs which produce the injurious effects we know next to nothing: there are probably many varieties.

The toxic dose of bacteria must vary with each individual, and in the same individual it must be different under different circumstances. The number which can be taken into the intestine of a strong infant with healthy organs without any serious consequences is undoubtedly pretty large. A very much smaller number in a delicate infant of feeble constitution is sufficient to set up the most active decomposition, with very serious results.

The most important condition, however, is that of the digestive organs. While healthy organs are able to withstand the action of bacteria unless their number is very great, a mild intestinal catarrh, the result of habitual indigestion, and the presence of undigested materials, furnish the conditions the most favorable for their development. At such a time the entrance of a comparatively small number of bacteria may prove dangerous.

This subject of vulnerability of the tissues and dosage, if we may use the term, of bacteria throws a good deal of light upon certain commonly-observed facts in etiology,—as, for example, the immunity of children who have passed their second year. We may not explain this by their diet, for milk, and just as bad milk, is often given in the third year as in the first two years, yet without producing the same injurious results. We do not know of any anatomical or physiological differences in the intestinal tract in later childhood sufficient to explain this immunity, and we must conclude that, notwithstanding the continued introduction of bacteria in considerable numbers, comparative immunity exists because the intestinal tract almost ceases to be a vulnerable point for bacterial attack.

Children in the country and of the better classes suffer less, because their food contains fewer germs and their resistance is much greater.

Breast-fed children escape, for the reason that their digestive organs are

usually healthy, and their food free from germs. Hand-fed children suffer most: first, because they are almost always over-fed; secondly, because a large number of them suffer almost all the time from a mild type of intestinal catarrh; and, thirdly, because their food in summer contains germs in large numbers. In the absence of the third condition, the two others are not usually potent enough to produce serious consequences. But the union of all three gives us our worst cases.

It is possible for ptomaines to be formed in the food outside the body and for symptoms to follow the ingestion of such food almost immediately, apart from any previously abnormal condition of the digestive tract, they requiring only absorption. Cases are occasionally met which present a clinical history suggesting such an explanation. But in the majority of cases we cannot tell whether the poisonous ptomaines are elaborated outside or inside the body or both, and really it makes but little difference.

### III. THE RELATION OF BACTERIA TO THE LESIONS.

The continued presence of undigested or indigestible food in the intestines may produce effects mechanically, but more commonly, probably, by its decomposition by the agency of bacteria. These produce irritating acids and ptomaines, and gradually there is set up a low grade of intestinal catarrh. As a result of this catarrh, mucus and serum are added to the intestinal contents, and possibly also oxygen from the hyperæmia, all of these new conditions tending to increased activity of bacterial growth, which in turn aggravates the lesions. The lesions diminish or prevent the secretion of proper digestive fluids, and impaired power of digestion adds a new impulse to the decomposition. This condition may have been weeks or even months in developing, but when it exists it is easy to understand how pathogenic germs may develop with great rapidity which under normal conditions could not find a foothold.

Dr. T. M. Prudden<sup>19</sup> has shown, in his experiments upon rabbits with the streptococcus of diphtheria, that as much as a teaspoonful of a pure culture could be injected into the trachea of a healthy rabbit without producing pneumonia. The germs were found to have disappeared entirely when the animal was killed a few days later. If, however, before the introduction of the streptococci a certain amount of inflammation was excited by the inhalation of some irritant, as ammonia, the most intense pneumonia developed, and large colonies of streptococci were found in the exudation of the air-vesicles.

The law which these experiments illustrate is one of pretty wide application in bacteriology, and it has an important bearing upon the prevention of diarrhoeal disease, under which head it will be referred to more fully.

That the symptoms of a mild intestinal disorder precede for some days the severe forms of diarrhoea is a matter of common clinical observation, and the experiments above referred to show how this fact is to be explained.

Exactly how the bacteria produce the lesions we cannot say positively.

At autopsies, where these are made within two or three hours after death, we find bacteria, as a rule, only upon the surface and in the superficial layers of the mucous membrane, even in cases where the lesions are the most severe; although they penetrate the tissues pretty rapidly after death, and at the end of eighteen to twenty-four hours may be found to have penetrated to the submucosa. In the worst cases the number of bacteria in the tissues is, as a rule, surprisingly few. Nor have I ever been able to demonstrate them in hardened specimens either of the mesenteric glands or of the kidneys: this might, however, possibly be done by cultures from fresh specimens.

The inference, however, is that it is not the bacteria directly which produce the lesions, but their ptomaines, and, further, that the action of the latter is principally upon the blood-vessels. That the lesion produced is in one case a catarrhal inflammation, in another croupous, in a third follicular (inflammation of the lymph-nodules), probably depends upon a difference in the form of bacteria.

In conclusion, we accept the doctrine that as an exciting cause in the intestinal disorders of infancy we are concerned most of all with the development of abnormal bacteria, but that before this takes place there is in almost all cases a failure of complete digestion and perfect absorption.

It seems to be possible for bacteria to be introduced in sufficient numbers to overpower even healthy digestive organs.

The anatomical changes are to be looked upon as secondary, and due to the continuance of the putrefactive processes.

---

### III. PATHOLOGICAL ANATOMY.

In this section I shall confine myself almost entirely to a record of my personal observations.

I have made microscopical examinations of the intestines in one hundred and nine cases of infants and young children. Of this number seventy were cases of primary intestinal disease, the patients dying either from these diseases or from their complications. The remaining thirty-nine cases were divided as follows:

Pneumonia . . . . .	14
Diphtheria . . . . .	9
Tuberculosis . . . . .	5
Athrepsia . . . . .	6
Purpura . . . . .	2
Empyema . . . . .	1
Malignant pustule . . . . .	1
Fracture of the skull . . . . .	1

These have been used principally as control cases, although in several of them interesting intestinal lesions of the milder types have been very often seen. In others were observed the results of diseases which had existed several months before. Of the autopsies upon the intestinal cases the greater part were taken consecutively in the New York Infant Asylum, where with very few exceptions every fatal case comes to the autopsy-table.<sup>1</sup> This fact adds some value to the observations from a statistical point of view. The cases of miscellaneous diseases were taken chiefly at random.

A few points in the anatomy of the normal intestine must be mentioned in order to an understanding of its pathological anatomy.

The intestinal wall is made up of four coats: the serous or peritoneal; the muscular, which is arranged in two layers, an internal circular and an external longitudinal; the submucous or cellular; and the mucous membrane. The submucous coat is made up of connective tissue, and contains the net-work of blood-vessels and lymph-channels. Between this and the mucosa is a thin layer of muscle-fibres, the muscularis mucosa, which also consists of two laminae, the inner, circular one giving off numerous processes, which run between the tubular glands of Lieberkühn towards the surface of the mucosa. In the small intestine some of these enter the villi.

The mucosa is made up of tubular glands, or follicles of Lieberkühn, which are lined with cylindrical epithelium. Among these epithelial cells, irregularly placed, are certain large cells which are usually open towards the surface, their widest portion. These are the goblet- or beaker-cells, and it is now generally admitted that their function is the secretion of mucus. They are very much more numerous in the large than in the small intestine. Under the microscope they have a cloudy appearance, as their contents do not stain clearly. The tubular glands are connected with one another at their orifices by a continuous layer of cylindrical epithelium.

Between these glands the mucosa is made up almost entirely of lymphoid tissue, consisting of a reticulum, with a pretty abundant sprinkling of small round cells occupying the spaces. Scattered here and there are seen aggregations of lymphoid cells, forming the lymph-nodules or solitary follicles. Their internal structure is the same as that of similar nodules elsewhere in the body.

They are situated partly in the mucosa and partly in the submucosa. Those in the small intestine are almost entirely in the mucosa. They have no investing capsule, although in the submucosa a sort of limiting membrane is made up by the condensed connective tissue. In the mucosa they are covered at their summits by the epithelium only; laterally they are

---

<sup>1</sup> For valuable assistance in this portion of the work I wish here to express my indebtedness to Dr. T. Mitchell Prudden, Director of the Laboratory of the College of Physicians and Surgeons, and to Dr. John S. Thacher, Director of the Laboratory of the New York Polyclinic. I am indebted to Dr. Robert Milbank, my colleague at the Infant Asylum, for allowing me to make use of the cases in his service in the summer of 1888.

partly limited by the tubular glands, but the cells infiltrate more or less the adenoid tissue overlying the mass of the nodule.

In the small intestine the solitary lymph-nodules are scarcely visible to the naked eye unless they are enlarged. In the colon in a normal state they are gray, almost flat, and present very often a central dot, which may be pigmentation or simply a slight depression. This was once regarded as the opening of an excretory duct.

The great frequency with which these lymph-nodules are enlarged in infants has led some to believe that these are always round and projecting. The routine examination of the intestines in all autopsies in children will quickly show that this is not the case. Peyer's patches are simply aggregations of a number of these lymph-nodules.

In addition to the larger nodules easily recognized under the microscope, there are seen in infants a considerable number of small collections of a few dozens of round cells, in the upper part of the submucosa, which might be mistaken for inflammatory products.

The structure of the villi and the distribution of blood-vessels present no peculiarities in early life.

The principal points of difference to be kept in mind in relation to pathology are the abundance of the lymph-nodules and smaller lymphoid masses and the richness of the lymphatic plexuses.

#### EXAMINATION OF THE INTESTINES.

All autopsies upon cases of intestinal disease should be made as early as possible. For microscopical study this is indispensable, but the gross changes are not often materially altered by a delay of twenty-four hours. The common practice of washing the intestines by allowing a stream of water to flow through them before they are opened is objectionable, since in this way there is no opportunity to study the contents of the bowel, a matter sometimes of much interest.

For microscopical work the part of intestine to be examined should be laid open carefully by scissors, and pieces cut off from one to two inches long; these should not be washed at all if the part is to be examined for bacteria, otherwise they may be waved back and forth a few times in a saline solution. They should be gently stretched enough to obliterate the deep folds in the mucosa if any exist, and dropped into a flat dish containing ninety-five-per-cent. alcohol. The specimen stiffens in a few minutes: the borders which have been handled can then be cut away and the specimens put into jars. For hardening, ninety-five-per-cent. alcohol should be continued if we wish to cut them in a few days; if they are to remain long, a weaker solution—eighty-per-cent.—is better, or they may become too hard and brittle. By using the strong alcohol and changing it once, specimens may be cut in four or five days. They are then to be embedded in celloidin in the usual manner, double-stained with hæmatoxylin and eosine, and mounted in balsam.

The rough handling which intestines have generally received at autopsy is responsible for some of the erroneous notions which exist concerning their pathology.

**Post-Mortem Changes.**—These occur probably more readily in the intestines than in any other mucous membrane in the body. Unless they have been carefully studied by themselves, they lead to continued confusion respecting the interpretation of the microscopical appearances.

The post-mortem changes in the mucous membrane depend upon the time that has elapsed after death before the autopsy is made, upon the nature of the intestinal contents, upon their reaction, upon the weather, upon whether the intestine is contracted or distended, upon the region from which the specimen is taken, and upon the care with which the organs are handled, as well as upon disease. Woodward<sup>20</sup> states that any observations upon the epithelium must be made within six hours to be significant, and that loss of epithelium after that time is not to be looked upon as evidence of disease. With this Nothnagel<sup>21</sup> has concurred, and since his time Baginsky.<sup>4</sup> My own experience leads me to practically the same conclusion, taking, however, the other circumstances mentioned as modifying influences. If the intestines are filled with thin fluid matters, the changes take place very much more rapidly than when they are empty or simply coated with mucus. The changes are more rapid if the contents are alkaline than if they are acid; more rapid in hot weather than in cold, unless all bodies are put immediately upon ice. Contracted portions of intestine are always better preserved than those that are distended. In fact, one must be very cautious in drawing any conclusions respecting the appearances of intestine which has been stretched by gaseous distention, since by this all the structures are much changed.

So far as region is concerned, in over eighty examinations in which the point was noted, the epithelium was lost in the jejunum in forty per cent. of the cases, in the ileum in sixty per cent., in the colon in sixty-four per cent. The difference seems to depend largely upon the difference in contents.

Careful handling makes a great difference. Diseased epithelium certainly loosens very much more readily than healthy epithelium, and even six hours after death its absence under circumstances favorable to maceration and decomposition is not always evidence that it was ante-mortem. On the other hand, I have seen epithelium almost perfect in the ileum of a case in which the autopsy was made sixty-eight hours after death.

Loosening and falling out of the tubular glands or follicles of Lieberkühn was seen to a greater or less degree in almost all specimens from autopsies over twenty-four hours old. Under favorable circumstances this may take place even in twelve hours. It is more rarely seen in contracted, but almost always in dilated, portions of the gut. This appearance, when it is general, is not unlike that seen in chronic inflammation with atrophy and disappearance of these structures. The sockets or beds from which the gland has fallen out are usually clearly defined in the former case. (See Fig. 1.)

Disappearance of these glands may lead to a great apparent increase in the number of cells in the mucosa.

The solitary lymph-nodules when enlarged often present, both to the naked eye and under the microscope, appearances entirely due to post-mortem change, which are almost identical with those seen in commencing ulceration. This consists in loss of their epithelial covering, and erosion of their summits. (See Photos. I. and II.\* and Fig. 1.) This is common in autopsies which are more than twenty-four hours old.

In the small intestine the villi, when deprived of their epithelium, frequently fall over upon the surface of the mucous membrane, giving an appearance closely resembling that of a thick layer of round cells.

In autopsies made from thirty-six to sixty hours or more after death, the epithelium and other cells have often become so altered as to stain slowly, indistinctly, or not at all.

I have made some experiments upon healthy intestines, studying the changes of decomposition under different conditions, and have seen produced from this cause appearances which were scarcely distinguishable from those seen in many cases of acute inflammation of the intestine. The greatest discretion, then, must be exercised in drawing conclusions from these appearances, and all the modifying conditions must be taken into consideration.

**Bacteria.**—With reference to this subject we must be still more cautious in drawing any conclusions. Under the most favorable circumstances I have found experimentally that bacteria would penetrate a considerable distance into the mucosa in fourteen hours, while in twenty-six hours they were diffusely scattered through the whole mucosa, and in forty hours they were found everywhere in great numbers.

#### PATHOLOGICAL CLASSIFICATION.

As intimated in the introduction, it is not advisable in intestinal diseases to endeavor to make a clinical and a pathological classification exactly coincide. Such an attempt would lead rather to confusion and often to needless repetition. The subjoined classification is as simple a grouping of the cases as seems to be possible. There are included here only the seventy fatal cases of diarrhœal disease in which the exact nature of the changes was determined microscopically.

I.† *Acute desquamative catarrh*, embracing the acute cases with no lesions except loss of the superficial epithelial layer: twenty-two cases.

---

\* These are reproductions from photographs taken for me by O. G. Mason, Photographic Department of Bellevue Hospital.

† The propriety of separating classes I. and II. may be questioned. We cannot be sure that the process in I. is not the first stage of II. Still, the fact that in so large a number of cases we find nothing but a loss of epithelium is a striking one, and, taken with the clinical history, seems to make it desirable to separate them from the cases where other lesions are found.

II. *Acute catarrhal inflammation*, other lesions than the loss of epithelium being present: sixteen cases.

III. *Acute inflammation of the lymph-nodules, with ulceration (follicular ulceration)*: twenty cases.

IV. *Acute croupous inflammation*: nine cases.

V. *Chronic inflammation*: three cases.

I. **Acute Desquamative Catarrh**, or acute cases in which the only essential change is a loss of the superficial epithelium. Of these twenty-two cases, thirteen were children previously suffering from athrepsia; four were clinically cases of genuine cholera infantum; two were cases of acute dyspeptic catarrh occurring during convalescence in children who had suffered previously from acute catarrhal inflammation of the intestine; two were cases of rather marked gastritis, but lesions very much less marked in the intestine; and one was an acute dyspeptic diarrhoea in a six-weeks infant. It is to be regretted that only a small proportion of these autopsies were made within the six-hour limit previously laid down, so that we cannot affirm that the loss of epithelium was not a post-mortem change. It was found, however, absent, or nearly so, in cases examined as early as three hours after death, and the probabilities are in favor of the change being ante-mortem in most of the cases.

In one case in which marked diarrhoeal symptoms had existed during life, complicating pneumonia, I obtained an examination of the intestines three hours after death. In this case the epithelium was almost perfect.

Desquamation of the superficial epithelium is not, therefore, a constant accompaniment of acute diarrhoea, but it probably occurs to a greater or less extent in most of the cases severe enough to cause death.

A noticeable feature is the large proportion of cases of athrepsia. It is surprising that these cases succumb so readily. In nearly all the symptoms were only those of an ordinary acute dyspeptic diarrhoea of no great severity. In these, as well as in the cases of cholera infantum, it is evident that the lesions found are not sufficient to explain the symptoms during life. The majority of these cases are of from two to four days' duration.

*Gross Appearances.*—In the cases which have presented clinically the symptoms of an acute dyspeptic diarrhoea, the small intestine is apt to be distended with gas, and to contain at its lower portion undigested food and thin yellow or dirty-green fluid or semi-fluid materials, often quite offensive; the large intestine is frequently empty, but may contain matters similar to those seen in the small intestine, mixed with mucus. Except for the contents, the appearance of the intestine in many of the cases does not differ essentially from that seen after death from any other disease. In athrepsia cases the effects of the long antecedent chronic dyspeptic catarrh are often seen in the shape of an enlargement of the solitary lymph-nodules of the colon, or more rarely pigmentation. There are irregular areas of congestion, but so are there in almost every intestine seen post mortem.

In the cases of cholera infantum the appearances are more characteristic.



The small intestine is apt to be distended with gas, as is also the transverse colon; the rest of the large intestine is generally contracted and nearly empty.

The intestinal contents consist quite uniformly of a fluid material of a grayish-white color and about the consistency of thin gruel. It has a mawkish odor, but not usually a very offensive one.

The mucous membrane of both small and large intestines has most commonly a pale, "washed-out" appearance. Less frequently this is seen in the small intestine only, while there are small areas of slight congestion in the colon.

The above appearances are those most commonly met with, and the only ones which are characteristic of the disease.

Since, however, choleric diarrhoea is occasionally engrafted upon another pathological process in the intestines, we may find widely-varying appearances, depending upon the antecedent disorder, such as catarrhal inflammation of varying degrees, and not very infrequently old ulcerations.

*Microscopical Appearances.*—These, like the gross appearances, are usually disappointing. The changes are generally wide-spread, and frequently involve almost the whole alimentary tract. The small intestine usually suffers as much as the colon, and in a small proportion of the cases the major part of the lesion is in the small intestine.

In the most recent autopsies we find the superficial epithelium for the most part gone. Here and there a few cells may be seen *in situ*. The cells lining the tubular glands at their mouths have likewise largely disappeared. In the fundi they are usually present. The nuclei of the cells which remain stain normally, but the protoplasm is frequently cloudy and finely granular.

I have stained quite a number of these specimens for bacteria. The rule is, in examinations made early, to find them upon the surface only. As we have previously seen, the position in which they are found after five or six hours is of no positive significance. In the single case of cholera infantum in which I got an early autopsy I found the whole mucosa filled in places with small diplococci. A single case admits of no deductions.

**II. Acute Catarrhal Inflammation**, with lesions other than a loss of epithelium (sixteen cases, or twenty-three per cent. of the fatal cases). These cases are distinguished clinically from the foregoing by their longer course, the average duration being about a week, and usually by a continuous elevation of temperature,—101° to 104° F. In a few of these cases there was a slower course, with little or no fever after the onset. This course was more often seen in children who had previously suffered from athrepsia. The relative frequency of these cases is manifestly not represented by the number of autopsies, since the largest proportion of them terminate in recovery.

*Gross Appearances.*—As in all other varieties of intestinal inflammation, the lower ileum and the colon are the most frequently affected, but

not so exclusively here. It is not uncommon to find changes of quite a marked character through a greater part of the small intestine. This is more frequently seen in the cases of short duration, where they are sometimes more marked than in the colon. In the cases of longer duration it is the colon which shows the most extensive changes, with few exceptions. It is extremely rare to find the small intestine the exclusive seat of disease.

The intestinal contents are usually green in color and thin. The mucous membrane is often coated with tenacious mucus. The small intestine is commonly distended with gas, the large intestine nearly empty, excepting the transverse colon, which is likewise distended. The mucous membrane is somewhat swollen, but this is not a marked feature. In the small intestine there are occasionally seen swelling and œdema of the villi so that they project abnormally and give a plush-like appearance; with a lens they look somewhat club-shaped. Congestion is a constant feature. It may be arborescent, following the course of the veins, which are seen to be greatly engorged: this occurs usually in the small intestine, and is scarcely pathological. It may be simply upon the folds into which the mucous membrane is thrown. It may be about the solitary lymph-nodules, forming a little red zone about the follicle; or it may be so intense that the whole intestine for a considerable space is of a uniform deep-red color. The last appearance is usually seen in scattered patches a few inches long, the intervening intestine often being nearly normal in color. These patches are very frequent in the cæcum and sigmoid flexure. Small hemorrhagic spots are often seen here and there widely scattered. In most of the cases there is no real thickening of the intestinal wall, but this is often simulated by the contraction of the muscular coats. In the few cases of great severity there is marked thickening and a general resemblance to the appearances of croupous inflammation: the distinction from the latter can usually be made by the microscope only.

The lymph-nodules (solitary follicles) may be normal in size, but they are more frequently swollen throughout the colon. They project above the mucous membrane, and appear about the size of a mustard-seed, sometimes larger. In the small intestine this enlargement is much less frequently seen, although when enlarged they project much more than in the colon.

Peyer's patches are swollen in but a very small proportion of the cases; when this swelling is recent, there is usually associated quite marked congestion of the patch. This is, however, not common. The swelling of the solitary lymph-nodules and Peyer's patches found at autopsy may depend not upon the final attack of diarrhœa, but upon antecedent disease. The existence of pigmentation favors the latter explanation, while acute congestion points to recent disease. In many cases it is impossible to say positively whether the swelling is recent or old.

*Microscopical Appearances.*—As has been previously stated, nothing can be affirmed concerning the condition of the epithelium unless the autopsies have been made within six hours (sooner in very hot weather), and

the intestines carefully handled. (See paragraph upon post-mortem changes.) There is usually loss of the superficial epithelium and of that lining the tubular glands at their orifices, similar to what has been described in the first class of cases. Upon the surface of the mucosa and within the tubular glands fine granular matter is seen from the broken-down epithelium. The goblet-cells are distended with mucus, and do not stain clearly. The lumen of the tubular glands is narrowed from pressure due to the swelling of the adenoid tissue which separates them, which is partly from œdema and partly from cell-infiltration. (See Fig. 5.) Entire tubular glands may loosen and fall out, particularly where the intestine has been distended. In the small intestine the villi project normally in most cases, unless the part examined has been stretched by gaseous distention, when they may lie almost flat and simulate closely a very thick layer of new round cells. There is in most cases very little epithelium remaining where the other changes are marked.

It sometimes happens that a thick layer of mucus and round cells adheres closely to the surface, resembling very much a layer of pseudo-membrane. (See Fig. 6.) Beneath this we may find in places nearly normal epithelium.

In the milder forms of the lesion the amount of infiltration of round cells is not great, and is usually limited to the mucosa. It is more marked in the superficial than in the deeper parts: the extent depends principally upon the duration of the process. In the very severe cases we find a dense infiltration of the mucosa and of the submucosa also, in places quite to the muscular coat. These cases closely resemble those of the croupous variety, lacking only the pseudo-membrane.

Occasionally in the severe catarrhal variety, but more frequently in the croupous, there are seen superficial erosions of the mucosa or catarrhal ulcers. These do not appear at all to the naked eye. There is a complete destruction of more or less of the thickness of the mucosa, and only the fundi of the tubular glands may remain. It rarely goes to the muscularis mucosæ. These erosions never have sharp, well-defined borders, but the mucosa seems to be frayed out at these points. It appears to be a gradual process of softening, liquefaction, and removal of the superficial parts, adenoid tissue, and tubular glands, from the intensity of the inflammation. (See Fig. 7.)

The lymph-nodules are swollen to a greater or less degree, chiefly from an increase in the number of round cells in almost all the cases. In a number of the cases there have been seen at the centre of the nodules, mingled with the round lymphoid cells, collections of large epithelial cells of a peculiar character. They were seen both in recent cases and in those of longer standing. Sometimes there are catarrhal changes only, and sometimes the swelling of the lymph-nodules is the predominant feature of the lesion.

If the inflammatory process is sufficiently intense and prolonged, the lymph-nodules break down and ulcerate. These cases are considered else-

where in this article. The appearances in Peyer's patches are similar to those seen in the solitary lymph-nodules, but are much less marked, and frequently are absent altogether.

The blood-vessels take an active part in this process. The small veins and capillaries of the submucosa and mucosa are gorged with blood. In the patches of intense congestion these dilated vessels occupy a large part of the field. Small extravasations are very common, and occasionally larger ones are seen. There are no essential changes in the muscular coats.

This variety, except in its very severe form, which is not very common, presents no changes that cannot readily be repaired. New epithelium forms with very great facility. The infiltration of cells quickly disappears by absorption; the most persistent change is usually the swelling of the lymph-nodules, which lasts a long time, and this appears to be an important factor in the tendency to relapses and recurring attacks. The inflammatory process is not likely to go on to a chronic one unless there is a continuance of the exciting cause or the patient's constitution is a bad one. The very severe forms are almost certainly fatal.

**III. Inflammation of the Lymph-Nodules, with Ulceration (Follicular Ulceration).—**The cases of acute inflammation of the lymph-nodules which do not terminate in ulceration are included with those of catarrhal inflammation. They embrace a very large proportion of the cases which recover.

*Frequency.*—Excluding cases of tuberculosis of the intestines, I have met with follicular ulcers in twenty out of seventy fatal cases, or in nearly one-third of the autopsies upon infants dying from diarrhoeal diseases. They were never seen in cases which had lasted less than a week, and not commonly before the latter part of the second week, the average duration of the cases being about three weeks. In the fatal cases which had lasted more than two weeks the proportion of those with follicular ulceration was very much greater.

Clinically these cases run a slower course than the other varieties; the stomach is less frequently involved; there is not usually any marked continuous rise in temperature; blood in the stools is quite exceptional.

*Gross Appearances.—Situation.*—Of twenty cases in which follicular ulcers were found, they were in the small intestine alone in but two cases; in the small intestine and the colon in three cases; in the remainder they were situated only in the colon. When in the small intestine they were never seen except in the lower ileum. Occasionally ulceration is seen in one or two of the nodules of a Peyer's patch. Of those limited to the colon, there were ulcers in the whole extent in about one-half the cases; in the remainder they were in the lower half only. The deepest ulcers were seen in the order of frequency in the descending colon, the sigmoid flexure, the transverse colon, and the rectum. When ulcers were present throughout the colon, they were almost invariably smaller and more superficial in the upper than in the lower half.

PHOTO. I.

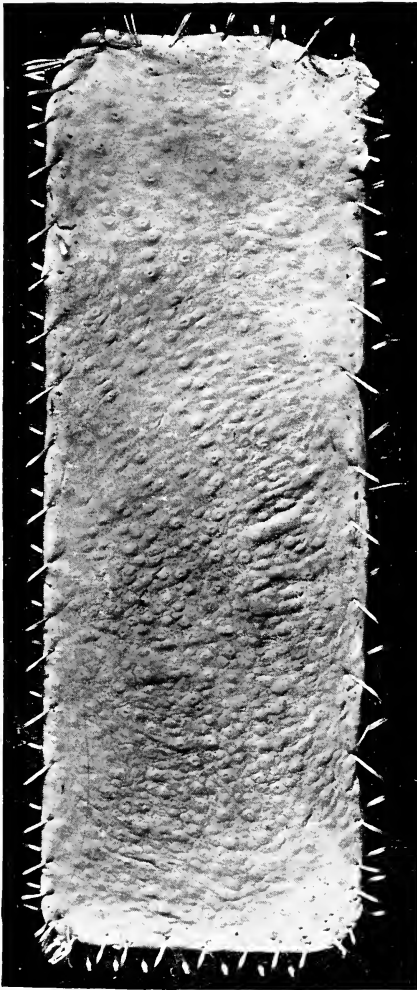

HYPERPLASIA OF THE LYMPH-NODULES (SOLITARY FOLLICLES) OF THE COLON.

*History.*—Never any acute diarrhoea; until five months old almost all stools were green or brown, and contained mucus; general health was not affected. Died of acute pneumonia, at ten months, without intestinal symptoms.

*Autopsy.*—Twenty-six hours. Very marked swelling of solitary lymph-nodules throughout colon. The picture gives a very accurate idea of the appearance.

For microscopical examination, compare Fig. 1.



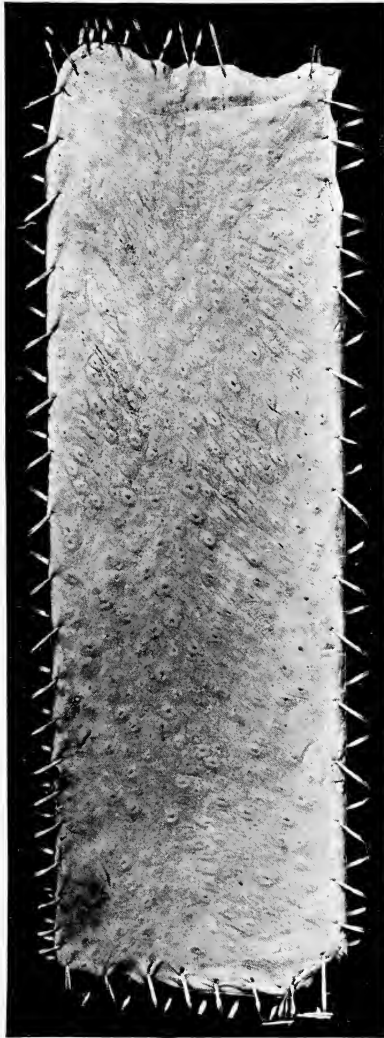

ENLARGED LYMPH-NODULES (SOLITARY FOLLICLES) OF THE COLON.

The lymph-nodules are very much enlarged and project. They show a central pit or depression large enough to admit the point of a small probe. This appearance is due almost entirely to post-mortem changes, but resembles closely the beginning of follicular ulcers.

*History.*—From same case as Photo. I.





РНОТО. III.

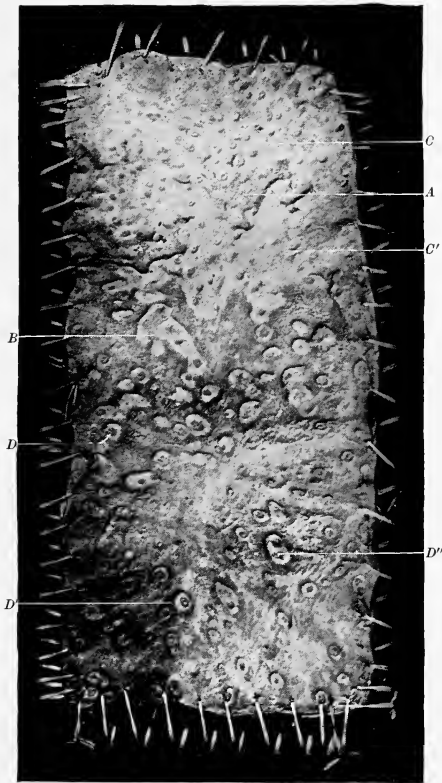

SUPERFICIAL ULCERS OF THE COLON.

*History.*—Nine months old; continuous intestinal symptoms fifteen days; temperature, 101° to 102° F.; stools green, yellow, mucous, and offensive.

*Autopsy.*—Twenty-five hours. Superficial ulcers throughout colon; no deep ulcers. Photo. is from descending colon. At the middle and lower portions of the specimen are small circular ulcers, as at *D* and *D'*. At the centre of each one a small projecting nodule is seen,—the solitary follicle. At *D''* two single ulcers have coalesced; at *B* five have coalesced, forming a shallow, irregular ulcer. The upper part of the specimen shows a very large ulcer, *C, C'*, about one and a half inches long and the width of the gut, evidently from a coalescence of many small ones. At *A* only is a small island of the mucosa seen. The small, granular bodies seen in the floor of the large ulcer are solitary lymph-nodules.

For microscopical appearances, compare Fig. 4.



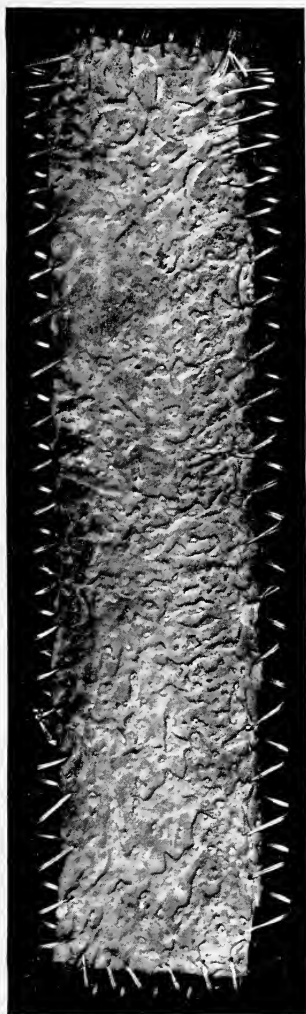

SUPERFICIAL ULCERS OF THE COLON.

*History.*—Delicate, hand-fed child, two months old; ill two weeks; temperature, 99° to 103° F.; no blood in stools.

*Autopsy.*—Twenty-four hours. Catarrhal inflammation in lower ileum, but no ulcers. Whole colon involved, and closely resembled specimen shown in photograph. It is filled with irregular, worm-eaten ulcers, none of which go deeper than the mucous membrane. At the bottom of the ulcers small, projecting, seed-like bodies are seen,—the solitary follicles. The formation of these ulcers is similar to that shown in Photo. III.



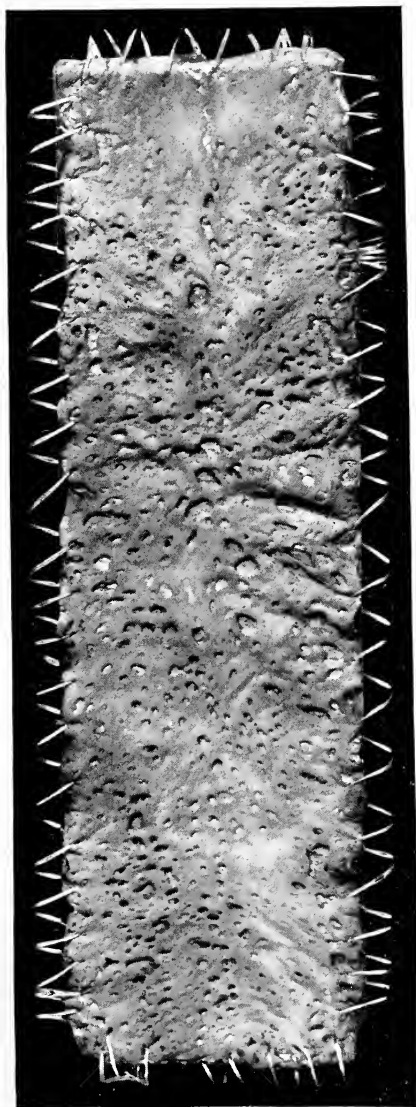

DEEP FOLLICULAR ULCERS OF THE COLON.

*History.*—Delicate child, fourteen months old; sick twelve days with acute intestinal symptoms; stools green, yellow, brown, and watery; no blood; temperature usually  $100^{\circ}$  to  $101^{\circ}$  F.

*Autopsy.*—Nineteen hours. Small intestine normal. Ulcers throughout colon,—in ascending small and circular, in transverse large and ragged. (See Photo. VI.) Specimen is from descending colon. It shows great numbers of small, round, punched-out ulcers, and a few larger ones about the middle from coalescence of several smaller ones. Nearly all the ulcers go to the muscular coat. For microscopical appearances, compare Fig. 3.



PHOTO. VI.

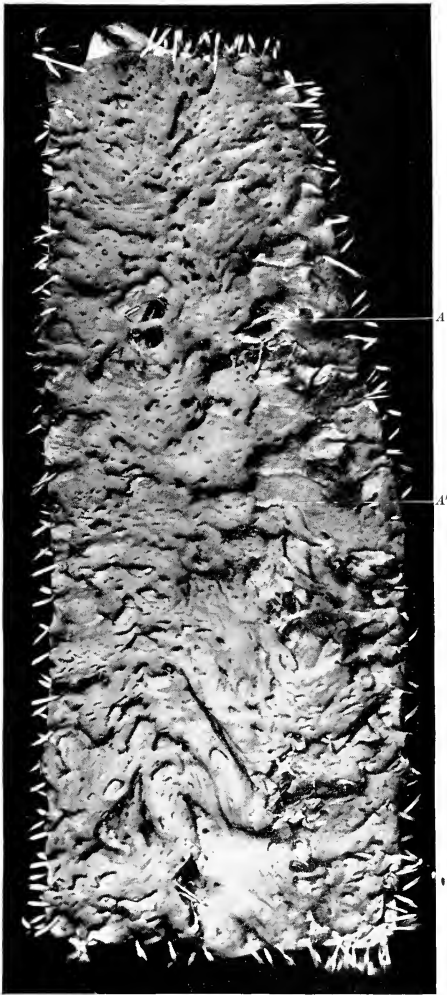

DEEP SLOUGHING ULCERS OF THE COLON.

From same case as Photo. V. The specimen here shown is the transverse colon. Large ragged ulcers are seen, with sloughs hanging from their surface. Where sloughs have separated, at *A* and *A'*, the transverse striations of the circular muscular coat are plainly seen. No perforations were present. Many small, circular ulcers are seen, resembling the smallest in Photo. V.

The microscope showed no fibrin in the exudation.





PHOTO. VII.

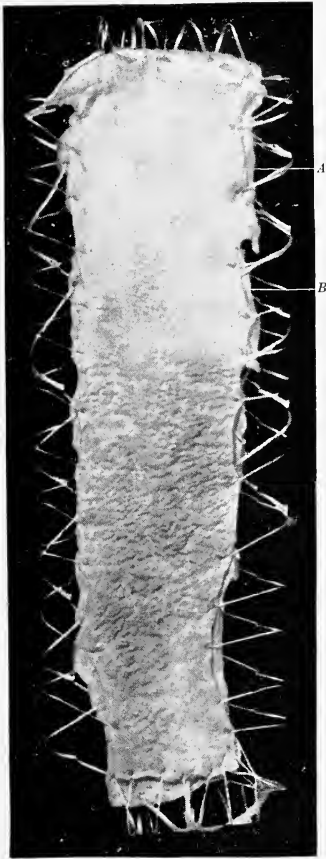

CROUPOUS INFLAMMATION OF THE ILEUM.

*History.*—Delicate child, eleven months old; mild diarrhoea two weeks; without fever; acute, severe symptoms twelve days; temperature,  $100^{\circ}$  to  $102.5^{\circ}$  F.; stools green, mucous, no blood.

*Autopsy.*—Twenty-three hours. Pulmonary tuberculosis. Lesions of intestine involve last foot of ileum and whole colon. The photograph is of a specimen from the lower ileum, and shows the abrupt termination of the lesion. The upper half of the specimen shows normal small intestine, Peyer's patches being seen at *A* and *B*. The lower half shows intense inflammatory changes. The intestine here was much thickened, intensely congested, and the surface had a rough, granular appearance, which is very well shown. No pseudo-membrane could be seen by the naked eye, but the microscope showed quite an abundant fibrinous layer upon the surface.

The microscopical appearances resembled those of Fig. 9.

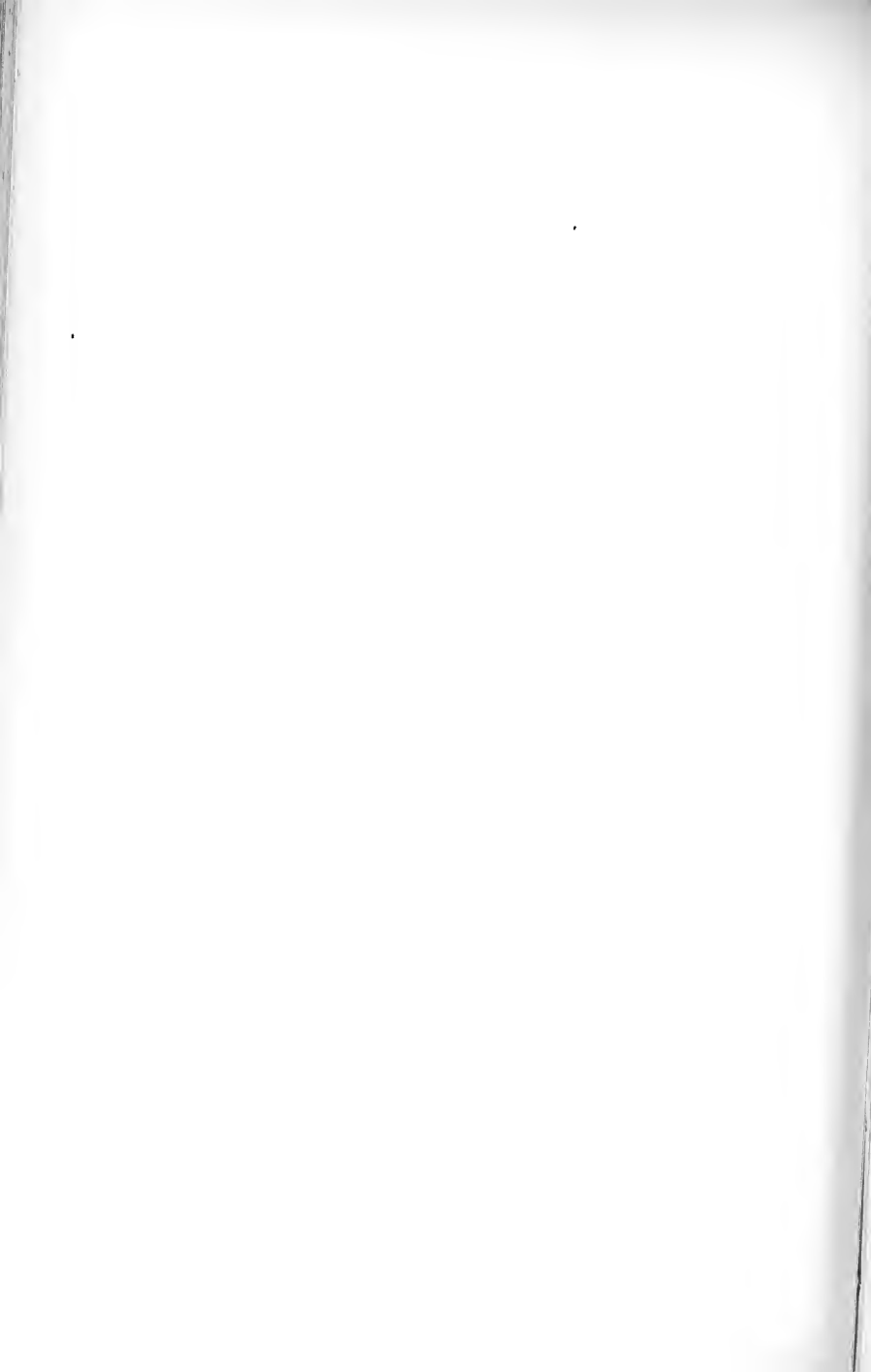

In the early stage these ulcers appear as tiny excavations at the summit of the prominent, projecting lymph-nodule (solitary follicle). This pit-like depression admits a fine probe. An exactly similar appearance is seen as a result of post-mortem changes in late autopsies in intestines where there has been nothing but hyperplasia of the nodules during life. (See Photos. I. and II.)

Later the whole nodule may be destroyed by ulceration, leaving a small deep ulcer about one-twelfth of an inch in diameter reaching into the sub-mucosa, its orifice being somewhat narrowed. Finally the ulcer extends in the submucosa, undermining the mucosa, which perishes as its nutrition is cut off. The usual size of the fully-formed ulcers is from one-twelfth to one-fourth of an inch. (See Photo. V.) By the coalescence of several of these in the manner just indicated, extensive ulcers, an inch or more in diameter, sometimes form. At the bottom of these larger ulcers the transverse striæ of the circular muscular coat are often plainly seen. (See Photo. VI.) It is exceedingly doubtful if perforation ever occurs in children from these ulcers. They have always overhanging, never bevelled, edges; the smaller ones are circular, and when closely set give the intestine a sieve-like appearance.

There is another variety of ulcers which differs in some marked features from those just described, but, as the starting-point seems to be the lymph-nodules (solitary follicles), I have included them with the follicular ulcers. I have seen but three well-marked cases.

These ulcers are superficial, never involving anything but the mucosa. They are at first small, and consist in a destruction of the mucosa immediately overlying the solitary follicle. When a little larger they are circular, and show in the centre a small, slightly-projecting, seed-like body, which is the follicle. Deep ulceration of the follicle does not occur, yet the ulcers readily coalesce and form large ones, sometimes two or three inches wide. But even these large ulcers do not go deeper than the mucosa. Ulcers identical with the smaller ones I have several times seen in the ascending colon when the common deep follicular ulcers existed in the lower portion of the large intestine. This fact and the entire absence of fibrin have led me to class these broad superficial ulcers with the follicular ones, rather than as croupous, although they have some features which suggest the latter origin.

Photo. V. is a typical illustration of the deep ulcers, both as to size and distribution. Photo. VI. shows large undermining ulcers which have had their beginning in deep follicular ulcers. More or less sloughing has occurred in this case. This is the only instance of extensive sloughing I have met with.

Both varieties of the superficial ulcers are shown in Photo. III.

In Photo. IV. the same process of superficial ulceration about the solitary lymph-follicles is seen, giving the mucous membrane a peculiar worm-eaten appearance. Closer examination shows in these specimens at the

centre or at the bottom of the ulcers a small seed-like body, which is the lymph-nodule.

*Microscopical Appearances.*—The lymph-nodules swell, principally from the accumulation within them of round cells. In some of the cases epithelioid cells are also seen. This swelling causes an elevation of the whole mucosa at the point where it overlies the nodule. (Figs. 1 and 2.) The next change usually is a destruction of the epithelial covering upon the summit of the nodule. Softening now begins at the apex and extends downward; the reticulum of the nodule breaking down, the round cells escape as pus into the intestine. (Fig. 2, *F*.) Sometimes softening begins at the centre of the nodule and rupture occurs. The destruction of the whole nodule leaves behind a tiny cavity, which is the follicular ulcer. At first the ulcers correspond in size to the nodule, but the adjacent tissue has meanwhile become infiltrated with a dense accumulation of round cells all about it, and this tissue becomes necrotic. The ulcer extends chiefly in the submucous coat. The overlying mucosa may slough or fall in upon the muscular layer. The ulcers have now quite a wide base and a constricted orifice. (Fig. 3, *F*.) These may extend to form large sloughs by the coalescence of small ulcers, but usually do not. The inflammatory process is never limited to the lymph-nodules; the amount of other change found depends upon the severity and very much upon the duration of the process. In cases dying after a week's or ten days' illness we usually find very little change in the mucosa, and in the submucosa sometimes none and sometimes a moderate infiltration of round cells, especially about the small veins. (Fig. 2, *V*, *V*.)

In those which have lasted three or four weeks we commonly find all the structures of the intestine in the neighborhood of the ulcers invaded. The mucosa is packed with new round cells, separating the tubular glands or in some cases destroying them; and all about the ulcer in the submucosa are cells in great numbers. They form the floor of the ulcer, and may spread along the lymph-spaces between the bundles of muscle-fibres and even infiltrate the muscular coat. (Fig. 3.) The ulcers stop almost invariably at the circular muscular coat. In only one case have I seen any destruction of this; perforation I have never seen.

The small follicular ulcers may readily be confounded with the simple post-mortem changes in the lymph-nodules. (Compare paragraph on post-mortem changes.)

The nature of the process by which the superficial ulcers (Photo. III.) are formed is not quite so clear. The inflammation starts evidently from lymph-nodules. There seems to be first a sloughing of the mucosa overlying the nodule, and the process extends not deeply into the nodule but laterally in the mucosa; the large ulcers form by a coalescence of the small circular ones, by a continuance of the same necrotic process. The submucosa beneath these ulcers is densely packed with round cells, but never seems to be involved in the destructive process. (See Fig. 4.) These cases

FIG. 1.

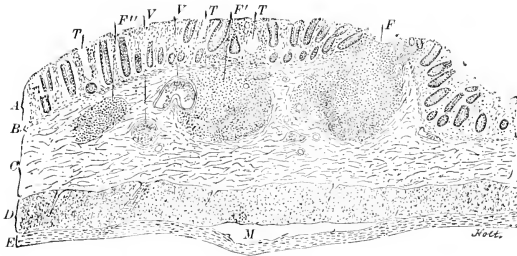

CHRONIC HYPERPLASIA OF LYMPH-NODULES OF COLON.

*History.*—Well-nourished infant, ten months old; died of acute pneumonia without intestinal complications; chronic dyspeptic catarrh from birth till five months old; nursed by mother; stools became normal without treatment, and were so till death.

*Autopsy.*—Twenty-six hours. Small intestine normal; whole colon showed marked enlargement of lymph-nodules; gross appearances shown in Photos. I. and II.

Three lymph-nodules (solitary follicles), *F*, *F'*, and *F''*, are shown. They are alike in size and situation; the difference in appearance depends on the direction of the section. The nodule at *F* is cut through the centre; the others near their margins. The mucosa *A* has been lifted by the swollen nodules. The summit of the largest nodule, *F*, has been eroded, forming the central pit-like depression seen in many nodules in Photo. II. It is a post-mortem change, but closely resembles commencing ulceration. Other post-mortem changes shown are the loss of superficial epithelium and the falling out of the tubular glands at *T*, *T*, *T*. The submucosa *C* is normal. At *M* is an accidental rent, separating the muscular coats *D* and *E*. *V*, *V*, are veins. The irregularity in the tubular glands seen in the right half of the drawing is due to a slight obliquity in the section.

FIG. 2.

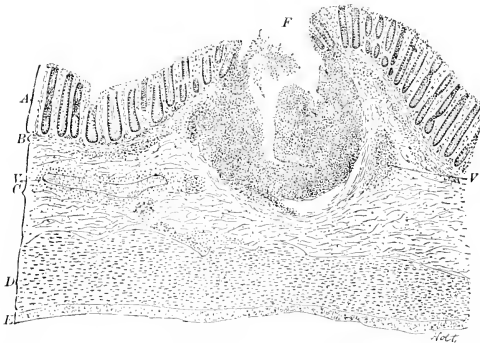

LYMPH-NODULE OF COLON IN THE EARLY STAGE OF ULCERATION (FOLLICULAR ULCER).

*History.*—Delicate child, thirteen months old; slight diarrhoea four weeks; acute severe symptoms five days; temperature 101° to 103° F.; all stools contained traces of blood; a few clots.

*Autopsy.*—Intense congestion throughout colon and great numbers of circular ulcers one-twelfth inch in diameter; one of these is shown in the figure. *A*, mucosa; *B*, muscularis mucosae; *C*, submucosa; *D*, circular; *E*, longitudinal muscular (section is transverse); *F*, follicular ulcer. The nodule is much enlarged, but is softening, breaking down, and discharging itself into the intestine. The overlying mucosa has been destroyed. The superficial epithelium is gone. The tubular glands are essentially normal, but at their bases and just above the muscularis mucosae is seen a moderate cell-infiltration, which is more marked just beneath the muscularis. There are also nests of new cells about the small blood-vessels *V*, *V*, etc. The vessel to the left of the drawing is cut longitudinally.



FIG. 3.

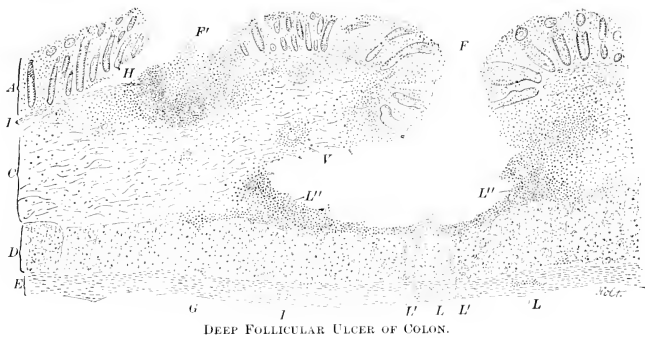

DEEP FOLLICULAR ULCER OF COLON.

*History.*—Thirteen months old; severe continuous intestinal symptoms three weeks; no blood in stools.

*Autopsy.*—Thirty-six hours. Numerous ulcers throughout colon; the largest nearly one-half inch in diameter in sigmoid flexure. The drawing is of one of the smaller ones, similar to smaller ones shown in Photo. V. *A*, mucosa; *B*, muscularis; *C*, submucosa; *D*, circular; *E*, longitudinal muscular; *F*, deep follicular ulcer; *F'*, superficial ulcer. All trace of lymph-nodule from which the ulcer *F* had its origin has disappeared; the destructive process has extended laterally in the submucosa, and the mucosa is falling in to fill up the space. The base of the ulcer is filled with round cells, *L'*, *L''*. Cell-infiltration has also occurred in the lymph-spaces between the bundles of circular muscle fibres at *I'*, *I''*; nests of cells are also seen in the lymph-coat at *L*, *L'*. *F'* is a superficial ulcer formed by destruction of the mucosa overlying the nodule. At *H* the mucosa has loosened from the submucosa.

The mucosa is extensively infiltrated with round cells. The tubular glands in some places have been compressed and destroyed; in others they are dilated and filled with new cells. Nests of cells are seen in many places about the small veins *V*. The whole intestinal wall is involved.

FIG. 4.



BROAD SUPERFICIAL ULCER OF COLON.

*History.*—Infant seven months old; continuous severe intestinal symptoms for four weeks.

*Autopsy.*—Thirty-three hours. Ulcers throughout colon; largest in descending colon and rectum. The gross appearances of similar ulcers are shown in Photo. III., C, and Photo. IV. One edge of a broad shallow ulcer is shown in the drawing. Only at the extreme left, *A*, does the mucosa appear. Here it is infiltrated with round cells and shows only a few remains of tubular glands, *T*, *T*. At *M* a ragged fragment of the mucosa still remains attached. The submucosa, *C*, is densely packed with new cells. They are more numerous in the upper part, which forms the base of the ulcer. Here and there towards the right are seen, at *T*, *T*, *T*, small remains of tubular glands. *F* is a lymph-nodule enlarged and beginning to soften. The muscular coats *D* and *E* are normal. The ulcer involves the mucosa only.





FIG. 5.

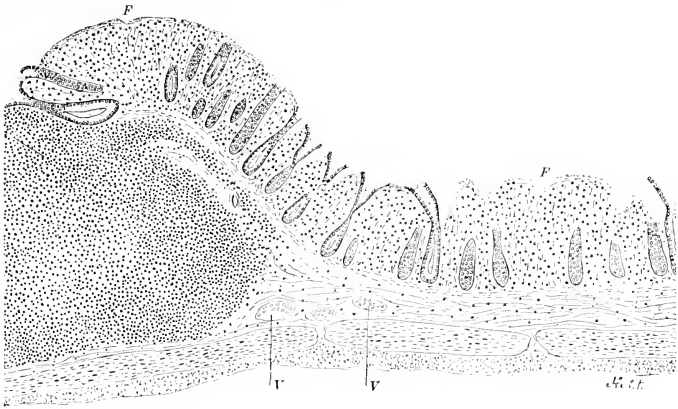

ACUTE CATARRHAL INFLAMMATION OF ILEUM, MILD FORM.

*History.*—Nine months old; previously healthy; three days sick, with acute intestinal symptoms; temperature  $103^{\circ}$  to  $105^{\circ}$  F.

*Autopsy.*—Two hours. Acute catarrhal inflammation throughout greater part of small intestine and in colon. Peyer's patches acutely congested and swollen. Section shown in drawing is from lower ileum.

In the left of the drawing is seen the edge of a Peyer's patch greatly swollen. Among the other signs of disease shown is almost complete loss of the superficial epithelial layer, this being present in places at the mouths of the tubular glands. Especial attention is called to the epithelial changes, this being a very early autopsy. In several places, as at *F, F*, tubular glands have also loosened and fallen out. There is a moderate infiltration with new cells of the entire mucosa, more marked near the Peyer's patch. The submucosa and muscular coats are normal.

(This drawing has been reduced less in the reproduction than the others, except Fig. 8.)

FIG. 6.

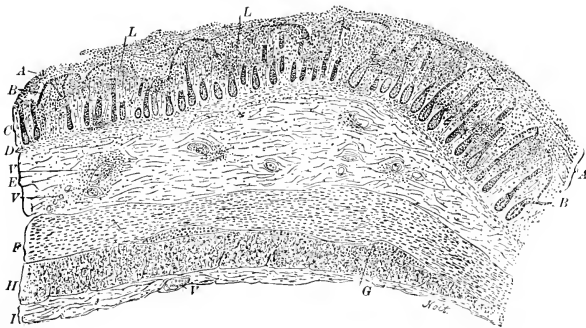

ACUTE CATARRHAL INFLAMMATION OF ILEUM.

*History.*—Six months old; mild diarrhoea twelve days, severe symptoms six days, with high temperature.

*Autopsy.*—Eight hours. Whole colon and lower two feet of ileum involved. Intestine congested, swollen, and much thickened. A grayish exudate on the surface of the lower ileum "resembling pseudo-membrane." The drawing shows a section from this region. *A, A*, is the exudation, which is composed of mucus and cells, but no fibrin. *B* is the superficial epithelial layer, the arches of which as it covers the villi are imperfectly preserved beneath the surface-exudation. *C* is the mucosa; the tubular glands are almost all seen. It is thickened chiefly from extensive cell-infiltration, which is seen everywhere, but here and there, as at *L, L*, the cells are so numerous as almost to efface the tubular glands and elsewhere to compress them.

The changes are almost exclusively in the mucosa. In the submucosa only a few new cells are seen, chiefly about small blood-vessels, as at *V, V*. The muscular coats *F* and *H* are normal. *I* is the subserous connective tissue. *G* is a sympathetic ganglion.



FIG. 7.

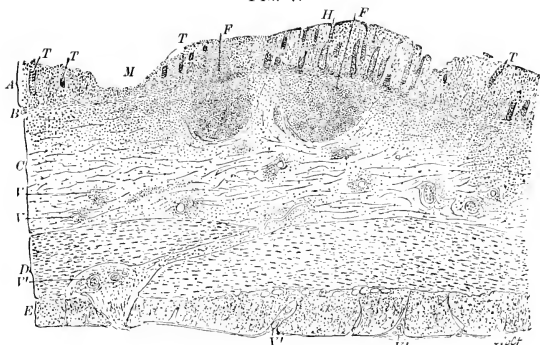

ACUTE CATARRHAL COLITIS, SEVERE FORM.

*History.*—Ten months old; breast-fed; previously healthy; sudden invasion, severe symptoms; temperature 102° to 106° F.; death in three days.

*Autopsy.*—Ten hours. Catarrhal inflammation in lower half of small intestine and whole colon, most intense in its lower portion. The drawing is of a specimen from the rectum. The mucosa, *A*, shows a great infiltration of new cells, with destruction of tubular glands; in places only small remains of these, *T, T, T*, are left. At *M* is a superficial erosion or catarrhal ulcer. Another is seen near the right extremity of the drawing. The superficial epithelium is gone, except at *H*, where it is present for a short distance.

The submucosa, *C*, is densely infiltrated with cells, especially at its upper part and about the small blood-vessels *V, V'*. *V', V''* are blood-vessels piercing the muscular coats. The thickening of the intestine is chiefly due to infiltration of the submucosa. *F, F*, are solitary lymph-nodules moderately swollen.

FIG. 8.

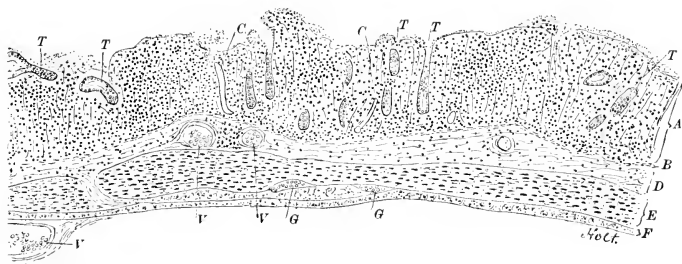

CHRONIC CATARRHAL INFLAMMATION OF THE ILEUM.

*History.*—Delicate child, thirteen months old; continuous intestinal symptoms for four months; during first two weeks high temperature; progressive wasting; weight just before death, eight pounds.

*Autopsy.*—Thirty hours. Gross changes slight; the section is from the middle ileum. A similar condition existed through a considerable part of the small intestine irregularly distributed, and also in the stomach. Slight changes in the colon. The lesions affect the mucosa, *A*, almost exclusively. It is much thickened, being considerably thicker than the other coats combined (compare Fig. 6). The tubular glands are extensively destroyed, some remains being seen at *T, T, T*, etc.; the villi scarcely project at all. There is a very great increase in cells, and some new connective tissue in the mucosa. Large capillary vessels are seen at *C, C*. The submucosa is thinner than normal, and contains many large blood-vessels, *V, V'*. About some of them a small increase of cells is seen. *G, G*, are sympathetic ganglia. The muscular coats *E, F*, are a little thinner than normal.

(This drawing has been reduced less in the reproduction than the others, except Fig. 5.)



FIG. 9.

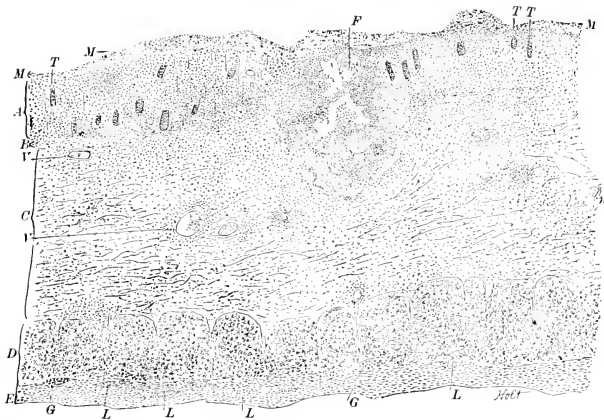

CROUPOUS INFLAMMATION OF THE COLON.

*History.*—Fourteen months old; ill nine days; temperature  $101^{\circ}$  to  $105^{\circ}$  F.; all stools containing blood, some small clots.

*Autopsy.*—Thirty-six hours. Lesions in lower ileum and whole colon: great thickening of intestine and pseudo-membrane in places: most marked changes in ascending colon, from which the specimen shown in the drawing is taken. *M, M*, is the pseudo-membrane, composed chiefly of granular fibrin. The mucosa, *A*, shows dense infiltration of cells, so great that tubular glands are almost entirely destroyed, small remains only being seen at *T, T*. In the right of the drawing the muscularis mucosa is also obliterated. It is seen in the left at *B*. The submucosa, *C*, is greatly thickened; this is partly due to the great accumulation of round cells seen quite to the muscular coat, but chiefly to fibrin, which the high power shows to infiltrate this coat everywhere, and also the mucosa. There are accumulations of cells at *L, L*, in the muscular coats. *V, V*, are small vessels with zones of cell-infiltration about them. *F* is a solitary lymph-nodule covered by the pseudo-membrane, but breaking down in its centre. *G, G*, are sympathetic ganglia.

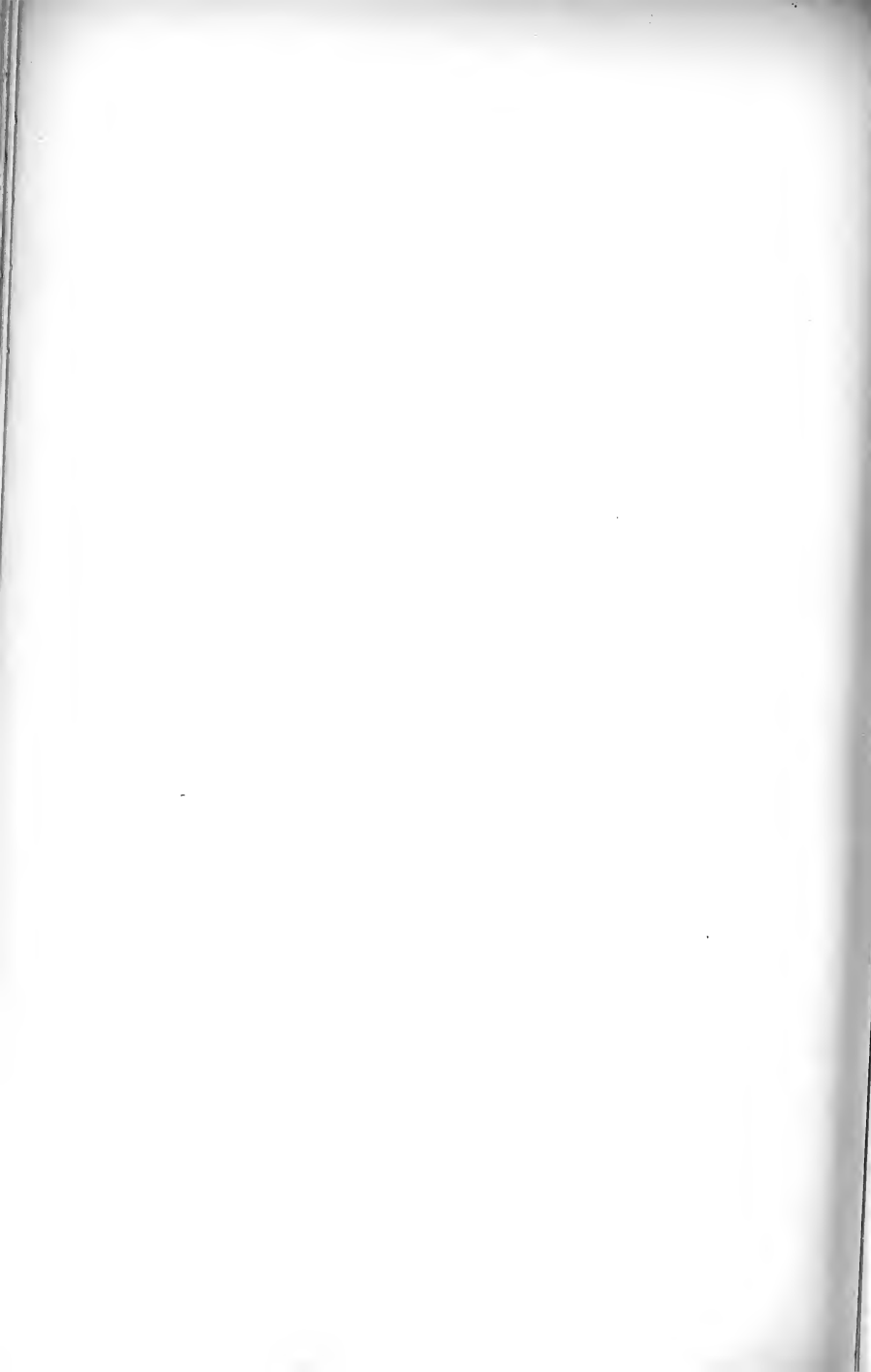

do not appear to me to be croupous, for the reason that I have never been able to find any fibrin in the exudation elsewhere, and nothing comparable in any way to them has been seen in any of the croupous cases examined.

The mode of healing of the follicular ulcers will be considered among the lesions of chronic inflammation of the intestine. This termination is, unfortunately, a rare one. I have seen only three cases in which healing or healed ulcers were found in the intestines in children. Ulcerative inflammation then is almost always fatal.

**IV. Acute Croupous Inflammation.**—This is the most severe form of intestinal inflammation seen in children. The terms “croupous” and “diphtheritic” are hardly descriptive, for the process differs quite materially from what is described as occurring among adults.

*Frequency.*—This lesion was found in nine out of seventy fatal cases. It is usually primary, being a very rare complication of diphtheria of the pharynx. The only instance I have seen was a specimen presented by Dr. Sellew<sup>22</sup> to the New York Pathological Society.

Clinically, this form usually runs a short, intense course, with a continuous temperature which is moderately high, severe general symptoms, and death generally in eight or ten days. The shortest case I have seen lasted six days. If recovery takes place, it is only after a very prolonged illness.

*Gross Appearances.*—There is visible to the naked eye very little pseudo-membrane and no deep sloughing. The lesion affects with remarkable uniformity the last two or three feet of the ileum and the whole colon. It is exceedingly rare to meet with any marked lesions high up in the small intestine. The most marked changes are usually in the neighborhood of the ileo-cæcal valve. They are quite as severe in the ileum as in the colon, but the process stops very abruptly. (See Photo. VII.) Often within a few inches we have a transition from a part the seat of intense inflammation to a nearly normal intestine. Next to the cæcal region the most severe lesions are usually found in the sigmoid flexure and the rectum.

The intestinal contents are usually green or greenish-brown mucus and faecal masses mixed with remains of food; occasionally they are of a brown coffee-ground color, almost never bloody. There is but little gas in the colon, and often it is nearly empty throughout.

The intestinal wall is firm and stiff, and is from two to four times the normal thickness. It is not thrown into deep folds, as is healthy intestine when empty. It is very rare to find false membrane that can be stripped off in patches of any considerable size. Where membrane exists, the color is a grayish green, and the surface is often fissured, giving a lobulated appearance. In the parts where no pseudo-membrane can be seen, the surface is usually of an intense red color, and is rough and granular, in striking contrast to the normal glistening appearance. (See Photo. VII.) Here and there small extravasations of blood can be seen in the mucous membrane, the largest of which may be half an inch long. Peyer's patches and the solitary lymph-nodules of the intestine are indistinct, and often cannot be

made out at all; nor can the villi be seen in the ileum. There are rarely any ulcers visible to the naked eye, unless this process is complicated by follicular ulceration, which is uncommon.

Although the whole colon is involved, the lesions differ very much in degree in the different regions, and it is very rare to find pseudo-membrane covering any considerable area. It is often limited to a few inches. In a single instance I have found a coating of fibrin on the peritoneal surface for a short distance. The small intestine above the lower ileum shows no constant or peculiar changes. It may present the changes of a slight catarrhal inflammation, but is quite as often essentially normal. In a very small proportion of the cases coexisting inflammation of the stomach is present.

*Microscopical Appearances.*—Under the microscope the changes are strikingly uniform. There is a dense infiltration of the mucosa with round cells, and usually of the submucosa also; there is wide-spread and often entire destruction of the tubular glands; fibrin coats the surface in a few places, in many there is none, in a very few cases there is some infiltration of fibrin into the deeper tissues. The lymph-nodules do not participate actively in the process.

The cell-infiltration is a marked feature, and occurs in irregular areas. In some places it is so dense as to efface all the normal elements of the mucous membrane. When not so abundant, the cells are more numerous in the upper part of the mucosa than in the lower: they compress the tubular glands, often causing them to assume a flask-like contour. In the submucosa the cells are especially abundant in two situations,—just beneath the muscularis mucosæ, and about the small veins. Exceptionally the whole submucosa is densely packed quite to the muscular coat. Nests of cells may even be seen in the muscular layer or in the subserous cellular tissue. These cells are small round lymphoid cells. (See Fig. 9.)

The tubular glands in places are entirely destroyed, not a vestige remaining for some little distance. In other places we see, here and there, small remains of these structures,—usually the deeper parts, those more superficial having disappeared. In still other places we see them widely separated by the accumulation of cells, and variously compressed and distorted.

Where the tubular glands have disappeared entirely, the mucosa is filled with granular detritus of broken-down cells, round cells which infiltrate the adenoid tissue between the glands, and sometimes fibrin.

Fibrin is seen in most cases upon the surface only, and here only in certain parts of the specimen. The amount is usually small; in some we can scarcely find any. Fibrin is often found under the microscope in the “granular” parts of the specimen, where no pseudo-membrane could be made out by the naked eye. In a few cases coagulated fibrin is seen in the adenoid tissue of the mucosa, in the interstices of the connective tissue of the submucosa, and even upon the peritoneal surface. The pseudo-membrane upon the surface usually amounts to about one-fourth the thickness



of the normal mucosa. It is made either of granular fibrin containing but few cells, or a net-work filled with round cells and often red blood-globules. Bacteria are present, but not usually numerous.

It is to the dense cell-infiltration of the submucosa, and the coagulated fibrin here, with usually some œdema, that the chief increase in thickness of the intestine is due, rather than to the pseudo-membrane on the surface.

The muscular coats show no changes beyond round-celled infiltration and, more rarely, coagulated fibrin.

The blood-vessels are everywhere gorged with blood. Sometimes the submucosa seems literally filled with these distended vessels. Even the small vessels of the mucosa are greatly increased in size. In many cases we find smaller or larger extravasations of red blood-globules into the mucosa or the submucosa.

Sloughing, with the formation of deep ulcers, I have never seen in this process in children. In this respect there is a striking contrast with the adult cases.

There is but little change of the lymph-nodules unless they have been diseased preceding the croupous inflammation. In these instances we may have great swelling of the nodules, and even the formation of follicular ulcers; but this combination is rare.

OTHER LESIONS PRESENT IN CASES OF ACUTE DIARRHEAL DISEASES.—*Brain*.—Notwithstanding the frequency of cerebral symptoms, it is very exceptional to find any sufficient explanation for them in the appearances seen at the autopsy. Overlapping of the bones of the skull to a slight degree is occasionally seen in the rapidly-fatal cases in very young infants. A slight increase of the cerebro-spinal fluid is not uncommon, but seems to me of no special significance. Thrombosis of the sinuses of the dura I have never seen, although others have described it. It is certainly not a frequent lesion. Congestion of the brain is not infrequently seen in cases dying with high temperature and convulsions, but apart from the latter symptom it has not seemed to be more common or more striking than in the generality of autopsies. In a single case I have seen a very marked anæmia of the brain which seemed to be the explanation of the cerebral symptoms. They were so decided in this patient that the case was regarded as one of undoubted meningitis. The brain was almost bloodless.

*Mouth*.—The catarrhal and follicular forms of stomatitis are quite frequent. They are discussed under symptomatology.

*Lungs*.—Tuberculosis has been met with in several cases where the patients died of intestinal disease in no way connected with tuberculosis. By far the most frequent lesion in the lungs was broncho-pneumonia. It was present in one-sixth of all the cases. In the cases which had lasted ten days or over it was present in nearly one-half. In six cases it was the immediate cause of death. In the others the amount of pneumonia was small. The most common variety is a subacute form which develops in the dependent portions of both lungs, being usually most marked in the

lower lobes. Less frequently the acute form was seen resulting in more or less diffuse areas of consolidation in one or more lobes.

In a single instance complicating ulcerative colitis I have met with a case of pneumonia in which a large abscess formed in the upper lobe of the lung. There were no other abscesses in the body, and no tuberculosis. There is nothing peculiar in the pneumonia complicating intestinal disease. It occurs just about as frequently and with precisely similar appearances in other diseases whose general symptoms and course are similar. More or less congestion of the lungs, usually hypostatic, is seen in nearly every case.

Pleurisy I have never seen apart from pneumonia or tuberculosis. Bronchitis of the larger tubes is very common.

*Heart.*—This organ is usually pale and contracted. I have never met with any lesion of importance in the endocardium, pericardium, or heart-muscle.

*Intussusceptions* were seen in about ten per cent. of the cases; they were most frequently met with in the short, acute cases. They are multiple, very often twelve or fifteen in one case. They are undoubtedly produced during the death-agony, and are of no pathological importance.

*Peritoneum.*—General peritonitis was never seen, nor was serous transudation into the peritoneal cavity. Localized plastic peritonitis was met with in a single case of croupous inflammation.

*Kidneys.*—Ever since the writings of Kjellberg<sup>23</sup> it has been the custom to speak of the great frequency of nephritis in these cases. My own observations have not confirmed his results. I have found well-marked nephritis in but a single case. Cloudy swelling of the epithelium of the tubules is very common, and is seen in almost all cases where the temperature has been high. Taking the cases as a group, however, the renal changes are just what one meets with in pneumonia or in any other acute febrile disease, but are no more marked.

*Liver.*—In the acute cases there have been no constant or characteristic changes. The organ is frequently pale, but in all other respects normal.

*Spleen.*—In a small number of cases I have found the spleen moderately swollen, but in the majority there is nothing abnormal either in its size or in its general appearance.

*Stomach.*—As microscopical examinations of this organ have not been made in all cases, it is impossible to state the exact frequency with which the stomach was involved. In the acute desquamative cases, changes in the stomach were quite constant and closely resembled those seen in the intestines. In two or three instances they were more pronounced than in the intestines.

In the acute catarrhal cases the stomach was involved in about one-half the cases. In the acute croupous cases and in the cases of follicular ulceration it was quite exceptional to find lesions in the stomach.

*Mesenteric Glands.*—These lymph-nodes are involved in almost every

case. In the most recent ones they are red, in those of longer duration sometimes pale. In no instance were they softened or broken down.

The lesions of the skin are considered among the symptoms.

**V. Chronic Inflammations of the Intestine.**—I have included under this head several varieties differing quite widely.

**1. CHRONIC HYPERPLASIA OF THE LYMPH-NODULES.**—This may occur as a primary or as a secondary condition. It is found in infants who have suffered for weeks or months from the symptoms known as chronic dyspeptic catarrh, occurring more often in those who are cachectic. It is also seen in those who have previously suffered from repeated mild attacks of diarrhœa, and sometimes when there is a history of antecedent severe diarrhœa. The lesion is apparently not of so much importance *per se* as in its relation to acute inflammation and ulceration of the lymph-nodules. A study of the clinical history of these cases seems to show that the existence of these swollen lymph-nodules predisposes strongly to follicular ulceration.

The gross appearances of these enlarged lymph-nodules have already been described under acute catarrhal inflammation. In those occurring slowly they are usually more of a yellowish color. They are found almost exclusively in the colon, those of the small intestine and Peyer's patches participating but rarely. (See Photos. I. and II.)

Pigmentation occurs in a few of these cases, but in most it is absent. There may be some slight congestion of the mucous membrane, but nothing of any moment.

Microscopically, there is seen chiefly an enormous increase in the number of cells of which these nodules are largely made up. The swollen nodules raise the mucosa and crowd the tubular glands aside, infiltrating the tissues immediately overlying them. (See Fig. 1.) Otherwise there are no intestinal changes belonging to this condition. Once produced, these hyperplastic nodules are very slow in disappearing: they may last indefinitely. I have found them in one case five months after the cessation of all symptoms.

The lymph-nodes lying in the mesentery (mesenteric glands) are invariably found to be swollen, and frequently reach the size of an inch in length and half an inch in thickness. They are generally of a pale-gray color. Microscopically they give the usual appearance of swollen lymph-nodules elsewhere in the body. They show no tendency to caseation or abscess.

**2. CHRONIC CATARRHAL INFLAMMATION FOLLOWING THE ACUTE FORM.**—This lesion is not nearly so frequent as might be supposed from clinical observation. In a great number of the cases where acute attacks have been followed by more or less persistent intestinal symptoms, we find little else than the hyperplasia of the lymph-nodules just described. As in the acute catarrhal variety, this lesion is more likely to involve the small intestine than are some of the other pathological processes. It is likely to be wide-spread, although differing very much in intensity in different regions.

*Gross Appearances.*—These are not characteristic, and differ so little

from those of normal intestine that they may be easily overlooked. Closer examination of the small intestine may show to the naked eye, but it is better seen with a lens, that the villi are much less distinct than normal, and in places are wanting altogether. The intestine may be distended until it is as thin as parchment, or it may be thicker and firmer than normal. There is no recent congestion, the usual color being slate-color or gray. Sometimes dark streaks of pigmentation are seen in the general mucous membrane; at other times this is limited to the Peyer's patches and the solitary lymph-nodules.

Peyer's patches are not often enlarged, and they may even be less prominent than normal. The solitary lymph-nodules in the colon usually show more or less enlargement, but no ulceration. The mesenteric lymph-nodes are always enlarged, but usually pale.

*Microscopical Appearances.*—These are striking, and are often a great surprise when so little change has been seen in the gross specimen. The lesion is essentially one of the mucosa; the essential features are a disappearance of very many of the tubular glands, and, in the small intestine, of the villi also; a very great proliferation of cells in the adenoid tissue of the mucosa, and, if the disease has existed long enough, a production of new connective tissue. (Fig. 8.)

The lesions are found irregularly distributed; in places there may be complete obliteration of the normal elements of the mucosa, while in others they are very little altered. The superficial epithelium is often entirely gone for a considerable extent. If the reparative process has begun, in certain parts it may have been perfectly reproduced.

The tubular glands are small, often completely destroyed; in other places there are seen here and there remains of these structures displaced, compressed, and variously distorted by the inflammatory products. In the regions most affected the villi have ceased to project much above the rest of the mucosa, and have the appearance of being matted into the mass of inflammatory materials, so that all trace of their original contour is lost. But a little distance from these areas we may find others in which the changes are slight.

There is a very marked infiltration of the mucosa with round cells, but the submucosa is usually free from them. The mucosa is made up of these cells, the remains of villi and tubular glands, dilated blood-vessels, the normal reticulum of the adenoid tissue, and, if the lesions are old, new connective tissue has formed. As Woodward<sup>20</sup> has observed, it takes a very long time for connective tissue to form in these cases, contrasting in a striking way with the rapidity with which it develops in the healing of ulcers.

The submucosa is usually thinner than normal, but may be thickened from cell-infiltration and the production of new connective tissue. Atrophy of the muscular coats has been described by some writers, but I have not seen any that was pronounced. The blood-vessels are found very much enlarged. Amyloid degeneration of their walls I have not seen.

The solitary lymph-nodules of the colon may show nothing more than the changes described in the previous paragraph, or there may be a slight increase in fibrous trabeculæ; but I have met with no changes marked enough to deserve the term of induration or sclerosis, as described by Baginsky,<sup>4</sup> or as seen among adults by Nothnagel.<sup>21</sup>

These cases differ very much in the extent and distribution of the lesions; the longer they have lasted the more widely spread they are. The only typical example I have had an opportunity to study showed very marked changes in the small intestine, similar but less pronounced in the stomach, and very slight in the colon.

3. CHRONIC INFLAMMATION FOLLOWING THE ACUTE CROUPOUS FORM is described as occurring in adults where ulcers have formed from the process of sloughing. Sloughing is a very rare occurrence in infancy, and an acute inflammation of such severity would be almost certainly fatal. I have never seen such ulcers, nor have I met with a clear description of them.

4. CHRONIC INFLAMMATION FOLLOWING FOLLICULAR ULCERATION.—This is but infrequently seen at autopsy, since nearly all the cases of ulceration terminate fatally in the acute stage. They sometimes linger along for several months with continuous intestinal symptoms, and die of some intercurrent disease, most frequently of pneumonia. At autopsy we find these ulcers in various stages of repair, and sometimes associated with the formation of cysts.

(1) *The Mode of Healing of Follicular Ulcers.*—The overhanging edges described in the acute cases (see Fig. 3) fall in upon the submucous or muscular coat, as the case may be. The pit-like cavity left is partly filled up by granulation-tissue; new connective tissue develops in the mucosa between the tubular glands and in the submucosa. New epithelium forms very readily over the granulation-tissue which fills the cavity, and there may be left a simple indentation scarcely noticeable, or a broader cup-shaped depression; or, if the ulcers have been larger, the cicatricial tissue which forms is so abundant that its contraction may cause a puckering in the surface, sometimes a stellate cicatrix.

The time required for the process of healing varies, no doubt, much in the different cases and in different parts of the intestine, so that we may find at the same time ulcers entirely healed and those in which the process of repair is scarcely begun. From two to three months seem to be required in the case of ulcers of the average size.

It is extremely doubtful if stricture ever results from this form of ulceration in children.

The rest of the intestine in these cases shows the lesions of a more or less severe chronic catarrhal inflammation.

(2) *The Formation of Cysts in the Colon.*—This is one of the rarest lesions seen in chronic inflammation of the intestine. I have placed this lesion among the changes associated with follicular ulceration, although some hold it to belong rather to the catarrhal cases. The fully-developed cysts

I have seen in but a single case. There was in this case first an ordinary attack of acute enterocolitis in a child a year and a half old, which gradually passed into a chronic condition, the intestinal symptoms lasting four or five months continuously. The infant never regained his health, and died about a year later from intercurrent disease.

In the descending colon and rectum about twenty of the larger cysts were found, and some smaller ones. The larger cysts were about one-sixth of an inch in diameter, and had a very thin, transparent membrane covering them, through which their colorless contents were distinctly visible. They projected considerably from the intestine, but were sessile. Upon section their mucoid contents escaped. It was perfectly transparent, and in general appearance and consistency resembled the vitreous humor of the eye. The smaller cysts appeared only as small warty elevations in the mucous membrane, which had its normal color. The only other essential lesions in the intestines were cicatrized follicular ulcers. The microscopical examination in this case gave no clue to the origin of these cysts. They were found to be situated in the submucosa, covered by a mucosa more or less attenuated, in some places differing but slightly from the mucosa a little distant. The capsule showed no trace of epithelial lining.

These cysts have been fully described by Woodward, who has given the only account of them I have seen in English. He states that they were first fully described by Kelsch<sup>24</sup> in 1873.

They are undoubtedly produced by dilatation of the tubular glands, some of which sink or grow into the submucosa in the space occupied by softened or ulcerated lymph-nodules. The orifice becomes closed, and the tubule becomes distended by the accumulated pent-up secretion of the mucus-cells of the gland. I have myself seen, in one autopsy, upon a case of follicular ulceration of eight weeks' standing, the early stage of this process.

AMYLOID DEGENERATION is rarely seen in infancy. It is not so rare in older children, where it occurs with amyloid degeneration of the liver, spleen, and kidneys, most frequently as a result of prolonged suppuration with chronic bone- or joint-diseases. It may occur in syphilis or tuberculosis.

The symptomatology of these cases is still unsettled. The process begins by affecting the walls of the arterioles and capillaries, particularly of the villi (Woodward), and later the vessels in the submucosa. After the blood-vessels the epithelium may become affected.

The mucous membrane in these cases is pale and rather transparent. Upon the application of the iodine test to the small intestine many red or brown points appear where the villi have been affected.

THE INTESTINES IN ATHREPSIA OR INFANTILE ATROPHY.—It seems proper to introduce here a few remarks upon this subject, since certain German and French writers have taken the ground that the essential lesion in a considerable number of these cases is intestinal atrophy,—*i.e.*, a con-

dition similar to what has been described above under the head of chronic catarrhal inflammation.

I have examined microscopically the intestines of twenty cases of athrepsia or marasmus. Fourteen of these cases died with intestinal symptoms, usually of short duration. In all of them the symptoms of marasmus had existed long before the intestinal disorder. In the remaining six there were no special intestinal symptoms.

In no case of either series was there anything bearing the least resemblance to "intestinal atrophy." The diarrhoeal cases usually showed only the changes described as acute desquamative catarrh of a mild degree, the lesions being, as a rule, less pronounced than those seen in children who were previously in fair condition, probably because the former class succumb readily to disease of no great severity.

In the six cases without intestinal symptoms there was practically nothing abnormal in the intestines. Two cases in which autopsies were made three and four hours respectively after death, showed intestines as nearly normal as I have ever met with in an infant. In view of these facts, we cannot accept without further evidence the proposition that the cases of primary infantile marasmus or athrepsia are to be explained by intestinal atrophy.

OTHER LESIONS IN CHRONIC INFLAMMATIONS.—Those belonging to the skin, mouth, and eyes are considered in the section upon symptomatology.

The lesions of the brain are for the most part accidental complications. Hydrocephalus and chronic meningitis have been met with occasionally, but they are rare.

The pulmonary lesions are essentially those already described in the acute forms of inflammation of the intestines. They consist of hypostatic congestion, subacute or chronic broncho-pneumonia, and pulmonary tuberculosis.

The liver has been found extremely fatty in one or two cases, but hepatic abscess as a result of intestinal ulceration has never been met with.

The kidneys nearly always show more or less of cloudy swelling, and in one case I have seen a pronounced degree of chronic nephritis.

Dropsical effusions into the serous cavities are not frequent, but are sometimes met with.

General tuberculosis is a very frequent cause of death.

---

#### IV. THE STOOLS IN DIARRHOEAL DISEASES.

*A healthy stool of a nursing infant or one upon an exclusive milk diet varies in color from a pale yellow to a deep orange; it is smooth, homogeneous, and of a butter-like consistency, acid in reaction, of a slightly sour*

but not disagreeable odor. The reaction depends upon the presence of lactic acid (Uffelmann<sup>26</sup>), the source of which is the milk-sugar. The color is due to bilirubin.

The only gases present are H and CO<sub>2</sub> (Escherich); H<sub>2</sub>S and CH<sub>4</sub>, to which the odor of adult stools is largely due, are not present. The following chemical analysis is from Wegscheider:<sup>26</sup>

Water, average . . . . .		85.13
Solids {	organic, 13.71 } . . . . .	14.87
	inorganic, 1.16 } . . . . .	
		100.

There are no peculiar albuminoids; those existing in mother's milk seem to have been almost completely absorbed.\* Peptone exists only in very small amount. Sugar is absent.

Fat is the chief organic ingredient: it is found as unaltered fat, free fatty acids, and saponified. Of biliary elements, there are hydro-bilirubin, unchanged bilirubin, and cholesterin in considerable amount. The presence of biliary acids is doubtful.

Of ferments, pepsin is absent, but there are traces of the pancreatic ferments.

Mucus is always present in considerable amount; also columnar intestinal epithelium. Leucin, tyrosin, and other products of albuminous decomposition, phenol and scatol, are absent; indol is rarely found. (Uffelmann). The inorganic salts are chiefly those of lime.

Microscopically, there are seen epithelial cells, chiefly columnar, a few round cells, mucus-corpuseles, fat-globules and crystals of fatty acids, cholesterin, mucin, protein substance, crystalline inorganic salts, sometimes bilirubin in crystals, yeast fungi, and bacteria in immense numbers, chiefly the bacterium coli commune of Escherich.

The number of stools during the first two weeks is from three to six daily. After the first month two stools a day are the average; many infants have three, many others but one.

As soon as an infant is put upon a mixed diet the peculiar characters of the stools cease, and they come to resemble more those of the adult, though remaining softer and thinner throughout infancy. They become darker in color, and assume the adult odor, while retaining their acid reaction. The bacteria, while still in great numbers, are no longer of the single variety met with almost exclusively in milk stools.

#### STOOLS IN DISEASE.

As a rule, in all varieties of intestinal catarrh the number of stools is increased. An exception is in certain forms of chronic catarrh, like that

---

\* Tschernoff (*Jahrb. für Kinderheilk.*, Bd. xxviii. H. 1) publishes analyses of the albuminous matter of stools, estimated from the amount of nitrogen, which differ very materially from those previously made by Wegscheider, Uffelmann, and others. He makes the amount of albuminous matter many times greater.



occurring in rickets, where the number may be less than in health, or where diarrhœa may alternate with constipation, the same pathological process existing in both cases.

In diarrhœa the number of stools may reach twenty a day, or even more. Usually the number is inversely proportional to the size of the stools,—an exception being the case in choleraic diarrhœa, where the discharges, although large, may be repeated every half-hour.

**Consistency.**—This depends upon the amount of water, mucus, and fat present. It is rarely the case that stools in disease are thicker than normal, but it sometimes happens that loose stools alternate with stools of an ashy-gray color, thick, dry, and of a very foul odor. These stools contain large amounts of fat. The amount of water and mucus usually predominates so much over the increase in fat that diarrhœal stools are much thinner than normal. They may be almost pure water, so that the napkins are soaked without any solid deposit upon them. These watery stools are never seen at the beginning of an attack, but may supervene in the course of an illness at any time; they are always an unfavorable symptom, and a return to more consistent stools is a sign of improvement.

**Reaction.**—The great proportion of stools in diarrhœal disease, as in health, are acid; the next most frequent condition is a neutral reaction; while distinctly alkaline stools are comparatively uncommon. Thin grass-green stools are usually acid, although this acidity may be less than in health. Alkaline stools are most frequently those which are large, thin, yellow, and very foul, or the choleraic stools, odorless, and almost entirely serous.

It is still a disputed point whether the reaction of the stools is a trustworthy guide to the nature of the process of decomposition going on in the alimentary canal. My own view is that it is of very doubtful value. It varies in the same case from day to day, and is modified to a large degree by food, and somewhat by drugs.

**Color.**—*Green Stools.*—These are seen in the early stage of almost every case of dyspeptic diarrhœa, and form a striking feature. The color varies all the way from a pale greenish yellow to a bright grass-green. In consistency the stools may be thick or watery; they may be, but are not commonly, of foul odor. They are usually acid, frequently neutral, but rarely alkaline, in my experience. This color may persist through the attack. We cannot accept as conclusive the observations of the French writers Hayem and Lesage,<sup>9</sup> who assert that a specific germ is the cause of the color of these stools. Wegscheider<sup>26</sup> has shown that the green color depends upon preformed biliverdin. The condition in the intestine upon which the transformation of bilirubin into biliverdin depends has been generally regarded as one of acid fermentation. Pfeiffer's<sup>27</sup> experiments seem to show that this long-received opinion is erroneous. In the first place, he found that none of the acids formed in such fermentation,—lactic, acetic, butyric, propionic, etc.,—added to yellow stools outside the body, would turn them green, but

made them a deeper yellow. However, dilute alkaline solutions added to fresh yellow stools turned them green after an exposure of thirty to sixty minutes, and strong solutions turned them first brown, and later, after exposure to the air, an intense green.

It is well established that the intestinal tract in a nursing infant is acid throughout. Pfeiffer holds that green stools are evidence of alkalinity somewhere in the canal, any such alkalinity being pathological. The acidity of green stools is not the cause of their color, but depends upon the acid reaction of the colon. It is less, Pfeiffer states, than in normal yellow stools.

Stools which are pale yellow when discharged and which afterwards become green are often seen in disease; they may be themselves neutral or alkaline in reaction, or this may depend on the admixture of urine. Pfeiffer produced typical green stools in a healthy infant by giving two grains of sodium bicarbonate hourly for two days. When this was withheld and hydrochloric acid given, the normal yellow color was restored.

This seems to be the best explanation yet offered for the color of green stools. I have repeated some of Pfeiffer's experiments upon stools, with a confirmation of his results.

In certain cases the stools are green from an excess of bile.

*Brown stools* may be due to changed biliary pigment, to certain drugs, —bismuth, vegetable astringents containing tannin, or iron. In some instances the color may be almost black. Blood, from the stomach or the small intestine, may give the stools a black, tarry color. The stools of an infant may be brown from a diet consisting largely of broth or other animal foods.

These stools may be of any consistency or reaction. In severe forms of dyspeptic diarrhoea, and sometimes in entero-colitis, we have brown stools which contain almost no solid matter, and are like muddy water, often very offensive in odor.

*White or light-gray stools* are usually of a putty-like consistency, sometimes like dry balls upon the napkin, sometimes resembling ashes. They are usually exceedingly offensive, and are made up very largely of fat, bile being greatly diminished or absent altogether.

*Bright-red stools* are due to admixture with blood. If it comes from the lower colon or the rectum, it is not mixed with the stool. If from higher up, it streaks the stool only, or may appear only as brownish-black masses.

**Mucus.**—Although this is present in all healthy stools, it is so intimately mixed and in such small quantity that it does not appear as mucus to the naked eye. Any such appearance may be regarded as abnormal. Mucus is present in considerable quantity at some stage in the process in almost every case of intestinal disease. It is much more abundant in inflammations of the large than in those of the small intestine, and is especially so in the subacute and chronic forms of colitis.

When from the rectum or the lower colon, it appears in jelly-like masses or shreds, and may make up a large part of the stool. If from the upper colon, it is usually more or less intimately mingled with the rest of the

stool; if from the small intestine, this is always so, and, in addition, it is usually bile-stained. Shreds of mucus in the stools may sometimes resemble false membrane. Washing with a stream of water quickly shows the difference; the mucus is broken down, while the other is not affected.

**Food-Remains.**—*Fat.*—One of the first changes noticed in the composition of dyspeptic stools is the increase of fat. Often the stool as a whole is quite green, but contains small masses of a yellowish-white color which vary in size from a pin's head to a large pea, or even larger. These masses were long regarded as lumps of undigested casein, and were first shown by Wegscheider to consist almost entirely of fat. Baginsky points out that they always contain large colonies of bacteria. These masses may be so numerous that the stool is in great part made up of them. They are distinguished from casein lumps by their solubility in alcohol and in ether.

The term *fat diarrhoea* has been used by Demme<sup>28</sup> to designate this condition in an aggravated form. Since then others have written upon it, especially Biedert.<sup>29</sup> In some of the reported cases the percentage of fat rose from thirteen and nine-tenths per cent., the normal (Uffelmann), to fifty per cent. and even to sixty-four per cent. Of twenty cases observed by Demme, nine were fatal. These cases are to be regarded as extreme cases of intestinal dyspepsia, but whether the liver or the pancreas is at fault we do not as yet know.

*Casein* is not nearly so common an ingredient of stools as is generally supposed. As stated above, what was formerly regarded as casein has been shown to be almost entirely masses of fat. Genuine casein lumps are usually hard, smooth, and of a yellowish-white color outside, but white within; they give a cheesy odor when broken down. Casein is seen occasionally in semi-transparent, horny masses, of irregular shape, giving the appearance of having been long in the intestine. Casein lumps may be seen at any time in the course of a diarrhoeal attack when milk has been given as a food. They bear no relation to the other elements of the stool. In the chronic cases they are most numerous.

*Starchy Foods.*—In children fed largely upon these substances they appear in the stool in considerable quantity, and may make up a large part of the solid matters of the stool. Certain substances, such as the remains of oatmeal, barley, or wheat, may be evident to the naked eye. Under other circumstances a chemical or microscopical examination of the stool is necessary to discover them. If the amount of starch is large, the addition of the iodine solution may cause the whole stool to change to a dark blue or a black. The microscope shows starch granules more or less broken down and irregularly stained.

*Other elements*, such as muscle-fibre, etc., are found in more or less quantity, recognized only by the microscope: they are of no special significance.

**Epithelial cells** are found in large numbers in all diarrhoeal stools, and are more abundant in proportion to the acuteness of the process. The great proportion of the cells are cylindrical epithelium. In addition to isolated

epithelial cells, numbers are often found attached to a basement-membrane, and even entire tubular glands are sometimes seen, they having loosened and fallen out. The cells are found in all stages of degeneration. To draw any inferences from the state of these cells respecting the condition of the epithelial lining of the intestine seems to me hardly justifiable. Pavement epithelium is rare, and probably comes most frequently from the anus.

**Round cells** are found, both large and small, in almost all diarrhoeal stools. In simple catarrhs their number is not large. Nothnagel has pointed out the striking contrast offered by the intestinal mucous membrane in this respect to that of the respiratory tract. They are found, according to this writer, in large numbers, almost exclusively in the ulcerative forms of inflammation. Baginsky, however, has found round cells in large numbers also in the severe forms of catarrhal inflammation; but they are not so constant a feature. The continued presence of large numbers of round cells in the stools is considered by both these writers to be almost conclusive proof of the existence of intestinal ulceration.

**Blood** may be in such small quantity as to be recognized only by the microscope, or in large masses, clots, or clear fluid blood. The last two are almost never seen except in inflammation involving the lower portion of the colon and the rectum. Blood from higher up appears in dark tarry masses, or intimately mixed with the rest of the stool.

The source of the blood is almost always the capillary vessels of the mucous membrane; it is very rarely from the opening of larger vessels by ulceration. It belongs, therefore, more commonly to the early stage of congestion, and not to the later one of ulceration. (See symptoms of ulceration.)

Patches or shreds of **pseudo-membrane** are rarely seen in the stools in infancy; they are not quite so rare in later childhood. Stools must be washed with water before such patches are distinguishable.

**Parasites.**—In the literature of diarrhoeal diseases of one or two decades ago, a prominent place was by many writers given to the description of monads and various other infusoria which were found in diarrhoeal stools. They were carefully studied first by Lambl,<sup>30</sup> and since him by several writers, including Woodward and Nothnagel, and more recently by Von Jaksch.<sup>31</sup> Their relation to diarrhoeal diseases has never been established, and it scarcely seems necessary to describe here the forms studied. They can be found in the writings referred to.

The various forms of intestinal worms are occasionally found in diarrhoeal stools, but their presence is accidental only.

**Bacteria.**—These are found in immense numbers in all stools, healthy and diarrhoeal. Morphological descriptions alone of the various forms met with are not only unnecessary but profitless. It is only by cultures that the identity of bacteria can be established. For an account of what has been done with cultures, the reader is referred to the article of Dr. Booker in this volume.

## V. GENERAL PROPHYLAXIS.

There is no class of diseases in pediatrics in which so much can be done in the way of prevention as in those of the gastro-intestinal canal. So long as dentition and atmospheric heat *per se* were regarded as the great causative factors, the field of prophylaxis was limited. But a better understanding of the etiology brings with it possibilities in prevention which are almost without limit. Could proper prophylactic rules be carried out, these diseases would cease to be what they are now, the greatest scourge of infancy.

Prophylaxis must have regard—

1. **To the hygienic surroundings** of children and to all sanitary conditions in the cities,—cleaner streets, more open parks, and better sewerage. Although these are not strictly filth-diseases, yet filth certainly conduces to their development. In the tenement-homes and all institutions for infants there should be more air and sunlight, less crowding, greater cleanliness about the persons of children, frequent bathing, and proper care of diapers. These in summer should either be washed immediately, or thrown into a disinfectant solution. In case infants are sick with diarrhœa this latter plan should invariably be followed.\*

In regard to dress, the tendency is to keep young infants too hot: this should be avoided; and, on the other hand, at the sea-shore or in the mountains, the opposite danger of insufficient clothing, especially night and morning, in summer hotels and boarding-houses where no fires are to be had.

City children should be sent to the country, wherever it is possible, for the months of July and August. Part of the benefit here is derived from the change of air, and a larger part from the pure milk, which we might almost say is possible in the hot season only in the country. Where a long stay is impossible, excursions for a day do much. Our fresh-air funds and sea-side homes have done more in New York to diminish the mortality from diarrhœal diseases than all our medicinal treatment; their importance and value cannot be over-estimated.

In a general way everything should be done that is possible to build up the general health of the infants.

---

\* The necessity of proper disinfection in stools is illustrated by the following, which recently came under my notice.

In a country house to which children from the city, sick mainly with intestinal diseases, had been sent, there had been up to a certain date the most marked and uniform improvement in all the infants. The woman who washed the napkins was now taken sick, and before another could be obtained these were allowed to accumulate to the number of two or three hundred, in large tin cans which were placed in a small yard in the rear. In a day or two, with July heat, the stench from this source became very marked; but before this was appreciated or removed, within thirty-six hours two cases of genuine cholera infantum developed, proving fatal, a marasmus child died, with intestinal symptoms, and exacerbations occurred in several other diarrhœal cases which were previously improving.

The place was emptied for a few days, and thoroughly disinfected, and no further trouble occurred.

2. **Foods and Feeding.**—Maternal nursing should be encouraged by every possible means. No weaning should be done, if it can be avoided, during summer. Nothing is better established than the close relation existing between hand-feeding and diarrhoeal diseases. This is not, however, because of the hand-feeding in itself, but because this feeding has been so ignorantly done. We have not space here to discuss the whole subject of hand-feeding; for this the reader is referred to Dr. Rotch's article in volume i., with almost all the views of which we are in hearty accord. The main points associated with the production of diarrhoeal disease may be grouped under the heads of overfeeding, too frequent feeding, improper foods, and impure foods.

*Overfeeding.*—While it is certainly true that the majority of infants among the better classes who are nursed entirely by the mother are underfed, it is still more true that almost all hand-fed infants among all classes are greatly overfed. The following table is derived from weighing a number of healthy infants before and after nursing, when they were nursed at proper intervals, to see how much they actually got at a nursing; and by measuring the capacity of nearly forty infants' stomachs at the different ages, these being carefully distended just sufficiently to obliterate the rugæ.

AGE.	ONE FEEDING.	NUMBER OF FEEDINGS.	DAILY AMOUNT.
2 weeks . . . . .	2 ounces.	8	16 ounces.
1 month . . . . .	3 "	8	24 "
2 months . . . . .	4 "	7	28 "
4 " . . . . .	5 "	6	30 "
6 " . . . . .	5½-6 "	6	33-36 "
9 " . . . . .	7-7½ "	5	35-38 "
12 " . . . . .	8-9 "	5	40-45 "

These figures may be taken as the proper amount for an average child. Very large, robust infants may require a little more, and small, delicate ones considerably less.

Overfeeding is to be particularly avoided in summer, and it is at this time that it is most likely to be done, especially during days of excessive heat, from the thirst occasioned by free perspiration. It is at such times an excellent rule with infants to diminish each meal by at least one-fourth, making up the deficiency with water, and to give water in small quantities between the feedings.\* Children, like adults, require less food in very hot

\* Under this last point I wish to call attention to an experience of Dr. David Little, of Rochester, New York, which he published in "The Transactions of the Medical Society of the State of New York" in 1884.

In an orphan asylum in his city where every previous summer had witnessed a number of deaths from diarrhoeal disease, he directed that infants should be fed at three-hour intervals during the day and should have nothing at night. Water was allowed freely at all times.

The season passed without a fatal case from diarrhoeal disease. At the close of the season he remarked to the Sister in charge that the new rules of feeding had proved beneficial. She replied, "Yes, but it did seem rather cruel to feed the infants only three times a day." These were the directions as she had understood them and as they had been rigorously carried out.

weather, but more water. Unless this rule is followed, infants cry from thirst and heat, and even those at the breast are likely to be given too much food.

*Too Frequent Feeding.*—This is usually an accompaniment of over-feeding, but not always. No more pernicious habit exists, and none more certain to set up gastro-intestinal disorder, than that of filling a large bottle with food and putting the nipple into the child's mouth while it lies in its crib or carriage, allowing it to sleep and eat alternately for the greater part of the time. The same can be said of the habit of allowing an infant to sleep at the mother's breast and nurse every time it awakens during the night,—often a dozen times.

If we would prevent gastro-intestinal disease we must attend to the hygiene and physiology of the stomach and intestines, and with these the taking of food into the stomach every hour or oftener is absolutely incompatible: there can be no such thing as healthy digestion.

Food in proper quantities, at proper intervals, with absolute regularity, and the stopping of night-feeding and nursing as early as possible, are the first essentials of healthy digestion, and fundamental principles in the prophylaxis of all intestinal diseases. We have emphasized these points, not because they are of greater importance than the one next to be discussed, but because they have been so often ignored, even when due care has been bestowed upon the selection and preparation of the artificial food.

*Improper Foods.*—The habitual use of improper articles of food is a very important predisposing cause of diarrhœal disease. Children thus fed suffer almost always from a mild intestinal catarrh.

Our experience leads us to the belief that no infant foods can compare with cow's milk for infants during the first year, and that the extensive use of all dextrin and starchy foods as substitutes during this period is to be deprecated. They do harm very often not so much from what they contain as from the elements they lack. Their direct agency in causing diarrhœal diseases has, however, we think, been rather overstated. Much more to be condemned is the miscellaneous feeding of infants with things from the table,—vegetables, meat, sweets, and other articles totally indigestible.

To be especially avoided during the second year are most vegetables, particularly beets, tomatoes, and potatoes, fruits, especially in cities and in summer, all dried fruits, all cakes and sweets, coffee, and tea. We have found no rules to avail much unless mothers are given a written list of articles allowed and forbidden during the second and third years.

In older children improper foods and feeding are not only the predisposing but in most cases the exciting causes also.

In summer stale and unripe fruits and melons should be avoided, also free indulgence in ice- and soda-water. The constant habit of lunching at all hours upon cakes, pies, candies, nuts, etc., should on no account be tolerated, nor the indulgence at meals in pastry, highly-seasoned entrées, soups, and jellies. The children in our American homes too often are

allowed to make the principal part of their meals from such food, to the exclusion of plainer and simpler articles.

There is only one way to make children desire the proper articles, and that is to prohibit absolutely all others and give plenty of plain simple food at proper intervals.

*Impure Foods.*—First and pre-eminent under this head is milk, and most important are the changes induced in it by bacteria.

More important than all else in the prevention of diarrhoeal diseases is it that rich and poor in city and in country should be supplied with pure and wholesome milk, and that they should be taught how to keep it so in their homes.

Care of cows: The stables must be clean and airy; the teats, udders, and milkers' hands must be carefully washed before milking. The cows must have open air and plenty of plain food. Milk from cows stuffed with garbage, brewery slops, etc., should not be used, nor from cows which have themselves evidence of disease on the udders or elsewhere.

Care and transportation of milk: The milk should be placed as soon as possible in tightly-covered vessels, and be disturbed as little as possible by pouring from one vessel into another. Until transported it should be kept at a temperature below 50° F. Transportation should be in refrigerator cars, and the milk should be inspected on its arrival in the city and its temperature taken. No milk should be admitted which registers over 60° F. The city delivery of milk, also, should be in carts in which the cans are kept upon ice during the summer months. The sale of milk, whether from wagons or from shops, should be allowed only by dealers licensed by boards of health, and the dealers should be compelled to keep milk at the proper temperature, about 50° F. Systematic milk-inspection should be kept up, and licenses revoked for violation of rules. None of the precautions now taken to secure against the dilution and adulteration of milk should be neglected.

The care of milk in the homes: It should not be delivered so early that it must stand two or three hours in pitchers, etc., before it is put on ice. For young children there is a great advantage here in the use of milk delivered in bottles. As soon as possible after it is received, the milk should be put into the bottles from which it is to be fed, in quantities proper for a single feeding. This practice should be followed also in the case of infants who are not fed from a bottle.

The milk is now to be sterilized, according to the directions given elsewhere in this work.

In institutions where it is impossible to sterilize all milk in separate feeding-bottles, the same thing can be accomplished with tolerable certainty by raising the milk to the boiling-point in a saucepan or a covered vessel, maintaining this temperature for thirty minutes, and then pouring it into quart bottles which have been the same length of time in boiling water, corking with cotton, and placing on ice. As an entire bottle can be used up



for a single feeding of several children, there is not the objection of having to open the bottle several times before its contents are consumed.

Among the poor and negligent, where proper directions for sterilizing cannot be carried out, the best substitute seems to be to use the bottled milk, and keep the closed bottles in boiling water three-quarters of an hour, then put on ice.

The value of sterilizing milk before feeding it to infants is established beyond the necessity of discussion here. In cities, where some of the milk is twenty-four hours old when received, and forty-eight hours old when consumed, the need is imperative. In the country, where fresh milk can be obtained twice a day from healthy cows, the same necessity does not exist. But even there it is best to strain the milk through cotton and put it when received into the bottles from which it is to be fed, cork with cotton, and place on ice. If proper care is bestowed upon the cows, nothing more is required, beyond care of utensils.

The care of bottles, rubber nipples, etc., is second in importance only to that of the milk itself. The best method of cleansing bottles we have found to be the following. Rinse with cold water, carefully scrub with brush and hot suds, fill with weak soda solution and let stand till needed for milk supply, then boil for half an hour, or bake for the same length of time in a hot oven, and cork with cotton.

The use of long rubber tubes, or tubes of rubber and glass, as attachments for feeding-bottles, should never under any circumstances be allowed. To keep these clean is almost a matter of impossibility, even for the most careful. They are held in high esteem among the poor, since when they are used an infant can be placed in its crib, the nipple put in its mouth, and the child left to sleep or eat as it wills, for hours at a time; while the other style of nipple needs the attention of some one until the meal is finished, to keep the bottle tipped so that the milk will flow.

Only rubber nipples which slip over the mouth of bottles should be used. These should be turned inside out and scrubbed at least once a day, and at all times when not in use should be kept in a solution of borax or salicylate of sodium.

What has been said of milk applies with equal force to all milk foods, gruels, broths, and infant-foods generally. Only water which has been boiled at least half an hour should be used in their preparation. Everything left over from a single feeding should be thrown away, no warmed-over messes being given. Under no circumstances should milk or any food be allowed to stand in open vessels in a living-room.

The entrance of germs into the canal is to be prevented not only by destroying by heat all those existing in milk and other foods, but also by boiling all water given to the child, by attention to the cleanliness of the child's mouth, as well as of its hands, which so much of the time are in the mouth, and, in the case of nursing infants, by cleanliness of the mother's breast and nipples; these should be washed before and after each nursing.

Another important point in the prophylaxis of severe forms of disease is early and prompt attention to all the milder derangements of the stomach and intestines, particularly during summer. The larger proportion of cases of cholera infantum and entero-colitis are preceded for some time by milder symptoms. Prompt attention at the outset is usually efficient. Too much cannot be said in condemnation of the practice of allowing a slight looseness of the bowels to go on for a week or more, simply because the child happens to be teething. Yet many mothers believe such a condition of the bowels to be not only not injurious but even positively beneficial. Such an error has cost many infants' lives.

Every gastro-intestinal derangement, no matter how slight, should receive prompt attention, with the idea that at any time severe and even dangerous symptoms may supervene.

To summarize, prophylaxis demands,—

1. Getting as many infants out of the city in summer as possible.
2. The education of the laity up to the importance of regularity in feeding, to the dangers of overfeeding, and as to what is a proper diet for infants just weaned.
3. Proper legal restrictions regarding the transportation and sale of milk.
4. The exclusion of germs or their destruction in all foods given, but especially in milk, by carefully sterilizing milk, and scrupulous cleanliness in bottles, nipples, etc.
5. Prompt attention to all mild derangements, especially in summer.
6. Cutting down the amount of food and increasing the amount of water during the days of excessive summer heat.

---

## VI. SIMPLE DIARRHOEA.

Under this head it is meant to include those cases of diarrhœa in which there is a derangement of function without anatomical changes, without fever, and without involvement of the stomach,—*i.e.*, which are not dyspeptic. With these limitations the number of cases to be included under this head is very much smaller than most writers upon the subject describe.

**Etiology.**—Predisposition is the same for this as for all other varieties of diarrhœa,—age (under two years), bad intestinal hygiene, such as bad habits of feeding and improper food, insanitary surroundings, and the warm season.

The most important special causes of this variety are those acting upon the nervous system. As such may be classed dentition, chilling of the surface, exhaustion from fatigue or other cause, and the direct effects of atmospheric heat. The last two mentioned—exhaustion and heat—are

very much more frequently associated with dyspeptic diarrhœa, yet there seems to be pretty good ground for the opinion that this is not always the case. The same may be said of menstruation and various nervous impressions upon the mother of a nursing infant.

Foreign bodies, or articles of food which act virtually as foreign bodies, such as uncooked or partly-cooked grains of rice, hominy, barley, or green corn, or green fruits,—and nuts and raisins in the case of very young children,—all these may be the cause of a simple diarrhœa. These cases are sometimes classed as instances of mechanical diarrhœa.

Certain fruits, such as the peach, pear, grape, etc., may excite diarrhœa, from the organic acids they contain or from their seeds acting mechanically.

Diarrhœa may be due to any one of the various cathartic drugs, in which the normal physiological effects have, from the susceptibility of the patient, been very greatly exaggerated in intensity or prolonged. It is extremely doubtful if any of the ordinary cathartics given to the mother ever operates upon the child's bowels through the milk.

A hypersecretion of bile is generally believed to be sometimes a cause of diarrhœa. Such cases are certainly rare.

The common habit in this country of allowing children to drink freely of ice-water may result in an attack of diarrhœa, apart from another visible cause.

**Pathology.**—In these cases we have neither intestinal decomposition nor intestinal inflammation as the cause of the symptoms. There is increased peristalsis, depending upon local irritation or of reflex origin, increased secretion, chiefly serous, and in most cases a moderate hyperæmia; this is sometimes, judging from the symptoms, pretty intense. If the exciting cause continues operative, the case may go on to intestinal inflammation.

**Symptoms.**—These may come on suddenly or gradually. If suddenly, there is usually abdominal pain preceding the diarrhœa; otherwise this is absent. There are at first one or two soft, fecal stools; then they become quite thin, and may be watery. There may be as many as eight or ten in a day. There may be restlessness in the case of infants, and at all times there is a good deal of exhaustion, and often a clammy skin from perspiration. But there is no vomiting, and the temperature is not elevated, these two negative symptoms quieting at once the apprehension that may have been felt regarding a more serious illness. The stools are not often green in infants, but are of a pale-yellow or gray color; in older children they are thin and brown or gray, and in all there is more or less odor. If the cause has been some material acting as a foreign body, this may be found in the discharges.

If left to themselves, these cases usually recover in three or four days, but they may also develop into more serious forms of intestinal disease, particularly if it be summer. If the cause is not removed, there may be frequently recurring attacks such as have been described, until a chronic diarrhœa is finally established.

**Treatment.**—These cases in the vast majority of instances are easily and promptly curable if taken in season. Opium is the sovereign remedy; but before this is given a full dose of castor oil should be administered. A teaspoonful may be given to an infant of from three to six months, a table-spoonful to a child over four years. If the cause of the diarrhoea is any mechanical irritation, this preliminary cathartic is an absolute necessity. It is a good rule in all cases. Calomel (gr. i to gr. iii) or syrup of rhubarb (ʒi to ʒiv) may be substituted for the oil, but they are less certain and less satisfactory. Five or six hours after the cathartic the opiate should be given. It is a good rule to prescribe a safe dose and order it to be repeated after each stool. The form of preparation is not of great importance: paregoric and Dover's powder are probably as good as any. For a child a year old from six to ten drops of the former or a quarter of a grain of Dover's powder may be ordered in the manner indicated. Opium stops peristalsis, and after the intestine has been emptied that is mainly what is wanted in these cases.

In cases not yielding promptly to opium alone, bismuth subnitrate may be added, but this will not often be required. The child must be kept quiet in its crib or carriage, and on no account be allowed to run about until it is quite well.

In the matter of diet almost nothing must be given for twelve to twenty-four hours, and then for two or three days only food which can be almost entirely absorbed. The point is to keep the intestines as quiet as possible until the irritation has subsided. Barley-water, thin broth, and whey may be used, but no milk, unless it be breast-milk. Careful feeding must be kept up for a week, to prevent a recurrence of the diarrhoea. If it is summer, this is imperative.

A proper management of these cases of simple diarrhoea is one of the most important prophylactic measures against the severer forms of intestinal disease. On no account should these cases be neglected because the child happens to be teething.

---

## VII. ACUTE MYCOTIC DIARRHOEA, OR DIARRHOEA OF BACTERIAL ORIGIN.

**Synonymes.**—Acute gastro-intestinal catarrh, Cholera infantum, Summer complaint, Summer diarrhoea, Infectious diarrhoea.

It has seemed to me that our knowledge of this class of cases has advanced far enough to make a change from the time-honored "summer diarrhoea" not only justifiable but even necessary. It should be kept before our minds constantly that the most potent factors in producing this disease—or, rather, these diseases—are micro-organisms. The grounds upon which this opinion rests have been already gone over pretty fully in the section on the relation of bacteria to diarrhoeal disease.

The lesions have been described under the heading of acute desquamative catarrh. It has seemed to me that the clearest understanding of these cases is reached by considering the process as not exactly inflammatory, but rather an acute decomposition or fermentation in the gastro-intestinal tract which is preliminary to inflammatory lesions.

Two distinct forms are met with: (1) acute dyspeptic diarrhœa; (2) cholera infantum.

#### I. ACUTE DYSPEPTIC DIARRHŒA.

**Etiology.**—All the causes enumerated in the section on etiology are important here. This variety includes the greater number of the cases of summer diarrhœa, or at least forms a stage in these cases. It is most frequently the initial stage, but it is sometimes the final one. We need not do more here than summarize the causes summer heat, artificial feeding, bad habits of feeding, improper foods, impure milk, bad surroundings, and city residence, as the etiological factors.

**Pathology.**—Dyspeptic diarrhœa is a diarrhœa set up by undigested food in the intestine and by the putrefactive changes in such food. If the resistance of the patient is great, the cause a transient one, and the case properly managed, there is only functional disorder, and in a few days there may be complete recovery. In a susceptible patient, where the exciting cause continues operative, or when improperly managed, the process continues, and anatomical changes are produced,—*i.e.*, the case becomes one of gastro-entero-colitis in which the dyspeptic diarrhœa was the initial stage.

**Symptoms.**—Two forms are met with: first, a mild form, with a gradual onset, with little or no fever, and usually without any gastric disturbance; secondly, a severe form, in which the onset is sudden, usually attended by high temperature and by vomiting.

In the mild form there may be for the first few days no symptoms except the diarrhœal discharges, or the child may be peevish, fretful, especially so at night, and may seem generally out of sorts. From the fact that the general symptoms are so few, cases of this kind are often allowed to go on for several days by mothers under the common belief that the children are “only teething.”

The stools are green or yellow, thinner than normal, and contain masses of undigested fat and occasionally curds. Sometimes they are of an offensive odor, but frequently not; there are usually from three to six daily. After a few days they contain in most cases mucus in smaller or larger quantities. Fruits or starchy foods appear in the stools almost unchanged. The appetite may be normal, but is usually impaired, and may be almost lost after a few days. The tongue shows generally a thin white coating; the mucous membrane of the mouth may be congested, or in very young infants covered with thrush. Sometimes the general health will not be noticeably affected for two or three weeks. Often after a few days the infants become pale, lose flesh, their limbs become soft and flabby, they lose

their spirits, and the scales show a loss of one or two pounds in a week. If proper treatment is instituted and the cause is removed, there is noticed an improvement in the character and frequency of the stools, the mucus disappears, the color becomes a pale yellowish green and finally yellow, the appetite returns, the strength and spirits improve, and the children recover after an illness of from four to fourteen days. Occasionally the condition may last for a longer time. It is very common to have an occasional bad stool after these have been generally good for a day or two, but this is of no significance. Relapses are very easily brought on by slight irregularities in diet, especially overfeeding. In the cases which do not run this favorable course we may have at any time the supervention of acute severe symptoms, and the case may become one either of cholera infantum or of entero-colitis. This change often takes place with great suddenness, and is frequently coincident with a few days of very hot weather or follows some gross dietetic error.

A third termination, but not so common as either of the preceding, is a continuance of the mild symptoms with exacerbations and remissions during the entire summer season, until the cool weather of autumn comes.

These cases may be cut off at any time by any intercurrent disease, particularly by pneumonia.

Infants suffering from athrepsia not uncommonly die from a very slight exacerbation of the intestinal symptoms, the autopsies revealing no other cause of death.

In the cases developing suddenly the clinical picture is quite a different one. The attack may begin abruptly in a child apparently healthy, or there may have been for some days symptoms of slight intestinal derangement. If an infant, it is restless, cries much, sleeps but a few minutes at a time, and seems in distress. The skin is hot and dry, the temperature runs up rapidly to 102° or 103° F., often to 105°, the abdomen is distended and hard, the legs are usually drawn up, and all the symptoms indicate the onset of some grave disorder. The nervous symptoms in some cases are very severe, and even convulsions may occur. There may be great thirst, so that everything offered is taken eagerly, or, on the other hand, everything may be refused.

Usually in the course of from four to six hours after the onset the gastrointestinal symptoms come on. There is first vomiting, which may be of undigested food taken many hours before. If this was milk it frequently comes up in hard curds and very sour. After the stomach has been apparently emptied, mucus and serum are ejected in small quantities after much retching, and sometimes the vomiting is bilious. The vomiting is easily excited by the giving of food or drink.

Diarrhœa soon follows,—first feculent stools, then great bursts of flatus, with the expulsion of very thin yellowish stools of a terribly offensive odor. Four or five such discharges may occur in as many hours. In other cases the stools are gray, green, or greenish yellow, sometimes brown; but char-

acteristic features are the amount of gas expelled, the colicky pains preceding the discharges, and the sickening odor.

In a considerable number of the cases this free evacuation of the bowels is followed by a fall in the temperature and subsidence of the nervous symptoms, and the child falls asleep, to be awakened for an occasional stool after a few hours.

The prostration is often great in the beginning, but not of long duration. Under favorable circumstances and with proper management, the case, after twenty-four or thirty-six hours of severe symptoms, may go on to a rapid convalescence. The movements continue abnormally frequent for three or four days, but gradually assume their normal character, and a prompt recovery can usually be predicted.

Such are the cases in which the brilliant results of treatment are obtained, and often reported as cures of "cholera infantum." The chief features contributing to such favorable results are a good constitution on the part of the child and the ability to regulate the feeding afterwards.

If circumstances are not so favorable, if the child is cachectic and badly cared for, the fall in the temperature is often only a temporary one; the vomiting may not recur, but the diarrhœa keeps up, the stools gradually changing in character, becoming less offensive perhaps and not so fluid, but with mucus added and occasionally streaked with blood; in other words, becoming more and more of the character seen in entero-colitis.

The general symptoms follow the same course: the first profound impression made upon the nervous system subsides, and the children become pale, worn, prostrated, and exhibit the symptoms described in the section on entero-colitis.

In some cases there may be a series of such attacks separated by a week or ten days, the stools never becoming quite normal between them, but all other symptoms being absent. It may be not until the third or fourth attack that the entero-colitis is finally established.

In children over two years old there are some features which differ from the cases described above as occurring in infants.

Here they usually follow the ingestion of some indigestible article of food, such as green apples, unripe berries, etc., or milk which has been tainted from exposure. Vomiting here does not come on so readily as in infants, pain is a much more prominent feature, and the temperature is, as a rule, lower.

Such cases, although beginning with severe symptoms, usually make good recoveries: there is much less likelihood of their running on to inflammatory forms of diarrhœal disease than in the case of infants.

**Diagnosis.**—The diagnostic points about the acute attacks are their sudden onset, their severe symptoms, their brief duration, and usually their favorable termination. They are violent, often alarming, but brief, convalescence frequently being established in two or three days.

Dyspeptic diarrhœa is to be differentiated from cholera infantum and

gastro-enteritis or entero-colitis, and in its onset from the general diseases malaria, scarlatina, pneumonia, and tonsillitis.

From cholera infantum it is distinguished by its milder character,—prostration being less, temperature usually lower, nervous symptoms less pronounced,—but particularly by the stools: the large serous neutral or alkaline stools belong only to cholera infantum. Although nearly every case of cholera infantum is preceded by a dyspeptic diarrhoea of greater or less severity, the former is not to be regarded as simply a more severe form of acute dyspeptic diarrhoea.

To differentiate these cases from those of inflammatory diarrhoea is impossible for the first day or so. The onset is often identical, and we cannot say at once whether they are going on to the development of inflammatory changes or not. The subsidence of fever and all severe symptoms at the end of twenty-four or thirty-six hours shows that we have had only a putrefactive process with functional derangement; while a continuance of severe symptoms, and especially of the fever beyond the second day, is usually evidence of inflammatory changes.

The sudden development of high fever, prostration, vomiting, and even diarrhoea, is common to very many diseases of infancy, especially to malaria, pneumonia, scarlatina, and tonsillitis. It is always difficult, and very often impossible, to say at the outset whether we have anything more than a dyspeptic attack to deal with. The symptoms of the latter are often so severe that it is difficult to believe the sole cause to be the gastro-intestinal disorder.

Tonsillitis is revealed by an inspection of the throat. Before excluding scarlatina we must wait until the time for the rash. The question of malaria is a difficult one to decide, and may require an observation of the temperature for two or three days. Pneumonia can usually be recognized by the physical signs, if it is looked for.

In general, marked improvement in the gastro-intestinal symptoms with a continuance of the general ones—fever, prostration, etc.—drives us to seek another explanation for them. More than once I have seen pneumonia overlooked until the third or fourth day because of the early prominence of gastro-intestinal symptoms.

It should be remembered that any acute disease in summer is likely to present gastro-intestinal symptoms, especially at its onset.

**Prognosis.**—There are very few cases of acute dyspeptic diarrhoea that prove fatal, except among children already suffering from athrepsia. It is not uncommon among such children in institutions to have fatal cases of diarrhoea which have never presented any choleraic symptoms, and which do not show at autopsy the lesions of entero-colitis. The explanation seems to be that such feeble constitutions are overcome in the first stages of intoxication and prostration. It is a surprise to see with how few symptoms such children succumb.

In all cases suffering from athrepsia any diarrhoeal attack may prove fatal, and a guarded prognosis must be given.



In other cases our prognosis resolves itself into this question: what are the probabilities that the existing attack will go on to the development of inflammatory changes?—*i.e.*, will it become a gastro-entero-colitis, or an entero-colitis? In answering this there must be considered the child's constitution, the manner in which it has been fed, the previous state of its gastrointestinal canal, its surroundings, how early the case comes to hand for treatment, and how well treatment can be carried out. If the child has been rather delicate, has been badly fed, has suffered from frequent previous indigestion and mild diarrhœa, if its surroundings are bad, if the attack has been allowed to run on two or three days before interference, and if proper dietetic and hygienic treatment cannot be carried out,—all these circumstances make it likely that the attack will become an entero-colitis, and the likelihood is generally just in proportion to the number of the factors which are present.

Manifestly, all these conditions are worse in very hot summer weather.

Much depends, then, upon early energetic treatment and one's ability to remove the exciting causes. The prognosis is worse in patients suffering from previous disease, such as pertussis or pneumonia.

**Complications.**—The complications are mainly thrush, seen mostly in very young infants, and erythema of the buttocks and thighs. Both of these are referred to in detail under entero-colitis.

**Treatment of Dyspeptic Diarrhœa.**—The subject of prophylaxis has been discussed at length in the general chapter upon that subject. Almost everything there said will apply to the cases under discussion.

**HYGIENIC TREATMENT.**—If the attack occurs in summer and does not yield at once to the management employed, a *change of air* should be made, wherever it is possible. Whether the child be sent from the city to the seashore or to the mountains is not so important as it is that it shall go where it will be likely to have the best food and the best local surroundings. A change is the main thing. In the country or in small towns a change is not so necessary, and, in fact, is not generally required unless the condition becomes somewhat chronic. In such cases more can sometimes be accomplished by a change of air than by all other means.

Among the tenement-house children of New York much good is done by the day excursions upon the salt water. Too often, however, only temporary benefit results, and the cases relapse on their return to their homes.

*Fresh air* is of the utmost importance to all diarrhœal cases in summer. No matter how much fever or prostration there may be, these cases always do better if they are kept out of doors, except possibly during three or four hours in the middle of the day on very hot days. Nothing is so depressing as close, stifling apartments. Children should not be allowed to walk, even if they are old enough and strong enough to do so. They can be kept out in carriages, in perambulators, or in hammocks. Quiet is also important.

The *clothing* in summer should be the lightest flannel to be obtained: a single loose garment is preferable. A thin layer of linen or muslin can be put next the skin where there are much perspiration and a sensitive skin.

At the sea-shore and in the mountains especial care should be taken to see that sufficient clothing at night is supplied.

*Bathing* is of very great advantage to allay restlessness, as well as for cleanliness and the reduction of temperature. For the first purpose a sponge-bath of alcohol-and-water or vinegar-and-water is sufficient. For the reduction of temperature only the tub-bath is to be relied on. If the temperature continues above 102° F. or near that point, systematic bathing must be carried on. The temperature of the bath should be nearly 100° F. when the child is put into it, and should then be gradually reduced to 80° or 85° by adding ice. The bath should be continued for from ten to thirty minutes, according to the amount of reduction effected, and repeated from two to eight times daily, according to the requirements of the case. The bath thus used has generally a very quieting effect, which would be entirely lost by the terror and excitement caused by putting an infant suddenly into a cold bath.

Scrupulous cleanliness should be secured in the child's person and clothing. Napkins should be removed from the child and from the room as soon as soiled, and placed in a disinfectant solution. Frequent washing of the buttocks and genitals, together with the irritation from the discharges, often causes excoriations. If these exist, plain water should not be used for bathing, but bran-water should be substituted.

DIETETIC TREATMENT.—Dietetic and hygienic treatment in this class of diarrheas is of very much more importance than the use of drugs. It is of the first importance to remember that during the stage of acute febrile symptoms digestion is practically arrested. To give food requiring much digestion, manifestly, can do only harm. In the stomach it produces irritation until it is expelled by vomiting or passes into the intestine and adds to the fermenting masses there present and aggravates the existing disorder.

In nursing infants the breast must be withheld so long as a disposition to vomit continues, and no food whatever given for from six to twelve hours. Thirst may be allayed by rice-, barley-, or toast-water or mineral waters given cold and frequently but in minute quantities. Stimulants may be added to these if required. If these are refused or vomited, absolute rest to the stomach will do more than anything else to hasten recovery. After the stomach has been quiet for ten or twelve hours it is generally safe to allow the child to be put to the breast, tentatively. The intervals of nursing should not be shorter than three hours, and the amount allowed at one feeding should not be more than one-half or one-third the usual meal. The remainder may be made up by mutton or chicken broth or by thin barley gruel. The amount of breast-milk allowed may be steadily increased, so that in three or four days the breast may be taken exclusively. If there

is any reason to suspect the breast-milk as a cause of the attack, such as menstruation, pregnancy, or some nervous influence—exhaustion, grief, or fright—on the part of the nurse, we must stop the nursing temporarily or permanently, according to circumstances, and secure a wet-nurse or begin hand-feeding.

In infants just weaned the same plan is to be followed and a return to the breast made if possible.

In young infants who are being hand-fed, if the attack be a severe one and in summer, a wet-nurse should be secured wherever this is possible. In case a wet-nurse is out of the question, we are brought face to face with one of the most difficult problems in the management of diarrhœa: how to feed artificially a young infant suffering from dyspeptic diarrhœa, either acute or subacute.

When the exact nature of these dyspeptic diarrhœas is better understood, when the life-history of the various forms of bacteria which set up putrefactive processes is known, and we are able to say from clinical symptoms which process we are dealing with in a particular case, we may approach to something like scientific accuracy in our dietetic treatment. But until that time comes we must be guided by experience alone.\*

First, as to the use of cow's milk. While nursing infants should generally be put back upon the breast as soon as vomiting is permanently controlled, it will not do to follow the same rule with respect to cow's milk. This must generally be withheld in all forms until all acute symptoms are past. The experience of the profession is nearly unanimous upon this point. Our reliance at this stage is upon egg-water,† the animal broths,‡—chicken, mutton, and beef,—the expressed juice§ of beefsteak, beef peptonoids,||

\* Escherich,<sup>32</sup> from his bacteriological studies, has laid down the following rules for feeding, the practical value of which has not yet been proved, but which seem worthy of a careful trial. If albuminous decomposition with very foul, offensive stools exists, these articles should be withheld from the diet and carbohydrates given, dextrin foods, sugars, etc.; if an acid fermentation is present, with sour but not offensive stools, carbohydrates are to be withheld, and albuminous foods given, such as animal broths, peptones, etc. Milk he classifies with the carbohydrates, since in its decomposition it is the sugar of milk and not the casein that is usually broken up.

Baginsky<sup>33</sup> has followed out this plan of feeding, but did not find it satisfactory, the character of the stools not being a sufficient guide to the nature of the process in the intestine.

† *Egg-Water*.—The white of a fresh egg, a pint of cold water (previously boiled), a teaspoonful of brandy, and a small pinch of salt.

‡ *Animal Broths*.—One pound of finely-chopped lean meat (chicken, mutton, or beef), one pint of cold water (one and a half pints for young infants); put in a glass jar, and let stand four to six hours on ice, covered. Cook three hours in a closed jar over a slow fire, strain, cool, skim off fat if any rises, season with salt, and feed warm or cold. It may be cleared with egg if desired.

§ *Beef Juice*.—Thick steak, broiled rare, juice pressed out with meat- or lemon-squeezer, season.

|| Of the beef peptonoids sold in the market, Carnrick's liquid preparation is usually easiest given and best borne. Of the various meat extracts, Rudisch's "sarcopoptones."

barley- and rice-water, and the dextrin foods, such as Liebig's, Horlick's, or Mellin's, made without milk, or "flour ball" \* and water, or wine whey. †

After the first two or three days, when the symptoms of acute fermentation have subsided and the stools are less frequent, we may add cow's milk to the diet, tentatively. It is not enough that milk be sterilized, for this procedure, although of very great value as a prophylactic measure, has but little curative value.

There are three methods of administering milk. The first is by free dilution,—at least four parts of plain water or barley-water to one of milk; in many cases milk given in this way will be found to agree perfectly, and nothing more will be required. As the case progresses, the proportion of milk can gradually be increased. The second is the well-known method of partial peptonization by the use of Fairchild's tubes, the process being continued from six to fifteen minutes, and not allowed to go on to develop the bitter taste. With this I have been very frequently disappointed. It has failed much more often than it has succeeded.

The third method is the same process continued for *two hours*, at the end of which time all the casein has been digested. Lemon-juice can now be added to cover up the bitter taste, without causing any curd; and with the addition of a little sugar a very palatable food is produced. It is readily taken, all the more so usually from its sour taste. I have used it with the happiest results. It certainly deserves more attention than it has received.

With milk, as with every other food, its effect upon the character of the stools must be our guide in its use.

Some of the forms of fermented milk, such as koumys, kéfir, and matzoon, serve a very useful purpose, and can often be retained upon an irritable stomach when almost everything else is vomited. Young infants will usually take them eagerly at first, but soon tire of them and finally refuse them altogether.

In the diarrheas of older children which have for their most common cause the too early use of solid food or the use of improper articles of food, nothing succeeds so well in most cases as a milk diet. The milk should be boiled, and one-third lime-water added at first. Everything in the shape of food is, of course, to be withheld while there exists an inclination to vomit.

*General Rules regarding Feeding.*—No food whatever is to be given upon a very irritable stomach. Articles requiring the least digestion and leaving the smallest residue should next be tried. Food prescriptions must

\* *Flour Ball.*—Two or three pounds of wheat flour, tied in a bag and boiled continuously for twelve hours; the outer shell is scraped off, and the inner, yellow portion (mainly dextrin) grated and used to make a thin gruel.

† *Wine Whey.*—A teaspoonful of wine of pepsin, one pint of milk at a temperature of 110° to 120° F.; let stand till firmly coagulated. Break up curd and strain. Add sherry wine in proportion of one to four or one to six. Feed cold.

be made with the same care and exactness as prescriptions for drugs ; for in most cases they are more important. Quantity and frequency must be definitely stated, as well as the articles ordered. Directions should be given in writing, or they will be half forgotten before the physician is out of the house.

A practical acquaintance with the proper appearance and taste of every food ordered is absolutely indispensable.

There are four common mistakes in feeding in diarrhœa which are the cause of many a failure : feeding too much at a time, feeding too frequently, trying too many articles at once, and changing before a thing has been really tested.

For a single feeding the quantity allowed will vary according to the tolerance of the stomach ; but it should always be much less than is given in health, usually from one-fourth to one-half that amount until the child demonstrates his capacity to digest more. It is rarely necessary to nurse or feed a sick child oftener than every two hours. Of course, in cases of great prostration stimulants may be required much more frequently. We have only to imagine how an adult with a sick stomach would feel to be offered something in the shape of food every five or ten minutes, in order to appreciate the disgust for all food which soon overtakes an infant who is similarly besieged.

By trying four or five articles at once and changing the diet every day or oftener, the list is soon exhausted, and it is impossible to say which of the articles was at fault.

Still, after all has been said, it is a difficult problem to feed these children under three years of age, capricious as they are by nature and still more so by education ; and the judgment and tact of the physician are taxed to their utmost. We must have many resources ; for a diet which one child takes well, the next disdains utterly. The best method is to select from a list of articles of accepted value such as circumstances will permit, and such as are most likely to be properly prepared, and try them patiently, one after another, until one is found which the child under treatment will take and which agrees with him.

**MEDICINAL TREATMENT.**—In these cases it must be borne in mind that we are not treating an intestinal inflammation, although such may be the ultimate result of the process beginning as a dyspeptic diarrhœa. Essentially here our treatment is to be directed against the process of fermentation or putrefaction, and towards the restoration of the normal gastro-intestinal functions which have been deranged.

The indications are (1) to evacuate the fermenting masses from the stomach and intestine ; (2) to combat the process of decomposition by drugs and proper food ; (3) to restore healthy action by intestinal hygiene ; (4) to treat symptoms and complications.

It is not often in acute cases that we are obliged to resort to therapeutic measures to empty the stomach, as the vomiting is usually sufficient for that

end. In cases of continued retching, where but little is ejected, it may be that larger curds than can be easily got rid of are present. Emetics, although they serve a very useful purpose in older children, are not to be advised in young infants.

In such cases the best and most certain measure is to wash out the stomach. In acute cases I think its use should be limited to those of uncontrollable vomiting. The largest size of flexible rubber catheter is the best instrument, and plain lukewarm water probably the best fluid. The water is allowed to flow in and out freely until it comes away quite clear. Stomach-washing may be practised without danger in the youngest infants. It is a simple procedure: in fact, it is exceedingly difficult to pass the catheter anywhere else than into the œsophagus, as any one familiar with intubation will appreciate. A single washing in most cases is all that is required. It is never necessary to repeat it more than once daily. In certain cases this is probably of more value than all else.

After the stomach has been emptied, a small quantity of some medicinal solution may be left in the organ if desired. In Germany those most employed are a three-per-cent. solution of benzoate of sodium and a half-per-cent. solution of resorcin. No food whatever is given for two to four hours, and then only the blandest articles in small quantities.

Stomach-washing has long been in use in Germany, but has not yet been so much employed in this country as it deserves to be. It is not in the class of cases under discussion that its greatest value is seen. From personal experience I am led to think highly of it. (For a full account of the literature of the subject see the articles of Ehring<sup>34</sup> and Epstein.<sup>35</sup>)

As a substitute for stomach-washing, some writers have advocated the practice of allowing infants to drink freely of fluids, especially ice-water, which is generally taken readily, although almost immediately vomited. This seems a very uncertain way of doing what can be so much better done by stomach-washing. It certainly acts in many cases to intensify and aggravate the irritability of the organ.

To empty the intestines is an indication in every instance, no matter whether or not any indigestible food has been taken. This may be accomplished by cathartics or by intestinal irrigation.

Of the cathartics, castor oil and calomel are greatly superior to all others. Calomel has the advantages of ease of administration, of its favorable effect upon vomiting, and of its antifermentative as well as purgative action. One or two grains of the tablet triturates given dry upon the tongue are sufficient for a child under two years. Unless the stomach is upset, I prefer castor oil in most cases, as it sweeps the whole canal, causes little griping, is very certain, and its after-effects are constipating. A child over a year old ought to take two teaspoonfuls, which may be given clear with a few drops of brandy dropped over it, or in an emulsion. It is not often vomited when given plain. To older children it may be given suspended in soda-water with some syrup of orange or sarsaparilla. It

is important that a full dose be given. The initial cathartic dose of oil, almost complete abstinence for twenty-four hours, and very careful feeding after that time, suffice to cure a very considerable proportion of these cases.

Only cathartics can be employed to evacuate the small intestine, while for the colon we may use, in addition or instead,—

*Irrigation of the Intestine.*—This has been now so long practised, both in this country and in Germany, that its value is well established. To be effectual, the water must reach the ileo-cæcal valve: it cannot be expected to do more. Attention to detail is necessary for success. The infant is placed upon the back, with hips elevated, and the water introduced through the largest size of a flexible rubber catheter or a rubber rectal tube of the same size, which is passed into the colon,—if possible, beyond the sigmoid flexure, as in that case the intestine above is readily filled. At least eight inches should be introduced. The catheter is attached to the nozzle of a fountain syringe, the bag of which is held three or four feet above the patient. During the introduction the water should be allowed to flow, as thus the intestine is distended a little in advance of the catheter, which greatly facilitates the process. The passage of the water into the colon high up is also aided by abdominal manipulation. To be certain that the water has reached to the cæcum we must have at least a pint in the colon at once for a child of six months, and a quart for a child two years old. (This I have found from experiments on the cadaver.)

We can usually see the outline of the colon when distended. Difficulty is experienced in certain cases in getting any considerable amount of water into the intestine at once. This is generally because the catheter has not been carried high enough into the intestine. Pressing the folds of the buttocks together is usually sufficient to secure retention. If not, a bandage rolled round the catheter until a roller is formed an inch and a half in diameter makes a good obturator when pressed against the anus.

Irrigations need not be repeated frequently, once in twenty-four hours—or twice, at most—being sufficient, provided they have been thoroughly made. They should be made by the physician, or at least under his personal supervision.

All sorts of solutions have been used. Carbolic acid should never be employed in any strength, from the danger of poisoning. I have known of one death from this cause. Bichloride solutions are of doubtful advantage. Here, as in the case of the stomach, it is the amount of fluid injected, not the character of it, that is important. The object is to flush the large intestine (as one washes out an abscess) thoroughly. At least a gallon should be used for a single irrigation, it being allowed to flow in and out till it comes away almost clear. It may be returned through the tube or alongside of it.

As the intestine is not, like the stomach, accustomed to plain water, a normal salt solution of one drachm to a pint of boiled water is less irritating, and should be preferred. If there is an abundant secretion of rather

thick mucus, a solution of borax of the same strength may with advantage be substituted for the saline solution.

The injection of astringent solutions is not called for in acute dyspeptic diarrhœa. They will be referred to under entero-colitis.

The temperature of fluids used for injection is still a matter of discussion, some writers preferring ice-water, others water at 70° or 80° F., still others preferring lukewarm water. My own preference is for the medium temperature, except in cases where there is very high fever, when the colder solutions have a decided advantage. They should be allowed to flow out freely.

*Antiseptic Drugs.*—Since the recognition of the fact that putrefactive processes are at the bottom of this class of diarrhœas, the drift of opinion and practice has been towards the use of drugs which check the growth of bacteria. Almost every drug which is known to possess such power has been advocated in some quarter. Most of these have been used empirically, without any careful consideration of the nature of the fermentation going on in the particular case in which they were given, and ignoring the fact that any other process than that of fermentation existed in the intestine. Hence, as we might expect, disappointment in results has followed.

What may reasonably be expected of antiseptics? Those which are freely soluble are not likely to do more than affect the stomach and the upper portion of the small intestine. Those which are slightly soluble may affect the stomach and the greater part of the small intestine. Only insoluble drugs can be depended upon to reach the large intestine in any considerable quantity.

It would be of great practical assistance in therapeutics to know not only the nature of the putrefactive process, but also where it is most actively going on. The symptoms indicate that it usually begins in the stomach,—i.e., epigastric pain, distention, and vomiting before diarrhœa and intestinal symptoms. This is what might be expected in case the exciting cause were introduced with the food, which we believe to be usually the fact. There seems to be a direct extension from above downward, as bacteria and decomposing masses are carried along by the peristaltic movements of the intestine. I have found in autopsies upon diarrhœal cases that comparatively few bacteria are present in or upon the mucous membrane of the jejunum; and Escherich found in health that normal bacteria are scanty in the upper part of the small intestine, while very numerous below. The explanation he believes to be the very rapid peristalsis and abundant secretion of this part of the intestine. Nothnagel, from careful experiments, estimates that in health only two hours are required for a substance to traverse the small intestine. We know that in disease both peristalsis and secretion are usually very much increased. These seem to sweep the contents of the upper intestine, including bacteria, into the lower part of the canal; and here it is—in the lower ileum and the colon—that the most active and continuous decomposition is going on. Further sup-



port on this point is given by the fact that in entero-colitis the lesions are usually limited to the lower ileum and the colon.

A consideration of these points shows why so many antiseptic drugs advocated at first enthusiastically have been found with a larger experience to be worthless, because they probably never reached the seat of trouble.

The drugs which can be relied upon to influence decomposition in the lower ileum and the colon must be insoluble, and must be capable of being administered in large doses. Those which have this reputation are naphthalin and bismuth.

Naphthalin may be given in two- to four-grain doses hourly, either in suspension or rubbed up with sugar dry upon the tongue. While the taste is not disagreeable, the odor is intensely so. After thorough trial, I have discarded it. Although it does seem to possess a certain degree of value, it is greatly inferior to bismuth. In the proportion of one to two hundred, both Baginsky<sup>33</sup> and Vaughan<sup>13</sup> found it valueless outside the body in restraining putrefaction.

Bismuth has the advantages of ease of administration, and of possessing astringent as well as antiseptic properties. The salicylate has been lately brought to notice again by Escherich and Ehring, but to my mind it is greatly inferior to the subnitrate, chiefly because of the very much smaller doses (gr. i to gr. iv) in which it must be given. The subnitrate is best given in suspension in mucilage with a little spirit of chloroform or brandy: *e.g.*,—

R Bismuth. subnit., gr. x;  
 Mucil. acaciæ, ʒi;  
 Spts. vini Gall., gtt. iiii to v.  
 Miscæ.  
 Sig.—One dose.

To be efficient it must be given in large doses,—*i.e.*, two to three drachms daily to a child a year old. It always blackens the stools. No remedy in these cases has held its place during the last ten years, it is safe to say, so firmly as has bismuth.

Iodoform may be given in powder in doses of from two to four grains every two hours to a child a year old. It has not been extensively used, and testimony as to its value is still conflicting.

Of drugs which may be expected to act upon the greater part of the small intestine there are two,—calomel and salol. This use of calomel is quite distinct from that as a cathartic already mentioned. This drug has the advantage of allaying vomiting as perhaps no other drugs of the antiseptic class do, and it seems to act best in cases where the stomach is specially involved. The most beneficial effects are generally obtained from it when it can be given during the first day of the illness. It is not of much use to continue it for more than two days at a time. The tablet triturates are the best form of administration, and from one-twelfth to one-sixth of a grain every hour to a child a year old the proper dose and the best interval.

Gray powder may be used in the same way in half-grain doses, with similar effect.

Salol, there is pretty good reason to believe, is decomposed in the intestine into carbolic and salicylic acids. It is of unquestioned value in these cases, although its first advocates, Goelet,<sup>36</sup> Osborne,<sup>37</sup> and others, have certainly overestimated its efficacy. It is best given in suspension in doses of two or three grains every two hours to an infant a year old.

Freely soluble antiseptics cannot be expected to do more than act on the stomach and the first part of the small intestine: their chief effect must be in the stomach. Whether it is necessary that these substances be given in quantities sufficient to control bacterial growth altogether, as shown by their behavior outside the body, or whether the inhibition to such growth which much smaller amounts produce is sufficient for practical purposes, we cannot yet say positively. Certain it is that there are few if any drugs which can be tolerated in the stomach in a quantity sufficient to disinfect a similar mass outside the body, when the organ is already disturbed by disease.

It appears probable that what is required practically is to retard the bacterial growth, and that this can be done by smaller amounts. The drugs of the class mentioned which experience so far seems to show to possess real value are benzoate of sodium, resorcin, creasote and carbolic acid, salicylic acid and its soluble salts (the salicylate of sodium seems to be decomposed into salicylic acid), and certain acids, especially hydrochloric and lactic.

Benzoate of sodium is used largely in Germany, where it is recommended by the best writers, but not to any great extent in this country. It can be given in doses of from half a grain to two grains. Larger doses are objectionable, according to Baginsky. The advantage claimed for it is that it is not likely to disturb the stomach.

Resorcin has been widely used in all parts of the world. While strongly antiseptic, its toxic properties should be remembered, and it must be used somewhat cautiously. It may be given in doses of from one-fourth of a grain to one grain, in solution.

Salicylate of sodium has been in my hands more satisfactory than any other of the drugs of this group. It is to be given in doses of two or three grains every two hours to a child a year old. It should always be largely diluted, preferably in the food. The calcium salt is preferred by some writers. To answer the objection raised in some quarters, that the salicylate of sodium is not an antiseptic and does not act as an antiseptic in the intestines, we quote the experiments of Vaughan,<sup>13</sup> who found that in the proportion of one to two hundred in milk it prevented the development of an active poison which had been added. Proper control experiments were conducted. It seems likely that all these salts act by being decomposed in the stomach, setting free salicylic acid.

The bichloride of mercury is still used by many, but in my hands it

has been very unsatisfactory. Carbolic acid and creasote were much in vogue ten years ago, and they certainly possess real value.\*

There is another point of view from which the use of antiseptics in the stomach and intestines is to be considered,—viz., the effect of these drugs upon digestion. Experiments made in artificial digestion outside the body cannot be taken as representing exactly conditions existing in the organs, particularly in disease. Furthermore, results from experiments so far made are somewhat conflicting, and hence not altogether to be depended upon. They show, thus far, that almost all the substances here included as antiseptics, with the notable exceptions of calomel and bismuth, have a considerable effect in retarding peptic digestion. This objection should not deter us from prescribing any drugs the use of which practical experience has shown to be valuable.

A careful review of this whole subject from both a theoretical and a practical stand-point brings us to the conclusion that asepsis is better than antiseptics; asepsis being taken to include thorough cleansing of the canal, and the administration of foods free from germs and so selected as to be as completely absorbed as possible, leaving but a small residue. To this must be added pure air.

*Acids.*—The use of acids in this class of diarrhœas has been advocated, for the following reasons:

(1) Moncorvo<sup>38</sup> has found a notable diminution in the amount of hydrochloric acid in the stomach.

(2) Lesage<sup>9</sup> took the reaction of the intestinal tract in fourteen autopsies made within forty minutes after death: the only parts constantly acid were the transverse colon and the descending colon. The small intestine was neutral. It is a well-known fact, confirmed by several observers, that the small intestine in healthy infants upon an exclusive milk diet is acid throughout.†

(3) Pfeiffer's<sup>27</sup> experiments appear to prove that the green stools which form so characteristic a feature of a large number of these cases are associated with alkalinity of some part of the intestinal tract. (See green stools, *ante*, p. 97.)

(4) Acids have been recommended as antiseptics on account of their well-known power in checking bacterial growth. The acids most widely used have been hydrochloric and lactic. The latter is advocated by the French writers to be given in half-teaspoonful doses of a two-per-cent. solution, administered every half-hour to every four hours according to the severity of the symptoms. It is recommended to be given about twenty minutes after feeding. I have never been able to give much more than one-fourth the doses recommended, and even then vomiting was often excited.

\* For other antiseptics and their use in diarrhœa, see "Antiseptic Treatment of Summer Diarrhœa," by the writer, *New York Medical Journal*, January 29, 1887.

† Escherich,<sup>15</sup> p. 157.

My own experience leads me to prefer hydrochloric acid, of which from half a minim to five minims of the dilute acid may be given every two hours, well diluted. Neither of these acids should be given with milk unless the latter has been completely peptonized.

The relative value of acids we are not yet able to state, from the conflicting reports regarding them: on theoretical grounds they seem to be indicated, and practical experience has shown that in certain cases they are especially valuable. I have found them most useful in the subacute cases with undigested food in the stools, and particularly when combined with pepsin, but in acute cases they have been disappointing.

*Alkalies.*—Lime-water, magnesia, and chalk mixture serve a very useful purpose when there is acid fermentation of the stomach, but their effect upon the intestine is rather doubtful and uncertain.

*Astringents.*—The vegetable astringents containing tannin, such as kino, catechu, etc., were in former times largely used for this class of diarrhoeas. My own experience accords with that of many recent writers in attributing to them little or no value; while the disturbance of the stomach they so often produce when given in large doses makes them in many cases positively injurious.

Of the mineral astringents, with the exception of bismuth, which has been referred to under the head of antiseptics, scarcely more can be said. They cannot be given in doses sufficient to produce any local effects without doing harm.

*Opium.*—While required in some form or quantity in almost every case, as it is frequently given opium does much more harm than good. In order to use it intelligently, and hence efficiently, it should be remembered just what the action of opium on the intestine is. Nothnagel<sup>21</sup> (p. 69) has shown, as a result of his carefully-conducted experiments, that its principal action is as a stimulant to the inhibitory nerves of the intestine, thus checking peristalsis; its action in diminishing secretion is regarded as a doubtful one; it seems to diminish the irritability of the sensory nerves.

The one symptom against which we are to use opium, then, is the increased peristalsis which accompanies almost every intestinal disorder and continues after the cause has been removed. It is possible by large doses of opium to stop peristalsis almost entirely; the effect of this in fermentative diarrhoeas is to be compared to that of stopping the discharge from a large suppurating cavity while active decomposition is going on.

As a general rule, it may be laid down that opium is contra-indicated until the intestinal tract has been thoroughly emptied by cathartics or by irrigation. If the number of discharges is small, or if these are very offensive, it is not indicated. It is especially to be avoided when marked cerebral symptoms and high temperature coexist with scanty discharges. It is indicated early in the disease as soon as the canal has been thoroughly emptied of putrefying contents; also in certain cases, which are quite common, where the administration of food is immediately followed by a

movement of the bowels; also where, without an elevation of temperature, and often with a good appetite, undigested food, especially fat, constantly appears in the stools, which are frequent, because the intestinal contents are hurried along so rapidly that there is not sufficient time for complete digestion and absorption.

Nothing requires a nicer discrimination than the use of opium in diarrhœa. In all cases I make it a rule to give it in a separate prescription and never in composite diarrhœal mixtures. In this way it can be increased, diminished, or stopped altogether according to the effect desired, while the other remedies used may be continued without interruption.

As to preparations, there is no great choice: paregoric, the deodorized tincture, and Dover's powder have been my preferences.

As to dosage, great variations are required in different cases; enough is to be given to produce a certain effect,—the diminution of pain and control of the excessive peristalsis,—but opium should never be used to the degree of locking up the bowels entirely, or of causing marked drowsiness or stupor. For an average child of one year, eight minims of paregoric, one-fifth of a minim of the deodorized tincture, or one-fifth of a grain of Dover's powder may be used as an initial dose, to be repeated every one, two, or four hours, the frequency being gauged according to the effect produced. Better results are generally obtained by the frequent use of smaller doses than from large ones at longer intervals.

If following the use of opium and a consequent diminution in the number of discharges there is no improvement in their character, and a rise of temperature occurs, too much has been given, and the amount must be greatly reduced or the drug stopped altogether.

Other drugs which have a certain amount of reputation in various quarters are arsenic and ipecac. From neither of these means have I been able to obtain any beneficial effects in acute cases.

*Digestive Ferments.*—Pepsin and pancreatin (*extractum pancreatis*) are valuable additions to our therapeutics. Predigested foods have already been spoken of under dietetics. These ferments may also be given in powder or scale form, the pepsin immediately after feeding, and pancreatin one hour after, with decided advantage. The preparations which I have found most satisfactory, because most active, are those of Fairchild Brothers and Parke, Davis & Co. A large number of those sold in the shops are absolutely inert. In the cases with gradual onset these ferments are of very great value. They are also useful during convalescence.

*Stimulants* are given with advantage in a very considerable proportion of the cases. The amount of prostration is often great and develops rapidly. It frequently happens that practically no food is assimilated for twenty-four or even forty-eight hours, while the drain of the diarrhœa continues. The general condition of the patient is the best guide to the time for stimulation and the amount to be given. Stimulants should be given more frequently and earlier than they usually are. Brandy is the best preparation

for general use, champagne being perhaps preferred when there is very much vomiting. An infant a year old will take an ounce of brandy in twenty-four hours with advantage: sometimes double the quantity will be required.

General considerations in treatment:

1. All cases must be watched carefully and seen frequently.
2. The character of the discharges is in most cases a better indication than is their number of the condition of the patient and of the effect of remedies. Nothing is simpler than to give opium enough to reduce the number of passages, but unless there is some other sign of improvement one has probably done little good and may have done much harm.
3. We must treat the *patient*, and not direct all our thought to acid or alkaline stools, ptomaines or bacteria. Every therapeutic measure must contribute to one end,—viz., the improvement in the patient's general condition. The value of everything is to be estimated by its effect upon this.
4. No matter how strongly we may be convinced of the value of any drug or combination of drugs, if these continue to disturb the stomach they are worse than useless.
5. The use of all drugs is of very minor importance as compared with dietetic and hygienic treatment.
6. In the matter of antiseptics we shall be working in the dark until the life-history of the important intestinal bacteria is understood.
7. Great care is necessary in every case for two or three weeks after an attack, from the strong tendency of the disease to recur.
8. In the management of any single case, the important points are thorough evacuation of the stomach and bowels, then rest to these organs for from twelve to twenty-four hours. No cases do worse than those whose mothers cannot appreciate the value of starvation and who insist upon giving milk in violation of the rules laid down.

## II. CHOLERA INFANTUM.

In comparison with the frequency of the foregoing class of cases those of cholera infantum are rare. They include in my experience not more than two or three per cent. of the cases of summer diarrhœa.

The term should be restricted to cases of genuine choleric form diarrhœa. Much confusion has arisen from adopting this term as a generic one for all cases of summer diarrhœa.

**Etiology.**—This variety is almost never met with in children who are entirely breast-fed. It is never seen except in warm weather. It occurs in very young infants not infrequently, but most of my own cases have been in those from six to fourteen months: age probably has no special influence except in relation to feeding. It is most frequently engrafted upon a mild dyspeptic diarrhœa.

The exciting cause is to be found in almost every case in the food which has been given.

**Symptoms.**—It occasionally happens that cholera infantum occurs suddenly in an infant previously healthy, but this is the rare exception. It is the rule that there is antecedent intestinal disorder: this may be in the nature of a mild dyspeptic diarrhœa of two or three days' or even weeks' duration, or the disease may supervene in the course of a subacute enterocolitis with such severity as to carry off the patient in a few hours.

The development of the choleric symptoms in all cases is rapid, so that in the course of five or six hours a child who perhaps has been regarded as scarcely ill is apparently brought to death's door.

There may or may not be antecedent symptoms of a general character—prostration and a steadily rising temperature—for some hours before the vomiting and purging begin, or these may be the first things to excite attention and alarm. The vomiting may precede the diarrhœa, or both may begin about the same time. The vomiting is often incessant. First whatever food there is in the stomach is rejected, then serum and mucus, and finally bilious matters. If it subsides for a time it is almost sure to be excited anew by the taking of food or drink. The peculiarity of the stools is that they are frequent, large, and very watery. It often happens that in the course of half a day twelve or fifteen passages occur. When less frequent they are proportionally larger. They are of a pale-green, yellow, or brownish color in the earlier part, but as the stools become more and more frequent they often lose all color, and they are almost entirely serous. The sphincter is sometimes so relaxed that the evacuations occur every few minutes in smaller amounts.

The first stools are usually acid, later they are neutral, and the pure serous stools are usually alkaline.

In the majority of cases the stools are odorless; only in rare instances are the exceedingly offensive stools seen; at times the odor is overpowering. Microscopically the stools show large numbers of epithelial cells, some round cells, and immense numbers of bacteria.

Loss of weight is more rapid than in any other pathological condition in childhood. Baginsky records one case which lost three pounds in two days.

The fontanel is depressed, and in rare instances an overlapping of the bones of the skull may occur.

The general prostration is great almost from the outset. The children lose strength very rapidly. The face indicates better, perhaps, than any single symptom what a profound impression has been made upon the system. The eyes are sunken, the features drawn, the mouth depressed at its angles, and a peculiar pallor is spread over the whole countenance, with an expression of anxiety. In the early stages the nervous symptoms are those of irritation; children cry loudly or moan, throw themselves about in their cribs, are peevish, fretful, and quiet for but a few moments at a time. Sometimes they become almost wild in their excitement. Later these symptoms give place to heaviness, stupor, relaxation, and coma or convulsions.

The temperature, in my experience, has been almost invariably elevated, and usually in proportion to the severity of the case. The common elevation in recovering cases has been to  $102^{\circ}$  to  $103^{\circ}$  F., while in fatal cases it has risen almost at once to  $104^{\circ}$  or  $105^{\circ}$  F., and remained at or above that point till death, or it has risen steadily until shortly before death it has reached  $106^{\circ}$  or even  $108^{\circ}$  F. These rectal temperatures often occur with a clammy skin and cold extremities, and are discovered only by the thermometer. Nothing seems to modify essentially this high temperature. Many writers speak of subnormal temperature in the later stages, but such has not been my experience.

The pulse is always accelerated,—150 to 200 a minute. Very soon it becomes weak, often irregular, and finally almost imperceptible.

The respiration is irregular and frequent, and may be stertorous.

The tongue is generally slightly coated, but soon becomes dry and red, and is often protruded.

The abdomen is soft, elastic, rather retracted, and very compressible.

There is almost inextinguishable thirst. Everything in the shape of fluids, especially ice-water, is drunk with avidity, even although vomited almost as soon as it is swallowed.

There is very little urine passed, there may be none at all for twenty-four to thirty-six hours; yet this need give no great concern, with such frequent discharges from the bowels as exist.

Symptoms such as those described rarely continue two days without a decided change either for better or worse; in most cases it occurs in twenty-four hours. In the fatal cases there are the hyperpyrexia, the cold, clammy skin, the absence of radial pulse, stupor, coma and convulsions, and death. The diarrhoea and vomiting may continue until death, but more commonly the vomiting, and very frequently the diarrhoea also, cease altogether for some hours before death occurs.

In some cases the patients pass into a condition resembling the algid stage of epidemic cholera, with pinched, sunken features, subnormal temperature, dyspnoea, and cool breath, and death occurs in collapse.

In other cases, after the first stage of very severe symptoms has subsided, the discharges may diminish somewhat and the nervous symptoms become specially prominent. There are restlessness and irritability or apathy and stupor. The fontanel is sunken; the eyes are half open and covered with a mucous film; respiration is irregular and superficial, sometimes even Cheyne-Stokes; pulse feeble, irregular, or intermittent; extremities cool; muscles of neck drawn back; abdomen retracted; no desire for food, rousing only from thirst. The temperature in these cases is not elevated, but normal or below. From this condition recovery may take place, with gradual abatement in the nervous symptoms, improved pulse and peripheral circulation, and desire for food, the stools gradually becoming more consistent and having more color; or the symptoms may pass into those of enterocolitis, which may last indefinitely. Much more frequent than either of



the foregoing is the fatal termination, either in convulsions or in coma from exhaustion or with a recurrence of the severe vomiting and purging.

These symptoms of diarrhœa have been grouped by the earlier writers, first by Marshall Hall, under the head of spurious hydrocephalus, or hydrencephaloid. They have been variously explained by different writers as due to cerebral anæmia, cerebral hyperæmia (venous), œdema of the meninges, thrombosis of the cerebral sinuses, and uræmia. Regarding the cerebral changes, I can only say that in but a single instance have I met with any which bore any proper relation to the symptoms.\* Although I have examined the brain in almost all my autopsies in diarrhœal diseases, I have never seen in such cases thrombosis, and but rarely œdema. Cerebral hyperæmia was often met with in cases dying in convulsions, but not with any regularity otherwise. Nor have my observations upon the kidneys confirmed the observations of Kjellberg, whom most of the writers since his day have quoted, as to the great frequency of nephritis. Small quantities of albumen in the urine are not uncommon in these cases, but casts and renal epithelium are very rare, and blood I have never seen. The kidneys at autopsy are found generally paler than normal, with a moderate cloudy swelling of the cortex, but not more than is seen in many other febrile disorders of infancy, as, for example, pneumonia.

These facts forbid our regarding either the renal or the cerebral changes as an explanation of the nervous symptoms under consideration. It seems much more in accordance with our present ideas of pathology to consider them as chiefly toxic in character, due to the absorption of poisons developed in the intestines by bacteria there present.

In cases going on to recovery, severe symptoms rarely last more than twenty-four hours before signs of improvement are visible. The vomiting usually ceases first; the stools become less frequent, contain more solid matter, and have more color. There is coincident improvement in the pulse, the temperature falls, and nervous symptoms subside. This last is always to be looked on as a most favorable symptom. Sleep comes, and the great restlessness and irritation pass off. The discharges now partake more of the character of a catarrhal diarrhœa, which lasts a week or more. The great drain upon the system is slowly supplied by nutrition. Convalescence is never very rapid. Sometimes, after all signs of improvement have continued for two or three days, the choleraic discharges return with severity, and the case proves fatal.

*Sclerema.*—This is an infrequent sequel of cholera infantum, and has been described by several German writers, best by Widerhofer.<sup>39</sup> It is met with only in the most feeble children and in young infants, and is charac-

---

\* In this infant the cerebral symptoms were so marked and so characteristic that two excellent physicians who watched the case made the diagnosis unhesitatingly of meningitis. The intestinal symptoms were considered of secondary importance. The autopsy revealed follicular ulcers of the ileum, marked parenchymatous nephritis, and an extreme degree of cerebral anæmia.

terized by an induration of the skin and subcutaneous fat, so that these tissues become everywhere hard and board-like. The body is stiff, cold to the touch, and resembles a half-frozen cadaver. The condition is found associated with contractions, subnormal temperature, and other signs of the most complete prostration. These cases are almost invariably fatal. I have never seen sclerema, nor am I aware that it has ever been described in this country, as a sequel of cholera infantum.

**Pathology.**—What has been said already in the general section on bacteria applies with especial emphasis to cholera infantum. There is no form of diarrhoeal disease met with in which the evidence is so strong of its bacterial origin. Its resemblance to Asiatic cholera is very close. The uniformity in its symptoms, the absence of pathological findings of an inflammatory character, and its close connection with the feeding of cow's milk are all well established.

In the absence of proof to be derived only from experimental bacteriology, positive statements are, of course, impossible. Still, we believe that such study will in the future show the dependence of the disease upon one or more forms of bacteria, and that the symptoms depend upon the absorption from the intestine of the ptomaines formed by such bacteria, either in the food before it is swallowed, or within the body.

The effects are grouped under three heads :

1. Toxic symptoms,—high temperature, prostration, and other nervous symptoms.
2. Paralysis of the vaso-motor nerves of the intestine, resulting in the enormous transudation of serum, which makes up the chief bulk of the stools.
3. Rapid wasting and excessive thirst from abstraction of fluids.

**Diagnosis.**—Cholera infantum can scarcely be mistaken for any other form of intestinal disease if its chief symptoms are kept in mind. The constant vomiting, the profuse serous stools, the great thirst, dry tongue, high temperature, and great restlessness, followed by rapidly-developing collapse, sunken fontanel, pinched, anxious face, cool extremities, weak pulse, dyspnoea, cyanosis, stupor, coma, convulsions, and death, all occurring in the course of one or two days, are unmistakable.

The only things with which the disease can be confused are acute gastro-enteritis and acute dyspeptic diarrhoea.

From the first it is distinguished by its shorter course, by the more intense nervous symptoms, and by the stools, which in cholera infantum are very thin, soon almost entirely watery, and colorless ; in inflammatory diarrhoea they are green or greenish yellow, contain mucus, and are not so large nor so frequent.

In acute dyspeptic diarrhoea we have, as in cholera infantum, the sudden development of quite severe symptoms, with vomiting and diarrhoea, but both are less in degree ; the temperature is not often so high, and it usually falls when the canal has been freely emptied ; the stools contain undigested

food, much gas, and are very foul, but we never have the pure serous stools; the prostration and all the nervous symptoms are very much less, and the disease very rarely proves fatal.

**Prognosis.**—The prognosis is worse in a young infant, worse in one who has been badly fed and poorly cared for, worse when all the surroundings are unfavorable, worse when the patient has suffered from antecedent intestinal disease, and worse in midsummer. Yet almost every year I see stout, well-nourished infants of ten or twelve months, who have been tolerably well cared for, die from this disease. There are certain cases in which it is evident, from the first few hours of their sickness, that death will be the issue. In such cases it is simply cruel for the physician to intimate to the parents that the result might have been different if he had been called in time. No matter what treatment is employed, and no matter how early it is begun, the vast majority of the very severe cases terminate fatally.

The prognosis, then, depends, more than on anything else, upon the severity of the attack.

The symptoms indicating a bad prognosis are hyperpyrexia,  $106^{\circ}$  to  $108^{\circ}$  F., profound nervous depression, and uncontrollable vomiting. Favorable symptoms in the course of an attack are cessation of the vomiting, a falling temperature (not subnormal), quiet sleep, and improvement in the pulse and cutaneous circulation. No case, no matter how severe, should ever be despaired of.

**Treatment of Cholera Infantum.**—The confusion in the use of the term cholera infantum is especially unfortunate when we consider the question of treatment: so many different things are included by writers under the term that it is difficult to estimate the results of various methods of treatment.

Restricting the term to the class of cases described above, all who see much of the disease must be in candor compelled to admit that the results of treatment are extremely unsatisfactory, and that the most severe cases pursue their course but little if at all influenced by the treatment employed. This statement is made after personal trial of almost every method of treatment which has been advocated by writers upon the subject.

In the way of prophylaxis much can be done. All the general rules of prevention laid down in the general section on that subject should be enforced here. Special emphasis, however, is to be laid upon the early treatment of the milder intestinal derangements, since it is a rule to which the exceptions are few, that such symptoms precede for some days the occurrence of the choleric diarrhœa.

No cases of dyspeptic diarrhœa are to be neglected in summer on the score of an existing dentition; every case is to be attended to early and treated energetically, with the idea that at any time a sudden development of dangerous symptoms might occur.

The same remarks apply to convalescence after enterocolitis. Vigilance should not be relaxed for a day until the stools are normal, so often does

one see cases which have been progressing, so far as it is possible to judge, steadily towards recovery cut off in a day by the development of cholera infantum. Unremitting care, and attention to all food, especially milk, must be kept up during the entire hot season.

The main indications to be met in cholera infantum are—

1. To arrest the discharges.
2. To strengthen the heart and sustain the system.
3. To reduce the temperature.
4. To allay nervous symptoms.

It is not desirable, were it even possible, to enumerate all the drugs and therapeutic measures which have been recommended.

The best view of treatment will be had if we keep in mind that these are essentially cases of poisoning, that the toxic materials act by causing great depression of the heart and the strength generally, by acting on the nerve-centres, and paralysis of the vaso-motor system of the intestinal vessels through the splanchnic nerves, and that we are not treating intestinal catarrh, nor intestinal inflammation, although intestinal inflammation is one of the results of the process which is likely to follow if the patient survive the first overwhelming shock of the poison. Nothing in my hands has proved so generally useful as the hypodermic use of morphine in combination with atropine. Although it is capable of doing great harm, I believe it is still of more value than any other means of treatment we possess.

The special symptoms indicating opium are very abundant vomiting and purging, nervous excitement, restlessness, delirium or convulsions, and feeble pulse. Opium is contra-indicated where the purging has ceased or is slight, and where there is drowsiness, stupor, or relaxation. The effects should always be carefully watched, and a small dose repeated is better than a single large dose. For a child a year old not more than one-hundredth of a grain of morphine and one-eight-hundredth of a grain of atropine should be used as the initial dose. It may be repeated in an hour unless the desired effects are produced. These are arrest of the vomiting and purging, or at least a great diminution of them, improved heart's action, and improvement in the nervous symptoms. Here, as in shock, we find morphine our most reliable heart-stimulant.

The use of opium by the mouth is not to be relied upon, owing to the uncertainty of absorption and the liability to produce vomiting.

Henoeh<sup>40</sup> has reported favorable results from the free use hypodermically of a one-per-cent. saline solution.

In the treatment of the hyperpyrexia all drugs are useless. Even where they are retained, we get little or no effect from antipyrin, antifebrin, and drugs of this class, used in any safe doses. The only means to be relied upon is cool baths. The child should be put in a tub-bath at the temperature of 100° F., to avoid shock and fright, and the temperature of the bath gradually lowered by adding ice to 85° or 88° F. This may be kept up

for from ten to thirty minutes, according to the amount of reduction in temperature effected. Baths to be efficient must be used at very short intervals, as often as every hour if symptoms are threatening. Iced cloths or an ice-cap should be kept applied to the head. Ice-water injections are a valuable accessory to the treatment by baths. A rectal tube should be used, and the injection carried high up into the colon, the water being allowed to flow in and out freely.

The only things to be allowed by the mouth are champagne and brandy and ice. They must be given in minute quantities every few minutes. Sometimes even these cause vomiting; then everything must be withheld and stimulants used hypodermically. Either brandy or ether may be employed; they should be used freely. To attempt to give food by the mouth, astringents, or in fact drugs of any kind, is worse than useless.

After vomiting has stopped and the purging is in a measure controlled, nourishment in very small quantities may be tried: for a young infant breast-milk should be obtained if possible. Cow's milk should not be employed unless completely peptonized. Whey, koumys, or kéfir may also be given, and they will usually be taken eagerly, on account of the thirst: beef or chicken broth may be tried in older children. The amount of food and the frequency of feeding must depend on the case. In the beginning everything should be tried in teaspoonful doses at half-hour intervals; later, if well borne, the amount may be cautiously increased and the intervals made longer. It is always to be remembered that during the most acute symptoms there is absolutely no digestion, and that it is some time after before the organs are able to dispose of much food. If the cases go on to a favorable result, subsequent feeding is to be carried on according to the principles laid down under the head of dyspeptic diarrhœa. After the stage of violent diarrhœa and vomiting has passed, if the symptoms described as hydrencephaloid are presented, the case is to be managed according to its symptoms. Opium is to be avoided; stimulants by the mouth are to be used freely where they can be retained, and, where not, hypodermically. If there are cold extremities and subnormal temperatures, hot mustard baths should be used to establish reaction, sinapisms applied freely all over the body, and hot-water bags or bottles used all about the patient. Baginsky recommends hot-water rectal injections. Camphor is sometimes useful as a stimulant.

Hygienic treatment during convalescence is all-important. If the patient survives the first violent stage, he should be removed as soon as possible: if in the city, to the sea-shore; if at the sea-side, to the mountains: a change of air is the important thing.

A continuance of the fever and diarrhœa without the extreme nervous symptoms and after the vomiting has subsided, means usually that the case has become one of entero-colitis: it is then to be managed like such cases beginning without the choleraic symptoms.

## VIII. ACUTE ENTERO-COLITIS.

**Synonymes.**—Enteritis, Enteritis follicularis, Dysentery, Colitis, Ileo-colitis, Inflammatory diarrhœa.

The term ileo-colitis is perhaps preferable to the term entero-colitis, as being more exactly descriptive of this disease, or rather these diseases; but, as entero-colitis has become pretty generally accepted in literature, it is not advisable to displace it. The term follicular dysentery or follicular enteritis is open to very serious objection, for the reason that although inflammation of the lymph-nodules (solitary follicles) is the most common lesion, cases are seen, as yet indistinguishable from them clinically, in which the lesion is of quite a different character, these being either croupous or severe catarrhal.

The term acute entero-colitis is used here as a clinical one to embrace all the forms of acute diarrhœal disease with demonstrable inflammatory lesions.

For a description of these lesions the reader is referred to the general section on pathological anatomy. It need be remembered here only that the colon and the lower third of the ileum are the parts most affected, and usually the only parts affected.

**Etiology.**—Reference is again made to the general section on etiology. The factors of especial importance here are vitiated constitution and bad habits of feeding, especially in older children. Entero-colitis may occur at any time of year, although, of course, very much more common in the warm season.

Cold has long been regarded as a prominent factor, but with our present light upon this subject we cannot help thinking this view open to question.

This form of diarrhœa is occasionally seen as a complication of measles and scarlatina, but more commonly of diphtheria.

**Symptoms.**—Clinically three quite distinct forms are met with: first, the dysenteric form, which is primary; secondly, the more common acute variety, which usually begins as an acute dyspeptic diarrhœa or follows cholera infantum; thirdly, a subacute variety, which may follow either of the foregoing.

**THE DYSENTERIC FORM.**—These cases constitute but a small proportion of the class. They are more common in older infants than during the first eight months. The onset is sometimes quite abrupt, and sometimes gradual. In the abrupt cases we have often severe constitutional symptoms, the temperature rising to 104° or 105° F., prostration, not often vomiting, but severe nervous disturbance, frequently delirium, rarely convulsions. In the cases with gradual onset, which are much more common, the temperature is scarcely elevated at all, and the symptoms are almost entirely those of an intestinal character. After one or two fecal stools, the discharges consist of almost pure mucus, or mucus streaked with blood,

more rarely blood in clots. There is usually but little odor to these stools, but sometimes it is very marked. They are frequent, often every half-hour, and proportionally small, sometimes only a teaspoonful being found on the napkin after severe straining efforts. There are almost constant tenesmus and griping in severe cases. Prolapsus ani is a frequent complication, and sometimes a very troublesome one. As the case goes on, the passages contain more or less undigested food, and usually lose their peculiar character or have it only occasionally.

In severe cases there may be very great prostration, rapid wasting, and death, from exhaustion or from complications, in a week. More often they assume after a time the symptoms of an ordinary entero-colitis, and run a slow, indefinite course, with a tendency to frequent relapses.

These cases are described by many writers as cases of dysentery, a term of very uncertain significance, and, hence, objectionable. Used as it is by some to include all the varieties of inflammation of the colon, it is certainly a misnomer and has led to much confusion. As has been already stated in the introductory section, in the inflammatory diarrhœas of infancy and childhood it is the rule, to which exceptions are few, that the lesion is chiefly in the colon. Moreover, extensive lesions frequently exist without the symptoms commonly known as dysenteric. Dysenteric symptoms, such as have been described above, seem to depend upon the fact that the lesion is situated in these cases chiefly in the rectum and sometimes possibly in the sigmoid flexure.

There is no objection to the term when it is used to characterize certain symptoms only, and not to describe a pathological condition. We cannot now do better than to regard these cases simply as cases of colitis.

**THE ACUTE FORM.**—Much more common than the foregoing are the cases of entero-colitis which follow an acute dyspeptic diarrhœa or cholera infantum. When the latter, we have a cessation of the vomiting and the serous discharges, with a fall in the temperature, and many of the profound nervous symptoms pass off. The stools become more consistent, of a brown, gray, or greenish color, contain large quantities of mucus and undigested food, and are more or less offensive. Some appetite returns. The symptoms of shock which characterize the cholera-infantum stage pass away, and the pulse improves; but there are continued loss of flesh, some fever, usually  $101^{\circ}$  to  $102^{\circ}$  F., restlessness, peevishness, etc. These symptoms may last for two or three weeks, with exacerbations and remissions.

The exact relation of acute dyspeptic diarrhœa to entero-colitis is not quite clear. Clinically we meet with many cases characterized by the abrupt development of severe gastro-intestinal symptoms, vomiting, high temperature, diarrhœa, and nervous symptoms, which are convalescent in two or three days.

We see others in which there is improvement in all the severe general symptoms: the temperature falls nearly to normal, the vomiting ceases, and there is improvement in the nervous symptoms, but those belonging to the

intestinal tract continue,—the stools being less numerous, less watery, less offensive usually, with less flatulence, but more mucus, and occasionally streaked with blood. Again we see cases in which there are two or three such initial attacks before the continuous diarrhoea is finally established, these being separated by a number of days, or even weeks, in which, as a rule, however, the stools never become quite normal.

There is another class of cases, not nearly so numerous as those just mentioned, in which the initial symptoms are indistinguishable from those described, but the severe inflammatory symptoms continue without any remission for from four to ten days, until death takes place, or, more rarely, they gradually subside after a variable time and the cases end finally in recovery.

It seems likely, then, that the majority of the cases of entero-colitis are preceded by an acute dyspeptic diarrhoea; that in some this is not set up until the second or third attack; and that in a smaller number a continuance of the severe initial symptoms makes it likely that there existed from the beginning an intense intestinal inflammation. In the last variety the autopsies confirm this opinion. Whatever the mode of beginning, when well developed the cases of entero-colitis present symptoms which are fairly constant and characteristic.

*Temperature.*—It may be stated as a rule to which there are few if any exceptions, that acute inflammatory lesions of the intestine are accompanied by fever, more or less continuous; and, conversely, that when we find a continuous temperature with intestinal symptoms we may safely infer inflammatory changes, the extent of which depends on the intensity and duration of the fever. This is an important point, for it often serves to differentiate entero-colitis from acute dyspeptic attacks. In the latter the temperature may be high, but is of short duration, since it does not depend on inflammation, but is rather toxic. There are no typical temperature-curves in acute entero-colitis. The temperature is usually higher in the beginning and towards the end of the disease. A high temperature towards the close is much more common than a subnormal temperature, although the latter is sometimes seen.

Hyperpyrexia in these cases is not common, but when it occurs it betokens usually an early fatal termination.

A rise in the temperature is often coincident with a great reduction in the number of the discharges, either from the use of opium or otherwise. Such temperatures are to be looked on as toxic, and demand purgatives, not antipyretics, for their treatment. It need hardly be said that complications at any time may cause a rise in temperature. The principal one to watch for is broncho-pneumonia.

*Pulse and Circulation.*—The pulse is always increased in frequency, generally in proportion to the other febrile symptoms. Frequency of pulse is of little or no diagnostic or prognostic significance. It is of great importance that the character of the pulse should be noted. In bad cases it is



feeble, irregular, or intermittent. The capillary circulation is poor, and the extremities are often cold, even when the rectal temperature is elevated.

*Nervous Symptoms.*—These are marked in this as in almost all other intestinal disorders. In the early stage they are the symptoms of irritation, —great restlessness, constant crying from thirst or pain, rolling from side to side in the crib, biting at the fingers, scratching the face, etc. The later symptoms are of quite the opposite character, there being dulness, apathy, and general relaxation, so that these infants may lie sometimes for hours unless they are disturbed. These symptoms arise from a combination of causes,—partly from exhaustion and innutrition, partly from anæmia and loss of fluids, partly from fever, but chiefly, I think, they are toxic.

*Mouth and Tongue.*—During the early stage the tongue is usually coated heavily and moist; later it is often dry, red, and glazed; the lips crack and bleed readily. The buccal mucous membrane may be the seat of almost every variety of stomatitis; thrush is altogether the most common, and is seen most frequently in young infants. The condition of the tongue is of no diagnostic importance as a symptom of intestinal ulceration. Severe stomatitis of any form, and dry tongue and mucous membranes, are always unfavorable symptoms.

*Vomiting* is not a symptom depending upon entero-colitis. When present throughout the disease, which is exceptional, it depends upon coexisting gastritis. The great proportion of the cases have vomiting as an initial symptom, and here it depends rather upon the primary acute dyspeptic attack, in which the whole alimentary tract is more or less deranged.

Persistent vomiting developing in the course of entero-colitis is always a bad sign, and means often the supervention of cholera infantum and speedy dissolution. Single attacks of vomiting depend usually upon dietetic errors.

*Stools.*—The frequency varies greatly, and is usually inversely proportional to the size of the discharges. The small mucous passages streaked with blood may be from fifteen to thirty daily. Of the larger ones from four to ten daily constitute about the average. They are nearly always more frequent during the day than at night, which seems to show that the frequent feeding and handling of infants increase their number.

Diminution in the number of discharges is not always a sign of improvement; if this is accompanied by a rising temperature and increasing nervous symptoms, it is a bad sign. The stools sometimes cease entirely for from twelve to twenty-four hours before death, depending probably upon paralysis of the muscular coat of the bowel.

The reaction of these stools is usually acid, occasionally neutral, but in my experience very rarely alkaline.

The pure mucous stools are generally odorless; those containing much undigested food are frequently very offensive.

In color and consistency they vary almost without limit. They may be gray or grayish brown, bronze, yellowish green, grass-green, or yellow. They may be brown or black from blood, or from drugs, especially bismuth

or iron. They are rarely watery except during exacerbations; they are semi-solid, but not homogeneous.

In composition they are an almost indescribable mixture of food-remains, intestinal secretions, blood, epithelial and pus cells, and bacteria.

The food-remains depend, of course, on the diet. If this is milk principally, white masses of fat are almost constant, with occasional curds. Various cereals—armeal, rice, barley, etc.—can be recognized by the naked eye, and all starchy foods by the iodine test or by the microscope. If only bread, papines, and other predigested foods are given, the stool may consist almost entirely of intestinal secretions, mucus, bile, and epithelial elements.

Mucus is clear and glairy only when it comes from the lower colon. From the upper colon and the small intestine it is stained with bile and mixed with fecal masses and undigested food. It is the most constant feature of these stools.

Blood is most frequently in small quantity, only enough to streak the stool faintly. Blood in clots or fluid blood is not common. It is an early symptom rather than a late one, and depends upon congestion and not on ulceration. In twenty of my own cases in which the autopsy showed intestinal ulceration, blood was entirely absent from the stools in fourteen.

Pus in quantity sufficient to be recognized by the naked eye I have never seen in children. In the severe cases pus-cells are found under the microscope quite uniformly.

Shreds of this membrane, or sloughs from the intestinal wall, I have rarely seen in the stool in infancy. They are not so uncommon in older children.

For the microscopical examination the reader is referred to the general section on diarrhoeal stools. We cannot say that, as yet, this examination has shed much light upon diagnosis or therapeutics. For a discussion of bacteria see Dr. Booker's article in this volume.

*The abdomen*, may be hard and distended during the early stage, while the dyspeptic symptoms are prominent, or at any time during the course of the disease when an acute exacerbation takes place. At other times it is natural, or retracted and soft. Tenderness on pressure along the line of the colon can sometimes be made out in older children. Enlargement of the mesenteric glands sufficient to be made out by palpation I have never seen in entero-colitis.

*The appetite* is in most cases impaired: it may be completely lost, and there may be disgust for almost every article of food. In some cases it is almost impossible to get the children to take anything in the shape of nourishment. Such a state of things greatly increases the difficulty of management and affects the prognosis very unfavorably.

The cases where children take willingly everything given are rare. They may do so from thirst when the temperature is high, but not at other times. It is more common for them to be apathetic and never ask for food or even for drink. A returning appetite and a relish for food are always very favorable signs.

*The urine* is nearly always diminished in quantity and high-colored, and frequently is loaded with urates. It is not uncommon to find a small amount of albumen, particularly when the temperature is high. But albumen in large amount, renal epithelium, and casts are exceedingly rare. I have met at autopsy with but a single case in which there was nephritis marked enough to have seriously diminished the patient's chances of recovery or to have formed an important factor in the fatal result.

*Nutrition and Weight.*—Failure of nutrition and loss of weight are more rapid in diarrhoeal diseases than in any other disease of infancy. They depend on failure in digestion and absorption, and on the continued drain caused by the stools. An important factor is the increased peristalsis, which hurries the food along the intestines before absorption can take place. The loss of weight is not so rapid in enterocolitis as in cholera infantum, but it is steady and progressive, and is one of the best guides to the patient's nutrition. It is particularly important in the subacute cases and in convalescence to take the child's weight accurately and often,—at least twice a week,—as a guide to dietetic and medicinal treatment.

As emaciation goes on, the skin hangs loosely on the thighs and abdomen and can be pinched up in large folds. At the same time it becomes doughy, dry, and sometimes scaly.

Though rapidly lost, the flesh is slowly regained, and it may require many months to recover what is lost in two or three weeks.

*Prolapsus ani* is not a very frequent symptom, but is a very annoying one. It may occur only occasionally, or it may come with every stool. In the milder cases the tumor is the size of a small hen's egg and is flattened. In the severer ones it may be as large as a lemon. Reduction is in most cases easy, but retention is sometimes difficult.

**SUBACUTE CASES.**—After acute symptoms such as have been described have lasted for a variable time,—from two to four weeks,—the fever nearly or quite ceases, the stomach is quiet, food is readily taken, and most of the nervous symptoms have subsided, but the diarrhoea continues, and there is no improvement in nutrition: there is cachexia, with extreme anemia. The stools in these cases are not very frequent,—only four or five daily; they continue to contain large amounts of mucus and undigested food, and are often of a very bad odor. They may improve for a day or two upon a change of diet or medical treatment, but soon return to the old condition. After such symptoms have lasted five or six weeks, there is gradual improvement in the stools and in weight, and the patient enters upon a slow convalescence, which is likely to be often interrupted by relapses, or the symptoms continue, and the case becomes one of chronic diarrhoea.

The different pathological varieties—catarrhal, croupous, and follicular—so much resemble one another clinically that it seems scarcely worth while to give each one a separate section. There are, however, points of difference which are fairly constant, and should be borne in mind.

*The croupous variety*, relatively rare, is the most intense of the three, and

is characterized by the highest temperature and the severest constitutional symptoms. The temperature runs from 102° to 105° F.; blood in the stools is a frequent feature, and it sometimes comes in large amounts. The cases are frequently among those who were previously in good condition, sometimes in delicate subjects or those prone to diarrhoeal attacks. The progress is steady and rapid, the symptoms lasting, in fatal cases, about a week. Cerebral symptoms are common, especially restlessness, irritation, and delirium. The appearance of shreds of membrane in the stools is about the only symptom which can be said to be positively diagnostic. But this is not often to be expected in infancy: the stools should be washed with water in looking for it.

Diagnosis being in a measure uncertain, it is impossible to say exactly what proportion of these cases recover, but it is certainly very small.

*Acute Catarrhal Variety.*—The very severe cases of this class resemble in all respects those of croupous inflammation. There are the rapid course, the intense symptoms, continuous high temperature, prostration, etc. The shortest case I have seen lasted three days. These cases are almost certainly fatal.

In the milder variety, much more common, the temperature is lower,—101° to 103° F.; the stomach is more apt to be involved, and the stools are more thin and watery. They are often streaked with blood in the early stage.

The great proportion of these cases recover. The acute inflammatory symptoms subsiding after a week or ten days, they are succeeded by mild intestinal derangement for from two to three weeks more; but the patients are often two months in regaining their previous condition of strength and weight. Relapses are common.

*Follicular Ulceration.*—The cases in which the lymph-nodules are principally involved are characterized generally by lower temperature, by less disturbance of the stomach, and by their slower and more irregular course. There is usually progressive emaciation. They last from ten days to eight weeks.

Desirable as it is, both for prognosis and for treatment, to know whether or not the lymph-nodules have broken down and formed ulcers in the intestine, it must be admitted that the diagnosis is still a matter of a good deal of uncertainty. The following is a *résumé* of twenty cases in which autopsy showed follicular ulcers.

<i>Duration of disease:</i>	Seven days or under (one five days) . . . . .	2
	From twelve days to three weeks . . . . .	12
	Four weeks and over . . . . .	6
<i>Previous condition:</i>	Poor (one syphilitic) . . . . .	11
	Good . . . . .	6
	Doubtful . . . . .	3
<i>Temperature:</i>	High (102°–104° F.) . . . . .	3
	Medium (100°–102° F.) . . . . .	10
	Almost no rise . . . . .	7
<i>Blood in stools:</i>	Abundant . . . . .	2
	Traces . . . . .	4
	None . . . . .	14

<i>Age</i> : Under six months . . . . .	1
From six to ten months . . . . .	7
From ten to twenty-one months . . . . .	12

It will be remembered in this connection that cases of tubercular ulceration are not included. It has been stated by Baginsky that the constant presence of pus-cells in great numbers in the stools may be regarded as pretty positive evidence of ulceration. My own experience in the microscopical examination of these stools has not been large, but so far it leads me to the view that, while the finding of pus as described is of considerable diagnostic importance, we are not to regard the negative symptom as having any special weight.

The diagnosis of follicular ulcers is rather to be made from the case taken as a whole. If a delicate infant which from time to time has been specially prone to diarrhœal attacks, especially if it has had symptoms of a mild catarrh of the colon, has an attack which starts in with green mucous stools and which continues with unabated severity for a week or ten days with low fever, we think of acute follicular inflammation as certain and of ulceration as probable. If these symptoms continue for three weeks without intermission, the child all the time failing steadily in strength, the probability becomes almost a certainty.

If, on the contrary, after three or four days of acute symptoms there is improvement in the stools, and one occasionally quite fecal in character, and if after a few days another such exacerbation occurs, succeeded by another remission, and so on, we may be tolerably sure that no ulcers have yet formed.

If follicular ulcers have formed, the chances of recovery are small. The fact that these occur at all indicates usually a pretty active inflammatory process and little resistance on the part of the tissues.

The majority of the cases of "follicular" inflammation undoubtedly recover. In these cases there is probably only swelling of the lymph-nodes without ulceration, coupled with more or less catarrhal inflammation, the two being usually associated.

**Termination.**—Enterocolitis may terminate—

1. In complete recovery. Even in these cases there is usually a protracted convalescence of from three weeks to three months.
2. In recovery so far as the intestinal disease is concerned, but with such impairment of the constitution that the children fall an easy prey to pneumonia in the succeeding winter, or to any infectious disease which may be prevalent.
3. In death from exhaustion, with progressive failure in strength, and wasting. These cases last from three to six weeks, and include nearly one-half of the fatal cases.
4. In death after from four to ten days, with a continuance of severe inflammatory symptoms from the beginning.
5. In death from an exacerbation of acute symptoms in cases going on

apparently to a slow recovery. Such relapses and exacerbations are very easily excited.

6. In death from intercurrent cholera infantum.

7. In death from complications,—chiefly broncho-pneumonia and tuberculosis.

**Complications**—*Skin*.—During the early acute stage an intense erythema frequently develops about the anus, nates, and genitals; in severe cases the thighs, loins, and legs are also involved. It is the result of irritation partly from the stools and partly from the frequent washing. The process may be superficial and result in a loss of epidermis only, or the corium may be involved and superficial ulcers form, and even sloughing may occur in bad cases.

An extensive erythema is a great annoyance and adds to the gravity of the case. Sloughing is rarely seen, and then only in patients who would almost certainly die from other causes.

Furuncles are very frequently seen during convalescence, and are particularly likely to appear upon the face and scalp.

*Mouth*.—Stomatitis is a very frequent complication of entero-colitis. The most common is the simple catarrhal form, which occurs both with and without dentition. In severe cases, especially when protracted, thrush is likely to develop. Occasionally, also, we meet with the small round follicular or aphthous ulcers. As a rule, the more the stomach is involved the more common are these buccal complications.

*Glands*.—Occasionally enlargement of the glands of the inguinal region is met with in the subacute cases, but this is rarely pronounced. I have never seen any degree of swelling of the mesenteric glands (unless tubercular) sufficient to be made out by abdominal palpation.

The other complications—broncho-pneumonia, tuberculosis, pleurisy, peritonitis, and nephritis—have been already discussed in the section on pathological anatomy.

**Diagnosis**.—The differential diagnosis of entero-colitis from cholera infantum and acute dyspeptic diarrhoea has already been discussed under these diseases. Entero-colitis is further to be distinguished from typhoid fever, tuberculosis, and intussusception. A doubt between typhoid fever and entero-colitis in infancy can scarcely exist. Notwithstanding the fact that from time to time cases of typhoid in infancy are reported, those under twenty months in which the diagnosis was confirmed by autopsy are extremely few. At this age it can be practically ignored.

In older children the difficulty is often a very real one. Typhoid is usually distinguished by its more constant fever, the enlargement of the spleen, the tympanitic distention of the abdomen, and most of all by the eruption. The fact of an epidemic prevailing is also to be considered.

The dysenteric form of colitis may be confounded with intussusception. If the possibility of this mistake is kept in mind it will not often be made. Yet the records of the cases of intussusception show that in the beginning

a very large proportion of them had been regarded as cases of dysentery. In intussusception we have a very sudden onset (often the hour can be definitely stated by the mother); there are acute pain and tenesmus, followed by bloody and mucous passages. The amount of blood often is quite large,—as much as a tablespoonful of clear blood. There is vomiting, often persistent, with very marked prostration, but no fever. It is only at the outset that the mistake is likely to occur. The later symptoms—absolute stoppage of the bowels, an abdominal tumor, tympanites, rising temperature, collapse, and stercoraceous vomiting—have nothing in common with dysenteric colitis. In the latter there is rarely so abrupt a beginning or early vomiting; there is usually fever; the quantity of blood is generally smaller and the prostration is less.

The differential diagnosis from tuberculosis is considered under the head of chronic diarrhoea.

**Prognosis.**—In making a prognosis in a given case one must consider the child's constitution, its surroundings, the ability of the parent to carry out a proper line of treatment, the duration of symptoms at the time the case comes under treatment, the part of the summer in which the attack occurs, the existence of complications, and certain particular symptoms.

The prognosis is worse in a feeble or cachectic child, in one suffering from rickets or with inherited tubercular tendencies. It is worse in cities, among the poorer classes, and in institutions. The chances of recovery are much reduced if it is impossible for fresh air or change of air to be secured, and under all circumstances where the matter of diet especially cannot be looked after by an experienced nurse. The longer the symptoms have lasted, particularly febrile symptoms, the greater is the probability of severe anatomical changes and the worse the prognosis. Cases occurring in June or early in July have a worse prognosis than those occurring in the latter part of August or in September, for the reason that the earlier cases have still the greater part of the summer to get through and are likely to suffer from relapses during the rest of the warm season.

The prognosis is rendered less favorable by the existence of any complications, such as severe stomatitis, eczema, nephritis, and especially broncho-pneumonia and tuberculosis.

It is worse in children who have been previously badly fed, in those who have been recently weaned, and especially in those who have suffered earlier in the season from diarrhoeal attacks. The particular symptoms which make the prognosis bad are a continued elevation of the temperature, frequent vomiting, rapid wasting, and continuous severe nervous symptoms.

It is never safe to give an absolutely good prognosis until the end of the hot season, on account of the great liability of these cases to relapses and recurrent attacks.

**Treatment.**—Prophylaxis involves all that has been said in the general section, with especial emphasis laid upon the necessity of early and prompt treatment of all the milder forms of diarrhoea, before the process shall have

gone on to the formation of serious anatomical changes. Especial care should be taken to prevent over-exertion in children of two or three years in very hot weather.

*Hygienic Treatment.*—Almost all that has been said upon this point under Dyspeptic Diarrhoea is applicable here. Change of air from the city is imperative. If children are to be kept long away, inland is generally preferable to the sea-shore. The district should be high and dry and one in which the local surroundings are good. Even after they have recovered it is not safe to allow children to return to the city until the last of September, since a return during the warm season would be very likely to cause a second attack. If there has not been complete recovery, relapses follow almost inevitably.

Fresh air, pure air, and plenty of it, is a necessity for all cases. The same directions for bathing should be followed as are given under Acute Dyspeptic Diarrhoea.

It is still a debatable point whether children sent from the cities to suburban or sea-side hospitals do better in tents or in wooden buildings. My own experience is against the use of tents, as being hotter during the day, and so much cooler at night, especially during August and at the sea-shore, that there is greater danger of pulmonary complications. Great care must always be taken to see that children are warmly covered at night. This is often overlooked, as the days are so hot.

*Dietetic Treatment.*—In the early stage, if the stomach is affected the case is to be managed as one of acute dyspeptic diarrhoea. The gastric symptoms will usually have subsided at the end of two days, and we have then only the intestinal ones to deal with.

If an infant is nursing, and the breast-milk is above suspicion, there is no reason for its withdrawal.

If the infant is but a few months old, and hand-fed from the beginning, or just weaned, its life may depend upon securing a wet-nurse. Whenever this is possible it should be done, if only for a few weeks. If it is out of the question, we begin with barley-, rice-, or arrowroot-water, or thin mutton or chicken broth, and come back gradually to cow's milk. Milk may be tried as in dyspeptic diarrhoea, first completely peptonized (two hours), then diluted with four or five times its bulk of gruel made from "flour ball," barley flour, or rice (see page 116). If curds or fat-masses appear at once in the stools on the addition of the milk, it must be stopped and the white-of-egg mixture substituted. Or some of the prepared foods—Liebig's, Horlick's, or Mellin's—may be tried, made without milk. Condensed milk will sometimes agree when milk in other forms fails, but much oftener it will not.

The greatest care should be taken to see that the milk is the best that can be obtained, and that it is sterilized, or at least boiled, and kept on ice, never in the room nor out of the window. Milk which turns the blue litmus paper quickly should not be used; but this test is not enough, as



much milk may be unfit for use from other conditions not revealed by litmus paper. Other useful articles are the meat extracts, which are generally inferior to freshly-prepared beef juice.

Raw scraped or pounded beef which has been put through a sieve and rolled into little balls with salt or sugar is sometimes a valuable resource. The danger of tape-worm has, I think, been greatly exaggerated. Two or three teaspoonfuls of this meat can be given daily.

These cases are apt to be protracted, and children soon tire of every food given; of milk least, so that whenever it can be borne we rely on it as our main-stay: if it appears in the stools undigested we must give it in greater dilution or stop it altogether.

The dangers of overfeeding and too frequent feeding are great. But the opposite one, of too little nourishment, should be avoided. These infants are often so dull and apathetic that they scarcely make a sign for food if it is withheld almost altogether. An exact record should always be kept of just how much the child does take, and the physician may find that a child of six months, who ought to get in bulk from twenty-four to thirty ounces in twenty-four hours, gets only eight or ten. Children should be fed regularly, not oftener than every two hours.

It is always important that foods giving as little residue as possible be chosen, so as to leave as little as possible to cause irritation and decomposition in the lower intestine.

In older children, the milk diet, or diet of milk and gruel of wheat or barley flour, alternating with mutton broth, usually succeeds best.

Especial care should be given to the diet during convalescence. Relapses come on very readily from all causes, but from nothing else so readily as from improper feeding. Especially to be avoided in younger children are oatmeal, potatoes, tomatoes, and, in fact, all vegetables and also all fruits. I have seen a single peach excite a dangerous relapse, and a few raisins a fatal one. The general rules laid down in the feeding of cases of dyspeptic diarrhœa might be repeated here with emphasis.

*Medicinal Treatment.*—In the early stages the case is to be managed as one of acute dyspeptic diarrhœa, by evacuants, antiseptics, and the judicious use of opium.

If, however, acute febrile symptoms have continued beyond the third day, we may be pretty sure that we have lesions of some consequence to deal with. It is to these, rather than to the putrefactive processes, that the subsequent treatment must in the main be directed.

It is of the first importance now that nothing should be done to disturb the stomach or the powers of digestion, which are always impaired to a greater or less degree. Hence we should be very cautious about overdosing our patients or giving any nauseating mixtures.

From time to time, according to indications, we may seek to aid stomach-digestion by the use of pepsin, hydrochloric acid, pancreatin, and alkalies, either lime-water or magnesia, added to the food. The progress of the

lesions below depends very much upon how well we can nurse the feeble powers of digestion and absorption.

We do not hope by any of the above measures to influence the condition in the intestines directly, but indirectly.

Antiseptics are now of much less value than in the cases of acute dyspeptic diarrhœa. Calomel does but little good except in the acute exacerbations which come on from time to time, and resorcin seems in some cases to do harm. The salts of salicylic acid, both the sodium and calcium salts, and salol, given as previously directed, seem to do more good than anything else except bismuth. Whether the action of bismuth in these cases is astringent or antiseptic, or whether it acts mechanically by coating the inflamed surfaces, we do not know; probably it partakes of all three qualities. Bismuth frequently fails because the doses given are entirely inadequate. Doses of five grains of the subnitrate four or five times a day are almost worthless. At least two drachms a day should be given to a child a year old, and the amount increased proportionally for older children. If a good preparation is given, there need be no fears of unpleasant symptoms. I have never seen any from that manufactured by Squibb.

Talcum (silicate of magnesium) was long ago used by Trousseau with success, and its use has been recently revived by Debove and Sevestre.<sup>41</sup> It is a bland, inert powder, and is given in suspension in the doses in which we prescribe bismuth.

The commonly employed vegetable astringents, kino, catechu, krameria, etc., as well as the mineral astringents, acetate of lead and nitrate of silver, have been in my hands absolutely worthless, and the sooner they are dropped from our therapeutics in this class of diseases the better, I think, will be our results. Their only action is local, and, introduced in any sufficient dose to produce local effects, they almost inevitably disturb the stomach. Their local effect can be much better obtained by their use in enemata, under which head they will be referred to.

Opium is valuable in these cases, but must be used with great discretion. It is particularly indicated when the stools are thin, frequent, of a not very offensive character, and when they are excited by the ingestion of food. It is to be used with great caution when the stools are small, infrequent, and very foul, and also when there are marked nervous symptoms. It is always best given in a separate prescription and used occasionally for a specific effect. For doses and preparations reference is made to the remarks on the use of opium in acute dyspeptic diarrhœa. In the cases with dysenteric stools I have seen great benefit in many instances from the use of the old-fashioned emulsion of castor oil. A good formula is the following:

R Olei ricini,  
Spts. vini Gall., āā ℥viii;  
Mucil. acaciæ,  
Aq. dest., āā ℥ss.  
Misce.

Sig.—One dose for a child of twelve to eighteen months; repeat every two to four hours.

Opium is generally needed in these cases, but it is better to give it separately.

In these cases, and in some others where there is much colicky pain and tenderness of the abdomen, with stools streaked with blood, much benefit may be derived from a thin flaxseed poultice applied to the abdomen, or from mild counter-irritation by turpentine stupes or by mustard.

Stimulants are needed in almost all cases. There are no valid objections to their use even in young infants. If alcohol is ever justifiable in medicine, it is in these cases of intestinal inflammation, where we have extreme prostration, feeble powers of digestion and assimilation, and often a great repugnance to food of every kind. There is in these cases no more danger of acquiring the alcoholic habit than there is of acquiring the opium habit.

Stimulants are needed in the early stage as soon as the pulse becomes weak and the capillary circulation poor. At this time old brandy is the best preparation for most cases. Blackberry brandy is preferred by many. It should be given well diluted. As much as thirty drops every hour can be given to an infant of a year; in severe cases and for short periods, a much larger amount proportionally. It should be given for an effect, which is mainly an improvement in the pulse and in the patient's strength. In cases of sudden collapse it may with advantage be used hypodermically.

Other heart-stimulants are in these cases much inferior to alcohol.

In the subacute cases drugs do not seem of very much value. They are vastly inferior to hygienic and dietetic measures. Bismuth may be used for a considerable period, and seems to do more good than anything else. Opium is to be given only occasionally, as symptoms may require.

The prevailing tendency in practice is to overdose these cases. Often, after changing the treatment every fifth or sixth day for as many weeks, I have stopped everything except food and stimulants, and more than once have found patients to do better without drugs than with them. In these subacute and chronic cases it is advisable every week or ten days to stop all medication for two or three days, and see how the patient is. Overdosing very frequently does harm by its effect upon the stomach.

*Local treatment* is of very great value in these forms of diarrhœa. It will be seen by reference to the pathological anatomy that the lesion is chiefly in the colon, very often exclusively here, and that it is usually the lower half of the colon which is most seriously involved. Manifestly, then, if we wish to treat the lesions by drugs designed only for local effects, the proper mode of administration is by the rectum and not by the mouth.

Rectal injections are of two kinds: first, irrigation, which contemplates flushing the entire colon as far as the ileo-cæcal valve, large quantities of the fluid being used, it being allowed to flow in and out freely; secondly, the use of enemata or clysters, in which a smaller amount of fluid is injected and retained for some time in the intestine, for its local effect.

The method of irrigating the colon has already been described. (See

Dyspeptic Diarrhoea.) Its purpose is mainly to empty the intestine completely of all masses it may contain. It need not be repeated more than twice daily, and usually once a day is enough. As an injecting fluid a simple saline solution is generally preferred (one drachm of common salt to a pint of water): this is less irritating than plain water. If there is much mucus, a borax solution of the same strength may be employed. The water should flow in and out until it is quite clear, from one to two gallons being used at once. If the fluid has been properly introduced, the outline of the distended colon can usually be seen and felt. For general use a temperature of about 80° F. is preferred. In cases of collapse hot injections (110° to 115° F.) have been advised, and in cases of high temperature and active inflammatory symptoms ice-water may be used with advantage.

The use of antiseptic solutions—sublimite, carbolic acid, etc.—is not to be advised, from the danger of retention and absorption.

Enemata for local effect are generally used in quantities of from two to six ounces, according to the age of the patient. The intestine should first be emptied by an ordinary saline irrigation, except when nitrate of silver is to be used, when simple water should be employed. The clyster is used about half an hour afterwards, slowly introduced, the buttocks being pressed firmly together to prevent escape of the injection. A compress should be held against the anus by a nurse for from twenty to forty minutes, according to the nature of the enema and the effect aimed at. For use in this manner the following substances are to be preferred:

1. Bismuth suspended in mucilage (ʒss to ʒi), from four to six ounces being injected, and retained as long as possible.

2. Tannic acid dissolved in water (gr. xx to ʒi), used in the same quantity and in the same way as the bismuth solution.

3. Nitrate of silver (gr. ii to ʒi): inject four ounces, and in five minutes follow with a copious saline injection.

To all of these tincture of opium should be added, the amount being about twice what a full dose by the mouth would be for the child's age.

Of these the first two are to be preferred. The silver injections stain linen so readily that they are not pleasant to give; and when used in considerable quantity harm may be done unless they are carefully made and followed by the saline. The bismuth and tannic-acid solutions may sometimes be used with advantage in quantities considerably larger than those indicated above.

4. Bland mucilaginous mixtures, such as starch, salep, etc., usually with an opium addition.

In general, intestinal irrigation is more useful than enemata. It is valuable in all varieties and in all stages. It may be combined with enemata. Small injections of four or six ounces fill the rectum and sigmoid flexure, but not much more. They are most valuable, then, when these parts are the chief seat of disease, as in the so-called dysenteric stools. In these cases they are of very great value, as are also small injections of ice-

water. For tenesmus when not relieved by these measures, suppositories containing half a grain of cocaine may be used, and sometimes act like magic. In subacute cases where the stools are not of the dysenteric type, we may safely assume that nearly the whole colon is involved, and our choice here is between simple irrigations and high injections of bismuth or tannic-acid solutions. Their use may be continued for several weeks with advantage, the character of the injection being changed from time to time.

During convalescence it is better generally to stop all treatment with reference to the bowels and to direct our efforts in the line of general tonic measures. The most useful tonics are arsenic, of which one or two drops of Fowler's solution may be given thrice daily for several weeks; iron, one of the best preparations for infants being the albuminate;\* nux vomica, which may be combined with either of the above; wine, either old port or sherry; this may be combined with a bitter if there is thought to be danger of forming a habit; mineral acids, especially the nitro-hydrochloric, two to five drops of the dilute acid being given after meals, largely diluted in water. Cod-liver oil had best be deferred until the stomach and appetite are quite in order, but it is well to continue it through the succeeding winter months.

---

## IX. CHRONIC DIARRHŒA.

Two forms of intestinal disease having chronic diarrhœa as a prominent symptom are excluded from the present section, because they are treated of in another part of this work,—viz., diarrhœa depending upon intestinal tuberculosis, and membranous enteritis or mucous disease. The remaining cases may be conveniently divided into two classes:

(1) *The primary cases*, in which there is often only a continued derangement of function, which after a time may induce anatomical changes (these changes may be absent; they are usually slight); the two principal etiological factors being depraved constitution and continued bad feeding. These cases commonly terminate in recovery when the cause can be removed.

(2) *The secondary cases*, in which the chronic disease follows an acute attack of entero-colitis, and in which there are usually very marked anatomical changes upon which the diarrhœa depends. The great proportion of these cases ultimately prove fatal.

### THE PRIMARY CASES.

**Etiology.**—This form of diarrhœa is exceedingly common in children who are the subjects of rickets, syphilis, general tuberculosis (even when not involving the intestines), chronic broncho-pneumonia, and, in fact, any

---

\* Prepared by Fraser & Co., New York. The dose is from ten to thirty drops for an infant.

chronic cachexia. It is seen very much more frequently in institutions than in private practice. It may occur at any season.

It is very much more common in artificially-fed infants, yet it is not rare in those who are nourished at the breast exclusively. Among the latter it is seen sometimes in the early months, where it may be due to the composition of the milk, to the presence of colostrum, or to the excess of albuminoids and salts and deficiency in fat and sugar. This is seen among very young mothers, and those who, though delicate and anæmic themselves, yet feel it to be their duty to nurse their children. They often succeed in keeping up a large flow of milk by drinking largely of all fluids, and especially of malted drinks. It may occur also from prolonged lactation, where this is kept up until eighteen or twenty months because the mother fears to feed the child during its "second summer;" and, finally, it may depend on the mother's becoming pregnant.

In artificially-fed infants it may depend upon the nature of the food, or upon the manner of feeding, especially upon too frequent feeding or upon overfeeding. (See general section on etiology.)

It sometimes occurs as a sequel of some of the eruptive fevers, as measles or scarlatina. It may complicate pertussis, especially in summer. Insufficient clothing, especially of the extremities and the abdomen, is undoubtedly sometimes an exciting cause in infants who are constitutionally predisposed to chronic diarrhoea.

One attack always predisposes to a second. In older children the principal causes, as in infancy, relate to constitutional condition and to habits of feeding. It is not uncommon among children of the better classes who are allowed to select their own articles of diet from the table, and who choose habitually indigestible articles, sweets, highly-seasoned foods, tea and coffee, salads, patties, nuts, preserves, and cake, instead of plainer and more wholesome articles. These habits are the more likely to give serious trouble if the children are delicate city-bred children, as, indeed, they usually are. Worms in the intestines, particularly ascarides, may be the cause of chronic diarrhoea.

**Symptoms.**—*In Infancy.*—In the early part of the disease there are often the symptoms only of dyspepsia, without any actual diarrhoea. The passages do not exceed three or four a day; they are semi-solid, often pale, putty-like, and have usually an offensive odor. They contain large quantities of undigested food; if white or gray this is largely fat, and the foul odor is due probably to the formation of fatty acids. There is usually some flatulence and colic, often tenesmus, and the stools if hard and dry may be streaked with blood. After a while mucus appears in considerable quantity and becomes a marked feature of the stools. The color varies from gray or brown to green or greenish yellow: these green mucous stools have usually less odor than the gray ones. Such stools may continue for two, three, or even six weeks before the mother or nurse is sufficiently disturbed to seek advice. This is often sought only because the child's general condi-

tion has begun to suffer, and the pallor, the anæmia, the flabbiness of the tissues, and the loss of weight have attracted attention. Even now, as Eustace Smith<sup>43</sup> very justly remarks, if questioned regarding the bowels the mother is apt to insist that they are regular or that they are "nicely open," and that there is no diarrhœa. The condition may be habitual almost from birth, or the change may come on so gradually that the mother often reaches the conclusion that these stools mean nothing in this particular case, especially if the infant happens to be teething. It becomes a physician's imperative duty to inspect personally the stools of every infant who is not thriving, no matter what statements are made regarding the character of the discharges.

It sometimes happens that the constitutional condition remains good, the child gaining steadily in weight, in spite of the fact that its movements are always greenish yellow or green and contain mucus and undigested food. I have known of one such case lasting for five months, the stools gradually becoming normal at the end of that time without treatment. This infant was nursed entirely by a remarkably healthy mother, and it is quite likely that overfeeding was the principal causative factor. Such cases are exceptional. In the vast majority of children—always, I think, in those artificially fed—we have after a few weeks pretty marked evidences that the general constitution is being seriously undermined. The appetite is frequently unimpaired.

As the case progresses the stools generally become more frequent and thinner, and they may vary almost endlessly in appearance, this depending largely upon the diet. They are often of a dirty brown, watery character, sometimes consistent and resembling chopped spinach, usually offensive, and always containing undigested food. The progress is never steady in cases of chronic diarrhœa. Every week or two, depending upon the state of the weather perhaps, or more commonly upon the food, there are acute exacerbations for a day or two, which, if severe, are sometimes accompanied with vomiting and fever.

The diarrhœa may continue until a state of extreme emaciation and cachexia is reached such as is seen in the secondary cases, and death may occur from exhaustion. Very few of them prove fatal *per se*; it is much more common for them to die from the supervention of some of the acute forms of diarrhœa. In summer this is almost the universal termination of the fatal cases. If a child is exhausted and wasted from a long-continued chronic diarrhœa it does not take a very severe acute diarrhœa to carry it off. In winter these cases die from other complications, usually bronchopneumonia.

In the cases going on to recovery, there is noticed first a diminution in the nervous symptoms, fretfulness, irritability, and restlessness at night. Then we see an improvement in the stools. They become more uniformly consistent and contain less mucus, although the offensive odor may last a much longer time; and finally the infants begin to gain in weight. This

gain is very slight at first, and may amount to only a few ounces each week. Convalescence is always protracted, and likely to be interrupted by relapses.

*In older children* chronic diarrhoea is seldom fatal unless dependent upon intestinal tuberculosis. But the cases are always obstinate, and peculiarly trying to the physician because of the great difficulty in removing the cause, which is generally pernicious habits of feeding.

There is here loss of flesh, not so rapid as that seen in infancy, and not usually so extreme; there are irritability of temper, restlessness at night, and a capricious appetite, especially a craving for sweets or highly-seasoned food. The children become pale and anæmic, droop perceptibly, and tire readily on exertion.

The stools are not very numerous, in the beginning only three or four a day. They are at first pale, sometimes clay-colored, and nearly always very offensive. They gradually become thinner, and contain mucus as a constant feature. They are now gray, brown, or green mixed with yellow, and always contain undigested food, sometimes but little changed. Eustace Smith points out a peculiarity of these cases,—that the stools are excited by the taking of food, which is hurried along the intestine with great rapidity before there is time for digestion or absorption.

The course of these cases is indefinite: they may last for months or even years, getting now better and now worse, with the diet, the season, and the surroundings. After they are once well, they relapse from very slight causes, and throughout childhood they may never lose their peculiar susceptibility to diarrhoeal attacks.

The general symptoms—loss of flesh and strength, and anæmia—are often seemingly out of proportion to the intestinal symptoms, so that some grave constitutional disorder is suspected, especially tuberculosis.

The foundation for rickets and for general or local tuberculosis is often laid by these attacks.

#### THE SECONDARY CASES.

Chronic diarrhoea may be preceded either by an attack of acute dyspeptic diarrhoea or by acute entero-colitis. If the former, it does not differ in its symptoms, course, or results from the cases which are primary and which have been just described. If the latter, it is much more serious.

These cases are usually seen in the fall months, and they comprise those which have barely managed to get through the summer months alive. No definite line can be drawn between the acute and the chronic stages. I shall include under the head of chronic cases all those which have lasted over six weeks, although some become chronic in a shorter time, and occasionally we see an acute case lasting longer.

In these cases the continuance of the diarrhoeal symptoms depends upon the existence of intestinal lesions.

The symptoms of active inflammation have passed away; the temperature is usually normal; there is no pain or tenderness; and food is taken readily, often with avidity. But there is no improvement in the general



condition, and either the weight remains stationary or the child loses steadily until it is little more than skin and bones.

*General Appearance.*—The face is pinched, the features sharp, the eyes sunken, and the cheeks hollow. The lips are pale, often fissured, and bleed readily. The fontanel is depressed. The body is so small that the head seems much too large. Almost every vestige of fat may disappear from the subcutaneous cellular tissue of the trunk and extremities. The skin hangs in loose folds on the thighs. The abdomen is sometimes distended and tympanic, and sometimes retracted and soft. The limbs seem like drumsticks.

*Mouth and Tongue.*—The mucous membrane of the mouth may be the seat of thrush, of simple catarrhal stomatitis, or of the follicular form, rarely of the ulcerative variety. The tongue is sometimes coated heavily, but is more often dry, glazed, and red. In rare instances sordes may cover the lips and teeth.

The teeth sometimes decay quite rapidly, from the general malnutrition. Baginsky states that the progress of dentition is arrested; but I have very often seen these infants—almost living skeletons—go on cutting tooth after tooth quite as steadily as under normal conditions, and Eustace Smith has made the same observation.

*Appetite.*—These children will, as a rule, take almost anything given them, and an almost unlimited amount. Yet, although they retain it, the more they are fed the more rapid sometimes seems the wasting. They rarely cry for food, however.

*Vomiting* is an uncommon symptom, and seldom occurs except from overloading the stomach, or from an acute exacerbation.

The *stools* are not frequent: five or six a day is about the average. Often they will drop to two or three a day for a week at a time. They are usually thinner than normal, but are not often watery. They invariably contain mucus, generally mixed with the other constituents and stained by bile. Blood is rarely present. The stools are sometimes green, often greenish brown, sometimes a pale gray. Undigested food is always present in quantity, and upon the diet depends very much the gross appearance of the stool. If milk is given, masses of fat and lumps of casein almost immediately appear in the passages. Vegetables come through often but little changed; so do the starches and cereals, and sometimes meat if this is given.

The odor of the stools is almost always offensive, sometimes extremely so. Nothnagel and Baginsky have called attention to one form of stools which they believe to be characteristic of wide-spread inflammation of the mucous membrane with atrophy of the tubular glands. These stools are of an almost normal consistence, homogeneous, in color like meconium, usually offensive, and sometimes alternating with those of a watery character. Under the microscope there are nuclei, but no unchanged epithelial cells. The food-remains are sometimes unrecognizable, from the extent to which decomposition has taken place.

Pus is nearly always to be found under the microscope, but is rarely visible to the naked eye.

*Prolapsus ani* is occasionally seen in these cases, though not so often as among the acute ones: when it does occur, however, it is generally more difficult to control, from the want of tone existing in all the tissues.

*Flatulence and colic* are marked symptoms in some cases, but absent altogether in many others. As a rule, there is neither abdominal pain nor tenderness. When the abdomen is enlarged it is most frequently uniformly so, but sometimes shows marked epigastric prominence, though from dilatation of the transverse colon rather than of the stomach. The skin of the abdomen often seems very thin; dilatation of the superficial veins is rarely met with. The liver and spleen are generally normal in size, so far as can be made out by physical exploration. Although the mesenteric glands are always enlarged, yet they cannot be felt through the abdomen. Enlargement of the inguinal and other groups of lymph-glands is mentioned by most writers as a symptom, but I have rarely seen any noteworthy swelling.

The *skin* is loose and wrinkled, dry and scaly, in the worst cases frequently covered with small petechiae on the abdomen and lower extremities. About the anus, and over the sacrum, the thighs, the genitals, and sometimes the feet, there is very commonly erythema, from the continued irritation, and not infrequently ulcerations are seen.

The *pulse* is weak and rapid, the peripheral circulation is poor, and the extremities are cold much of the time unless artificial heat is applied. The respiration is usually shallow, and often irregular without any apparent cause. It becomes rapid from the development of broncho-pneumonia, bronchitis, or marked hypostatic congestion.

The *temperature* is not elevated, except during exacerbations, or from the development of inflammatory complications. A subnormal temperature is occasionally met with, but is not very common. I have occasionally seen it 95° F. in the rectum, but rarely lower. A continuous subnormal temperature usually means death in a day or two.

The *urine* shows no constant changes. It varies in quantity according to the fluidity of the stools and to the amount of liquid taken. Dropsy in the feet may be present in the late stages without albuminuria.

The *nutrition and weight* are stationary, or steadily fall to an almost incredible degree. I have seen one infant weighing at thirteen months eight pounds; another at two years and four months, thirteen pounds. There are marked cachexia and extreme anæmia.

*Nervous symptoms* are always present, and sometimes are of a very puzzling character. The children are usually cross and irritable, sleep badly, and frequently have a low whining cry which is kept up much of the time. Sometimes they are dull, apathetic, and quite indifferent to their surroundings. Persistent opisthotonus is occasionally seen; sometimes there are contractures of the extremities and even general convulsions.

Ulcers of the cornea are not uncommon.

These cases last from two months to a year. Comparatively few survive more than four months. Their progress is irregular and marked by exacerbations and remissions. They die most frequently in some of these exacerbations or from complications, but sometimes of the disease itself, by a slow asthenia.

**Diagnosis.**—The existence of a chronic diarrhœa can be determined beyond any doubt by an inspection of the stools, but in this way only. The problem usually presented to the physician is whether the condition of the bowels is of itself a sufficient explanation of the general symptoms, wasting, etc., or whether there is some underlying constitutional disorder of which the diarrhœa is only one of the symptoms.

In the primary cases this can be decided only by carefully weighing the etiological factors as well as the symptoms. If the disorder is traced to poor breast-milk, to bad habits of feeding, or to improper food, and if the general condition has been previously good, it is pretty safe to assume that the intestinal disease is the one of most importance. If, however, the infant has never thriven, or if nothing wrong can be discovered in either the food or the feeding, and if the wasting preceded by some time the intestinal symptoms, we must look for some other cause. Rickets, syphilis, tuberculosis, and simple marasmus must one after another be excluded, and the child examined carefully from head to foot for evidences of disease in the brain, lungs, liver, and spleen. Especially must chronic broncho-pneumonia be looked for. Malaria is a rare cause of chronic diarrhœa. It may be suspected if there is known exposure, with marked splenic enlargement.

In the secondary cases it is very important to distinguish the cases in which the cachexia is quite marked and convalescence slow, although ultimately resulting in complete recovery, from those which, although presenting at a certain stage symptoms almost identical with the preceding, yet go on from bad to worse, terminating in extreme wasting and in death.

The difference in these cases is really a difference in the character and extent of the lesions. The former are probably the cases of acute follicular entero-colitis which do not ulcerate, or those of the superficial catarrhal variety, lesions capable of being entirely or almost entirely recovered from. The latter group are the cases of follicular ulceration or those of the severe catarrhal form of inflammation, in which there is no such thing as complete recovery from the lesions, and the reparative process, if any occurs, is only partial and cicatricial.

In distinguishing between these cases the most important guide is the nature of the symptoms during the antecedent acute attack. The longer the acute febrile symptoms lasted, and the higher the temperature, the greater the extent of the lesions and the more severe their character. This applies particularly to the cases of the catarrhal variety. The diagnosis of follicular ulcers has been already discussed under the symptoms of acute entero-colitis.

In any case of chronic diarrhoea, the longer the symptoms have lasted and the more profound the cachexia, the greater is the probability of the existence of important lesions. As in the primary cases, a disproportion between the intestinal and the constitutional symptoms leads us to seek for some other cause for the latter.

It remains to consider the diagnosis of chronic diarrhoea with wasting, from tuberculosis. This may be confounded with either the primary or the secondary form of diarrhoea, but much more often with the latter. The difficulty is much increased by the fact that in the secondary cases tuberculosis is not an infrequent sequel to the intestinal disease, especially where a constitutional predisposition exists.

The points in common are the existence of diarrhoea (which occurs in almost all the cases of general tuberculosis in summer, apart from the existence of intestinal tuberculosis), the wasting, the anæmia, the cachexia, the signs of consolidation in the lungs, which in one case may depend upon broncho-pneumonia and in the other upon tubercular deposits, and the nervous symptoms,—those of chronic entero-colitis sometimes simulating very closely those of tubercular meningitis.

In simple entero-colitis both the previous condition of the child and the family history are more likely to be good than in tuberculosis. It is not to be understood, however, that the failure to obtain any history of tuberculosis in the family is to have any special weight in deciding this question. Tuberculosis is more likely to be met with in institutions and among the poor of cities than in the country. Yet how frequently this occurs among children in the country we do not know, from the fact that almost no autopsies are made there.

In chronic entero-colitis the wasting and anæmia follow the intestinal symptoms and are usually just in proportion to their severity; in tuberculosis we often see improvement in the intestinal symptoms and yet progressive anæmia and wasting.

The abdomen in entero-colitis is more frequently natural or retracted, while in tuberculosis it is oftener distended.

The spleen is rarely enlarged in entero-colitis; it is very frequently so in tuberculosis. The presence of marked enlargement is a strong point in favor of tuberculosis. A general enlargement of external glands makes entero-colitis much less probable than tuberculosis.

The cerebral symptoms of entero-colitis are, as a rule, less constant and less regular than those of tubercular meningitis, and rarely so profound. Localized paralyses are very common in meningitis; they are very rare, if indeed they ever occur, in entero-colitis. The fontanel in meningitis is tense and bulging; in entero-colitis it is depressed.

As regards the physical signs in the chest, broncho-pneumonia complicating chronic entero-colitis affects with great uniformity the posterior borders and lower lobes of both lungs. Pulmonary tuberculosis in infants has no regular distribution, but affects the upper lobes rather more frequently

than the lower. The existence of much dry pleurisy renders tuberculosis more probable. If a cavity is found, this is almost conclusive, but not quite so. I have seen a non-tubercular cavity in a broncho-pneumonia secondary to entero-colitis.

Of single symptoms the most important differential one is fever. This is rarely absent in general tuberculosis, although its course is very irregular. If there is tubercular ulceration of the intestine, fever is probably always present. Fever is usually absent in chronic entero-colitis, except from complications, and from the occasional acute exacerbation.

It is by taking all the points of the case into consideration, rather than by reliance upon any single symptom, that the differential diagnosis is made.

Tuberculosis exists as a sequel of the cases of chronic entero-colitis very much more frequently than any one would imagine who does not have an opportunity to see the autopsies of the fatal cases.

**Prognosis.**—In general this depends upon the cause of the diarrhœa and upon our ability to remove it.

In the primary cases it is much worse among young infants than in those over two years old. It is worse when the symptoms have lasted some time and when they are continuous, better where they are intermittent. If there is some evident cause which can be removed,—such as improper food or feeding, or bad surroundings,—the prognosis is much better than when no cause is discoverable except the child's delicate constitution. It is worse when there is rickets, syphilis, or other constitutional vice. The existence of chronic diarrhœa increases the danger from any acute disease,—bronchitis, pneumonia, and the eruptive fevers,—and greatly adds to the liability to attacks of acute intestinal disease. It is, consequently, much more serious in summer than in winter.

In the secondary cases the prognosis depends upon the child's previous constitution, upon the duration of the intestinal symptoms, upon our ability to carry out proper treatment, like change of air, etc., upon the presence or absence of complications, but, most of all, upon the severity and extent of the intestinal lesions. The recognition of these has already been discussed under Diagnosis. The possibility of error always exists in estimating the gravity of the lesions, so that no case should be considered hopeless. Every physician who sees much of this form of disease has again and again met with cases so weak, so wasted, and so anæmic that recovery seemed out of the question; and yet after a few weeks under favorable circumstances they have begun to improve little by little and finally have gone on to complete recovery.

If, however, continuous symptoms have existed for eight or ten weeks without any sign of amelioration, recovery is very doubtful. There may be some improvement and the case may linger for two or three months longer, only to be carried off by the first attack of acute illness which occurs.

**Treatment.**—In the matter of prophylaxis there is only one point

deserving special emphasis, and that is proper clothing for the feet and legs of infants at all times, and especially in fall and spring: in the winter they are generally sufficiently protected. The abdomen should be protected by a flannel band, except in midsummer. The other points in prophylaxis are sufficiently dwelt upon in the general section.

In the successful treatment of chronic diarrhoea, either in infants or in older children, almost everything depends upon general management, hygienic and dietetic, and almost nothing upon drugs. These cases are generally very much overdosed, greatly to their detriment.

In the primary cases in infancy we first seek to find and remove the cause. If it is poor breast-milk, the child must be weaned, unless a good wet-nurse can be obtained. If prolonged lactation is the cause, or pregnancy, nursing must be stopped at once. Proper food in these cases will often stop a very intractable diarrhoea in a few days without a dose of medicine, where all the routine of drug treatment has been gone over without the slightest benefit. In the same way, if the cause has been habitual overfeeding, improper food, or bad habits of feeding, it is useless to attempt to do anything by drugs unless the cause can first be removed. If there be associated rickets, syphilis, or malaria, these must receive their appropriate constitutional treatment.

In all cases in infancy rooms should be kept at an equable temperature in winter, and not too warm; plenty of fresh air must be allowed. There is no advantage in keeping the child in-doors unless it is extremely delicate or very young, or unless the weather is very cold or stormy. In going out it should be well protected, and the feet kept warm by a hot-water bag. In summer the child should certainly have the benefit of a change of air whenever this is possible. It should be sent from the city to the country, not merely for the sake of its chronic diarrhoea, but to escape as far as possible the dangers of acute attacks. The regions mentioned as proper for acute attacks are equally well suited to the chronic ones.

There should always be sufficient clothing to protect well the feet and legs.

The dietetic rules to be followed do not differ from those given for acute dyspeptic attacks after the first stage of severe symptoms has passed,—viz., breast-milk whenever it is possible; cow's milk used very sparingly, and never except it is well diluted or completely peptonized; if then the fat or curds appear in the stools as a constant thing, milk must be stopped altogether, and whey, broths, barley gruel, or some of the malted foods tried.

There is always a tendency to overfeeding, as these children's appetites are usually good and they will take almost any amount of food that is offered. Underfeeding is better than overfeeding. The object should be to maintain the nutrition of the child with the smallest irritation possible to the intestinal canal. We select our food, so far as we can, with this in view. Foods which leave the least residue are usually the best.

In older children an exclusive diet of boiled milk sometimes is exceed-

ingly well borne. This may be thickened with barley flour or with "flour ball." As a rule, starches must be given rather sparingly, and combined with malt. If milk is not well borne, the animal broths, meat jelly, beef juice, and even raw scraped meat, may be tried. Monotony of diet is, if possible, to be avoided.

The use of drugs is of secondary importance: the routine use of opium and astringents, especially the tannin preparations, does more harm than good. We must husband our resources, and do nothing which would in any way disturb stomach-digestion. Antacids and aromatics are useful where there is acid fermentation of the stomach. An occasional cathartic dose of calomel or of castor oil, to sweep out the canal, is of great benefit. Pepsin, hydrochloric acid, and extractum pancreatis (Fairchild's) serve a very useful purpose. Opium is to be used occasionally when demanded by special symptoms, especially frequent watery movements, and also in cases where passages from the bowels follow almost immediately upon the ingestion of food.

Bismuth by the mouth is of value in the case of thin watery movements, but does less good when the movements are consistent and infrequent. I have little faith in the other mineral astringents.

Antiseptics are not of very great value in these chronic cases. If there is much flatulence, with offensive stools, these symptoms may be allayed often by salicylate of sodium or by salol.

Stimulants must be used in a very large proportion of the cases.

Irrigation of the bowel is of a certain amount of value, but much less than in most of the other varieties.

Arsenic and nux vomica are highly spoken of by Eustace Smith in many of these cases, especially during convalescence. I have rarely seen from their use the striking benefit of which he speaks.

In the secondary cases the treatment is virtually a continuance of the measures employed in the acute stage of entero-colitis. The children must be sent inland,—to the mountains if possible. The same dietetic rules apply as in more slow acute cases. Not much is to be expected from drugs. It is of no use to give these children week after week the various popular diarrhœa-mixtures, with the expectation that ultimately the formula which exactly meets the wants of the particular case will be found. The occasional use of opium is required by special symptoms,—*e.g.*, frequent thin movements. Bismuth is about the only other drug which can be said to have any influence on the lesion; but it must be given, as in acute cases, in large doses,—two to three drachms daily. Even bismuth should be stopped for a few days every week or two, to see how the stools are without it. An occasional dose of castor oil or of calomel is beneficial, and in a few cases the use of the smaller doses of oil (℥v to ℥x) in emulsion, four or five times daily, seems to be of advantage. It should not be continued more than two or three days unless very manifest improvement occurs, from the danger of disturbing the stomach.

Astringent enemata are of considerable value. We can hope to do very

much more in the treatment of these lesions by this means than by drugs given by the mouth. Enemata should be used once a day, but should be discontinued for a few days every week or two, to see what the condition of the stools is without them. In using these the method should be practised, already described in the treatment of acute cases, of first irrigating the whole colon thoroughly with either plain lukewarm water, or a salt solution (a teaspoonful to a pint), or a borax solution of the same strength. In this way mucus, fecal matters, etc., can be removed, and the astringent solution brought in direct contact with the mucous membrane.

The astringents to be used are tannic acid, bismuth, and nitrate of silver, their ratio of value being in the order named. The same strength of solution as in the acute cases may be employed. They should be lukewarm, or they will be quickly expelled. Where irrigation and astringent enema are to be used for a long time, as several weeks, there is a decided advantage in changing the astringent every week or ten days.

Complications should always be watched for: they are to be treated on general principles as they arise.

In some of the secondary cases, especially if the symptoms have lasted eight or ten weeks with little or no change, we get the best results by directing our entire efforts towards the general cachexia and stopping all intestinal therapeutics. Alcoholic stimulants must be used in almost all cases, and they may be kept up for a long time with advantage. Old port or sherry will sometimes do better than brandy or whiskey. Usually we give that which the patient will take most readily. The predigested foods are of much value; so also are the beef preparations, bovine, beef peptonoids, and meat extracts; raw meat may be used with benefit.

Massage is also of real value in some of these cases. Inunctions of cod-liver oil may be used, or other forms of fat.

Where there is a failure in the absorption of fats, I have seen beneficial results follow Reed & Carnrick's combination of pancreatin and bile known as panerobiline. It is given in pills coated with keratin to older children from one and a half to two hours after feeding. In infants the liquid preparation may be substituted, half a drachm to a drachm being given one hour after feeding, not more than three times a day.

In general, in the treatment of the secondary cases of chronic diarrhoea the patient must first be put in the best possible surroundings,—in no cases does a change of air do more; minute and careful attention must be given to diet, and the effects studied by the stools and the weight; in respect to diet each case must be studied by itself; intestinal irrigation offers much better chances of success in treating the lesions than drugs by the mouth; it is sometimes better to ignore the intestinal lesions and seek to promote the general nutrition by all possible means. These cases are always trying ones to the physician. Unless he can control absolutely the matter of diet, it is hopeless to attempt to do anything. Still, by careful study of the individual case, and minute attention to details, especially in dietetics, success



may sometimes be achieved even in the cases which seemed at the outset the most desperate.

The danger of relapses and second attacks continues for many months. During the summer following such an attack, the child should be sent where it will be least likely to suffer from further attacks of diarrhœa.

## BIBLIOGRAPHY.

1. TOMPKINS, HENRY. The Etiology of Summer Diarrhœa. *British Medical Journal*, July 27, 1889.
2. VACHER, FRANCIS. Is Summer Diarrhœa one Disease or many? *British Medical Journal*, September, 1885.
3. MEINERT, E. Untersuchungen über den Einfluss der Luft-Temperatur auf der Kindersterblichkeit an Durchfallkrankheiten. *Deutsch. Med. Wochenschr.*, June 14, 1888.
4. BAGINSKY, A. Die Verdauungs-Krankheiten der Kinder. Tübingen, 1884.
5. HOPE, E. W. Infant Diarrhœa. *Liverpool Medico-Chirurgical Journal*, January, 1887.
6. BALLARD, EDWARD. *British Medical Journal*, 1883, ii. 363.
7. BARUCH, S. The Etiology and Treatment of Summer Diarrhœa in Infants. *The Medical News*, July 7, 1888.
8. HOPE, E. W. Etiology of Infantile Diarrhœa. *Liverpool Medico-Chirurgical Journal*, July, 1885.
9. LESAGE, A. De la Dyspepsie et de la Diarrhée verte des Enfants du premier Age. *Revue de Médecine*, Dec. 1887, and Jan. 1888.
10. BALLARD, EDWARD. *The Lancet*, May 4, 1889.
11. SEIBERT, A. Cholera Infantum and the Weather. *The Medical Record*, March 24, 1888.
12. MILLER, T. C. Cholera Infantum and the Weather. *The Medical Record*, July 21, 1888.
13. VAUGHAN, V. C. The Causation and Treatment of Summer Diarrhœa in Infancy. *The Medical News*, June 9, 1888.
14. KINNICUTT, L. P. Tyrotoxicon in Milk. *Boston Medical and Surgical Journal*, January 17, 1889.
15. ESCHERICH. Die Darmbakterien des Säuglings. Stuttgart, 1886.
16. MILLER, W. D. *Deutsch. Med. Wochenschr.*, 1884, p. 781; 1885, p. 843; 1886, p. 117.
17. VAN PUTEREN. Über die Microorganismen im Magen von Brustkindern. *Deutsch. Med. Zeitung*, October 22, 1888, from *Wratch*, Nos. 21, 22, 1888.
18. MACFADYEN. *Journal of Anatomy and Physiology*, 1887, pp. 227 and 413.
19. PRUDDEN, T. M. Studies on the Etiology of the Pneumonia complicating Diphtheria in Children. *American Journal of the Medical Sciences*, June, 1889.
20. WOODWARD, J. J. Medical History of the War of the Rebellion. Part II.
21. NOTHNAGEL, H. Beiträge zur Physiologie und Pathologie des Darms. Berlin, 1884.
22. SELLEW, F. S. Report of the Proceedings of the New York Pathological Society. *The Medical Record*, April 20, 1889.
23. KJELLBERG. Parenchymatöse Nephritis im frühen Kindesalter. *Journal für Kinderkrankheiten*, 1870, p. 192.
24. KELSCH. Contributions à l'Anatomie pathologique de la Dysentérie chronique. *Archives de Physiologie*, July and September, 1873.
25. UFFELMANN, J. *Deutsche Archiv für Klin. Med.*, 1881, Bd. xxviii.
26. WEGSCHEIDER. Die Normale Verdauung bei Säuglingen. Berlin, 1875.
27. PFEIFFER, E. Die Verdauung im Säuglingsalter bei krankhaften Zuständen. *Jahrb. für Kinderheilk.*, Bd. xxviii. S. 164.

28. DEMME, R. Über Fettdiarrhöe der Säuglinge. Jahresbericht des Kinderspitals in Berne, 1877.
29. BIEDERT, PH. Über Fettdiarrhöe. Jahrb. für Kinderheilk., 1878, Bd. xii. S. 197.
30. LAMBL. Microscopische Untersuchung der Darm-Excreta. Prager Viertelj., 1859, Bd. i., and Aus der Franz-Josef-Kinderspitale in Prag, Th. i., 1860.
31. VON JAKSCH, R. Ueber das Vorkommen von thierischen Parasiten in den Faeces der Kinder. Wien. Klin. Wochenschr., September 20, 1888.
32. ESCHERICH, TH. Beiträge zur antiseptischen Behandlungsmethode der Magen-Darmkrankheiten des Säuglingsalters. Jahrbuch für Kinderheilk., Bd. xxvii. S. 126.
33. BAGINSKY, A. Gährungs-Vorgänge im kindlichen Darmcanal. Deutsch. Med. Wochenschr., Nos. 20, 21, 1888.
34. EHRLING, J. Die mechanische Behandlung der gastrointestinalen Katarrhe der Säuglinge. Jahrb. für Kinderheilk., Bd. xxvii. S. 258.
35. EPSTEIN, A. Magenausspülung bei Magen- und Darmkrankheiten im Säuglingsalter. Jahrb. für Kinderheilk., Bd. xxvii. S. 113.
36. GOELET, A. H. Salol in Diarrhœa. New York Medical Journal, August 6, 1887.
37. OSBORNE. New York Medical Journal, April 7, 1888.
38. MONCORVO. Annual of the Universal Medical Sciences, 1889. Vol. i. E 24.
39. WIDERHOFER, H. Magen-Darmkrankheiten, Gerhardt's Handbuch der Kinderkrankheiten. Tübingen, 1880.
40. HENOCHE. Berlin. Klin. Wochenschr., Nov. 26, 1888.
41. SEVESTRE. Correspondence in Journal of the American Medical Association, July 28, 1888; Debove, Provincial Medical Journal, September 1, 1888.
42. SMITH, EUSTACE. Wasting Diseases of Children. 4th edition, New York, 1885.

# MEMBRANOUS ENTERITIS.

BY WILLIAM A. EDWARDS, M.D.

---

**Synonymes.**—Pellicular colitis, Intestinal cast, Pseudo-membranous enteritis, Intestinal desquamative catarrh, Mucous disease, Chronic mucocolitis, Chronic croup of the intestines, Chronic pellicular inflammation of the intestinal mucous membrane, Fibrinous diarrhœa, Follicular, Duodenal, and Colonic dyspepsia, Chronic pseudo-membranous gastro-enteritis, Tubular looseness, Tubular exudation-casts of the intestine, Mucous or Gelatinous diarrhœa, Mucous casts; Latin, *Diarrhœa febrilis*, *Diarrhœa tubularis*, *Hypochondriasis pituitosa*; French, *Entérite interstitielle*.

The term membranous enteritis has within the last few years become restricted in its application to a particular form of intestinal disorder, characterized by irregularly recurring paroxysms of abdominal pain, unaccompanied by fever and relieved by the passage of membranous shreds or tubes, which for the most part are composed of mucin. In this article it is not our purpose to deal with cases in which the passage of the membrane is accompanied by all the symptoms and concomitants of enteritis or entero-colitis in their acute or chronic form, but rather with cases in which the passage of the membrane is about the only symptom presented, or at least is the most marked feature of the disorder.

It has been recognized for many years that a mucous substance may be voided by stool, but it is only recently that these cases have received careful attention and proper classification. At first these membranous shreds and tubes were considered to be portions of the intestinal canal, but Fernelius in 1554, Van Swieten, and Sennertus all recognized their true nature and so recorded them. Still later Morgagni further described the disease; he considered the membranes to be due to the fact that the pituitous humor became concrete and adhered to the inner coat of the intestine. Within the last few years able and careful papers have been written by several observers, to which I have already called attention.<sup>1</sup>

**Etiology.**—The most varied and opposite etiological factors have been adduced in endeavoring to arrive at a true understanding of the causative agents in producing the condition sometimes styled tubular diarrhœa, a

---

<sup>1</sup> Amer. Jour. of Med. Sci., April, 1888.

not inapt designation. We, however, definitely know that climate, occupation, and inheritance are not to be considered as predisposing causes of the disease.

It is undoubtedly a fact that most cases occur in young adult females who are hysterical, or at least of a nervous disposition; but recently sufficient cases have been recorded among children to merit consideration in a work such as this, remembering, however, that the disease is not a frequent one in children. In one hundred and eleven cases six were under the age of ten.

Clemens<sup>1</sup> reports four cases as occurring in children; Chapin<sup>2</sup> records other cases, as does also J. Lewis Smith;<sup>3</sup> Whitehead<sup>4</sup> adds two children to the list. Laget<sup>5</sup> has observed an infant convalescing from diphtheria who passed a mucous cast nearly eight inches long, and Barrier<sup>6</sup> an example of the disease in a child of five years.

**Sex.**—Sex does not seem to be the same predisposing element in children that it undoubtedly is in adults, when we can say that the majority of cases are seen in hysterical women; for example, eighty per cent. of the recorded adult cases occurred among females.

The disease is apt to be either a concomitant or a sequel of disease of the genital or the intestinal tract or of the nervous system: most observers report an antecedent dyspepsia and constipation alternating with diarrhœa. Grantham has considered the abuse of mercury to be productive of the condition. In a child it may follow typhoid fever, enteralgia, hemorrhoids, or tuberculosis of the intestine.

We must exclude from consideration the membranes passed in the so-called croupous or diphtheritic enteritis, as it has not been allotted to us to consider all forms of membranes passed, but simply that form which is purely a mucous cast.

Da Costa attributes the etiology to the nerves presiding over nutrition and secretion, considering the disease to be a manifestation of disordered nervous supply, which may be either general or local. Wales considers the ganglionic nerves of the intestine to be primarily at fault; most cases will certainly present marked evidences of deranged nervous action.

**Symptoms.**—The passage of the casts is usually paroxysmal, accompanied by abdominal pain, tenesmus, and nervous disturbances, and preceded or followed by digestive troubles. Abdominal tenderness almost always exists, and is generally relieved by the passage of the membranes; blood may be present in the discharges; at this time the bladder will usually

---

<sup>1</sup> Ueber dem Darmkrup der Kinder, Jahrb. für Kinderkrankheiten, 1860, Bd. xxxiv. S. 30.

<sup>2</sup> Archives of Pediatrics, 1884, vol. i. pp. 447-49.

<sup>3</sup> Diseases of Infancy and Childhood, 4th ed., p. 437.

<sup>4</sup> Med. and Surg. Rep., Manchester Hosp., 1870.

<sup>5</sup> Bull. Soc. Anat., Paris, 1875, p. 843.

<sup>6</sup> Traité pratique des Maladies de l'Enfance, 2d ed., 1845, t. ii. p. 36.

present some symptoms or evidences of sympathizing in the disorder, more particularly should the disease occur in a female at or after puberty, when manifestations of uterine disorder will be almost invariably present.

Patients who are the subjects of membranous enteritis, while they do not lose the normal contour of the body, still present some evidences of malnutrition. They are apt to have eruptions of furuncles and carbuncles, sore mouth, or herpes of the genitals, and an irritable nervous system. Emaciation is rarely a marked symptom: indeed, it is worth noting that this almost complete lack of emaciation persists throughout the course of the disease, notwithstanding the amount of matter passed.

The number of paroxysms is very variable: patients are sometimes able to foretell an attack by certain symptoms, as chilliness, blueness of the nails, and tingling or pain at the finger-tips. A person the subject of this disease may suffer but one attack in a year, or but one a month, or, on the other hand, the paroxysms may be continuous, as in one of my own cases. The duration of the attacks is also very variable: they have been reported as short as twenty-four hours and as long as two weeks. The difficulty of precisely limiting the attack will be appreciated when it is remembered that in the more chronic cases there is an almost constant sequence of symptoms. It must also be borne in mind that the patients are usually dyspeptic and suffer more or less from constipation and from abdominal distress which sometimes amounts to severe pain referred to the umbilical region; indeed, this train of symptoms usually precedes for some time the expulsion of the membranes. Membranes are not found in each stool during a paroxysm, as a rule, but a single accumulation is generally passed, accompanied by pain and tenesmus; indeed, some cases discharge the membranes only about once a week; on the other hand, patients may have ten or a dozen membranous stools in twenty-four hours.

Pain, tenderness, and tenesmus are complained of in varying degrees by different patients. The most usual manifestation is abdominal pain, which may be simply a sense of uneasiness or may be agonizing pain which is generally relieved by the passage of the membrane. Tenderness may exist over the entire abdomen, or may be localized and developed only by firm pressure.

Hemorrhoids, prolapse of the rectum, diarrhoea, jaundice, extreme thirst, coated, anæmic, and fissured tongue, aphthous ulcer of the mouth, and tonsillar phagedæna have all been noted in the symptomatology of the disease.

The nervous system presents many and varied manifestations. To some of these neuroses we have already called attention, particularly the hysterical derangements, which are the most frequent of all the functional disturbances. The following symptoms have been noted: neuralgia, hyperæsthesia, anæsthesia, irregular muscular tremors, paresis, hysterical tetanus, and coma; convulsions have also been observed. Transient defects in vision, tinnitus aurium, and disordered sense of taste are also among the recorded symptoms.

Whitehead has noted chorea and paralysis, and Copeland has observed a cataleptic condition, follow an hysterical outbreak. Cerebral symptoms have occasionally appeared: for instance, amnesic aphasia has been recorded; mental depression, faulty memory, hypochondriasis, and melancholia may be exhibited for a time, to be followed possibly by increased mental activity.

The temperature is rarely above normal, except possibly during the height of a paroxysm which is accompanied by much pain; it may, however, be affected by an intercurrent disease, as phthisis.

**Microscopic Appearance of the Membranes.**<sup>1</sup>—They are for the most part made up of opaque white, solid masses, rounded or flattened, and small flocculent pieces of semi-translucent membrane; the membranes are delicate, and out of water are handled only with the greatest difficulty.

Under a ten-inch objective their surface is seen to be composed of opaque and translucent parts, the former apparent as rounded ridges marking off the latter into regularly-arranged hexagonal or polygonal crypts; under a higher power these crypts are still visible, although much less defined. These appearances are seen best in small flakes of membrane, less distinctly in the larger masses, and not at all in the finer net-works that are sometimes passed.

These masses of membranes appear to be due to the formation of mucous and epithelial matter either upon the surface of or in contact with some follicular mucous membrane. This view is evidenced by the nomenclature of the Philadelphia Pathological Society, which, for example, considers the membranes to be the product of an "interstitial desquamative catarrh." On comparison of these membranes which are moulded by the gut with the healthy mucous membrane, certain differences are at once apparent: the mouths of the pseudo-follicles on the surface of the cast are much larger than those in the normal intestine; they approach closer to one another, and may run one into the other; the cells present in the membrane have no definite arrangement, and are not placed upon a basement-membrane, which is entirely absent in the mucous formations. The cells have undergone a fatty disintegration.

Mills and Clark tell us that, upon laying the cast open and examining its inner surface under a power of forty diameters, a gelatinous membrane-formed matrix was observed, traversed by a coarse net-work of opaque yellow lines and studded at other points of intersection by similarly-colored roundish masses; from the large net-work proceeded a smaller net-work, and in its meshes were formed, at close and regular intervals, well-defined oval or round openings, with elevated margins, looking like the mouths of the follicles in the large bowel. Under a power of three hundred and fifty diameters the matrix was transparent, structureless, elastic, and

---

<sup>1</sup> Specimens of the membranes are preserved in several museums, to which I have referred in a communication to the Philadelphia Medical News, August 7, 1886.

everywhere free from fibrillation. Embedded in it were granules, free nuclei, cells, crystals, and particles of undigested food. The opaque yellow lines were seen to be composed of foreign matters, as bile-pigment, earthy and fatty granules, portions of husks of seeds, gritty tissue of pear, a peculiar form of elastic tissue, stellate vegetable hairs, and a mucedinous fungus. The cells in the matrix were either spherical or cylindrical,—in some portions lying without obvious order, in other parts arranged in layers. Generally the membranes consisted of a single layer of matrix with cells, but in some places several layers of matrix could be noted.

Andrew Clark, in a supplementary note, takes exception to the above report. After citing several propositions to prove his hypothesis, he concludes that he is justified in stating that the casts or membranes are not fibrinous, that they are not the product of inflammation in the sense defined (chronic inflammatory action of the mucous membrane, and subsequent exudation), and that the abnormal cell-products have arisen in some other way—*i.e.*, metamorphosis—than by free development of an exuded blastema. He also makes the further observation, which is of extreme interest in the present study,—*viz.*: the product of diseased action in mucous membranes occurs in three varieties: first, clear, jelly-like, and imperfectly membranous; second, yellowish, semi-opaque, flaky, and usually membranous; third, yellowish white, dense, opaque, distinctly membranous, tough, and rather adherent to the subjacent surface.

**Action with Reagents.**—H. B. Hare states that pharyngeal mucus, for example, will exhibit chemical reactions similar to those of the membranous discharges, and states, further, that the discharges consist essentially of mucin, with possibly a trace of albumen, and no fibrin,—thus confirming my own views on the subject and agreeing for the most part with all other observers.

Strong acids and alkaline solutions of moderate strength will dissolve the casts. Their albuminous nature is further shown by acting on these solutions with the usual tests for albumen,—heat and nitric or acetic acid. Some observers (Clark) have noted the absence of albumen in the membranes.

According to Goodhart, after the solution has been precipitated it cannot be reprecipitated by acetic acid, ferrocyanide of potassium, alcohol, ether, or perchloride of mercury. The casts stain readily but irregularly with carmine.

**Pathology.**—The colon seems to be generally the selective site of the disease; this, however, is not always the case, as the small intestine may be invaded, either in conjunction with the colonic deposit or altogether independently of it. Upon referring to the literature of the subject, one is at once struck with the extreme paucity of post-mortem records of the disease; and if we exclude all cases of croupous or diphtheritic deposit the number becomes small indeed.

Simpson says that Abercrombie saw a case in which the mucous mem-

brane of the colon was covered by an immense number of clear white spots, which were small vesicles that when punctured discharged a small quantity of clear fluid; the patient during life had passed a large quantity of membranous casts or tubes. The small intestine was healthy. The girl died of phthisis.

Da Costa is of the opinion that the affection is not originally an inflammation, considering the inflammatory element to be the result rather than the cause. Clark held that the membranes were not the product of inflammatory action, because they contained no fibrin, a view that is not tenable at the present day, because we know that fibrin is not an essential component of an exudate. My own views are in accord with the general opinion that if inflammation is present at all it is in a very mild form. Siredey, Wales, and Whitehead all practically agree that the pathogenesis of the affection is to be looked for in the nervous system; indeed, as Da Costa aptly remarks, "the association often with similar discharges from other outlets points to a deeper, more general cause than enteritis or a morbid condition of the intestinal mucous follicles." Barrier noted alteration in the follicular apparatus of the intestine.

**Diagnosis.**—The diagnosis of this condition presents few, if any, difficulties. If mistakes arise they are, in all probability, due to the carelessness of the observer rather than to any obscurity in the manifestations of the usual clinical phenomena of the disease. The writer has known observers to consider the membranes to be *ascaris lumbricoides*: the resemblance in some cases is close, indeed, but they are readily distinguished by even a casual examination. Again, the white, shining, detached pieces have been mistaken for segments of *tenia mediocanellata*, *tenia solium*, and *bothriocephalus latus*; but, as above stated, the failure to recognize the nature of the disease is not on account of its atypical manifestations. It has also been mistaken for fatty discharges and for the lienteric discharges of dysentery. Anal fissure may cause a hypersecretion of mucus.

In cholera a fibrinous or gelatinous matter has been noticed in the small intestine; in some cases this has taken the form of a croupous deposit. In scarlatina and in tubercular disease a membrane occasionally forms and is cast off.

That adult patients may inadvertently be misled, and thus mislead their medical adviser in relating the history of their complaint, is proved by the experience of Quekett, quoted by Richard Quain, who records the case of a patient who at intervals of two or three weeks had severe abdominal pain, occurring in paroxysms, always relieved by the passage of a mass, sometimes as large as an orange, or larger, made up of membranous matters and tubes. The mass represented the undigested portion of mutton-chops upon which the patient had been living. Quekett further states that he has observed nine cases of a similar character. Schubler<sup>1</sup> gives a plate illus-

<sup>1</sup> *Jahrbücher d. Deut. Med. u. Chir.*, Nürnberg, 1813, Bd. iii. Heft i. S. 66.



trating peculiar branching tubes passed per rectum, which were also probably the arteries and ligaments derived from the meat diet of the patient; and similar cases are reported by Elsässer and Uhl. In other cases the membranes appear to be made up entirely of yellow elastic tissue which, according to Corrigan,<sup>1</sup> resembles closely the ligamentum nuchæ of sheep.

In conclusion, portions of the gut itself<sup>2</sup> or its necrosed mucous membrane may be voided by stool; but the history of the case, and the constitutional condition of the patient, with the concomitants and the appearance of the matter passed, should quickly elucidate the nature of the disease.

**Prognosis.**—The prognosis in relation to cure is bad: most cases run a prolonged and tedious course, in many patients extending over the larger part of adult life. The disease of itself, uncomplicated, rarely proves fatal; the recorded causes of death are totally independent of the membranous affection.

**Treatment.**—We may consider the treatment under two headings,—the prophylactic and the active, or that which is appropriate during an interval or remission, and that which we resort to during an exacerbation. It is during the intermissions that we can hope to do more for our patient's permanent good than during an actual attack: it is then that diet, regimen, and hygiene are of greatest importance. There must be a careful supervision of the patient's daily life. All sources of irritation are to be removed. Easily-digested or even pre-digested food should be supplied, and care should be taken to ascertain that undigested particles of food are not irritating the intestinal canal. As constipation usually exists, sometimes to a stubborn degree, mild saline laxatives are generally most efficacious; enemata or glycerin suppositories may be resorted to.

During the acute stage of an attack opium will often be found necessary to afford relief, and possibly to check excessive secretion or hemorrhage. Belladonna in the form of extract, Dover's powder, and subnitrate and subcarbonate of bismuth, with local counter-irritation, all tend to abort the paroxysm or at least to shorten its duration. The following remedies have been suggested: arsenic, copaiba, bromide of potassium, nitromuriatic acid, henbane, vegetable infusions, prolonged counter-irritation, electricity, turpentine, iron, cod-liver oil, oxide or nitrate of silver by mouth or by high injection into the bowel, chloride of ammonium, sulphate of zinc, bichloride of mercury, chlorate of potassium, oxide of zinc, blisters, warm-water enemata, nux vomica, ergot.

Exercise for the growing child who is robust enough to bear it is of paramount importance, and, if possible, should be out of doors: hence a mild, equable climate should be selected for the little patient, one in which he may pass the greatest number of days in clear sunshine and surrounded by a balmy atmosphere.

<sup>1</sup> Dublin Hospital Gazette, 1854-55, vol. i. p. 38.

<sup>2</sup> Ziemssen's Cyclopædia, Boehm, vol. xvii. p. 332.

# INTESTINAL BACTERIA OF CHILDREN.

By WILLIAM D. BOOKER, M.D.

---

**Definition.**—Bacteria are small, globular, rod-shaped or spiral, unicellular organisms, which increase by transverse division. Bacteria are divided into micrococci, bacilli, and spirilla. Micrococci are spherical or slightly oval, no difference being recognized in length and in breadth. Bacilli are rod-shaped, the length exceeding the breadth. Bacilli curved on the long axis are called comma bacilli, and a chain of them constitutes a spirillum. But there are also spirilla, or long spiral threads, which show no division into commas. The same species of bacillus may show considerable variation in the length and size of individual rods, but there is no satisfactory evidence to prove that a bacillus changes into a micrococcus, or a micrococcus into a bacillus.<sup>1</sup>

**History.**—The occurrence of bacteria in the feces has been known for many years, but no practical advantage was derived from this knowledge until the recent introduction, by Koch, of methods for isolating bacteria and studying their biological characters. Application of these methods to the study of intestinal bacteria in children has within the past five years brought to light information of great interest and value. It must be remembered, however, that this study is complex and extensive, but still in its infancy, and that further investigation may modify many of the views now held.

Bacteria in the feces of children living upon a mixed diet differ greatly in number and in kind from those in the healthy feces of milk-fed infants. The biological study of intestinal bacteria in children has been confined chiefly to the latter, to the bacteria in the meconium, and to those in the dejecta of infants affected with summer diarrhoea.

Bacteria were first observed in the feces in 1719 by Anthony van Leeuwenhoek,<sup>2</sup> a private citizen of Holland: they were found by him in the feces of various animals and in his own diarrhoeal feces. Leeuwenhoek

---

<sup>1</sup> As bacteriology has become a subject of so great importance to the physician and surgeon, and especially to those who see much of children's diseases, it has been fully treated of in vol. i., and thither the reader is referred for an account of methods for cultivating and studying the characteristics of bacteria.

<sup>2</sup> *Contemplationes Antonii de Leeuwenhoek, Opera Omnia*, tom. i., 1719, *Epistola ad Regiæ Societatis Collegium Londinense Robertum Hooke*.

attached no importance to these small organisms, but some of his contemporaries regarded them as a cause of a number of diseases. This opinion, unsupported by experimental evidence, was soon abandoned, and no further attention was given to the subject until about the middle of the present century.

In an article published in 1845, Gros<sup>1</sup> states that human excrements, whether healthy or diseased, swarm with vibrios of various sizes.

Frerichs,<sup>2</sup> in his celebrated article on digestion published in 1846 in Wagner's "Handwörterbuch," devoted a special section to the micro-organisms found in the alimentary canal, and described the morphology of the most striking forms seen by him. He regarded them as having little or no effect upon digestion, being harmless invaders which thrive and grow in the intestine because it affords a favorable soil.

Greater interest was given to the subject of intestinal bacteria, as of bacteria in general, by Pasteur's demonstration in 1857 that these organisms are capable of exciting profound chemical changes in the nature of fermentation and putrefaction, and the discovery by him and others that certain infectious diseases are caused by bacteria. Proceeding from the latter point of view, Hausmann,<sup>3</sup> Klebs,<sup>4</sup> Billroth,<sup>5</sup> Woodward,<sup>6</sup> and others directed their attention to a microscopical study of the bacteria found in the intestinal canal and the feces of healthy adults.

Woodward carefully described the morphology of the bacteria found in the normal and diarrhoeal feces. He recognized a difference in the size and quantity of the bacteria in the normal and the pathological feces, but, owing to their similarity, he was not able to establish a relation between individual forms of bacteria and definite diseases. He also recognized that similarity of form was not sufficient to prove an identity.

Hoppe-Seyler, Nencki, Fitz, Brefeld, Senator, and others undertook the investigation of the fermentative action of the intestinal bacteria, but, as their experiments were made with the mixed bacteria of the feces, without reference to their purity, no definite conclusions could be reached.

Both Pasteur and Duclaux,<sup>7</sup> although on insufficient data, expressed the opinion that great importance is to be attached to the rôle of micro-organisms in the work of digestion. Nothnagel<sup>8</sup> in 1881 was the first to attempt

<sup>1</sup> Observations et Indications microscopiques sur quelques Parasites, Extr. du Bulletin de la Soc. Imp. des Natur. de Moscou, t. xviii. p. 51.

<sup>2</sup> Article "Verdauung" in Wagner's Handwörterbuch der Physiologie, Bd. iii. S. 869, Braunschweig, 1846.

<sup>3</sup> Inaug. Diss., Berlin, 1870, Ueber parasitäre Vibriolen.

<sup>4</sup> Patholog. Anatomie, 1869, Bd. i. S. 271.

<sup>5</sup> Untersuchungen über die Vegetationsform von Coccobacteria septica, 1874, S. 94.

<sup>6</sup> The Medical and Surgical History of the War of the Rebellion, Part II. vol. i. pp. 278 et seq., 1879.

<sup>7</sup> Duclaux, Recherches sur la Digestion, Comptes-Rendus, 1882.

<sup>8</sup> Die normal in den menschlichen Darmentleerungen vorkommenden niedersten (pflanzlicher) Organismen, Zeitschr. f. Klin. Med., 1881, Bd. iii. S. 275.

to identify the various species of micro-organisms found in the fæces, according to their morphological peculiarities. He did not, however, isolate them by cultivation.

Brieger,<sup>1</sup> Bienstock,<sup>2</sup> and Stahl<sup>3</sup> were the first to take advantage of the modern methods for isolating bacteria and to attempt to establish the relation of the individual species of bacteria found in the fæces to definite fermentative processes. Brieger isolated from the normal fæces two species of bacteria possessing fermentative properties, one fermenting grape- and cane-sugar into ethyl alcohol, the other forming propionic acid out of grape-sugar.

Bienstock separated from the fæces a species of bacterium found in large quantity, which he considered to be capable of splitting albuminous compounds into their ultimate products. Besides this species Bienstock isolated three other bacilli, and arrived at the conclusion that these four species of bacilli are the only bacteria existing in the healthy intestinal canal with the administration of a mixed diet,—a conclusion in direct contradiction to that of all other observers.

Stahl, who was about the same time engaged in the systematic isolation of the bacteria of the adult fæces, found twenty different species of bacteria. This valuable work was, unfortunately, left incomplete by the death of its author, and no mention is made of the relation of these bacteria to fermentation.

Miller<sup>4</sup> isolated twenty-five varieties of bacteria from the mouth of adults, eight of which were again found in the stomach and twelve in the intestine. He also found that a considerable number of these varieties produce lactic-acid fermentation in carbohydrate solution, that a peptonizing action was shown by a majority, and that only a few varieties possess a diastatic action.

The preceding citations refer only to the investigations made upon adults.

Löschner and Lambl made the first special reference to the occurrence of vegetable parasites in the intestinal contents and fæces of children, in the report of the Franz-Joseph's Hospital in 1860. The report refers only to pathological cases.

Widerhofer<sup>5</sup> observed bacteria, especially leptothrix-like forms, frequently in the diarrhœal dejecta, and predicted that future investigation would bring one or other form into accidental or essential connection with

<sup>1</sup> Ueber Spaltungsproducte der Bacterien, Zeitschrift f. Physiolog. Chemie, Bde. viii. u. ix.

<sup>2</sup> Ueber die Bakterien der Fæces, vorläufige Mittheilung, Fortschritte der Medicin, 1883, u. Zeitschrift. f. Klin. Med., 1884, Bd. viii.

<sup>3</sup> Mikroorganismen in den Darmentleerungen, Verhandl. des III. Congresses f. innere Med., 1884.

<sup>4</sup> Ueber Gährvorgänge in Verdauungstractur und die dabei beteiligten Spaltpilze, Deutsche Med. Wochenschr., Dec. 3, 1885.

<sup>5</sup> Semiotik der Unterleiber, Jahrb. f. Kinderheilk., Bd. iv., A. F., 1871.

special intestinal diseases. Demme<sup>1</sup> repeatedly refers, in his reports of the Basel Children's Hospital, to the remarkable fact that even in the fæces of healthy children a large quantity of bacteria, especially rod forms, are found.

In spite of these statements, so little was generally known on the subject that Johnstone, even in 1881, drew the conclusion that the occurrence of bacteria in the stools of children affected with summer diarrhœa in the city of Leicester was due to an infection from the sewers, in which the bacteria were likewise found in great numbers.

Baginsky attempted, by means of a microscopical study of the diarrhœal dejecta and pathologico-anatomical examination, to establish the relation of bacteria to the etiology of summer diarrhœa in children. In his valuable work<sup>2</sup> he described the morphology of a number of bacteria and fungi: one form, a narrow bacillus, he found almost constantly in cholera infantum, and attached some importance to it. He became convinced, however, that no reliable information could be obtained by this method of research.

While these and many other investigations had been carried on with the diarrhœal fæces, the study of the bacteria in the normal fæces of children had been neglected to an astonishing degree.

Uffelmann<sup>3</sup> was the first to recognize this, and to realize that progress in the diagnosis and therapy of summer diarrhœa in children must be founded upon a chemical and microscopical study of the stools of healthy breast-fed children. (In 1842 Franz Simon made a chemical analysis of the fæces of healthy breast-fed children, and the subject was again taken up by Wegscheider in 1875, but neither made any reference to bacteria.) Uffelmann found the great mass of the fæces of healthy sucklings to be composed of micrococci and rod bacteria, the latter greatly predominating.

We owe to Escherich the fundamental investigation of the bacteria in the contents of the intestine and stools of healthy sucklings. His researches, made according to the most approved bacteriological methods, are of great value, and have laid the foundation for a fruitful study of the bacteria in the pathological stools of infants. Our information upon the bacteria in the meconium and healthy fæces of sucklings has been derived almost exclusively from his work.<sup>4</sup>

**The Entrance of Bacteria into the Intestine.**—The chief mode of ingress of bacteria to the intestine is through the air, the saliva, and the food which is swallowed, but, inasmuch as bacteria are sometimes found in the meconium taken from the rectum three to seven hours after birth, they may, no doubt, enter also per anum. To what extent the gastric juice pre-

<sup>1</sup> XVIII. Jahresbericht, S. 20.

<sup>2</sup> Verdauungskrankheiten der Kinder, Tübingen, 1884.

<sup>3</sup> Untersuchungen über der Verhalten der Fäces natürlich ernährten Säuglings, Deutsches Archiv f. Klin. Med., 1881, xxviii. S. 442.

<sup>4</sup> Die Darmbakterien des Säuglings und ihre Beziehungen zur Physiologie der Verdauung, Stuttgart, 1886.

vents the entrance of bacteria into the intestine is not definitely known. According to the investigations of Miller,<sup>1</sup> the gastric juice is not destructive to bacteria if the hydrochloric acid is in less proportion than 1.6 to 1000. Miller's observations led him to believe that the gastric juice does not hinder the greater portion of bacteria from entering the intestine, and that all the bacteria examined by him could pass through the stomach if swallowed at the beginning of the meal, but swallowed at the height of digestion the gastric juice was then more injurious. Busch observed in a case of intestinal fistula in a woman portions of the food in the intestine in from fifteen to twenty minutes after beginning the meal, and liquid and pulpy foods pass into the intestine sooner. Moreover, in pathological conditions of the stomach, when the gastric juice is not secreted normally and the hydrochloric acid is abnormally diminished, it may have little or no effect upon the bacteria. The development of bacteria in the intestine is dependent in large measure upon the nutritive media found in the intestine.

**Method for Collecting Intestinal Bacteria.**—Bacteria are collected from the healthy feces by causing an evacuation by the introduction of a sterilized glass rod or syringe-nozzle into the rectum, after having first washed the anus with sublimate solution and then with sterilized water. As soon as the feces are passed an opening is made on the surface of the mass with a heated knife, and a sterilized curved platinum needle introduced through the opening into the interior, from which small portions are taken up and put into sterilized test-tubes containing bouillon. Plate-cultures or Esmarch tubes are then made from the bouillon-cultures as soon as possible. From the contents of the intestine bacteria are similarly collected by cutting an opening in the wall of the intestine with heated scissors, through which the platinum needle is introduced. Bacteria are collected from the liquid diarrhoeal feces by introducing a small sterilized glass tube into the rectum, or, better, a larger sterilized tube first introduced through the anal opening and the smaller tube inserted through it into the rectum. In a short time a discharge from the bowels is produced, filling the inner tube, which is first withdrawn and emptied at once into the test-tube containing bouillon. The small tubes are conveniently kept ready for use in sterilized test-tubes.

**Meconium Bacteria.**—Escherich proved the correctness of the common belief that the meconium of the new-born infant is entirely free from micro-organisms. After a variable period bacteria make their appearance in the meconium, and usually by the second day after birth are present in large numbers. According to the observations made by Breslau<sup>2</sup> in 1866, the quick infection of the meconium takes place through the air which is swallowed, even before food is taken. Breslau observed that as soon as breathing begins the child makes sucking and swallowing movements, and

---

<sup>1</sup> Deutsche Med. Wochenschr., 1885, xii. 3.

<sup>2</sup> Zeitschr. f. Geburtskunde, 1866.

by means of percussion and a series of autopsies he found that air reaches the stomach and upper part of the duodenum in a few hours after birth. The air is carried through the intestine by peristalsis, and in twelve hours is perceptible over the greater part of the small intestine, and in twenty-four hours over the large intestine and the rectum. Escherich found bacteria in many cases in the meconium taken from the rectum from three to seven hours after birth, and believes that this can be accounted for only by the entrance of the bacteria per anum. As the meconium is infected from the germs in the surrounding air, it is evident that the varieties of bacteria and quickness of infection will depend upon the varieties and quantity of bacteria in the air. This is influenced by location, season of the year, and temperature. In the summer and in the city we may expect a richer vegetation in the meconium in twenty-four hours than in the winter and in the country. Tompkins found that the air in the diarrhoeal districts of the city of Leicester contained five times more bacteria than the air in districts not affected with diarrhoea. Not only is there a great difference in the time of appearance, but also in the varieties and quantity of bacteria in the meconium.

If the meconium is examined from three to seven hours after birth it is either sterile or contains only micrococci, mostly in the form of large diplococci. After eighteen hours, in most cases, rod-form bacteria are found. The micrococci are of relatively large size and great variety. The bacilli are also of manifold variety. Two spore-bearing species are especially noticeable, one of which belongs to the so-called head bacillus, consisting of a slender filament from four to seven micro-millimetres long, in which a glistening spore is set, the other appearing identical with the bacillus subtilis. Besides these forms are to be mentioned large circular or elliptical budding spores. As Escherich found in two such widely separated places as Munich and Vienna almost the same forms of bacteria in the meconium, especially the spore-bearing bacilli and micrococci, he thinks that, besides the accidental moment of air infection, a certain relation exists to the nutritive media in the meconium which affords a favorable condition for only certain kinds of bacteria. This he thinks is also shown in a negative sense by the disappearance of the rich and well-developed bacterial vegetation with the complete discharge of the meconium. Escherich had the opportunity of examining the last remnants of the meconium and the beginning of the milk faeces which were passed at the same time. In the first portion, which was shown by microscopical examination to be composed of the meconium almost exclusively, the head-form bacilli, a few short rods, and micrococci were found; while in the second portion, composed of milk faeces, no head-form bacteria or other forms belonging to the meconium were seen,—only the forms belonging to the milk faeces in sparse quantity.

This astonishing and easily-proved fact—*i.e.*, the change of bacterial vegetation with the beginning of milk nourishment—is of great importance to the knowledge of the conditions prevailing in intestinal putrefaction. It

seems to be the first direct proof of the dependence of the bacterial vegetation of the intestinal canal upon the chemical composition of the intestinal contents. The milk in the intestinal canal not containing all the ingredients necessary for the development of the meconium bacteria, they disappear and give place to other species. The disappearance of the meconium bacteria with the entrance of milk diet may be explained according to the observation of Nägeli, that the fermentation of bacteria is not merely advantageous to themselves but at the same time injurious to other species,—not through withdrawal of nourishment or secretion of injurious compounds, but through the presence of special fermentation.

Culture experiments distinguish two periods in the relation of bacteria to the meconium. The first meconium, as in the foetal condition, is still free from germs, or contains merely a few micrococci and germinating fungi which occur frequently in the surrounding air. These represent the microorganisms entering per anum. The second period is when the upper meconium column, early infected with germs from the air taken in per os, appears in the rectum. Here we find a tolerably rich and manifold variety. The difference between the bacterial vegetation of the meconium and that of the subsequent milk faeces consists in the meconium containing a smaller number of individual bacteria but a greater variety of forms, among which micrococci and certain spore-bearing bacilli are especially numerous.

**Intestinal Bacteria of the Healthy Suckling.**—A microscopical examination of the healthy faeces of sucklings shows it to be composed chiefly of bacteria, containing a larger number than the faeces of the adult and a much larger number than the meconium. This may be explained by the fact that the faeces of sucklings contain a larger proportion of water. A further comparison of the microscopical appearance of the healthy faeces of sucklings with the healthy faeces of adults gives the astonishing similarity of bacteria in the former in place of the manifold variety in the latter. While bacteria are present in enormous numbers in the faeces of healthy milk-fed infants, it was found that two species of bacteria are constantly present, and that of these one species so greatly predominates that it is sometimes found almost as a pure culture. The bacteria constantly present are the bacterium lactis aërogenes and the bacterium coli commune. These are designated obligatory milk-faeces bacteria, in distinction from the inconstant bacteria, which are called facultative or potential milk-faeces bacteria. The latter are found in small number and without regularity or frequency. Among them micrococci are generally but not always found, and only in small number. Long spore-bearing threads, free spores, spirals, and comma forms have not been observed.

In a systematic examination of the contents of the healthy gastro-intestinal canal of sucklings, it has been found that the stomach contains a very sparse vegetation composed chiefly of rod forms, the upper part of the duodenum a few round or short rod-like forms, but at the end of the upper third of the small intestine the vegetation becomes richer and con-



tains diplococci, bacteria lactis aërogenes, and colon bacteria. The latter increase in number and in the length of the individual bacteria in the lower part of the small intestine, but the bacteria lactis aërogenes undergo no further increase. In the cæcum there is a great increase of colon bacteria, and this continues throughout the colon, with an increase also in the length of the bacteria. The number of bacteria found in different sections of the intestine appears to depend upon the quantity of undigested food present and upon the length of time it remains there. The upper part of the duodenum, containing chiefly secretions and little or no food, is found, at least microscopically, to be almost free from bacteria. Here we have a large quantity of secretions free from bacteria, mixed with a small quantity of food containing them, which is removed by the active peristalsis of this part of the intestine before any considerable development of bacteria can take place. In the colon, where the food remains a longer time, the bacterial vegetation is correspondingly great. The increase in the length of the individual bacteria is ascribed to a preponderance of the older, well-grown forms or to the increasing exhaustion of the nutritive media (Buchner).

The inconstant or potential milk-fæces bacteria are found in larger number in the large intestine, and not at all, or only in small quantity, in the small intestine. There is found, then, not only a difference in the number and size of the bacteria in the upper and the lower part of the intestine, but also a difference in the variety of bacteria.

Our present bacteriological methods do not enable us to isolate in the form of pure cultures all of the bacteria existing in the fæces. There is, therefore, a discrepancy between the results of microscopical and those of bacteriological examination of the fæces, the latter method showing a smaller variety of organisms than the former. For this reason, if for no other, it is plain that the bacteriological cannot displace the microscopical examination. The two methods must be used in combination with each other. Efforts to obtain culture-media more suitable than those in common use for the cultivation of a large number of faecal bacteria have not been successful. According to the investigations of Buchner<sup>1</sup> and Kuisl, the vital energy of some of the bacteria is weakened through injurious influences acting upon them in the intestinal canal. All of the bacteria, however, are not thus affected. Buchner believes that the normal intestinal ferments act injuriously upon bacteria. But it has been shown that none of the normal secretions of the digestive tract except the acid gastric juice have an injurious effect upon bacteria. It is more probable that many of the varieties of bacteria which enter the intestine fail to find suitable conditions for their development.

The antagonistic action which is known to exist between many different varieties of bacteria when planted together may also assist in clearing up the discrepancy between the number and kind of organisms found microscopically and by the culture methods.

---

<sup>1</sup> Archiv f. Hygiene, 1885, S. 399.

**Biological Characters of the Obligatory Milk-Fæces Bacteria.**—*Bacterium Lactis Aërogenes.*—*Morphology.*—Short thick rods with rounded ends, often joined in pairs. Average size from one to two micro-millimetres long and one-half to one micro-millimetre wide. The short forms sometimes appear oval or almost round. In cultures eight days old the bacilli are longer than in fresh cultures, and many show when stained with gentian violet a deep violet centre with purple or clear poles. The bacilli show no motion of their own, and have not been found to contain spores.

*Bacterium lactis aërogenes* grows readily on the ordinary culture-media. In gelatin cultures the colonies develop rapidly, grow more in height, and do not spread extensively over the surface. They are generally round, with even borders, though often irregular in shape, white to the naked eye, and seen under the microscope have a yellow or yellowish-brown appearance. In stab cultures the surface growth is white, raised, and extends uniformly a short distance from the point of inoculation. Along the line of inoculation in the depth is a solid stalk, with sometimes a marked swelling at the end. Some stick cultures show the nail-form growth. On potato the culture is whitish yellow or cream-colored, thick, of pulpy consistency, and has numerous gas-bubbles over the surface. It coagulates milk with acid reaction and with evolution of gas. *Bacterium lactis aërogenes* resembles the lactic-acid bacillus of Happe and in many respects the pneumococcus, but is not identical with either.

*Pathogenic Properties.*—*Bacterium lactis aërogenes* has no effect when injected subcutaneously into mice. Injected into the blood of guinea-pigs death resulted in twenty-four hours, with symptoms of collapse, and revealing in autopsies the phenomena of intestinal catarrh. Similar effect was produced by the subcutaneous injection of a large quantity, but no effect from a small quantity. The same results are observed in rabbits, save that the action is slower and generally accompanied by diarrhœa. The rapidity of the pathological effects points to a toxic rather than a direct action upon the walls of the intestine.

*Bacterium Coli Commune.*—This appears to be one of the most widely distributed of all known bacteria. It is found in the meconium, in the feces of milk, flesh, mixed diet, and in diarrhœa, and appears to be seldom, if ever, entirely absent from the feces. *Bacterium coli commune* is considered by Weisner identical with the Naples bacillus of Emmerich. Sternberg<sup>1</sup> found it constantly and as the predominating form in the intestine and often in the stomach in yellow-fever cases.

*Bacterium coli commune* is characterized not only by its wide distribution, but also by the great variation in the character of its growth and morphology. The latter varies in different stages of growth and in different media. The smaller forms show very little difference in length and

---

<sup>1</sup> Further Researches in the Etiology of Yellow Fever, Trans. Assoc. Amer. Phys., 1888.

breadth, which is about one-half micro-millimetre, while in gelatin cultures some forms reach five micro-millimetres or more in length: all grades between these are seen. In the fæces they are often observed with uncolored places in the length of the rod, giving a pretty spotted appearance. The morphology, which is so variable in the fæces of different children as to require the culture test to recognize it as the same bacillus, is more uniform in the fæces of the same child, and especially in the same stool. This difference is probably due to the slight nutritive alterations in the intestinal contents of different children and in the same child at different times.

*Bacterium coli commune* grows readily upon the ordinary culture-media. On gelatin the colonies are so variable that no characteristic description can be given: they generally spread extensively over the surface and have a bluish-white appearance to the naked eye. Slightly magnified, they are at first white, with fine markings, but as they grow older are brownish or straw-colored. Sternberg has recently found that when twenty-per-cent. gelatin cultures are kept at a certain temperature offshoots appear on the sides of the stalk in the depth of the gelatin. Cultures from the offshoots and from the main stem between them gave different results, the cultures from the offshoots resembling Emmerich's Naples bacillus, those from the main stem the *bacterium coli commune*. Further cultivation from these low apparently different varieties again gave similar culture-results, which led Sternberg to regard Emmerich's bacillus as a sport of the *bacterium coli commune*. If this result is confirmed by thorough tests it will explain many of the difficulties experienced by all who have attempted to study the colon bacteria. On potato cultures the *bacterium coli commune* is more uniform, having a brownish-yellow color, with sometimes a glistening surface. It coagulates milk more slowly than the *bacterium lactis aërogenes*, requiring from six to eight days at from 30° to 35° C. The pathogenic properties are similar to those of the *bacterium lactis aërogenes*.

**Relation of the Intestinal Bacteria to the Fermentative Processes in the Intestines of Sucklings.**—The growth and development of bacteria in the intestinal canal, which contains no free oxygen, or only a slight and insufficient quantity, is dependent upon the presence of some fermentative substance which is decomposed by the activity of the bacteria. Free oxygen, being necessary to the life of all bacteria, can be supplied in the presence of active fermentation (Naegeli). Escherich proved experimentally that milk-sugar supplied the fermentative substance in the healthy intestine of sucklings, it being the only ingredient of milk decomposed by the bacteria found in the normal intestine of sucklings on the exclusion of oxygen, casein and fats being not at all or only slightly acted upon. Of the bacteria found in the normal intestine of sucklings the *bacterium lactis aërogenes* is the only species which causes fermentation in milk without oxygen, producing a fermentation of milk-sugar with the formation of lactic acid and the development of carbonic acid and hydrogen. According

to more recent experiments by Baginsky,<sup>1</sup> it is an acetic-acid and not a lactic-acid fermentation. Baginsky found that the bacterium *lactis aërogenes* ferments milk-sugar, with the formation of only a minimum quantity of lactic acid and with simultaneous entrance of acetone; that the greater quantity of formed acid is acetic acid; that the fermentation proceeds as well without as with oxygen and is not hindered by the presence of bile-ingredients. The gases accompanying the acetic-acid fermentation are carbonic acid, methane, and hydrogen. There is every reason to believe that it is the bacterium *lactis aërogenes* which causes this species of fermentation, proved to occur normally in the infant's intestine, and that the intestinal gases carbonic acid, methane, and hydrogen are derived from this fermentation.

*Bacterium lactis aërogenes* has not been found in the meconium, nor in the intestine or faeces after a flesh diet, but it is always found in the intestine after a milk diet. Its vital activity in the intestine appears to depend upon the presence of milk-sugar, and its extension there corresponds with that of this substance. Milk-sugar is completely absorbed in the stomach and small intestine, and is not found normally in the large intestine. At the time of milk digestion the bacterium *lactis aërogenes* is found in great quantity in the upper part of the small intestine, and in proportion to the absorption of milk-sugar it becomes scarce, diminishing in number throughout the colon, and in the faeces comparatively few individuals of this species are found.

On the other hand, the bacterium *coli commune* is found but sparsely in the upper part of the intestine, becomes more and more numerous towards the end of the intestine, and vastly exceeds in number all other species of bacteria in the faeces, being also found in the faeces after a flesh or mixed diet and in the meconium before any food is swallowed. As sugar and casein are absorbed before reaching the large intestine, and the fats but slightly broken up into glycerin and fatty acids, the former being readily absorbed, it seems that no ingredient of milk is of influence in the development of the colon bacterium in the intestinal canal, but rather that some fermentative substance contained in the intestinal secretions is the cause. According to Landwehr,<sup>2</sup> almost the whole of the mucus in the intestine is decomposed, and it is probable that the bacterium *coli commune* causes some species of fermentation or decomposition of the mucus.

There appear, then, to be two fermentative processes taking place in the intestine after an exclusive milk diet, which are separated both locally and at the time of occurrence. In the upper part of the intestine is a decomposition of milk-sugar by the bacterium *lactis aërogenes*, and in the lower part a fermentation of the intestinal secretion by the bacterium *coli commune*. The saccharine fermentation commences with the entrance of

<sup>1</sup> Ueber Gährvorgänge im kindlichen Darmcanal u. die Gährungstherapie der Verdauungskrankheiten, Deutsche Med. Wochenschr., 1888.

<sup>2</sup> Zeitschr. f. Physiolog. Chemie, 1885, Bd. ix.

the milk ingredients into the duodenum, and, as the absorption of milk-sugar is rapid, it continues but a short time after gastric digestion is completed. The zone of this fermentation is confined to the upper part of the small intestine, and extends with decreasing intensity, according to the stage of digestion and the activity of absorption, more or less down the intestine, without at any time passing the ileo-cæcal valve. The other fermentation begins with the conclusion of the first, and continues until the fecal mass is thrown off. This slower fermentation of the bacterium coli commune is limited mostly to the large intestine.

**Participation of Bacteria in the Normal Digestion of Sucklings.**—The question as to the extent to which bacteria affect digestion, and whether favorably or injuriously, has not yet received the attention that its importance deserves. Some text-books on physiology ascribe to bacteria an important rôle, and consider normal digestion without them impossible; others look upon them as having no physiological importance. In milk digestion, casein, the most important ingredient, appears, according to the experiments of Tiedman and Gmelin, to be completely dissolved and chiefly absorbed in the stomach. Frerichs gives a similar opinion. In puppies and kittens he did not see in a single case undissolved casein below the pylorus.

Among later authors, Reichmann<sup>1</sup> observed a complete change of the originally coagulated casein into the soluble form in the stomach; but it is doubtful if the same occurs in the suckling, where the anatomical nature of the stomach indicates that the food remains but a short time and the gastric juice is less abundant than in the adult. If we consider the action of bacteria upon the ingredients of milk, we find that the albuminous bacillus of Bienstock has no action upon casein and alkali albumen. Of the intestinal bacteria of the healthy suckling, two of the inconstant varieties, bacillus subtilis and streptococcus coli gracilis, decompose casein, but only in the presence of free oxygen. The other varieties have no action upon casein.

An important question has been raised by Uffelmann,—*i.e.*, Are the proteids absorbed or used for the development of bacteria? The number of bacteria in the upper part of the intestine is less than in the lower, and they increase rapidly below the ileo-cæcal valve. Casein and sugar, on the contrary, are continually decreasing through absorption, and do not reach the large intestine, the chief seat of bacterial development. The two constant varieties of bacteria have but slight need of nitrogen, and this is probably derived from the serum albumen for the bacterium lactis aërogenes, and from the secretions of the colon for the bacterium coli commune. The small number of the bacteria in the small intestine indicates but slight need of nitrogen there. It seems probable, as Wegscheider suggests, that the casein of human milk is completely absorbed.

The quick absorption of casein, and the want of albuminous decomposition generally in the intestinal canal of sucklings, which does not appear

<sup>1</sup> Zeitschr. f. Klin. Med., 1885.

possible in the lack of proteolytic activity of the milk-fæces bacteria, afford the best explanation for the absence of products of albuminous decomposition and of the fæcal odor from the fæces of sucklings.

**Potential or Inconstant Milk-Fæces Bacteria.**—Under this head are embraced all those bacteria which do not possess a fermentative action upon any of the materials in the contents of the normal intestine of the sucklings. They are found only in small number, inconstantly, and without perceptible relation to the chemical composition of the nourishment in the normal fæces. They are for the most part aerobic, and, so far as they develop at all in the intestinal canal, probably grow on the peripheral layer, which contains a small amount of oxygen. Corresponding to the greater extension of this layer in the large intestine, they are found there more frequently and in larger quantity, while in the small intestine they appear to be almost completely absent. In sucklings who have suffered from digestive disturbance and whose stools have again become normal, they are found in larger quantity. The inconstant bacteria are, as a rule, somewhat more numerous in the fæces of infants fed with cow's milk than in the stools of sucklings.

Escherich isolated twelve varieties of inconstant milk-fæces bacteria, of which the micrococci were as numerous as the bacilli, and the varieties that liquefy gelatin as numerous as the non-liquefying varieties.

Two facts of the greatest importance are brought to light by Escherich's investigations,—viz., the remarkable and unexpected simplicity and uniformity of the bacterial vegetation in the healthy fæces of milk-fed infants, and the variation in this vegetation which occurs with a change in the quality of the diet.

At first glance it is not easy to understand why, of the manifold varieties of bacteria that gain access to the infant's intestine, only two should develop there constantly and in large number; but this difficulty is lessened when we consider that an organism in order to supply itself with the necessary oxygen and food in the intestine must be capable of causing anaerobic fermentation in the intestinal contents. In harmony with the simple and uniform food of milk-fed infants, we find a corresponding uniformity in their intestinal bacteria.

It is not possible to foresee to what clinical and therapeutic uses the knowledge of the constant characters of the bacterial vegetation in the normal milk fæces may be put. It seems a justifiable inference that any marked variation in the quality of this bacterial vegetation is an expression of some disturbance in the alimentary canal.

**Bacteria found in the Dejecta of Infants affected with Summer Diarrhœa.**—As long as the normal fæces were believed to contain a chaotic mass of all sorts of bacteria, it seemed a useless and unpromising task to make an especial study of the likewise chaotic mass of bacteria in the diarrhœal stools. This point of view, however, is now changed. With definite information concerning the more important and constant bacterial species in

the normal stools, it has become a matter of the utmost interest to learn what new species of bacteria appear in diarrhoeal stools and what changes occur in the normal bacterial vegetation.

Such knowledge may prove valuable in many ways. Hitherto the study of the faecal bacteria in pathological cases has had especially for its object the discovery of some specific forms which might be regarded as the essential cause of disease. This is, of course, a most important object of research.

There is also another point of view hardly less important, which is based upon the fact that the kinds of bacteria found in the faeces vary with the intestinal contents which serve as food for the bacteria. Thus, we find a sharply-defined difference in the bacterial vegetations characterizing milk faeces, meconium, meat faeces, faeces from a mixed diet, etc. In cases of summer diarrhoea there are abnormal changes in the contents of the stomach and of the intestine, in consequence of morbid secretions, peristalsis, and fermentations, and corresponding to these abnormal intestinal contents we may expect to find abnormal vegetations of bacteria, and it is reasonable to suppose that some definite relations may be discovered between certain forms of bacteria and certain definite changes in the intestinal contents. Such a discovery might be of diagnostic and perhaps even of therapeutic value.

It is evident that great caution must be used in assuming that any causal relation exists between strange forms of bacteria in the faeces and the existing disease. Various interpretations of such a coincidence are possible. First, it may be that the new forms of bacteria are to be regarded simply as the necessary accompaniment of the altered intestinal contents, not influencing in any way the disease. Even upon this supposition of their harmless saprophytic nature the study of these bacteria may prove of diagnostic and therapeutic value. In the second place, the new forms of bacteria, while not the primary cause of disease, may by their presence and growth in the intestine cause a continuance and aggravation of the disease. For instance, we can readily suppose that a gastric or intestinal catarrh, or some abnormality in peristalsis or secretion, induced primarily by error in diet, or by heat, or by some constitutional cause, or by unhygienic surroundings, may be kept up and aggravated by the presence of micro-organisms, whose continued existence in the intestine is first rendered possible by some abnormality which would be otherwise transitory. In the third place, the bacteria may begin their work outside of the body, by developing in the milk or other food taken by the infant, and causing abnormal products of fermentation or decomposition, possibly poisonous ptomaines. In the fourth place, one or more of the species of bacteria found in the stools of infants affected with summer diarrhoea, and not found in the normal stools, may be the essential and specific cause of the disease, in the same sense that the typhoid bacillus causes typhoid fever or the anthrax bacillus causes anthrax. It must be admitted that without

further proof of any given case the presumption is against this last supposition.

In view of the very peculiar qualities which bacteria must possess in order to adapt themselves to the conditions of growth in the healthy infant's intestine, and the preoccupation of the field by other bacteria, it is not likely that bacteria which enter the normal intestine will be able to displace those normally existing there. That preparation of the soil which we vaguely call predisposition doubtless plays a most important rôle in the summer diarrhœa of children. Given a favorable soil, such as that resulting from gastric or intestinal catarrh, or from abnormalities in peristalsis or secretion, bacteria which would fail to gain lodgement in the healthy intestine may grow and by their presence become the most serious factor in the disease.

The only way to attack, with any hope of success, the problem as to the significance of micro-organisms in the diarrhœal stools of children, is to isolate, as far as possible, the various species, according to the modern bacteriological methods, which we owe to Koch. The organisms thus isolated must be studied morphologically and biologically, more especially with reference to their fermentative and pathogenic properties, and, as the different varieties of bacteria may affect the activity of one another, it will be necessary to observe their action when different varieties are mixed. Furthermore, such organisms must be compared with those found in the healthy stools, and the frequency of their presence in diarrhœal stools, and their relation to different varieties of the summer diarrhœa of children, must, if possible, be established.

Our knowledge of the bacteria in the diarrhœal feces is not so advanced as that in regard to the healthy milk-fœces bacteria, and in the following account of what has been accomplished in this direction it is only intended to give the present state of our information upon the subject, which is by no means sufficiently matured to admit of positive conclusions.

Hayem and Lesage<sup>1</sup> attach great importance to a bacillus which they have separated from the intestinal contents and stools of infants affected with "green diarrhœa." They distinguish two forms of green diarrhœa, the bilious and the infectious. In the former the green color is dependent upon a redundant secretion of bile and upon the presence of an abnormal quantity of bile-coloring matter in the stools. This form appears ordinarily between the fourth and the twenty-fifth day, and is without other phenomena of disease.

The infectious form is essentially different, the stools containing only a small quantity of bile-ingredients and having a neutral or an acid reaction. The green color of the stools in this form is dependent upon the presence of coloring-matter which is produced by the bacillus which is found in the intestinal canal and stools of children affected with this form of diarrhœa.

---

<sup>1</sup> Lesage, De la Diarrhée verte des Enfants du premier Age, Bulletin Médical, 1887, xxvi. 10.



The bacillus is a narrow rod, with rounded ends, from two to three micro-millimetres long and one micro-millimetre wide; in old cultures or under conditions unfavorable to its development it grows in long threads (twenty micro-millimetres). It grows by division and spore-formation, and does not liquefy gelatin. This bacillus is especially found in the upper two-thirds of the small intestine, more sparsely and in long threads in the large intestine and stools.

The most conspicuous property of the bacillus is the power to produce a green coloring-matter which is soluble in water, and which increases to a still darker green when exposed to air. The coloring-matter is produced in cultures on the different nutritive media. In animal experiments with this bacillus hypodermic injections gave negative results. Injected into the blood the bacillus appeared in the duodenum in from ten to twelve hours, and caused, by its increase in the intestine, the green diarrhœa. Similar results followed the injection of the bacillus directly into the intestine, or when it was introduced through the food into the stomach. The experiments were successful only with suckling animals. The bacillus is not found in water or milk, but spreads through the air from drying diapers. The epidemics of diarrhœa in St. Anthony's Hospital date, each time, with the entrance of a patient affected with green diarrhœa, independent of the time of year, and attacked both breast-fed and artificially-fed children.

Baginsky<sup>1</sup> has separated from the dejecta of infants affected with "acid diarrhœa" two varieties of bacteria which liquefy gelatin, one of which produces a green coloring-matter, and he considers this identical with the bacillus described by Hayem and Lesage. As the latter does not liquefy gelatin, it should be regarded as a different variety. The other bacterium described by Baginsky is non-chromogenic, and was found constantly in the diarrhœal stools. This variety is quickly fatal to animals, and Baginsky thinks it probably plays an important rôle in the pathogenesis of diarrhœa.

If this bacillus and the bacterium *lactis aërogenes*, the constant bacterium of the healthy small intestine of sucklings, are introduced at the same time into gelatin supplied with milk-sugar, the bacterium *lactis aërogenes* shows an active development, with evolution of gas, while the white liquefying bacillus ordinarily does not develop and but exceptionally causes a liquefaction in the gelatin. This led Baginsky to the opinion that the bacterium *lactis aërogenes* placed under favorable conditions may prevent the growth of pathogenic organisms, and that in the acetic-acid fermentation of milk-sugar caused by the bacterium *lactis aërogenes* we have a remedy which serves in the infant's organism to protect the intestinal wall from pathogenic bacteria. But when this fermentation exceeds a certain degree, which may happen in abnormal conditions of the intestine, it destroys the bacterium *lactis aërogenes* and thus lays the foundation for pathological processes of various kinds.

---

<sup>1</sup> Deutsche Med. Wochenschrift, 1888.

In a systematic isolation and study of the biological characters of the bacteria found in the dejecta of infants affected with summer diarrhoea, carried on in the pathological laboratory of the Johns Hopkins University,<sup>1</sup> I have isolated forty varieties of bacteria from the dejecta of thirty infants, eleven of whom had cholera infantum, fourteen catarrhal enteritis, and five dysentery. These children were all seriously sick, especially the cases of cholera infantum and dysentery.

The bacteria found in these cases presented many points of difference from the bacteria in the healthy milk faeces of infants. Not only was a greater variety of bacteria found in individual cases, but most of the cases contained one or more varieties not found in others.

This great variation of the bacterial vegetation in the diarrhoeal faeces affords some estimate of the time and labor required for a proper understanding of them, and still more of the great importance of avoiding hasty conclusions in regard to their significance. It seems an endless task to isolate and study all the varieties of bacteria contained in the diarrhoeal faeces that can be cultivated even with our present nutritive media.

The greatest number of varieties of bacteria were found in the cases of cholera infantum; a larger number in catarrhal enteritis than in dysentery; and the smallest number in the healthy child used for control, only one variety being found there; but the actual number of individual bacteria in the healthy milk faeces is as great as in that of the diarrhoeal faeces.

Eight varieties of bacteria, the largest number isolated in any single case, were found in each of four cases.

The difference in the number of varieties of bacteria found in the faeces does not necessarily indicate a similar difference in the intestinal canal. In the diarrhoeal faeces which come from the upper as well as the lower intestine and are discharged at such short intervals that no considerable delay can occur in any part of the canal, the conditions are more favorable for obtaining representations from all portions of the canal than is the case in the dysenteric discharges, which come chiefly from the lower intestine, and in the healthy faeces, which are voided once in twenty-four hours and are probably retained in the colon sufficiently long to cause the death of many bacteria which cannot exist for a long time in the large intestine.

Nor is it claimed that the cultures obtained represent absolutely all the varieties of bacteria contained in the faeces, as the bacteria may not be equally distributed through the faeces, and their colony growth, especially upon agar, to which we are limited in this climate during the greater portion of the summer for plate-cultures, is not always distinctive enough to be recognized. Moreover, not all the bacteria present in the faeces will grow in our ordinary culture-media.

The bacteria in the diarrhoeal faeces differ from the inconstant varieties

---

<sup>1</sup> A Study of some of the Bacteria found in the Dejecta of Infants affected with Summer Diarrhoea, Trans. Ninth International Med. Congress, vol. iii., 1887.

found by Escherich in the healthy milk faeces. In the latter varieties of micrococci are as numerous as those of bacilli, and the liquefying as numerous as the non-liquefying varieties. Chromogenic bacteria also occur frequently. Of the forty varieties of bacteria isolated from the diarrhoeal faeces only one was a micrococcus, seven were liquefying, and none were chromogenic bacteria. Culture test failed to identify any variety with the inconstant bacteria found by Escherich.

The constant or obligatory bacteria of the healthy milk faeces do not disappear in the diarrhoeal faeces.

The bacterium *coli commune*, or varieties of the colon group of bacteria, were found in all cases of diarrhoea, but not in the largely predominating form as is the case in the healthy milk faeces, and appeared to diminish in number according to the severity of the disease. They were not found in the dysenteric discharges.

The bacterium *lactis aërogenes* appears more frequently and in larger number in the diarrhoeal than in the healthy milk faeces, and was found in most but not in all of the cases.

No variety of bacteria has been found which bears the relation of constant or obligatory bacterium to the diarrhoeal and dysenteric discharges which the colon bacterium bears to the healthy milk faeces. Many of the varieties of bacteria were found only once, while others were discovered in two or more cases, but no variety was found in a sufficiently large number of cases to be of importance from that fact alone.

Bacteria belonging to the proteus group were the most frequent, and were limited to the more serious cases of cholera infantum. Varieties of this group were found in seven of the eleven cases of cholera infantum, proteus vulgaris in three cases, and a variety, which I have designated bacillus A, in four cases.

Bacillus A produces the swimming colonies in gelatin, but differs from proteus vulgaris in coagulating milk with alkaline reaction, in the growth on potato, and in having a nearly uniform morphology. It is a narrow bacillus, with rounded ends, varying in length, but with an average size in fresh cultures of three micro-millimetres long and seven-tenths of a micro-millimetre wide. The bacillus is motile, liquefies gelatin, and renders slightly-acid milk alkaline, producing a gelatinous coagulation with alkaline reaction. It grows readily in agar; in stab cultures the surface is covered in a few days with a nearly colorless scum, and in the depth is a delicate and luxuriant stalk corresponding with the line of insertion of the platinum needle. Agar colonies are round and bluish white and often diffused through the agar; slightly magnified, the colonies are light brown, with indistinct borders.

The presence of members of the proteus group of bacteria in a large proportion of the most serious cases having symptoms of cholera infantum, as collapse, stupor, vomiting, and frequent watery and offensive stools, is not without significance.

Escherich found the proteus vulgaris in the meconium, but he did not find any of this group in the healthy milk fæces. In the healthy suckling the albuminous ingredients of milk are probably soon absorbed and remain but a short time in the intestine.

According to Hauser, the proteus group of bacteria do not grow in the so-called normal solution, and seem to require highly-organized, especially albuminous, compounds. They excite putrefaction in animal tissues, with the development of a serious poison and evolution of stinking gas, and, on account of their wide distribution and frequent occurrence, belong to the most important and common putrefaction-exciter.

Pathogenic properties, as manifested in experiments upon the lower animals, appeared very marked in this group of bacteria. Milk cultures of bacillus A fed to mice and guinea-pigs resulted fatally in every case, death occurring in from one to eight days. Autopsies revealed nothing abnormal except a certain degree of emaciation. The bacillus was found by the culture-test in the stomach and intestine of all the animals, and, as a rule, in greater number in the small than in the large intestine. It was also found in some cases in other organs, especially the kidney. In all the animals to which the milk cultures were fed more or less stupor was produced.

Bouillon cultures of bacillus A eighteen days old, when sterilized by the interrupted method, and injected in small quantity (one-half cubic centimetre) into the jugular vein of rats, resulted in death in from two and a half to five hours. A small quantity of an eight-days' agar culture put into one cubic centimetre of sterilized water and one-half of this injected into the jugular vein of rats was without results. From this it appears that the pathogenic properties of bacillus A reside in its power of producing injurious products in albuminous compounds.

Diarrhœa was not a prominent symptom in the animals in which experiments were made, a pronounced diarrhœa being observed in only one case.

Bouillon or liquefied gelatin cultures, two weeks old, of a bacillus apparently identical with proteus vulgaris, injected into the ear-vein of rabbits, resulted in death in from two to twenty hours. Active diarrhœa occurred a few hours after the injection in a number of the rabbits, but not in all of them. Drowsiness and accelerated breathing were prominent symptoms in all cases, and in some the drowsiness was preceded by restlessness. Similar cultures injected into the intestine after the abdomen had been opened in a bath of normal salt solution at 38° C., Sanders-Ezn's method, caused active rhythmic and peristaltic contractions.

Another bacillus having marked pathogenic properties in lower animals was found in four very serious cases of cholera infantum. It is a small bacillus, with rounded ends, from one to two micro-millimetres long and one-half micro-millimetre wide, and liquefies gelatin rapidly. Stab cultures are liquefied along the line of insertion of the platinum needle, trumpet shape; the liquefied colonies are uniformly granular. It grows luxuriantly on potato with a light-yellow color when fresh and a slight

pink tint as the culture grows older. Bouillon cultures of this bacillus injected into the ear-vein of rabbits resulted in death, and injected into the intestine by Sanders-Ezn's method caused rhythmic and peristaltic contractions.

The other varieties of bacteria with which experiments were made on lower animals did not show any decided pathogenic properties.

The bacteria isolated from the diarrhœal fœces do not multiply in ordinary hydrant-water, and retain an active developmental condition but a short time after being placed in it. Water inoculated with the different varieties failed to give cultures in any case after forty-eight hours, and in a great number of cases after twenty-four hours.

All the varieties thrive and many produce important changes in milk. Some cause coagulation with acid reaction, some render it acid without coagulation, some alkaline without coagulation, and others change slightly-acid milk into alkaline and then coagulate it with alkaline reaction. Some cause milk to become a transparent fluid without coagulating it, while others produce this change after first coagulating the milk. Seven varieties in addition to the bacillus lactis aërogenes produce active fermentation in milk, but the nature of the fermentation has not yet been ascertained.

Milk undergoes a considerable change in microscopical appearance in a short time when inoculated with certain varieties of bacteria, while with others no change is perceptible for weeks.

Fresh milk examined under the microscope shows only oil-globules floating in a colorless fluid. When sterilized, kept for weeks, and then examined, no difference is observed beyond a greater tendency of the oil-globules to run together, and in very old specimens a few crystals or fatty acids.

Fresh sterilized milk inoculated with bacterium lactis aërogenes and kept in the thermostat forty-eight hours shows under the microscope a considerable quantity of fine granular matter of yellowish-brown appearance, and at the same time a diminution in the quantity of oil-globules: four to six days later little is to be seen but this granular matter and the bacteria, only a few oil-globules being present. If a small quantity of bile is added to the milk no difference is observed from the pure milk cultures, but the addition of a large quantity of bile requires a longer time for the disappearance of oil-globules and the deposit of granular matter. This granular matter, probably the casein of milk, is dissolved by caustic potash, and is not colored black with osmic acid. Several other varieties have a similar effect upon the microscopical appearance of milk, and in one variety the changes appear to be hastened by the addition of bile. With other varieties little if any difference is observed even after a considerable time has elapsed.

Bile is not destructive to the bacteria found in the diarrhœal fœces. Most of the varieties of bacteria isolated were introduced into pure bile taken with aseptic precautions from the gall-bladders of freshly-killed

dogs, and from this cultures of each variety were obtained after the bile had remained several days in the thermostat.

The yellow color given to milk when bile is added is affected differently by the different varieties of bacteria. *Bacterium lactis aërogenes* gives a bright yellow color to the mixture. Some varieties reduce the bile coloring, giving a whitish-gray or white color to the mixture. Some give a brown color, and others show no difference from the control.

As far as the biological characters of the bacteria in the diarrhoeal stools of infants have been studied, it appears that not one specific kind but many different kinds of bacteria are concerned, and their action is manifested more in the alteration of the food and intestinal contents, and in the production of injurious products, than in a direct irritation upon the intestinal wall.

# ACUTE AND CHRONIC CONSTIPATION.

BY CHARLES WARRINGTON EARLE, M.D.

---

**Definition.**—A delayed expulsion of faecal matter, a retention of intestinal excrementitious substances beyond the normal period, infrequent or incomplete alvine discharges, or a scarcity or complete absence of faecal evacuations. Constipation is only a relative term, and, according to some authorities, should not be confounded with costiveness, which is merely scanty faeces. It is frequently a part of the phenomena of disease, and while in many cases it produces pathological lesions, in other cases it even does not give rise to any morbid conditions, but is present in those who enjoy a comfortable degree of health. It has been suggested that those having a tendency to constipation are more apt to contract, from accidental or slight causes, a habit which is attended with pathological results.

Constipation, then, is not so much a disease in itself as it is a symptom of various morbid conditions. It is, therefore, exceedingly difficult to define this condition in children; for oftentimes it is merely a trivial affair, while at other times it not only is serious, profoundly affecting the patient at once, and remotely other organs and the general nutrition of the entire body, but jeopardizes life itself.

**History.**—The inconveniences and danger of the constipated habit were recognized by the early authors. Hippocrates pointed out many of the pathological results produced by the difficulty we are considering, and as means of relief suggested laxatives, injections, and suppositories. Celsus and others also mentioned the subject. Very little, however, has thus far been written regarding the constipation of children. In some of the most exhaustive works on pediatrics published ten and twenty years ago, hardly a paragraph is devoted to the subject. This is true respecting the works of our eminent countrymen Prof. J. Lewis Smith and Drs. Meigs and Pepper, although in Prof. Smith's last edition, 1886, we find probably the most valuable article on the subject in the English language. It is true also concerning the great work "Maladies des Enfants," by the French authorities Barthez and Rilliet (ed. 1861), and even in German literature on sick children the subject is hardly mentioned. In Gerhardt's Handbook we do find an article of eleven pages by Widerhofer, but in the *Archiv für Kinder-*

*heilkunde*, the publication of which was commenced in 1880, not a single complete article has appeared.

There are certain anatomical, physiological, and dietetic reasons for constipation in children that do not exist in the adult.

**Anatomy.**—The small intestine is relatively longer and its calibre smaller in the child than in the adult. The walls are also thinner and weaker. The ascending and the transverse colon are shorter compared with the adult, and the descending portion is longer. A larger number of curves and, possibly, angles are formed, because of pressure from above by the liver, which is larger in the child, and of the contracted condition of the pelvis, which is well known to be smaller than in the adult. These anatomical peculiarities give less space to the intestinal tract, and in some cases really represent an etiological factor in causing constipation. The peristaltic movements in babies are slight, because of the imperfectly-developed muscular structure. As a child develops, both peristaltic and muscular tones are increased. Another anatomical peculiarity in children is the deep cul-de-sac which the sigmoid flexure forms before it enters the rectum. This peculiarity predisposes to fecal accumulations. One authority, Gerhardt, says, however, that the sigmoid flexure does not make the deep and great anterior and backward curves which have been represented by some authors.

According to Jacobi, the length of the intestinal tract in children, with its tendency to overlap and elongate, is a cause not only of constipation, but also of the more serious surgical difficulties, such as intussusception, etc. Treves has recently pointed out the anatomical changes in the colon that almost always attend chronic constipation.

**Physiology.**—In a healthy child the mother's milk is mostly absorbed and assimilated, leaving but a small residue, and the amount of material evacuated has some relation to the amount taken into the system. The albumen of milk is nearly all digested in the stomach and bowels of the child, and from this very process we have a physiological cause of constipation in children,—fecal matter existing in such small amount that intestinal peristalsis is not excited. In older children and adults, if constipation has not become habitual, the rectum is usually empty. When defecation is regular, the faecal mass descends into the rectum and produces the uneasy sensations which precede a healthy evacuation. If this call is not heeded, a reverse peristalsis is excited in the walls of the rectum, and the faecal matter is returned to the sigmoid flexure. If this neglect becomes habitual, the return to the upper bowel does not take place, and an accumulation follows, with all its attendant evils to pelvic circulation.

In infants, on account of the pasty condition of the intestinal matter, it seems normal for the rectum to contain more or less excrementitious material, which explains in some degree the number of daily evacuations from the bowels which must be regarded as natural in the infant or child.

What, then, constitutes constipation in an infant? This is a difficult



question to answer, and it appears to me that only by observing the character of the passages and noting the growth of the child can we intelligently decide. One evacuation each day, in a small number of cases, may be sufficient, but frequently where this is the habit some of the deleterious results of constipation will be noticed. On the other hand, we have frequently noted from three to four movements each day, and have found, by actual weight of the child, a normal increase from week to week, with every other indication of good development. From one to four passages each day, then, would be regarded as normal. Deviations from the normal, such as an evacuation every time a napkin is changed during the first year of infant life, to a passage once in seven or eight days, and, in the older literature, a single passage once in several months or even in a year, have been noted. A gradual increase in weight and a general good condition of nutrition must be our guide in deciding this question.

Constipation is undoubtedly more frequent in adults than in children, but the habit, with all its attendant evils, is more frequent in children than one would suppose from the meagre literature on the subject. Exactly where, in children, constipation commences to be pathological is a difficult point to decide.

After considerable study, I have come to the following conclusions in regard to what should be considered normal evacuation of the bowels in infants and children. In infants it is perfectly natural for at least three or four evacuations of the bowels to take place daily; and, viewed from this standard, a nursing child having only a single passage each day would be in an abnormal condition. Between the first and the second year it is normal for two movements to take place daily. At the beginning of the second year, usually both movements from the bowels and the bladder become voluntary; yet occasionally we find children within the first year who regulate very fairly these functions, and later on in a child's life we find them taking on family peculiarities. In all probability, what we call family peculiarities or hereditary tendencies are due more to neglect of the proper attention to the wants or habits of children, or to the perpetuation of a family habit of continually giving and taking purgatives. In every case it is necessary not only to inquire as regards this family peculiarity, but also to consider the character as well as the frequency of the intestinal discharges.

*Frequency.*—Nearly all children suffer in some degree from constipation. It is "an unpleasant and not rare occurrence." Some authorities state that it is one of the commonest disorders of early life. In many cases it is only a transient difficulty, while in others it is a malady which will follow its little victim through the entire period of childhood, affecting not only its present health and comfort, but also its future development.

Interference with normal peristalsis, which may come from many causes, will produce most remarkable variations in the normal evacuations as well as in the nutrition of the child.

*Quantity of Fæces.*—According to Bouehard, a baby passes about two

and a half ounces of fecal matter daily. This, in proportion to its weight, is much more than is evacuated by the adult. In the middle part of childhood the intestinal passages become more like those of the adult, although much depends upon the diet. A larger amount of food relatively is taken by a child than by an adult. It is not retained in the bowels as long as in the adult; consequently less time is given for its absorption. It is a well-known fact that while the food is in the stomach and intestinal tract of a child absorption is rapid, and the feces of children suffering from constipation are almost always dried or changed in a very remarkable manner.

**Etiology.**—In the first place we will consider more particularly the causes of constipation in infants at the breast, then in older children.

Besides the anatomical and physiological peculiarities which I have already enumerated, and the mechanical obstructions and congenital malformations mentioned elsewhere, there are many causes, more particularly relating to the diet of children, which produce constipation. First, a constipated habit on the part of the mother frequently has to do with the constipation of the child. The mother's milk sometimes contains too much casein, or too little sugar, and in other cases is so thoroughly digested that but little residue remains and constipation ensues.

A sluggish condition of the muscular coat of the intestine, a diminution in the secretions either from the mucous membrane or from the glandular apparatus, and improper food are other causes, to which may be added the imperfect muscular development in feeble and delicate children.

In order that there shall be a free and normal movement of the bowels there should be considerable fecal matter in the colon: not only must we have automatic peristaltic action, but there should be, it appears to me, the stimulus which comes from an adequate amount of fecal matter. It is useless, then, to expect a movement of the bowels within several hours following free catharsis.

An inflammatory condition, causing more than the usual amount of edema, producing a constriction of the circular fibres, may take place and cause constipation. This form of constipation simulates stenosis. To differentiate, one should remember that if vomiting takes place it will not be of the stercoraceous variety.

Artificial foods, including condensed milk, in many instances produce diarrhoea, but in other cases give rise to constipation; and any food which is absorbed quickly, leaving little or no residue, will produce this condition. To obviate this, if water has been used as the diluent, oatmeal-water should be substituted.

In older children a solid food, or vegetables with a large residue, or fruits, such as bananas, with an insufficient amount of liquids, in connection with a condition of the bowels favoring retention, are frequent causes of constipation. Over-stimulation and consequent atony of the bowel, whether from coarse food, frequent purgations, or large enemata, are causes.

Among other articles of food which may produce constipation are rice,

arrow-root, boiled milk, and tea. Impaction of the bowel, more particularly in the lower part, may take place from a variety of causes, such as large masses of hardened fecal matter, fig-pits, and stones from fruits. It is believed that intestinal worms (generally the lumbricoids) will give rise to the condition described.

Deficient intestinal secretion, by producing a hard and pebbly condition of the fecal mass by the time it reaches the colon and rectum, causes constipation. Where there is a deficiency, particularly in the bile or other secretions, and articles of food which cause fermentation are taken, an enormous accumulation of gas may take place, producing not only constipation but sometimes convulsions.

Excessive perspiration, either in the course of diseases or produced by the action of baths or drugs, may also be a cause of constipation.

All kinds of medicines administered to quiet pain or restlessness, whether prescribed by the physician or given surreptitiously by the nurse, are constipating. The same may be said of many of the tonics which contain astringents, particularly tannin; and one authority speaks of toys containing lead as a possible etiological factor. In this connection I should add the too free use of aperient medicines, producing over-stimulation and subsequent enfeeblement of muscular activity.

All local diseases of the rectum, as fissures and hemorrhoids, producing painful passages, predispose to constipation. The child delays its normal movement from dread of stool on account of pain, and soon there results distention of the lower bowel from accumulation, which, although secondary, produces the malady under consideration.

A neglect to inculcate a habit of regularity in going to the closet, the false modesty which is frequently felt by young girls, the inactivity of indoor life, and a want of exercise, induce constipation. In young girls subject to constipation we almost invariably find anaemia and neuralgia.

Constipation also arises from hernia, intussusception, intestinal obstruction from carcinoma, and congenital malformations of the rectum. It may be caused by chronic peritonitis, by tumors, and, in the female child, by a retroflexed uterus.

We may also include the constipation which occurs in meningitis, in myelitis, in hydrocephalus, and in micro-cephalic children. The bowels are sluggish in diseases of the cerebro-spinal system, due in part to interruptions in the motor nerve-currents or to a state of tonic contraction in the abdominal and intestinal structures.

All kinds of obstructions produce constipation, but, from lack of space, only a few can be here enumerated. Dr. Cheever relates a case of recurrent constipation first noticed a few days after birth. The anus and rectum were found normal, and at this time no abdominal tumor could be detected. The stools were of usual size, showing that the obstruction was above the sigmoid flexure. The trouble was overcome for the time by cathartics, but when the child attained the age of two years he again came under the

doctor's observation. The child's appearance was remarkable: the head was small and the lower part of the abdomen large; he was cone-shaped. He was fairly nourished, but from time to time he would suffer from intestinal obstruction, pain, and vomiting. An operation, with restrictions on the part of the parents, was resorted to, with the result of finding a dilatation of the intestines, containing about two quarts of fecal fluid. One end of the dilated bowel was attached to a piece of contracted and strictured intestine, quite impervious to solids, twelve or eighteen inches long, ending at the sigmoid flexure. This case demonstrates that fluid feces may come through a constricted portion and assume their normal consistency and shape either in the sigmoid flexure or in the rectum.

Finally, in many of the chronic and wasting diseases, especially those enfeebling the muscular movements having to do with defecation, and, in general, producing a low condition of the system, constipation is present.

As a most valuable contribution to our knowledge of the etiology of constipation, I present a condensed table from L. Martineau's elaborate article on the subject as it relates to children.

#### A. CONSTIPATION FROM DISTURBANCES IN THE CONTRACTILITY OR SENSIBILITY OF THE INTESTINAL AND ABDOMINAL WALLS.

*I. Constipation from Paralysis of the Intestines.*—1. Affections of the intestines.—Constipation may result from either primary or secondary (by extension from the mucous membrane) inflammation of the muscular coat. It is not uncommon to find in children ulcerations of the mucous membrane, which had previously caused diarrhoea, suddenly give rise to considerable abdominal distention and a most obstinate constipation.

2. Affections of the peritoneum.—Paralysis of the intestines from these causes is much more frequent than from the preceding. According to Barthez and Rilliet, in acute peritonitis in children, constipation is the exception and not the rule. Duparcque, on the contrary, asserts that constipation exists in the majority of cases. In chronic tubercular peritonitis, constipation never persists throughout the disease: it alternates with diarrhoea.

3. Affections of the nervous centres.—(a) In diseases of the brain and its membranes,—as in tubercular meningitis, where constipation is almost always the rule, and sometimes in acute meningitis; in serous or hemorrhagic meningeal effusions; in softening of the brain; in cerebral congestion or hemorrhage; in tumors of the brain. (b) In affections of the cord or its membranes, as spinal meningitis, congestion or hemorrhage, acute and chronic myelitis, and tumors,—which are more often the cause of constipation than are cerebral affections. A most obstinate constipation, due to paralysis of the sphincters of the anus, sometimes marks the onset of locomotor ataxia.

*II. Constipation from Paralysis of the Diaphragm or of the Abdominal Muscles.*—Neuralgia of these muscles, by preventing their action,—the least

motion occasioning pain,—leads to constipation. Hyperæsthesia of the abdominal muscles, so common in the hysterical, would act in like manner; so also would herniæ, which, owing to the risk incurred, prevent patients from exerting sufficient force.

*III. Constipation from Reflex Intestinal Paralysis.*—This may be the result of (a) affections of organs more or less in the vicinity of the intestines,—as a testicle, retained in the inguinal canal, becoming inflamed; (b) affections of organs connected with the intestines, as hernia of the vermiform appendix, umbilical hernia, and abscess in the iliac fossa. A proof that constipation resulting from the above causes is reflex is afforded by the fact that the phenomenon of paralysis is preceded, as in all reflex paralyses, by signs of irritation, as pain, vomiting, and abdominal distention. To the above causes may be added (c) lack of sensibility in the mucous membrane of the intestines. The result of this is seen in persons who do much brain-work or lead a sedentary life, and who make an abuse of rectal enemata or of certain medicines, as opium, purgatives, etc., which eventually act by diminishing sensibility or producing atony of the mucous membrane. Opium, however, would cause paralysis of the muscular coat. To this loss of sensibility of the mucous membrane must be ascribed the constipation so frequently met with in hysterical girls.

*IV. Constipation from Exaggerated Contractility of the Intestines.*—Spasm of the intestines becomes an impediment to the passage of its contents. Under the name “spasm of the intestines” Billard has described an affection accompanied with constipation, which affection, according to him, is quite common in new-born babes. Spasm of the sphincters may act in a similar way, and is usually the result of fissures, sometimes of hemorrhoids.

*V. Constipation from an Altered State of the Blood.*—This cause produces constipation either by its effects on the intestinal secretions or by its direct influence on the nervous system. Thus, in convalescence from acute diseases we may have paralysis of the muscles of the intestines as we have of other muscles. Maingault and others have observed this phenomenon after diphtheria. There occurs in certain cases paralysis of the rectum. Whether this paralysis is due to an altered state of the blood is yet a question.

## B. CONSTIPATION FROM DISTURBANCES IN THE GASTRO-INTESTINAL SECRETIONS.

*I. Causes interfering with Chymification.*—(a) Cancer and ulcer of the stomach; (b) gastritis, acute or chronic; (c) insufficient alimentation and improper food and drink,—frequent causes in children; (d) moral causes, physical suffering, vicissitudes of all sorts,—in a word, all causes of dyspepsia.

*II. Causes interfering with Chylification.*—(a) Duodenitis and acute enteritis; (b) fevers; (c) intestinal dyspepsia; (d) hepatitis and cirrhosis of the liver; (e) catarrh of the bile-ducts.

## C. CONSTIPATION FROM MECHANICAL OBSTRUCTION.

*I. From within.*—(a) Foreign bodies introduced; (b) worms,—both these causes are particularly present in children; (c) gall-stones; (d) polypi; (e) large hemorrhoids; (f) invagination, volvulus, etc.; (g) abnormal flexures; (h) diminished calibre of the intestines from hypertrophy of its coats or new growths.

*II. From without.*—(a) Compression of the intestines from enlarged organs or tumors; (b) strangulation by bands or in hernial sacs.

**Pathology.**—This part of our subject has not been well worked out. Indeed, until recently but few articles had been written upon the subject as it relates to children. Many valuable facts have been brought out, but in only a few instances have they been tabulated or made available to the profession. While it must be admitted that constipation may exist in children for years and no alteration of the parts be observed, on the other hand, not only is its existence frequently accountable for the lack of development, but its effects are far-reaching, as is demonstrated by some of the distressing ailments of advanced childhood.

Constipation affects different children differently. The full-blooded and bilious child needs more frequent evacuation than the spare and anæmic one. It seems to be clearly established that the retention of meconium will occasionally produce convulsions. Schlumberger cites cases which demonstrate this beyond any reasonable doubt. In this connection should be mentioned the opinion and clinical observation of Lazzar-Rivière. He believes that constipation comes in the list of reflex causes of eclamptic attacks, and records the case of his grandson, who died of convulsions caused by an obstinate constipation of only a few days' duration.

Since it is impossible to determine definitely when constipation commences to be pathological, the only correct measure will be found in the evil results of imperfect defecation; and this will be seen to differ greatly as we examine different cases. Sometimes we find, as remarked above, absolutely nothing; while in other cases the intestinal mucous membrane presents a simple hyperæmia, or various stages of catarrh or ulceration. We have also called attention to certain anatomical and physiological peculiarities as etiological factors: thus, we observe, when they are present, changes in the position, size, and walls of the intestines. I need not again refer to the displacement of the colon, particularly the transverse, and to the dilated condition of the sigmoid flexure. In chronic constipation the walls of the bowel become thin, and Johnston believes that in long-continued cases a fatty degeneration takes place, which explains to a considerable extent the loss in the contractility and propelling power of the intestines. In infants we find constipation producing repeated attacks of colic, which may disappear without alarming symptoms if speedily relieved, but if long continued bring about a swollen and distended condition of the bowels. The liver may be pushed upward, and in some cases the dia-

phragm interfered with, so as to cause symptoms referable to the respiratory apparatus.

Prolonged constipation in the young child produces disease in the cæcum,—chronic inflammation, and in some cases induration and thickening. Perforation of the intestine occasionally takes place. Among other serious consequences that sometimes occur are the different forms of hernia, varicocele, prolapse, fissure, catarrh of the bladder, spermatorrhœa, and particularly hemorrhoids.

In addition to the conditions spoken of above and referable particularly to the digestive tract, we have symptoms of pressure on blood-vessels, producing at one time a hemorrhoidal tendency and at another a slight œdematous condition of the feet and ankles. The nerves in the pelvis may also be pressed upon by fecal masses, and disturbed sensibility—formication, weariness, pain, or weakness in the lower limbs—be the result.

Chronic constipation with accumulation produces not only dyspnœa, but also disturbances in the thoracic circulation. Palpitation, irregularity of the pulse, and vertigo frequently result; and in anæmic girls we find rebellious headaches, hypochondria, and morbid thoughts. The same cause, when present in the lower part of the abdomen, produces in a few cases difficult and frequent micturition.

The relation of constipation to the nervous system, and the influence of the latter on digestion and the general nutrition of the body, are set forth by Martineau as follows. The nervous system and the blood play a very important rôle in the process of digestion, since they preside over the secretion of the juices necessary for the metamorphosis of food, and over the contractions of the intestines so essential to intestinal absorption. Let that secretion diminish or stop through changes in the blood or through lesions of the nervous system or of the glands themselves, and elaboration of food will no longer take place, and constipation will be one of the resulting disturbances. Or should peristalsis of the intestines cease, owing to failure of the sympathetic to act, or to its exaggerated action, to altered state of the nervous centres, or to paralysis or enfeeblement of the abdominal muscles that assist peristalsis in expelling the feces, the act of defecation could not take place, and constipation, with all its attendant evils, would result.

Habits of constipation due to neglect in school-days will frequently follow a patient for years, and have much to do with the production of chlorosis in girlhood. There have been during early growth and early development a poor appetite, poor digestion, and constipation, and, as a consequence, greatly-impaired nutrition, impoverished blood, and a resulting anæmia. Again, where a part of the contents of the bowels is habitually retained, a greater or less fermentative action may be set up and effete and poisonous matter be absorbed, producing those symptoms of indifference and inactivity, want of appetite, etc., which are sometimes noticed in children.

So far as my observations extend, bacteria play little if any part in the

production or in the evil effects of constipation. Casein is not changed at all by bacteria; and the same may be said in regard to the fats. Sugar of milk, however, is changed by being split up into the various acids: this takes place in the upper part of the small intestines. The process of decomposition going on in the intestinal canal during the course of a milk diet is to be regarded less as a putrefactive process than as one of fermentation, and the multiplication of bacteria, which we know takes place in the colon, is not at the expense of ingested food, and consequently is of no importance in the consideration of the nutrition of nurslings or of the constipated habit.

**Symptoms.**—Symptoms are not numerous in acute constipation. In the chronic form they are found in greater numbers, and, except in very rare instances, exercise a much more baneful influence on the immediate health and development of the child.

Occasionally acute constipation will produce a condition which may jeopardize the health, if not the life, of the child; but this is not usual. In the chronic form, as we have pointed out in the section on pathology, serious lesions affecting important organs are frequent.

A single evacuation each day, attended with straining, in a nursling is constipation, which in many cases inclines to become worse until a movement of the bowels can be produced only by medicines or injections. The usual symptoms found in such a case would be the infrequency of evacuation, the slight hardening of the feces, and the difficulty of their expulsion. All other symptoms might be functional, which would vary according as the case became chronic and the bowels became replete, or as the constipation was caused, as it sometimes is, by complete emptiness of the intestine. One writer has described the constipation of a single day, which is of particular importance in a robust child into whose alimentary canal a proper amount of food is taken. These symptoms are diminished appetite, increased volume and resonance of abdomen, colicky pains, fulness, and a feeling of weight in the lower bowel. If this continues for another day the face is flushed, the head somewhat hot, and the child nervous. In very young children we sometimes notice a pallor of the face, and, rarely, a jaundiced condition of the skin; indeed, a true jaundice sometimes supervenes, from pressure on blood-vessels and consequent obstruction. With symptoms as severe as those just mentioned the general nutrition of the child would suffer, and reflex action, such as convulsions, might ensue. Constipation in children under two years of age sometimes causes symptoms which simulate very severe disease, more particularly referable to the nervous system,—such, for instance, as high fever with slight facial convulsions and grimaces.

In older children the loss of appetite is more marked, the furred tongue (of minor importance in the nursling) is more pronounced, the breath is offensive, and the child has headache and colic and rests badly at night. The complexion loses its clearness, and the child is listless and morose.



Usually, however, in nurslings we find constipation producing only slight colic, some distention of the abdomen, and slight straining at stool. In older children the objective symptoms are more noticeable, and there is loss of appetite, with a coated tongue and bad breath, more or less lassitude and headache, and a feeling of heat in the face and head. The desire to evacuate the bowel is not so frequent nor so pronounced as usual, and where efforts are made only small, hard pieces of fecal matter are expelled. In these cases there is a feeling of fulness and pressure in the rectum, and sometimes the anal opening is found red and excoriated.

In some forms of constipation there occasionally occurs a peculiar kind of diarrhoea, produced as follows. The hard faeces acting as foreign bodies provoke a more or less abundant fluid secretion, which finds a point of exit either between the faecal mass and the intestinal wall, or through a lumen dug out of the faecal accumulation (Racle). Thus an obstinate constipation, with retention of immense masses of excrementitious stuff, may be mistaken for, and treated as, a case of diarrhoea.

In still older children,—those approaching youth,—if constipation has become a habit we find, in addition to the objective symptoms already described, others, which produce disturbances by pressure and have also a depraved influence on nutrition. Along with a distended abdomen, furred tongue, hot mouth, offensive breath, headache, and sometimes vomiting, there is such a degree of abdominal distention that some of the internal viscera are displaced, breathing is difficult, and in girls a condition is present which in after-years may develop a displaced uterus. Pain and uneasiness referred to the bladder are produced, and, from this and other causes, bladder- and kidney-troubles have been suspected when only constipation existed.

In some cases a general cachexia, persistent and significant, is produced, and symptoms referable not only to the alimentary canal but also to the nervous system and general nutrition are most noticeable.

In some children, where constipation has become habitual, there is a change in habits and character. Those fond of work and study can do nothing, on account of a persistent headache, and, while no physical signs of disease can be found, they are morose and melancholy.

The constant bearing down which is present in chronic constipation may produce hernia, hemorrhoids, fissures, and other symptoms referable to the rectum. The presence, too, of faecal masses for a long time in the rectum may produce follicular disease of the lower bowel, and, in some cases, diphtheritic patches.

In a few cases the colon has become so enormously distended that, with the pain and tenderness, peritonitis has been simulated, and, with an obstruction formed by oedema or from other causes, the colon has appeared to fill nearly the entire abdominal cavity. Indeed, to such an extent have these enlargements attained that a diagnosis of chronic peritonitis and tabes mesenterica has been made.

Stubborn constipation may give rise to fecal accumulation and symptoms of intussusception. Marmaduke Shields narrates a case in which small motions "like pebbles" were passed; then came incessant vomiting, discharge of blood and mucus from the bowel, and prolapse. Syncope occurred, with profuse sweating, and death seemed imminent. At this time a hard, irregular swelling in the left lumbar region was discovered, and an examination per rectum established the diagnosis of accumulation and impaction. This leads me to say that in making a diagnosis of fecal tumors we must consider their location, their consistency, and one's ability usually to change their position. We should observe, also, the influence of treatment, particularly of repeated injections. If the tumor is well down in the bowel, we should notice the gradual lessening in size as the small, hard fecal masses are loosened and brought away by the injections.

**Diagnosis.**—It should always be remembered that a small amount of fecal matter evacuated by a child whose alimentation is insufficient as regards quantity should not be regarded as indicating constipation. The presence of this condition will usually not be difficult to establish. In the acute variety there will be infrequency of normal passages from the bowels, pain upon pressure on the abdomen, accumulation of gas, a coated tongue, and a hot mouth.

We should not count as constipation the inability to perform the act of defecation which results from congenital defects or surgical obstructions. These will be treated elsewhere.

In chronic constipation we may be obliged to base a diagnosis more upon the effects previously produced than upon the symptoms actually present. The continued tenesmus or the presence of hemorrhoids or of a hernia will, in many instances, suggest the trouble.

**Prognosis.**—As regards life, I have always regarded the prognosis as good, although Bouchat believes that in one case constipation caused death; at least no other cause could possibly be assigned. It is in its consequences, both immediate and remote, as causing sickness and improper development, that constipation becomes at times serious and possibly dangerous. This condition, when existing in only a moderate degree, produces slight stomachic disturbances, distention, and tenesmus, and is but a transient or trivial affair. This same condition, however, coming to be more pronounced causes fever and restlessness with its possible sequela. Convulsions take place not only from a slight constipation when the irritant is active, but frequently also from the retention of large fecal masses. In my judgment, a convulsion is always dangerous, by whatever cause produced. A stoppage of the bowel temporarily by food or fruit will nearly always produce restlessness and frequently night-terrors. An extreme nervous condition, bordering on a convulsion, is often noticed in a comparatively healthy child with a nervous temperament, who, suffering from constipation, fears the pain incident to a movement of the bowels. Many of the so-called sick or nervous headaches of children are caused by fecal absorption, and, while

the constipation may be constant, the symptoms of poisoning or the convulsion produced may only be periodical or occasional.

As the child becomes older, if a constipation is neglected or improperly treated, the probabilities of its producing ill effects are increased. In infancy, if the diet is changed and the attention given which the subject demands, a constipation will usually be cured, but if it exists without attempts at its amelioration in older children it is liable to become chronic, influencing the general development, and, in female children, giving rise to uterine displacements.

*Prognosis in Chronic Constipation.*—As to life, this is also good, but locally it produces diseases of the rectum, hemorrhoids, fissures, and herniæ. In some cases such a degree of stenosis is produced that the most serious results are anticipated, and laparotomies have been performed with the expectation of finding intussusceptions, etc. To avoid such mistakes, which, previous to the days of antiseptics, certainly jeopardized the lives of patients, a very large injection of water or insufflation of air should be made before the operation is commenced.

**Treatment.**—The number of drugs administered for the relief of constipation in infants is surprising, if not alarming. Castor oil, gray powder, calomel, senna, scammony, jalap, podophyllin, belladonna, rhubarb, cascara, besides the favorite powders of the different doctors, are all given in various combinations. For the nursling, in the majority of cases except in an emergency, they are useless, and should be discarded. The indications are to correct the condition either by attention to the mother or by a slight change in the food of the child, and to avoid laxatives.

After excluding congenital defects we should look to the mother for the cause. If an evacuation of the bowels does not occur within twenty-four or thirty-six hours after birth, a careful examination of the anal opening should be made; indeed, in some of the large lying-in hospitals a very small enema is given as a part of the baby toilet at the first dressing. This demonstrates at once the perviousness of the canal. Next let the mother be examined for a cause of constipation, and, by changing her diet, seek to correct her baby's habit. It may be necessary to administer a mild laxative to the mother; for, as a rule, simple constipation in the child should be overcome without giving it medicines or injections.

If a child has been provided with a wet-nurse and is constipated, the question will arise as to the propriety of changing to a wet-nurse with younger milk, in order to furnish more colostrum and less casein. Of course everything of a constipating nature, including starchy foods, is to be excluded from the diet of mothers or wet-nurses whose children are constipated.

If, notwithstanding these directions, the habit persists, and the child has but a single dry passage each day and this is attended with straining, some exceedingly simple remedy should be administered to the child. As the simplest of laxatives, I strongly recommend a little molasses or simple syrup in

water, and where the passages are very dry and the child is known to perspire freely, we should suspect an insufficiency of water in its system, and to overcome this there is nothing better than pure water internally. I desire to emphasize this point. It is an affliction to deprive a child of water. It is not only a cause of constipation, but the deprivation of water sometimes amounts to absolute suffering on the part of the child. A baby is not always hungry when it cries; it may be thirsty. To feed a child when it is only thirsty, and not give it water, will sometimes aggravate a constipation. Let it be remembered, then, that one of the most efficient remedies in the treatment of children is water given two or three times during the twenty-four hours. To a child accustomed to a mixed diet, in place of water, oatmeal-water may be given for a time, in order that the child may be nursed less frequently.

If the measures already suggested do not give relief, of course other treatment must be adopted, and we come to consider local stimulants which may be introduced into the anal opening or into the rectum. Among them I notice the soap or gluten suppository, molasses boiled and moulded into little masses and introduced, and the nozzle of a syringe oiled and inserted and injections of very small quantities of glycerin or water or both combined. Bohn recommends, as preferable to any of the foregoing, injections of cold water three times, if needed, each day, then twice a day, and finally once daily until the cure is assured. Other authorities advise cold water as the injection, to which may be added a small amount of common salt. If enemata are necessary, either warm or cold, use small quantities, one or two fluidrachms of water, or from ten to twenty drops of glycerin to which may be added a little water. Large injections of any fluid should be avoided, because they not only dilate the colon and paralyze the lower bowel, but sometimes also produce discomfort in infant patients by crowding against internal organs and producing, among other symptoms, difficult respiration and interference with circulation.

As the child develops, and particularly as the process of dentition commences, a constipation which has been troublesome is sometimes entirely overcome. This is true if laxative medicines have been avoided and the bowel has not been injured by very large injections. In a few infants growth and nutrition seem to progress in every respect naturally with only a single passage each day, and with such it is not necessary to interfere. If drugs must be given to the nursling, nothing will yield better results than minute doses of calomel, or small doses of castor oil or of magnesium carbonate—gr. x to xv to  $\bar{5}$ i of water and syrup—given in teaspoonful doses *pro re nata*; or a grain or two of the magnesia may be given in a little sweet milk.

In older children some cause may be apparent which could not be discovered in a nursling. It is needless to say that in all cases this should be removed.

In older children, too, we should see to it that the endeavor is made to

inculcate the habit of regularity in attempts to evacuate the bowels. When fecal matter descends into the rectum, producing some sort of irritation or fulness, as it does in older children when the effete stuff comes to have a greater consistency, nature should be listened to, and the evacuation encouraged by a daily regular habit. If these promptings are disregarded for a long time, they are liable to cease; the sensibility of the part is diminished, and a constipation difficult to cure is the result. A child of two or three years, and sometimes even younger, may be taught to expect an evacuation of the bowels at some regular time; and with this expectation and a regular habit it may be taught to exercise its will. Let there be, then, a co-operation of habit, expectation, and will, before we think of drugs. It is in children of this age that massage and methodical irrigation of the bowel are so highly beneficial. Baginsky prefers this treatment to any other; the same author deprecates suppositories, particularly the soap, as tending to produce local inflammations.

Children on a mixed diet should avoid the starchy foods and eat more soups. Use water freely, and a varied diet; let the food be somewhat coarse, well masticated and swallowed slowly; and avoid giving the same food repeatedly. If the digestion be good, more milk may be added to the food; a little oatmeal will increase its coarseness and a few drops of molasses make it slightly laxative. This may be changed from day to day to mush made from unbolted wheat-flour or corn-meal, or to bran in bread and milk prepared by soaking the bran in the milk, warming, and then adding the bread. Whey, when it can be obtained, is of great benefit. To children two or three years of age, stewed fruits or baked apples may be given. Small amounts of fruit, particularly grapes without skin or seeds, are now admissible, or figs, the Tamar Indien, and purgative biscuits made by the French. At this stage we advise home gymnastics, particularly if the nutrition is below grade, swimming, and salt-water bathing if possible. In any case, however, do not expect too much; ascertain the amount of food taken daily, and do not look for a greater quantity to be excreted.

Among the drugs which are useful in children of this age is calomel in small doses. Children invariably bear this drug well, and habitual constipation is always relieved by its occasional administration. It should not be given habitually to those afflicted with the strumous or rachitic diathesis. Castor oil or castor-oil paste,<sup>1</sup> or small doses of belladonna and of tincture of nux vomica, may be given; or the gray powder with a little bicarbonate of sodium, or powdered liquorice (pulv. glycyrrh. comp.) with sulphur, if there is any evidence of rectal irritation. The small doses of belladonna and nux vomica mentioned above will be found in combination very serviceable in giving tone to the bowel or for relieving spasm. According to some authors, these drugs also relieve flatus; in my judgment, however,

---

<sup>1</sup> Made by rubbing together powdered acacia, castor oil, syrup, and glycerin, and flavoring with anise, vanilla, or other aromatics.

nothing gives better results for this distressing symptom than magnesia and asafœtida.

The glycerin treatment which has been suggested for both nurslings and older children is an old remedy recently revived. According to Dr. Althaus, it was probably discovered by Dr. Oidman, who kept it a secret until it was purchased by Dr. Anacker, who analyzed it and brought it to the notice of the profession. The theory of its action is as follows: glycerin brought in contact with the mucous membrane of the lower bowel withdraws water from it and causes hyperæmia and irritation of the sentient nerves of the rectum: this produces powerful peristaltic contractions and defecation.

The family physician should see to it that the older children do not eat those articles which are known to constipate. Forbid spices, cheese, dried fruits, and the coarser dry foods. Do not advise medicine for failure to evacuate the bowel every day, but encourage the attempt, with attention to the diet; practise rubbing and order exercise. If drugs must be taken, find the one which agrees with the patient, and then the dose which causes an evacuation; then gradually reduce the quantity of medicine till the diet, which has been corrected, keeps the bowel in a normal condition. The fluid extract of cascara sagrada, in doses of one or two drops, will be found an excellent remedy. For a child of two years, clear out the bowels with a powder containing two or three grains of calomel with a little compound liquorice powder; follow for a few days with carbonate of magnesium (ʒii to water ʒi) one to three teaspoonfuls each day till the bowels are relaxed. Then give non-astringent iron preparations, nux vomica, and possibly magnesium sulphate or cascara, until the cure is complete. Dr. H. H. Clark, of Iowa, believes that ipecac in one-grain doses, either alone or with small doses of calomel, is the remedy *par excellence* for constipation in children.

The headache and coated tongue, the nervous and feverish symptoms, and the dizziness, which we find associated with constipation and possibly diagnosticate as biliousness and indigestion, cannot easily be cured by bromides and neurotic remedies. First clear out the bowel of its accumulated filth, then give a remedy to act on the secretions, and afterwards give iron, nux vomica, and magnesia.

In constipation which has persisted for a very long time, with great distention of the bowels, the abdomen may be bandaged to aid in restoring tone. Galvanism or electricity may be used. In excessive distention, with symptoms of collapse and much heart-displacement, we may resort to puncture of the colon with a hypodermic needle.

Sometimes it will be necessary to produce a diarrhœa for some days in order to unload the colon.

Whenever the colon is blocked it must be cleared by the use of enemata. In chronic constipation always make an examination of the rectum: it sometimes reveals much to help in the diagnosis. Congenital deformities, never suspected, have been thus discovered.

If electricity is used, it should be remembered that Schillbuch (quoted by Jacobi) has found that the several portions of the bowels respond differently to the application of the faradic and of the galvanic current : the galvanic is usually the stronger. Local contractions result from the negative pole, peristaltic waves from the positive. Apply the negative pole in the rectum, and the positive over the abdomen along the colon. By massage or gentle kneading of the abdomen over the colon and in the direction of its peristaltic movements, muscular action is stimulated and the desired results are frequently brought about. This process should be repeated two or three times a day.

The treatment of constipation occurring as a complication of other diseases demands more space than is allotted to me, and a few words must suffice.

Cod-liver oil and syrup of the iodide of iron are particularly useful in the rickety and strumous diatheses. The oil is one of the best remedies for these diseases, and acts well for the constipation which is frequently incident. Indeed, cod-liver oil, two parts, and lime-water and the syrup of the lacto-phosphate of calcium, each one part, are regarded by Prof. J. Lewis Smith as meeting as many indications in the ordinary constipation of children as any other combination.

Children with indigestion associated with constipation should always have first a corrected diet, then pepsin in combination with muriatic acid, and cascara or compound syrup of taraxacum.

In anæmic children the mineral waters containing iron are particularly recommended by the Germans. The Friedrichshall is claimed not only to have saline aperient qualities, but also to be a tonic: it influences tissue-changes and promotes the excretion of uric acid. A mixture of sulphate of iron, sulphate of magnesium, and tincture of nux vomica will be very serviceable in these cases.

It is almost needless to say that accumulations of faecal matter must be removed by the more powerful cathartics and by regular irrigation, which sometimes must be carried into or through the mass by means of a tube. An impacted rectum must be cleared by the use of the syringe, and occasionally digital assistance will be required.

# TABES MESENTERICA.

By A. JACOBI, M.D.

---

THE names by which diseases are known in modern pathology have come to be derived from their pathological anatomy in the same degree that local diagnosis has been brought nearer perfection. Symptomatic diagnoses and symptomatic terms are becoming rare; though it is true that there has crept into nomenclature an equally unscientific habit, which consists in applying to a newly-observed disease or complex of symptoms the name of their first observer—or inventor. Many formerly accepted as nosological entities have been given up as such; when we speak of dropsy, paralysis, convulsion, neuralgia, epilepsy, or atrophy we know perfectly well that we have to deal with a symptom, or a number of symptoms, requiring etiological details for their exact recognition, and special and varying indications for the treatment of individual cases. But until a very late period “tabes mesenterica,” or “tabes mesaraica,” has been accepted as a term applicable to a particular set of symptoms and limited anatomical changes by which it could be easily recognized. The following pages will be dedicated to showing that the pathological anatomy of mesenteric tabes is by no means the same in all cases, and that the term itself ought either to disappear entirely from our indexes or be recognized as merely a convenient expression for a complex of more or less similar symptoms.

Among those, mostly older, celebrities who were of the opinion that imperviousness of the mesenteric glands was a satisfactory explanation of tabes mesaraica, that patients die because the lacteals are no longer able to take up from the food a sufficient supply of nutriment, and that they die of starvation, are Thomas Watson, Cullen, and Bichat. The latter modified the general opinion in this, that he defined tabes (*carreau* of the French) as the engorgement of the glands of the abdomen, mostly occurring between the second and eighth years, painful or painless, complicated with digestive disorders, distention, diarrhoea, and vomiting, which, however, did not result in the non-absorption of chyle except in the later periods of the disease.<sup>1</sup> Cruikshank, as early as 1790, thought this blocking up of the lymphatic circulation very improbable, and Guersant formulated his hesitation in accepting the exclusive obstruction theory by declaring that the

---

<sup>1</sup> W. T. Gairdner and Joseph Coats, Lectures to Practitioners, London, 1888.



very diagnosis of the condition of the glands was always difficult; that the examination of all the viscera often resulted in the discovery of changes which led to the results attributed to glandular disorders exclusively; that he was not aware of a single case of disease of the mesenteric glands not attended with complications; that, moreover, there were many glandular disturbances without nutritive disorders; and, finally, that the mesenteric glands were not the sole roads for the admission of chyle. Besides, in his own reports, and in those of his followers, and in the experience of all those who have compared morbid symptoms during life with the evidences of post-mortem examinations, there are many cases in which, together with the glandular changes, or independently of them, the acute, subacute, or chronic inflammation of the peritoneum, either general or local, and mostly of a tubercular character, was the only anatomical anomaly underlying the symptoms of "mesenteric tabes."

**Symptoms.**—The main symptoms common to every form and case of "tabes mesenterica" are atrophy and tumid abdomen. Emaciation and atrophy reach a degree hardly ever met with in any other morbid condition. The subcutaneous fat disappears rapidly. The skin is thin, flabby, and inelastic; round the limbs it is loose and hangs like a bag; when taken up between the fingers it retains the fold raised in the lifting. In the beginning the muscles can be recognized; afterwards even they emaciate to such an extent that their outlines disappear, and those of the bones are distinctly perceptible. The eyes lie deep in the orbits, and have a peculiarly dry and hungry look; the bones of the face, with the thin, flaccid, dry and scaly skin over them, take on a terribly senile expression. The surface is mostly cool, the limbs are cold, the cutaneous veins very distinct and blue, much dilated over the chest and still more so over the abdomen. The voice is thin and tin-like, the cry mostly tearless, the pulse slow (from exhaustion of the heart-muscle) or more frequently rapid, thin, and compressible. The lymph-bodies of the neck and the inguinal region, sometimes also the axilla, are tumefied.

These symptoms are more or less common to all cases. There are many, however, which exhibit numerous variations in important particulars. Appetite may be ravenous or entirely lost. Some begin with little or no diarrhœa, but in all the stools are fetid. The majority, however, commence with a severe form of intestinal catarrh, attended with numerous offensive discharges. The peculiar odor, foul, musty, pungent, ammoniacal, is due in part to acids formed by the fat which has not been absorbed, sulphides, and other products of putrefaction. In the further development of the morbid condition there may be constipation, but diarrhœa is more frequent. It may not be very copious nor the evacuations very numerous. There is tenesmus in some, with but little substance; others are large, and expelled suddenly, in an instantaneous gush. The temperature is in some cases normal or even subnormal, in others elevated; when it is quite high, the cheeks and scleroticæ may become injected. The tumid belly is absolutely

painless in some, very sensitive in others ; the latter mainly in those who have an elevation of temperature. The large size of the abdomen, with its nets of dilated veins, contrasts fearfully with the atrophied condition of the limbs. It is large enough to press the diaphragm upward and interfere with the functions of both heart and lungs. The nature of the tumefaction, however, varies : it is tense or flabby, hard or soft, doughy or firm, uniform or irregular. Nodules or lumps of different shapes and sizes may be discovered by palpation. They may be spherical ; flat, so that the hand can be run under the cake ; superficial, near the abdominal wall ; or deep-seated, in close neighborhood to the vertebral column. Gentle percussion will reveal tympanites all over, both on the top of the protruding abdomen while the child is on his back, and in the flanks ; or there are one or more areas of relative dullness corresponding with a solid mass discovered by palpation ; or there is dullness in both flanks, varying with changes in position, thus indicating the presence of fluid, which, moreover, can be made out by its fluctuation. Great care, however, has to be taken lest the presence of solid tumors in a flank give rise to the diagnosis of fluid, or lest intestines containing gas which have been glued to the abdominal walls disguise entirely through their lymphatic percussion-sound the presence of ascites.

Other symptoms may be present, such as œdema, through thromboses in small veins ; extensive dullness belonging to fatty liver ; albuminuria and the usual microscopic changes of the urine encountered with nephritis ; local inflammations of the abdominal surface connected with abscesses which are occasionally, though rarely, the final stages of certain forms of peritonitis ; and cough depending on tubercular disease of the lungs.

The variety of symptoms belonging to "tabes" points distinctly to different morbid processes. The gradual beginning, slow and feverless course, with but little disturbance of the bowels and other organs ; the connection with a severe form of enteritis, continuation of diarrhœal discharges during the beginning and growth of tumidity, and moderate or high temperatures during the course of the morbid process ; and the tumidity of the abdomen, with emaciation following chronic cough and repeated attacks of catarrh, and terminating either in fatal exhaustion or in acute peritonitis, appear to prove that there are several distinct forms of "tabes," depending on different causes and attended with varying anatomical alterations.

**Pathology.**—Former essays in this work, particularly those of Dr. Ashby on serofulosis and my own on tuberculosis and phthisis, have explained the changes taking place in the lymph-bodies. Therefore only such brief remarks will be made here as refer directly to the mesenteric glands. Most of the first changes occurring in them are of an inflammatory nature ; they are secondary in character ; indeed, the primary changes are mostly neoplastic, and particularly sarcomatous. As in other glands, the inflammation may be a simple one and uncomplicated, or suppurative, or fibrous, or caseous, or tubercular. Simple adenitis is occasioned by any kind of irritation. Like an eczema of the head or a nasal catarrh which

lights up adenitis of the neighborhood, a simple intestinal catarrh, with diarrhoea from any cause whatsoever, produces it. The first change consists in dilatation of the blood-vessels, with reddening, softening, and succulence of the tissue, endothelial changes in the lymph-spaces, and new formation of cells. Afterwards the red discoloration is replaced by a grayish-white color, now and then interrupted by small blood-points which will turn into pigment, and the difference between the cortical and medullary substances fades or disappears. At the same time the capsule gets tense over its swelled contents. These are the cases which are amenable to a complete recovery. But suppuration, induration, or necrosis of the tissue is often met with. The latter is a frequent occurrence in typhoid fever, in which the lymph-bodies of the abdomen play a similar part to what we observe both more frequently and more extensively in the glands of the neck, under the influence of diphtheria.

Suppuration of inflamed glands is more frequent near the surface than in the abdominal cavity, where they are less exposed. Still, it does occur there, though mostly in putrid and septic processes. Caseous and calcareous degeneration is noticed in a certain number of instances.

Fibrous induration of lymph-bodies is of frequent occurrence in every region of the body. It is the usual result of repeated irritation. The constant hyperæmia of a chronic intestinal catarrh or of frequent acute attacks precludes the return to normal circulation. Then the substance of the glands becomes hard, dense, and white, the hyperplastic connective tissue compresses and atrophies the cells of the parenchyma, the capsule becomes thick and indurated, and the organ retains nothing at all of its former shape, size, and function. In this condition when the change has gone beyond cell-proliferation, and new tissue has been fully organized, it is no longer amenable to treatment.

The tubercular form of inflammation is very seldom of a primary occurrence. In it the diseased gland is enlarged, nodulated, and contains small round cells, or flat epithelioid cells with large nuclei, and frequently giant cells. The caseous and tubercular forms, while it was Virchow's original inclination to distinguish between the two, are considered identical, or mostly so, by Schüppel, Rindfleisch, Orth, Cornil, and Koch.

Though it is rarely of a primary character, tuberculosis of glands, both mesenteric and others, is frequent; but to render a gland tubercular there must be an absorbing surface accessible to the virus and ready to admit it. A healthy mucous membrane absorbs no poison. It requires an open wound, such as a chronic eczema, or a chronic bronchial catarrh, to permit of a free access to the neighboring gland. Thus it is that the glands of the neck and the tracheal and bronchial glands are so very liable to become tubercular. The mesenteric glands are less exposed. It is true that the tubercular poison may pass the stomach undisturbed, but it is certain that tubercular enteritis and adenitis seldom result from it directly. Indeed, even the diarrhoeas of phthisical patients, who swallow their own bacilli

constantly, are not so often of a tubercular nature as they are the mere result of the local irritation produced by the presence of copious pulmonary discharges on the intestinal mucous membrane.

Only when the local irritation has persisted for some time and produced erosions has a virus an opportunity to locate and fasten itself in the injured epithelial layer. In that case the tubercular invasion may lead to serious results though the lesions of the surface have healed.

Thus it becomes evident not only why it is that a primary tuberculosis of the intestine, and the secondary tuberculosis of the mesenteric glands, by the introduction of tuberculous food, may take place, but also why they are relatively rare. Indeed, the cases which appear to be conclusive are by no means so. For, while we may suspect that infected meat or milk has occasioned a tuberculosis, that very case may have been infected either through a wound of the lips, mouth, or throat, or by simultaneous inhalation. Thus the suspicion that a case is one of intestinal contagion is more readily entertained than it can be proved. Schottelius<sup>1</sup> fed ten families, consisting of one hundred and thirty persons, on tuberculous meat, which was taken raw sometimes, for two years; in eleven years none of them died of tuberculosis. Thus, while there is no doubt as to the occasional occurrence of tubercular infection by meat or milk, the cases must be well weighed before they are decided affirmatively.

Besides the simple secondary hyperplasia of the mesenteric glands resulting in obstruction, and the tubercular infiltration terminating in the same disturbance of function,—besides its infectious character,—there is a third condition which leads to the symptoms called “tabes mesenterica,” viz., chronic tubercular peritonitis. It is quite frequent, but its symptoms may vary in duration and severity. While the child is emaciated, sometimes to a fearful extent, the abdomen is tumid, elliptic, its surface shining, the surface-veins dilated, the umbilicus expanded and flattened. There is sometimes ascites; sometimes hard and circumscribed tumors, or the intestinal convolutions, may be distinctly felt or seen. This tumid condition is even liable to persist when tubercular meningitis makes its appearance in the course of time. There may be colic and diarrhoea, or they may be absent. The temperature may be normal. Slight changes in the afternoon ought to be ascertained by inserting the instrument into the rectum. This condition may last many months, even a year; it is capable of vast improvement, and may terminate in recovery, though with a low standard of vitality. This capability of recovery, with which the experienced practitioner and pathologist has long been acquainted, has surprised the surgeons, now and then, who opened the abdomen under a mistaken diagnosis, found tubercular peritonitis, sewed up again, and concluded that when the patient recovered it was because, and not in spite of, their uncalled-for operation. At the present time, however, we are justified in the belief that only those

---

<sup>1</sup> Virchow's Archiv, vol. xci.

cases of chronic peritoneal tuberculosis will have a chance which are local, and not the result of general tubercular infection.

**Diagnosis.**—In estimating the size and tumidity of a child's abdomen, we must not lose sight of the fact that it is normally larger in proportion than that of the adolescent or the adult. The child's pelvis and chest are less developed, its liver large. The shape of the abdomen is tun-like, its vertical length one-third of the length of the body, while in the adult the proportion is one-fifth. A high degree of tumidity may be due to constipation, mainly that form which originates in oversize of the sigmoid flexure, or in expansion of the intestine depending on muscular weakness. The main cause of the latter is rhachitis, the first principal features of which, when developed at an early date, are costiveness, meteorism, and flabby muscular texture. Other causes are flatulence depending on improper food and fermentation-processes in the bowels, or insufficient peristalsis, or the presence of scybala; also the presence of ascites depending either on cirrhosis or perihepatitis or generalized peritonitis, the first of which is the less frequent cause; or oversize of abdominal organs, such as the liver or bladder; also either cystic (urachus or echinococcus) or solid tumors. Among the latter fibroma, enchondroma, myxoma, and lipoma are quite rare and therefore not of clinical importance; carcinoma is not uncommon, but sarcoma is more frequent. There were, up to 1884, forty-three cases of sarcoma of the kidney on record.<sup>1</sup> Tubercular disease and tubercular tumefaction are very much more common. It is true that isolated tubercular tumors, mainly those of the mesenteric glands, are quite rare, but they do occur, uncomplicated or, mostly, complicated with other lesions of an inflammatory character. This complication of glandular enlargement with peritonitis may lead to very serious results, even beyond the tubercular infection. A girl of two and a half years, of healthy family, who previously suffered from aural discharges and measles, and afterwards from anæmia and general malaise, was taken with abdominal pain and distention, constipation, and vomiting of mucus and purulent material. She died after an illness of three days. The autopsy revealed caseous mesenteric and retro-peritoneal glands of the size of pigeon's eggs, bending upon itself and gangrene of the sigmoid flexure, peritonitic adhesions along the descending colon, the sigmoid flexure, and the rectum, and complete obstruction, by compression, of the ileum.<sup>2</sup> Similar occurrences are not at all rare, though mostly not so striking as the one just related. Indeed, adhesions between the intestines themselves, or the intestines and the parietal peritoneum, or peritonitic exudation with hemorrhages, or infiltrations of the omentum which result in hard nodulated tumors located above the umbilicus, are quite common, and form large masses together with the infiltration of the glands themselves. Such peritonitic exudations may be

<sup>1</sup> A. Jacobi, Sarcoma of the Fœtal and Infant Kidney, *Transact. Internat. Congress, Copenhagen, 1884.*

<sup>2</sup> Th. Pauli, *Jahrb. f. Kinderheilkunde, 1889, xxix. 77.*

either simply inflammatory or tubercular, small or large, hard or soft, local or generalized to such an extent as to fill the whole abdomen.

The diagnosis of tubercular peritonitis, or peritoneal tuberculosis, is apt to be quite difficult. There are many chronic cases which cannot be differentiated from non-infectious peritonitis and other inflammatory processes. Besides, many of the caseous tuberculizations are small, and thereby inaccessible to an accurate physical examination. They, and the rare cases of primary tuberculosis of spleen, liver, bile-ducts, peritoneum, and intestine, are to be inferred rather than diagnosticated. But there are cases of tumid belly with atrophy, of both an acute and a chronic character, in which the nature of the affection can be made out with some degree of certainty. When the distention of the stomach appears after an intestinal catarrh, when it continues after the diarrhœa has ceased in frequency, the stools either improving in character or remaining offensive, when the temperature remains high and the symptoms (occasionally) exhibit a "typhoid" character, with (now and then) delirium and frequently a dry tongue, the existence of an acute attack of tubercular peritonitis is probable. This diagnosis is rendered the more probable by the presence of some other symptoms. Among them are cough, sometimes slight, short, and hacking, sometimes moist and frequent; the presence of pulmonary symptoms or dullness over the manubrium sterni or below one or both of the clavicles, pointing to swelling of the tracheal or bronchial glands; a concomitant history of tuberculosis in the family; and a more intense degree of emaciation than the brief duration of an intestinal catarrh would justify. Still, mistakes are possible even then. The frequent complication of peritoneal tuberculosis with fatty liver and parenchymatous nephritis may obscure the clear comprehension of the case. "Scrofulous" glands occurring round the neck may be, and mostly are, non-tubercular, being the result of non-infectious irritation of the scalp or nasal cavities; the tumefaction of the inguinal glands is too frequent to be of much account. \*

**Prognosis.**—The prognosis is always uncertain except in the very worst cases. It is absolutely fatal when the "tabes mesenterica" means peritoneal and glandular tuberculosis complicated with, or depending on, generalized tuberculosis; when the temperature is permanently high, and exhaustion extreme; when diarrhœa remains copious and offensive, the heart very feeble, and the intra-abdominal exudation has resulted in very extensive induration. A case occurring in a healthy family, in a child that does not suffer from cough or other pulmonary complication, but develops its emaciation and tumid abdomen after a protracted, though uncomplicated, diarrhœa, furnishes a more favorable prognosis. For in such the diagnosis of a mere—non-infectious—hyperplasia of the mesenteric glands can be made with great probability. In such, even large indurations will be absorbed gradually. When the diagnosis of chronic peritoneal tuberculosis has been made, the case is less promising; still, in it the possibility of recovery, or partial recovery, is not excluded. Indeed, the results of laparotomies, such as have

been alluded to before, hold out a certain amount of hope even in those cases in which the diagnosis could be made with perfect accuracy.

**Treatment.**—A healthy infant or child cannot fall sick with any of the symptoms of “tabes mesenterica.” Thus prevention consists in taking all the measures calculated to preserve the general health of the baby. Foremost among them is the selection of proper food: all the rules and regulations detailed in other parts of this work, which refer to the raising on breast-milk and appropriate artificial food, must be conscientiously obeyed; farinaceous substances allowed in but moderate quantities; casein, which is a frequent irritant of the intestinal mucous membranes, limited to its proper percentage; and fat administered in no greater quantity than is contained in the natural nutriment of the nursling. Weaning is to take place at the legitimate time, which has mostly arrived when a few teeth have made their appearance. Good air and attention to the condition of the skin (cool bathing and friction, protection by warm clothing, and avoidance of draughts) aid in enabling the young to resist injurious influences.

The early symptoms of rhabdomyositis indicate a thorough anti-rhabdomyositic treatment (animal food, phosphorus, and iron), and diarrhœa, no matter from what cause, must be relieved immediately. Again I insist upon the danger incurred by allowing the catarrhal or inflammatory irritation of the mucous membrane to remain unchecked; for it is because of this that the neighboring glands begin to swell, or that bacteric invasion takes place. But not diarrhœa alone is connected with hyperæmia and its dangers; constipation also may be both the result and a cause of extensive congestion and irritation. Sometimes glandular swelling may appear without an apparent cause. In a healthy family the thirteenth baby, after having been subject to habitual costiveness, was laparotomized because of intussusception. Thus it happened that the mesenteric glands could be leisurely inspected and examined; they were swelled to the size of beans and hazel-nuts.

To prevent the tubercular form, cow's milk and meat must not be administered unless exposed to boiling heat. It is true that there are not many cases of infection by these agents, but the few ought to be avoided. Cream, buttermilk, and cheese cannot be submitted to the same preventive measure, and must be used with some caution. The different forms of scrofula (“erethic” and “torpid”) must be treated according to the methods discussed in other essays; it is in them that animal foods, malt, iron, cod-liver oil, and cereals without or with milk, are indispensable. Whenever possible, a change of climate ought to be advised. Local tuberculosis in glands or in bones must be extinguished by an operative procedure; and a chronic eczema should be made to heal.

In chronic cases, in which changes in the mesenteric glands can be safely diagnosticated and the existence of tuberculosis excluded, iodides largely diluted may be administered for a long time. The potassium, sodium, and iron salts have their own indications, and may be combined. They are particularly demanded in patients who have previously suffered from the torpid,

or adipose, form of scrofula. They may be used externally, in baths regularly given. It is here that natural springs, such as St. Catherine's and Kreuznach, can be employed to advantage. In the tubercular form arsenic ought to be administered in small doses for weeks or even months. Fat (cream, cod-liver oil) does better here than in the simple hyperplastic form, but in every instance we ought to remember that indurated mesenteric glands absorb but a small quantity. Whenever enteritis remains active, the eroded or ulcerated mucous membranes require antifermentative treatment. In that chronic form small doses of calomel are less efficient than bismuth, with or without resorcin, and small doses of opium. Naphthalin and salol may be tried, but generally are not well tolerated. Nitrate of silver, one-fortieth to one-twentieth of a grain every two or three hours, may be given for a week. Counter-irritants have a less happy effect than warm applications (moist or dry) and warm bathing. As may be judged from the remarks I made on laparotomy in connection with peritoneal tuberculosis, it cannot be recommended as a remedy until many more unbiassed observations shall have been gathered. In ascites paracentesis must not be performed unless urgently required, for many a case has been absorbed without any surgical interference.



# PARASITES OF THE INTESTINAL CANAL.

BY W. T. COUNCILMAN, M.D.

---

**History.**—Any study of the progress of our knowledge of the intestinal parasites shows that here, as in all other departments of medical literature, the same fluctuations of opinion prevailed as to the importance of the part which these parasites played and the frequency with which they were encountered. The development of our knowledge in this branch of medicine, as shown in the literature of the subject in the last one hundred and fifty years, is closely analogous to the development of our knowledge of the bacteria in the last twenty years.

There has always existed the desire to find some apparent cause to account for given phenomena, and, in the absence of any other known cause, the intestinal parasites, even some of the most harmless of them, were considered the cause of the most varied diseases. Dysentery, scurvy, hydrophobia, and even some of the most dangerous epidemics of the Middle Ages, were regarded as due to intestinal parasites. When these were not discovered, their existence was supposed. The discovery of the itch mite and the proof that this was the cause of that wide-spread disease gave importance to this belief.

Then, as was most natural, there came a reaction. The presence of the parasites was acknowledged, and it was believed that they were injurious, and could even endanger the life of their host, but their connection with any known form of disease was denied. Many, indeed, denied that they were attended with any danger to the individual, and some went so far as to argue that they exerted a beneficial effect, in that they assisted digestion by increasing the secretion of mucus and stimulating the peristaltic action of the intestine. These latter views were held by some of the most distinguished of the investigators, but many of the physicians held to the old ideas. To many, when they did not know anything of the real nature or cause of a disease, it served as a cloak for their ignorance to speak of worm-irritation, worm-fever, and worm-diseases in general. Others, while they did not deny that certain pathological conditions in the intestine were associated with the presence of worms, asserted that there was no causal connection between the two, and supposed that there could be certain pathological conditions which predisposed the intestinal canal to the pro-

duction of worms. Bremser, one of the most celebrated of the helminthologists of the time, designated under the name of diathesis verminosa a condition of the alimentary canal accompanied by disorders of nutrition and digestion in consequence of which material accumulated in the intestine which was favorable to the production of worms. It was even held by such distinguished investigators as Rilliet and Barthez that this worm-diathesis could exist without the presence of worms. It was only after exact scientific work by patient investigators, accompanied by experiments on animals and man, that the life-history of most of the intestinal parasites, and the part which they play in the production of disease, were put on a firm and scientific basis.

The subject of intestinal parasites has a further importance because the first proof of the connection of a typical infectious disease, trichinosis, with a living germ, the trichina spiralis, which in its adult life is an intestinal parasite, was acknowledged at a time when the causal connection of bacteria with disease was denied by very many, although the proof of it was just as definite and positive as that of the connection between trichinosis and the trichina.

**Pathology and Clinical History.**—The pathological conditions produced by the different intestinal parasites depend on the nature of the parasite and on the part of the intestinal canal which it inhabits. Thus, it is natural that the *anchylostoma duodenalis* should produce a set of symptoms different from those produced by the *ascaris lumbricoides*, and this, again, symptoms different from those produced by the *oxyuris vermicularis*.

In regard to the manner in which the parasites exert an influence on their host, we have principally three matters to consider. In the first place, they grow and exist at the expense of their host. They exert a local influence by their bulk, in that they make pressure on the parts around them and may close canals in which they live. Their presence and their movements may produce pain, and may variously affect the physiological functions of the intestine; they may also, by irritation of the sympathetic nervous system, give rise to symptoms of the most varied character. It is not known whether, like the bacteria, they produce certain chemical substances, ptomaines, which have an injurious action, but it is probable that they do so.

The first of these modes of action, the withdrawal of nutriment from the host, is generally of little or no importance, but under certain circumstances, and when the host is a delicate, badly-nourished child, this may amount to something. Leuckart estimated the weight of a *bothriocephalus latus* twenty-two feet long to be twenty-seven and a half grammes, and that in the course of the five or six months that it took to reach this length it probably consumed six or seven times its weight of food,—a quantity which is scarcely worth mentioning. When the parasites are present in great numbers, as sometimes happens in the case of lumbricoid worms, five hundred or more of which have been seen in a single case, estimating, as

Leuckart does, the yearly consumption of one at three grammes, it will be seen that so great a number as this must withdraw a considerable amount from the nutrition of the body. When the worms do not live on the intestinal contents of the host, but, attaching themselves to the mucous membrane, directly take the more valuable blood, the case is much more serious. Thus, the *anchylostoma duodenalis* produces the most severe forms of anæmia not only by the direct withdrawal of blood, but also by the subsequent hemorrhage from the bites which it makes.

The effects which the parasites produce acting by their bulk alone, as in closing the lumen of canals, are of little importance. The most serious of these are when the round worms, leaving the intestine, wander into the biliary or pancreatic ducts or into the air-passages. There may also be exceptional circumstances in which such masses of lumbricoids are present that their bulk may in some place fill the entire lumen of the intestine and produce strangulation.

The most important effect of the parasites is the irritation which they produce of the nerves of the intestinal canal. This is shown by various symptoms, some of which are referable to the intestine, but others apparently have not the slightest connection with it. All these nervous symptoms are more pronounced in children than in adults, because the nervous system in the former is so much more excitable than in the latter.

Many of the intestinal parasites pass through an embryonic condition in which the embryo lives under relations which are very different from those which suit the adult parasite. In some cases the real danger to the host is not connected with the presence of the adult animal, but with the embryo. Thus, the adult *trichina* in the intestinal canal produces symptoms which, though severe, are attended with no danger to life, but a dangerous and often fatal set of symptoms begins with the wandering of the embryos into the muscles.

**Modes of Infection.**—The results of the scientific study of the intestinal parasites have been particularly shown in the increased knowledge of the modes of infection, and the most valuable results in prophylaxis have been the outcome of this. Many of the parasites pass through different forms in the course of their development, and these different forms for the most part require different hosts. Nothing has been more clearly shown than that we derive many of our parasites from the domestic animals. Sometimes the parasite passes over to us in an embryonic form, sometimes in the form of eggs which find in our bodies suitable conditions either for complete development or for development up to a certain degree. Thus, we become infected with one variety of tape-worm from eating the embryos which appear in the hog in the form of small cystic animals in the muscles, and with another variety from eating beef in which a similar phase of embryonic development is found. Infection takes place from the use of animal food containing the embryos of the parasites, and also from introducing the eggs in various ways into the intestinal canal. Thus, it is not uncommon

to have vegetables fertilized by the use of liquid manure which may contain great numbers of the eggs of certain parasites which reach the intestines when the vegetables are eaten in the form of salads. There is not so much danger, or none at all, when the vegetables are cooked thoroughly. The drinking-water may also serve as a vehicle for infection. The eggs or embryos of parasites after being passed out with the feces find their way into the streams, being washed there by the rains, and in this way enter into the water-supply of cities. This mode of infection may be guarded against by filtering the water, for none of the eggs will pass through properly-constructed filters.

Another important mode in which the infection may be kept up is that by self-infection. The eggs of certain of the parasites are continually passing from the intestinal canal, generally in the feces, and in persons of uncleanly habits these eggs may get on the fingers and thus again be taken into the mouth, and develop in the intestinal canal. This is most common in the case of the small oxyuris worms. It is almost the rule to find the eggs beneath the finger-nails of persons afflicted with this parasite. The cysticercus cysts found in man result from swallowing tape-worm eggs, and frequently the eggs are derived from a tape-worm in the same individual.

It is natural that, so much depending on cleanliness and the proper preparation of the food, the intestinal parasites should be so much more common in those lands where the people live more in a state of nature and do not use so much care in the selection of their food. Thus, the echinococcus-cyst, produced by eating the eggs of the *tænia echinococcus*, a common parasite of the dog, is very common in Iceland, where the people live on intimate terms with the dogs. In Abyssinia, where the habit of eating raw beef is very prevalent, the *tænia mediocanellata*, the cystic embryo of which is found in beef, is very common. In all cases the eating of raw or underdone meat, and of vegetables in the form of salads, offers a much greater chance for infection than when the food is thoroughly cooked, since cooking destroys both the eggs of the parasite and the embryos. Many of the parasites are more common in children than in adults. This cannot be because the intestine of the child offers a better place for the growth of the parasite than that of the adult, but the chances of infection in the child are greater. The child has for itself no habits of personal cleanliness, and is not so careful as to what it puts into its mouth.

Certain lands are the homes of particular parasites. One of the varieties of tape-worm, the *bothriocephalus latus*, is found only in certain parts of Europe, and another variety only in Greenland. It can only be that the conditions for embryonic development are found here alone. Other parasites, though existing everywhere, are more common in certain lands. This may be due to the habits of the people, or to the eggs finding outside of the body more suitable conditions for development. Thus, the lumbricoid worms are more frequent in warm climates, because their eggs find in the heat and moisture the suitable conditions for reaching that

period of development which they must have before they can exist in the intestine.

**TAPE-WORMS.**—The tæniæ are long flat worms, composed of a number of segments which are slightly joined together. The segments are flat, and have some resemblance to pumpkin-seeds. The length of the worm may reach sixty feet, and the segments number many hundred. The head is round, and about the size of the head of a pin. Immediately behind the head the neck is at first narrowed and then increases in width. The neck has transverse constrictions, but the segments proper do not begin until some distance farther down. In each segment there are complete male and female organs. The genital openings are on the side of the segment, the male being directly over the female. These openings are on the alternate sides of adjoining segments. There are not usually more than three or four hundred sexually-mature segments in the worm. The constrictions in the neck become segments, the sexual parts gradually developing in them. The head of the worm is somewhat complicated, and the several varieties of tænia are distinguished from one another by the structure of the head and of the genital organs. The tænia solium, the pork tape-worm, has a slight projection at the apex of its head, and around this a series of chitinous hooks; below these are four powerful sucking disks. The tænia mediocanellata, the beef tape-worm, has a blunter head than the tænia solium and is without the circle of hooks. In both there is a system of water-canals which extend from the head through all the joints of the body. The tænia solium is nearly always found alone, whence its name. The French call it *ver solitaire*. Several of the tæniæ mediocanellatæ may be found in one individual.

The tænia solium is produced by eating pork which contains the embryos in the form of small cysts. These cysts represent the head of the worm and a single segment which is dilated to form a vesicle. The pork containing the cysts is known as measy pork. When such pork is eaten uncooked or insufficiently cooked, which often is the case with sausages, the head attaches itself to the mucous membrane and the worm continues to grow by the formation of segments. The eggs are not separated from the segments in the body, but the segments are discharged entire, either singly or in chains of several. They generally pass away with the fæces, but they may pass independently. Persons frequently have their attention called to the presence of the worm by finding these segments in the clothing. When the eggs are swallowed they undergo a partial development and reach certain parts of the body, where they become the cystocerci cellulosa. This development of the eggs may take place in man as well as in hogs. The embryonic form of the tænia mediocanellata is found in the beef, and the worm is produced by eating such flesh in a raw or underdone condition. Another variety of tape-worm found in man, the bothriocephalus latus, has a very limited geographical distribution, being found only in Russia, Sweden, Holland, Switzerland, and some parts of Germany. Little or

nothing is known about its development, but it is probable that it passes through an embryonic condition in certain fish and is produced by eating these. It is the largest of the tape-worms, having a length of from twenty to sixty feet, and the segments are an inch or more in breadth. The *tænia medicanellata* is more common in America, England, and France, owing to the fact that in these countries beef is often eaten not sufficiently cooked to destroy the embryos. In Germany the *tænia solium* is more common, because much pork is eaten either raw or imperfectly cooked in the form of sausages.

The tape-worm is never seen in nursing children where milk forms the exclusive diet. It is often met with from the age of five to fifteen years, and is most common from fifteen to forty. It is very curious that females are more subject to it than males, for there is nothing in the diet or the mode of life in the two sexes which can give any explanation of the fact. Warruch found in two hundred and six cases of tape-worm twenty-two in children. The relation of the sexes in the whole two hundred and six cases was seventy-one males to one hundred and thirty-five females.

**Symptomatology.**—In some cases the tape-worm produces no symptoms, and the host is made aware of the presence of his guest only by the passage of the segments. There are no symptoms which are absolutely diagnostic of the worm. Those which are generally enumerated may appear together or singly. There may be various disturbances of digestion, irregular appetite, unpleasant sensations in the belly, which in young children may increase to colicky pains and gastralgia. Reflex symptoms, convulsions, and even chorea and epilepsy, may appear, and are more frequently seen and more severe in children than in adults. Other disturbances referable to the nervous system are giddiness, buzzing in the ears, itching at the nose and anus, sometimes an increased secretion of saliva, nausea, especially when the stomach is empty, and even vomiting. Many patients complain of feeling the movements of the worm in the intestine, or of a sensation as of a ball being there. With all these symptoms the general health of the patient may remain perfect, but where there is much disturbance of digestion there may be a slight degree of wasting and pallor. Weak children suffer much more from the parasite than do those that are strong and well nourished. There may be various psychical disturbances: children are often fretful, peevish, and impatient. Often there is pain around the umbilicus, which radiates upward to the epigastric region. Sometimes this pain returns at regular intervals and is generally quieted by eating. The appetite is irregular: in some cases it is very poor, in others it is increased to regular boulimia. Sometimes the pain in the intestines is accompanied by a considerable degree of meteorism, and the swelling of the belly is very unpleasant. The reflex symptoms are said to be more common and more severe in cases of *bothriocephalus* than in either of the other varieties of tape-worm. In addition to the nervous symptoms mentioned, there may be nervous trembling, hysterical phenomena, a dry, convulsive cough, dis-

turbances of vision, hyperæsthesia or anæsthesia, disturbed sleep, crying and calling out in the sleep, etc.

**Diagnosis.**—There is nothing pathognomonic about these symptoms. A combination of neurotic symptoms, a tendency to colicky pains, and itching around the anus may lead one to suspect the presence of a tape-worm, but a certain diagnosis can be made only by evidence of the segments. When large masses of the worm have passed away, all the symptoms become much milder, and may even disappear for weeks or months. The entire worm, with the exception of the head and a small part of the neck, may be passed, and the symptoms disappear until a new growth of the worm takes place. A complete spontaneous recovery, with the passage of the entire worm, is very seldom seen. It is certain that the tape-worm, like all other living beings, must die after a time, but its duration of life is unknown, and in any case is a very long one. Cases have been known where the worm has existed for twenty years. After one has lived in the intestines for a very long time, all the symptoms occasioned by it become very much lighter or may even disappear altogether.

**Prognosis.**—The prognosis is always good so far as danger to life is concerned, but sometimes the tape-worm proves to be a guest that cannot be easily got rid of.

**Treatment.**—Care must be exercised in the use of remedies, especially in children, from the ease with which gastric disturbance may be set up. All tape-worm remedies, especially the most efficacious, have the disadvantage that they are liable to disturb the stomach. They should never be given on a venture, on a supposition from the symptoms that there may be a tape-worm present, but the diagnosis must be made certain by the presence of the segments. All these remedies act by killing the parasites, and some general rules for giving them may be found to be of advantage. In general it will be found more difficult to expel the worm in children than in adults, principally for the reason that the treatment directed against it in the former cannot be so heroic. One of the difficulties in the way of treatment is that the medicines are so unpleasant to take. It is better that a period of fasting should precede any attempt at therapeutics. This is supposed to weaken the parasite, and then the medicine will have a greater effect on the weakened animal. Often medicines seem more effective after large numbers of segments have been passed. A brisk purgation with castor oil should follow several hours after the anthelmintic has been given.

An old remedy against the worm is the bark of the pomegranate. Care should be taken to secure the fresh bark, as it soon loses its qualities when kept. The powdered bark should be macerated with an equal amount of water and this reduced by boiling to half the quantity. Very young children should be given half a teaspoonful of this decoction, and those over ten years old may be given a full teaspoonful. In order to prevent vomiting, a little of the syrup of orange-peel or ginger may be added.

The root of the male fern, *filix mas*, is a remedy which is much regarded.

It may be given in the form of a powder, the dose being from ten to ninety grains according to the age of the patient, either in a single dose or in divided doses. In general, better results follow the administration of one large dose than of several smaller doses.

Kousso is a remedy that of late years has been used with great success in the treatment of tape-worm, having been introduced into Europe from Abyssinia, where the disease is very common. It is a remedy which has some disadvantages, particularly with children, as it is very disagreeable to the taste and is apt to produce nausea and vomiting. An infusion is made of the flowers of the plant. Two to six drachms of the powdered leaves should be added to five or six ounces of boiling water, and, after cooling, the whole should be taken in divided doses, being careful to shake the mixture before taking. If no stool follows in three or four hours, a purgative should be given. A useful form of administration has been found in tablets made of the compressed leaves.

Pumpkin-seed is a useful remedy and one not disagreeable to take. The hull should be taken from the seeds, and the pulp rubbed with water to a thick mass, and of this from one to two ounces may be given in a single dose, and in a few hours followed by a dose of castor oil. Should the worm not be expelled, the dose may be repeated several times and a thorough trial given the remedy, for it is not disagreeable to the taste and produces no unpleasant symptoms.

Turpentine may prove effective when all other remedies fail ; it is better to give it in as large a dose as can be borne than in divided doses. It may be given in emulsion with milk or in capsules.

There are various other remedies which are used, but none will be found so effective as those mentioned.

Very often when the worm is passed the head will not be found. It may easily escape observation, or the worm may break off shortly behind the head, leaving this *in situ*. It seems to make no material difference whether the head comes away or not, since the worm dies when separation takes place shortly behind this. Sometimes a large portion of the worm follows the administration of remedies, but a considerable mass is left. There then results an abatement of all the symptoms for two or three months, but they will return with a further growth of the parasite. The worm may be expelled *in toto* as a rolled-up mass, or in several sections.

ASCARIDES.—The *ascaris lumbricoides* is the most common parasite in children, and, next to the *trichocephalus dispar*, the most harmless. It is a long, cylindrical, yellowish or reddish-yellow worm, pointed at both extremities. The body is marked by four longitudinal dark bands and is striated transversely. At the head are three rounded elevations, and between these a number of fine teeth. The male is easily distinguished from the female ; it is smaller, the posterior extremity much thinner, and always curved or rolled upon itself, while the female is straight. The length of the male is from four to seven inches, and of the female from six to eleven.



The vulva is in the middle line of the body, and nearer the head than the tail. The eggs are oval in shape, 0.075 mm. long and 0.058 mm. wide; when first passed they are almost transparent, but soon become yellowish and opaque. They undergo no development within the intestine, but pass out with the feces in great numbers. Much time is apparently required for their development, which takes place only under suitable conditions of warmth and moisture. The eggs are very indestructible, and may remain years undeveloped and then develop as soon as they are placed in favorable circumstances. The worms are much more frequent in children than in adults, and more frequent in females than in males. The embryo, still enclosed in the egg-membrane, is taken into the body in the drinking-water and in various other ways.

The essential habitat of the worm is in the small intestine, but it may wander throughout the intestine. It may pass through the rectum either with or without the feces, or it may take an upward course and be found in the stomach, cesophagus, or nose. Cases have not infrequently been seen where it has entered the air-passages, producing death either instantly from suffocation or later from gangrene of the lung. It may also pass from the intestine into the biliary or pancreatic ducts.

**Symptomatology.**—The most varied symptoms are given as due to the presence of these worms. Here, as in the case of tape-worm, the only reliable information is found in the presence of either the worms themselves or their ova in the stools. It is certainly true that in most children, even when the worms are present in considerable numbers, no symptoms are produced. In other cases, generally depending on the number of worms, certain vague symptoms are caused. There may be vague and unpleasant sensations in the umbilical region, which may increase to colicky pains. Sometimes there is more or less dull continuous pain, which at times becomes more severe. The abdomen is often swollen, the appetite is capricious, and there may be nausea and vomiting. Mucous diarrhœa is sometimes present. Many of the symptoms which are much regarded by the laity, such as itching and picking at the nose, are of no importance. Children who are weakly and in whom the worms are present in great numbers may lose flesh and become pale. There are various nervous symptoms, such as grinding of the teeth, unquiet sleep, disturbance of sensation, widening of the pupils, reflex convulsions, etc., but these are most common in very young children. There have been cases reported where obstinate epileptiform hysterical convulsions similar to chorea, aphonia, disturbances of sensation, etc., have ceased after the expulsion of a number of the worms.

In the tropics not only are the worms more frequent, but the symptoms produced by them are more severe. This is due to the enormous numbers of them which are sometimes present.

It is probable that the presence of the worms may aggravate any intestinal affection, but they seem to produce absolutely no effect on the healthy mucous membrane. For a long time it was supposed that the worms could

penetrate the intestine and enter the peritoneal cavity, or even wander elsewhere in the body. The evidence of this was sought in the presence of the worms in abscesses about the abdomen, and in the peritoneal cavity, either with or without peritonitis. It may be regarded as certain that they cannot pass through the intact intestinal wall, for their structure precludes this. The abscesses in which they have been found were in the inguinal or umbilical region, the most common places for hernia, and it is probable that these were produced by the parasite entering an inguinal or umbilical hernia and by its presence and movement in this confined place causing perforation with abscess-formation. When they are found in the peritoneal cavity, with peritonitis, they may have escaped through some small and easily-overlooked opening in the intestine, or in other cases some other parasite may have been mistaken for the ascaris.

It is always serious when the worm ascends the intestine to the pharynx and enters the larynx. It produces severe paroxysms of coughing, a feeling of suffocation, pain in the region of the larynx, and frequently a quickly-fatal asphyxia. If it passes the larynx and enters the trachea the symptoms become milder. There are still violent cough, hoarseness or even aphonia, pain in the breast, vomiting, and convulsions. If it is not expelled by the fits of coughing, death takes place in from one to three days, generally from gangrene of the lungs. It is a not very uncommon thing at autopsies to find a worm in the pharynx or the larynx, it having crawled there after the death of the individual.

**Diagnosis.**—As we have said, there are no symptoms which are in any degree positive. We may suspect the presence of the worms from a group of symptoms, but the diagnosis must always be made from finding the worms or the eggs in the feces. The eggs are often present in extraordinary numbers, and can be easily recognized. In a piece of feces no larger than a grain of wheat Davaine found from three hundred and twenty to three thousand eggs. In this case twenty-two worms were expelled after the administration of santonin, and thirteen of the twenty-two were females. The eggs of the lumbricoid can easily be distinguished from the long-pointed eggs of the oxyuris vermicularis and from the round eggs of the tenia. In looking for the eggs it is best to give a purgative, then filter the liquid stools and examine the solid residue microscopically.

**Prognosis.**—The prognosis is favorable. Unless the parasites are in enormous numbers they do not produce any dangerous conditions; but there is always some danger that they may wander into some other part and produce suffocation by entering the air-passages, or set up a purulent hepatitis by entering the bile-duct.

**Treatment.**—The remedy on which the most reliance can be placed is santonin, and this has the further advantage of being almost devoid of taste and smell. It may be given mixed with a little sugar in doses of from one-fourth to one grain. Sometimes it may be given mixed with a little calomel, and should then be followed by a purgative. The worms generally

begin to come away on the second day, and they may continue to pass for several days longer. As long as the worms continue to pass, the treatment should be continued; but the single dose should not exceed one grain.

**PIN-WORMS.**—The oxyuris vermicularis, commonly known as the seat-or pin-worm, though not so common as the ascaris lumbricoides, produces much more unpleasant symptoms. The male is much smaller than the female, and has the tail rolled into a spiral. The length of the male is from one-twelfth to one-sixth of an inch, that of the female from one-fourth to one-half of an inch. In both sexes the body presents a more or less fusiform shape, the anterior end being rounded to form a somewhat abruptly truncated head, which is rendered very conspicuous by a bulging of the transparent integument around the mouth, which presents in profile the appearance of winged appendages. The integument is transversely striated and of silvery whiteness.

The eggs are smooth, oval, 0.053 mm. in their long diameter and 0.028 mm. in their short; they undergo segmentation while in the intestine, and when discharged a tadpole-like body is often found within them. When they are placed in warm water this tadpole-like embryo soon changes into a long slender worm and leaves the egg.

The whole course of development takes place in the intestine. As soon as the worm is freed from the egg it wanders into the upper part of the intestine. Here it grows quickly, the sexes become differentiated, and after this it descends again into the lower portion of the small intestine, where conception is effected. The females then enter the cæcum accompanied by the males, and here and in the large intestine complete development takes place. The eggs are deposited in the rectum, partly in the mucus and partly on the mucous membrane. The development of the worm is very rapid. Leuckart and three of his scholars swallowed the eggs, and found the young embryos in the stools fifteen days afterwards.

The worms are also propagated by self-infection. They get on the fingers or beneath the nails, from the efforts which the patient makes to allay the intolerable itching in the neighborhood of the anus, and are conveyed in this manner into the mouth. Cobbold mentions the case of a person afflicted with myriads of these entozoa who in his distress and rage was accustomed to catch the worms and bite them in two. As he did not select the male worms for this pleasant operation, he exposed himself to a terrible revenge, for no surer way could be found to introduce the eggs into the intestinal canal. It will readily be seen that this method of self-infection must play a greater rôle in children than in adults, owing to the fact that their habits are less cleanly.

The worms may exist in large numbers, and their capacity for increase is very great. On this account the disease is often very obstinate: although great numbers may be expelled, their place is quickly supplied if any worms remain.

**Symptomatology.**—They may be present in considerable numbers

without producing any symptoms. Ordinarily they produce a chronic irritation of the rectum, with itching, burning, and pain which extend to the external genitals. In the evening and at night, especially after the patient has become warm in bed, the worms seem to be in their most excitable condition and give rise to various unpleasant symptoms. Frequently the symptoms return every night with the utmost regularity. In children, especially, various sympathetic nervous phenomena may be added, such as restlessness, itching of the nose, involuntary twitchings, grinding of the teeth during sleep, chorea, convulsions, and even epileptiform seizures. The itching and burning of the genitals may lead in both sexes to onanism. In young female children pruritus and leucorrhœa are sometimes seen, and in those approaching the age of puberty, various forms of hysteria. There is often a marked anæmia, but instead of anorexia there may be a ravenous appetite, especially in children. Diarrhœa is sometimes present, but there may be considerable constipation. If the condition has lasted a long time the stools are rather soft, of a very fetid odor, and mixed with mucus. Not only do the worms pass out in the stools, but they also creep out spontaneously, and an investigation of the anal region will often reveal them in the folds around the anus. In female children they may enter the vagina and here set up a purulent inflammation. Within the anus the mucous membrane is swollen, deeply injected, and covered with mucus, which is often tinged with blood.

**Diagnosis.**—The diagnosis is generally easy to make. On inspection of the anal region the worms will often be seen, though they are so small that they can easily elude observation. By washing out the rectum with cold water and examining this they may always be found if present. The eggs may be recognized on microscopical examination by their long-oval form. There are various conditions other than the worms which can produce the local symptoms, and the only certain basis for diagnosis here, as in the case of other worms, is the presence of the worms or their eggs.

**Prognosis.**—There are no really dangerous conditions produced by the oxyuris, but the condition is unpleasant and often very difficult to treat successfully. They may apparently all be driven out, but if a few remain in the folds around the anus these will serve as new foci for further infection.

**Treatment.**—In this disease, which is so obstinate and which often returns after apparent cure, it is necessary not only to treat promptly, but also to continue the treatment for some time. The chief reliance in the treatment has been wrongly placed on injections which have for their purpose the destruction of the worms in the rectum. Although the unpleasant symptoms which we have described are almost entirely due to the presence of the worms in the rectum, it must not be forgotten that the worms here are constantly being added to from the small intestine. It is best to add internal medication to the rectal injections, and thus attack the worms from above and below. The internal treatment is the same as that for the lum-

bricoid worms. Various ointments may be rubbed into and around the anus to destroy the worms which are in the folds. Rectal injections, either of cold water alone or of a weak solution of quinine, may be used with good effect. Injections of a solution of corrosive sublimate, one to one thousand, have been recommended. The treatment should be continued at intervals for several weeks, until both the worms and the eggs have disappeared from the stools. During the treatment care should be taken that the digestion is not impaired. The necessity for the utmost care in the treatment will become apparent when it is borne in mind that the disease in adults and old people sometimes seems incurable.

**TRICHOCEPHALUS.**—Another parasite which is exceedingly common, but whose presence in the intestine produces few or no symptoms, is the trichocephalus dispar. The peculiarity of this parasite consists in the anterior part of the body being exceedingly thin while the posterior part is thicker. The male is shorter than the female. The length of the male worm is from one and one-fourth to one and a half inches, while that of the female is two inches. The eggs are oval, and somewhat resemble those of the oxyuris, but are not so sharp-pointed. The habitat of the parasite is in the cæcum, and it is seldom found in any other part of the intestinal canal. When great numbers of them are present they may produce some irritation.

**TRICHINÆ.**—The most dangerous of the worm-parasites are the trichinæ, but the real danger with them is not connected with the presence of the adult worm in the intestinal canal, but with the embryonic condition in which the parasites invade the voluntary muscles. The embryos are frequent in the muscles of pigs, and from eating flesh containing them, in an imperfectly-cooked or a raw condition, infection takes place in man. They may also be found in other animals,—in rats, cats, mice, moles, and some others. The infection of the pig results principally from eating the flesh of infected rats and mice. The embryo worms are coiled up in the muscular fibre, and are  $\frac{1}{28}$  of an inch long and  $\frac{1}{620}$  of an inch broad. When introduced into the stomach they increase in size and become sexually mature in two or three days. They produce viviparously an astonishing number of young, estimated by various authors at from two hundred to one thousand. These penetrate the mucous membrane, and in a short time find their way to the different muscles of the body.

**Symptomatology.**—The presence of the sexually-mature trichinæ in the intestine produces a more or less intense gastro-intestinal catarrh: even small ulcers and erosions in the duodenum may be caused by them. Secondly the mesenteric glands are swollen and hyperæmic. When the embryos first enter the muscles they cause the most exquisite myositis, with a great deal of small-cell infiltration. They then enter the single muscular fibres, roll up into a spiral, and become surrounded by a capsule, which is at first soft, then calcified.

The symptoms are divided into two groups,—those caused by the worms in the intestinal canal, and those caused by the invasion of the muscles.

Those in the intestine are due principally to the perforations of the wall. When it is considered that the number of these perforations may reach into the millions, it can easily be seen that notable disturbances may be produced. These are shown by diarrhoea, abdominal pains, and vomiting. There are usually loss of appetite, general malaise, weakness, headache, and unquiet sleep. The secondary symptoms relate to the muscles. The chief symptoms are intense pain and inability to move. Constitutional symptoms accompany both conditions, and often simulate those of typhoid fever. Œdema of the face or of the lower extremities is often seen. Death takes place from exhaustion, and is often preceded by coma.

**Prognosis.**—The prognosis depends almost entirely on the number of embryos which are generated in the intestinal canal. When a great number are present, the disease is almost necessarily fatal. If not fatal, the symptoms slowly subside, the worms in the muscles become encysted, and thenceforth they are quiescent.

**Treatment.**—The only time when treatment is of any efficacy is when the mature worms are in the intestinal canal. Then purgatives and anthelmintics are indicated. In the very beginning of the attack emetics may do good. Afterwards, in spite of the diarrhoea, purgatives should be freely given. Calomel in rather large doses should be given every three or four days, followed by full doses of castor oil. Injections of corrosive sublimate, one to two thousand, may also be given. Benzine, given both by the mouth and as a rectal injection, has been recommended. After the worms have left the intestine no medication directed to their destruction is of any avail, and the general condition alone can be treated.

The prevention of the disease is as easy as its cure is difficult. Thorough cooking of the meat, by which all parts of it are raised to the boiling-point, is all that is required. Other modes of preparation of the meat, such as prolonged smoking, pickling, etc., have no effect on the parasites.

# HERNIA IN CHILDREN.

BY WILLIAM J. TAYLOR, M.D.

---

HERNIA in children may be either *congenital* or *acquired*. Of congenital hernia we have *inguinal*, the most common; *umbilical*, rarely seen in later childhood; and *diaphragmatic*. Acquired herniæ are not common: they may be either *femoral*, which is never congenital; *inguinal*; or through the *linea alba*, not truly umbilical.

A hernia is a protrusion of a portion or the whole of a viscus through the walls of the cavity in which it is contained. The term is generally used to designate a protrusion of the abdominal contents through one or more of the natural openings. These protrusions or herniæ are named, according to their position, *umbilical*, *inguinal*, *femoral*, etc.

The cause of hernia in the umbilical and inguinal varieties, with which we have most to do, is an arrest of development in the fœtus. The inguinal variety is due to a delay in the descent of the testicle and to the incomplete formation of the transversalis, internal oblique, and cremaster muscles. At the umbilicus the closure of the opening is delayed by the omphalo-mesenteric vessels which emerge here.

The crying of the new-born child and distention of the intestine from food improperly digested may force out a portion of the bowel through one or other of these imperfectly-closed openings. A weakened condition of the inguinal and umbilical rings may persist for months and even years, and it is not until some special effort is made, as in crying, straining, or vomiting, that the weakened ring dilates and a hernial protrusion occurs.

The femoral variety is extremely rare before puberty, and is never congenital, but always acquired. In a case reported by Mr. Thomas Bryant<sup>1</sup> it showed itself first after violent jumping in a girl aged nine years whose muscles were all much relaxed from poor health.

There are certain general signs common to all herniæ. More or less suddenly, near some one or more of the natural openings there will appear a tumor, which increases in size on muscular effort or straining and gives an impulse to the finger on coughing. It generally disappears on lying down. The tumor, if of intestine, will be elastic, and, when firmly grasped

---

<sup>1</sup> Medical Times and Gazette, 1862, vol. i. p. 136.

and manipulated or reduced, a gurgling, due to the gases in the interior of the intestine, may be noticed.

Herniæ in children nearly always consist of intestine, and in extreme cases the greater part of the bowels may be so displaced. The omentum is so poorly developed that it forms little or no part in such ruptures. By gentle manipulation this tumor can be replaced within the abdominal cavity. Of course if there be strangulation this cannot be done.

Herniæ may be single, double, or multiple.

#### CONGENITAL UMBILICAL HERNIA.

In early foetal life the abdominal cavity is open in front, and is closed by a gradual development of the abdominal plates. The last point to close is the umbilicus, where the omphalo-mesenteric and allantoid vessels pass. Sometimes, as in other parts of the body (*e.g.*, spina bifida, hare-lip, and similar deformities), the two sides coalesce normally except at the final point of closure, where the process is arrested. If this is at the umbilicus it is left patent, and readily affords exit to the abdominal contents.

Dr. James R. Chadwick, of Boston,<sup>1</sup> suggests a second factor. The intestines are developed outside of the abdomen. If the volume of the intestines be too great to be easily enclosed by the undersized abdominal walls at a time when the latter should be normally closed, intra-abdominal pressure will prevent the retreat within the abdominal cavity of certain portions of the intestines which have until that time lain normally in the umbilical cord. When the umbilical vesicle and its duct with their vessels fail to atrophy in the process of embryonic growth and persist to a later period than usual, they act as a cord anchoring that portion of the intestine with which they are connected, outside of the umbilical ring, thus producing the hernia. This latter condition may occur without there being any deficiency in the development of the abdominal plates. He demonstrates this by some dissections.

A case reported by Dr. T. R. Ronaldson<sup>2</sup> seems to confirm Chadwick's view. In this case, at birth, a child was found to have a tube of skin, from two to three inches long and two inches in diameter, projecting downward and forward from the region of the navel. At the end of the tube, and below, sprang the umbilical cord. The end of the tube consisted mainly of a unilateral bulging in the umbilical cord. On the upper surface was a tumor the size of a large apple. The covering of the tumor was composed simply of amnion; the contents consisted of a portion of the liver and numerous coils of intestine, which could be plainly seen through the transparent peritoneal and amniotic covering. An operation was performed, and the child recovered.

---

<sup>1</sup> Rare Forms of Umbilical Hernia in the Fœtus, Transactions of the American Gynecological Society, 1876, p. 364.

<sup>2</sup> Edinburgh Obstetrical Society Reports, 1882-3, viii. 1017.



Dr. J. M. Barton<sup>1</sup> reports the case of a female child who at birth had an umbilical tumor two and a half inches high, over three inches in diameter, and slightly pedunculated. It was composed of omentum and intestine, which protruded through an opening in the abdominal wall more than two inches in diameter, and was covered by a thin layer of the expanded gelatinous matter of the umbilical cord; this was as transparent as glass. The intestine and omentum could be distinctly seen through it, and after the return of the tumor into the abdominal cavity the left lobe of the liver could be easily recognized. The cord joined the tumor about half an inch to the left of its apex, and the vessels of the cord could be traced down the left side of the tumor and entering the abdominal cavity. He operated when the child was thirty-three hours old, as the parents would not until then consent. The gelatinous covering readily broke down under the fingers and was very offensive; this was dissected away. The bowels were found to be highly inflamed; over half an ounce of opaque serum, with flakes of lymph floating in it, ran out from the abdominal cavity. The edges of the opening, measuring six and a quarter inches in circumference, were freshened and brought together with hare-lip pins, leaving an inch of the wound ununited for drainage, through which passed the umbilical vessels. The child made a good recovery.

The umbilical aperture, always open at birth, but usually closing soon after the ligation of the umbilical cord, may persist for weeks, and is covered with skin, superficial fascia, and peritoneum. A coil of intestine may readily push itself out, and it has even protruded so far as to be included in the ligature of the cord.

During the whole of the first year of life the *linea alba* is weak, and sudden efforts of violent coughing, straining, or crying may push a coil of intestine through some point which is weakest. This is not truly an umbilical hernia, as a rule, and is generally above the umbilicus. Holmes<sup>2</sup> calls it a "hernia through the *linea alba*." He likewise says he has never known of such a hernial protrusion between the umbilicus and the pubes.

**Diagnosis.**—The diagnosis of this condition is unmistakable. The position and character of the tumor, its elastic feel, the ease with which it can be returned within the abdominal cavity, the increased bulk and tension on crying or straining,—all these make the diagnosis easy. It is to be distinguished from dropsy of the funis, malignant tumors of the umbilicus, and cysts; but the differential diagnosis is so clear that it need not be elaborated.

**Prognosis and Treatment.**—The prognosis is always good. Even if let alone, congenital umbilical herniæ nearly always get well of themselves, for this condition persisting in late childhood is very rare. Much, however, can be done by properly-directed treatment to hasten and aid nature in her efforts at cure.

Generally a simple binder, or, better still, a disk of bone or metal from one to one and a half inches in diameter, covered with soft linen, placed over the umbilical opening and fastened there with adhesive plaster, will be sufficient. The old practice of putting a ball or a conical pad over the ring is a great mistake, as, by pressing into and dilating the ring, the very object for which the binder is applied is defeated.

---

<sup>1</sup> Medical News, August 3, 1889, p. 137.

<sup>2</sup> Surgical Treatment of Children's Diseases, p. 560.

The instrument-makers now sell a most useful apparatus made of india-rubber. It consists of a band with eyelet-holes at the ends, through which a string can be run to permit of lacing lightly to the body. In the centre of this band, which is some two inches wide, is a little bag to which is attached a bit of rubber tubing. This when inflated makes a cushion about an inch and three-quarters in diameter, and covers over but does not press into the open umbilical ring.

Occasionally all efforts by these simple measures are insufficient, and then a truss with a flat pad and a light spring must be used. Mr. John Wood<sup>1</sup> recommends a pad consisting of a ring over which is stretched a thick rubber diaphragm, as best for the purpose. Great care on the part of the child's nurse is needed in keeping the gut retained by the fingers whenever the binder or truss is removed, as it should be at least twice a day for purposes of cleanliness. For every time the gut comes down the ring is dilated and its closure retarded. Too great stress cannot be laid upon the importance of this care on the part of the nurse to prevent the hernia from re-appearing even once, and also upon extreme cleanliness. The parts should be dusted with some simple powder every time the truss is removed, to preserve the skin from irritation.

It is also of great importance that digestion be properly performed, and no undue amount of gaseous distention of the intestines permitted, which by internal pressure might defeat our object.

Sometimes all our efforts are of no avail in retaining the gut in place, and a question of operative interference then presents itself. Nature will do much in this condition if left to herself, but still more if intelligent aid be given,—as is shown by the fact that this condition is almost never seen in late childhood. Persistent efforts, first with one and then another binder or truss, should be made before any more radical measure is attempted. Sometimes it may be necessary to keep the child lying on its back day and night, gravity thus aiding the binder or truss.

Mr. Holmes considers the best and safest method of radical cure to be a subcutaneous silver ligature introduced around the umbilical ring and including in it the pillars of the ring, the ligature cut off and allowed to remain. Acquired herniæ should be treated in the same general way as the congenital.

A case is reported by Dr. Phenomenon<sup>2</sup> of successful laparotomy for umbilical hernia in a child but one hour old. The child was born with a large umbilical hernia, and, within an hour after the ligation of the cord, was placed under the influence of chloroform and operated upon. The sac, peritoneum, and wound were sutured, the abdominal cavity was sterilized, and the child made a rapid and uncomplicated recovery.

It would seem, in view of this case, which is remarkable, and of other

---

<sup>1</sup> International Encyclopædia of Surgery, p. 208, 2d ed.

<sup>2</sup> Revue Gén. de Clin. et de Théor., July 11, 1889.

laparotomies for umbilical hernia in children, that we should be justified, in cases of great persistency, in opening the belly, freshening the edges of the umbilical ring, and closing it with sutures. Such an operation should be done under the strictest aseptic precautions.

#### CONGENITAL INGUINAL HERNIA.

This occurs in both sexes. While very common in girls, it is in them simply the passage of the gut down a patulous canal of Nuck, and need cause little uneasiness as to final cure unless there is associated a hernia of the ovary, when the matter assumes a more serious aspect. When an ovary has made its way down this patulous canal of Nuck, as it sometimes does, it should be reduced and returned within the abdominal cavity by taxis; or, if this is not possible, an operation must be done, the canal opened, and the ovary returned within the abdomen or removed, as may be found best. The treatment for such hernia in girls when the ovary is not in the hernia is the same as for hernia in boys.

Mr. Bilton Pollard<sup>1</sup> reports the case of a female child aged three months, who was admitted into the Northeastern Hospital for Children under his care. One month before this the child's mother first noticed a lump in its right groin, which would at times vary in size or disappear. A truss was applied March 19, 1889, and the hernia was supposed to have been reduced. On the 27th the truss was removed, and an irreducible swelling was noticed in the right groin. The child was admitted into the hospital on the 30th. There had been some vomiting, but her bowels had moved on the morning of the 30th, and a swelling rather larger than a pigeon's egg was situated over the right external abdominal ring, and distended the upper part of the right labium majus. The skin over it was red and hot; the swelling felt elastic, and distinct fluctuation could be made out; it was irreducible, gave a dull note on percussion, and altogether simulated an abscess.

The child was placed under the influence of chloroform. The superficial tissues were œdematous and matted together. The sac was opened, giving escape to some turbid blood-stained fluid. It contained an ovary and the fimbriated extremity of the Fallopian tube; they were both greatly swollen, black or gray in color, and in places coated with lymph. The pedicle was drawn down, transfixed, and tied with silk ligatures, and the ovary and tube were removed. The child made a complete recovery, and was discharged from the hospital, cured, on the eighteenth day from the operation.

Inguinal hernia in boys is of serious moment, and, although all congenital herniæ have a tendency to natural cure, unless care be exercised in the management much trouble may result.

In the fœtus in utero the testicles are in the lumbar region, behind and partly invested by the peritoneum. As the testicle descends, which usually occurs shortly before birth, but may not take place until some time thereafter, it is accompanied by a prolongation of this serous membrane down into the scrotum. This forms the vaginal or funicular process of the peritoneum. It lies in front of the testicle and spermatic cord, and extends from the internal abdominal or inguinal ring to the lowest part of the testicle, where it forms a cul-de-sac.

---

<sup>1</sup> Lancet, 1889, ii. 165.

Normally this process of the peritoneum contracts a little above the head of the epididymis and finally forms two cavities,—the superior, now called the *tunica vaginalis propria funiculi*, lying in front of the spermatic cord, and the inferior, or *tunica vaginalis propria testis*, which lies in front of the testis and lower part of the cord. The inferior cavity thus becomes and remains a closed serous sac. The superior cavity usually is obliterated by adhesion of its walls, the upper, funnel-shaped end being the “infundibular fascia” at the internal ring.

In the majority of infants some portion of the upper part of this process of the peritoneum remains open at birth, and any effort, such as crying, coughing, or straining at stool, may press a small bit of gut into the abdominal opening. As it has a ready-made serous-lined sac, it pushes down still farther, and, if the closure at the head of the epididymis has not occurred, it finds its way down into the scrotum, in front of the spermatic cord and testes. This is what is known as the *hernia congenita* of Haller (Fig. 1).

FIG. 1.

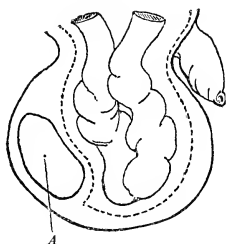

CONGENITAL HERNIA.—A, testicle.

FIG. 2.

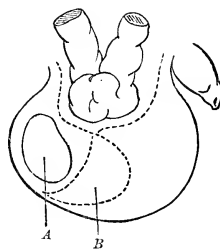

FUNICULAR HERNIA.—A, testicle; B, tunica vaginalis testis.

It is that form which is most frequently met with, and may be found either at birth or not until weeks or months thereafter.

FIG. 3.

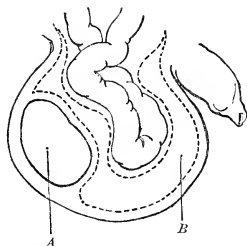

ENCYSTED HERNIA.—A, testicle; B, tunica vaginalis testis.

In *funicular hernia* the adhesion has formed just above the testicle, and the bowel extends only into the vaginal process of the peritoneum in front of the cord, and does not pass down into the tunica vaginalis testis (Fig. 2). With it may be associated a congenital hydrocele. In that case the hydrocele is developed in the closed inferior sac in front of the testicle as usual, and the bowel extends only a short distance down the funicular process.

In *infantile* or *encysted hernia* the tubular process has been obliterated at the internal abdominal opening or ring, while the closing process above the testicle has not taken place (Fig. 3). In the efforts of crying or coughing a loop of intestine is forced down, carrying a special

prolongation of the parietal peritoneum with it, which forms a sac; this is forced down into the funicular process or tunica vaginalis. This form of hernia can be recognized only upon operating.

Mr. Edmond Owen<sup>1</sup> describes yet another variety, in which, the funicular process being closed at the abdominal ring but open into the tunica vaginalis testis, a bit of gut in a special sac is driven down into the scrotum behind the funicular process and tunica vaginalis (Fig. 4). In operating for this condition three layers of peritoneum must be cut through before the contents of the hernial sac are exposed.

An inherited predisposition to hernia is very common, equally so in both sexes, and is manifested in the most marked degree in infants under twelve months of age. Mr. Kingdon,<sup>2</sup> in speaking of this hereditary predisposition, says that fathers who themselves had hernia in infancy but who have grown out of the affection beget children with congenital hernia, who also grow out of it. Brothers sometimes become ruptured about the same age, and before their father. He states that it is not uncommon for children to be brought to the City of London Truss Society with herniæ in whom no family tendency can at the time be traced, but at their next visit, a year or so later, it will be said, in answer to the customary questions, that the father became the subject of hernia in the interim.

Race has also much to do in this affection. Lascars seldom have hernia; it is not so frequent among the Irish as among the Germans and English; and the Jews are very prone to rupture. An abnormally long mesentery is generally considered to be an important factor in the causation of hernia. If this is so, it is hard to explain why congenital herniæ are so extremely rare among monkeys. Mr. J. Hutchinson, Jr., in the course of some remarks made at a meeting of the Pathological Society of London, November 15, 1887,<sup>3</sup> stated that he had never met with a hernia in a monkey, a long mesentery, however, being very common. Mr. Bland Sutton, at the same meeting, said that in a dissection of over eight hundred monkeys he had found only two congenital herniæ; and if a patulous funicular process predisposes to hernia this should be common, for, with the exception of the gorilla and some of the chimpanzees, man is the only animal in which the funicular process becomes normally obliterated above the testes.

*Sex.*—Mr. Birkett<sup>4</sup> remarks that, “after carefully considering the state-

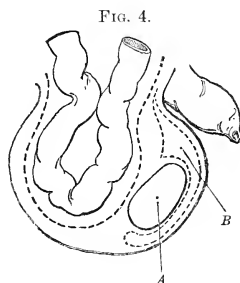

FIG. 4.  
FUNICULAR HERNIA, WHERE THE PROCESS HAS CLOSED AT THE ABDOMINAL RING.—A, testicle; B, tunica vaginalis testis.

<sup>1</sup> Surgical Diseases of Children.

<sup>2</sup> Med.-Chir. Soc. Trans., 1864, p. 311.

<sup>3</sup> British Medical Journal, 1887, ii. 1102.

<sup>4</sup> Holmes's System of Surgery, Amer. ed., 1881, p. 666.

ments of writers in relation to the numerical proportion in which the two sexes are subject to hernia, we must admit that we have not the requisite data to enable us to arrive at any satisfactory conclusion." He gives Mr. Kingdon's estimate from the statistics of the City of London Truss Society, covering a gross total of 96,886 applications for trusses, the proportion being two males to one female, taking all ages and including every variety of hernia. He shows, by these statistics for 1860 and 1861, that of children under five years of age there were 1409 males as against only 107 females.

Dr. Edward Swasey<sup>1</sup> states that it is a matter of statistics as well as of common observation at the Hospital for Ruptured and Crippled that female children are more prone to suffer with umbilical hernia than male. Just why this should be he can give no satisfactory explanation, but he suggests the proportionately larger funis in the female as a factor. Certain it is that in the adult female the navel is a wider and deeper depression than in the adult male. The fact is so marked that it was noticed even by the ancient artists, as may be seen on comparing the Venus de Milo or the Venus de' Medici with any antique male statue. The admitted frequency of inguinal hernia on the right side in comparison with that of the left is attributed by Swasey to the weight of the liver pushing downward and forcing the intestine into the open funicular process.

**Treatment.**—In young children the digestion must be carefully looked to. Vomiting from overfeeding or improper food; constipation or diarrhoea, with straining at stool; a persistent cough from bronchitis or elongated uvula, or chronic pharyngitis,—these must all be remedied. Then, also, nasal obstruction from growths or a chronic catarrh must be relieved. Likewise the constriction of a contracted and adherent prepuce must be overcome, as the straining thus caused may produce a rupture. All these causes operate to prevent nature in her efforts at repair, and by their persistence hinder or may even completely destroy all chances of cure directed solely to the hernial protrusion.

In infants and young children a truss applied to the inguinal region is often retained in place with great difficulty, and, unless the rupture be of unusual size, a very simple home-made apparatus, fully described by Mr. Walter Pye,<sup>2</sup> may conveniently be substituted (Fig. 5). This consists of a skein of Berlin wool—or, for very young infants with sensitive skin, of lamb's wool—made to encircle the pelvis. One end is passed through the loop of the other at a point corresponding to the inguinal ring, and may be fastened there by a thread; the free end is then carried between the thighs and is fastened behind to the portion which forms the girdle. About thirty threads are generally sufficient. This may be worn during the morning

---

<sup>1</sup> *Hernia in Children*, based on a Study of Five Hundred Cases under Personal Observation, *Amer. Jour. of Obstet.*, July, 1880, vol. xiii. No. 3.

<sup>2</sup> *British Medical Journal*, 1887, i. 1152.

and evening bath, when a fresh, clean one can be applied. With ordinary care the skin does not become irritated, and, as the expense of such a truss is very little, since it may be washed repeatedly, it is within the reach of even the poorest. No pad is used, the bulk of the loop with the strands passed through it being sufficient. I have had a personal experience with this simple apparatus, limited to one case, and it answered admirably. I am disposed to test still further its efficacy upon the authority of so good a surgeon.

Trusses are best made of a spring covered with some water-proof material, such as rubber or celluloid. The pads also should be made of hard rubber, celluloid, or hard wood, so as to be water-proof and hard. If they are made of soft material and covered with leather or chamois-skin, they become very dirty after a few days, the skin is often made sore, and, worst of all, they will not produce the pressure necessary either to keep the hernia reduced or to set up sufficient irritation to effect a cure. The spring, however, must not be too strong.

The pad which covers the inguinal ring should be slightly convex, but not so convex as is often seen, as it then presses into the already open ring, and by dilating it prevents its closing. The object should be to retain the hernia within the abdominal cavity, and to cure the hernia by exciting a local adhesive inflammation at the internal ring, thus restoring the integrity of the abdominal wall; and only pressure sufficient to accomplish this should be permitted. These being the objects, the pad should be placed over the *internal* ring, and not over the external, as we often see done. Applied at the latter place, the hernia can constantly escape into the upper part of the canal and so prevent a cure. The pad thus imperfectly applied will also press upon the pubes and cause great discomfort and local ulceration of the skin.

For children (except for umbilical hernia) the truss should always be double, as the predisposing causes always exist equally on both sides.

If the rupture be small and present only when violent efforts are made, it will merely be necessary for the child to wear the truss during the time it is out of bed. If, however, the rupture be large and persistent, then, for a time at least, the truss should be worn both day and night, to give nature an opportunity of closing the ring. In either case, whenever removed the truss should be taken off only *after* the child has lain down, and *never while erect*; and it should *always* be reapplied before the child rises, never afterwards. Omission of these precautions for a single time may undo the good of weeks of obedience to them, and even prevent a cure. Such exact care

FIG. 5.

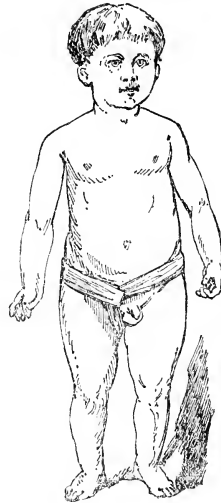

Truss of Berlin wool.

is always onerous, and in children often impossible; but it is none the less needful to insist upon it that the parents or the nurse shall give it, if we expect surely to cure so serious a disorder, which if it persists constitutes a life-long disability.

In all instances bathing with alcohol and water, or alum and whiskey, and dusting the skin night and morning with some one of the simple powders, corn-starch or violet powder, should be practised; and too much attention cannot be given to cleanliness and care in adjusting the truss.

The physician should not leave too much of the treatment in the hands of the instrument-makers, as they seldom have the requisite anatomical knowledge to guide them.

#### STRANGULATION.

Hernie in children frequently become strangulated; incarceration is extremely rare, for seldom has the hernia lasted a sufficient time for the sac to become adherent to the remains of the vaginal process of the peritoneum. When strangulation does occur, immediate efforts must be made to relieve it, as delay is quite as dangerous with children as with adults.

Strangulation is a constriction at the neck of the sac sufficient to obstruct the circulation and to paralyze the nerves, as well as to arrest the passage of the contents of the bowel. The constriction may be total, and if not speedily relieved is followed by gangrene of the gut; or it may be only partial, a small portion of the bowel being constricted and a linear ulceration caused, which, if unrelieved, eventually becomes a perforation, allowing the contents of the bowel to enter the peritoneal cavity and give rise to a violent peritonitis.

Occasionally the contents escape externally through the skin, forming a faecal fistula.

**Symptoms.**—The symptoms of strangulation are characteristic. There is persistent constipation. If the strangulation be slow there may be one or more stools, which unload the bowel below the constriction and are followed by constipation; but if it be sudden the constipation will be absolute.

The abdomen becomes distended; flatulent eructations occur, with colicky pains, which increase in force and are referred usually to the region around the umbilicus; vomiting soon sets in, at first of undigested food, then of chylous digesta, then of bile, and finally it becomes faecal. The latter is due to reverse peristalsis.

The abdominal distention and tenderness increase. The temperature, which at first is normal, rises to a moderate height, but as the obstruction persists it falls below normal. The pulse at first is rapid—120—and full, but becomes thready, weak, and then intermittent. The respiration is quick, shallow, and thoracic. The urine is generally decreased in amount, but varies according to the amount of sweating, which is almost constant.

There is great restlessness; the countenance becomes pallid and sallow;



the eyes are sunken; a cadaveric smell is noticed; and the little patient dies of exhaustion.

**Treatment.**—When the diagnosis of strangulation is reasonably certain, no time should be wasted in palliative measures.

An anæsthetic should be at once administered and efforts at gentle taxis begun. The tumor should be grasped between the fingers and gently compressed, in order, if possible, to press out some of the gaseous contents of the bowel. Then gentle efforts should be made, in the line of the inguinal ring and canal, to replace the gut, endeavoring always to return first that part of the bowel which came out last,—that is, the portion of the bowel in the canal and next to the external ring. Taxis should always be gently done, especially if the strangulation has persisted for more than an hour. If hiccough has set in, Mr. Birkett condemns the employment of taxis, and advises immediate operation. The general condition of the child must be considered, and if it be much exhausted operate at once.

The operation is performed in children as in adults, and must always be strictly aseptic. The parts should be carefully shaved, washed with alcohol or ether, and finally thoroughly but gently scrubbed with a one to four-thousand solution of bichloride of mercury. It is not advisable to use a stronger solution than this with children, as their skin is sensitive and may be blistered by it.

An incision is then made over the tumor in the line of its greatest diameter, which will be in the line of the inguinal canal, the skin and superficial fascia gone through, and the hernial sac exposed. It is generally necessary to open the sac in children, as the constriction is nearly always at its neck. The sac will be recognized by its glistening surface and by the distribution of its blood-vessels, and should be caught up with two pairs of forceps, and a small incision made between them.

A grooved director is now introduced, and an opening made which will freely admit the introduction of a finger. The constriction in children is seldom so great as in adults, and a director can generally be pushed past the constriction, a knife passed down along it, and the edge of the neck of the sac nicked upward and inward. The finger can then usually make sufficient dilatation to enable the bowel to be replaced.

If the bowel is in good condition, and no gangrenous or ulcerated points are discovered, it may be pushed back into the abdominal cavity. If, however, there be gangrene or much ulceration, the gut must be drawn out until healthy bowel appears both above and below; sponges are then to be packed around to shut off the peritoneal cavity completely, the bowel opened, the edges stitched to the skin, and an artificial anus made.

If the gut is in a satisfactory condition, an attempt should be made to effect a radical cure by bringing together the pillars of the ring. The hernial sac being generally the funicular process of the peritoneum, nothing can be done with that beyond passing a silk suture around it, in the hope of bringing it together.

Gerster, of New York,<sup>1</sup> recommends that in children no attempt be made to close the external wound by means of sutures, but that the wound be packed with iodoform gauze, in the hope that if the surface be allowed to granulate, a firmer cicatrix will result than if it be left to heal by primary union.

There is often great difficulty in keeping such a wound aseptic, as the child if young passes its urine over and soils the dressing and is generally very restless.

It is, however, usually better to introduce a rubber tube and horse-hair for drainage, and suture the wound and dress it with sublimate gauze, rubber dam, and a bandage, a hole being made in the rubber dam for the penis.

Dr. Royal Whitman, of Boston,<sup>2</sup> recommends that the leg be flexed upon the body and securely bandaged to a bent wire frame, known as Cabot's hip-splint. This apparatus in children is of great service in preventing the child from tearing off the dressing, and the fixation of the leg aids materially in effecting a rapid cure.

The diet for the first twenty-four hours should consist of nothing but a little milk and lime-water, given at short intervals, and must be liquid in character until the wound is entirely healed.

It will be necessary for the child to wear a truss afterwards for at least six months, and possibly a year.

Dr. Frank Woodbury<sup>3</sup> reports an operation for strangulated inguinal hernia in a child forty-five hours old, performed by Dr. Thomas H. Andrews.

The child was delivered at 5 P.M., August 10, 1874. There was difficulty in establishing respiration. He afterwards fretted as though in pain, and the mother detected a swelling in the right groin. The next morning the tumor was the size of an orange. Taxis, repeated after a warm bath and small doses of opium, was ineffectual in reducing the rupture. A second and a third attempt at taxis failing, at the end of forty-five hours, the tumor being then the size of the child's head, ether was administered, the sac opened, and the constriction at the neck of the sac relieved by the knife and fingers. The tumor was found to contain the greater part of the small intestine. The walls of the canal were brought together with sutures, and the child made a rapid and complete recovery.

Mr. J. Lionel Stretton, of Kidderminster, reports<sup>4</sup> a case of operation for strangulated inguinal hernia in a boy born July 28, 1886. On August 16 a rupture made its appearance on the right side, and was reduced. On the 25th it reappeared and became strangulated. Herniotomy was done in Mr. Stretton's office, and the boy completely recovered, without a bad symptom, by September 17.

Dr. L. W. Steinbach<sup>5</sup> reports a case of double inguinal hernia in a male child thirty-eight days old, with strangulation on the left side.

---

<sup>1</sup> New York Medical Journal, January 21, 1888.

<sup>2</sup> Boston Medical and Surgical Journal, March 22, 1888.

<sup>3</sup> Philadelphia Medical Times, December 25, 1875.

<sup>4</sup> Lancet, 1887, vol. i. p. 1029.

<sup>5</sup> Medical and Surgical Reporter, January 10, 1885.

The child was born September 2, 1884, and when Dr. Steinbach saw it all the symptoms of strangulation, with fecal vomiting, were present. Taxis was useless. On October 14 a free incision was made, the sac opened, a constriction at the neck of the sac relieved by the knife, and the bowel replaced. The ring was brought together for radical cure. Drainage and full antiseptic precautions were used. A phimosis was relieved at the same time. The wound healed, with no symptoms of peritonitis or inflammation anywhere. Death occurred, however, on the fifth day after the operation, but, Dr. S. thinks, from causes other than the hernia, as the child was weak, sickly, and jaundiced from birth.

#### RADICAL CURE.

In children an operation for radical cure is seldom necessary, as with care in the adjustment of the truss much can be accomplished. If the hernia be not retained by the truss, the child should be put to bed and kept on its back, as a truss which will not retain the hernia while the child is running about will frequently do so very well while it is in bed. If this is persisted in, a cure will generally be effected.

There is so much written in praise of the radical cure that we may be oversure of our results. When simple measures are so generally effective, why expose the little patient to such additional risks as all radical-cure operations necessarily involve? If, however, after persistent use of the measures just mentioned, the hernia cannot be retained, an operation must be undertaken.

For this purpose the operation of McBurney, of New York, is the best.<sup>1</sup>

The sac is carefully separated from the cord and opened, the gut replaced within the abdominal cavity, and a ligature of silk thrown around the sac as high up as possible, care being taken to keep the finger well inside the sac while the ligature is being tightened, to prevent the possibility of including the gut within the ligature. The sac is then cut away, and the stump is transfixed with a needle armed with a stout silk ligature and is stitched into the ring. Deep sutures of relaxation are then introduced to bring down and partially invest the sides of the wound, but not to close it. The incision in the scrotum is now sutured, and the wound over the ring packed with iodoform gauze and allowed to heal by granulation.

As the wound is an open one, drainage is perfectly free and the resulting cicatrix is very firm. After six weeks in bed the patient is allowed to get up and begin to go about without a truss.

#### FEMORAL HERNIA.

Femoral hernia is extremely rare before the age of puberty, and is never congenital. Swasey (*loc. cit.*) reports the following extraordinary case:

A boy aged sixteen years presented himself at the hospital with unmistakable double femoral hernia, with the following history, which was given by his mother in such a distinct and careful manner that little doubt can be felt as to the truth of it. He had when one year old a bad bronchial affection, with severe cough, and during this time the tumors

<sup>1</sup> New York Medical Record, March 23, 1889.

appeared. They would disappear on lying down, and increase in size on standing up, and especially upon coughing. The boy said the lumps had been present as long as he could remember.

Dr. Swasey mentions also another case, a girl twelve years of age, whose mother positively asserted that the swelling had been present for four years.

Mr. Thomas Bryant<sup>1</sup> reports two cases, both girls, aged nine and twelve years respectively. In both instances the herniæ were the direct result of violent exertion. A truss completely relieved them.

The rarity of femoral hernia in children is due to the anatomical relation of the parts. The points of attachment of Poupart's ligament, the spine of the pubes and the anterior superior spine of the ilium, are comparatively near together during childhood, as the pelvis has not attained its full growth, and the space between the ligament and the border of the bony pelvis is so slight that it is difficult for the gut to push its way through the femoral opening. The muscles, the iliacus and the psoas, are well developed, and, with the vessels, completely fill the space.

When it does occur, it is generally in children of poor muscular fibre and debilitated from long illness or great poverty, with its accompanying loss of tone and muscular wasting.

The diagnosis is not difficult. A tumor appears suddenly in the groin, below Poupart's ligament and directly over the saphenous opening. The tumor is elastic, resonant, can be generally returned without difficulty into the abdominal cavity, and has the gurgling characteristic of all herniæ. It increases in size when the patient is standing erect, and gives an impulse on coughing.

The treatment must be directed to returning and retaining within the abdominal cavity the protruded gut with its sac. This can best be done by a properly-fitting truss, of the same material as those already recommended for the inguinal varieties of hernia, but slightly modified as to form. Femoral hernia in children might become strangulated, and, if so, the administration of an anæsthetic and taxis would be required. If taxis fail, herniotomy must be performed, and differs in no particular from such an operation performed upon an adult.

#### DIAPHRAGMATIC HERNIA.

Diaphragmatic hernia is an extremely rare condition, and may be either congenital, which is by far the most common form, or traumatic.

The symptoms are pain and dyspnoea, and by auscultation the movements of the intestinal gases may be heard within the chest-cavity. If traumatic, there may be acute internal strangulation.

Dr. Henry J. Bowditch, of Boston,<sup>2</sup> reports several cases of diaphragmatic hernia as congenital in children. One was a young man of seventeen,

<sup>1</sup> Medical Times and Gazette, 1862, vol. i. p. 136.

<sup>2</sup> Buffalo Medical Journal, 1853.

with complete absence of diaphragm on the left side. The pleura contained the stomach, the major part of the colon, and several loops of small intestine. One case was four years of age, and one was seven years.

Nothing can be done in the way of treatment in the congenital variety. In the traumatic, if there are symptoms of strangulation, laparotomy or opening the chest and suture of the diaphragmatic opening, as in the unique case of O'Dwyer,<sup>1</sup> give the only possible chance to aid the little sufferer.

#### LUMBAR HERNIA.

Mr. Edmond Owen<sup>2</sup> reports the case of a girl aged five and a half years, who about a year before he saw her had fallen down-stairs and injured her back. An abscess formed and opened spontaneously above the left hip-bone, leaving for a long time a sinus, through which pus was discharged. Some months after the sinus healed, a painless swelling appeared at the seat of the old sinus. This swelling was about the size of a small orange, and was just above the left iliac crest, in the interval between the anterior border of the latissimus dorsi and the posterior border of the external oblique muscles,—the triangle of Petit. This swelling was resonant, and its contents could be completely returned within the abdominal cavity; it slipped back spontaneously when the child lay on the right side. A clearly-defined abnormal aperture, as large as the end of a man's thumb, could be demonstrated. A cough would at once drive the bowel again into the sac: it was probably a portion of the colon, as hardened masses, supposed to be feces, could be felt within it. He performed an operation for radical cure, by making an incision down to what he supposed to be the transversalis fascia, thrusting back the sac and its contents within the abdominal cavity, and approximated the edges of the latissimus dorsi and external oblique muscles by deep sutures. The child made a complete recovery.

Mr. J. Hutchinson, Jr.,<sup>3</sup> in a paper on lumbar hernia, mentions four other cases occurring in children. Two were congenital, and in one of these the tumor was supposed to be a lipoma; one followed directly after a fall; and another followed the healing of a spinal abscess.

The diagnosis is not difficult; but the tumor has been mistaken for an abscess, incised, the gut opened, and a fecal fistula resulted. The absence of true fluctuation, with the resonance on percussion and the facility with which the contents of the swelling can be returned within the abdominal cavity and its increase in bulk on coughing, should prevent such a mistake; and, although the condition is very rare, the possibility of such an occurrence must be borne in mind.

The treatment should consist in the application of a well-fitting abdominal belt to retain the hernial protrusion, and generally this is sufficient. Mr. Owen, in the case just mentioned, was the first to perform an operation for the radical cure of the condition, and his plan should be tried if the simpler means fail.

The following curious—and, I believe, unique—case is reported by Dr. W. T. Wilkins, of Kansas:<sup>4</sup>

---

<sup>1</sup> New York Medical Record, October 12, 1889.

<sup>2</sup> British Medical Journal, 1888, i. 957.

<sup>3</sup> *Ibid.*, 1889, ii. 71.

<sup>4</sup> St. Louis Medical and Surgical Journal, June, 1888, p. 340.

During a violent wind-storm a young woman in the eighth month of pregnancy was made insensible by being struck in the abdomen by the corner of a table.

Labor set in on the following day, and she was delivered of a male child with a peculiar "hunch on its back." Dr. Wilkins saw the child on the sixth day after delivery, and found the "hunch" of a purple color and about the size of a goose-egg. He diagnosed a hernia at the juncture of the last dorsal with the first lumbar vertebra, and operated on the following day.

A longitudinal incision about four inches long was made over the hernial sac, when it was found that the vertebrae were separated to the extent of half an inch. Through this separation protruded the hernia. The spinal cord had been pushed to one side. The hernia was returned without opening the sac, the cord carefully replaced, and the vertebrae brought into exact apposition. To keep the bones in place, a carbolized silk ligature was passed through the superior intervertebral notch of the dorsal vertebra, into the superior intervertebral notch of the lumbar vertebra, through the inferior intervertebral notch of the lumbar, back on the opposite side through the superior intervertebral notch of the dorsal vertebra, repeating this three times, and making a figure-of-eight knot binding the bones firmly in position. The external wound was closed with catgut sutures, the whole dusted with iodoform, and the dressing finished with a broad rubber bandage. Antiseptic precautions were observed throughout the operation, which lasted about half an hour. The wound healed by first intention, and the child was practically well in six days.

Mr. T. Holmes reports<sup>1</sup> the case of a female child aged three years, in whom a tumor protruded behind the labia minora, between the urethra and the vagina, clearly an extension of the vesico-vaginal pouch of the peritoneum.

It contained intestine, which was very easily reduced, leaving a distinct ring where it had protruded. As the tumor increased in size, he reduced the hernia into the belly, dissected flaps of mucous membrane off each side of the vagina, and united the parts around the ring by numerous sutures. Union took place by granulation and contracted the ring, and a cure, at least for the time the child was under observation, was effected.

---

<sup>1</sup> Surgical Treatment of the Diseases of Infancy and Childhood, 1868, p. 560.

# INTESTINAL OBSTRUCTION IN CHILDREN.

By W. W. KEEN, M.D.

---

INTESTINAL OBSTRUCTION is a mechanical impediment to the passage of the contents of the intestinal canal. For clinical purposes it is usual to divide the causes into three classes,—*acute*, *subacute*, and *chronic*. An acute obstruction may become subacute or chronic, and a chronic case may become acute. It is, therefore, sometimes difficult to determine accurately the condition we have to deal with, for one form may take on a few or many of the symptoms of the other. Mr. Fred. Treves<sup>1</sup> describes yet another class, which he calls *ultra-acute*: here the symptoms are so severe that death occurs within a few hours, and we are powerless to aid.

In acute cases the attack is always sudden, the symptoms are violent, and the diagnosis is frequently difficult. The prognosis is always grave, for, unless the cause of the obstruction be removed and immediate relief be had, death will speedily ensue.

Subacute obstruction has many of the symptoms of both the acute and the chronic condition. The attack is not so sudden, neither is it so violent, while the demand for relief is not so urgent, and the obstruction may assume a chronic form.

Chronic obstruction, on the other hand, comes on more slowly, the symptoms are not so urgent, nor is the danger of death so imminent. Chronic obstruction may even be spontaneously relieved.

The most common causes of acute obstruction are congenital malformations, such as imperforate anus, absence of rectum, and atresia of the intestine due to fetal peritonitis. As these conditions are fully discussed in another place in this volume, they need only be mentioned here.

Of other causes of intestinal obstruction the most common are foreign bodies, volvulus, intussusception, and constrictions due to bands and other similar mechanical causes. These will now be considered in the order named.

## FOREIGN BODIES.

Either accidentally or intentionally, children frequently swallow foreign bodies, which by their presence within the intestinal canal cause obstruc-

---

<sup>1</sup> Jacksonian Prize Essay on Intestinal Obstruction, London, 1884.

tion. They act either by their bulk, mechanically obstructing the lumen of the gut, or by the irritation that they produce, which causes inflammatory swelling of the intestinal wall and finally obstruction. The variety of these foreign bodies swallowed by children is very great, and it is wonderful how many and how large in bulk some of them are,—fruit-seed, cherry-stones, marbles, bullets, coins of all sizes, needles, cocoa-nut fibre, wool, and, in fact, almost anything which it is possible for them to get into their mouths. Sometimes nature is overtaxed and does not permit the foreign substances to pass per anum, as they generally succeed in doing, and they become lodged in some portion of the gut, when in a little while inflammation is set up and occlusion occurs. Thus, Dr. W. R. White<sup>1</sup> has reported the case of a little girl one year of age, with an obstruction of the intestine caused by woollen carpet-threads which she had swallowed. Dr. N. S. Bates, of the United States Navy,<sup>2</sup> gives a very interesting account of several cases of obstruction in children due to banana-seed. The children were living in Japan, where this fruit formed a large part of their diet.

Dr. H. G. Taylor<sup>3</sup> mentions three cases of intestinal obstruction in idiots, in whom death was due to masses of potato-parings, slate-pencils, sticks, wool fibre, and seybala.

Obstruction may also be caused by masses of intestinal worms, as is shown by a case mentioned in the *British Medical Journal*, 1888, ii. 86, as being reported by Stepp in the *Centralblatt für die medicinisch. Wissenschaft.*, No. 27, 1888. A boy four years old had an acute intestinal obstruction, and died within an hour and a half after medical aid had been summoned. The post-mortem showed the intestines completely occluded by a twisted mass of some forty or fifty round worms, which had lodged just above the ileo-cæcal valve. The ileum higher up contained some thirty-five more, and a few were found in the stomach and œsophagus. He had been given by his mother some "worm medicine" two days before he died, and then the next evening a heavy meal of smoked bacon and sauer-kraut. Dr. Stepp thinks the worms were weakened by the medicine, and were then dislodged in great numbers by the violent peristalsis induced by the injudicious meal the following evening, and so rolled down in a tangled mass too large to pass the ileo-cæcal valve.

Leichtenstern<sup>4</sup> expresses his doubts about the possibility of intestinal worms ever being a cause of obstruction, and considers it not proved; but the case above cited seems to establish the fact.

If the foreign substance swallowed be small and round, it generally passes along the gut, is expelled per anum, and rarely gives any serious trouble. If, however, it be very small, it may drop into the vermiform appendix or some other diverticulum and cause serious mischief.

---

<sup>1</sup> Rhode Island Med. Soc. Reports, 1886, Part IV., p. 336.

<sup>2</sup> Amer. Jour. Med. Sci., 1887, vol. xciii. p. 44.

<sup>3</sup> Lancet, 1887, ii. 255.

<sup>4</sup> Ziemssen's Cyclopædia of Medicine, vol. vii. p. 583.



Sharp bodies, such as needles, may penetrate the walls of the stomach and gradually work their way into some more distant organ.

The symptoms of obstruction by foreign bodies are sometimes very vague and ill defined, and we must depend in great measure upon the history of the case. The diagnosis, consequently, may be difficult. These substances occasionally remain in the stomach for a long time without causing any dangerous symptoms, and are finally vomited, or they pass downward into the intestines. Here they move forward and downward little by little until they reach the ileo-cæcal valve, and if they be not too large to pass this, the narrowest part of the gut, they continue on into the colon and rectum, whence they are either expelled spontaneously or removed by the finger of the surgeon. Sometimes the foreign body can be felt by the hands through the abdominal wall, and its progress followed step by step along the intestinal canal. When, however, it becomes lodged,—and this is most frequent just above the ileo-cæcal valve,—the bowel quickly becomes inflamed, the obstruction by the swelling of the mucous membrane becomes absolute, and a dangerous peritonitis ensues. As the foreign substance moves slowly onward, the little patient has a feeling of great discomfort in the abdomen, with colicky pains, straining, and frequent desire to go to stool, especially when the offending mass is low down. When lodgement in the gut occurs, the pain increases, abdominal distention becomes marked, and a violent peritonitis begins.

**Treatment.**—It has long been a popular notion that as soon as a child has swallowed a pin, needle, or, in fact, almost any foreign substance, a purgative must be given, in the hope of causing an immediate expulsion of the offending body. For this purpose the mother generally doses the child with castor oil. Nothing could be more injudicious than this plan of treatment, for peristalsis is thereby increased and the foreign body with its sharp points is much more liable to do injury to the intestinal wall. The child must be given food which will have much solid residuum,—oatmeal, unbolted flour, corn-meal, meats, etc.; for experience has shown that by so doing the foreign body becomes surrounded by hardened fæces, which protect the delicate mucous membrane from injury.

Marked success has recently followed the so-called “potato cure” for foreign bodies. Large quantities of potato being eaten, it is claimed that by this the whole intestinal canal is proportionately dilated and the foreign body is prevented from lodging at any point.

When the foreign body becomes lodged in the intestine at a point too high to be reached by the finger in the rectum, laparotomy offers the only chance for life.

A full description of the steps of the operation will be given later on. Here it is only necessary to say that, when the offending body is found, that portion of the gut surrounding it must be drawn out of the belly, the wound packed carefully with sponges to protect the peritoneal cavity from contamination, an incision made into the gut parallel with its long axis, and

the foreign substance removed. The wound in the gut must then be carefully cleaned with hot boiled water, and the incision quickly closed by a continuous silk thread introduced with a small cambric needle after the manner of the Lembert suture. A right-angle continuous Lembert suture, as described by Dr. H. W. Cushing ("Boston City Hospital Report," 1889), is quite as effectual as the interrupted one, and much more rapid in its application: the amount of time necessary to make each separate knot of the ordinary Lembert suture is considerable, and there is difficulty in holding the moist and slippery gut.

If the obstruction has persisted for a sufficient length of time for gangrenous changes to take place, an artificial anus, to relieve the acute symptoms, must be formed; or, if the condition of the child warrants a continuation of the operation, resection of the gut and lateral anastomosis by Senn's plates<sup>1</sup> or Abbe's rings<sup>2</sup> or by the ingenious method with small rubber tubing made into a ring by a catgut thread passed through its lumen, as proposed by Brokaw, of St. Louis, in the *Weekly Medical Review* for August 17, 1889, may be undertaken.

#### VOLVULUS.

Among children volvulus, or the twisting of a portion of the gut upon its mesenteric axis, is rare. It is due to a congenital abnormally elongated and relaxed mesentery.

Leichtenstern<sup>3</sup> mentions the case of a boy aged eleven years who died of pseudo-leukæmia without having any symptoms especially referable to the intestines. At the post-mortem examination a true volvulus of the sigmoid flexure of the colon was found. Mr. Cleland Lammiman<sup>4</sup> reports the case of a child three years old upon whom he performed an unsuccessful laparotomy for acute intestinal obstruction due to volvulus of the sigmoid flexure. Volvulus may also occur in the small intestine and in other parts of the colon, but the most common site is at the sigmoid flexure. The mesentery must necessarily be elongated and relaxed to permit of the gut's rotating upon itself, and in children this elongation is always congenital. Some limited portion of the bowel becomes paralyzed, generally from over-distention caused by the gases evolved in imperfect digestion, and, from the loss of muscular tone, is easily twisted. The loop of intestine within the constriction is always enormously distended; the circulation is at first impeded and finally cut off altogether.

In adults, on the contrary, it is usually acquired, and arises in chronic constipation, from the weight of large masses of fæces, which pull down and drag upon the mesentery, thus causing its relaxation and elongation. It may also arise from long-standing hernial protrusion. Seldom has the congenital condition much to do with its formation.

<sup>1</sup> Annals of Surgery, Jan., 1888.

<sup>2</sup> New York Med. Jour., March 23, 1889.

<sup>3</sup> Ziemssen's Cyclopaedia of Medicine, vol. vii. p. 562.

<sup>4</sup> Lancet, 1887, ii. 829.

**Symptoms.**—For some time before the acute attack, it may be days or even weeks, there are evidences of imperfect digestion, flatulent distention of the abdomen, with constipation accompanied by colicky pains. When the twisting of the gut occurs, the onset is sudden, with violent pain, which is not, however, so severe as in strangulation by bands, and is intermittent in character. There is absolute constipation, and no escape of either flatus, mucus, or feces by the rectum. The abdomen becomes greatly distended with gas, and is soon very tender. Prostration and collapse are not developed so early as in strangulation by bands, neither are they so extreme. Vomiting comes on rather late, and is never very urgent. At first it consists of undigested food, and may finally become fecal, although the latter condition occurs in only a very small number of cases.

The diagnosis is to be made from the other forms of acute obstruction by the sudden onset, tenderness of the abdomen, meteorism, and absolute constipation. There is no discharge of bloody mucus from the anus, neither can any tumor be demonstrated through the belly-walls or by the finger in the rectum; there are also the character of the vomiting and its late appearance.

**Treatment.**—Of course the treatment is most unsatisfactory, and, if the volvulus is left unrelieved, death is absolutely certain. Experience has shown that the volvulus can only occasionally be untwisted, after laparotomy has been done, and that almost immediately it will recur. It is possible that puncture or incision of the distended loop of gut, to permit the escape of the accumulated gases, will allow the volvulus to untwist itself, but it has generally been thought better to make an opening into the gut above the seat of constriction, and form an artificial anus.

I would suggest as an improvement that either the untwisted volvulus be sewed fast to the belly-wall at two or three points, so as to prevent its re-twisting, or, perhaps even better, that lateral anastomosis of the intestine be done above and below the volvulus, by Senn's bone plates, Abbe's catgut rings, or other similar means, with resection of the twisted portion of the gut if its life is endangered. Both of these suggestions seem worthy of consideration and trial in so desperate a disorder.

#### INTUSSUSCEPTION.

A portion of intestine may pass into another adjoining portion, the lumen of the bowel is closed by the resulting pressure, and we have the most frequent form of intestinal obstruction,—namely, invagination or intussusception.

The direction of an invagination is always downward, in the direction of the normal peristalsis; that is, that portion of the intestine which receives the other is always on the lower or anal side. There may be two invaginations occurring at the same time in different portions of the gut, or there may be a second portion of gut forced into an already existing invagination. These are, however, extremely rare.

The intussusception consists of three parts, or layers: a *receiving* or *outside portion*, called the *INTUSSUSCIPIENS* or sheath, a *middle* or *returning portion*, and an *internal* or *entering portion*; these latter two taken together form the *INTUSSUSCEPTUM*. The middle or returning portion is literally turned inside out, like the finger of a glove when it is stripped off the hand. All intussusceptions are complete, in that they consist of all the coats of the bowel and enter the sheath evenly.

A glance at the accompanying cut, taken from Mr. Fred. Treves's Essay, the most exhaustive and careful of recent works on the subject, will show the condition very plainly. It will be

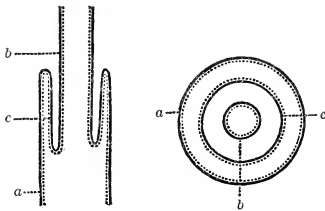

VERTICAL AND TRANSVERSE SECTIONS OF AN INTUSSUSCEPTION.—(a) The sheath or intussusciens; (b) the entering or inner layer; (c) the returning or middle layer. (Treves.)

seen that mucous membrane lies in contact with mucous membrane, and peritoneum with peritoneum, and it can readily be understood how great are the dangers from the cutting off of the blood-supply by pressure and from the rapid adhesions of the two adjacent layers of peritoneum. Treves estimates that three-eighths of all cases of intestinal obstruction are due to intussusception, and that fully fifty per cent. of these occur

under the age of ten years, and twenty-five per cent. in the first twelve months of life.

Boys suffer more frequently than girls. Jacobi reports the proportion in his eight cases as six boys to two girls, and Mr. Gay (quoted by Treves) as one hundred and sixty-three boys to ninety-three girls, all under one year of age. This relative disproportion gradually diminishes as the age increases.

**Causes.**—Many theories have been advanced to account for this condition, and but few have stood the test of time. The one most probable, from all the evidence and from experimentation upon the lower animals, is irregular action in the muscular walls of the intestine. The intussusception occurs at some point in the intestine where there is a limited and severe muscular contraction, and especially is this so with irregular contraction in the longitudinal layer, or where some portion is paralyzed and joined to that which is still active. Hence the division into spasmodic and paralytic invagination; but for clinical purposes this division is of little value. The previous history is of slight importance, for in about one-half of all the cases the children have been reported as perfectly well and strong, when suddenly and without a moment's warning an invagination formed.

Intussusception is most common in infancy, and is frequently associated with the disorders of digestion consequent upon the change of diet from the mother's breast to the milk of cows, and at a time, too, when the nervous processes are most active and peristalsis most vigorous. Diarrhœa (although

this is denied by Jacobi), colic, tenesmus, and constipation, all play a considerable part as etiological factors. In one of Jacobi's cases a perfectly healthy child was being jumped up and down in its nurse's arms, when it suddenly cried out with pain: an invagination had formed. Whooping-cough, with its violent paroxysms, is also mentioned as a cause.

Frequently at post-mortem examinations, when death has occurred from some other cause, and where there have been no symptoms especially referable to the intestinal canal, invaginations are found. These are due to a continuation of peristalsis after death, the intestine dying last. They are generally found in the small intestine, show no evidences of inflammatory action, and are reduced with the greatest facility.

A polypoid tumor attached to the wall of the intestine, generally in the neighborhood of the ileo-cæcal valve, or in the transverse colon, may by its presence, especially if there be diarrhœa, increase the muscular efforts of the intestine to such an extent that, by dragging at the point of attachment, an invagination is produced. Mr. Arbutnot Lane reports<sup>1</sup> the case of a child eight years old who, after an attack of diarrhœa following chronic hip-joint disease, had an invagination produced by such a tumor. It was sessile, and about the size of a walnut. It projected from the anus, and was mistaken by the child's nurse for a prolapse of the bowel, and was returned into the rectum, where it was held by a pad and binder. When its true nature was discovered, the tumor was removed without difficulty, and the invagination reduced.

Invagination may occur at almost any portion of the intestinal canal. Small intestine may slip into small intestine, large intestine into large intestine; but by far the most common position, especially in children, is at the ileo-cæcal valve, which slips into the large intestine. Treves states that the latter condition is found in seventy per cent. of all cases of babies suffering from intussusception. The anatomical relations are such that the slightest alteration in the physiological conditions permits the ileo-cæcal valve to slip into the large intestine, and when once this occurs the peristaltic movements are excited to increased activity by its presence, and the invagination is pushed farther and farther until the rectum is reached, where it may even protrude from the anus. Rarely retrograde, double, and triple intussusceptions are found.

**Morbid Anatomy.**—When the abdomen is opened after death from acute intussusception, very little is seen at first. Death usually occurs in so short a time after the onset of the condition that the peritoneum is only slightly altered, but the small intestine appears more or less distended and displaced, with its mesentery twisted. The cæcum and more or less of the colon are absent from the normal position, and the colon appears to take its origin from a knob-like mass of the bowel in the course of the ascending or transverse colon. On examining this mass carefully,

<sup>1</sup> *Lancet*, 1887, i. 731.

it is found to be hard, doughy, inelastic, and varying in size from that of an egg to a mass six inches long. It is livid in color, and ecchymotic, showing evidences of great congestion. The condition of the bowel varies very much with the length of time which has elapsed since the invagination formed.

If death has occurred within twenty-four hours, as frequently happens from shock, very little else will be seen. When, however, two or three days have elapsed, a mass of inflammatory lymph has been thrown out from the congested peritoneal surfaces, which glues together the invagination and makes reduction, without tearing the walls of the bowel, impossible. Generally the tumor is curved, owing to the twisting and drawing in of the mesentery with the entering layer of the gut, and is of a deep claret-color from extravasated blood. When the constriction has lasted long enough and been of such intensity as to cut off the blood-supply completely, the mucous membrane sloughs, and will be found ash-colored or even gangrenous throughout.

Our attempts at reduction of the invagination by manipulation are generally only partially successful, for, of course, it is only in the most severe cases that we have the opportunity of trying to do this, and great force is required to accomplish the result. The curving of the tumor, with its mesenteric attachments, makes it almost impossible to do it by direct traction without rupturing the bowel, and this frequently occurs when only very gentle force is exercised. Reduction can often be accomplished, provided the adhesive lymph be not too old and firm, by the conjoined use of manipulation of the tumor, as described later, aided occasionally by a forced current of water introduced well up the rectum.

In an ordinary acute case the veins alone are compressed, the arteries still supplying blood, and the gut soon becomes enormously thickened. It is from the venous congestion that the blood-stained mucus comes, one of the most important symptoms in our diagnosis. When the case has been ultra-acute both the veins and the arteries are compressed, the blood-supply is totally cut off, and within a few hours the gut has sloughed. This condition occurs generally in the invaginations of the small intestine, where the pressure will be very severe from the small size of the intussusciptions.

**Symptoms.**—The symptoms in an acute case (and this is most frequent in children) are very sudden in their onset when the invagination is at the ileo-cæcal valve, and rather more gradual when it is situated in the colon and rectum. The child is apparently perfectly well, when suddenly, while exercising, or, it may be, during sleep, it is seized with acute colicky pains and cries out violently; the pains are paroxysmal in character, due to the irregular peristalsis, and rapidly increase in severity.

The abdomen at first is soft, and not at all tender to the touch, and it may even give the little patient comfort to apply gentle pressure with the hand. This condition of affairs soon changes as congestion and peritonitis set in, and the abdomen becomes distended, tympanitic, and painful. Signs

of collapse very soon appear; the face grows pallid and anxious, the eyes become sunken, the skin is covered with a cold sweat, and the pulse is rapid and weak.

Vomiting sets in, but not so early nor so constantly as in strangulation of the gut in hernia or by bands. At first the vomited matter is undigested food, and it becomes fecal in only about twenty-five per cent. of the cases. Sometimes when the invagination is in the small intestine blood is vomited. This is due to the intense congestion at the point of invagination, and is very rare in the ileo-cæcal variety. One case, at least, has been reported in which vomiting was excited by the introduction of the finger into the rectum for purposes of diagnosis: at each repetition the vomiting recurred. In the chronic variety vomiting may be absent altogether, or not at all constant. Mr. R. W. Parker<sup>1</sup> reports two fatal cases of intussusception in infants three and four months of age respectively, in which vomiting occurred only during the first twelve hours, and then only after taking the breast. He explains this by the fact that the invagination was very acute and the gut speedily became gangrenous.

When the invagination exists in the small intestine, indican will be found in the urine.

Generally there is diarrhoea at first, an unloading of the intestine, especially below the constriction, with violent peristalsis and tenesmus. After the first few hours, or in very acute cases almost immediately, the discharge becomes the characteristic blood-stained mucus. Mr. Treves mentions one case of ultra-acute invagination in which the discharge of blood by the bowel was so great as to cause death from the hemorrhage. Tenesmus is rarely absent, and increases in severity the nearer the intussusception is to the rectum; although Mr. Parker states that in the cases of fatal invagination just mentioned there was no straining or tenesmus whatever. Generally, after the first few hours, constipation is marked.

The temperature at first is normal or nearly so, but as the urgency of the symptoms increases, and the shock grows more profound, it becomes subnormal. Thirst is a constant and distressing symptom, but depends in a great degree upon the vomiting and sweating, increasing with their severity. The flow of urine is slightly diminished, and this is most marked if there is profuse sweating. The higher up the seat of the obstruction, the more marked is the diminution in the quantity of urine.

In a large proportion of the cases a tumor can be demonstrated by *careful* palpation of the abdomen, and is of the utmost importance in diagnosis. A sausage-shaped, doughy, inelastic mass may be detected in some portion of the colon, generally on the left side in the descending colon; it is curved, owing to the tension of the mesenteric attachments. At the very onset this tumor will exist most frequently just above the cæcum, but as more and more of the bowel becomes invaginated the tumor gradually changes its

---

<sup>1</sup> British Medical Journal, June 2, 1888.

place, following the course of the colon, till it is finally found on the left side. It varies in size from that of an egg upward, but is rarely longer than six inches. A careful examination of this mass during a paroxysm of pain is important, to determine if its size or tenderness is increased, as well as to learn whether it is fixed or movable.

Frequently the intussusception can be felt by the finger introduced into the rectum,—a mass smooth and rounded, not unlike the cervix uteri, though softer, with a rounded slit-like opening in its centre, the lumen of the gut. This may even protrude from the anus, and in at least one instance it has been excised in mistake for a polypoid growth.

Chronic cases of intussusception in children are almost always of the ileo-cæcal variety, and may last for several months, causing only ill-defined symptoms. Strangulation, as a rule, does not occur, and the mass of ensheathing lymph which so tightly binds together an acute invagination does not form. This condition of things may remain for weeks or even months, the little patient suffering more or less pain, with partial obstruction to the passage of fæces, while the invagination is gradually being forced downward by the peristaltic movements, and frequently, as has been said, protrudes from the anus. The pain at first is paroxysmal, and there may be long intervals during which it is entirely absent. After a time there may be vomiting, but this is not constant.

The lumen of the bowel is not entirely closed, and fecal matter from above the seat of invagination is permitted to pass. The condition grows gradually worse: the discharges from the bowel become mucoid, and finally bloody,—an especial characteristic of intussusception,—the pain increases in severity and is more persistent, the vomiting becomes constant, and the little sufferer finally dies of exhaustion.

At any time these chronic cases may suddenly take on acute symptoms. A tumor, if carefully searched for, will be found, with its characteristic doughy feel and sausage-shaped outline, in the ascending, transverse, or descending colon, and the finger in the rectum will be able to detect the advancing invagination. A point in the diagnosis between chronic invagination and fecal impaction is the fact that the tumor in invagination moves its position and gradually advances, while the tumor of fecal impaction remains stationary.

**Diagnosis.**—The diagnosis may be very easy, or most difficult. When a child seemingly in perfect health is taken with sudden and intense pain, followed by vomiting, and by the passage of blood-stained mucus from the anus accompanied with violent straining; when, after the unloading of the bowel below the constriction of what fæces it contained, there is constipation, and after a time collapse; and when a tumor is found in the abdomen which follows the line of the colon, and which changes its position and can possibly be felt by the finger introduced into the rectum,—all doubt must at once be at an end. If the character of the tumor which is felt through the abdominal walls is doubtful, and nothing can be found by the finger in



the rectum ; if it does not contract or change its position under the hand,—then, to solve the question, an injection of water should be used. If, however, the above-mentioned signs are present, little if anything can be gained and everything may be lost by delay in taking active measures for relief.

The constriction of the invagination by the ensheathing layer causes inflammation and sooner or later a sloughing off of the invaginated portion of the bowel. Sometimes the sloughing process does not take place for a long time, and we may never expect it in children under two years of age ; for with them the inflammation of the bowel is almost certain to terminate fatally within from thirty-six hours to three or four days. We may sometimes, however, expect this termination in children of six years and upward, though even with them it is not the common result. Even after the invaginated portion has sloughed and come away, the child is still in danger from ulceration and possibly constriction of the gut by cicatricial bands or contraction. It seldom entirely recovers, but dies, it may be months afterwards, of exhaustion.

Mr. Harrison Cripps<sup>1</sup> reports the case of a child seven months old who when brought to him had been ill for a fortnight, with an intussusception which hung outside the anus and was in a gangrenous state. The slough came away bit by bit each day for a month, when the child was discharged from the hospital cured. Subsequently the child died of scarlet fever, and at the autopsy the small intestine was found attached to the anus. There were no traces of the ascending, transverse, or descending colon : these must have all sloughed away.

Dr. Obtulowicz reports<sup>2</sup> the case of a boy thirteen years old who after a fall had violent pain in the right iliac region, which was shortly followed by bloody mucous stools. He had pain and a bloody diarrhoea for two weeks, when a tumor was noticed in the region of the pain. A week later he passed at stool a piece of dead bowel twenty centimetres long, which consisted of the cæcum, with its appendix vermiformis, and an invaginated portion of the ileum, together with a fragment of the mesentery. The boy made a good recovery, but was again injured, and died after a year's illness, it was supposed from fecal extravasation.

All intestinal obstructions in young children have a tendency to run an acute course, and, unless active measures for relief be instituted within a few hours after the onset of the disease, death quickly ensues. In chronic obstructions, on the contrary, the prognosis is not necessarily so grave, as spontaneous recoveries have been known to occur (*vide supra*) ; but this happy result must not be expected in the vast majority of cases.

**Treatment.**—Intussusception in children when unrelieved is so rapidly fatal, and the statistics of large numbers of cases show conclusively that the delay of even a few hours is so unwise, that, as soon as a diagnosis is determined upon, a definite course of action should be instituted, and attempts made by some means to replace the invaginated bowel.

Purgatives must not be given under any consideration whatever, as they

<sup>1</sup> British Medical Journal, June 2, 1888.

<sup>2</sup> Annals of Surgery, July, 1889, p. 77,—a translation from Wiadomosci Lekarskie, October, 1888.

can do no good, and will do positive harm by increasing the peristaltic movements of the bowel and so produce further invagination and possibly rupture of the gut. Opium in some form (and opium itself is better than one of its preparations) is absolutely demanded. It diminishes pain and consequently shock, it arrests the excessive peristalsis, thus preventing further invagination, and by its power of allaying irritation it may possibly permit of spontaneous reduction of the intussusception. Great care in its administration must be exercised, lest its soothing effects give false confidence, and other measures of relief must be used in conjunction with it.

In the early stages, within two to three days, before firm adhesions have formed, unless the symptoms be ultra-acute, the child should be placed under the influence of an anæsthetic and attempts made to reduce the invagination by means of enemata of warm water. The child, when thoroughly under the influence of the anæsthetic, is placed on a soft pillow, with the hips raised, and, warm water in a fountain syringe being in readiness, the injection-pipe is introduced well into the rectum, and the water allowed to flow by gravity and quite slowly into the bowel. The utmost gentleness must be exercised throughout the manipulations, and no sudden forcible injection used: the force of the column of water is to be regulated by raising or lowering the bag of the syringe. At the same time gentle manipulation of the abdomen is to be made by an assistant. If this be not successful at first, the child should be inverted,—a manipulation of great importance, as gravity will materially aid in the reduction. In an excellent paper in the *American Journal of Obstetrics* (1886, p. 673) Forest gives the result of both clinical and experimental studies on this subject. He has shown that such injections are of little if any use in the small intestine, and that the large bowel bore a pressure in children of eight or nine pounds to the square inch before it ruptured. He therefore advises that the child be taken into the hall (so as to get sufficient height) and that the bag of the fountain syringe be gradually raised until it is fifteen to twenty feet above the child's hips. Each two and a half feet of height will represent one pound to the square inch. The tube of the syringe will have to be correspondingly lengthened. The nozzle recommended is to be large (as the sphincter is dilated), and he has used a glass vaginal syringe resembling a test-tube. It must have a good shoulder of bandage, to occlude the anus. I am decidedly inclined, however, to recommend not to use a pressure above five to six pounds (*i.e.*, twelve to fifteen feet), as I think that Forest has not given sufficient weight to the softened condition of the bowel when invaginated,—a condition that did not exist in the children's cadavera upon which he experimented.

Insufflation by means of bellows may be resorted to in the early stages and in subacute cases, and also hydrogen gas by Senn's method for intestinal wounds.<sup>1</sup> Mr. R. Clement Lucas<sup>2</sup> considers air much safer than

<sup>1</sup> Jour. Amer. Med. Assoc., June 23, 1888.

<sup>2</sup> Lancet, 1886, i. 96.

water, which latter he thinks gives too much lateral pressure and is too heavy, and is therefore much more liable to cause rupture of the intestinal walls. He makes the point, also, that the large quantity of water thrown into the bowel is likely to produce subsequent diarrhoea. It must be borne in mind that the gut is always in a weakened state, and it may be gangrenous even at an early period, if the constriction is great; much force, therefore, may readily cause rupture of its wall, and escape of its contents into the peritoneal cavity, with certain death as a result. Hence air, like water, must be injected gently and gradually.

Mr. Harrison Cripps (*loc. cit.*) gives an account of the dangers of forcible distention of the gut after it has been weakened by inflammatory action. A child eighteen months old had for four or five days been ill with symptoms of intussusception. Injections of water with a Higginson's syringe were made in an attempt at reduction of the invagination, and considerable force in the stream of water from the syringe was used. Suddenly the child was seen to become faint, collapsed, and died in three or four minutes. The post-mortem examination showed that the intussusception was firmly held together by the inflammatory exudate, and a rent several inches long had been made in the gut by the forcible current of water.

Many methods have been used, and still more suggested, to reduce the invagination, some of which may only be mentioned to be condemned.

Oil has been used as an injection, and may be of service.

Carbonic acid gas, made by introducing the alkali and the acid of a Seidlitz powder separately and allowing the evolution of the gas to take place in the bowel, has been suggested. This should be condemned for the danger which such an uncertain force could give rise to. A siphon of soda or seltzer has been used by Forest and others with good effect.<sup>1</sup>

Metallic mercury, allowed to run by gravity through a rectal tube, has been used, and it has also been given by the mouth, in the hope of overcoming the obstruction. The good which has been claimed for this method of treatment is due to the fact that the mercury when given by the mouth becomes divided into very fine globules, which might work their way through the obstruction, rather than to the weight of the mercury itself.

Success in the reduction of acute invaginations by the injection of water or of air can be expected only within the first forty-eight hours, for, although it has been successful later in the disease, the dangers of rupture of the intestine increase in exact proportion to the number of hours which have elapsed since the invagination occurred.

If these measures are of no avail, we must recollect that the invaginated bowel is every hour becoming more difficult to deal with and the danger rapidly increasing. The circulation is becoming more and more impeded, the congestion greater, and the peritonitis more intense. Lymph is being thrown out rapidly, which will glue together the coats of the bowel involved

---

<sup>1</sup> *Loc. cit.*

in the invagination and soon make reduction by direct manipulation impossible. To quote Mr. R. Clement Lucas again,<sup>1</sup> "To hesitate, dally, postpone, is to trifle with nature;" and we must proceed at once to open the abdominal cavity, search for the invagination, and, if possible, by manual efforts accomplish its reduction.

In chronic invaginations injections of water, and inflation with air by the bellows, have a good chance of success. Purgatives do great harm, as they only tend to hasten peristalsis and strangulation, with its grave consequences. In this (the chronic) form of invagination we have the greatest chance of success from laparotomy, as strangulation has not occurred, and the gut is not softened nor firmly bound by the lymph which in acute cases is always present.

The question of laparotomy in children for acute intussusception is one upon which much has been written, both *pro* and *con*. The published statistics are far from encouraging, for children bear very badly the shock of opening the abdominal cavity. But when we consider the absolutely hopeless condition if the remedial measures already suggested have been tried and have failed, and the cases recorded of complete recovery even in children as young as six months of age,<sup>2</sup> we ought not to hesitate, but should at once proceed with the operation.

**Laparotomy.**—The room in which the operation is to be performed must be warm—at least 75° F., and better 80° F.—and well lighted. Eight or ten bottles filled with hot water should be laid around the little patient, so as to prevent shock as much as possible.

If there be much abdominal distention, with rapid respiration, due, in part at least, to pressure against the diaphragm by the distended coils of intestine, it is best to wash out the stomach with warm water before giving an anæsthetic. This can be accomplished, if the child is old enough to do so, by getting it to drink warm water and then vomit, repeating this several times; or a small rubber tube can be passed into the stomach and its cavity thoroughly siphoned out. This will greatly relieve the abdominal distention and respiratory distress, thus diminishing the risk of the anæsthetic. Mr. Greig Smith<sup>3</sup> makes such a point of this that, with adults at least, he much prefers local anæsthesia by cocaine, or no anæsthesia at all, in all cases of meteorism, and thinks the dangers of increased shock much less than the dangers consequent upon the administration of the anæsthetic itself with the gaseous distention unrelieved. Chloroform carefully administered and well mixed with air is to be preferred.

The instruments necessary are those required for an ordinary laparotomy: a scalpel, half a dozen hæmostatic forceps, a grooved director, scissors, catgut and fine silk for ligatures and sutures, Hagedorn needles and a needle-holder, some fine cambric needles and fine sewing-silk for suturing

<sup>1</sup> Lancet, 1886, i. 98.

<sup>2</sup> Abdominal Surgery, p. 424.

<sup>3</sup> Sands, New York Medical Times, June, 1877.

the gut if it should be opened or have to be otherwise operated upon, with one or two sponge-holders or long hæmostatic forceps to be used as such. They must all have been boiled for at least ten minutes, and then placed in a five-per-cent. solution of carbolic acid. All instruments, needles, and sponges must be counted before the operation, and again immediately before the abdominal wound is closed. Just before the operator begins his incision they should be taken out of the solution and placed in hot, boiled, filtered water. In this way they are rendered thoroughly aseptic, and yet there will be no danger of irritating the skin of the hands or of introducing any of the carbolic acid into the abdominal cavity, which is not well borne by children. It is well to have in readiness, also, some of Prof. Senn's bone plates, or, what are more convenient, Dr. Robert Abbe's catgut rings of small size, or Brokaw's rubber rings, to be used if necessity arise for resection of the gut.

Several ordinary surgical sponges and two or three moderately large flat ones must be in readiness, as well as plenty of hot water which has been boiled and filtered. A fountain syringe with glass nozzle, for flushing the abdominal cavity, is also needed; or, if this be not at hand, a small pitcher with a rather sharply pointed lip will answer the purpose very well.

Plenty of corrosive-sublimate gauze will be required, not only for the purpose of dressing the wound, but also, if the operation be done suddenly, to be used in place of the towels wrung out of corrosive-sublimate solution so generally used at laparotomies to surround the field of operation. These wet towels materially increase the dangers of the operation, for young children cannot withstand the shock of the disease and the additional shock of the operation unless they are both dry and warm. The child must therefore be wrapped in warm dry blankets, and be surrounded by the hot-water bottles already mentioned, and there should be as little exposure of bare skin as possible. If time allows of such preparation, the field of operation may be covered, as for some years has been my own custom in all operations, by towels which have been wrung out of a one to one-thousand corrosive-sublimate solution a few hours before the operation and rough-dried in a clean room.

When the child is thoroughly under the influence of the chloroform, it is placed on a table in a good light, with its head not too high; with little children no pillow whatever should be used. Next the skin of the abdomen must be thoroughly scrubbed with soap-and-water with a nail-brush, then with ether to remove all grease, and finally with a one to four-thousand solution of corrosive sublimate. This for very young children is quite strong enough as a germicide: stronger would be likely to blister the skin.

The hands and forearms of the operator and assistants—of whom he ought to have three, one to give the chloroform, one to assist him with the wound, and one to attend to the sponges—must have been rendered thoroughly aseptic with nail-brush, soap, water, alcohol, and a one to one-thousand solution of corrosive sublimate.

The urine must be drawn by catheter if it has not been passed immediately before. An incision sufficiently long to admit two fingers should be made in the linea alba midway between the umbilicus and the pubes, for this gives the best command over the whole abdominal cavity. The tissues should be rapidly dissected down to the peritoneum, and all bleeding points secured. The peritoneum should then be caught up between two pairs of forceps and opened.

The greatest care must be exercised to prevent the escape from the abdominal cavity of the distended bowel, which now pushes itself into the incision, for experience has shown (and this is especially the case in children) that the dangers in laparotomy are increased in proportion to the amount of gut permitted outside the belly-walls. If, however, the gut is very much over-distended, thereby interfering with proper manipulation, a portion of it may be drawn outside the belly, and, after packing carefully around it flat sponges, so as to shut off completely all communication with the peritoneal cavity, an incision with a knife is made longitudinally, and the intestinal contents are allowed to escape. If this be done with a sharp knife, thus making a clear-cut wound, the distention can be relieved, and the wound rapidly closed with fine silk and a cambric needle by a continuous right-angle Lembert suture, without materially increasing the danger to the patient. A clean incision is much to be preferred to the introduction of a trocar and canula, as is so frequently advised, for the latter makes a ragged contused wound, very difficult to close securely. Puncturing the gut with a fine needle is also most unsatisfactory, as it does not permit of complete emptying of the contents and might allow of fecal extravasation. The greater the speed with which the operation can be performed (no undue haste, of course, being permitted), the better are the chances for ultimate success, as the shock is thereby greatly lessened.

As soon as the fingers are in the abdomen, search should be made for the cæcum, and, using this comparatively fixed point as a guide, the exploration should continue, inch by inch, in the direction of increased distention and congestion of the gut, until the intussusception is found. Often this is a matter of great difficulty, and it may be necessary to enlarge the incision before it can be accomplished.

When the tumor is found, attempts should be made at reduction with the parts *in situ*, as was successfully done by Dr. Snowball in a case reported by Mr. Workman;<sup>1</sup> but usually it will be necessary to draw the tumor outside the belly and pack around it flat sponges wrung out of hot boiled water, thus preventing further escape of gut and protecting the peritoneal cavity. If the condition of the gut is good and the amount of inflammatory lymph not too great, it should be taken in the fingers of the two hands, and, while with one hand gentle traction is made upon the entering portion, efforts should be made at the distal or ensheathing portion with the

<sup>1</sup> Lancet, 1888, ii. 888.

other hand to push the invagination backward and out. This is best accomplished by the same sort of movement as one would use in taking a ripe cherry between the fingers and pinching the stone out. In a recent case in which I operated, direct traction alone failed, but the combined manipulation above described released the invaginated portion in a few moments.

The mesentery is drawn in with the invaginated gut, and by its traction the tumor is curved to almost a semicircle, which makes it impossible by direct traction to withdraw the entering portion of the invagination.

The special point to be borne in mind in all ileo-cæcal invaginations—and it is with this variety that we have, of course, the most to do—is that our efforts at reduction must be persisted in, using gentle force, until the vermiform appendix appears, for until this is freely seen the reduction is not complete, but will immediately recur.

When the invagination is so firmly bound with inflammatory lymph that our efforts at reduction are unavailing, or when the inflammation has been so intense or the interval since the onset of the attack so long as to be followed by gangrene, an artificial anus should be made. To do this we must draw out the gut from the abdominal cavity until we find healthy tissue both above and below, the peritoneal cavity being carefully protected by hot sponges. The sound gut is then stitched with silk sutures to the external skin in an angle of the abdominal wound, and the gangrenous portion excised. The peritoneal cavity must then be thoroughly washed out with hot boiled water, and the angles of the wound closed.

An attempt at resection of the gut at this time in children is usually far from wise, as the shock of the operation added to the shock of the pathological condition is too great for them to withstand. We should, therefore, leave for a subsequent operation the re-establishment of the continuity of the intestinal canal.

#### INTERNAL STRANGULATION OR OBSTRUCTION OF THE BOWELS DUE TO CONSTRICTION.

Strangulation by *bands* (fibrous bands due to a previous peritonitis) are occasionally met with. They are generally due to intra-uterine peritonitis, for an inflammation of the peritoneum in young children is usually so violent that death quickly ensues,—too quickly for such bands to form. There is, however, a form of strangulation due to stricture of the gut following strangulated hernia. When a strangulated hernia has been inflamed and the bowels are glued together by an outpouring of lymph, this lymph, which is soft, may stretch by the continual pulling of the peristaltic action of the intestines, and become a fibrous band.

There are two methods by which strangulation by these bands may occur: either a knuckle of gut may pass under and be held down by the band, or a piece of gut may become twisted around the band; in both instances a violent muscular effort or strain might produce this. Adhesions

binding down the vermiform appendix, following an attack of perityphlitis, will cause a strangulation of the gut in the same way.

Sometimes, as the result of traumatic forces, a slit is torn in the mesentery, or through the diaphragm, of sufficient size to permit a knuckle of gut being forced in and constricted. This is an extremely rare condition, and especially so before the age of ten years.

In *Meckel's diverticulum* we have also another cause of strangulation. This diverticulum is an incomplete closure of the vitelline duct, and may extend as a tube, sometimes simply as a cord, from the umbilicus to the lower portion of the ileum. It is similar in structure to the small intestine. It generally comes off from the bowel as a blind tube, and the abdominal end opens into the lumen of the bowel. It has remained open as late as twenty years after birth, as a channel through which faeces pass to be discharged at the umbilicus. When a knuckle of gut is caught beneath this membranous cord, the circulation is completely cut off, and an acute strangulation results.

Mr. Pye-Smith<sup>1</sup> reports the case of a boy thirteen years old who had suffered from an acute intestinal obstruction for four days. He performed laparotomy, and the constricting band was Meckel's diverticulum attached at its extremity to the mesentery. The arrangement was peculiar. The diverticulum was a little over two inches in length. It came off from the bowel at almost a right angle between the mesenteric and free borders; it then passed through an opening in the mesentery of the part of the bowel from which it sprang, and closely encircled the bowel, immediately above its origin; its extremity was firmly attached to the mesentery, half an inch or more above the opening through which the diverticulum passed. Thus the constriction was not of a coil or knuckle of intestine, but of the tube at one level only, as if a cord had been tied around it at that spot. The bowels were moved spontaneously in twelve hours after the constriction was relieved, and a bit of fish-fin three-fourths of an inch long by one-fourth of an inch wide was passed. This had lodged above the constriction and precipitated the acute symptoms.

In tuberculosis the *mesenteric glands* may ulcerate and set up an inflammation by which the gut may become constricted. Likewise an acute localized *enteritis* may cause a narrowing of the lumen of the gut and consequent obstruction. Mr. Percy Potter<sup>2</sup> reports a case of this unusual form of obstruction affecting the ileo-caecal valve which came under his care at the Kensington Infirmary.

A girl five years old was admitted with intestinal obstruction of a week's duration. The countenance was pinched, the pulse small and weak, the abdomen flattened and especially tender over the right iliac region; the child lay on the left side, with the thighs flexed. She was restless; her tongue was brown and dry; the temperature was not increased; vomiting had been frequent, and was then persistent, but not fecal.

Palliative measures failed, and laparotomy was done. The intestines were exposed and traced from the duodenum downward; this and the first part of the jejunum were distended with flatus, whilst chyme was felt to be present in the lower part of the small intestine. The large bowel was empty. There were no signs of peritonitis, old or recent; the abdom-

<sup>1</sup> Lancet, 1889, i. 472.

<sup>2</sup> British Medical Journal, 1888, ii. 1045.



inal contents, so far as could be seen, were healthy. Objective signs of obstruction were absent. The child died from collapse six hours after the operation.

The post-mortem examination, made seventeen hours after death, showed no signs of commencing peritonitis, and all the organs of the chest and abdomen were apparently normal. The intestines were removed and filled with water, and it was found that the ileo-cæcal valve was impervious; no fluid entered the lower bowel. The last few inches of the ileum were found to be the seat of enteritis; flakes of inflammatory lymph had agglutinated the edges of the valve to such an extent that only a pin-hole remained, through which water could percolate drop by drop. No foreign body existed in the vermiform appendix, nor was anything found in the intestines to cause inflammation. The obstruction was centred solely in the interior of the bowel.

**Prognosis and Treatment.**—The prognosis in acute intestinal obstruction due to bands, Meckel's diverticula, and to internal hernia through apertures in the mesentery, unless the condition is relieved by surgical means, is absolutely fatal. Palliative medical measures are worse than useless, as valuable time is thereby lost, the strength of the patient diminished, and inflammatory changes in the constricted gut needlessly increased.

As soon as a diagnosis is made, the belly must be opened, the constricting band searched for, and the gut released. All the precautions and details mentioned in describing laparotomy for intussusception must be observed.

When the constricting band is found, a ligature is to be applied to both ends of the band and the intervening portion cut away.

If the constriction be a Meckel's diverticulum, the distal end must be freed from its attachments, the intestinal end brought outside the belly, the peritoneum being carefully protected by warm aseptic sponges, and the diverticulum cut away. The cut end must then be inverted, and the peritoneal surfaces of the stump so formed brought together by a continuous Lembert suture of fine silk and a cambric needle, completely shutting off the interior of the tube. It is then to be carefully cleansed by a one to four-thousand solution of bichloride of mercury, washed again with boiled water, and returned to the abdominal cavity, which is then to be flushed with warm boiled water, and the external wound closed. If there be any uncertainty as to the absolute closure of the cut ends, it will be better to introduce a drainage-tube and allow it to remain for twenty-four hours. This tube should be of glass, with fenestræ, and passed through a hole in a sheet of disinfected "rubber dam," and the dressing applied around the end of the tube. The sheet of rubber is then to be gathered up, a mass of gauze put in its opening, and pinned securely. This mass of gauze must be examined every two hours, and as soon as it is stained by the discharge it must be renewed. If the temperature rises above 100° F. the abdominal cavity must be flushed out with warm boiled water at intervals of four or five hours.

If the constricting factor is found to be a slit in the mesentery or diaphragm, the gut must be released, a stitch of catgut passed through the sides of the opening, and an attempt made to close it.

No mention has been made in this article of obstruction due to faecal impaction, as this subject and its treatment are fully considered in another portion of the work, and need no further mention here.

**Diagnosis.**—The differential diagnosis between the various forms of intestinal obstruction may be exceedingly difficult.

In obstruction by foreign bodies there is often a history of swallowing some substance, or of some great imprudence in diet, which will aid us; and occasionally the outlines of the obstructing mass may be felt by the hands through the abdominal walls, and followed on its downward journey.

With volvulus we have a history of digestive disturbance, sudden pain which is moderate at first and intermittent in character, and rapid and marked meteorism. There is moderate prostration, with tenderness almost at once of the abdomen. Vomiting also is not a distressing symptom.

In intussusception, by far the most common form with which we have to deal, there is the absence of a history of ill health; there is the sudden onset of pain; tenesmus, and vomiting which soon becomes faecal; the passage of blood-stained mucus from the bowel; a tumor in the abdomen, which is movable, and can frequently be detected by the finger introduced well into the rectum; and great prostration, with early collapse.

With obstruction due to constrictions the diagnosis is very difficult, and to determine the variety is frequently impossible. When the constriction is by bands, there will generally be a history of pelvic inflammation; when by slit or through an aperture, a history of injury. The onset of the attack is very acute; the pain is intense, continuous, and with exacerbations; vomiting begins early, is exceedingly urgent, and soon becomes faecal; while the prostration and collapse are very profound. There is no abdominal distention until later in the disease.

In order that the differential diagnosis may possibly be made clearer, the tabular statement on the following page is presented. Given a clear diagnosis, the question of surgical treatment becomes easy. It is in the diagnosis that the chief difficulty lies, and here is the greatest room for progress.

DIFFERENTIAL DIAGNOSIS.

FOREIGN BODIES.	VOLVULUS.	INTUSSUSCEPTION.	CONSTRICTIONS.
<p>History of swallowing foreign substance.</p> <p>Onset gradual.</p> <p>Pain is moderate, and increases only with the extending peritonitis.</p> <p>Prostration not so marked as in other obstructions.</p> <p>Tenderness of abdomen is early and rapidly increases, with tympanites.</p> <p>Vomiting is very late in coming on, and is never urgent.</p> <p>Constipation becomes absolute.</p> <p>Tenesmus is marked, especially if the obstruction be low down in the bowel.</p> <p>The foreign substance may sometimes be felt through the belly-wall and followed step by step downward.</p> <p>Foreign substance may sometimes be felt in the rectum.</p> <p>Prognosis is less grave than in other obstructions. Surgical measures must be used after medical measures fail.</p>	<p>Very rare.</p> <p>History of constipation and digestive disturbance.</p> <p>Onset sudden.</p> <p>Pain moderately severe at first, intermittent, and increases in severity.</p> <p>Prostration and collapse not very extreme.</p> <p>Tenderness of abdomen early, and gaseous distention extreme.</p> <p>Vomiting late, never urgent, and in a very small number of cases fecal.</p> <p>Constipation absolute, no discharge whatever from anus.</p> <p>No tenesmus.</p> <p>No tumor.</p> <p>Nothing by rectum.</p> <p>Death absolutely certain if unrelied by surgical means.</p>	<p>Most common.</p> <p>History of no moment.</p> <p>Onset very sudden.</p> <p>Pain acute, paroxysmal, wave-like, increasing and diminishing.</p> <p>Prostration and collapse extreme.</p> <p>Abdomen retracted; no distention; no tenderness at first, gentle pressure grateful.</p> <p>Vomiting from the first frequent and copious, and may be fecal.</p> <p>Faecal discharge if the intussusception be not too acute, an unloading of the bowel below the constriction.</p> <p>Tenesmus with discharge of blood-stained mucus from anus. (Important.)</p> <p>Tumor felt through abdominal walls. Tumor contracts beneath the hand during a paroxysm of pain, and changes its position, following the course of the colon.</p> <p>Finger in rectum will sometimes feel the end of the invagination.</p> <p>Prognosis always grave if unrelied by surgical means. Occasionally adhesions form between the entering and ensheathing layers, and the intussusception sloughs and comes away. This result is rare in children, and must never be expected under two years of age, and only in subacute cases.</p>	<p>Next in frequency to intussusception.</p> <p>History of injury, of peritonitis, or at least of pelvic pain.</p> <p>Onset very sudden.</p> <p>Pain very acute, continuous, but with exacerbations.</p> <p>Prostration and collapse extreme.</p> <p>No tenderness or abdominal distention until very late.</p> <p>Vomiting from the first very frequent and copious, and soon becomes fecal.</p> <p>Constipation absolute.</p> <p>No tenesmus.</p> <p>No tumor.</p> <p>Nothing by rectum.</p> <p>Prognosis absolutely fatal unless relieved by laparotomy.</p>

# PERITONITIS.

By HENRY ASHBY, M.D., M.R.C.P.

---

PERITONITIS occurs at all ages, and is due to a variety of causes: it occurs during intra-uterine life, in the newly-born, and during infancy and childhood.

During early life peritonitis cannot be said to be a common disease; the peritoneum appears to take on acute inflammation less readily than the serous membranes covering the lungs or the brain; and in comparing the frequency with which it occurs at different ages we must bear in mind that, in the adult, lesions of the ovaries, of the Fallopian tubes, and of the uterus more often give rise to peritonitis than any other cause. Before puberty a peritonitis resulting from these causes does not occur.

## INTRA-UTERINE PERITONITIS.

Many years ago the late Dr. Simpson,<sup>1</sup> of Edinburgh, called attention to the fact that in still-born children, or in fœtuses dying in the later months of intra-uterine life, a peritonitis was present which was evidently the cause of death. He further noted the fact that syphilis was frequently present. These observations have been confirmed since, and syphilitic lesions of other serous membranes, as meningitis and pleurisy, have also been found in still-born infants. Evidences of a prenatal peritonitis are not infrequently found after birth, in the form of adhesions and bands which connect the small intestines together, and in some cases constrictions or a narrowing of portions of the intestines have taken place as the result of cicatrization of bands and adhesions. In such cases death may result within a few days or a week of birth, with all the symptoms of intestinal obstruction. Such cases are not uncommon: a typical case is recorded by E. Owen,<sup>2</sup> in a newly-born infant, in which the ileum was constricted by old adhesions a few inches above the ileo-cæcal valve. Another case, in which the jejunum was constricted by old fœtal peritonitis, is recorded by Kirehner.<sup>3</sup>

---

<sup>1</sup> Edinburgh Medical and Surgical Journal, 1838, p. 490.

<sup>2</sup> Fœtal Peritonitis, Constriction of Ileum, etc., British Medical Journal, 1885, vol. i. p. 1201.

<sup>3</sup> Berlin. Klin. Wochenschrift, 1886, No. 27.

No symptoms, so far as is known, are present in fetal peritonitis; and if not fatal before birth, its results—that is, the adhesions which form—are exceedingly likely to lead to an interference with the development or to constriction of a portion of bowel.

#### PERITONITIS IN THE NEWLY-BORN.

Acute peritonitis in the newly-born is practically always septic, the result of unhealthy inflammation at the navel, or the absorption of septic material at this spot. It is uncommon in private practice, occurring in the large majority of instances in lying-in institutions. The infection is probably conveyed to the infant at the time the cord is tied, either by the fingers of the nurse or by the use of infected dressings. The early symptoms are usually those of a local inflammation, with erysipelatous redness around the attachment of the cord. There may be vomiting, diarrhoea, jaundice, distention of the abdomen, fever, and wasting. It must be remembered that peritonitis is only occasionally present in puerperal septicæmia of the newly-born. Indeed, according to Runge, it is not a common one, for of fifty-five post-mortems in infants dying of arteritis umbilicalis and septicæmia the result of puerperal infection, in only four was there peritonitis, pleuropneumonia being much more common. In puerperal peritonitis death mostly occurs within a week. The diagnosis is not difficult if evidence of inflammation about the navel be present. The treatment is almost entirely preventive.

#### PERITONITIS DURING INFANCY AND CHILDHOOD.

The peritoneum necessarily shares the fortunes of the organs which it surrounds, in this respect resembling other serous membranes, especially the pleura, taking on an acute inflammation in consequence of its close contact. It is also liable to acute inflammations which are primary, the result of some morbid state of the blood, as in Bright's disease or septicæmia, or are the result of injury. It is also liable to an acute—though more often a chronic—inflammation from the presence of tubercle. Acute peritonitis is sometimes “idiopathic,” or at least arises without any cause being traced either from contact with or a spreading from some neighboring inflammation: in such cases the inflammatory lesion has been attributed to a “chill” or to the “rheumatic” state of the system.

An acute general peritonitis which is secondary may follow as a consequence from perforation of the cæcal appendix or some inflammation around the cæcum, a perforation of the ileum in enteric fever, or a perforation of the diaphragm in a case of empyema. A general peritonitis will sometimes supervene in empyema without any perforation being present, the lymphatics being apparently the channel through which the inflammation spreads.

A primary or idiopathic general peritonitis without any local cause being discovered is not uncommon: it is needless to say that no case should

be referred to this category without a most searching post-mortem examination. Some of these cases are septic, there can be little doubt, though in what way the poison enters the system cannot be said. In some cases there is a history of a blow, perhaps contracted in the football- or cricket-field; in many cases, however, such blows are insufficient to explain the acute inflammation which has followed. In some cases the attack is in reality an entero-peritonitis, an enteritis or an acute intestinal catarrh being the starting-point. Certainly patches of intense congestion of the mucous membrane may be found in acute cases of peritonitis: it is not improbable that some animal poison or microbe may be taken into the alimentary canal and give rise to an enteritis which quickly involves the peritoneum.

An acute inflammation may be sero-fibrinous, or the fluid present may be pus; the inflammation may be general, or a circumscribed patch of lymph or an abscess may be present.

**Symptoms.**—The early symptoms of peritonitis may be interwoven with or supervene on those of some pre-existing lesion; or they may be modified in consequence of being secondary. There may be some diarrhoea, with pain and tenderness in the ileo-lumbar region, suggestive of a peri-cæcal inflammation; then suddenly collapse and continued vomiting point to a general acute inflammation. The symptoms of peritonitis may be indefinite for a while, the result, perhaps, of a suppurating mesenteric gland or local abscess, to be followed by those of an acute general peritonitis. A child may be suffering from scarlatinal nephritis, pass into more or less of a uræmic condition, then abdominal distention, pain, and tenderness may supervene as the result of a commencing peritonitis. In other cases the symptoms of peritonitis come on in the midst of robust health; in such cases the symptoms are apt to be acute, and the attack runs a more sthenic course than when it occurs secondarily, especially in one already exhausted by disease.

The classical symptoms of acute general peritonitis are vomiting, intense pain, tenderness and distention of the abdomen; the legs are drawn up; there is moderate feverishness, with a quick wiry pulse; constipation is the rule, but diarrhoea sometimes occurs; the countenance at first wears an anxious expression, later the patient becomes hollow-eyed and the face sunken, the pulse flags, the temperature falls, and death often comes suddenly at the last.

Vomiting is almost universally present; it is usually the first symptom, and continues all through the attack; it is always aggravated by food taken. In some cases the vomiting is so persistent—first the food taken being returned, then bile, and the semi-fæcal contents of the small intestines—as to suggest some strangulation or at least some mechanical obstruction of the bowel. The abdomen is rounded and tense, in consequence of the paralytic intestines being distended with gas; the diaphragm is raised and the breathing intercostal; the amount of pain and tenderness may be trifling, especially if the patient is seen for the first time after opium has been

given; in young children it is often exceedingly difficult to localize the tenderness, or, indeed, to satisfy one's self that there is any pain present.

The temperature varies, being perhaps  $101^{\circ}$ – $102^{\circ}$  F. during the first few days, falling to subnormal as collapse comes on and the heart's action fails. There may, however, be a high temperature ( $104^{\circ}$ – $105^{\circ}$  F.), or the temperature may be normal or subnormal from first to last. Purulent peritonitis may be present with a normal temperature.

The state of the bowels varies: constipation is usually present, but gas is generally passed per rectum freely. There may be complete obstruction, neither flatus nor fæces being passed, the case closely simulating a mechanical obstruction from strangulation of a piece of bowel. Diarrhœa may be present in the early stages or through the whole course; this is especially so when there is some irritation about the cæcum and in suppurative peritonitis.

The urine is mostly scanty, and often contains albumen.

The fatal event is frequently sudden, the heart appearing to fail. This may happen when the patient is being moved or attempts to sit up.

The mind is generally clear from first to last, though the patient is, of course, often drowsy, from the opium given; in a few cases active delirium is present, or the patient may simply wander at times.

The following cases may be taken as illustrating the primary form of peritonitis.

*Acute Suppurative Peritonitis.*—John C., aged seven years. The family history was good. He had been a strong boy up to the time of his fatal illness. No cause could be assigned for his sickness. Four days before admission to hospital he complained of pain in the "stomach;" there was vomiting and constipation. On admission to hospital on the fifth day of his illness, the face wore an anxious expression, as if he was in pain; the abdomen was distended and tense, and tympanitic and tender to the least touch; his legs were drawn up; he constantly vomited dark, sour-smelling, almost faecal stuff. The urine drawn off by a catheter contained albumen. All food and drink by the mouth were stopped, and he was given ten-minim doses of tinct. opii every second hour till three doses had been given. He passed a restless night, yet was drowsy from the effects of the opium. He gradually sank, dying on the evening of the sixth day of his illness. At the post-mortem, on opening the abdomen a few ounces of offensive pus escaped; the surface of the intestines was injected; the bowels were matted together with lymph; there was no strangulation. The cæcum and vermiform appendix were normal; there were patches of intense congestion on the mucous surface of the ileum, and a sharply-cut ulcer (not perforating), half an inch in diameter, some two feet above the cæcum. No certain cause for the acute peritonitis was found, unless it be assumed—which is indeed not improbable—that an enteritis existed in the first instance and that the peritonitis was secondary.

In the following case the symptoms closely resembled acute obstruction

of the bowels from strangulation. John C., aged nine years, was in good health up to February 9, when he was injured by a blow in the abdomen, but the injury does not seem to have been very severe. He complained of pain in the belly and vomited the same evening. He continued to vomit five or six times a day till his admission to hospital (under Dr. Hutton) on the fifth day of his illness. He had passed nothing per rectum except a small stool after an enema, and it was supposed he was suffering from an intussusception. On admission, his face was flushed, the eyes sunken; the abdomen was intensely distended, the coils of distended intestines being plainly seen; he complained of paroxysms of pain in the abdomen. He vomited faecal matter shortly after admission. There was pain on deep palpation in the right iliac fossa, but no marked tenderness. Full doses of opium were given. The next day (the sixth of his illness) it was thought advisable to make an exploratory opening into the abdomen (which was done by Mr. Wright): the intestines were deeply colored and matted together with lymph; no constricting band or invagination was detected; the wound was closed and a drainage-tube inserted. The boy gradually sank, and died suddenly the following day. At the post-mortem a general acute peritonitis was found; no cause was found, after a careful search.

In the following case, related by Sanné,<sup>1</sup> acute peritonitis was accompanied by diarrhoea. A boy of fourteen years, who had always enjoyed good health, was seized with shivering and headache. On the third day he had diarrhoea and pain in the abdomen, followed by vomiting, distention of the abdomen, and great tenderness; the vomiting continued, so that not only bile but also the contents of the small intestine were ejected. Death took place on the fourth day. At the autopsy a general sero-purulent peritonitis was found, without any other lesion.

Acute general peritonitis is not a common disease during infancy; Dr. West records a fatal case in an infant of seven months verified by a post-mortem; I have myself seen several such cases in children a little older, but have not been able to obtain post-mortems. In some of these cases the acute peritonitis is secondary to a suppurating mesenteric gland.

The symptoms are necessarily modified when the attack occurs in the course of other diseases or is the result of some local inflammation.

In the following case the peritonitis was secondary, occurring in the course of scarlatinal nephritis. Sarah W., aged eight years, was attacked with scarlet fever, the initial symptoms being vomiting, high fever, and rash. She was admitted to hospital on the third day; the tonsils were sloughy, there was much glandular enlargement, and high fever. The temperature varied from 100° to 101.6° F. till the twelfth day, when it reached 102.6° F. and a trace of albumen appeared in the urine; on the thirteenth day the temperature was 104° F., and only two hundred and fifty cubic centimetres of urine were passed; from the fourteenth to the sixteenth day the

---

<sup>1</sup> Barthez et Sanné, *Traité des Maladies des Enfants*, vol. ii. p. 621.



urine passed was only from seventy to one hundred cubic centimetres daily; urine contained fibrinous and epithelial casts; eighteenth day, vomiting, temperature 103° F., only seventy cubic centimetres of urine; nineteenth day, no urine passed, severe abdominal pain, respirations shallow and thoracic, abdomen distended and tense; twentieth day, temperature 98°–99° F., patient collapsed; twenty-first day, death. At the autopsy a general sero-purulent peritonitis was found; pleurisy of left lung; acute glomerular nephritis.

Peritonitis in association with or secondary to pleurisy or empyema occasionally occurs: the relation which one bears to the other is not always certain. Both appear at times to owe their origin to a septic state; in other cases the pleurisy or empyema may be of some standing when the peritonitis appears, and we are forced to admit that the peritonitis is secondary to the chest-mischief. In these cases there is no perforation of the diaphragm, the extension doubtless taking place through the lymphatics of the diaphragm. Burney Yeo records a case<sup>1</sup> of acute purulent peritonitis secondary to pleuro-pneumonia and whooping-cough in a boy of eleven years. Eustace Smith<sup>2</sup> and Maude<sup>3</sup> also record cases of acute peritonitis secondary to purulent collections in the chest in children eighteen months and seven years old respectively.

Peritonitis coming on in the course of other diseases or spreading from the chest usually runs a rapid course, and is almost universally fatal.

Traumatic peritonitis following a penetrating wound mostly runs a rapid course, and is quickly fatal. Thus, in a case recorded by Dr. J. H. Thompson,<sup>4</sup> a boy, as the result of an accident, ran the handle of a hammer into the rectum; he walked a mile to the Manchester Infirmary the same afternoon, but died suddenly of collapse at eight o'clock the next morning, sixteen hours after the accident. At the post-mortem it was found that the handle of the hammer had passed up the rectum and penetrated into the peritoneal cavity; there was injection of the vessels of the peritoneum, and much lymph.

A general peritonitis following tapping of a congenital hydrocele has been recorded.

*Perforative Peritonitis.*—The two commonest forms are ulceration and perforation of the cæcal appendix and perforation of the ileum in enteric fever; in rare cases perforation takes place during childhood, from a tubercular ulcer of the intestine, ulcer of the stomach, or perforation through the diaphragm. To the already existent symptoms are added those of sudden collapse, fall of temperature, vomiting, and acute abdominal pain. Death

<sup>1</sup> A Case of Infective Peritonitis following Pleuro-Pneumonia and Whooping-Cough, Brit. Med. Jour., 1878, vol. ii. p. 827.

<sup>2</sup> Disease in Children, p. 685.

<sup>3</sup> Empyema, Paracentesis, Death from Peritonitis, Med. Times and Gazette, 1885, vol. ii. p. 396.

<sup>4</sup> Lancet, December 7, 1887.

usually follows within forty-eight hours. This was the case with a girl of nine years,—perforation accompanied by a sudden fall in temperature on the evening of the fourteenth day; the temperature rose again in a few hours, death taking place forty-eight hours after the perforation. The autopsy revealed a perforation three inches from the cæcum, extravasated fæces, and general peritonitis.

*Circumscribed Peritonitis, Peritoneal Abscess.*—Instead of a general peritonitis taking place, a local circumscribed abscess may form, usually outside the peritoneal cavity, the pus eventually finding its way to the surface or opening into the intestine. The commonest cause of a peritoneal abscess is an inflammation around or perforation of the cæcal appendix; another not uncommon cause is suppuration of a mesenteric or retroperitoneal gland; abscesses may form in connection with tubercular peritonitis or ulceration of the ileum in tubercular disease. Abscesses in connection with the rectum, kidneys, or periosteum may involve the peritoneum. The symptoms of a local peritonitis closely resemble those of the acute general form, though they are rarely so severe or attended by collapse. There is local pain and tenderness, shivering, fever, mostly of the hectic type; there may be vomiting, but this is rarely so severe or continued as in the diffuse form. Sooner or later the local symptoms become accentuated; there is dulness on percussion over the seat of the abscess, a tumor or definite resistance may be detected on palpation, the skin becomes brawny and perhaps red, the veins on the abdominal surface are distended and tortuous. In case of a perityphlitic or appendix abscess the pus makes its way to the surface in the iliac fossa; in abscesses connected with the mesenteric glands, at the umbilicus.

The following may be taken as an example. A girl aged seven and a half years was seized with pain in the abdomen, feverishness, and vomiting; these symptoms continued for a fortnight, when she was admitted to hospital. At this time there was much pain and tenderness below the umbilicus, the abdomen was distended, temperature from  $100^{\circ}$  to  $102.8^{\circ}$  F. The next day the umbilical region was prominent, with a zone of redness; the skin gave way towards evening, and there was considerable discharge of pus. It continued to discharge pus (no faecal matter) till the thirty-third day, when she vomited, the tenderness and pain in the abdomen increased, temperature  $105^{\circ}$  F.; the child looked anxious and pale; the symptoms pointed to a general peritonitis. On the same day, after probing the fistulous opening, a small cheesy mass came away, followed by a free flow of pus and by relief of the symptoms. The fistulous opening closed on the forty-eighth day, and she was discharged well on the seventy-third day.

In another case, that of an infant, it was noticed by the medical attendant (Dr. Noble, of Kendal), a week or two after birth, that the abdomen was more rounded and distended than natural. When five weeks old, the abdomen was intensely distended, shiny, with enlarged veins on the surface and with redness and protrusion of the umbilicus; the abdomen was reso-

nant all over, and nothing could be felt on palpation. A few days later the skin at the umbilicus gave way and pus discharged freely. The infant a few days after died in convulsions. A large abscess-cavity was found at the autopsy, and caseous mesenteric glands.

**Prognosis.**—The prognosis in acute general peritonitis is always grave, recovery taking place in rare cases only. The more severe the symptoms the worse is the outlook, and when the patient has passed into the stage of collapse the case is well-nigh hopeless. Continuous vomiting, with complete obstruction of the bowels, is an exceedingly grave symptom. Diarrhea is of evil augury. Peritonitis from perforation of the bowel is nearly always fatal; symptoms of peritonitis coming on in the course of enteric fever or typhlitis ought to give rise to the greatest anxiety as to the result. No case is, however, hopeless, and occasionally a patient who seems moribund will rally and finally recover. The duration is rarely more than a week; it may be only a few days, or even less than forty-eight hours.

**Diagnosis.**—The diagnosis of a general acute peritonitis when all the classical symptoms are present is not usually a matter of difficulty. The early diagnosis may be a matter of great uncertainty, as well as the diagnosis in erratic cases. Unfortunately, when the diagnosis is uncertain our treatment is often not so decided as it would otherwise be. It is especially difficult in young children, in whom it may be impossible to localize pain, and in the presence or absence of any tenderness it may not be possible to determine whether peritonitis exists or not. Long-continued vomiting from any cause, whether gastric or cerebral, produces a condition closely resembling peritonitis, though there will usually be less abdominal tenderness and the abdomen will be less distended. While there is usually much pain and tenderness in peritonitis, they may be entirely absent, or the pain may be masked by the free use of opium. While in most cases the temperature is raised a few degrees in the first three or four days of the illness, it becomes subnormal before the end comes. It may, however, be normal from first to last, even though pus is present. It is the occasional absence of some of the more prominent symptoms that makes the diagnosis often so uncertain.

In the early stages of peritonitis, assuming that the symptoms come on when the child is in good health, the pain present may be thought to be due to flatulence or dyspepsia, and the vomiting to the same cause; the presence of fever would be of little value, inasmuch as fever is so often present in children suffering from dyspepsia. The diagnosis must depend upon the severity of the symptoms: if there is constant vomiting, fluids or solids being immediately rejected, paroxysms of sharp pains, great tenderness on pressure, peritonitis is almost certainly present. The difficulty, however, frequently arises from the impossibility of determining in a young child how much pain is present. The possible presence of indigestible food, obstruction of the bowels, or the passage of a gall-stone or renal calculus must be borne in mind.

The diagnosis between peritonitis and obstruction of the bowels from a strangulation or constricting band may be very difficult, as peritonitis often produces obstruction from the paralysis of the muscular coat of the bowel and a consequent distention and kinking. In peritonitis the vomiting is rarely fecal, and flatus may be passed per rectum; moreover, the temperature may be raised a degree or two.

Acute pleurisy, especially if it affect the diaphragm, or pleuro-pneumonia, may be mistaken for peritonitis, especially if the pain is referred to the hypochondriac regions. The presence of cough and quickened respiration and a careful examination of the chest would decide the diagnosis.

Hysterical conditions and rheumatic affections of the muscles of the abdominal wall may occur in older children and simulate peritonitis.

**Treatment.**—The treatment of peritonitis must largely depend upon the cause, but, unfortunately, we often have to treat our cases without knowing the exact anatomical condition which exists. As a result, we are often reduced to treating symptoms only, and perhaps have to regret, when too late, our want of courage, and to think that the patient has not had the chance that an operation would have given him; or we may perhaps believe that our meddling treatment has taken away from the patient his only chance. Thus, few would think that the proper treatment of a local peritonitis the result of inflammation or perforation of the cæcal appendix should be a purgative, while there can be little doubt that in traumatic or septic cases moderate purgation is useful, and that to lock up the bowels with opium from the first is a mistake.

Necessarily, the first step to treatment is diagnosis, and the history and symptoms must be most carefully gone into. In any case the preliminary steps are the same. The patient is, of course, put to bed; all food and drink by the mouth are stopped, the mouth being simply moistened with iced water. It cannot be too strongly insisted on that the distressing vomiting is certainly kept up by giving fluid or food by the mouth. Nutrient suppositories or small nutrient enemata may be given. Hot fomentations—as hot as they can be borne—should be applied over the whole abdomen, laudanum being freely sprinkled on the flannels before being applied. An ice-bag is preferred by some, but, as a rule, children resist its application. Shall we give a purgative? is a question we may not unlikely ask ourselves; the risks and the advantages alternately presenting themselves to our minds. The answer is not always easy; for it has been claimed, on the one hand, that purgation relieves the congested vessels and clears away irritating matters present in the bowels, while, on the other hand, if a local peritonitis is present around the cæcum or appendix, or there is a perforation of the bowel, a violent peristalsis is certainly risky. A Seidlitz powder or a dose of calomel is undoubtedly useful when vomiting and colicky pains are present, due to the presence of peccant matters in the bowels, or where an intestinal catarrh is present; but purgation is not to be thought of when there is local tenderness or the classical signs of

peritonitis are present. When there are constant vomiting, tenderness, intense pain, distended and paralyzed bowels, purgatives can do nothing but harm. Under these circumstances opium in sufficient quantity to relieve pain and render the patient slightly drowsy must be given. Two to five minims of tinct. opii or one to four grains of Dover's powder should be given, and repeated every four hours as may be required. In older children injections of from one-twelfth to one-sixth of a grain of morphia may be substituted.

In peritonitis due to perforation of the appendix or ileum, it is needless to say, neither purgative nor enema should be allowed, for fear of the results of peristaltic action.

Free stimulation with alcohol, in the form of champagne, brandy, or whiskey, must be resorted to; if the vomiting prevents their administration by the mouth they must be given by the bowel. In the later stages little else can be done in the way of drugs or general treatment.

As soon as the diagnosis of acute peritonitis is made, the question of laparotomy—*i.e.*, opening and draining the peritoneal cavity—will probably arise. There are some surgeons who are bold enough to regard laparotomy as a hopeful method of treating acute peritonitis, and who would advocate operation at the earliest stage, believing that washing out and draining the cavity is of the first importance. On the other hand, recovery has taken place in cases where operation was strongly urged by the surgeon in attendance, but refused by the friends; while in other cases operation has been quickly followed by collapse and death. The safest course to pursue, with our present experience, is to operate only in those cases where there is good reason to believe that pus is present, bearing in mind, however, the uncertainty of our means of diagnosis. If there is hectic fever, local dulness below the umbilicus, fluctuation, extreme tenderness and œdema of the abdominal wall, there can be no doubt that an operation is urgently called for. In such cases there is a fair prospect of success.<sup>1</sup> These cases, however, hardly belong to the category of acute general peritonitis, which usually ends fatally in five or six days, but rather to those which run a more or less subacute course. The chances of success are greater in the older than in younger children. A certain number of cases will occur where the diagnosis is uncertain and we are in doubt whether a purulent peritonitis or only lymph is present, whether the inflammation has spread from the cœcum or has been general from the first: in these an exploratory operation is justifiable and may at times be the means of saving life.

#### CHRONIC PERITONITIS.

Chronic peritonitis during early life, in the large majority of cases, is tubercular: it is by no means an uncommon affection. That simple chronic peritonitis does occur is certain, as a few fatal cases with post-mortems have

<sup>1</sup> See Keeley, *Lancet*, November 24, 1888, p. 1021.

been reported, but, as the disease may often go on to recovery in such cases, it may be impossible to say whether it has been tubercular or not.

It is difficult to say where the tubercular process originates; it may perhaps be primary in the peritoneum, but more likely may spread from a tubercular mesenteric gland or tubercular ulcer of the intestine. The presence of tubercles in the peritoneum gives rise to the effusion of lymph and serum; in some cases the one or the other is in excess. The effused lymph is slowly converted into fibroid tissue, which contracts, and consequently the great omentum becomes matted and the intestines perhaps adherent to one another. In the most severe cases the matting together of the abdominal organs is extreme, so that it is hardly possible to separate them without tearing; caseous masses and small abscesses are common. In advanced cases caseous mesenteric glands, and extensive tubercular ulcers of the intestines, as well as tuberculosis elsewhere, are associated with the chronic peritonitis.

The peritoneal covering and also the capsule of the liver and spleen become thickened. Perihepatitis as well as interstitial hepatitis may be present. In favorable cases the tubercular process comes to an end, the lymph becomes converted into fibroid tissue and lime salts are deposited; in other cases a chronic suppuration takes place and the liver and spleen become lardaceous. Occasionally the matting of the intestines gives rise to a strangulation or constriction of the bowels. The patient may succumb from a general tuberculosis.

**Symptoms.**—The early symptoms are usually ill defined. There is often a period of ill health, loss of appetite, coated tongue, feverishness at night, loss of flesh, abdominal pain, and attacks of diarrhoea. In children two or three years of age the ill health is generally referred to dyspepsia or intestinal catarrh. Perhaps the most significant symptom is diarrhoea, which comes in fits and starts, probably not severe, and consisting possibly of a chronic looseness of the bowels. Feverishness in the afternoon or at night with the looseness of bowels is especially significant. The abdomen is generally rounded, the small intestines being constantly distended with gas, the skin stretched and shiny. In the course of a few weeks, or perhaps longer, this distended state of the abdomen, with the fretful condition of the child, as well as his capricious appetite, excites the alarm of the friends. An examination at this time will perhaps reveal nothing but distended intestines, with very probably some enlarged veins on the surface and often a protrusion at the umbilicus. The abdomen is resonant all over, the distended bowels masking any fluid or any thickened omentum that may be present. Sooner or later, by careful palpation with the hand laid flat on the abdomen, more or less "lumpiness" will be felt, due to induration or matting of the omentum, and often more or less dulness may be detected on percussion, varying from time to time according to the amount of gaseous distention of the bowels. The percussion-note is a muffled resonance, such as would be expected from a thickened omentum backed up by dis-

tended viscera behind. The matting together of the intestines, with fluid held in the interstices between them, would naturally impair the normal tympanitic note. Frequently, perhaps usually, there is no pain on handling, or but little is complained of by the patient.

The further progress of the case is modified according to the rapidity with which the peritonitis progresses or the extension of the tubercular process elsewhere. Most of these cases are essentially chronic, lasting many months or even a year or two, and not infrequently ending in recovery. In other cases the patient becomes more and more anæmic, wasted, and flabby, the hectic fever is more pronounced, the diarrhœa more continuous and obstinate, and the patient gradually sinks, after perhaps having been reduced to a complete skeleton. On the other hand, it is by no means uncommon for tubercular meningitis to supervene and quickly bring the end.

In other cases chronic peritonitis assumes the form of a chronic ascites. After a period of more or less indefinite ill health, the abdomen is noticed by the friends to enlarge, the clothing no longer fits as it used to do, the child, if old enough to be up and about, has a peculiar gait on account of the abdominal enlargement, and a physical examination shows the presence of fluid in the peritoneal cavity. The fluid is perhaps free in the cavity, the intestines floating up when the child is in the supine position, giving a tympanitic note around the umbilicus, while there is dulness in the flanks; but with the patient on his side or on "all-fours" the lowest part gives a dull note, on account of the fluid gravitating there. In other cases there are the physical signs of matting of the omentum and intestines and also of the presence of fluid. The temperature may be normal during the whole of the twenty-four hours, there may be no wasting, and the child may appear perfectly well except for the ascites present; on the other hand, hectic, wasting, and diarrhœa are not uncommon. The case may end in recovery after many months, or, on the other hand, a more generalized tuberculosis may supervene. When recovery has taken place the fluid has been absorbed, and much of the induration disappears by a cicatrizing process.

**Complications.**—Tuberculosis of other abdominal organs is exceedingly common: probably in every case of tubercular peritonitis, sooner or later, other abdominal organs are affected,—the commonest being the mesenteric glands and the lymphoid glands of the intestines. A perihepatitis combined with an interstitial hepatitis sometimes takes place, and a consequent obstruction to the portal circulation. Tuberculosis of the spleen and testes is not uncommon. Tubercular meningitis or acute miliary tuberculosis is apt to supervene. Acute obstruction of the bowels may come on, or an abscess forms which probably points at the umbilicus.

**Diagnosis.**—The early diagnosis of tuberculosis of the peritoneum is difficult in most cases, or it is only a matter of suspicion until the physical signs of induration of the omentum or matting of the intestines or ascites

are present. When ascites alone is present, a diagnosis between ascites due to chronic peritonitis and ascites due to obstruction of the portal vein has to be made. Cirrhosis of the liver giving rise to portal obstruction is very rare during childhood, and so is portal obstruction due to adherent pericardium and mediastinitis. In any given case the chances are immensely in favor of chronic peritonitis: it must, however, not be forgotten that a perihepatitis and interstitial hepatitis secondary to chronic peritonitis may be present. The abdomen should be carefully examined by palpation and percussion, to discover the edge of the liver or any indurations: the temperature is often more or less of a hectic character in chronic peritonitis, though it may be normal. The diagnosis between simple and tubercular peritonitis is often impossible. Ascites due to cardiac disease is hardly likely to be mistaken for chronic peritonitis, as the physical signs of the heart-mischief would be present and the dropsy would usually begin first in the legs. It must be carefully borne in mind that in the early stages of chronic peritonitis the symptoms are those of a chronic intestinal catarrh, and we must not jump to the conclusion that a peritonitis exists, nor, on the other hand, put it definitely out of court.

**Prognosis.**—In all cases of tubercular peritonitis a cautious opinion as to the final result must be given. There is always the risk that extensive cascating mesenteric glands may supervene, or tubercular ulceration of the bowel, or a tubercular meningitis. It is curious, however, how comparatively rarely extensive tuberculosis of the lungs is present. The tendency of tubercular peritonitis is towards recovery, though the risks of an acute peritonitis supervening, or an acute or subacute tuberculosis elsewhere, are by no means remote. It is certain, however, that a large number of cases completely recover, adhesions between the various abdominal organs taking place. It is important to remember this tendency to recovery, when recoveries are reported after laparotomy and when it is assumed that the patient has been snatched from certain death. The more acute the case the more unfavorable the prognosis; wasting hectic, diarrhoea, and night-sweats point to an extended area of tuberculosis.

**Treatment.**—As the starting-point of a tubercular peritonitis is, in the large majority of cases, to be found in a catarrh of the bowels, it is in this direction that treatment must be commenced. The presence of a chronic catarrh of the bowels in a child disposed to tuberculosis is always a source of danger, the lymphatic glands and secondarily the peritoneum becoming the seat of tubercle. In all cases where the suspicions are aroused, no time should be lost in getting the child placed under the most favorable conditions as regards hygiene: pure country air and sunlight are above all things necessary, or the child should be sent to the sea-side. His diet and clothing of course require attention. He must necessarily be kept at rest, either in bed or on a couch; in summer he should be placed as much as possible in the open air. A flannel binder around the abdomen should always be worn. The diet must be plain, consisting of moderate quantities of under-



done chops; fish, fowl, and eggs can be taken; milk and cream, if they agree, should be given in moderate quantities; excess of starchy foods should be avoided, but toast and light ground-rice puddings may be given. Any tendency to diarrhoea will necessarily lead to a modification of the diet. Pain in the abdomen may be relieved by opium fomentations or belladonna applications; in the more chronic cases mild mercurial preparations, such as an ointment of the yellow oxide of mercury (twenty grains to the ounce), are useful. The medicines given must be those that assist digestive processes, such as acids and pepsin preparations, or those that are calculated to relieve the dyspepsia consequent on the intestinal catarrh, such as alkalies, bismuth, or vegetable bitters. Cod-liver oil and iodides are of value as tonics. If the fluid in the peritoneal cavity is excessive and shows little tendency to reabsorption, tapping should be performed, preference being given to a very small trocar and canula, the fluid being allowed to drain slowly away. If pus is present, incision and drainage should be resorted to, though in chronic tubercular suppurative peritonitis the prognosis is exceedingly grave. Recently laparotomy and washing out of the peritoneal cavity have been advocated by some surgeons as a routine treatment, and successful cases have been reported by Treves,<sup>1</sup> Lawford Knaggs, and Kelner Clarke; and the experience of these surgeons has gone far to show that the peritoneum in tubercular peritonitis is tolerant of surgical interference. In any case where hectic fever, local tenderness, and dulness suggest a collection of pus, an exploratory operation should be performed. In the more chronic cases, where the symptoms are not urgent and the child holds its own, it is wiser not to interfere, and in a fair proportion of cases recovery may be looked for.

---

<sup>1</sup> Lancet, November 5, 1887.

# PERITYPHLITIS, PARATYPHLITIS, PERITYPHLITIC ABSCESS.

BY CHRISTIAN FENGER, M.D.

---

## DEFINITION.

*Perityphlitis*, derived from *περί*, "around," and *τυφλόν έντερον*, the "blind intestine," strictly speaking means an inflammation of the serous lining of the cæcum. As, however, the peritoneal surfaces of adjacent organs are necessarily involved, the term is applied in a wider sense to local peritonitis in the region of the cæcum, that is, in the right iliac fossa. The term perityphlitis was first used by Puchelt in 1832, to designate inflammation in the right iliac fossa, which about that time had been brought prominently before the profession by the essays of Husson and Dance (1827) and Dupuytren, and which had thitherto been termed *tumores phlegmonosi fossæ iliacæ dextræ*, or abscess of the right iliac fossa.

The marked frequency with which the inflammation originates in the appendix made With (1879) propose to substitute the term appendicular peritonitis for perityphlitis. His idea was to emphasize, by the adjective "appendicular," the fact that the disease almost always originates in the appendix and not in the cæcum, and that the term perityphlitis is incorrect because it directs attention to the cæcum; he also wished to correct the inherited belief that the so-called stercoræal typhlitis, caused by accumulation of feces in the cæcum, plays a conspicuous part in the etiology of the disease. Fitz proposes the term appendicitis as more appropriate, since it designates the primary essential condition that precedes and leads to the peritonitis. The majority of authors still employ the term perityphlitis, although appendicular peritonitis and appendicitis are coming more and more into general use.

The character of the resulting inflammation differs with the varying rapidity of the destruction from within of the intestinal wall, and with the virulence and quantity of the microbes invading the peritoneum. A slow invasion of less virulent microbes, or invasion of the ptomaines alone, may cause only a local plastic peritonitis, terminating in adhesions between the opposing serous surfaces of the area involved, or *peritonitis appendicularis*

*plastica*, corresponding to plastic perityphlitis. If sufficient pus-microbes enter the peritoneum to make the local peritonitis terminate in suppuration, we have the perityphlitic abscess, a localized collection of pus, corresponding to the territory of the peritonitis, bounded by a line of adhesive peritonitis, which forms a barrier of connective tissue between the abscess and the general peritoneal cavity.

*Paratyphlitis* was introduced by Oppolzer in 1863 to designate the inflammation in the loose connective tissue behind the cæcum, in that portion supposed not to be covered with peritoneum. The name was formed in analogy with Virchow's distinction in case of organs partially covered with peritoneum, that the prefix "peri" should indicate inflammation in the peritoneum, and "para," inflammation in the tissue surrounding the portion of the organ not covered with peritoneum. Paratyphlitis, then, is a retro- and consequently extra-peritoneal inflammation behind the cæcum.

As a localization of general pyæmia, or extension of a puerperal parametritis, there is no reason why inflammation should occur oftener in one iliac fossa than in the other. When Oppolzer states that paratyphlitis often originates in the cæcum, it becomes doubtful, as will be shown later, whether the term paratyphlitis can be correctly used in this connection. Modern anatomical research tends to show that what has been described as paratyphlitis originating from the appendix or the cæcum is either a deep-seated local peritonitis—that is, perityphlitis behind the cæcum—or has at any rate commenced as such and has not until later invaded the retro-peritoneal tissue.

In conclusion, it may be said that the term perityphlitis, subdivided into an adhesive and a suppurative variety, is sufficient to designate adequately the local peritonitis originating in the appendix and cæcum.

#### HISTORY.

Dupuytren, as a result of observations made prior to 1820, first called attention to the connection between abscesses of the right iliac fossa and diseases of the cæcum, in clinical lectures at the Hôtel-Dieu. In 1827 Husson and Dance gave a more minute description of the disease. Perforation of the appendix as a cause of fatal peritonitis was first described by Louyer and Villermay in a contribution to the French Academy of Medicine in 1824. Within a decade the subject had attracted considerable attention, and many important contributions to its literature had been made. The excellent articles of John Burne in England, Albers and Puchelt in Germany, and Posthuma in Holland, and that of Stokes advocating the opium treatment, all threw more and more light on the pathology of the disease; but still the cæcum was believed, on account of the stercoreal typhlitis, to play the principal part, and the vermiform appendix, although Burne had already pointed out the frequency with which it was found diseased, was usually considered responsible for fatal diffuse peritonitis only. Later on, attention was called to the appendix by Toft and With, who

showed that perityphlitis is almost exclusively due to a primary disease in this organ, and that the cæcum is very rarely the primary seat of disease.

Text-books and hand-books on children's diseases treated very sparingly on this subject, although perityphlitis is usually met with in youth, and although cases in children had been on record from the earliest period (Iliff, 1832). Pepper and Meigs's hand-book of 1870 was the first treatise on diseases of children in which the subject was exhaustively treated. This was followed ten years later by the excellent article of Matterstock, in which still more attention was given to the peculiarities presented by the disease in early life.

Perityphlitis, although a Dupuytren wrote its history, has naturally, as an intra-abdominal disease, been almost exclusively in the domain of internal medicine. Surgical interference in abscesses of the iliac fossa was limited to those pointing under the skin, ready to open spontaneously. The writer on internal clinical medicine has studied its symptoms, and treated it with opium,—that is, left the pus to take its course; the pathologist has carefully pointed out all the details of the cause, course, and progress of the inflammation; but it has been left to the American surgeon to place suppurating perityphlitis where it properly belongs,—in the domain of surgery. Hancock in 1848 operated successfully upon an isolated case. His advocacy of the advantages of early operation, however, met with no encouragement.

Willard Parker, of New York, first proved, in 1867, that early operation would save three out of four patients. The surgeons of this country and abroad have followed Parker with a degree of success which has brought the disease into another field and raised many questions of detail not hitherto regarded, showing conclusively that up to that time the subject had received much more attention from the American profession than from the profession abroad. Dr. R. F. Noyes in 1883 published a masterly article on the operative treatment of the disease, with a report of one hundred operations, of which ninety per cent. were from America. Fitz has contributed an excellent, exhaustive, and timely article, treating mainly of pathology and statistics. The anatomical details have received the special attention of Ransohoff, in his interesting and scholarly paper of 1888. The brilliant results of early operation by McMurtry and Sands in 1888 have made laparotomy a justifiable procedure in certain forms of the disease.

#### ETIOLOGY.

Arrest of fecal matter, with consequent invasion of inflammatory microbes, being the principal cause of the lesions in the intestinal wall, the first question that presents itself is, what anatomical peculiarities make this part of the intestinal canal the seat of the lesion? Dupuytren has already directed attention to the analogy in frequency between perityphlitic abscess and perirectal abscess or anal fistula. In fact, if the rectum were an intra-peritoneal intestine, anal abscess would be as fatal as perityphlitis now is.

The anatomical points in the cæcum and appendix, therefore, deserve notice. The cæcum in man is a rudimentary organ, commencing in the fifth or sixth week of embryonal life as a blind branch of the intestine, but later differentiating into a distal, narrow, longer portion, the appendix, and a proximal but wider portion, the cæcum. It is constructed on the type of the large intestine, and remains rudimentary in the carnivora and man, while in herbivorous animals it forms a large, functionally important portion of the intestinal tract, and is constructed on the plan of the small intestine. Towards the end of foetal life the three ampullæ or sacculi of the cæcum are formed by development of the three longitudinal bands of muscular fibres, the *tæniæ coli*. By the enlargement of the right anterior sac, the conical shape of the cæcum is changed to its later more tetragonal form. The apex is turned more and more to the left, until at last it is close to the ileo-cæcal junction. The appendix now lies on the posterior medial side of the cæcum, partially concealed behind it (Ransohoff).

The length and breadth of the appendix at different ages have been studied by Toft. In thirty-five specimens of the appendix at the ninth month of foetal life, equivalent to the time of birth, the average length was four and one-half centimetres, the circumference at the upper funnel-shaped portion nine millimetres and at the lower cylindrical portion six millimetres. In children of ten months the appendix was five centimetres long, and ten millimetres and eight millimetres in circumference at the upper and the lower portion respectively. In the fourth year it was six centimetres long and ten millimetres in circumference, and in the seventh year it was seven centimetres long and ten millimetres in circumference, while in adults it is ten centimetres long and thirteen millimetres in circumference; thus showing that the appendix is comparatively longer and wider in children than in adults.

The mucous membrane of the cæcum and appendix is analogous to that of the colon, proving their physiological action to be that of absorption, favoring inspissation of the faecal matter and the formation of firmer faecal concretions. The mucous membrane at the entrance of the appendix forms the valve described by Gerlach, which is usually developed between the ages of three and twelve years. Ransohoff found that this valve prevented injections into the cæcum from entering the appendix, which it seems is in this way to a great extent protected from the invasion of small foreign bodies. He describes a peculiar arrangement of the mucous folds of the cæcum surrounding the orifice as in a vortex, towards which there would be a natural current of the contents of the cæcum. In this way he explains why long, narrow bodies longer than the diameter of the orifice, as pins, needles, and nails, are found in the appendix.

The question of the relation of the peritoneum to the appendix and cæcum is a most important one. The appendix has an entire peritoneal covering, and a mesentery, the so-called mesenteriolum, the length of which determines the mobility of the appendix. A fold in this mesenteriolum

forms the ileo-cæcal fossa of Luschka. When extensive inflammation from within outward, or perforation of the appendix, takes place, peritonitis must necessarily follow. Until recently the cæcum was described as being covered with peritoneum on its anterior and lateral aspects, but having, as a rule, a portion of its posterior surface buried in the loose retro-peritoneal tissue. Perforation in this place would not directly involve the peritoneum, but would cause the paratyphlitis of Oppolzer and other authors. Although anatomists like Luschka and Hyrtl insisted that the cæcum was covered all over with peritoneum, and even that the lower portion of the ascending colon often had a mesentery, a fact well known to surgeons in cases of hernia, it was left to Treves and Ransohoff to settle the question decisively. Treves never saw the cæcum without a mesentery, and Ransohoff after the examination of sixty-three bodies found the posterior surface of the cæcum not covered with peritoneum in only two cases. He is consequently right in stating that a retro-cæcal extra-peritoneal inflammation, a paratyphlitis, is an anatomical impossibility, for any inflammation extending from within outward, either of the cæcum or of the appendix, must cause an intra-peritoneal inflammation,—a peritonitis.

The location of the cæcum and appendix on the psoas muscle, above the inner portion of Poupart's ligament, varies according to the length of their mesenteries; in eighteen per cent. they may be found in the pelvis minor (Ransohoff). Kraussold points out that he has found the appendix in other than its usual position,—viz., behind the cæcum and the ileum, on the right or lower side of the mesentery. He has often found it along the right border of the ascending colon, point upward; sometimes down over the pelvic border or extending from behind around the ileum at its junction with the cæcum. The various positions of the appendix would tend to determine the seat of a local appendicular peritonitis, and should be taken into consideration in making the diagnosis.

The frequency with which the disease occurs in children has been noted by Demme. In a total of one hundred and twenty-seven patients from the Children's Hospital and Polyklinik in Bern there were thirty-six cases of pronounced perityphlitis, in only nine of which coprostasis caused the disease. It is well known that males are much more subject to the disease than females. Fitz out of two hundred and forty-seven cases of children and adults found the disease in eighty per cent. of males and twenty per cent. of females. Matterstock in seventy-two cases of children found the disease in fifty-one males, or seventy and four-fifths per cent., and in twenty-one females, or twenty-nine and one-fifth per cent.

The following extensive statistics of Fitz and Matterstock show that perityphlitis is most common between the ages of ten and thirty. Between thirty and forty it is a little more frequent than from birth to ten, when it is about ten per cent.

AGE.	MATTERSTOCK.		FITZ.		
	Perityphlitis, 474 cases.		Appendicitis, 228 cases.		Perityphlitis, 178 cases.
0-10 years . . .	46 cases, 9.7 per cent.		22 cases, 9.6 per cent.		10 cases, 5.6 per cent.
11-20 " . . .	143	30.1	86	37.7	53
21-30 " . . .	158	33.3	65	28.5	53
31-40 " . . .	72	15.2	34	14.9	25
41-50 " . . .	30	6.3	8	3.5	18
51-60 " . . .	18	3.8	11	4.8	10
61-70 " . . .	5	1	1 case,	0.4	7
71-80 " . . .	2	0.4	1	0.4	2

We have from Matterstock, in seventy-two out of his total of four hundred and seventy-four cases, statistics of the disease in children up to fifteen years of age.

The ages of the children were as follows :

AGE.	BOYS.	GIRLS.	TOTALS.	AGE.	BOYS.	GIRLS.	TOTALS.
7 months . . . . .	1	..	1	8 years . . . . .	4	1	5
20 " . . . . .	1	..	1	9 " . . . . .	5	3	8
2 years . . . . .	..	..	..	10 " . . . . .	2	1	3
3 " . . . . .	2	2	4	11 " . . . . .	5	3	8
4 " . . . . .	2	..	2	12 " . . . . .	6	2	8
5 " . . . . .	3	1	4	13 " . . . . .	6	1	7
6 " . . . . .	..	3	3	14 " . . . . .	5	1	6
7 " . . . . .	6	..	6	15 " . . . . .	3	3	6

In very young children the disease is rare, and isolated cases only are on record. The youngest I have found was reported by Demme. A girl seven weeks old was fed after the seventh day upon porridge. In the third week she became restless, and was given more porridge. In the beginning of the seventh week high fever, tympanites, and tenderness in the caecal region were noticed, quickly followed by peritonitis and death. The autopsy showed diffuse peritonitis, most pronounced in the caecal region. The appendix was dilated and filled with adherent, firm, solid, concrete-like faecal masses. On microscopical examination these were shown to be a conglomerate of undigested porridge. Perforation of the appendix was not found. Matterstock mentions the case of a boy seven months old; Silbermann, a case of peritonitis in the late period of lactation, caused by perityphlitis following long-continued constipation. Matterstock and Fitz each report a case in a child of twenty months. From the third year the disease becomes more common.

**Faecal Concretions.**—Mechanical injury to the mucous surface of the appendix and the caecum from faecal concretions plays the most conspicuous part in the etiology of the disease. Faecal concretions are much more commonly found than foreign bodies. Matterstock has collected one hundred and forty-six cases of perforation of the appendix: in sixty-three cases

faecal concretions were found, in nine cases foreign bodies; in eight cases nothing was found, and in the remainder no cause was reported. In forty-nine cases of death from perityphlitis in children, perforations were found thirty-seven times. In twenty-seven cases concretions were found; in three, foreign bodies; in six, nothing at all, in spite of thorough investigation. Fitz found in one hundred and fifty-two cases, of children and adults, faecal masses in forty-seven per cent. and foreign bodies in twelve per cent. Hagen attaches more importance to foreign bodies, as he observed in his cases of perforation of the appendix sixty-nine and one-half per cent. of faecal concretions and thirty and one-half per cent. of foreign bodies.

In the appendix are found single or multiple, soft or hard, moulded masses of faecal matter, cylindrical, with pointed ends, rarely containing a nucleus of a foreign body, as a fruit-seed, hair, bristle, etc., causing corresponding single or multiple perforations. The softer masses are normal inspissated faecal matter, which may, however, be easily crushed between the fingers. The harder masses often have concentric layers of different colors, containing, as Albers has stated, phosphate of calcium. The same constituent was found by Smith, mixed with a small amount of carbonate of calcium. Roger, in the case of a child five years old, found diffuse peritonitis, the appendix enlarged to three times its normal size, and in its middle two perforations from two enteroliths the size of a cherry-stone, which upon examination were found to contain organic salts of the bile, and a little phosphate and carbonate of lime and magnesium, with no foreign body as a nucleus. Sands, in operating on a boy of three, found three faecal concretions: one, nearly spherical, about a quarter of an inch in diameter, lay free in the peritoneal cavity, a second had partly escaped from an opening in the appendix and was picked out with forceps, whereupon the third one dropped from the opening.

Cæcal stones (Albers) are exceedingly rare; they are larger,—of the size of a walnut or a hen's egg,—and often have as a nucleus a foreign body, such as a piece of potato-peel or cabbage (seldom a gall-stone), surrounded by a shell of calcareous matter or triple phosphates. They generally cause obstruction of the bowel, with symptoms of ileus. Albers mentions a case of a boy of ten who, after measles, had pain in the cæcal region, and died with the symptoms of obstruction. A calcareous concretion at the ileo-cæcal valve was found to have caused the stenosis, without perforating the bowel. Bourdon observed perforation and fatal peritonitis caused by a similar concretion of hard, clay-like faecal matter. These cæcal stones may become detached and pass by the rectum, or may after perforation be evacuated through the abscess. Habershon found in the museum of Guy's Hospital a large calculus, the size of a hen's egg, which had been removed from a sinus leading down to the cæcum (Bartholow).

**Foreign Bodies.**—A great variety of foreign bodies has been found, either as such, or often forming the nucleus of a faecal concretion: fruit-stones (cherry-stones), in a five-year-old boy; ascaris, in a three-and-a-half-



year-old girl (Matterstock); hairs, from the centre of a faecal concretion (Hagen); orange-seed, in an eleven-year-old girl (Savior.) Grape-seeds and a lima bean (Bartholow) were evacuated with pus from abscesses in adults. A shirt-button (Demme) caused a perityphlitic abscess which opened into the rectum; the button was evacuated, and the child recovered. Bossard found it difficult to put cherry-stones into the appendix. How soon after its introduction into the alimentary canal a foreign body may cause perforation has been noted in some cases. Savior states that the orange which furnished the seed perforating the appendix in the case above mentioned was eaten eight days before the beginning of the disease. Demme saw a girl seven years old who had swallowed a number of glass beads, the size of a pea, seventeen to twenty days before the beginning of the perityphlitis. This apparently subsided in two weeks, but a relapse occurred three weeks later, with formation of an abscess in the ileo-cæcal region. Upon incision, pus and three glass beads escaped. The girl recovered. At autopsies foreign bodies are often accidentally found in the appendix, which have caused no apparent injury to the intestine. In Gerhardt's clinic in Jena a lead button was found in the appendix of a boy seventeen months old; Jadelot found four ascarides in the healthy appendix of a boy thirteen years old.

**Ulcers.**—Tuberculous and typhoid ulcers are rarely the cause of perityphlitis, as compared with the general frequency of the diseases. Fitz reports only eight cases of tuberculous and three of typhoid ulcers. Dysenteric ulcers are still more rarely found (Birch-Hirschfeld).

**Traumatism.**—Mechanical injuries to the ileo-cæcal region or the abdomen are rarely reported as causing perityphlitis. Cushing saw a case of an eight-year-old boy, previously healthy, whose playmates threw him down in a ditch and put stones on his stomach. He was in bed one day, at school again in three days, and received another injury while playing. Symptoms of peritonitis were seen fourteen days after the first injury. Median laparotomy was performed, with evacuation of a pint of fetid pus; death occurred next day. The autopsy revealed a perforated appendix containing a faecal concretion in an abscess-cavity, surrounded by firm adhesions which, by giving way at one place, caused communication with the general peritoneal cavity. Homans observed perforation in a girl of eight after a fall; Maisch, in a seven-year-old boy after a kick in the abdomen; Amyot, in a nine-year-old boy after a long wagon-ride; Buehner, in an eleven-year-old boy; and Patterson, in a fourteen-year-old girl after a journey.

**Overloading the Stomach.—Indigestible Food.**—Burne relates the case of a boy taken sick after eating a great amount of mince-pie. Fruits with stones, as cherries and grapes, are mentioned in cases of children, Matterstock citing four cases from the literature. Oatmeal (Pepper) is said to favor the formation of intestinal concretions; so is the exclusive use of meat and fish, as by the Esquimaux in Siberia (Speck); also farinaceous food, such as potatoes (Boys de Loury).

**Emetics, Drastic Purgatives, Clysmata,** are assigned a part in the eti-

ology of perityphlitis by Bossard and others. This can only be understood to be meant in cases where a pre-existent ulcer on the verge of perforation, or an undiagnosed, localized abscess, is ruptured on account of the abdominal traumatism caused by these agents. The same holds good for such causes as dancing, coughing, efforts at defecation, vomiting, sneezing (Taverney).

**Constipation and Intestinal Catarrh.**—Bossard does not think that every little semi-solid accumulation of feces in the appendix is pathological and can of itself be a cause of perforation, since by its normal contractility even foreign bodies can be evacuated. Constipation is rarely the cause of the disease in children, but more frequently in adults (Balzer). A catarrh causing relaxation of the muscles is considered by Bossard to be a much more important cause. In thirty autopsies he found in seven cases slate-colored pigmentation of the mucosa of the appendix. Intestinal catarrh was found to have existed for seven weeks before perityphlitis in an eleven-year-old boy (Erös).

#### PATHOLOGICAL ANATOMY.

**Seat of the Primary Lesion.**—The primary lesion is much more frequently found in the appendix than in the cæcum; in fact, the latter may be said, in comparison, to play no part at all. The early use of the expression "perityphlitis," and the so-called stercoral typhlitis, which was erroneously considered an important factor in the pathogenesis, tended to draw attention away from the appendix. Post-mortem examinations very rarely showed primary changes in the cæcum, where ulcers are comparatively more common than fecal concretions, while the opposite was found to be the case in the appendix.

Changes in the mucous surface of the wall of the bowel caused by fecal concretions are the following: pressure-atrophy and coagulation-necrosis of the epithelium. These are the result of contact with a foreign body or fecal concretion, especially in the case of a mucous membrane which is the seat of a catarrhal inflammation due to other than mechanical causes. The invasion of the microbes of the intestinal tract into the unprotected subepithelial tissue causes a local phlegmonous septic inflammation. This inflammation, extending through the muscular coat into the subperitoneal tissue and peritoneum, will show the usual signs of acute septic inflammation, from hyperæmia to gangrene of the tissues involved. The destruction of the intestinal wall from within may be limited to or stop anywhere on the way from the epithelium to the peritoneal cavity, according to the laws governing such septic invasions in general. If limited to the mucous membrane and the muscular coat of the intestine affected, the cicatrix which repairs the tissue lost changes the shape and structure of the area involved. Burne noticed, in the case of a girl of twelve, who had suffered for two years from disease of the bowels, that the cæcum had become transformed into a narrow, irregular sac traversed by bands of cicatricial tissue which extended from one side of the rigid wall to the other. The appendix is

often totally or partially transformed into a connective-tissue mass, the lumen is obliterated, and eventually the distal patent portion is dilated or transformed into a so-called retention-cyst, suppuration in which may lead to further local destruction of the wall and to perforation.

A plastic peritonitis binds the surface involved to the peritoneal surfaces with which the bowel is in apposition, and the appendix or cæcum is buried in a mass of connective tissue, sometimes thick and dense, sometimes only a movable web of fine membranous adhesions. This, the lightest and most limited form of appendicitis (Fitz), which includes With's adhesive appendicular peritonitis, is exceedingly common, and is probably never recognized clinically, on account of the lack of distinct symptoms, but is an accidental discovery on the post-mortem table. The frequency is illustrated by the investigations of Toft. In three hundred autopsies he found the appendix pathologically changed, showing signs of previous disease, in over thirty per cent.; in five per cent. there was ulceration; in one per cent., perforation. Tüngel, in the autopsies in the Hamburg Allgemeine Krankenhaus for two years, observed thirty cases of total or partial obliteration, forty-three cases of catarrhal inflammation and old faecal concretions, in twelve cases adhesions, and in eleven cases tuberculous ulcers. Kraussold, as a result of three hundred autopsies, regards the frequency of abnormalities as given by Toft as too small; Ransohoff, on the other hand, after the examination of more than sixty bodies, found abnormalities of the appendix in eight only; he consequently thinks that, in this country at least, the estimate of the above-named authors is too high.

The more extensive inflammation which penetrates the intestinal wall, and thus gives symptoms recognizable at the bedside, is the only form of clinical and practical importance. As shown in the normal anatomy, the appendix and cæcum being provided with a mesentery, peritonitis must result when the wall of the bowel is penetrated. The intensity and extent of this peritonitis probably depend upon the extent of the perforation of the bowel and upon the amount of the intestinal contents which has penetrated into the abdominal cavity. In milder forms, where perforation is small or imperfect, with limited escape of the contents of the bowel, the circumscribed peritonitis of Oppolzer, or local appendicular peritonitis of With, is the result. In the graver forms, with sudden rupture of the diseased wall of the intestine and escape of the contents, acute diffuse peritonitis follows.

The localized peritonitis—perityphlitis proper—may be of the sero-fibrinous variety to a very great extent, and surround only a very small collection of pus (Aufrecht), sometimes none at all, and may terminate in recovery by absorption or resolution. Of one hundred and eighty cases of typhlitis and perityphlitis collected by Fitz, thirty-two per cent. belonged to this class. In more severe cases a localized collection of pus—the perityphlitic abscess—forms. According to Balzer, abscess-formation is much more rare in children than in adults. The seat of the perityphlitic abscess

depends upon the location of the appendix and the place of perforation. When, as is most common, it extends from behind the cæcum, upward behind the ileum and beneath the lower surface of the mesentery, pointing to the left, it may have its centre on the medial side of the cæcum, if the end of the appendix is perforated. When located behind the cæcum and pointing upward along the right side of the cæcum and ascending colon, the abscess can be located in this place (Kraussold). When the appendix reaches over the brim of the pelvis minor, according to Ransohoff a very rare occurrence, the abscess may be located in the vicinity of the rectum or uterus. In the great majority of cases the centre of the abscess is behind or around the cæcum. The walls of the cavity, therefore, are, according to the location, either coils of intestine alone, or, more commonly, partly intestines and partly the posterior or external abdominal wall. The abscess-cavity, unless distended and consequently round in shape from a large accumulation of pus, may have an infinite variety of forms according to the accident of location, a condition always found in intra-peritoneal limited collections of pus; which, of course, increases the difficulty of perfect drainage. The contained pus is commonly fetid when the perforation is large enough to admit saprogenous microbes or even faecal matter. Necrotic shreds of omentum or para-peritoneal connective tissue, or even necrotic portions of the appendix, together with gas and faecal matter, may be found. Fitz states that pus may be found on or after the third day from the beginning of the peritonitis or the perforation.

**Extension.**—A perityphlitic abscess may extend or open into any of the adjacent spaces, cavities, or organs. Usually it opens into the intestine, cæcum, small intestine, or rectum. The destruction of the wall taking place from without, the opening, whether single or multiple, is funnel-shaped or terraced. The opening in the peritoneal coat is larger than that in the muscular, while the smallest opening is in the mucous coat. It may, when the perforation takes place obliquely, be valvular, so as to hinder the escape of faeces back into the abscess (Fissier). Perforation into the bowel and evacuation of the pus or pus and blood is a common occurrence. This has been regarded, from the time of Dupuytren, as a desirable event, as the tumor disappears, fever subsides, and recovery generally follows. In many cases the abscess is so small that the presence of pus in the faeces is unnoticed (Aufrecht). Spontaneous evacuation of the pus was found by Fitz in eighteen per cent. of the cases. Evacuation into the bowel is not always beneficial, as it is sometimes followed by extension of the abscess. Perl reports the case of a child of two and a half years, in which a perityphlitic tumor suddenly disappeared, but subsequently an abscess formed, with a perforation at the umbilicus leading to the intestine. Bartholow noticed, in nineteen cases of children and adults, three perforations into the bowel and three both into the bowel and externally. After perforation into the bowel new infection takes place, from the entrance of faecal matter or a fresh invasion of microbes, followed by sepsis and death. Thus perforation

into the bowel is not so salutary as was once generally supposed. Out of six cases of children, reported by Denme, three died. Kraussold has made the observation that fecal matter, not present in the abscess-cavity at the time of operation, frequently is not seen until from four to seven days after, when defecation has taken place and renewed peristalsis has facilitated the entrance of feces into the appendix. The abscess extends to or finally through the abdominal wall in the ilco-cæcal region, or towards the umbilicus, where (Hench), in children, abscesses from perforated intestines generally come to the surface.

Opening into the bladder is rare. Bossard states that a fatal fecal cystitis, or the formation of calculus with fecal nucleus, may result. Extension of the inflammation to the ovary has been noticed by Eisenschütz in the case of a girl six years old, where the perforated appendix adhered to the right ovary, which was in a state of acute suppurative oöphoritis. Communication between the perforated appendix or the abscess-cavity and the internal iliac (Powell), or the deep circumflex iliac artery (Bryant), may be regarded as unique. Extension to branches of the portal vein is one of the features of sepsis, and a thrombo-phlebitis is ominous, as it is followed by extension of the sepsis and secondary embolic abscesses in the liver, usually with fatal result. Matterstock observed this in eleven out of one hundred and forty-six cases. Extension along the outside of the ascending colon to the liver and upward behind the latter causes a sub-diaphragmatic abscess which may perforate into the pleural cavity. Bamberger has reported two cases of the former and three of the latter condition. Tillmanns, in twenty-two cases of fecal pleural fistula, found that six, all of which were in the right pleural cavity, originated from perforated appendices. Extension through the peritoneum of the posterior abdominal wall into the retro-peritoneal tissue leads the abscess down along the psoas or iliacus muscle, or upward into the region around the kidney. In the latter case a paranephritic abscess results, in the former an abscess extending to or below Poupart's ligament, on the femur. This latter may perforate into the hip-joint (Aubry and Moore), or may perforate or extend into the perirectal tissue and point into the gluteus maximus, in the sacral or coccygeal region, as observed by Louvier in the case of an adult. Perityphlitic abscesses extending to the left side of the abdominal cavity, in the region of the spleen (Aufrecht), or the left iliac region (Bartholow), have been observed. A perityphlitic abscess opening into the peritoneal cavity will cause an acute diffuse peritonitis. This took place in six of thirty cases reported by With, and in eight of Bull's sixty-seven cases. Secondary perforation into various organs or places is more common in adults than in children. Matterstock, after the consideration of two hundred and fifty cases of adults and seventy-three of children, estimates the proportion as thirteen to five and a half.

The existence of paratyphlitis, paratyphlitic abscess, or inflammation in the post-cæcal or retro-peritoneal tissue in connection with the cæcum and

appendix, is disputed. Oppolzer believes that it often originates from the cæcum from a parametritis *in puerperium*, or as a localization during pyæmia, while it rarely originates from a local peritonitis or a psoas abscess. Of course this discussion deals only with those paratyphlitic abscesses originating in the cæcum and appendix. Most of the modern authors, because of the lack of peritoneal investment to the cæcum and appendix, deny the possibility of a primary paratyphlitic inflammation in this connection. Sands, however, asserts that most of these abscesses are extraperitoneal. This difference in opinion is probably unimportant, as a local peri-appendicular suppuration, originally of necessity intraperitoneal, when located behind the cæcum will quickly extend into the para- or post-cæcal tissue, where there is no barrier either upward to the kidney or downward to Poupart's ligament (König). Consequently the abscess is, anatomically speaking, paratyphlitic. This is the most common extension of the appendicular peritonitis. When Oppolzer attempts to give a distinct differential diagnosis between paratyphlitis and circumscribed peritonitis, it must be remembered that such a distinction is pathologically false. It would nevertheless be clinically justifiable if any important consequences as to prognosis or treatment could be deduced therefrom, but this is not the case.

Acute diffuse peritonitis, the gravest consequence of perforation of the appendix and cæcum or of the perityphlitic abscess, occurs as a result of the escape of a sufficient quantity of microbes into the peritoneal cavity, and divides with general sepsis the percentage of mortality. The exudate varies as in other forms of peritonitis; sometimes a fibrinous exudate with no fluid, at other times accompanied by a copious amount of fluid. The fact is characteristic that the exudate is usually more copious in the ileo-cæcal region, as the inflammation begins at this point. Even when large openings into the appendix are present, fecal matter or air rarely escapes into the peritoneal cavity, as is the case in perforative peritonitis from other parts of the intestine. This is probably due to the fact that the appendix seldom contains much air or feces, to escape through the opening. Perforation of the appendix is often followed by diffuse peritonitis. Thus, Volz reports this in thirty-one out of thirty-nine cases, Cless in seven out of eight cases. With reports thirty cases of appendicular peritonitis, of which sixteen were diffuse; twelve of these resulted fatally; in two, diffuse peritonitis was caused by perforation of the abscess into the peritoneal cavity.

#### SYMPTOMS.

It is difficult—almost impossible—to give a well-defined symptomatological description of perityphlitis, because there is nothing typical in its course. The inflammation may cease at any point, from its origin in the mucous membrane to its diffusion to the whole peritoneal cavity, or its secondary extension to adjacent or remote parts of the body. At the same time the unity at the starting-point is rather constant, and the pathology, always in view, furnishes a guide through the great variation in symptoms

and course. Albers divides the disease into prodromata followed by two stages. Cless classifies the symptoms into premonitory symptoms, symptoms of the beginning of the disease, and symptoms of the further course. Bossard distinguishes between the symptoms of three forms of the disease,—a light, a median, and a severe form. With, keeping the pathology more in view, makes the classification of symptoms as follows: first, the symptoms of an adhesive appendicular peritonitis, corresponding to the premonitory symptoms; second, a local appendicular peritonitis with or without abscess, corresponding to the light and median forms of Bossard; and, third, a universal appendicular peritonitis, corresponding to the fatal cases of Bossard's severe form. With's division of the symptoms is manifestly the most exact and scientific.

Prodromal symptoms, according to Matterstock, are more common in children than in adults. In thirty per cent. of his cases of children he found that the premonitory symptoms preceded the disease by days, weeks, or even years. These consisted of mild or severe attacks of colicky pains in the cæcal region, a little tenderness localized here, nausea, and occasional vomiting, constipation alternating with diarrhœa, followed by flatulence and painful tenesmus. Such attacks may have kept the patient in bed for a day or two, or may have passed almost unnoticed. Adults sometimes state that these slight disturbances were exactly similar to the initial symptoms of the final, severe, or fatal attack of the disease (With). It is evident that in the case of smaller children it is almost impossible to recognize these premonitory symptoms in their true light.

The symptoms of local appendicular peritonitis or perityphlitis are: Sudden violent pain in the region of the cæcum, or, more rarely, in the epigastric region, the patient having been in apparent good health; the patient cannot walk nor stand straight, but bends forward and to the right, and lies down with the right leg slightly flexed on the hip. The pain may be general, all over the abdomen, and not be localized in the cæcal region for several hours or days. Coughing or deep inspiration increases the pain, as does the effort to extend the right leg. The pain makes the patient keep quiet in bed, or may by its severity, notwithstanding the tenderness and pain, cause him to move restlessly around in bed, in the effort to find a position in which there will be relief from the pain. With says that this occurs usually in the cases in which the inflammation remains localized. A copious meal may directly precede the pain. There is vomiting, first of the food-contents of the stomach, later of bile: sometimes there will be only a single emetic effort, but not uncommonly there will be several, accompanied by borborygmi and flatulence. Clysmata or injections may induce the vomiting, which is, as a rule, speedily subdued by opiates. Symptoms of ileus, and especially faecal vomiting, are rare. The appetite is lost entirely, but the patient is usually thirsty. An initial chill is more rarely met with in children than in adults. Fever is generally an early symptom, sometimes preceding the pain, the temperature ranging from 101° to 103° F., with a remis-

sion in the morning. The pulse is usually accelerated, ranging from 90 up to 130. Sometimes a high pulse is observed with low temperature. The general expression is that of a severe illness. Light icteric discoloration of the skin and conjunctiva is sometimes seen. In smaller children convulsions, and delirium in the milder forms, are common. The urine may be scanty and saturated, and urination painful, even when no peritonitis has as yet reached the region of the bladder. The retention of urine, and pain in the region of the bladder and external genitals, may divert attention from the actual seat of the disease. Constipation is less common in children than in adults. Diarrhoea is frequently present, either alone, or alternating with constipation.

The abdomen is either tense and flat or, later on, slightly tympanitic. There is general tenderness on pressure, most pronounced in the ileo-cæcal region; or the tenderness may be localized in the latter place. The increased tenseness in the ileo-cæcal region is often accompanied by prominences from local accumulations of gas in the intestines, or later from peritoneal exudates. A tumor in the cæcal region may soon appear, smooth or nodulated, elastic or firm, immovable, and increasing to the size of a fist. Contraction of the abdominal muscles frequently prevents palpation, so that the location of the tumor, if deep-seated, cannot be determined except in narcosis. Later on, when the tenderness has subsided, the tumor may be easily made out. Tense or inflated anse of intestine may be felt in or near the ileo-cæcal region (With). Pressure on or inflammatory irritation of the crural nerve or the crural plexus may cause radiating pains, formication, or numbness in the leg and in the region of the genital organs. Pressure on the iliac vein may produce œdema of the leg. Percussion is usually dull tympanitic, from exudates or tense or inflated anse of intestine, seldom completely dull, in the cæcal region. The rest of the abdomen is tympanitic. Respiration is often accelerated, embarrassed, or superficial, on account of pain or of pressure on the diaphragm.

**Course.**—In the milder cases the vomiting and paroxysmal pain cease after a few days, the temperature gradually goes down, the tension in the right iliac fossa subsides so that it ceases in two or three weeks, and the exudate is absorbed. In more severe cases the symptoms persist longer, but gradually disappear. Alvine evacuations become regular, after free passage of wind and offensive fæces; the appetite returns; meteorism disappears; the tumor subsides, though for months a gradually decreasing deep-seated induration, the pericæcal cicatrix, may be felt. Slight attacks of pain or uneasiness in the cæcal region, called forth by overeating or bodily exertion, may remain for a long time, and act as a warning of relapse. A sudden subsidence of the alarming symptoms is seen when spontaneous evacuation of the abscess into the intestine takes place: the appearance of the patient is entirely changed in a few hours; the vomiting stops; the fever disappears; sleep, accompanied by perspiration, comes on. Copious passages from the bowels, mixed with pus, sometimes streaked with



blood, announce the breaking of the abscess. The tumor disappears at the same time, or subsides so as to leave only a deep-seated resistance, with little or no tenderness on pressure.

In more severe cases of localized perityphlitis the symptoms persist: there is no evacuation of the abscess, no sudden subsidence of the symptoms; but, after a more or less pronounced remission, due to the limitation of the inflammation, a further exacerbation sets in, due to pyæmic localizations in remote organs. Pyothorax, pericarditis with dyspnoea, thoracic pain, higher temperature and increased prostration, extension of the septic inflammation to the retro-peritoneal tissue, invasion of the paranephritic region and pararectal tissue, perforation of the diaphragm, causing a pyopneumothorax, usually if not exclusively on the right side, perforation of the bladder, with the symptoms of cystitis,—all these complications protract the disease and make the patient remain in a prolonged state of danger until, according to the gravity of the lesion, death from sepsis or exhaustion, or a slow and often imperfect recovery, ensues.

A sudden onset of the grave symptoms,—intense diffuse abdominal pain, collapse, frequent pulse (from 130 to 160), low or exceedingly high temperature (from 105° to 106° F.),—brought on by a passage from the bowels, a fit of coughing or laughing, or without any such cause, while the patient is in apparently good condition, means perforation of the abscess into the general peritoneal cavity, which, unless immediate operative interference is resorted to, will terminate fatally in a short time.

Finally, the perityphlitic abscess may be well encapsulated; no acute sepsis or perforative peritonitis sets in, but the abscess works its way slowly to the surface through the abdominal wall,—often at the umbilicus in children, or down the femur,—or points in the lumbar region. Fever usually slight, remittent, with evening exacerbations, loss of appetite, persistent tenderness and tumor, gradual loss of strength and weight, are indicative of this condition. Operative interference should at this time avert the ever-present danger of sudden fatal extension of the disease.

The severest group of cases, the diffuse acute perforative peritonitis from the appendix or cæcum, commences with sudden pain, extending rapidly all over the abdomen. The pain is often extreme, excruciating, so that the patient cries out loudly, and the slightest touch to the abdomen is intolerable. He hardly dares to draw his breath, twists together or draws up the legs, and at last nearly faints or has an attack of convulsions. There is immediate collapse, with cold clammy perspiration; the pulse ranges from 90 to 140, strong at first, later small and compressible; temperature from 100° to 105° F. The vomiting, at first of food, soon becomes bilious, but rarely stercoraceous. Opiates have little effect on the pain and vomiting. The pain occasionally intermits, but quickly returns, and requires a larger dose of the narcotic. The vomiting, often accompanied by persistent hicough, usually increases in frequency, and may last until the end, or, rarely, may abate. Foul eructations occur, even in cases where the

vomiting is not fecal. Constipation or diarrhoea may be present; the latter often becomes very copious towards the end (Pott). Tympanites, which is not present at first, usually develops rapidly, until the abdomen is distended like a drum, with tense and shining skin. Coils of distended intestine may show through the abdominal wall. The tumor cannot be felt, even before the tympanites is developed, as no localization of inflammation has yet taken place, or as a presenting abscess has emptied into the abdominal cavity. There may be no fulness in the ileo-cæcal region (Pepper). The urine is scanty, saturated, and shows traces of albumen. The urinary tenesmus and frequent urination or retention are due to pericyclic inflammation. Delirium and convulsions are not uncommon in the later stages of the disease. Death takes place from collapse, rarely in from six to twelve hours; usually, however, the disease lasts from one to three days, seldom longer. Recovery is very infrequent.

When perforative peritonitis occurs in infants during the period of lactation, they become restless, will not take the breast, vomit repeatedly, have profuse diarrhoea, meteorism, and tenderness of the abdomen, with frequent respiration, followed by collapse and death. If the disease lasts more than a few days a rapid and characteristic loss of weight, up to one hundred and eighty grammes daily, occurs (Silbermann).

**Review of Single Symptoms.**—*Pain.*—Sudden intense pain is the most constant symptom of perforation of the appendix and cæcum, and is present in eighty-four per cent. of all cases (Fitz). The pain is less acute and severe in the perityphlitis that remains localized, or where the perforation of the appendix is imperfect. In children it is almost always present, and, if localized in the ileo-cæcal region, important. Fitz gives the following table of localization of pain in appendicitis and perityphlitis:

LOCALITY.	APPENDICITIS.	PERITYPHLITIS.
Right iliac fossa . . . . .	48 per cent.	60 per cent.
Abdomen . . . . .	36 "	34 "
Hypogastrium . . . . .	5 "	0 "
Umbilical region . . . . .	4 "	2 "
Epigastrium . . . . .	2 "	4 "
Stomach . . . . .	1 "	0 "
Hepatic region . . . . .	1 "	0 "
Left iliac fossa . . . . .	1 "	0 "
Right hip and groin . . . . .	0.5 "	0 "

Smaller children show uneasiness and rarely cry out loudly: usually they cry intermittently. As a rule, in children the pain is often an early symptom, even in attacks preceding the actual inception of the disease (Matterstock). Pain at first slight, but gradually increasing for a few days before the patient goes to bed (Homans's case), may signify local perityphlitis. Pain more acute at first, increasing, and uncontrollable by opiates, may mean spreading general peritonitis. Pain diffuse in the beginning, later localized to the cæcal region, indicates local peritonitis. Dis-

appearance of pain in the diffuse peritonitis, when the other grave symptoms persist and collapse sets in, is an indication of early fatal termination. Sudden intense pain as a symptom of the beginning of a more extensive peritonitis occurred, according to Fitz, in appendicitis and perityphlitis respectively, as follows:

TIME.	APPENDICITIS.	PERITYPHLITIS.
First day . . . . .	67 per cent.	75 per cent.
Second day . . . . .	8 " "	16 " "
Third day . . . . .	20 " "	3 " "
Fourth day . . . . .	3 " "	6 " "
Fifth day . . . . .	2 " "	0 " "

*Vomiting* is an almost constant symptom in children. It was present in all of Pepper's thirteen cases, and was absent in only two of Matterstock's seventy-two cases. It is not so constantly present in adults, as it was observed by Fitz in only fifteen cases of appendicitis and in forty-four out of two hundred and nine cases of typhlitis and perityphlitis. This difference may be accounted for by the liability of children to vomit on slight provocation, as compared with adults. Vomiting was stercoraceous in none of Pepper's cases and in one only of those tabulated by Matterstock (Volz's case). Initial vomiting is more constant and copious in the cases of localized pericæcal peritonitis with final recovery than in the severer cases terminating in rapidly-spreading general peritonitis (Pepper).

*Constipation or Diarrhœa.*—While in adults the bowels are usually constipated, diarrhœa is often observed in children. Matterstock found diarrhœa in 33.3 per cent., constipation in 46.6 per cent., alternating constipation and diarrhœa in 15.5 per cent., and the normal alvine evacuations in 4.5 per cent. only. Pott observed that children were more liable to diarrhœa than to constipation, and that in the last stage of fatal cases there were violent liquid evacuations. Silbermann noticed profuse diarrhœa in children at the stage of lactation in diffuse peritonitis. The evacuations towards the end of fatal cases are often of a peculiarly fetid odor.

*Tumor.*—It is important to distinguish between simple tension of the abdominal muscles over the iliac fossa and a palpable tumor. According to Gerhardt, it is less common to find a tumor in children, because the inflammation is more liable to spread to the greater portion of the peritoneum. In nineteen cases recorded by Pepper, of children under fifteen years of age, a distinct tumor could be felt in three cases only. It is possible, however, that the use of an anæsthetic would enable us to distinguish a tumor more often. Fitz has attempted to tabulate the day of the disease when a distinct tumor can be felt, in both children and adults. Out of ninety-two cases, the tumor was felt on the first day in five, on the second in nine, on the third in twelve, on the fourth in ten, on the fifth in seven, on the sixth in eleven, on the seventh in eight, on the eighth in eight, on the ninth in eleven, and on the tenth in eleven cases.

*Percussion.*—Dulness of percussion may be found when the exudate is superficial; it may be absent when the exudate is covered by distended loops of intestine, or when intestinal gases have invaded the area of inflammation. The date of its appearance, as stated by Fitz from thirty-seven cases, was on the first day in two, on the second in two, on the third in eight, on the fourth in nine, on the fifth in three, on the sixth in two, on the seventh in two, on the eighth in five, on the ninth in one, and on the tenth in three cases. Accumulation of gases in the free peritoneal cavity, causing disappearance of dulness of the liver and spleen, is rarely seen, and is often prevented by adhesive peritonitis in the upper half of the peritoneal cavity. Again, dulness of the liver may be absent on account of intra-intestinal accumulations of gases,—that is, tympanites. Larger accumulations of liquid exudate in general peritonitis may exist without any perceptible dulness of percussion, the symptom being masked by overlying tympanitic loops of intestine.

*Temperature* usually ranges between 100° and 102° F.; With has once observed a temperature of 106°. The fever is atypical; in localized inflammation with final absorption it is often irregularly remittent. Armand Paulus observed a temperature of 104° F. in the case of a child who recovered; usually it does not exceed 102°. A gradual fall in temperature is the rule; a sudden fall is noticed only in cases where a sudden evacuation of exudates by operation or perforation into the intestine has taken place. Sands saw the temperature fall from 101.6° to 98.5° F. within an hour after laparotomy and remain below 100° or 99° during convalescence. Sudden and repeated rise of temperature during the course of the disease signifies the invasion of either a new territory of the peritoneum or of distant organs by septic material, embolism, or abscesses of the liver. In the latter case rigors may be seen repeatedly. Initial rigors are not very common in children. Sudden fall in temperature, with frequent, weak pulse and symptoms of collapse, may mean perforation and diffuse peritoneal sepsis. Even in lighter cases in children the temperature may rise comparatively higher than in adults, on account of the greater variability of the bodily temperature in early life (Matterstock).

#### DIAGNOSIS.

Previous attacks of pain or inflammation in the cæcal region call attention to the appendix and cæcum. Relapse was found in eight per cent. of children's cases by Matterstock, and in five out of thirty cases of adults. With found that symptoms of his "adhesive peritonitis" had preceded the disease for from two months to ten years. It is natural that the lighter symptoms in children, the slight colicky pains and vomiting lasting only a day or two, should be overlooked, or regarded as unimportant. Thus, only the more severe or repeated localized inflammations in the cæcal region in children can be of any aid in diagnosis.

**Stercoreal Typhlitis**, coprostasis in the cæcum or ascending colon, is

said to be much more common than perityphlitis (Fitz). This statement applies to adults, but in children constipation is more rare: Demme in thirty-six cases of typhlitis and perityphlitis found coprostasis in only nine. In stercoreal typhlitis there is a history of constipation for some time preceding the attack, and this may lead to vomiting, convulsions, pain, and even fever (Matterstock) for a day or two. The tumor, however, has a doughy feel, is movable, and less painful; fecal masses may be felt in the descending colon and in the sigmoid flexure; as a rule there is no fever, as there is no inflammation; and a laxative causes the speedy disappearance of the tumor, as well as of all the symptoms.

**Invagination—Strangulation.**—The symptoms may be similar (Gautier). In invagination bloody evacuations in children under one year of age are common. The obstinate constipation, location of the tumor in the left side of the abdomen, mobility of tumor, absence of fever, all aid in the differential diagnosis. The pain is not intense nor localized in the iliac fossa. In internal strangulation the absence of tumor and lack of tenderness of the abdomen are of importance. Fæcal vomiting is common in the later stages of obstruction: it is never seen in perityphlitis, and rarely in general peritonitis.

**Perinephritic Abscess** will usually be accompanied or preceded by some abnormality in the urine. Passage of a renal calculus (renal colic) is characterized by absence of tumor, demonstrable in narcosis, and is not accompanied by fever, but there are sometimes blood or concretions in the urine.

**Psoas Abscess**, which might be mistaken for chronic perityphlitis or iliac abscess, is less painful, more diffusely fluctuating, with little or no rise of temperature. It has no acute onset. There are no symptoms pointing to the intestinal tract, and there is no peritonitis. A careful examination of the spinal column or iliac bones, with the symptoms characteristic of diseases in this locality, will make the differential diagnosis comparatively easy.

**Hip-Joint Disease.**—Gibney reports four cases of perityphlitis in children which were brought into the hospital and diagnosed as hip-disease,—one of which was treated by extension with weight and pulley for nearly two weeks. As the flexion of the thigh in the hip-joint and pain on movement are due to inflammation in the iliac fossa, the use of an anaesthetic will clear up the diagnosis, by showing that movement in the hip-joint is unimpaired. In acetabular tuberculosis with early perforation into the pelvis, and in intrapelvic abscess, the tumor is near Poupart's ligament and lower down than in perityphlitic abscess, which is located near the anterior superior spine of the ilium.

**Rectal Insufflation of Hydrogen Gas.**—A valuable aid in diagnosing perforation of the appendix or cæcum, and its communication with either a localized abscess-cavity or the general peritoneal cavity, may be found in the rectal inflation by hydrogen gas, as advised by Senn. He employed the test in a case of perityphlitis in a middle-aged man. No operation was found necessary, and the patient recovered. In case the gas should enter the peritoneal cavity, immediate laparotomy would be indicated.

## PROGNOSIS.

The gravity of perityphlitis depends entirely upon the extent of the septic inflammatory process. If the inflammation remains localized to a limited area of the peritoneal cavity, and does not extend through the vascular system to distant organs, the prognosis is favorable. Acute extensive perforation of the appendix or cæcum, with copious invasion of the peritoneal cavity or retro-peritoneal tissues, and rapidly-spreading septic inflammation, is almost always fatal. It is necessary to bear in mind that the disease is always dangerous, as an apparently slight case may at any moment, and especially under inappropriate treatment, become an extremely grave one. It is difficult and almost impossible, therefore, to give a reasonably certain prognosis in any given case. The statement of Bauer, Bamberger, and others that simple perityphlitis, especially if of traumatic origin, has a good prognosis, and that the prognosis becomes grave in all cases of perforation, is of little assistance to the physician at the bedside, as an exact diagnosis of perforation or its extent is impossible.

The mortality, as derived from the statistics, varies according to the selection of the cases or their arbitrary division into certain clinical groups. Volz had thirty-nine fatal cases out of forty-nine; Bamberger, only eighteen out of seventy-three; Bull, thirty-three out of sixty-seven; Matterstock out of nine hundred and seventy-seven cases had two hundred and ninety-four deaths, or thirty per cent., and six hundred and eighty-three recoveries, or seventy per cent.; With had thirty cases, with twelve deaths. In adults and children, therefore, the mortality is more than thirty per cent. The prognosis in children is, according to Matterstock, even more grave. Of seventy cases forty-nine died and twenty-one recovered, a mortality of seventy per cent. When Demme, on the other hand, records thirty-six cases of typhlitis and perityphlitis with twenty-seven recoveries and nine deaths, it must be considered that an unknown number of the lighter cases may have been simple coprostitis in the cæcum. In children sex makes no difference as to the mortality. Matterstock remarks that seven out of ten cases are fatal, whether the patients are boys or girls. Young children have less power to resist the disease than older ones. Out of twelve patients below the age of six, eleven died. Between six and ten years the prognosis was more favorable,—twenty-four cases with fifteen deaths. Between the ages of ten and fifteen the mortality seemed to increase, as out of thirty-four cases twenty-three were fatal.

When a diffuse peritonitis develops immediately after the perforation or first onset of the severe symptoms, the prognosis is almost uniformly fatal. With reports fourteen cases of universal appendicular peritonitis, with two recoveries and twelve deaths. If the perityphlitis becomes localized but suppuration takes place,—that is, the abscess forms,—the prognosis depends upon what course the abscess takes. If it opens into the general peritoneal cavity, a fatal diffuse peritonitis results (With, two cases). Evacuation of

the abscess into the cæcum is more favorable: Bull gives ten cases with nine recoveries. Demme reports less favorably, however, in children: out of his six cases three died. Evacuation into the rectum justifies a good prognosis (Bull). Perforation into the pleural cavity, causing empyema, is usually fatal, and, even if a fecal fistula forms (Tillmanns), death results later from chronic sepsis or exhaustion. Perforation into the bladder is fatal in one-half the cases (Bull). Evacuation through the abdominal wall, which was considered by Dupuytren to give a grave prognosis, is now looked upon in a different light, when a direct outlet for the pus is secured at an early stage of the disease. It may be justly considered a triumph for surgical interference when out of one hundred operations recorded by Noyes the mortality was only fifteen. The result is different when the abscess is left to burrow its way out through the abdominal walls, destroying tissue in its course. Of twenty-eight cases collected by Bull eleven were fatal. Pyæmia caused death in six out of sixty-seven cases (Bull).

The length of time between the onset of the severer symptoms and death has been noted by Fitz, who, in a series of one hundred and seventy-six cases, found that thirty-four per cent. died within the first five days, fifty-six per cent. within the first week, thirty-one per cent. in the second, and only four per cent. in the third. The prognosis is uniformly favorable in the adhesive or plastic appendicular peritonitis; but it must be remembered that after months or years a relapse may occur in the shape of an acute fatal form of the disease. In the local appendicular peritonitis the prognosis is favorable when the acute symptoms subside in a few days, when pain and tenderness become limited to the iliac region, and when the tumor remains small and gradually diminishes as the exudate, whether fibrinous or purulent, is removed by absorption. We must bear in mind, however, that even the smallest induration around the appendix or cæcum is a source of constant danger, and that the greatest care in diet and regimen is necessary to avoid the possibility of a rekindling of the dormant inflammation, the renewal and extension of which might prove fatal at any time.

#### TREATMENT.

**Prophylaxis.**—As the disease usually commences unexpectedly in previously healthy persons, it is impossible to do much to prevent an attack of perityphlitis. Regulation of the diet of children, so as to prevent the accumulation of indigestible substances in the appendix or cæcum, should be taken into consideration. Digestive disturbances, especially when accompanied by colicky pains in the iliac region, may give warning of a coming attack. The utmost care should be taken in regulating the diet and the whole regimen of children thus affected. Over-eating, over-exertion, exposure of any kind, should be avoided. A careful rectal and abdominal examination, in narcosis if necessary, should determine whether any induration has formed around the appendix, that the care and precautions so essentially necessary may be resorted to.

The treatment of a developed perityphlitic inflammation is as yet in some essential points a matter of controversy. Morton insists on the division of the disease into a pre-purulent and a post-purulent stage. In the first, medical treatment is resorted to; in the second, operative measures are employed. In the pre-purulent stage the main controversial question is whether the bowel should be evacuated when the constipation exists, or whether absolute rest of the intestines should be aimed at. If a certain diagnosis can be made between stercoreal typhlitis and perityphlitis, the question is easily solved, and cathartics or clysmata will be as beneficial in the former as opium or morphine in the latter case.

Opium in large doses is recommended by Stokes and Graves, who give children one-fourth of a grain every hour as long as there is general tenderness over the abdomen. Volz strongly insists upon the opium treatment, and warns against cathartics and enemata. It is generally admitted that the great mortality which existed at the time of Volz has been considerably lessened in later years by the opium or morphine treatment. Matterstock advises absolute rest of the intestinal canal in all cases where even a slight tenderness and swelling exist in the ileo-cæcal region, and says that, although the disease may appear to be insignificant, it must be combated most energetically, by absolute rest, liquid diet, and opium in large doses. He cannot warn too earnestly against any attempt to relieve constipation by cathartics or clysmata. Hydrate of chloral is recommended by Silbermann, for young children, in preference to morphine. He gives a teaspoonful every two or three hours of a one- to three-per-cent. solution.

**Purgatives.**—Among modern authors, Morton insists that salines and enemata should be employed in the early stage of the disease, to keep the inflamed intestine free from accumulations of gas and feces. Pepper recommends liquid citrate of magnesia, repeated at short intervals, or repeated doses of calomel until the bowels are opened. With, on the other hand, while admitting the usefulness of laxatives in stercoreal typhlitis and the early stage of typhlitis, warns against their use in the early stage of appendicular peritonitis or perityphlitis, basing his argument upon the fact that the twelve fatal cases of his series of thirty had all been treated at the beginning of the disease with castor oil or enemata, and all died from diffuse peritonitis. All authors agree that purgatives or enemata must not be employed in the developed, acute stage of a local or general appendicular peritonitis or perityphlitis. When the patient progresses favorably, resolution is taking place, and pain and tenderness have disappeared, mild laxatives, alone or combined with opiates, are recommended. Pepper gives the following prescription :

R Pulv. opii, gr. ii to iii ;  
Ext. colocynth., gr. xii to xviii.  
Misc.

Ft. mass. Div. in pil. xxiv.

One pill every three to four hours until action of bowels.



**Enemata.**—Monti advocates irrigation of the intestines with water or drastic remedies at the beginning of the disease. Balzer recommends clysmata when constipation exists. Pepper uses a tepid non-irritating enema. Matterstock will use enemata only in the later stages of the favorable cases when, as is rarely the case, spontaneous passage of the bowels has not taken place after the discontinuance of the opium.

**Local Depletion or Counter-Irritants.**—In the acute stage an ice-bag or hot fomentations are applied over the iliac fossa. Matterstock recommends a small ice-bag suspended from a frame, so as to avoid pressure on the abdomen. With believes that application of cold,—ice-bag or wet towels,—although it lessens pain, protracts or prevents the formation of adhesions around the place of perforation. He therefore prefers hot applications, which seem rather to favor a plastic peritonitis. Frequent applications of mustard plasters or turpentine stupes may allay pain. Bull and Balzer use leeches. Blisters are recommended by Balzer. If the tumor disappears slowly, applications of blisters or tincture of iodine are useful. Vomiting is relieved by ice or carbonated drinks or by subcutaneous injections of morphine.

The diet in the acute stage must be liquid, given in small quantities at short intervals. Later on, when the pain and acute symptoms have subsided, solid food may gradually and cautiously be given.

The convalescence must be watched with the greatest care, as relapse is always to be looked for, and as intestinal disturbances on slight occasions are common reminders that the inflammation is only dormant and may be aroused at any time. On this account, the diet must be watched carefully for a long time, the bowels kept regular, and no fecal accumulations allowed to take place. Violent bodily exercise, jumping the rope, gymnastics, children's games involving over-exertion, exposure to cold, cold baths, swimming, etc., must all be avoided.

The perityphlitic abscess, or, as it is termed by Morton, the post-purulent stage of perityphlitis, is rapidly passing from the domain of internal medicine into that of modern surgery. There can be no doubt that spontaneous resolution of an abscess may take place; that in a large number, probably in the majority, of the thirty-two per cent. of Fitz's cases in which resolution was the outcome of perforating appendicitis, pus was present. Consequently, perityphlitic abscess may as yet be claimed to some extent by internal medicine for conservative treatment; but modern surgery seems to have proved that it has it in its power to diminish the mortality of the disease. It is therefore timely, in closing the discussion of perityphlitis, to take up the question of its surgical treatment by operation.

#### OPERATION.

**Introductory Remarks.**—Abscesses of the right iliac fossa had been incised before the days of Dupuytren, when fluctuation made the presence of pus certain, on the same indications as abscesses in general. The open-

ing of a perityphlitic abscess after the pus has penetrated the abdominal wall and become subcutaneous should not be termed an operation for perityphlitis. The increasing knowledge of the pathological details of the course of the disease, the dangers apt to arise during its course at a period long before fluctuation could be detected, and the cases where, according to the anatomical condition, fluctuation would not be present, gave an impulse in the direction of early operation when either the localized peri-cæcal or peri-appendicular collection of pus had been diagnosed by the presence of a tumor or swelling or local tenderness and the other symptoms, or where general peritonitis from perforation or other causes had set in. We thus distinguish between the operation on localized suppurative peritonitis—that is, perityphlitic abscess—and the operation for diffuse perforative peritonitis.

**Operation for Perityphlitic Abscess.**—The first object of operative interference in such cases is to evacuate the pus by incision, or, in addition to evacuation, to attack the primary cause or seat of the disease, the perforated appendix or cæcum, in order to close the perforation in the intestine. The first of these indications was naturally the first to be acted upon. The first operation of this kind was made by Prof. Willard Parker in 1843. As his second case was not published until 1867, it may be said that Dr. Hancoek, of London, who operated in 1848, and advocated the operation in the same year in the *London Medical Gazette*, was the originator of the operation. Hancoek's proposal was not adopted, however, and the old conservative method was persisted in until 1867, when Willard Parker reported four cases, with three recoveries, treated by incision above and parallel with Poupart's ligament to the transversalis fascia, which was then divided upon a director and the pus evacuated. Prior to Parker's article, Gurdon Buek advocated operating before fluctuation, by making an extra-peritoneal outlet for the matter below the outer half of Poupart's ligament, so as to get behind the iliac fascia and thus avoid the peritoneum,—the operation being almost subcutaneous. Dr. Parker's article and advocacy had such an effect upon early incision that Dr. Noyes in 1882 was able to report one hundred and nineteen operations, with a mortality of only about sixteen per cent. How little the operation had been resorted to outside of the United States may be seen from the statement of Matterstock in 1880, who says, "How much aid in the treatment of the earlier stages of perityphlitis operative interference can give cannot yet be told, as the cases on record are so few."

*Aspiration as a Curative Measure.*—Noyes mentions seven cases, all of which recovered; but in five a subsequent incision was required later. One was aspirated through the rectum. As a curative measure, aspiration is not to be recommended.

*Locating the Abscess by Means of the Aspirator-Needle.*—The pain, tenderness of the abdominal muscles, and tympanites may make it impossible to locate even a tumor without narcosis, for which in children chloroform should be used. The tumor may be œdema or infiltration for the most part,

including a small amount of pus, in a small focus or a long or flat cavity. Thus, to locate the pus-cavity, a fine aspirator-needle has been used. Opinions differ very widely as to the advisability of this procedure. As a valuable aid to diagnosis, Noyes leaves the needle in, and cuts down upon it as a guide. This is also recommended by Gurdon Buck, W. T. Bull, and Weir. Kraussold advises the eventual use of cautious aspiration. Sands gives an emphatic warning against the use of the exploring-needle at a very early period of the disease, as it might pass through a healthy peritoneal cavity, or through the intestine into the pus-cavity, and, when withdrawn, cause infective diffuse peritonitis. Even at a later stage of the disease this might take place if the puncture were made in front of the tumor. The time-honored procedure of leaving in the needle when pus has been detected, and cutting down upon it as a guide, must be carried out cautiously. When the free peritoneal cavity is encountered over the tumor, the needle should be withdrawn and further incision postponed until adhesions have formed. The wound should be packed with iodoform gauze, and the tear in the peritoneum, from the movements of the needle, sutured. Lange found in an operation, after the usual incision into the free peritoneal cavity over the tumor, that it was covered with omentum. He closed the peritoneal opening, and opened the abscess more laterally where the peritoneum of the abdominal wall was adherent to the tumor. The patient made a good recovery. Smith states that the use of the exploring-needle is liable to serious objections and dangers, and that it is not a useful addition to our means of diagnosis. Ransohoff says, "Place not your faith in exploratory punctures." Morton declares that "the aspirator-needle must never be used, for if it does not find pus we cannot be sure that none is present, whilst its own dangers are not inconsiderable. In these cases it is a poor and especially unsafe diagnostic measure."

*Place of Incision.*—1. Above and parallel to Poupart's ligament, usually its outer half: Hancock, Parker, the great majority of operations (Noyes). From four to six inches long.

2. Transverse incision above and along the crest of the ilium: Bontecou, Hadden (curvilinear).

3. At the summit of the tumor: Parker, Gibney, Vander Veer (nearer the median line than 1 and 2).

4. Vertical incision over the cæcum is the best, because it affords the easiest access to the presumably diseased parts (Sands, 1888). It is preferable to median laparotomy. The surgeon must know at the outset whether he will perform laparotomy or incision of the abscess.

*Lateral Laparotomy.*—In speaking of laparotomy for perityphlitis, perityphlitic abscess, or local peri-cæcal purulent peritonitis, it is important to recognize the fact that the general peritoneal cavity is healthy, guarded as yet by limiting adhesions. It is understood also that by the term laparotomy is meant the operation by which the abscess is reached through this healthy peritoneal cavity. It might be termed intra-peritoneal operation

for perityphlitic abscess. As a lateral longitudinal incision over the cæcum is the only one that gives ready access to the appendix and its surroundings, and that permits closing of perforations in the appendix and cæcum, or removal of the appendix, it is important to know if this incision can be made, whether a healthy peritoneal cavity is opened or not, and pus evacuated and drained without infection of this healthy peritoneum and consequent fatal peritoneal sepsis. Homans records the first successful case of this kind. A boy eleven years of age had pain in the iliac region for five days; was in bed three days; dulness, tenderness in right iliac fossa; no swelling; pulse 120, temperature 102.4° F. Incision was made half an inch anterior to the spine of the ilium. After opening through the abdominal wall, loops of healthy intestine showed in the wound. On passing the finger below and behind the presenting loops, deeper loops were found agglutinated with recent exudate of adhesive inflammation. Separating these with the fingers, a cavity was opened, from which two ounces of fetid pus welled up. As far as possible the abscess was emptied, and the pus prevented from running in among the coils of intestine. A double rubber drain was introduced into the pus-cavity, and the abdominal incision closed around the projecting end of the tube. There was a free discharge from the tubes for two weeks; temperature varied from 99° to 102.9° F. The patient was out of bed in three weeks after the operation. No exploratory puncture was made before the operation.

It would be dangerous to arrive at general conclusions from a single case. Many unpublished fatal cases of this kind undoubtedly exist, as in my own experience, for instance, in a boy six years old. It is always dangerous to drain an abscess through a healthy peritoneal cavity, as it is beyond the power of surgery to prevent infection along the outside of the drainage-tube. When practicable, and when it has been seen that the lateral incision leads into the healthy peritoneal cavity, it will be safer to close the opening without penetrating into the abscess, and try to reach it at another point where adhesions to the wall have already formed, as has already been stated in the consideration of Lange's case.

*Median Laparotomy.*—Laparotomy in the linea alba has been resorted to with success by Hoffman, in the case of an adult woman. At the beginning of the second week of the disease the pulse was 128, with high temperature and abdominal tenderness. A median incision was made and the cæcum found adherent to its surroundings. After separating the adhesions, two ounces of fetid pus were found around the discolored cæcum; the appendix was almost buried in pelvic tissue, and was afterwards removed. The pelvis was washed out, no antiseptics being used, however, and a rubber drain inserted through the abdominal wound, which was closed around the tube. The stiches and drain were removed on the tenth day; on the twenty-fourth day the patient was out of bed. She had pain for two years, which ceased upon the removal of the appendix.

As stated above, a lateral incision is always preferred, on account of the

easy access to the diseased appendix and its surroundings, and affords a more direct route for drainage than the median laparotomy, which, however, is preferable to lateral incision in cases of diffuse peritonitis.

*Operation for Diffuse General Peritonitis.*—Laparotomy must be resorted to, and at as early a period as possible, when the peritonitis has no tendency to limitation, but steadily, quickly or slowly, spreads until finally the entire peritoneal cavity is involved. On this question there is no discussion among authors. If the peritonitis can be intercepted on its progressive march from the iliac fossa, while as yet only a portion of the territory is inflamed, so much the better for the patient. We have the choice between lateral and median incision, the former giving better access to the appendix and cæcum for operations on them, the latter affording freer access to the general peritoneal cavity for disinfection and removal of the fluid exudate.

*Lateral Laparotomy.*—The first successful case on record of lateral laparotomy in a commencing, spreading, and unlimited peritonitis was reported by Sands in 1888. The patient, a boy, forty-eight hours after the onset of the disease had pulse 130, temperature 101.6° F., respiration 32. An incision was made to the parietal peritoneum, which was thickened and opaque. The introduction of the hypodermic needle revealed pus. A free incision into the peritoneal cavity was made, and a little air and an ounce of fetid pus escaped. Both the parietal and the visceral peritoneum on the cæcum and the small intestine were covered with pus and recent exudate. There were no adhesions limiting the spread of the peritonitis, and some coils of small intestine came out through the wound. Through a perforation in the appendix three fecal concretions escaped. The edges of the opening were trimmed, and the opening was closed by interrupted silk sutures. The abdominal cavity was irrigated with warm water, and then syringed out with half a pint of one to one-thousand corrosive-sublimate solution. The wound was only partially closed, the remainder being packed with iodoform gauze reaching down between the coils of small intestine. No drainage-tube was used. Antiseptic dressing was applied and left on for two days, immediate improvement followed, and an uninterrupted and complete recovery took place.

A most brilliant proof of the success of early laparotomy in perforation of the cæcum has been given by McMurtry. The patient was a young physician, in whom the recurrent attacks of pain, and finally the swelling in the right iliac region, presented the usual symptoms of the onset of perityphlitis. An intestinal hemorrhage of thirty-two ounces marked the beginning of a spreading diffuse peritonitis, which rapidly developed, and the operation was performed after twenty-four hours, at the beginning of collapse. A lateral incision, four inches in length, over the cæcum revealed acute peritonitis on the loops of the surrounding small intestines, which were pushed aside with sponges, and the cæcum lifted out of the wound. On its anterior, external surface were two gangrenous perforations, respectively an inch and five-eighths of an inch in diameter, through the larger of which

a free escape of faecal matter had taken place. The edges of the perforation were trimmed with scissors and united with Lembert sutures of silk; the iliac fossa was washed out with one to forty carbolic-acid solution, and a large rubber drainage-tube was inserted deeply into the fossa. Immediate improvement followed. The drainage-tube was removed in two weeks, with subsequent perfect recovery.

The removal of the perforated appendix, with the permanent closure of its proximal portion, would naturally seem to be an important step in the modern, radical operation for perityphlitis, inasmuch as it prevents continued faecal extravasation, facilitates the rapid closure of the cavity, and does away with a permanent faecal fistula. The diseased appendix has been removed in a number of instances in later years, by Sands, Brenner, Hoffman, and others. Morton advises its excision in any case, especially when found inflamed or perforated during the operation for perityphlitis, while we have the opportunity. There is little doubt that its extirpation under these circumstances is desirable; but it is not always easy to accomplish. It is by no means certain that the appendix will present in the wound of incision, or that the caecum will be sufficiently movable to be brought out through the abdominal wound, so as to permit of easy access and inspection. In most of these cases the appendix is bound down by adhesions at the bottom of the deep abscess-cavity, where unnecessary manipulations should be avoided, for fear of opening into the general peritoneal cavity. Thus, as a rule, we shall have to content ourselves with the evacuation, careful washing out, and drainage of the peri-caecal collection of pus, without even seeing the diseased appendix. But when the diseased appendix is accessible it should be removed, and its proximal end closed, not by ligation, which has been successfully done, but by invagination, and Lembert sutures if possible.

*Median laparotomy* has been resorted to in a number of cases of diffuse peritonitis from perforations of the appendix. As a last resort, and the only hope in this desperate condition, the operation is uniformly considered justifiable, although the prospect of success is small. In twelve operations collected from the literature, the mortality was nearly ninety-two per cent. A boy of eighteen, after swallowing cherry-stones, was operated upon on the eighth day. Fetid faecal pus was found in the peritoneal cavity, more abundantly on the right side. A one to two-thousand sublimate solution was used for the irrigation of the peritoneal cavity. No drain was employed. In cases of this kind operators have usually drained, and probably this procedure was wise.

It is possible that even in this desperate condition more lives might be saved by early operation. From Fitz's statistics it appears that thirty-four per cent. of the patients with perforating appendicitis died during the first five days. To save some of these, operation might have been necessary as early as the third or even the second day. The difficulty of positive diagnosis, however, and the hope of limitation of the peritonitis may prove a barrier in the way of early operation.

I. EXTRAPERITONEAL OPERATIONS FOR ABSCESS.

OPERATOR.	AGE.	SEX.	DATE OF OPERATION.	PLACE OF INCISION.	CONTENTS OF ABSCESS.	RECOVERY OR DEATH.	REMARKS.
Parker	15	F.	14th day.	Over tumor.	Bloody serum and pus.	R.	
Leale	11	M.	"	One-third distance from anterior superior spine of the ilium on a line to umbilicus.	Fetid pus.	R.	
Kraekowizer	12	M.	11th day.	To transversalis fascia, divided upon director.	Gas and fetid pus.	R.	
Whitall	8	M.	14th "	Along Poupert's ligament.	Fetid pus.	R.	Incision to transversalis fascia. No pus with needle. Operation stopped. Pus escaped third day, fetid.
North	6	F.	20th "	"	2 ounces of pus.	R.	Eleven days after abscess, breast-pin escaped from wound.
Buck	12	M.	9th "	Upon trocar as director.	Fetid pus.	R.	Fifth day; sloughing of tissue. Seventh day, phosphatic concretion, size of pea.
Sands	13	M.	21st "	Incision.	Pus.	R.	
Proley	15	F.	19th "	Over tumor.	Fetid pus.	R.	
Kehey	11	M.	1 month.	Along Poupert's ligament.	"	R.	Operation abandoned. Incision to fascia. Needles found. No pus. Fifth day, several ounces of fetid pus escaped.
Gibney	4 1/2	M.	"	First, aspiration; later, incision.	"	R.	
Sands	11	M.	12th day.	Incision.	"	R.	
Sands	9	M.	13th "	"	"	R.	
Almon Clarke	13	M.	7th "	"	Fetid pus.	R. 15th d.	
Gibney	6	M.	34th "	Over tumor.	1 1/2 pints of pus.	R.	Incision one inch and a quarter, to transversalis fascia. Aspiration, abscess opened.
Woodward	6	F.	19th week.	Incision.	Pus, fecal matter.	R.	After eight weeks.
Van Buren	6	M.	"	"	Fetid pus and gas.	R.	After long time. Operated upon three times during two subsequent relapses in twenty days.
Gibney	8	F.	31st day.	"	Quart of fetid pus.	R.	In four weeks. Particles of food and ementa escaped from wound for several days.
Bridton	11	M.	10th "	Above Poupert's ligament.	Pus.	R.	
Proley	15	F.	13th "	"	"	R.	
Noyes	4 1/2	M.	21st "	"	Fetid pus, fluid feces.	R.	
Lange	10	M.	"	"	"	R.	
Lange	12	M.	1st month.	"	"	R.	
Gibney	12	M.	6th or 7th week.	Incision.	"	R.	Mistaken for hip-disease.
Demme	7	F.	"	"	"	R.	Glass beads escaped.
Erös	11	M.	"	"	"	R.	

## II. LATERAL LAPAROTOMY FOR ABSCESS.

OPERATOR.	AGE.	SEX.	DATE OF OPERATION.	OPERATION.	DEATH OR RECOVERY.	CONTENTS.	REMARKS.
Sands . .		Boy.	48 hours.	Vertical incision 1 inch above the outer part of Poupart's ligament, 4 inches long, to 1 inch below level of navel. Opening at base of appendix was closed with stitches through wall, not Lembert's sutures. Irrigation 1:1000 sublimate solution. Drain iodoform gauze.	R.	Air, fetid pus, 3 fecal stones.	No general peritonitis, but no limiting adhesions.
Homans .	11	M.	5th day.	Incision $1\frac{1}{2}$ inches above and a little posterior to anterior superior spine of ilium. On tender place. Healthy bowel met finger down through adherent intestines. Rubber drain.	R. in 3 weeks.	2 ounces of fetid pus.	No dulness. No swelling. No aspiration. Pulse 120. Temperature 102° F.

## III. LATERAL LAPAROTOMY FOR PERITONITIS.

OPERATOR.	AGE.	SEX.	DATE OF OPERATION.	OPERATION.	TREATMENT OF WOUND.	DEATH OR RECOVERY.	REMARKS.
Sands, 1888	Boy.	M.	48 hours.	Diffuse peritonitis, escape of air, 1 ounce of fetid pus, 3 fecal concretions.	Washing out and packing with iodoform gauze. No drainage-tube.	R.	
McMurtry, 1888 . . .	Adult.	M.	17th day.	Acute diffuse peritonitis. Gangrenous perforation of cæcum, fecal extravasation.	Washing out with 1:40 carbolic acid. Drainage.	R.	

## IV. MEDIAN LAPAROTOMY FOR PERITONITIS.

OPERATOR.	AGE.	SEX.	DATE OF OPERATION.	OPERATION.	TREATMENT OF WOUND.	DEATH OR RECOVERY.	REMARKS.
Cushing, 1883.	8	M.	14th day.	Peritonitis.	Washing out.	D.	Next day.
Mikulicz, 1883.	49	M.	5th "	Peritonitis.	Two drains.	D.	On fifth day.
Chaput, 1883 . . . .		M.	10th "	Obstructive peritonitis.	Washing out, drainage.	D.	Soon after operation.
Krönlein, 1884.	17	M.	2d "	Appendix removed.	Toilet, abdomen closed, no drain. 1:2000 sublimate on eventrated intestine, no drain.	D.	Two days after operation.
Krönlein, 1885.	18	M.	8th "	No perforation found. Fetid fecal pus, moist exudate right side.		R.	Disease came eight days after eating cherries with stones.
Polaillon, 1884.	19	M.	7th "	Appendix not seen.	Artificial anus.	D.	After ten hours. At autopsy perforation of the appendix.



IV. MEDIAN LAPAROTOMY FOR PERITONITIS—(Continued).

OPERATOR.	AGE.	SEX.	DATE OF OPERATION.	OPERATION.	TREATMENT OF WOUND.	DEATH OR RECOVERY.	REMARKS.
Poncet, 1885 .	Adult.	M.	4th day.	Appendix not seen at operation.	Drain.	D.	Same day.
Reignier, 1886.	16	M.	5th "	Perforation of cæcum.	.....	D.	After seven hours.
Bryant . . . .	49	M.	2d "	Three perforations of appendix.	Washing with 1:10,000 sublimate.	D.	After twelve hours.
Weir . . . . .	20	M.	7th "	Appendix removed.	Washing out, drainage.	D.	After six hours.
			24 hours after severe pain.				
Weir . . . . .	19	M.	5th day.	Appendix removed.	Eventration, glass drain.	D.	After four hours.
Cushing . . . .	8	M.	14th "	.....	Washing out, drainage.	D.	After one day.

BIBLIOGRAPHY.

J. T. H. Albers, Typholithiasis und Typhloosteosis, Archiv für Physiologische Heilkunde, Heft 4; Canstatt's Jahresbericht, 1851, Bd. iii. S. 267.

Aufrecht, Ueber die Paratyphlitis, Pathol. Mittheilung, Magdeburg; Virchow-Hirsch Jahresbericht, 1886, Bd. ii. S. 215.

Balzer, Gazette Médicale de Paris, 15-19-23-25.

H. Bamberger, Virchow's Handbuch der speciellen Pathologie und Therapie, Bd. vii. Abth. 1; Krankheiten des Darmcanals, Erlangen, 1864.

R. D. Barker, Journal of the American Medical Association, September, 1883, p. 275.

R. Bartholow, American Journal of the Medical Sciences, 1866, p. 351.

J. Bauer, Die Krankheiten des Peritonæums, v. Ziemssen's Handbuch der speciellen Pathologie und Therapie, Lief. 24, S. 345.

H. M. Biggs, Medical Record, June 30, 1888, p. 720.

Birch-Hirschfeld, Lehrbuch der pathologischer Anatomie.

Bossard, Ueber die Verschwärung des Würmfortsatzes, Diss., Zurich, 1869.

Bourdon, L'Union Médicale, No. 57, 1856.

Boys de Loury, Gazette Hebdomadaire, v. 28, 1885.

Brenner, Wiener Klinische Wochenschrift, No. 9, 1888.

Gurdon Buck, New York Medical Journal, October, 1865.

W. T. Bull, New York Medical Record, March 6, 1886, p. 265; New York Medical Journal, September, 1873, p. 240.

T. H. Burchard, New York Medical Record, December 11, 1880, p. 663; New York Medical Journal, January, 1881, p. 1.

Louis Bureau, Essai sur la Signification du Cæcum, Thèse, Paris, 1877.

John Burne, Medico-Chirurgical Transactions, 1836, vol. xx. p. 200.

Cless, Württ. Correspondenzblatt, 4-5, 1857.

Cushing, Boston Medical and Surgical Journal, 1886, No. 24.

Demme, Wiener Medizinische Blätter, 1884, No. 52.

Demme, XXIII. Medicinisches Berichte über die Thätigkeit des Jenner'schen Kinder-spitals in Bern, Virchow-Hirsch Jahresbericht, 1887, Bd. ii. S. 699.

Dupuytren, Leçons orales de Clinique chirurgicale, Paris, 1839.

Eisenschütz, Wiener Medicinische Presse, No. 11, 1866.

Erös, Jahrbuch für Kinderheilkunde, Bd. xix. No. 7, S. 328.

J. McF. Gaston, Journal of the American Medical Association, June 23, 1888, p. 777.

Gautier, Revue de la Suisse Romande, 1883, No. 3.

Gerlach, Zeitschrift für rationelle Medizin, 1847, vi. 12.

V. P. Gibney, American Journal of the Medical Sciences, January, 1881, p. 119.

- Goldbeck, Ueber eigenth. entz. Geschw. i. d. rechten Hüftbeingegegend, Worms, 1830.
- Hagen, Von der Entzündung und Perforation des Würmfortsatz, Erlangen, 1885.
- Virchow-Hirsch Jahresbericht, 1885-1886, Bd. ii. S. 198.
- Hancock, London Medical Gazette, 1848, N. S., vii. 547.
- Henoeh, Berliner Klinische Wochenschrift, 1886, No. 45, S. 781, Transactions of the Berlin Medical Society.
- Joseph Hoffman, Proceedings of the Obstetrical Society of Philadelphia, June 8, 1888; Journal of the American Medical Association, September 15, 1888.
- John Homans, Boston Medical and Surgical Journal, 1867; *ibid.*, April 29, 1886, p. 388.
- Husson and Dance, Répertoire d'Anatomie et de Physiologie, tome iv., 1827.
- Hilff, London Medical and Surgical Journal, 1832.
- F. König, Ueber die Bedeutung der Spalträume des Bindegewebes für die Ausbreitung der entzündlichen Prozesse, Volkmann's Sammlung Klinischer Vorträge, No. 57.
- Kraussold, Volkmann's Sammlung Klinischer Vorträge, 1887, No. 191.
- H. U. Krönlein, Archiv für Klinische Chirurgie, 1886, Bd. xxxiii. Heft 2, S. 507.
- Lange, New York Medical Journal, March 3, 1888, p. 247.
- Louyer and Villermy, Archives Générales, tome v., 1827.
- L. S. McMurtry, Journal of the American Medical Association, July 7, 1888, p. 9.
- Matterstock, Gerhardt's Handbuch der Kinderkrankheiten, 4, ii., Tübingen, 1880.
- Meigs and Pepper, A Practical Treatise on the Diseases of Children, Philadelphia, 1870.
- Monti, Archiv für Kinderheilkunde, Bd. vii. S. 161.
- Thomas G. Morton, Journal of the American Medical Association, January 21, 1888, p. 75; *ibid.*, June 16, 1888, p. 733.
- A. W. Nelson, Journal of the American Medical Association, July 21, 1888, p. 77.
- R. F. Noyes, Transactions of the Rhode Island Medical Society, vol. ii. part vi., 1882, p. 495.
- Oppolzer, Wiener Med. Wochenschr., 1863, xiii. 6-7, 1864, xiv. 12; Schmidt's Jahrbücher, cxxii. 49.
- Willard Parker, New York Medical Record, March 1, 1867.
- C. T. Peckham, Boston Medical and Surgical Journal, February 16, 1882, p. 158.
- William Pepper, Medical Bulletin, November, 1886, p. 341; Transactions of the Medical Society of Pennsylvania, 1888, p. 226.
- Perl, Berliner Klinische Wochenschrift, 1886, No. 45, S. 781.
- Pott, Jahrbuch für Kinderheilkunde, N. F., xiv. 157.
- Puchelt, Heidelberg. Klin. Annal., i. 571, viii. 524.
- J. Ransohoff, Journal of the American Medical Association, July 14, 1888, p. 40.
- D. Roger, Gazette Hebdomadaire, 2ème sér., 1864, ii. No. 44, p. 731.
- Henry B. Sands, New York Medical Journal, February 25, 1888.
- Savior, Lancet, February 21, 1880.
- N. Senn, Journal of the American Medical Association, June 23, 1888, p. 767.
- Silbermann, Jahrbuch für Kinderheilkunde, Bd. xviii. S. 420.
- Henry H. Smith, Journal of the American Medical Association, June 9, 1888, p. 707.
- J. Greig Smith, Abdominal Surgery, London, 1888, p. 719.
- Speck, Deutsche Klinische Wochenschrift, 40-45, 1867.
- Stokes, Encyclopædia of Practical Medicine, London, cited by Petrequin, Gazette Médicale de Paris, No. 28, 1837.
- Henri Taverney, Thèse, Paris, 1877.
- Tillmanns, Archiv für Klinische Chirurgie, Bd. xxvi. S. 103.
- A. Tissier, De la Pérityphlite, Paris, 1865.
- Toft, Om Ulceration og Perforation af Processus Vermiformis, Kjöbenhavn, 1868.
- Treves, Intestinal Canal in Man, London, 1885.
- Volz, Schmidt's Jahrbücher, 1857, Bd. xcvi. S. 40.
- R. F. Weir, New York Medical Record, June 11, 1887, p. 652.
- C. E. With, Peritonitis Appendicularis eller Den Ved Ulceration og Perforation af Appendix Ileo-cæcalis fremkaldte, Peritonitis, Kjöbenhavn, 1879.

# CONGENITAL ABNORMALITIES OF THE INTESTINE.— MALFORMATIONS, INJURIES, AND DISEASES OF THE RECTUM AND ANUS.

BY HENRY R. WHARTON, M.D.

---

## CONGENITAL ABNORMALITIES OF THE IN- TESTINE.

### ABNORMALITIES OF THE SMALL INTESTINE.

CONGENITAL malformations of the small intestine occur with much less frequency than those of the rectum and anus. E. Theremin,<sup>1</sup> who has carefully investigated this subject, states that at the Vienna Foundling Hospital only two cases of congenital occlusion of the small intestine were recorded among 111,451 patients, and that at the St. Petersburg Foundling Hospital only nine examples of this malformation were observed in 150,000 children; in the Foundling Hospital of Moscow and Prague no cases were recorded.

Absence of the whole or a large portion of the small intestine is generally met with in ill-developed acephalic monsters.

Congenital occlusion of the small intestine occupies most frequently the duodenum near the point at which the bile-duct and the pancreatic duct open, or at the point where the duodenum becomes jejunum under the transverse mesocolon; malformations of the ileum, also, may exist at any portion of its length, but are most common near the ileo-cæcal valve, or a short distance above it, where the ductus omphalo-mesentericus is given off.

The malformation may consist of a stenosis or atresia of the gut; or the bowel may terminate in a cul-de-sac at the point of obstruction, beyond this point again beginning in a cul-de-sac, and the remaining portion of the intestine may be well developed; or the bowel may have a diverticulum given off which attaches it to the abdominal walls, and this may contain a fistula opening upon some portion of the body; the deformity may also consist of an abnormal shortness of the intestinal canal.

Bodenhamer<sup>2</sup> mentions cases in which both the rectum and the colon

---

<sup>1</sup> Deutsche Zeitschrift für Chirurgie, 1877, Bd. viii.

<sup>2</sup> Congenital Malformations of the Rectum and Anus, p. 290.

were wanting and the small intestine terminated at the umbilicus, in the iliac fossa, or at some portion of the surface of the abdomen.

Mr. H. Thomas<sup>1</sup> reports the case of a child who lived four days, in whom, upon post-mortem examination, there was found a congenital absence of the jejunum, the ileum, and a large portion of the colon. In this case there was no trace of any portion of the small intestine except the duodenum, nor of the cæcum, nor of the ascending or transverse colon. The descending colon commenced by a blind extremity, which lay in front of the left kidney and was continued as a sigmoid flexure to terminate in the vagina.

Holmes<sup>2</sup> mentions two cases of congenital occlusion of the small intestine in which the diagnosis was satisfactorily established, and Therman<sup>3</sup> also reports a number of cases.

A case illustrating this form of congenital malformation of the small intestine is reported by Dr. W. Craig,<sup>4</sup> in which the autopsy in the case of a child who lived seventy-two hours showed an obstruction of the small intestine at the upper fifth of the ileum. The intestine was distended above the point of obstruction, and upon opening the bowel it was found that it ended in a cul-de-sac; further examination of the gut beyond the point of obstruction showed that the intestine began in a cul-de-sac, and the intervening space between these two pouches was occupied by a band of fibrous tissue. The gut below the obstruction contained meconium, and the colon, rectum, and anus were well developed. Mr. W. Thomas<sup>5</sup> reports a somewhat similar case, in which the jejunum terminated in a cul-de-sac at a point thirty-two inches from the pylorus. In these cases it was remarked that if the continuity of the intestinal canal had ever existed it must have been very early in fetal life. Dr. J. F. Goodhart<sup>6</sup> reports the case of a child who died four days after birth, in whom the intestine beyond the duodenum was contracted to the size of a goose-quill.

Among the congenital malformations of the small intestine may be mentioned that condition known as Meckel's diverticulum, which consists of a cylindrical or flask-shaped appendage attached to the ileum about a metre or more above the ileo-cæcal valve: it is a remnant of the omphalo-mesenteric duct, and it may occur in a variety of forms.<sup>7</sup>

Its presence, according to Birch-Hirschfeld,<sup>8</sup> is to be regarded as due to an arrest of development of the bowel in one of its steps, and the frequency of its occurrence is variously estimated. Osler<sup>9</sup> mentions the presence of

---

<sup>1</sup> British Medical Journal, 1884, p. 111.

<sup>2</sup> Surgical Diseases of Children, p. 180.

<sup>3</sup> Loc. cit.

<sup>4</sup> Edinburgh Medical Journal, vol. xxvii. p. 146.

<sup>5</sup> British Medical Journal, November 13, 1886.

<sup>6</sup> Transactions of the London Pathological Society, vol. xxxi. p. 114.

<sup>7</sup> Ziegler's Pathology, sect. i. p. 278.

<sup>8</sup> Pathologische Anatomie, S. 853.

<sup>9</sup> Intestinal Diverticula, Annals of Anatomy and Surgery, vol. iv. No. v., November, 1881.

twelve cases of this malformation in five hundred and eighty post-mortem examinations; Treves<sup>1</sup> found no case of it in one hundred autopsies.

In the most marked form of this malformation there exists a fissure in the abdominal walls above the umbilicus, through which the ileum opens and through which feces escape; the bowel below may be narrower than normal. In other cases the ileum may communicate directly with the umbilical opening by means of a patent omphalo-mesenteric duct, the bowel below being well developed: two cases of this nature are reported in Guy's Hospital Report for 1843. In another variety of this malformation the ventral fissure may be closed, and a blind process of the ileum may be attached to the umbilicus by means of a fibrous cord, the remains of the obliterated omphalo-mesenteric duct.

Another form of this defect manifests itself by the presence of a reddish tumor covered by mucous membrane, occupying the position of the umbilicus, which has been variously described by different authors. Holmes speaks of it as a *warty tumor of the umbilicus*, Pearce-Gould terms it *congenital mucous polypus of the umbilicus*, and it has been described by other writers as *adenoma of the umbilicus*. In structure it is similar to the mucous membrane of the intestine.

In this connection should be mentioned those structures, closely allied to congenital diverticula of the intestine, known as *entero-cystomata*, which are closed sacs filled with liquid and exhibiting the same structure as the walls of the bowel. Two forms may be distinguished: (1) cysts due to obstruction and sacculation of portions of an otherwise normally developed intestine; (2) cysts due to some abnormality of development in the fetus. These latter may be portions of the intestine of a rudimentary twin, and therefore teratoid in character, or may depend on the closure and separation of an anomalous diverticulum such as Meckel's.<sup>2</sup> False diverticula consisting of pouches made up solely of mucous membrane and peritoneum, and varying from the size of a pea to that of a walnut, may be found in some cases throughout the whole course of the small and large intestine. These pouches are often seen at post-mortem examinations, and appear to be productive of no symptoms during life unless they become ulcerated or perforated or become attached to some of the viscera.

Ball<sup>3</sup> mentions a case, reported by Dr. Platt, of a girl aged nine years who died of intestinal obstruction, and in whom at post-mortem examination was found a swelling in the rectum which was probably of this nature.

#### CONGENITAL MALFORMATIONS OF THE LARGE INTESTINE.

Congenital malformations of the large intestine, like those of the small intestine, are met with much less frequently than those of the rectum and anus, and may involve the colon, the sigmoid flexure, or the cæcum.

<sup>1</sup> Anatomy of the Intestinal Canal, 1885.

<sup>2</sup> Ziegler's Pathology, sect. i. p. 279.

<sup>3</sup> Diseases of the Rectum and Anus, p. 399.

Atkin<sup>1</sup> reports the case of a child who died two days after birth, in whom at the autopsy the rectum and colon were found to be rudimentary, smaller than an ordinary quill. In this case attention was called to the fact that the parts had remained in the condition in which they are in the early embryo.

It has also been observed in some of the cases of congenital occlusion of the small intestine, that the colon was rudimentary, and this is markedly the case in those forms of Meckel's diverticulum in which a faecal fistula exists between the ileum and the fissure above the umbilicus, or where a faecal fistula exists between the small intestine and some portion of the abdomen.

The recent investigations of Treves<sup>2</sup> have shown that the mobility of the caecum and colon, owing to the arrangement of their peritoneal attachments, is much greater than was formerly supposed. Lockwood<sup>3</sup> reports a number of cases in which the caecum and colon occupied anomalous positions, and one in which the caecum occupied the right hypochondriac region beneath the liver, and in the same case the descending colon was double. The frequent occurrence of the caecum as part of the contents of a hernial sac has been observed, and Wright<sup>4</sup> reports seven cases of herniotomy in children in which the contents of the sac consisted of this portion of the intestine. Cases of double caecum have also occasionally been met with.

These various congenital malformations of the small and large intestine are probably largely to be attributed to accidents in development, due to the complicated disposition of the intestinal tract of the embryo, and it is also possible that fetal peritonitis plays an important part in the production of these deformities, although the fact of its existence cannot be demonstrated in all cases. There is of the opinion that many of the malformations are due to changes in the peritoneum which have taken place early in fetal life.

**Symptoms.**—The symptoms resulting from congenital malformation of the large or small intestine are simply those of intestinal obstruction in a more or less marked degree, depending upon the completeness of the obstruction, and all observers are agreed as to the absence of definite symptoms which could enable the surgeon to locate accurately the seat of the lesion. The vomiting of whitish mucus, with obstruction of the bowels, in the case of a new-born child is a symptom which points to an occlusion high up in the small intestine, but if the occlusion exists in the jejunum or the ileum this may be replaced by the vomiting of meconium, and in such a case the symptoms would in no wise differ from those consequent upon an occlusion situated at the lower end of the intestinal canal.

If a faecal fistula exist, the symptoms of obstruction will not usually be so

<sup>1</sup> London Lancet, January 31, 1885, p. 203.

<sup>2</sup> Loc. cit.

<sup>3</sup> British Medical Journal, September 23, 1882.

<sup>4</sup> *Ibid.*, March, 1887, p. 506.

marked, and its position may be some guide to the surgeon as to the situation of the intestinal malformation.

**Diagnosis.**—The diagnosis of the exact location of the malformation of the small or the large intestine cannot in many cases be definitely made out, but in the case of a newly-born child in whom obstruction of the bowels exists, a careful examination should be made of the rectum and anus, to exclude the presence of malformation in this region. If the anus is present, a catheter should be passed and water injected, and if there be no malformation low down in the canal the return stream will bring away meconium: it can then be inferred that the obstruction exists in a higher portion of the intestinal canal. The vomiting of whitish mucus, before mentioned, is also a point in favor of the obstruction being high up in the intestinal canal. Careful palpation and percussion of the belly may disclose the presence of a tumor, or elicit dulness above the seat of obstruction, which may give the surgeon some idea as to the situation of the malformation.

If a faecal fistula exists at the umbilicus or at another point of the abdomen, the diagnosis of the seat of the malformation is not so difficult; but, upon the whole, I am of the opinion that in most cases an exact diagnosis as to the seat of the malformation is impossible.

**Prognosis.**—The prognosis of these cases is, unfortunately, a matter of more certainty. Many cases are necessarily fatal from the start,—for instance, those in which the occlusion exists in the duodenum or high up in the jejunum; but, on the other hand, if a faecal fistula exist not too high up in the intestinal canal, or if the occlusion be not complete, the patient may live for months or years; but complete occlusions are generally fatal within a few days unless relieved by operative treatment.

**Treatment.**—As regards the treatment of the various forms of malformation of the small or the large intestine, unfortunately the result of such treatment in the cases recorded up to the present time does not present a very encouraging picture; but with the improved manner of wound-treatment due to the antiseptic method now very generally adopted a larger share of successful cases may fairly be looked for.

The deaths after these operations have generally been due to shock or peritonitis, and I feel certain that the former of these causes of death may in many cases be averted by careful attention to the conservation of the bodily heat of the patient both at the time of the operation and afterwards, and that the latter complication may best be guarded against by a rigid adherence to the most exact details of the antiseptic method of operation and wound-treatment.

As before stated, the diagnosis of the exact seat of the lesion is in many cases so obscure, and the symptoms calling for relief are so urgent, that I feel sure that the surgeon, under the circumstances, would consider himself fully justified in undertaking an exploratory operation which should offer even a slight chance of affording relief or of bringing about a cure in a case which, left to itself, must necessarily terminate fatally.

I think a median laparotomy, on the whole, unless some definite symptoms exist which point to the exact seat of the obstruction, should be the operation selected.

If this operation is decided upon, and the abdomen is opened and explored, and the malformation is found to be situated in the duodenum or high up in the jejunum, the case must be abandoned as a hopeless one, unless it be found possible to excise the occluded portion of the bowel and suture together the cut ends of the gut, thus establishing the continuity of the intestinal canal by means of enterorrhaphy; or the operation of intestinal anastomosis, as practised by Senn and Abbe, might be employed with advantage. If the occlusion be found due to a membranous septum, the gut may be incised and the septum exposed and perforated, so as to re-establish the continuity of the canal; the wound in the intestine through which this is done should then be closed by the introduction of Lembert's sutures, and the abdominal wound closed in the usual way.

This, of course, in a child of such tender age would be an operation of difficulty, and one attended by great shock, and would hold out a very slender chance of success; nevertheless, considering the necessarily fatal termination of such cases if left unrelieved, I think it is a procedure which should be adopted. If upon exploration the occlusion be found to exist low down in the jejunum or the ileum, or in the large intestine, the obstruction may be divided or excised, and the ends of the intestine may be brought to the edges of the abdominal wound and secured there by sutures,—in other words, an artificial anus may be established; and, if the patient survives, the continuity of the intestinal canal may be re-established by an operation undertaken at a later period, intestinal anastomosis probably being the best operation to employ. If a fecal fistula exists, as obtains in some cases of Meckel's diverticulum, and the child does not exhibit symptoms of intestinal obstruction, an operation may be deferred until such symptoms appear, or until the child has attained an age when an operation to establish the continuity of the intestinal canal may be undertaken with more hope of success. If in such a case the symptoms of obstruction are marked or are increasing, the fistulous opening may be carefully dilated or incised, and, if relief be obtained, further interference may be postponed until a later period.

In cases of Meckel's diverticulum with a tumor at the umbilicus where no symptoms of obstruction are present, the base of the tumor should be ligated, and the portion of the tumor in advance of the ligature excised, or destroyed with the actual cautery.

Dr. Holt<sup>1</sup> reports a case of this nature treated successfully by the application of the ligature, and I have recently had under my care such a case in which I applied a ligature, with an equally satisfactory result.

---

<sup>1</sup> New York Medical Record, April 21, 1888, p. 431.



## CONGENITAL MALFORMATIONS OF THE RECTUM AND ANUS.

Congenital malformations of the rectum and anus constitute a most interesting class of deformities, not only as regards their production, but also as regards their treatment; and it is essential that all medical men should be familiar with the different varieties of this malformation, as well as with their treatment, for in many cases the saving of life depends upon the promptness with which surgical aid is rendered.

The number of children born with congenital defects of the rectum and anus is small. Zöhrer, of the Vienna Lying-in Hospital, and Collins, of the Dublin Lying-in Hospital, in a joint collection of 66,654 deliveries, found only three cases of imperforate rectum;<sup>1</sup> other observers give the proportion of children born with this defect as about one case in every five thousand births.

### PATHOLOGY.

Malformations of the rectum and anus unquestionably result from arrested development of the parts in early fetal life, and a glance at the development of the intestinal canal will show the method of production of the deformity in some of its various forms.

At its earliest commencement the alimentary canal consists of a simple sac or bag, developed from the innermost layer of the blastoderm, partly within and partly without the body, and in process of development this communication between the two portions of the sac is shut off, and the portion within the abdomen consists of a simple tube—the mesenteron—which terminates at the anterior extremity of the embryo in a blind pouch, while at the posterior extremity a similar pouch is formed.

The cul-de-sac at the anterior extremity of the embryo comes in contact and communicates with an invagination of the epiblast which is called the stomodæum, while a similar depression of the epiblast at the posterior extremity of the embryo, named the proctodæum, forms the anal orifice and communicates with the mesenteron.

The greater portion of malformations of the rectum and anus are due to the latter stages in the process just described being incomplete, or, in other words, to an arrested or irregular development of the proctodæum or mesenteron.

The termination of the rectum in the genito-urinary tract is due, in addition to the arrest of development just mentioned, to a similar arrest of development in the perineal septum which separates the rectum from the genito-urinary tract, both in the early life of the embryo having a common orifice. The failure of development of the perineal septum explains the frequency of cases of imperforate rectum and anus in which there is a communication between the intestinal tube and the genito-urinary tract.

<sup>1</sup> Ball, Diseases of the Rectum and Anus.

## CLASSIFICATION.

The best classification of malformations of the rectum and anus is that adopted by Bodenhamer,<sup>1</sup> and is as follows :

- I. Congenital narrowing of the rectum or anus without complete occlusion.
- II. Complete occlusion of the anus by a membranous diaphragm or by well-formed skin.
- III. The anus is absent, and the rectum ends in a blind pouch at a point more or less distant from the perineum.
- IV. The anus is normal in appearance, but ends in a cul-de-sac, and the rectum ends in a blind pouch at a variable distance above this point.
- V. The anus is absent, and the rectum ends by a fistula at any point of the perineum or sacral region.
- VI. The anus is absent, and the rectum ends in the vagina, bladder, or urethra.
- VII. The anus and rectum are normal, but the ureters, vagina, or uterus open into the rectal cavity.
- VIII. The rectum is totally absent.
- IX. The large intestine is totally absent.

## I. CONGENITAL NARROWING OF THE RECTUM OR ANUS WITHOUT COMPLETE OCCLUSION.

Of this variety of malformation few cases are recorded (Fig. 1), but, according to Bodenhamer, it is more common than is generally supposed, and escapes notice if the narrowing is not sufficient to produce marked

FIG. 1.

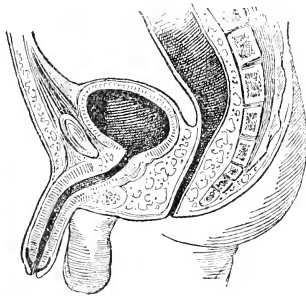

Narrowing of the rectum or anus without complete occlusion.

symptoms of obstruction, and probably in many cases of this nature in which the stenosis is not extreme the efforts of the child in passing the feces bring about the necessary amount of dilatation. The condition may not be detected for some time, as the stenosis may not be sufficient to prevent the free escape of the semi-fluid feces of infant life, and it is only as the child becomes older and the feces become more consistent that accumulation takes place in the rectum and attention is directed to the deformity.

Dr. T. P. Henry<sup>2</sup> reports the case of a child three days old who suffered from a congenital stricture or narrowing of the rectum one and a half inches above the sphincter. In this case the narrowing was so marked that a small probe could with difficulty be passed through it.

<sup>1</sup> Treatise upon Congenital Malformations of the Rectum and Anus.

<sup>2</sup> British Medical Journal, May 12, 1888.

In other cases the calibre of the rectum or anus may be diminished by the presence of a perforated membranous septum, or by one or more folds of the mucous membrane, which allow only an imperfect escape of faecal matter.

**Symptoms.**—The symptoms of this form of malformation, if well developed, would be those arising from the imperfect escape of faecal matter,—straining, with the passage of little faeces, pain, and swelling of the abdomen.

**Diagnosis.**—The diagnosis is made by a careful examination of the rectum, which will disclose the nature of the deformity.

**Prognosis.**—The prognosis in this variety of rectal malformation is generally favorable.

**Treatment.**—The treatment of this variety of congenital stenosis is best conducted by gradual dilatation, and the prospect of a permanent cure by this method of treatment is very encouraging. It may be carried out by the daily introduction into the bowel of graduated bougies, or by the introduction of the oiled index finger of the mother or the nurse, which is by far the best of all bougies for this purpose.

If the occlusion be due to a membranous band, as in a case reported by Cripps,<sup>1</sup> where a band extended from the tip of the coccyx to the perineum or to one or more hypertrophied folds of the mucous membrane, the obstructing band or folds should be divided, and dilatation, either instrumental or digital, should be employed for some time afterwards, to bring about full dilatation of the parts.

## II. COMPLETE OCCLUSION OF THE ANUS BY A MEMBRANOUS DIAPHRAGM OR BY WELL-FORMED SKIN.

The closure of the anus in this form of malformation may be by a diaphragm of greater or less thickness, composed of mucous membrane or skin (Fig. 2), and its presence is not incompatible with the development of the sphincter and other portions of the termination of the rectum. It appears to be due to an adhesion or skinning over of the surface of the anus, the rest of the proctodæum being normally formed.

**Diagnosis.**—The diagnosis of this malformation can be made by observing that the child passes no faeces and that the region of the anus bulges when straining takes place, and fluctuation in the distended rectum may also be detected.

**Treatment.**—The treatment of this variety of malformation is also simple and satisfactory. It consists in making a crucial incision at the

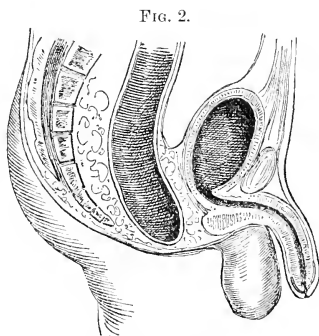

Complete occlusion of the anus by a membranous diaphragm or by well-formed skin.

<sup>1</sup> Diseases of the Rectum, p. 25.

position of the anus, opening the rectal pouch, and evacuating the fæces, and in trimming off the edges of the mucous membrane or skin. The wound should then be dressed with a pad of oiled cotton or lint. The subsequent management of the case consists in keeping the anus well dilated for some time, to prevent cicatricial contraction.

### III. THE ANUS IS ABSENT, AND THE RECTUM ENDS IN A BLIND POUCH AT A POINT MORE OR LESS DISTANT FROM THE PERINEUM.

In this variety of malformation the rectal pouch may descend well down into the pelvis and may terminate near the skin, or it may end high up in the pelvis and the space between it and the perineum may be filled with cellular tissue, or in other cases a distinct fibrous cord can be traced from the termination of the rectum to the skin. (Fig. 3.)

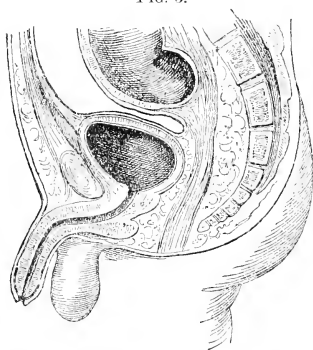

The anus is absent, and the rectum ends in a blind pouch at a point more or less distant from the perineum. (After Mollière.)

**Symptoms.**—The symptoms of this deformity are very manifest: obstruction of the bowels, pain, and violent straining; the abdomen becomes distended, and fecal vomiting is apt to occur unless the obstruction is relieved.

**Diagnosis.**—Inspection shows the absence of the anal orifice, and, if the rectal pouch descends well down into the pelvis, the perineum may bulge upon the straining efforts of the child, and in certain cases fluctuation may be elicited by palpation of the abdomen and perineum. Care should be taken to ascertain whether there is any communication between the rectal cul-de-sac and the genito-urinary tract.

**Prognosis.**—The prognosis of this form of malformation, as well as of all other forms in which there is complete occlusion, is necessarily very unfavorable, the patients generally perishing within a few days, of intestinal obstruction; although a few cases have been reported in which life has been prolonged for a few weeks, the patient being subject to periodical attacks of fecal vomiting. Cripps<sup>1</sup> mentions the case of a child two days old who was brought to St. Bartholomew's Hospital with an imperforate rectum. The parents refused to have any operation performed, and took the child away. The case was brought back to the hospital a month later, and it was then observed that the child appeared fairly nourished, but that the belly was much distended; the parents stated that it had fecal vomiting

<sup>1</sup> Loc. cit., p. 28.

three times a day. These exceptional cases are so rarely seen that they in no way affect the general prognosis.

In this connection may be mentioned the advisability of operating upon cases of imperforate rectum and anus unless the imperfection is in the immediate neighborhood of the anus: if the latter condition does not obtain, many surgeons are opposed to any interference, which can but leave the child with a contracted anus or an opening in the groin or loin, with its consequent annoyances; but, on the other hand, as will be seen in speaking of the results of the operation, many cases live in comfort for many years. For myself, I feel that it is the duty of the surgeon to operate and save the child from an immediate risk of a most distressing mode of death by intestinal obstruction, even with the chance of leaving the patient with an anus in an abnormal position; and I am of the opinion that the surgeon should urge the performance of the operation in a case of this nature as much as he should tracheotomy or intubation of the larynx in a case of croup suffering from obstructive dyspnoea, or herniotomy in a case of long-standing strangulated hernia; in all these cases the surgical interference relieves the immediate tendency to death and gives the patient a chance for his life.

We are frequently met, on the other hand, by the difficulty of obtaining the consent of the parents, who often express the opinion that they would prefer to have the child die rather than have it live with an anus in an abnormal position. In such cases the surgeon should state fairly and honestly the possible results of the operation, and, if the parents still refuse their consent, he has done his duty and has no further responsibility in the case.

**Treatment.**—In the treatment of this variety of malformation, and, in fact, of all the forms of imperforate rectum in which complete occlusion exists, the duty of the surgeon is very clear: he should as soon as possible attempt to reach the rectal pouch by perineal incision. I think the earlier this is attempted the better, for delay in operating certainly conduces largely to a fatal result, and I cannot subscribe to the opinion of those who advise delay until the rectum is distended with faeces and gas, which may make the position of the rectal pouch more apparent, but which is not unattended with the risk of rupture of the intestine and exhaustion of the patient. Indeed, it has been shown that by delay the meconium becomes reduced in bulk through the absorption of the fluids.

That rupture of the intestine is a possible result of delay in operating is clearly shown in the history of the case depicted by Fig. 7, and therefore I cannot too strongly urge the importance of early operation in cases of this nature. It is well to remember that the rectum in children descends in the hollow of the sacrum and is close to the bone, and except at its upper portion is uncovered by peritoneum posteriorly: in front its peritoneal investment descends to a much lower level, and its close relation in this aspect to the genito-urinary tract is an additional reason for the selection of the posterior region for exploratory operation.

*Puncture with a Trocar and Canula.*—Puncture of the rectal pouch with a trocar and canula, introduced through the perineum, was formerly advised, and by its use I have seen the rectum reached and meconium evacuated; but it is generally found necessary to enlarge the wound made by the instrument to secure the free exit of fecal matter, so that I do not see that its use possesses any advantages over the perineal incision, and I think it has decided disadvantages, for the rectal pouch may be entirely missed by the trocar, and important structures may be injured by its blind introduction.

A number of cases are referred to by Cripps<sup>1</sup> in which examination after death showed that the trocar had failed to enter the rectal pouch,—as happened in a case in my own practice, in which the parents of a child with imperforate rectum of the fourth variety refused the perineal operation, which I first suggested, but agreed to my attempting to reach the bowel by a puncture with a trocar. I failed to reach the rectum, and the child died in a few hours. Upon making a post-mortem examination, I found that the rectum ended in a blind pouch about two inches from the perineum, and that my trocar had passed between the rectal pouch and the sacrum. In this case I think it would have been entirely feasible to open the bowel from the perineum.

At the present time the weight of surgical opinion is decidedly against the operation of puncture with a trocar in cases of imperforate rectum, except where all other forms of operation are refused.

*The Perineal Operation.*—If the perineal operation be decided upon to reach the rectal pouch,—and I think it is now generally considered the best operation, since if successful it has the advantage of leaving the patient with an anus in the normal position, and often with fair control of the bowels, for the anal sphincter is often well developed in spite of the malformation of the rectum,—the child should be placed in the lithotomy position, and whether an anæsthetic be administered or not will depend upon the judgment of the surgeon; for myself, I prefer not to give an anæsthetic to so young a patient. An incision is now made in the median line of the perineum, and this incision should be carried from behind the root of the serotum to the coccyx. The tissues should be divided slowly, and any bleeding vessels should be secured as they show themselves. The surgeon should constantly explore the wound with his finger, to find, if possible, the bulging of the rectal pouch, and should remember to make the deepest incisions posteriorly. In a female child some information may be elicited as to the position of the rectum during the operation, by exploring the vagina with the finger or a probe. If the cord-like mass of fibrous tissue in which the rectum sometimes terminates is seen or felt, it may form a valuable guide as to the position of the rectal pouch.

Nearness of the tuberosities of the ischium is a sign of absence of the rectum; and if it is found that the vagina or the bladder fills up the con-

<sup>1</sup> Loc. cit., p. 41.

cavity of the sacrum, it is an indication of a high termination of the rectal pouch.

The incision may be carried with safety to a depth of an inch and a half or two inches. When the rectal pouch is reached, it should be incised, and, when the meconium has escaped, the wound in the rectum should be sufficiently enlarged, and then, if possible, its edges should be brought down and sutured to the skin of the perineal wound, care being taken, by passing the sutures deeply and by introducing a drainage-tube, to leave no pocket around the bowel for the accumulation of discharges.

The suturing of the edges of the bowel to the skin may be found impossible in certain cases if the rectum terminates high up in the pelvis, but if it can be accomplished it is a most important procedure, and one which diminishes largely the amount of contraction in the newly-formed anus. If it is found impossible to bring down the edges of the rectal wound to the skin, a large flexible catheter or a metallic tube may be introduced and held in place by tapes; but it is almost impossible to keep it in position, as it is apt to be displaced by the straining efforts of the child.

A very valuable modification of this operation has been suggested and practised by Verneuil,<sup>1</sup> and has been very favorably commented upon by those who have made use of it,—namely, excision of the coccyx in the early part of the operation, which greatly facilitates the search for the gut, and, in case it is found, enables the surgeon more readily to attach the edges of the rectal pouch to the skin.

Vincent<sup>2</sup> has suggested the following procedure in cases of this nature, which consists in making an incision five centimetres in length on the natural site of the anus, its posterior extremity passing the tip of the coccyx by one centimetre. The rectal pouch is found and mobilized by the use of the finger and director, and the anterior face of the coccyx and sacrum is also exposed. By this plan no organ can be wounded, and the rectal pouch, which is recognized by its dark color, is more surely reached. When it is found and its adhesions are ruptured by the finger, it is brought down to the surface of the skin by gentle traction without being opened. The next step is to determine the level of insertion of the rectal pouch. If the bottom of the pouch comes to the skin without any traction, all is well; but if, on the contrary, it has to be dragged down to this level, the perineal incision must be prolonged beyond the coccyx and along the side of the sacrum until the rectal pouch rests easily on the level of the incision and remains there without traction. Two semilunar flaps of skin are then removed, causing an ovoid loss of substance with its long axis antero-posterior, with the object of preventing subsequent retraction of the anal orifice. The internal sphincter must be relied upon to prevent incontinence of fæces, and in none of

<sup>1</sup> Medical Times and Gazette, July 25, 1873.

<sup>2</sup> Annual of the Medical Sciences, 1888, vol. ii.

Vincent's cases has this occurred. The sutures are placed in two consecutive planes. If the rectal pouch is intact, its lowest part should pass two or three centimetres beyond the cutaneous wound, and should be fixed to the borders of the wound by catgut sutures. The pouch is then opened, and after the meconium has escaped, a constant flow of antiseptic fluid being maintained, the free edges are pared off, and the gut is attached to the skin of the margin of the wound by a row of fine silk sutures. If the pouch has been torn during the other steps of the operation, the first row of sutures is placed so that the knots shall be inside of the new anus. The second row is passed as in the previous case, and in this manner all possibility of infiltration of the peri-rectal cellular tissue is obviated. This procedure overcomes the tendency on the part of the rectum to ascend when the sutures relax, the mucous border remains, and the ablation of the skin secures the permanence of the artificial anus.

The dressing of the wound should consist in dusting the parts with iodoform, and in keeping applied a pad of cotton moistened with some antiseptic solution, to collect the discharges; this pad should be changed as often as it becomes soiled, and the wound should also be kept clean by the use of a weak solution of bichloride of mercury or carbolic acid.

If the surgeon has carried his dissection up into the pelvis as far as he considers it safe, an inch and a half or two inches, and has failed to reach the rectal pouch, he should now consider the advisability of abandoning the attempt to reach the gut through the perineum, and should endeavor to open the large intestine either in the left groin,—Littre's operation,—or in the left loin behind the peritoneum,—Amussat's operation,—or in the right groin,—Huguier's operation.

The objections to the performance of Amussat's operation in children are the difficulty of finding the descending colon, which is much more movable than in the adult by reason of the length of its peritoneal attachment, and the fact that the relatively large size of the infant's kidney limits the space in which the operation is performed. Huguier's suggestion to make the incision in the right groin to open the sigmoid flexure of the colon, grounded upon the observation that this portion of the intestine is frequently in young children curled over so as to assume this position, has not generally been accepted. He also points out the fact that if the sigmoid flexure is not met in this position, the caecum or some other part of the large intestine may be reached and opened. But experience shows that the sigmoid flexure occupies much more frequently the left side, for Boureart,<sup>1</sup> in one hundred and fifty post-mortem examinations made to elucidate this point, found the sigmoid flexure in its normal position in one hundred and seventeen cases: so that I think it is clearly shown that the opening in the right groin is not to be recommended. I think that all authorities are now agreed that Littre's operation, or laparo-colotomy in the left groin, which opens the bowel near

<sup>1</sup> Holmes, Surgical Treatment of Children's Diseases, p. 179.



its natural termination, is the best procedure to adopt when it is found impossible to perform the perineal operation.

If the surgeon decides upon this operation, he should make an incision from one and a half to two inches in length, half an inch above and parallel with Poupart's ligament, beginning at a point opposite the junction of the middle with the outer third of this structure. Or, as suggested by Ball, an incision of sufficient length following the line of the *linea semilunaris*, stopping just short of Poupart's ligament, may be substituted for the former incision. The skin and muscular layers being cut through, the fascia transversalis and peritoneum may be pinched up together, and a small opening made in them, through which a director should be passed, and the two can be then divided with one incision. At this step of the operation the edges of the wound may be everted, and the peritoneum secured to the edges of skin.

It is sometimes difficult for the surgeon to determine whether the bowel presenting in the wound is small or large intestine; this can be ascertained by gently drawing outward the coil: if it be the small intestine it can be drawn out with ease, and the mesentery will show that it is not the portion of the bowel which is sought for, whereupon it can be replaced. On the other hand, the large intestine cannot be so readily drawn out, and its mesocolon, if it have one, will be found attached to the left side.

When the surgeon has satisfied himself that the presenting gut is large intestine, he should before opening it secure the bowel to the edges of the wound by several sutures of fine silk or catgut. In making these sutures a curved needle should be passed through the skin and parietal peritoneum near the edge of the wound and should then transfix a portion of the bowel, after which the needle should again be passed through the peritoneum and skin: several sutures should be applied on each side of the incision. The gut may now be incised to a sufficient extent, and the meconium allowed to escape, care being taken to prevent its entrance into the peritoneal cavity.

Before dressing the wound the surgeon may explore the gut with his finger or with a flexible catheter, to locate the termination of the rectal pouch with reference to its proximity to the perineum, and if it is found that it approaches the perineum he can at this time deepen the perineal incision on a guide introduced through the artificial anus just made, or he can postpone to a later period the attempt to form an anus at its normal position.

Attempts to establish an anus in the perineal region immediately after the performance of colotomy in these cases are attended with so much danger, and have been so unsuccessful, that I think the judicious surgeon will rest contented with the relief which has been afforded by colotomy. Mr. Owen<sup>1</sup> attempted this procedure in two cases three months after colotomy,

---

<sup>1</sup> Surgical Diseases of Children, p. 309.

with a fatal result in both. Dr. Byrd<sup>1</sup> has reported a successful case; and Krönlein,<sup>2</sup> in a case of imperforate rectum, in which the anus terminated in a narrow pouch two and a half centimetres long, succeeded in establishing the continuity of the gut seven months after the performance of colotomy. If, however, the patient has attained some age, and an examination through the artificial anus in the left groin shows that the rectal pouch terminates well down in the pelvis, a director or rubber catheter may be introduced through the colotomy-wound and made to enter the rectal pouch and project at the anus if it be present, or at some point of the perineum. This may then be cut down upon, and the gut may be opened and sutured to the skin if possible. Or the method of Demarquay may be adopted, which consists in passing a thread carrying a leaden ball through the artificial anus and out at the anus if it be present, or through the perineum, so as gradually to draw the gut downward.

McLeod<sup>3</sup> has suggested that after the colon has been exposed by laparotomy the perineal incision should be continued so as to open the peritoneal cavity, and that instead of bringing the bowel out at the abdominal wound it should be drawn down and opened and fastened to the edges of the perineal wound.

The operation should be done with full antiseptic precautions, and the wound in the groin dusted with iodoform and dressed with a pad of antiseptic cotton, which should be changed as often as it becomes soiled.

If, for any reason, the surgeon should prefer making the attempt to open the bowel in the loin, the best guide to the position of the colon is a line half an inch posterior to a point midway between the two superior processes of the ileum: the disadvantages of Amussat's operation have been alluded to. If the surgeon fails to find the large intestine, and the distended small intestine shows itself in the wound, it is better to open this and stitch it to the wound rather than to abandon the case and allow the child to perish by intestinal obstruction.

As regards the results obtained by the various operations for the relief of the symptoms due to imperforate rectum, there is no doubt that, in point of safety and as a matter of comfort to the patient, the weight of evidence is largely in favor of the perineal operation.

Cripps<sup>4</sup> has collected one hundred cases of the various operations for the relief of imperforate rectum: his table, although exhibiting a high rate of mortality (fifty per cent.), shows that the largest number of recoveries followed the perineal operation, and that next in number were those cases in which the colon was opened in the groin.

The number of well-attested cases collected by Cripps, Holmes, and other surgeons, in which children with an imperforate rectum have been

<sup>1</sup> Kelsey, *loc. cit.*, p. 45.

<sup>2</sup> Berlin. Klin. Wochenschr., 1879, Nos. 34 and 35.

<sup>3</sup> British Medical Journal, 1880, vol. ii. p. 657.

<sup>4</sup> *Loc. cit.*, p. 38.

operated upon successfully and have lived for years afterwards in comfort, shows that the operation for the establishment of an artificial anus, either in the perineum or in the groin, does not relegate the patient, if he survives, to a life of misery, and cannot, I think, fail to convince even the most conservative surgeon of the humanity and utility of operative interference in such cases.

IV. THE ANUS IS NORMAL IN APPEARANCE, BUT ENDS IN A CUL-DE-SAC, AND THE RECTUM ENDS IN A BLIND POUCH AT A VARIABLE DISTANCE ABOVE THIS POINT.

In this form of malformation the anus and the rectum may be separated by a membranous partition of greater or less thickness (Fig. 4), or a portion of the bowel may be impervious (Fig. 5), or there may be multiple obstructions, or the anal portion may communicate with the vagina in the female (Fig. 6) and the rectum end in a cul-de-sac, as in the celebrated case of Amussat, in which the anus was well formed and communicated with the vagina while the rectum ended in a cul-de-sac (Fig. 5): the cases

FIG. 4.

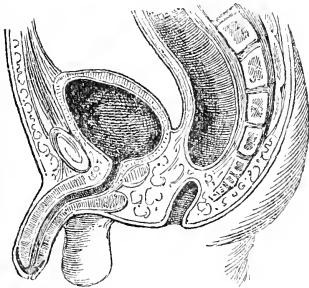

The anus is normal in appearance, but ends in a cul-de-sac, and the rectum ends in a blind pouch at a variable distance above this point. (After Mollière.)

FIG. 5.



A portion of the rectum which terminated in an impervious cord, the anus being normal, removed from a child who died two days after birth.

also in which the anus ended in a sinus passing in front of the prostate gland and the rectum terminated in a closed pouch should be mentioned in this connection. The case of Amussat's is of interest, as it was the one in which he first brought down the rectum and stitched it to the skin, introducing a procedure which is now very generally adopted.

The first variety of this malformation, where the anus is normal but is separated from the rectum by a membranous partition of greater or less thickness, is not an uncommon form. I have myself seen a number of such cases, and through the kindness of Dr. H. F. Formad I had recently an opportunity to examine a child presenting this malformation who died

three days after birth, apparently from peritonitis resulting from a rupture of the transverse colon (Fig. 7).

**Symptoms.**—The symptoms presented in cases of this nature are in no wise different from those presented in any case of complete occlusion.

**Diagnosis.**—The diagno-

FIG. 6.

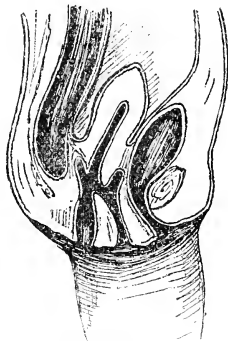

Rectum ending in a cul-de-sac, anal portion opening into the vagina. (After Amussat.)

FIG. 7.

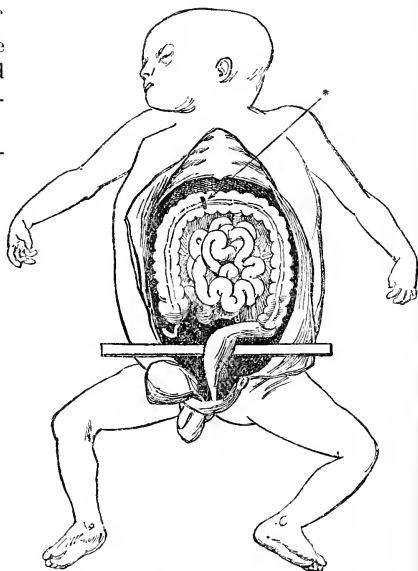

Dissection of a child in whom the fourth variety of this malformation existed, who died of peritonitis resulting from rupture of the transverse colon three days after birth. \* Point at which the rupture occurred.

sis of the nature of the occlusion in cases of this variety of malformation is not often made early, as inspection of the part shows the anus to be normal, and it is only when the nurse or mother notices that the child passes no fecal matter and that it suffers pain, and when the belly becomes swollen or vomiting begins, that the surgeon's attention is directed to the case. An examination of the anus with the finger or a probe will then reveal the nature of the trouble.

**Prognosis.**—From the fact that the nature of the malformation is not often, in these cases, diagnosed until grave symptoms have made their appearance, the prognosis is usually most unfavorable.

**Treatment.**—In this variety of malformation an attempt should first be made to reach the rectal pouch by an incision through the anus back towards the coccyx, and if the gut be found it should be brought down and sutured to the edges of the anal wound. This is a much safer procedure than puncture through the anus, which the surgeon might feel tempted to employ if the partition between the two cavities did not seem to be very thick. If a careful and safe dissection in the perineal region fails to reveal

the presence of the rectal pouch, the surgeon should abandon this operation and should attempt to reach the gut by an incision in the left groin.

V. THE ANUS IS ABSENT, AND THE RECTUM ENDS BY A FISTULA AT ANY POINT OF THE PERINEUM OR SACRAL REGION.

The rectum in this variety of malformation may open, as stated, at some portion of the perineum or sacral region, or it may terminate in a narrow channel under the raphé of the perineum and open at the prepuce (Fig. 8) or at the symphysis pubis, or may terminate in several fistulae at different points.

**Diagnosis.**—The diagnosis of this variety of malformation is generally not difficult, as the absence of the anus and the presence of a fistula through which faecal matter is discharged will clearly point to the nature of the trouble, and a probe introduced into the fistula will often give the surgeon some information as to the position of the rectal pouch.

**Prognosis.**—In these cases the prognosis is more favorable than in those in which complete occlusion exists, for such cases may have satisfactory evacuations through the fistula for some time, and may even live for months or years without suffering any inconvenience from the deformity.

**Treatment.**—If the passage of faeces through the fistula is not sufficiently free and the child begins to show evidence of discomfort, the fistula should first be dilated or carefully increased in size by incision, and if this gives relief from the symptoms presented it should be dilated daily, and no further operation should be attempted as long as the child remains in comfort, or until it has attained an age when a more radical operation may be undertaken with a fair prospect of success. If this does not give relief, or the child has attained a sufficient age, the fistula may be explored with a probe or director, and the position of the rectum ascertained if possible. Having ascertained this, a perineal opening should be made to reach the rectum, and, if this can be accomplished, the bowel should be opened and its edges brought down and sutured to the skin. An attempt may be made to close the fistulous tract at this time (or it may be postponed until a later occasion) by the use of the actual cautery or by laying it open and allowing it to heal by granulation if it be subcutaneous.

FIG. 8.

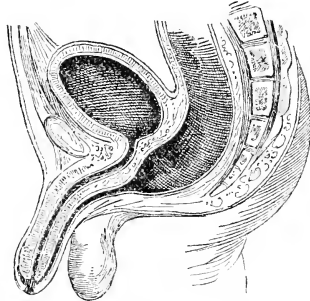

The anus is absent, and the rectum terminates in a narrow canal opening at the prepuce. (After Mollière.)

VI. THE ANUS IS ABSENT, AND THE RECTUM ENDS IN THE VAGINA, BLADDER, OR URETHRA.

These varieties of malformation, according to the point of termination of the rectum, are classified as *atresia ani vaginalis*, *atresia ani vesicalis*,

and *atresia ani urethralis*. Their frequency is remarkable, for in Leichtenstern's statistics<sup>1</sup> forty per cent. of all malformations were of this nature, and Bodenhamer's statistics also show their great preponderance as compared with other forms. This marked tendency of the rectum to terminate in the genito-urinary tract is remarkable when we consider the very definite separation which exists between the rectum and the anterior perineum in the adult: it is attributed by Ball to the method of development of the proctodæum, or a tendency to reversion to the cloacal type of the birds and lower mammals.

**ATRESIA ANI VAGINALIS.**—In that form of malformation in which the rectum terminates in the posterior wall of the vagina, which is the most common form, there may be a small opening allowing an insufficient escape of fecal matter, or there may be a large aperture permitting of a free escape of the contents of the bowel (Fig. 9). The opening may be situated immediately within the fourchette at the entrance of the vagina, or may be located high up in the canal. The symptoms of this malformation depend largely upon the size of the rectal opening.

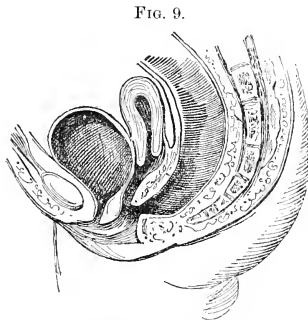

FIG. 9.  
The anus is absent, and the rectum terminates in the posterior wall of the vagina.

**Diagnosis.**—The diagnosis of the case can easily be made by noting that the anus is absent, and that there is an escape of fecal matter from the vagina.

**Prognosis.**—The prognosis in this variety of malformation is favorable, and, if the opening into the vagina is sufficiently large, the child may experience no discomfort. Numerous cases are on record in which patients suffering from this deformity have grown up, have married, and have borne children.

**Treatment.**—If, as often happens, the patient suffers no inconvenience from this malformation, any operation looking towards its cure may be postponed until the patient has attained some age, when the greater development of the parts will conduce to a favorable result. With this end in view, the surgeon may, in cases in which the opening is not sufficiently free, first attempt to overcome this complication by dilatation or enlargement by a careful incision of the fistulous opening.

Should a more radical operation be decided upon, the one which I have seen followed by the best results is performed in the following manner. A director is first introduced into the vaginal opening, and is pushed backward, its point being made to project as much as possible near the normal position of the anus; this is then cut down upon from the perineum, and

<sup>1</sup> Ziemssen's Cyclopaedia, vol. vii. p. 485.

when the rectum is exposed it is incised. The rectal wound being then enlarged to a sufficient extent, the gut is dissected loose, and the edges are brought down and secured to the skin by sutures; by this dissection of the rectum and bringing down of its edges the opening into the vagina is often obliterated if it be a low one. Care should be taken to secure close approximation of the gut to the skin, and to provide for drainage by the introduction of a drainage-tube. The after-treatment of the case consists in keeping the wound dressed with a pad of cotton saturated with some antiseptic solution, and in seeing that the artificial anus is kept properly dilated so as to prevent contraction.

If the opening into the vagina is situated high up, and has not been obliterated by the operation, at a later period, when the parts have increased in size, an operation may be undertaken to close the recto-vaginal fistula, with a good chance of success.

An operation devised by Rizzoli<sup>1</sup> for the relief of this malformation, which retains the outlet that nature has provided, is performed as follows. An incision is carried from the lower margin of the vaginal anus backward through the perineum towards the coccyx, care being taken not to open the intestine. The termination of the rectum, with its vaginal orifice, is now carefully dissected out, and the abnormal anus is transplanted to its natural situation and secured in that position by a few sutures, after which the perineal and vaginal wounds are brought together by deep sutures.

It has been suggested that an incision be made backward from the vaginal opening, including the tissues of the perineum, and opening the rectum, and that a tube be then introduced and held in place by sutures or tapes, the wound thus made being allowed to heal by granulation; but I think either of the operations recommended above will be found more satisfactory.

The operations for the relief of this variety of rectal malformation are, I think, the most satisfactory in their results of all those that have been devised for the cure of congenital malformations of the rectum.

**ATRESIA ANI VESICALIS.**—In that form of malformation which is known as atresia ani vesicalis the rectum communicates with the bladder, either by a narrow orifice near the base of the organ, or by an opening near its fundus (Fig. 10).

**Symptoms.**—The most marked symptom of this form of malformation

FIG. 10.

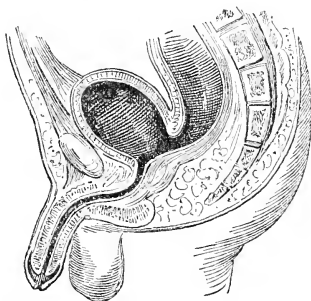

The anus is absent, and the rectum terminates in the bladder. (After Mollière.)

<sup>1</sup> Gross, System of Surgery, vol. ii. p. 605.

is the passage of fecal matter with the urine, accompanied generally, in consequence of the insufficient passage of fecal matter, with pain and straining, and swelling of the belly.

**Diagnosis.**—This is generally made without much difficulty, as there is absence of the anus, and symptoms of occlusion of the rectum generally exist to a greater or less degree, and a small quantity of feces intimately mixed with the urine escapes during urination and not at other times, showing that the opening is into the bladder and not into the urethra.

**Prognosis.**—In this variety of malformation the prognosis is not favorable, from the fact that the bladder in the infant is situated so high up in the pelvis that it is really an abdominal organ, and hence there must be a high termination of the rectal pouch.

**Treatment.**—In the treatment of this very serious form of malformation several difficult operations have been recommended and practised. Martin<sup>1</sup> suggests the introduction of a staff through the urethra into the bladder, and an incision of the neck of the bladder as in lithotomy, which should continue into the rectum. This operation relieves the immediate symptoms of obstruction, but leaves the patient with a urinary and fecal fistula, which would have a great tendency to contract and would be followed by a return of the symptoms of obstruction.

I had the opportunity, a few years ago, of assisting Prof. Ashhurst in performing this operation upon a child a few days old who had been brought to the University Hospital suffering from symptoms of obstruction due to this malformation. In this case the operation was accomplished without much difficulty, and the result was most satisfactory as regarded the comfort of the child while under our observation for a period of two or three weeks; but, unfortunately, the case after this time passed out of observation, and I was unable to ascertain the ultimate result of the procedure.

Ball<sup>2</sup> suggests a laparo-colotomy, and, when the colon has been found, its complete division, with closure of the lower portion and the bringing out of the upper end of the colon at the wound and securing it in that position to establish an artificial anus. This latter operation, although attended with greater immediate risk than the one before mentioned, has the advantage of leaving the patient with control over his urinary secretion.

**ATRESIA ANI URETHRALIS.**—In that form of malformation known as atresia ani urethralis the rectum communicates with some portion of the urethra, allowing the escape of a small amount of fecal matter, which passes more or less in the intervals between urination (Fig. 11).

**Diagnosis.**—This condition may be suspected from the fact that the feces escape during the intervals between urination, and, although the urine may contain fecal matter, it is not intimately mixed with it, as is the case when the rectum communicates directly with the bladder; also it passes

<sup>1</sup> Dictionnaire des Sciences médicales, tome xxiv.

<sup>2</sup> Loc. cit., p. 41.



during the early part of urination, the urine at the latter part of the act being perfectly clear.

**Prognosis.**—In cases of this nature the prognosis is, as a rule, unfavorable, as the rectal opening into the urethra is usually so small that the feces cannot escape in sufficient quantity, and symptoms of intestinal obstruction are rapidly developed. But that it is possible for a child suffering from this malformation to live for some time in comfort is shown by a case recently reported by Mr. Page,<sup>1</sup> in which a man fifty-four years of age, with an imperforate anus, who passed his feces through a fistulous opening in the urethra in front of the scrotum, was admitted to the hospital with symptoms of obstruction of the bowels, dependent upon occlusion of this opening by inspissated feces. The opening was enlarged, and, his symptoms being relieved, he left the hospital, refusing to submit to further operative treatment.

In this case the patient was born with an imperforate anus and a communication between the rectum and the urethra, and, an attempt to make an anal opening having proved unsuccessful, he passed his feces by the urethra until he was ten years of age, at which time the urethra became occluded by inspissated feces, and an opening was then made in front of the scrotum, through which he continued to have satisfactory evacuations until he was admitted to the hospital.

**Treatment.**—The treatment of this form of malformation consists in finding the rectum by means of a perineal incision; and, as the gut is low down, this is generally accomplished without difficulty. The details of the operation are similar to those before mentioned, and need not be repeated. F. J. Sheppard<sup>2</sup> reports a case of this nature, in which he reached the rectum by perineal incision, and brought it down and sutured it to the edges of the wound, with a satisfactory result. Dr. Cabot<sup>3</sup> reports a similar case, in a child five weeks of age, in which he operated, with an equally satisfactory result.

In this connection it is interesting to note a case mentioned by Ball, in which a diverticulum from the rectum passed forward and was intimately associated with the urethra but did not communicate with it, which was successfully operated upon in after-life.

FIG. 11.

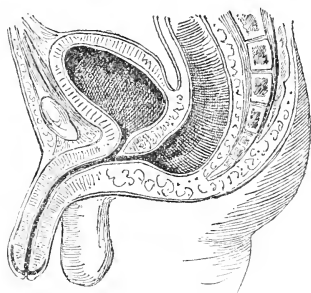

The anus is absent, and the rectum terminates in the urethra.

<sup>1</sup> British Medical Journal, October 20, 1888, p. 875.

<sup>2</sup> Edinburgh Medical Journal, 1884, p. 118.

<sup>3</sup> Medical News, November 10, 1888, p. 526.

VII. THE ANUS AND RECTUM ARE NORMAL, BUT THE URETERS, VAGINA, OR UTERUS OPEN INTO THE RECTAL CAVITY.

This is a rare form of malformation, but it is not one that is incompatible with life. Bodenhamer has collected a number of cases in which the ureters opened into the rectum, the bladder being absent.

As this is a malformation in which occlusion of the bowels does not exist, and as life is not endangered by its presence, no immediate operation is called for.

In that form in which the vagina or uterus opens into the rectum, when the child has attained some age and the parts are well developed, an operation to close the fistula and replace the organs in their normal position may be attempted with a fair prospect of success. In cases in which the ureters open into the rectum no operative interference could be of any avail.

VIII. THE RECTUM IS TOTALLY ABSENT.

This form of rectal malformation differs from the third variety of malformation only in the amount of the rectum which is wanting, and its existence may be suspected in those cases in which an exploration of the pelvis by perineal incision fails to reveal the presence of the rectal pouch.

The treatment of this condition is by laparo-colotomy, preferably in the left groin, and the formation of an artificial anus.

IX. THE LARGE INTESTINE IS TOTALLY ABSENT.

When this condition exists it is often associated with a fecal fistula at the umbilicus or some other portion of the body, and, aside from the securing of free exit of feces from this fistula, either by dilatation or by careful incision, is, unfortunately, beyond the reach of surgical aid.

Cases of this nature have already been described under the head of abnormalities of the large intestine.

---

## DISEASES OF THE ANUS.

### PRURITUS ANI.

Pruritus ani is an affection which is occasionally seen in childhood, and is characterized by a painful itching of the anal region, which causes the child constantly to scratch the part, the skin in the vicinity of the anus becoming thickened, eczematous, and moist from exudation as a result of the irritation thus produced.

Pruritus ani may result from various causes,—for instance, from eczema of the anus or from the presence of oxyuris vermicularis in the rectum, from pediculi or scabies, or from the presence of a vegetable parasite, as is the case when the itching is due to the affection known as eczema marginatum.

Dr. Hare<sup>1</sup> has recently reported a case of that rare affection *aspergillus* of the anus, occurring in a boy four years of age. In certain other cases, in which its presence is not to be attributed to any of the above-named causes, it can be traced to improper diet or chronic constipation. The latter condition is not uncommon in infants, and is due, as was pointed out by Jacobi, to a number of flexures in the lower part of the colon, in which faeces are arrested, giving rise to an obstinate form of constipation.

**Treatment.**—Where the condition can be traced to the presence of eczema, the parts should be frequently bathed with hot water and washed carefully with green soap, and, if this does not effect a cure, one of the following lotions may be used :

R Acidi carbolici, ℥xxx;  
Liq. calcis, fʒvi.  
Misc.

R Acidi carbolici, fʒi;  
Glycerini, fʒi;  
Aquæ, q. s. ad fʒvi.  
Misc.

Or the following ointment may be employed :

R Ungt. picis, ʒi;  
Ungt. zinci ox., ʒiii;  
Ungt. aq. roseæ, ʒiv.  
Misc.

When the itching can be traced to the presence of parasites, either animal or vegetable, the use of some of the antiparasitic lotions or ointments appropriate for the individual case will rapidly relieve the condition. In cases in which the affection is dependent upon errors in diet, a change of diet will often be followed by a satisfactory result. Where the trouble arises from chronic constipation, the diet should be changed, and enemata or suppositories of glycerin should be employed in preference to purgative medicines.

#### SYPHILITIC AFFECTIONS OF THE ANUS.

*Mucous Patches, Moist Papules, Condylomata.*—Mucous patches and moist papules are affections which occur with comparative frequency in the region of the anus as the result of congenital syphilis. Allingham speaks of numerous tracks or fissures of the mucous membrane of the anus in children suffering from hereditary syphilis. Condylomatous growths may appear upon these syphilitic lesions, which are acuminate and spring from previously-existing papules or mucous patches, and are accompanied by a very fetid discharge of a characteristic odor: these growths are to be distinguished from the simple form of vegetations which frequently

<sup>1</sup> University Medical Magazine, June, 1889, p. 525.

occur in this region in children and which are in no way dependent upon the presence of inherited syphilis.

The appearance of these lesions is so characteristic that the diagnosis is not difficult.

**Treatment.**—The treatment of these syphilitic lesions of the anus should be both constitutional and local. The constitutional effects of mercury can best be obtained in young children by the use of a binder spread with mercurial ointment applied around the abdomen. The local treatment of the anal lesions should consist in the application to them of the solid stick of nitrate of silver, or of the acid nitrate of mercury, or in dusting them with a powder composed of equal parts of calomel and oxide of zinc. Under this treatment they will generally rapidly disappear.

#### VEGETATIONS OR WARTS OF THE ANUS.

Vegetations of the anus are often seen in children, and the masses may attain great size (Fig. 12). They are papillary overgrowths similar in structure to warts situated in other parts of the body, and are covered with a squamous epithelium. From their situation, they are apt to become moist, and as a result of this condition there is often present a certain amount of offensive discharge.

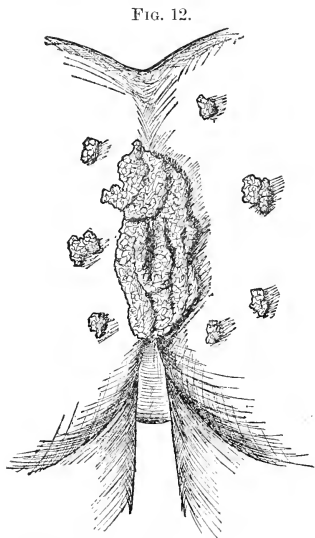

Vegetations around the anus: from a patient in the Children's Hospital.

**Treatment.**—In the treatment of these growths, if the parts can be kept perfectly dry a cure may rapidly result, and, with this end in view, if the growths are not very large, dusting the parts with lycopodium and powdered oxide of zinc will often be followed by their rapid removal.

They may also be touched with the solid stick of nitrate of silver or with a saturated solution of chromic acid. If the masses are large they may be destroyed by the application of the actual cautery, or they may be trimmed away with scissors: the objection to the latter means of removing them is the profuse hemorrhage which may result, but this can generally be controlled by the application of a firm compress to the bleeding surface.

#### FISTULA IN ANO.

Fistula in ano is an affection in which there is an abnormal communication between the mucous surface of the rectum or anus and the skin in

its immediate neighborhood, and when the above conditions exist it constitutes what is known as a complete fistula. When the fistulous tract has only one aperture, either mucous or cutaneous, it is termed an incomplete fistula.

This affection is certainly very rare in infants and children, but does occur with sufficient frequency in this class of patients to render its diagnosis and treatment most important. Allingham mentions the fact of its occurrence in children of a very tender age; and I have seen a number of such cases at the Children's Hospital and call to mind a case of complete fistula in a child a few months old.

The condition may result from wounds involving the anus or rectum, from perforating ulceration of the mucous membrane of the rectum, and probably with greater frequency from ischio-rectal abscess opening into the rectum or through the skin in the vicinity of the anus. The causes of ischio-rectal abscess are in many cases difficult to make out, but I think it may be due to a phlebitis or periphlebitis of the hemorrhoidal veins resulting in suppuration.

**Diagnosis.**—The diagnosis of this affection is generally rendered sufficiently simple by the introduction of the finger into the rectum and a probe into the external opening, when by a little careful manipulation the latter may be made to enter the bowel if the fistula be a complete one. In incomplete fistulae which have an opening upon the skin, or in those cases in which the opening is only into the rectum, the diagnosis is not so clearly made out. In the former class of cases, if the finger be introduced into the rectum and a probe be passed into the external opening, it can be felt at some point to come near the wall of the bowel; and in the latter class, if the surgeon palpates the tissues surrounding the anus carefully with the finger, he will often feel an indurated mass of tissue which indicates the position of the internal fistula. The finger introduced into the rectum may also feel the orifice of the internal opening, and the discharge of pus with the stool points to the existence of this affection.

In this connection it should be remembered that in certain cases of disease of the bones of the spine, of the sacrum, or of the pelvis, the purulent matter may find its way to the surface through the connective tissue about the rectum and perforate the skin in the neighborhood of the anus, or it may open into the rectum and escape by the anus. In such cases a careful examination of the patient will often reveal the origin of the pus, and will show that the case is not one of ordinary fistula in ano.

**Treatment.**—The treatment of this affection is similar to that of fistula in adults, consisting in the free division of all the tissues between the internal and the external opening of the fistula, and is accomplished in the following manner. A director having been introduced into the external opening of the fistula, the finger is introduced into the rectum, and when the point of the director is felt it is brought out of the anus. The superimposed tissues are then divided with a bistoury. The track of the fistula

should next be carefully explored, to ascertain if there be any branching sinuses running off from it, and if such be found they should be freely laid open. The track of the fistula should now be touched with a solid stick of nitrate of silver and packed with iodoform gauze or lint saturated with carbolized oil, after which it is to be allowed to heal by granulation, the dressing being changed at intervals of a few days and the bowels being kept quiet for three or four days by the administration of a small quantity of opium.

In cases of incomplete external fistula the director should be introduced into the external opening, and, guided by the finger in the rectum, should be made to perforate the wall of the bowel at the point where it comes in close contact with it: the subsequent steps of the operation should be the same as those previously detailed.

In that variety of incomplete fistula in which there is only an internal opening, where the position of the fistula can be located by the presence of induration at some point about the anus, an incision having been made through the skin at this point, a director is introduced and made to enter the rectum, and its end is then brought out of the anus, the subsequent treatment of the case differing in no wise from that of complete fistula.

If it is found in any case of fistula that the internal communication is very high up in the rectum, and its division by the knife is considered unsafe by reason of the hemorrhage which might result, an elastic ligature may be introduced by means of an eyed probe and brought out at the anus, after which the ligature is tied and allowed to cut its way out, and the wound resulting is treated like that resulting from the division of the tissues by the knife.

#### FISSURE OF THE ANUS.

Fissure of the anus is an affection in which there exists in the mucous membrane of the anus a small linear ulcer, which is productive of great pain after the bowels have been moved.

This affection is much less frequent in children than in adults, but I feel sure that a careful inspection of the anal region of children who complain of pain at or after stool would show that its presence is not so unusual as is generally supposed. I have seen several cases of this affection in young children, and both Allingham and Curling mention cases which they have met with in quite young children.

Jacobi<sup>1</sup> thinks fissure of the anus a much more common affection in children than is generally supposed, and believes that many of the fretful children who sleep badly and cry constantly, and often present symptoms simulating those of vesical calculus, suffer from fissure of the anus. He quotes Kjellberg, who, at the Dispensary at Stockholm, among nine thousand and ninety-eight children found one hundred and twenty-eight cases of fissure of the anus; of the patients suffering from this affection sixty were

---

<sup>1</sup> Intestinal Diseases of Children, p. 295.

boys and sixty-eight were girls, the majority were less than one year of age, and in seventy-three cases the patients were less than four months old.

**Diagnosis.**—The diagnosis of this affection is made from the pain which is experienced during or after stool, and from a careful inspection of the anus; the stool, also, may contain a few drops of blood, which would direct the surgeon's attention to the possibility of the existence of this affection; the rectum should at the same time be examined with the finger for the presence of polypus, which frequently coexists with fissure of the anus.

**Treatment.**—In children suffering with fissure of the anus the treatment required to effect its cure is less heroic than that so frequently required in adults suffering from the same affection,—namely, division or stretching of the sphincter.

These cases in the former class of patients can generally be successfully treated by the application of a twenty-grain solution of nitrate of silver to the ulcer, or by lightly touching its surface with the solid stick of nitrate of silver, and afterwards keeping the part well smeared with an ointment composed of thirty grains of iodoform to the ounce of vaseline, the bowels being kept in a soluble condition.

#### STRICTURE OF THE ANUS.

Stricture of the anus may be congenital, or may result from the contraction following wounds of this region, either accidental or resulting from operations in the vicinity of the anus.

The treatment of this condition resulting from congenital malformations has been already discussed. For cases of stricture of the anus arising from other causes the treatment is very similar, consisting largely in gradual dilatation of the contracted orifice, either instrumental or digital: if this fails to relieve the condition, a careful incision of the contracted parts should be practised, and subsequent dilatation employed for some time.

#### DIPHThERIA OF THE ANUS.

This affection is occasionally seen in patients suffering from diphtheria of the pharynx and larynx. It usually occurs late in the disease, and only in cases in which the disease has profoundly impressed the system. In such cases the deposit of diphtheritic membrane may involve the anus and extend on to the buttocks, and to the vulva in female children.

The prognosis of this affection is extremely unfavorable. The few cases which have come under my personal observation have all terminated fatally, in spite of treatment. The treatment of this affection consists in the employment of such constitutional remedies as the surgeon considers appropriate. The local manifestation of the disease in the anal region may be dressed with iodoform or with a solution of the bichloride of mercury, one in two thousand to one in four thousand.

## DISEASES OF THE RECTUM.

## PROCTITIS.

Proctitis, or inflammation of the rectum, is not an infrequent affection in childhood, and may result from injury received from without, or from injury to the mucous membrane from the feces or from materials contained in the feces. It exists in two forms,—acute catarrhal proctitis and chronic catarrhal proctitis.

**ACUTE CATARRHAL PROCTITIS.**—This is an affection in which the inflammatory symptoms are limited to the rectum. It is characterized by great tenesmus and the frequent passage of bloody mucus, at first mixed with feces. Vesical irritation and œdema of the mucous membrane of the anus and lower portion of the rectum are generally present, and, as the result of this condition and of the constant straining, there is often observed a partial prolapse of the rectum.

**Diagnosis.**—Patients suffering from acute catarrhal proctitis present many symptoms in common with those of dysentery, but the abdominal pain and the constitutional symptoms of the latter affection are generally wanting.

**Treatment.**—A child suffering from this affection should be kept in the recumbent posture, and the bowels should be evacuated by the administration of a small dose of castor oil or of one of the saline cathartics, either the sulphate of sodium or of magnesium or some of the natural mineral waters. The diet should be restricted to milk, animal broths, or eggs.

If the tenesmus continue after the bowels have moved, a few drops of tincture of opium with starch-water should be injected into the rectum, or a rectal suppository containing

R Pulv. opii, gr.  $\frac{1}{2}$ ;  
Ext. belladonnæ, gr.  $\frac{1}{2}$ ;  
Iodoformi, gr. i;  
Ol. theobromæ, q. s.,

may be employed; and if the patient shows signs of exhaustion, stimulants should be carefully administered.

The disease generally runs a short course, and under treatment the symptoms generally subside in a few days.

**CHRONIC CATARRHAL PROCTITIS.**—This affection usually results from acute catarrhal proctitis. It is characterized by the discharge of mucus mixed with feces, and by the absence of pain and tenesmus: in some cases, in which ulceration of the mucous membrane of the rectum exists, there may be in addition the discharge of a small quantity of blood and purulent matter with the mucus.

**Treatment.**—In the treatment of this disease the same precautions as regards diet should be observed as in cases of acute proctitis, and the bowels



should be moved by the administration of a saline cathartic if the evacuations are not sufficiently free. The local treatment should consist in the use of suppositories of iodoform or the use of an enema of nitrate of silver, gr.  $\frac{1}{4}$  to gr. i to water fʒi, which can be gradually increased in strength if it does not cause pain.

#### PERIPROCTITIS.

Periproctitis is an inflammation of the connective tissue surrounding the rectum, which may be the result of septic causes or direct injury, or may arise from the introduction of foreign matter through ulceration or perforation of the rectum. It may terminate in abscess or gangrene of the cellular tissue, with subsequent implication of the skin. Erysipelas may also attack this region, giving rise to erysipelatous periproctitis.

**Treatment.**—In this affection prompt treatment is required, and, as soon as the swelling and induration can be made out, free incision should be made through the skin into the cellular tissue in lines radiating from the anus. The wounds thus produced should be washed with a solution of bichloride of mercury, one in two thousand to one in four thousand, or with a solution of chloride of zinc, fifteen grains to the ounce of water, and should be dusted with iodoform and covered with a bichloride gauze or cotton dressing. If the parts have become gangrenous, the incisions should be carried into the living tissue and a charcoal poultice applied. The patient should be given a liberal diet, with alcohol and tonics.

#### ISCHIO-RECTAL ABSCESS.

Ischio-rectal abscess consists of a purulent collection in the loose cellular tissue surrounding the rectum, and is a most painful and serious affection: the part it plays in the causation of fistula in ano has been mentioned under that heading. This affection may result from injuries of the rectum either from within or from without, from phlebitis or periphlebitis of the hemorrhoidal veins, or from the escape of fecal matter into the surrounding cellular tissue through perforating ulceration of the rectum.

**Symptoms.**—The symptoms of ischio-rectal abscess are throbbing pain and a sense of fulness in the lower portion of the rectum, the pain being measurably increased at the time the bowels are moved.

**Diagnosis.**—The diagnosis is made by a careful examination of the rectum with the finger, by which means the rectal wall may be found to bulge at a certain part, and there may also be observed swelling and œdema of the skin near the anus: palpation of this region will often reveal the presence of fluctuation.

**Treatment.**—The treatment of ischio-rectal abscess consists in early and free incision. It is generally conceded that there is no form of abscess which demands more prompt and free opening, for by this means the pain is quickly relieved and the danger of the formation of a fistula in ano is almost certainly avoided.

In opening these abscesses I think the practice of Allingham should be followed,—that is, to etherize the patient and place him in the lithotomy position. The cavity of the abscess should then be freely laid open by an incision through the skin, and the finger introduced into the wound to break down any secondary cavities or loculi: if it is found that there has been much burrowing of the pus, incisions should be made at right angles to the original incision so as to lay all cavities freely open. The cavity of the abscess is then to be washed out with a solution of bichloride of mercury, one in two thousand or one in four thousand, or with a solution of carbolic acid, one in forty. The wound is next to be carefully packed with lint saturated with carbolized oil, one in thirty, or with iodoform or bichloride gauze. An external dressing of gauze is finally to be applied to the wound and held in place by a T-bandage. The packing need not be disturbed until it becomes loose or soiled, and it then should be renewed in the same manner, the wound being allowed to heal by granulation. The bowels should be kept quiet for four or five days, and then should be moved by a gentle laxative. Under this method of treatment the cavity of the abscess is rapidly filled up, and a cure results without the formation of a fistula.

#### MARGINAL ABSCESS.

Marginal abscess, which consists of a circumscribed suppuration starting in the mucous follicles or from a fissure of the anal margin, is, I think, much more common in childhood than ischio-rectal abscess, and is a much less serious affection. This affection, although painful, is not a serious one, and it does not result in the formation of a fistula in ano.

**Treatment.**—The treatment of marginal abscess consists in making a free opening with a bistoury, in doing which the tip of the finger should be passed into the rectum to steady the abscess-cavity and make it more prominent before it is incised: the wound should then be dressed with lint saturated with carbolized oil. Prompt healing usually results.

#### ULCERATION OF THE RECTUM.

Ulceration of the rectum, aside from those cases in which it exists as a result of chronic dysentery or of chronic catarrhal proctitis, is not a common affection in childhood.

The treatment of this affection consists in the restriction of the diet and the regulation of the bowels, and in the local use of suppositories of iodoform or of injections of a solution of nitrate of silver, gr.  $\frac{1}{4}$  to gr. i to water ℥i.

#### STRICTURE OF THE RECTUM.

Stricture of the rectum may result from congenital malformation of the rectum such as has been previously described, from the presence of growths, or from the contraction following wounds of the organ, the result either of accident or of operation. Bodenhamer mentions inherited syphilis as an occasional cause of congenital stricture of the rectum.

**Treatment.**—The treatment of this affection should consist in the gradual dilatation of the rectum, either instrumental or digital; if it be due to the presence of growths, their removal should be accomplished if possible; if it be due to syphilis, the treatment appropriate for this affection is indicated.

#### SYPHILIS OF THE RECTUM.

Lesions of the rectum due to inherited syphilis are certainly much less frequently met with in children than similar affections of the anus.

Ball<sup>1</sup> has described a case of gummatous infiltration of the coats of the rectum in a child ten years of age who at the same time exhibited well-marked symptoms of inherited syphilis, and the close resemblance of this case to the disease of the rectum described by Fournier resulting from the later stages of the acquired disease is pointed out. Oser, of Cracow,<sup>2</sup> has described two cases of gummatous infiltration of the intestines in children suffering from congenital syphilis.

**Treatment.**—The treatment of syphilitic lesions of the rectum presents no peculiar features, consisting in the administration of mercury or the iodide of potassium in the same manner as in the treatment of corresponding lesions in other parts of the body.

#### PROLAPSUS OF THE RECTUM.

Prolapsus of the rectum is that condition in which there is a protrusion of a portion of the rectum through the anus. It is recognized as presenting itself in three varieties:

1. The mucous membrane of the rectum above protrudes from the anus (partial prolapsus).
2. The entire thickness of the walls of the rectum is included in the prolapsus (complete prolapsus).
3. There exists an invagination as well as a prolapsus of the rectum.

Prolapsus of the rectum in some one of its varieties is a very common affection in childhood, and the frequency of its occurrence may be accounted for both on anatomical and on pathological grounds.

The looseness of the attachment of the submucous connective tissue to the walls of the rectum is a well-recognized anatomical fact, and probably plays an important part in the production of prolapsus of the rectum: this was clearly demonstrated by the experiment of Mollière,<sup>3</sup> in which inflation of the submucous tissue of the rectum in the dead subject produced protrusion of the mucous membrane through the anus. The straightness of the coccyx in children is said to favor the production of prolapsus of the rectum.

The great amount of straining which seems to be necessary to bring

<sup>1</sup> Loc. cit., p. 184.

<sup>2</sup> Hereditary Syphilis, Diday and Sturgis, p. 90.

<sup>3</sup> Maladies du Rectum, p. 199.

about a satisfactory remission of fever in infants and young children is a factor in the production of this affection, this has been explained by Jacoby by the anatomical fact that in children it is not uncommon to find the intestine enlarged and fixed in the lower part of the abdomen.

The habit of commencing with nursing and weaning of placing the child upon the mother's breast and allowing it to spend a large portion of time in this position, with a view to keeping him quiet and out of mischief is even the production of this affection, and is a custom which cannot be too well established.

The violent swelling due to the presence of a polypus in the rectum, so near to the external opening, is not a common occurrence, is frequently a mark of the production of polypus of the bowel. Improper diet or the custom of allowing the child to eat at all times during the day, and at a regular interval, oversteering the measure of a large number of passages per diem, is the cause of this affection. That improper diet and overfeeding are causes of polypus of the rectum is very clearly impressed on my mind by the fact that at the Children's Hospital it is not an unusual occurrence to have it when attended to, the parents are ignorant of the theory that they have overfed the child at the same time with passages of the rectum. In these cases, it is not cured until the regulated diet of the house is often happens that the rectum only is found to be enlarged, before, up and after a few weeks' rest on the breast a cure is effected. This observation is confirmed by so high an authority as Mr. Holmes.

**Symptoms.**—The most marked symptom of this affection is the presence of a red, fleshy mass protruding with mucous membrane during stool, as is depicted in the engravings. It is usually accompanied by pain, but usually induces spontaneous reduction as well as the remaining effects only.

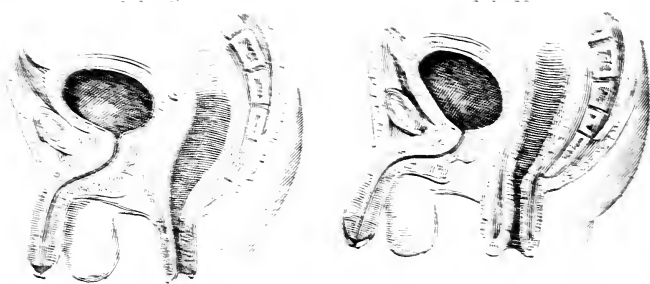

Fig. 1. Polypus of the rectum. Fig. 2. Same, after spontaneous reduction of the polypus. After Holmes.

If the polypus is of the parietal variety little inconvenience is experienced unless the protruded portion of the bowel is allowed to remain out for some time, when it may become enlarged or even ulcerated; and this is

more apt to occur in cases of complete prolapsus. In the latter variety of this affection obstruction of the bowels may exist as the result of the invagination of the prolapsed bowel—gangrene of the protruded mass may occur in some cases and death may result from this complication as well as from perforation.

**Diagnosis.**—The diagnosis of prolapsus of the rectum is not difficult; the affection could be confounded only with hemorrhoids, an extremely rare disease in childhood, or with polypus. An examination of the rectum after the reduction of the mass will, in a case of prolapsus of the rectum, show the presence of no tumor, and the appearance of prolapsus of the rectum is so characteristic (Fig. 11)—the annular fold of tissue around the whole anus with its deepened central notch—man it is not difficult to distinguish it from either of the other affections.



FIG. 11.—Prolapsus of the rectum in the female.

The greatest difficulty in diagnosis is likely to arise in cases of acute intussusception of children, in which the intussusception may protrude from the rectum and closely resemble in appearance a case of prolapsus of the rectum; that this is possible is proved by the fact that such cases in a post-operative age, under the impression that they were cases of prolapsus of the rectum, the mistake being discovered only at the time of operation. The diagnosis of the latter affection from prolapsus of the rectum is not difficult if the surgeon makes a careful digital examination of the protruded mass, and has under his consideration the previous history of the case, such as sudden pain and changes in the occurrence of more or less obstruction of the bowels and the passage of blood and mucus preceding the appearance of the tumor through the anus.

**Treatment.**—The treatment of the condition when the prolapsus of the rectum actually exists consists in returning the mass as soon as possible; this can generally be accomplished with ease by laying the patient across the knees and making gentle pressure with the fingers over the whole mass of the tumor for a few moments to return the contents of the bowel and the fluids effused in the vessels, the central portion being pushed up first with the finger.

In recent cases little difficulty is experienced, but in long-standing ones, in which inflammation and effusion has taken place, there may be great trouble in returning the bowel, and it may prove necessary to administer an anæsthetic before the reduction can be satisfactorily accomplished.

When the reduction has been accomplished, a compress should be placed over the anus and held in place by a T-bandage, and the patient should be kept in the recumbent posture for a short time.

The preventive treatment of this affection consists in not allowing the child to have the bowels moved in the sitting posture; and prolonged straining on the chamber utensil should be absolutely interdicted. The child should be allowed to have the bowels moved only while in the recumbent posture, on the bed-pan, or on the side, or in the standing posture, and at the same time the nurse or mother should support the perineum and anus by two fingers placed one on either side of the anus, or should forcibly draw the skin of the buttock to one side while the child is passing the stool.

When prolapsus of the rectum depends upon the presence of a vesical calculus, or of a contracted prepuce, or of a rectal polypus, or of parasites, inducing great straining efforts, the removal of the cause will generally promptly effect a cure of this condition. I recently had under my care at the Children's Hospital a little girl three years of age who suffered from prolapsus of the rectum due to the straining induced by the presence of a vesical calculus, and a cure promptly followed the removal of the calculus.

The importance of looking carefully after the child's diet, which, as before mentioned, may be a factor in the production of this affection, should not be overlooked by the physician.

Enemata of cold water, or of astringent solutions, such as decoction of oak bark or solution of alum, or suppositories containing extract of nux vomica and ergot, may be employed. Of these applications I think the cold water enemata will be found the most satisfactory.

I am not aware that submucous or subcutaneous injections of carbolic acid or of ergotine, as recommended by Kelsey<sup>1</sup> or Vidal,<sup>2</sup> for the treatment of this condition in adults, have ever been tried in the treatment of prolapsus of the rectum in children, and I therefore should not recommend their employment. In cases of persistent prolapsus of the rectum in children, where the various palliative measures have failed to be followed by relief of the condition, I think the safest and, in my experience, the surest method of treatment is that recommended by Allingham, which consists in the application of nitric acid to the mucous membrane of the protruded gut.

This method of treatment is as follows. The child's bowels having been previously opened by the administration of a small dose of castor oil or by the use of an enema, the patient is anaesthetized, and the surface of the prolapsed bowel is carefully dried and cleansed of mucus by wiping it with absorbent cotton. The whole surface of the mucous membrane is then to be painted with nitric acid applied with a swab, care being taken not to allow the acid to come in contact with the adjacent skin. A pledget of oiled cotton or lint is now introduced into the central depression of the prolapsed mass, and by pressing it upward with the finger the mass is re-

<sup>1</sup> Loc. cit., p. 115.

<sup>2</sup> Paris Médical, August 28, 1879.

duced. A pad is then placed over the anus, and the buttocks are brought together by broad strips of adhesive plaster. The bowels should be kept quiet for two or three days by the administration of a small amount of opium, and at the end of this time they should be opened by a laxative.

In practice I have found that the introduction of the oiled cotton or lint into the prolapsed bowel at the time of operation is not necessary, as the child is apt to pass it by straining when he recovers from the anæsthetic: hence I generally omit its use, and merely coat the cauterized surface of the bowel with olive oil or vaseline before reducing it, the omission in no way affecting unfavorably the result of the operation.

The prolapsus may recur with the first few passages, but a permanent cure is generally effected by one application of the nitric acid; should this not be the case, the cauterization may be repeated in a few weeks. I have never failed to see, in prolapsus of the rectum in childhood, a second or third application bring about a cure.

The use of the actual cautery, the ligature, or the clamp and cautery has been recommended, but is attended with danger in cases of complete prolapsus of the rectum in which the peritoneum is included in the mass, and, although they have been used with success in the treatment of this affection in adults, I have never seen a case of prolapsus of the rectum in childhood in which their employment seemed to me to be justified, and in which the simpler and safer procedure—namely, cauterization with nitric acid—failed to give a satisfactory result.

In long-standing cases of prolapsus in which invagination has occurred and the patient is suffering from obstruction of the bowels, if the prolapsus cannot be reduced under ether, the only operation which holds out any prospect of success is the establishment of an artificial anus by a laparocolotomy, which should preferably be made in the left groin. In such a case, if the child survive, at a later period attempts may be made to close the fecal fistula in the groin, as soon as the invaginated portion of the gut has been removed by sloughing or other means, thus allowing the feces to escape through their natural channel.

#### HEMORRHOIDS.

Hemorrhoids are vascular tumors occupying the lower portion of the rectum, arising from a dilatation or proliferation of the blood-vessels. They may be either internal or external, and accordingly may be covered by mucous membrane or by skin. This is a very rare affection in childhood: when it does exist, the hemorrhoidal tumors generally consist of dilated veins, and they are apt to occur in children of a weak and delicate constitution. A few cases have been reported: Allingham<sup>1</sup> mentions a case of venous hemorrhoids which came under his observation in a child three years of age; Ball has seen several cases occurring in quite young

<sup>1</sup> Loc. cit., p. 75.

children; F. Ogston<sup>1</sup> reports a case in which the disease appeared to be congenital; and my own experience has been limited to one case occurring in a child five or six years of age.

**Symptoms.**—The symptoms of hemorrhoids in children are very similar to those of the same affection in adults, consisting in the protrusion of the hemorrhoids and occasional bleeding at the time of defecation.

**Diagnosis.**—From the symptoms presented, the physician would possibly be justified in suspecting the presence of prolapsus of the rectum, but the diagnosis can readily be made by a careful local examination.

**Treatment.**—The treatment of hemorrhoids in children consists in the administration of iron and cod-liver oil, the local use of astringent ointments, and regulation of the action of the bowels: under this treatment a cure will generally result. If, on the other hand, the tumors continue to bleed and be protruded at defecation, the surgeon can have recourse to the injection into the hemorrhoids of a twenty-five-per-cent. or fifty-per-cent. solution of carbolic acid in glycerin, or to the use of the ligature or of the clamp and cauterly.

#### POLYPUS OF THE RECTUM.

Polypus of the rectum is not an uncommon disease in childhood. It is usually characterized by the presence of a follicular tumor springing from the mucous membrane of the rectum, to which it is attached by a narrow pedicle at a point an inch or an inch and a half above the anus. The follicular or adenoid polypus is the variety of growth which is most commonly seen in children, and closely resembles in its structure the normal mucous membrane from which it has its origin, although its glands are more abundant and are often more branched and convoluted.

The fibrous polypus, composed chiefly of fibrous cellular tissue, also has been met with, and very rarely cystic polypus; of the latter variety Cripps<sup>2</sup> reports a case occurring in a boy nine years of age. Disseminated polypi of the adenoid variety have also been observed in young persons; Mr. Thomas Smith<sup>3</sup> has recorded three cases of this affection occurring in members of the same family, and Cripps<sup>4</sup> mentions cases of this nature in which considerable areas of both the

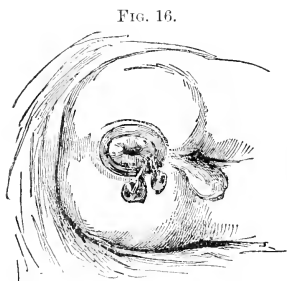

Polypi of the rectum. (After Ball.)

rectum and the colon were studded with these growths.

The tumors may be single or multiple (Fig. 16), and are of a bright-red color when first extruded, but become darker and more venous in ap-

<sup>1</sup> London Lancet, May 12, 1886.

<sup>2</sup> Loc. cit., p. 281.

<sup>3</sup> St. Bartholomew's Hospital Reports, vol. xxiii. p. 225.

<sup>4</sup> Loc. cit., pp. 275, 276.



pearance after they have been protruded some time and their circulation has been interfered with by the constriction of the sphincter: the length of the pedicle may vary from half an inch to two or three inches.

Eustace Smith says that polypus of the rectum is rare in children under ten years of age; Bokai found twenty-five cases of this growth in sixty-five thousand nine hundred and seventy patients. Jacobi<sup>1</sup> says that he sees from one to three cases annually among five hundred children.

**Symptoms.**—The presence of a rectal polypus gives rise to a sense of fulness and distress in the lower part of the rectum, and there may be expulsive efforts with tenesmus. The escape of glairy or bloody mucus or of blood is a very constant symptom, and in children this alone is presumptive evidence of the presence of this growth.

**Diagnosis.**—The diagnosis is not difficult, as the polypus is apt to present at the anus or protrude from it during defecation; it is likely to be confounded only with hemorrhoids or prolapse of the rectum, and a careful examination with the finger will disclose the presence of the pedicle to which the growth is attached. It is well to give an enema just before the examination, and when it passes the growth is apt to be brought to the lower part of the rectum, or may present at the anus. It is also advisable to introduce the finger well into the rectum, and to make the examination of its walls as the finger is withdrawn with a sweeping motion, by which means the pedicle of the polypus may be hooked upon the finger.

It is probable that in many cases polypi undergo a spontaneous cure by the separation of their attachments from the bowel, and are passed with the stool, all symptoms depending upon their presence disappearing upon their expulsion: a number of such cases have been reported.

**Treatment.**—The treatment of polypus of the rectum is simple and satisfactory. The tumor may be seized with the fingers or forceps and twisted off, and the stump touched with the solid stick of nitrate of silver, or with nitric acid: the only disadvantage of this method is the possibility of troublesome hemorrhage.

I think the best and safest method is to seize the polypus and draw it out so as to expose its pedicle, and to encircle this with a ligature close to the mucous membrane, care being taken not to make sufficient traction to invert the wall of the rectum, which might then be included in the grasp of the ligature. The ligature should next be firmly tied, and the tumor removed by dividing the pedicle in advance of the ligature. If a number of polypi exist, the same procedure is repeated for each growth.

#### ANGEIOMA OR NÆVUS OF THE RECTUM.

Nævus of the rectum is an extremely rare affection, and very few cases have been observed. Mr. Arthur E. Barker<sup>2</sup> has published a case of this

<sup>1</sup> Intestinal Diseases of Children, p. 286.

<sup>2</sup> Med.-Chir. Trans., vol. lxvi.

nature, and Mr. Howard Marsh has reported the case of a girl ten years of age who suffered from rectal hemorrhage and in whom an examination revealed a nœvoid growth in the lower part of the rectum.

The principal symptom consequent upon this disease would be hemorrhage, and some difficulty might be experienced in diagnosing it from hemorrhoids.

**Treatment.**—The treatment of angeioma of the rectum consists in the use of a ligature to strangulate the growth, or in the application of nitric acid or of Paquelin's cautery; the latter means was successfully employed in the case reported by Mr. Marsh.

#### MALIGNANT DISEASE OF THE RECTUM.

Malignant disease of the rectum in childhood, in the form either of cylindrical-celled carcinoma or of sarcoma, is very rarely met with. Allingham<sup>1</sup> reports the case of a boy thirteen years of age who suffered from cancer of the rectum, and another case in a lad of seventeen years; and a few similar cases have been reported by Quain, Cripps, and other observers.

**Diagnosis.**—The diagnosis of this affection is to be made from the non-malignant growths of the rectum, and will depend largely upon the presence of the peculiar cachexia of cancer. The prognosis is extremely unfavorable.

**Treatment.**—The treatment of malignant disease of the rectum consists in the excision of the growth if its situation is favorable for such a procedure; or linear rectotomy, which consists in freely dividing the growth, together with the lower portion of the rectum, including the sphincter, may be practised, with at least temporary benefit; or, if excision is not possible, owing to the fact that the growth involves a high portion of the rectum, and if symptoms of obstruction of the bowels are present, colotomy should be performed.

#### WOUNDS OF THE RECTUM.

Wounds of the rectum may be caused by bodies introduced through the perineum or the anus or by substances which reach the rectum through the alimentary canal. They may be lacerated, incised, or punctured. Severe lacerated or punctured wounds may result from patients falling upon sharp bodies which enter through either the perineum or the anus, or from sharp fragments of broken bones of the pelvis, causing in many cases extensive laceration of the parts about the rectum as well as of the rectum itself, and these wounds may be complicated by injuries of the bladder, vagina, or peritoneum. Many cases of severe punctured or lacerated wounds of the rectum have resulted from the careless or forcible introduction of the nozzle of the enema-syringe. The laceration of this organ in children who have been subjected to unnatural intercourse should also be mentioned. The most common varieties of incised wounds of the rectum are

<sup>1</sup> *Loc. cit.*, p. 230.

those resulting from operations upon that organ or from the accidental incision of the bowel in the operation of lateral lithotomy.

Among the unusual forms of injury to the rectum might be mentioned a recently reported case in which the injury partook of the nature both of a burn and of a wound, a blacksmith having thrust a red-hot bar of iron into the rectum of a boy who was sitting on a grating over his shop, the bar entering the bowel for several inches and inflicting a distressing burn which proved fatal in a few days.<sup>1</sup> Bodies also which have passed through the alimentary canal have been known to produce serious injuries of the rectum.

**Prognosis.**—Incised and lacerated wounds of the rectum which do not involve the bladder or peritoneal cavity generally heal very promptly, as is seen in wounds made by the surgeon in operations upon this organ, or in the accidental wounds occurring in the lateral operation for stone in the bladder; but in deep lacerated wounds in which the above complications exist, and in punctured wounds in which there is not adequate drainage, the prognosis is not so favorable. In lacerated and punctured wounds of the rectum the greatest danger results from hemorrhage and cellulitis, and when they are complicated by visceral injury or wound of the peritoneum the risks of urinary infiltration and peritonitis may be superadded, rendering them a most grave class of injuries.

**Treatment.**—The treatment of the simplest variety of incised or external lacerated wound of the rectum, which involves only its lower portion, consists in controlling the bleeding by the application of ligatures to the bleeding vessels, in washing the wound thoroughly with a solution of the bichloride of mercury from one in two thousand to one in four thousand, in dusting the wound with powdered iodoform, in providing for free drainage by the introduction of a drainage-tube, and in bringing the edges of the wound together with catgut sutures. A gauze dressing should then be applied, and the bowels kept quiet for a few days: under this treatment repair usually takes place promptly.

In punctured or internal lacerated wounds of the organ which do not extend high enough to involve the bladder or the peritoneum, it is considered advisable, in order to secure free drainage, to convert the internal punctured or lacerated wound into an open wound by the division of all the tissues, including the external sphincter and the skin, as would be done in the case of internal fistula. The wound should then be washed with a bichloride-of-mercury solution, packed lightly with iodoform gauze, and allowed to heal by granulation, the dressings being changed only as often as they become soiled. In cases complicated by a wound of the bladder perineal cystotomy has been recommended, to provide for the free escape of urine: in the case of a boy who suffered from a wound of this nature Mr. Bryant<sup>2</sup>

---

<sup>1</sup> British Medical Journal, 1882, p. 25.

<sup>2</sup> Medical Times and Gazette, May 25, 1878.

adopted the above procedure, with a favorable result. Free drainage is also to be secured by division of the anal sphincter, and by the introduction of drainage-tubes if necessary. If there is evidence of puncture of the peritoneum, with injury of the contained viscera, the surgeon should perform laparotomy, and wounds of the viscera, if found, as well as the rent in the peritoneum, should be closed by sutures.

#### FOREIGN BODIES IN THE RECTUM.

Foreign bodies may enter the rectum from the upper part of the alimentary canal or may be introduced through the anus: in the former case they may consist of masses of fecal matter which have become inspissated or of substances which have been swallowed and have been arrested in their passage through the rectum. The greatest variety exists in the foreign bodies which have been introduced, either by accident or by design, through the anus into the rectum.

**Symptoms.**—The symptoms of a foreign body impacted in the rectum are pain, ineffectual attempts at defecation, and the passage of mucus or blood-stained mucus.

**Diagnosis.**—The diagnosis of the condition producing these symptoms can be made by a careful exploration of the rectum with the finger, which will enable the surgeon to assure himself of the presence, the character, and the exact location of the foreign body.

**Treatment.**—The treatment of foreign bodies impacted in the rectum consists in their removal with the least possible injury to the walls of the organ. To do this satisfactorily it is well first to anesthetize the patient and then to inject into the rectum a few ounces of olive oil. When the character and the position of the body are ascertained, it may be dislodged by the finger and removed by means of forceps. Large masses of inspissated material may require fragmentation before their removal can be satisfactorily accomplished. Where the body is irregular in shape, or possesses sharp edges or angles which may cause injury to the lower part of the rectum or anus, the introduction of retractors or of a bivalve speculum and full dilatation of the anus and of the lower portion of the rectum will greatly facilitate its removal without injury to the rectal walls.

If after removal of the foreign body it is found upon examination of the rectum that ulceration has resulted from its presence, a solution of nitrate of silver, ten grains to the ounce of water, should be applied to the ulcerated surface, the patient kept in bed, the diet restricted, and suppositories containing iodoform introduced into the rectum. The possibility of stricture following this condition should not be lost sight of, and if cicatricial contraction supervenes it should be treated by the use of bougies.

# COLOTOMY.

By JOHN H. PACKARD, M.D.

---

THE operation of colotomy, or the making of an opening in the wall of the large intestine,—an artificial anus,—is occasionally required in children for the relief of congenital malformations of the rectum, in order to give free exit to the contents of the bowel. I am not aware of any recorded instance of its performance in childhood for any other reason. When the gut terminates in a blind pouch, the condition is one which, if not speedily remedied, will destroy life: so that in such cases operative interference is needed within a very few days of birth, and the earlier it is resorted to, the better.

The subject of these congenital malformations, and of their varieties, is elsewhere discussed: we are here concerned only with the operations to be contemplated when the bowel cannot be reached and opened through the perineum.

When in a newly-born child this condition of things is found to exist, it becomes the duty of the attendant to inform the parents of its very grave significance, and to propose to them an operation, as affording the only possible chance of saving the infant's life. The opinion has been very strongly expressed by some surgical writers of high authority that it would be better to let a child die than to prolong its existence in the loathsome and distressing state which they think must be brought about by the formation of an artificial anus. Such an idea is not, however, borne out by experience; in many cases, and probably in all by proper care, the child can be made as comfortable and kept as clean as if the feces were discharged by the natural channel. And it may be questioned, even if this were not so, whether the rule of professional conduct should not be to preserve life under any circumstances. Certainly the responsibility of declining interference should be placed upon the friends.

Moreover, the performance of this operation of opening the colon and giving exit to its contents need not be regarded as a finality; it may be done, and perhaps always should be done, with a view to further measures for the establishment of the natural passage, after which the closure of the artificial orifice may be attempted.

Practically, there are two points to be considered as eligible for the

opening of the colon in these cases. One is the descending portion of the gut, reached by an incision in the left loin; the other is the sigmoid flexure, accessible from one or the other groin, usually the left. (In the adult the cæcum may be opened in the right groin, or the ascending colon in the right loin; but neither of these procedures is proper in cases of imperforate rectum, since the large portion of bowel below the site of operation would constitute a cul-de-sac in which fæcal matters would accumulate and give trouble, while there would be no chance for further effort at establishing the natural passage by means of the opening thus made.)

The chief peculiarity of these operations in children consists in the small size of the parts, and the delicacy of the tissues, making the manipulations difficult; moreover, the rules laid down for their performance in adults will not apply here.

*Colotomy in the left loin*, often called Amussat's operation, has for its object the exposure and opening of the posterior wall of the descending colon, avoiding, if possible, interference with the peritoneum.

Anæsthesia is not necessary in any of these procedures, and in the case of a very weakly child might add an element of shock which would be very undesirable. If, however, a strong child should by its cries and struggles interfere with the making of a careful examination, a few whiffs of ether may be given to quiet it.

Antiseptic precautions ought certainly to be observed. It is true that the escape of meconium will subsequently make it difficult to keep the wound clean, but the early healing of all but the fistulous orifice will be favored, and, which is very important, the risk arising from any accidental interference with the peritoneum will be greatly diminished.

The child should be carefully wrapped up in suitable flannels, only the part to be operated on being exposed. It should be laid upon a table of proper height, on a pillow, in such a position as to make the left loin prominent,—viz., on its right side, but turned somewhat on its face. A good light is absolutely essential.

The instruments required are a scalpel, a probe-pointed bistoury, dissecting- and artery-forceps, tenaculum, scissors, grooved director, small retractors for keeping the edges of the wound apart, fine catgut ligatures, needle-holder and curved needles, and silk and silkworm-gut for sutures. All these, thoroughly sterilized, and placed in carbolized water, should be within reach either of the operator or of a skilled assistant.

My own rule, which I have always found reliable, is to begin at the upper and outer corner of the quadratus lumborum muscle,—a point easily found,—and to cut the skin downward and outward in a line at an angle of forty-five degrees with a vertical one, nearly to the crista ilii. I divide the skin obliquely, so that one edge is bevelled at the expense of its outer surface and the other at the expense of its inner,—this plan making the subsequent closure of the wound more complete, and favoring healing, especially as the access of fæcal matter to the cut surfaces is rendered well-

nigh impossible. The deeper tissues are divided layer by layer, to the same extent as the incision through the skin: this is very important, as otherwise the operator would finally find himself working at the bottom of a funnel-shaped hole, and at a great disadvantage. A layer of firm fascia is soon reached, which being divided, a mass of fat is seen, beneath which the colon will be found. Sometimes a few fibres of the transversalis muscle are cut at the outer edge of this fascia. During this dissection, all vessels which may spring should be carefully tied with fine catgut.

By means of the retractors, the wound is now held open, while the surgeon works through the fat with the knife-handle and his finger. Occasionally the outer edge of the kidney is in the way, and must be cautiously pressed inward (towards the median line). If distended with meconium, the bowel will presently be felt as a smooth, rounded, doughy mass, and may be exposed to view. It is of a dull grayish-yellow color, with the dark-green meconium showing through it; often one of the longitudinal muscular bands is also seen.

On satisfying himself that it is the bowel which he has before him, the surgeon takes a small curved needle, armed with a silk ligature, and carries it through the wall of the gut just above the middle of the exposed portion, bringing it out again at a point an eighth of an inch distant, and on the same level; he then repeats the process half an inch lower down, and thus has two loops of thread by which control of the gut-wall is secured. Drawing it outward, and giving the ends of one of the loops to an assistant, the wall may be made tense, and divided with the point of the scalpel, upon which meconium will at once escape. The wound may be protected from contact with this material by means of a flat aseptic sponge or a layer of sublimated cotton.

The size of the opening to be made must be a matter of judgment with the operator. If too small, it will be apt to contract, and will be insufficient for the escape of fecal matters. If too large, the mucous membrane will prolapse through it, and is apt to become very sore; besides which, there will be too free and constant discharges, making it almost or quite impossible to keep the child clean.

The edges of the opening in the gut are now everted, and carefully fastened to the skin by four or six points of suture with silk thread; the remainder of the wound above and below is then accurately closed with silkworm-gut sutures, carried deeply, so as to effect entire apposition of all the tissues. Iodoform is next dusted over the surface, and a thick layer of sublimated or borated cotton applied, kept in place by a flannel binder.

The operation now described does not involve any special danger. In the only instance in which I have resorted to it in the living child, there was no difficulty whatever; but a few hours afterwards, copious oozing of blood ensued, and was checked only by the application of tannin upon cotton, several other measures having been tried in vain. The overlapping of the gut by the kidney may be a source of some embarrassment, but has

never, so far as my knowledge goes, prevented the surgeon from proceeding. A more formidable hindrance may occur in the difficulty of finding the bowel, which may be due to either of two causes,—the existence of a wide mesocolon, like the mesentery, so that the colon floats out in the abdominal cavity instead of lying embedded in the circum-renal fat, or the absence of fecal contents, the tube being empty and contracted. The latter condition has been found in several instances to be due to atrophy affecting the whole of the large intestine. In the former case, if the mass of the distended colon were made out by its being crowded back by pressure on the belly in front, the opening and securing of its wall might be effected in the same way as described above, the peritoneum being slit, and the bowel drawn through the orifice. Should this be done, care should be taken in the suturing to insure accurate and close coaptation of the two serous surfaces.

Ordinarily the peritoneum is in no danger in an operation of this kind; but if by any awkwardness or mischance it should be nicked or torn, the edges of the rent should be at once caught up, and a fine catgut ligature applied around the part, so as to close it like the drawing-string of a bag.

*Colotomy in the groin*, often called Littre's operation, or inguinal colotomy, has for its object the opening of the colon in its sigmoid flexure. The remarks made as to anesthesia, antiseptics, and instruments, in reference to the operation in the loin, are applicable here, and need not be repeated.

Any one familiar with the anatomy of the adult only, if asked in which groin he would expect to find readiest access to the sigmoid flexure, would unhesitatingly reply, in the left. But in 1858 M. Huguier made to the Académie Impériale de Médecine in Paris the statement that the condition of the gut in new-born children was such that the sigmoid flexure occupied the right groin, and hence that the operation should be done on this side rather than on the left. To test the correctness of this view, careful researches were made by several observers, and the results are given by Giraldès.<sup>1</sup> He himself found, in one hundred and thirty-four autopsies on children, the sigmoid flexure at the left side in one hundred and fourteen; he collated fifty instances of Littre's operation, in all of which this was the case, as also in thirty autopsies on children operated on for atresia ani. Bonreart found it so in one hundred and seventeen out of one hundred and fifty, and Curling in eighty-five out of one hundred cases. The sigmoid flexure was thus on the left side in three hundred and ninety-six out of four hundred and sixty-four cases, or about eighty-five and one-third per cent. But, strange as the assertion may seem, it does not appear that in the other sixty-eight cases the sigmoid flexure, or an available portion of it, could not have been reached from the left side as well as from the right.

Goëde<sup>2</sup> advocates Huguier's view, and gives a very elaborate theory as

<sup>1</sup> Dict. de Méd. et de Chir. pratiques, 1865, tome ii., art. "Anus."

<sup>2</sup> Jour. de Méd. et de Chir. pratiques, tome xlix., December, 1878.



to the reasons why such a disposition of the intestine should obtain. It seems to me, however, that the matter is susceptible of a simple explanation. The comparatively very small size of the pelvis being remembered, the thinness of the intestinal wall, and the accumulation of meconium during intra-uterine life, it will be obvious that the large bowel will be loaded to distention, and that the sigmoid flexure must be swollen, the arc of its curvature being increased, and the mass pressing in the direction of least resistance. In this way it may be that a large part of the sigmoid flexure may be met with in the right groin, but its lower portion must run backward to its anchorage in front of the sacrum. With antiseptic precautions the peritoneum, being necessarily opened on whichever side the operation is one, may be explored with an antiseptic finger, and the bowel found.

My own preference, therefore, would always be for the left groin.

The child is to be laid on the back, the thigh very slightly flexed on the trunk. An incision about an inch and a half in length is made parallel with Poupart's ligament, and about half an inch above it, beginning near the anterior superior spine of the ilium. Layer by layer the tissues are divided to the same extent, until the transversalis fascia is reached and opened, when the peritoneum will be exposed. Any vessels which spring are to be securely tied with fine catgut. The peritoneum being nicked and divided on a director, the operator passes a clean and aseptic finger into the abdominal cavity to feel for the gut. If this bulges into the wound, it is at once caught; if not, when found it is coaxed down, pushing the other intestines out of the way. As soon as it comes into the wound, it is caught with a hook or with toothed forceps, and two silk sutures passed through the wall, so as to obtain control of it. By means of the threads it is now drawn well through the wound, and four silver-wire or silk sutures are passed, two through all the tissues at each edge of the wound, and then through the wall of the gut and out on its exposed surface. Between these, as nearly as possible at the centre of the exposed surface, the gut is now opened, and the edges of the opening are at once caught with forceps. Extreme care must be taken to prevent the escaping meconium from finding access to the peritoneal cavity. The silk or silver-wire sutures are now to be carefully secured by tying or twisting, additional points of suture between the skin and bowel-edge being placed if necessary. The remainder of the wound is now accurately closed with sutures of silkworm-gut. I think it is better to suture the deeper tissues and peritoneum with fine catgut first, and to let the silkworm-gut sutures secure the superficial tissues merely.

Finally, iodoform and borated or sublimated absorbent cotton are applied, as in the case of the lumbar operation.

*Colotomy in the right groin* does not differ in any important particular from the operation just described. In the adult it is sometimes resorted to with the purpose of opening the cæcum, the peritoneum being left intact; but in the infant such a procedure would be of necessity a mere palliative, and open to objections already stated.

The question of the comparative advantages of the two methods of opening the colon, which have now been described, naturally presents itself. Should the operation in the loin be preferred, or that in the groin?

One advantage offered by the lumbar incision, and the chief, is that, as a rule, the bowel can in this way be reached and opened without interfering with the peritoneum. This is a matter of less moment at the present day than it was in pre-antiseptic times. A more practically important point is that in case of failure to find the bowel at this spot, the wound can be at once closed, and a fresh attempt made elsewhere. Again, unless there be a wide mesocolon, this part of the gut is much more firmly fixed than is the sigmoid flexure.

On the other hand, the dissection required to expose the colon in the loin is deeper, and really more difficult, than in the groin. And the very fact of the depth and fixation of the bowel makes it less easy to deal with. Should further measures be contemplated, with a view to establishing an anus at the normal point in the perineum,<sup>1</sup> the lumbar opening affords less facility for so doing than the inguinal. Finally, in the event of the child's surviving to the age when it should attend to itself, an artificial anus in the loin would be much less conveniently placed than one in the iliac region.

In the inguinal operation the peritoneum is of necessity opened, and this fact, in spite of all antiseptic precautions as to the procedure itself, involves some risk of the entrance of meconium into its cavity. Such a mischance, which must inevitably prove fatal, cannot always be guarded against, and may have induced the peritonitis which is noted as a frequent cause of death in these cases.

The inguinal operation, however,—although, from what may be called a sort of traditional superstition among surgeons, it is looked upon as more formidable,—is in reality easier of performance than the lumbar. Some portion of bowel is always to be found here, and generally that which is wanted. Explorations downward for the purpose of establishing an anus in the perineum are much more readily made, since the distance to be traversed is much less than from the loin, and the route to be followed is less tortuous.

When the little patients survive, there are two annoyances to be feared, whichever operation has been chosen. One is the prolapse of the bowel through the artificial opening, the mucous membrane forming a projecting villous mass, with an orifice at either side, one leading into the upper portion of the tube, the other into the lower portion. This can be obviated only by proper pads held in place by bandages or adhesive plasters.

The other, and really the more troublesome, condition is the narrowing

---

<sup>1</sup> A case of this kind, in which, considering the unfavorable circumstances surrounding it, a really brilliant success was obtained, was reported by Dr. W. H. Haynes, of New York, in the *American Journal of the Medical Sciences* for July, 1884. The child, at eleven months of age, was in good condition locally, in spite of neglect on the part of its parents: its death, which took place some time afterwards, was ascribed to convulsions incident to teething.

of the orifice so that the escape of *fæces* is hindered. Division of the tissues with the knife, under such circumstances, should be very cautiously done, if done at all. A safer plan is to use some means of dilatation, as a sponge or laminaria tent, or plugs, like sections of rectal bougies, gradually increasing in size until the opening is made sufficiently free. Laxatives and injections must, of course, be used if the *fæcal* mass is too firm to be readily expelled. The process of dilatation may need to be repeated again and again, as the contraction recurs.

When we look at the published records and statistics of these operations, it is clear that this is not one of the fields in which surgery has been brilliantly successful. Very possibly in many cases the malformation is merely a local expression of a general deficiency of developmental power, and the children so affected are in other respects wanting in vigor. Certain it is that very few of them pass the period even of infancy.

The most available statistics on this subject are not recent. They are those of Curling<sup>1</sup> and Giraldès.<sup>2</sup>

Curling gives a table of one hundred cases, operated on in various ways; those which concern us here are the twenty-three in which colotomy was performed. Of these, the gut was opened in the loin in eight, with two successes; in the remaining fifteen the inguinal operation was done, with ten successes. Both of the successful lumbar operations were performed by Amussat; the subject of one was known to be living and well at the age of seven years, but the other was reported to have died at about two months.

Giraldès gives a table of thirty-four cases, all of them inguinal colotomies. Of the whole number, twenty-three died under one year of age; and of these, only three survived a month or more. One is said to have reached the age of fourteen months, and three that of two years. (One child, operated on at the age of four years, lived eight months afterwards.)

Among the remaining seven, Rochard, of Brest, is to be credited with one, the subject of which lived five years; Miriel, also of Brest, had one patient (included above) who lived two years, one who reached fourteen years, and another nineteen; two other of his patients attained adult age, one dying at twenty-two, the other at forty. A child operated on by Duret, also of Brest, grew up, and lived to the age of forty-three. The longest period of life secured in this way was in a case of Serrand's,—forty-nine years.<sup>3</sup>

Miriel's successes, referred to above, are unparalleled in the experience of any other surgeon, so far as any published records show; and it is fair to conclude that they stand alone. A very large number of reports of isolated cases may be found scattered over the pages of medical journals,

<sup>1</sup> *Medico-Chirurgical Transactions*, vol. xliiii., 1860.

<sup>2</sup> *Dict. de Méd. et de Chir. pratiques*, Paris, 1865, art. "Anus artificiel."

<sup>3</sup> These tables cannot be combined, partly because they overlap, some of the same cases occurring in both, but also because there are as to these some minor discrepancies which, not having access to the original reports, I have been unable to reconcile.

but in the great majority of them only a brief extension of life has been secured. Some of these patients, indeed, are lost sight of by the operators, and may have lived to grow up; but it would be strange if there were many such who failed to attract the observation of medical men in their later years, in which case the fact would almost certainly be made known to the profession.

When we try to investigate the cause of the very large proportion of deaths among children operated on for malformations of the rectum (no matter what the special lesion or the procedure adopted), we find that in very many of the cases it is stated that the patients did well for a time, and then began to fall away, dying from exhaustion; in others we find that they are said to have succumbed to some of the milder diseases incident to childhood. And therefore it seems to me reasonable to suppose that these malformations may be properly regarded as not only mere local defects of development, but also, or perhaps as such, as significant of a constitutional want of force, so that the subjects of them are prone to pass into an adynamic condition, or, when attacked by the diseases of childhood, to lack the power to make a successful resistance.

The condition of imperforation of the rectum is a certainly fatal one: the operation of opening the colon does not in itself involve any serious risk; it presents no great difficulty to any one with proper anatomical knowledge and average surgical dexterity; and it will at least afford palliation of the sufferings of the little patient. An opportunity may perhaps be made in this way for further measures, looking to the establishment of an anus in the normal position.

Under these circumstances, it seems clear that the resort to operative interference is not only justifiable, but also imperatively indicated. The best chance of success, in the light of past experience, is in the operation in the left groin; and it should be done at the earliest practicable moment. Such procedures can hardly be instituted with sanguine expectations of brilliant results, but it is well worth while to undertake them merely with the object of alleviating suffering.

# DISEASES OF THE PANCREAS,

AND

## THEIR OPERATIVE TREATMENT.

By N. SENN, M.D.

---

### TOPOGRAPHICAL ANATOMY OF THE PANCREAS.

FOR a correct interpretation of the signs and symptoms of the different diseases of the pancreas, and for an accurate understanding of the relations of this organ to surrounding parts in their surgical treatment, it becomes necessary to refer to the topographical anatomy of the pancreas. The pancreas is a tongue-shaped gland placed transversely in the abdomen, at a point opposite the first lumbar vertebra, behind the stomach, reaching from the hilus of the spleen to the concavity of the duodenum. Its right end, termed the head, is embraced by the curvature of the duodenum, whilst its left or caudal extremity is in contact with the spleen. After opening the abdominal cavity in cadavers, it can be distinctly felt as a firm body through the walls of the stomach. The organ is made accessible and exposed to sight by cutting the ligamentum gastro-colicum transversely, and by pushing the stomach upward and the transverse colon downward. In the sacculus epiploicus, which has now been opened, the gland is seen in front of the large vessels. It presents three surfaces for examination. The anterior surface, somewhat concave, is in contact with the stomach throughout its entire extent, but separated from it by a covering from the omental bursa which renders the surface smooth and well adapted for the free movements of the stomach. The posterior surface is separated from the spine by the vena cava, the aorta, the superior mesenteric artery and vein, the pillars of the diaphragm, and, towards the liver, the vena porta, as well as by numerous lymphatic vessels and glands, all of which are firmly connected with this surface, and the spine, by connective tissue. To the left of the vertebral column it is attached in the same manner to the left suprarenal capsule, kidney, and renal vessels. The superior mesenteric artery and vein are embraced by the substance of the gland, so as sometimes to enclose these vessels in a complete canal. The inferior surface is narrow and di-

rected towards the transverse colon, the right end resting on the junction of the duodenum and jejunum, and the left on the extremity of the transverse colon. The intervening middle portion of the inferior surface has a special peritoneal covering derived from the lower layer of the mesocolon. Along the posterior surface and upper border of the gland are placed the splenic artery and vein, both pursuing a tortuous course from right to left. The cœliac axis is above the pancreas. The common bile-duct is in close relation to the head of the gland, passing down along its posterior surface, and is generally received into a groove or canal in its substance.

The common pancreatic duct, or canal of Wirsung, is widest near its entrance into the duodenum, where it is from one-twelfth to one-ninth of an inch in diameter. Before its termination it unites with the common bile-duct in the wall of the intestine, at the junction of the second and third portions of the duodenum, between three and four inches below the pyloric orifice of the stomach. The lower extremity of the head, where it curves behind the mesenteric artery and vein, is sometimes marked off from the rest, and is then called the *lesser pancreas*, with a special duct which joins the common duct in the substance of the head of the pancreas. The pancreas receives its blood-supply from the superior and inferior pancreaticoduodenal branches of the hepatic and superior mesenteric arteries. The venous return takes place through the splenic and superior mesenteric veins. The nerves are derived from the solar plexus.

#### ACCESSORY PANCREAS.

The pancreas, like many other glandular organs, sometimes presents rudimentary duplicities, and it is necessary to call attention to this fact for the purpose of considering the possibility of the origin of a pancreatic cyst from one of these appendages. Rokitansky mentions, as an exceedingly rare occurrence, duplicity of the pancreas and excessive development of accessory appendages. A frequent variety is represented by the head of the gland,—the *pancreas minus*,—the duct of which usually terminates in the common duct, but sometimes, as was first ascertained by Winslow, takes an independent course and empties into the duodenum from an inch to an inch and a half below the opening of the common duct. More recently, Hyrtl has called attention to an accessory pancreas consisting of a few isolated acini of the gland behind the superior mesenteric artery and vein. Klob has described an accessory pancreas distinct from the normal organ, which was found between the muscular layers of the stomach, about the middle of the great curvature. On another occasion he found a similar organ in the posterior wall of the jejunum, near its upper termination. In both instances the glandular structure of these bodies was proved by microscopical examinations.

Zenker met with six instances of supernumerary pancreas. The accessory organ was invariably in the walls of the intestine, three times in the highest convolution of the jejunum, twice near the duodenum, and in the

last case in the upper portion of the intestinal tract. In size the glands varied from that of a lentil to that of a silver dollar. They were situated between the intestinal tunics, and presented a prominence on the serous surface. Klob found no excretory duct in his specimens. Zeuker detected the terminal end upon the mucous surface of the intestinal canal in the shape of a slightly-raised papilla which could be seen with the naked eye or by means of a magnifying-glass. The presence of pancreatic juice in the glands was also determined. In all instances the gland proper was found in its normal location and of natural size. All the patients were adults.

Like other accessory organs, the supernumerary pancreatic glands owe their origin to embryonal deposits of gland-tissue. Although, as yet, no instance has been observed of cystic formation from an accessory pancreas, there is no reason why such an occurrence should not take place, in the same manner as has been observed in cases of cysts from supernumerary thyroid glands, and for the same reasons.

#### DEVELOPMENT OF THE PANCREAS.

Remak has studied the development of the pancreas in the young chick. He found that the matrix could be seen somewhat later than that of the liver, about sixty-five hours after incubation had commenced. It consists primarily of a bulging of the hypoblast of the posterior wall of the intestinal tube, covered by a thickened prolongation of the connective-tissue layer of the bowel. (Fig. 1.)

The embryonal pancreas shows in the beginning a cavity which is in communication with the open lumen of the bowel. The changes which take place in the embryonal pancreas during the first five days can be readily observed and are easily understood.

From the thick wall of the hypoblast numerous small, solid lobules spring, while the hollow space in communication with the bowel assumes more and more the shape of a canal. The connective-tissue layer does not increase in size in the same degree, and presents no lobular projections upon its surface. On this account the new organ has assumed a pyriform shape externally; on the other hand, the glandular portion in the connective-tissue layer takes on a branched structure.

The hypoblastic layer is the basis of the parenchyma. Composed of cells, the connective-tissue layer serves as the basis for the vascular constituents of the gland. The embryonal connective tissue disappears during the development of the gland in proportion as the cellular portion increases, until, finally, only enough connective tissue is left to serve as a nidus for the vessels and as a membrana propria of the acini.

FIG. 1.

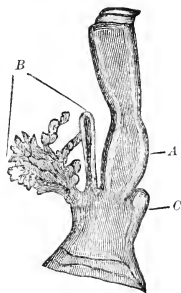

EMBRYO OF CHICK, FOUR DAYS OLD.—A, stomach; B, liver and bile-duets; C, pancreas.

The pancreas is not developed by symmetrical folding of both walls of the intestinal canal, but each wall grows by proliferation in different degrees to form the pancreas. The excavation in the rudimentary gland does not exist at first, but the original and essential structures are the cellular parenchyma of the gland from the epithelial lining of the intestine, and the vessel- and nerve-enveloping layer of connective tissue. As the pancreas in birds has two ducts, the question arose how the second duct is formed. The most plausible explanation was afforded by the assumption that the primary duct divides into two in a longitudinal direction. Remak, in 1864, found another explanation by examining two geese, between three and four weeks old. He found two ducts at a short distance from each other in connection with the wall of the intestine. A closer examination showed, however, that only one of the ducts, the upper, was in communication with the lumen of the intestine; the other presented a blind pouch adherent to the wall of the intestine.

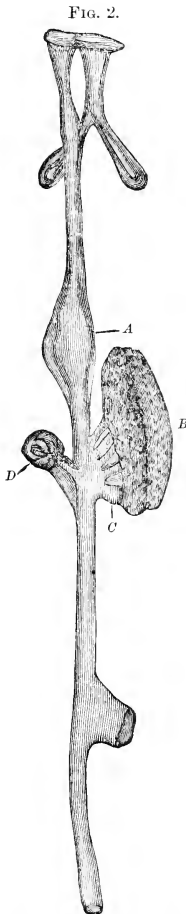

EMBRYO OF CHICK, FIVE DAYS OLD.—*A*, stomach; *B*, bile-duct; *C*, gall-bladder; *D*, pancreas.

From this it may be concluded that the second duct springs from the first, and that at a later period a new communication with the bowel is established at a point corresponding to its caecal extremity. Remak has since observed the same condition in the larvæ of frogs. It appears, then, established that the primary duct of the pancreas is found in

the larvæ of frogs. It appears, then, established that the primary duct of the pancreas is found in

the larvæ of frogs. It appears, then, established that the primary duct of the pancreas is found in

FIG. 3.

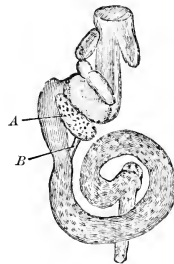

LARVA OF FROG.—*A*, pancreas; *B*, pancreatic duct.

the rudimentary organ, and is from the beginning in communication with the bowel, while any additional ducts, whether normal or anomalous, originate in the substance of the gland and only secondarily are brought into



communication with the bowel by a process of atrophy and absorption between the cæcal extremity of the duct and the intestinal wall.

The existence of anomalous ducts communicating with one of the principal ducts and the intestine can be explained in a similar manner. Thus, in dogs it is not uncommon to find a small duct in the gastro-splenic half of the gland, connecting the intestine, at a point where the common bile-duct opens into the intestines, with the common duct, as illustrated by a specimen in my possession.

It is apparent that in cases of this kind obliteration of the common duct on the distal side of the anomalous or accessory duct would not interfere with the normal evacuation of the secretion into the intestinal canal. The occurrence of an accessory pancreas can be explained only by the assumption that during the growth of the rudimentary pancreas certain portions of the secreting structure become isolated by constriction and displacement, and that such portions of the gland are brought into communication with the intestinal canal by the development of an accessory duct.

#### PHYSIOLOGY OF THE PANCREAS.

A brief consideration of the most important functions of the pancreas becomes necessary as an introduction to a study of the diseases and injuries of this organ, as it will serve to furnish an interpretation of some of the symptoms which are observed in the course of affections which interfere with the normal secretion or outflow of the pancreatic juice.

Claude Bernard, in 1848, discovered the most important function of the pancreatic juice, by observing its emulsifying action upon all kinds of fat. He found that by mixing fresh pancreatic juice with oil, lard, butter, or tallow, and keeping the mixture at a temperature of 35° to 40° C., an emulsion is formed almost immediately. Saliva, gastric juice, bile, and blood-serum do not produce this effect. The emulsifying process takes place by the division of the fat into minute globules by the pancreatic juice without its conversion into a new chemical compound. The organic principle in the juice which possesses this property is very easily decomposed and precipitated by heat. Bile with pancreatic juice dissolves neutral as well as acid fats. Bernard ligated both pancreatic ducts in dogs, and the single duct in rabbits, and fed the animals on fat. The fat was found unchanged in the intestinal canal, and the lacteals were empty. Fatty diarrhoea has been observed in a number of cases where the pancreas was the seat of extensive lesions, and the presence of this symptom should always lead the physician to make special search for additional symptoms confirming the suspicion of the existence of disease of the pancreas.

There is no dispute among physiologists in regard to the action of pancreatic juice in transforming starch into sugar. This function was first observed by Valentin, in 1844, who experimented with an artificial fluid made by infusing pieces of pancreas in water. Bouchardat and Sankras first observed this property in the normal pancreatic secretion. The

property of converting starch into sugar is possessed also by the saliva and the intestinal juice; it therefore becomes an important question to determine the effect of a defective pancreatic secretion in cases where there is imperfect digestion of starchy food. It seems that cane-sugar is transformed into glucose almost exclusively by the action of the pancreatic juice. This fact has received confirmation in the case of intestinal fistula observed by Busch. The fistula was located in the lower portion of the small intestine. When cane-sugar was introduced in quantity into the stomach, fasting, the fluid which escaped from the upper end of the intestine contained a small quantity of glucose, but never any cane-sugar. Cane-sugar introduced into the fistula so that it would pass along only the lower end of the bowel was not converted into glucose, but a large portion of it was found in the fæces as cane-sugar. In cases of suspected organic lesions of the pancreas it would therefore appear advisable to resort to feeding with cane-sugar and to subsequent examination of the stools for undigested cane-sugar, as a diagnostic measure. The presence of cane-sugar in the stools would indicate that little or no pancreatic juice is secreted.

The last function of the pancreas consists in converting, with the aid of the bile and intestinal juice, the albuminoids, such as gluten, fibrin, albumen, caseine, and musciline, into albuminose or peptones. This latter effect of the pancreas has been doubted by a number of German physiologists, but the fact seems to be demonstrated by experiment as well as by the circumstance that the pancreas is larger in carnivorous than in herbivorous animals.

Schiff has found that the physiological function of the pancreas is at its maximum about nine hours after the ingestion of food, and at its minimum from four to six hours later. During the greatest activity of the gland the vessels become more turgid, and can be seen with the aid of a lens between and upon the lobules, while during a state of rest they are seen only between the lobules. During digestion the gland presents a pale-red color, while during rest it appears grayish white.

The influence of the nerve-centres upon the pancreas has been made a subject of careful study by Schiff. Section of both pneumogastric nerves has no effect upon the circulation or secretion of the pancreas. Animals subjected to this experiment readily digested dextrin or peptones introduced into the stomach; but if ordinary food was given, no secretion took place, as stomach-digestion was suspended. Total destruction of the three semilunar ganglia of the sympathetic arrests completely the secretory functions of the pancreas, even if the most favorable conditions are established by the introduction of food or injection of the products of digestion into the stomach. Wounding of these ganglia, short of total destruction, does not produce the same effect. Injury of the spinal cord on a level with the eighth, ninth, or tenth rib does not interfere in the least with stomach-digestion, but promptly arrests all secretion from the pancreas, which cannot be excited by food nor by the presence of dextrin in the stomach. Heiden-

hain has ascertained that stimulation of the medulla oblongata increases the flow of pancreatic juice as well as its active constituents. These experiments show that the reflex action of the stomach upon the pancreas is not transmitted through the sympathetic, but through the spinal cord. That the essential active principle of the pancreatic juice is necessary for digestion has been shown by Corvisart, who found that in dogs the pancreatic juice contained, nine and a half hours after a meal, no ferment which was capable of dissolving albuminous substances. If, however, the animal was made to fast for a longer time than this, the ferment was again produced, in some unknown manner. Pancreatic digestion becomes apparent six or seven hours after a meal, the time being somewhat dependent upon the duration of digestion.

The present views concerning the action of the pancreatic juice in the process of digestion may be summarized as follows:

1. Starch is converted by a diastatic ferment into dextrin and sugar, a continuation of the action of the saliva in the intestine.

2. Melted and fluid fats are emulsified by it (a property which has been assigned in a less degree to bile); at the same time, glycerin and fatty acids are formed during the process. The emulsifying process is aided by the fatty acids and alkaline salts which effect saponification. (Brucke, Gad, Quineke.)

3. Albuminous substances and glue-containing tissues when mixed with an alkaline solution are dissolved and converted into peptones, independently of stomach-digestion (Corvisart). A portion of the peptones undergoes still further changes: as, in the case of albuminoid substances, leucin, tyrosin, xanthin, and sarcin, and in the case of glue, tyrosin, glycin, and ammonium, may appear.

Fresh pancreatic juice obtained from the duct of Wirsung is a clear, viscid, alkaline, highly putrescible fluid, of a specific gravity of 1030, which solidifies completely on boiling. Pancreatic juice contains (1) albumen, (2) a number of ferments, (3) salts, especially of soda, (4) water; sometimes traces of self-digestion of the juice can be found, especially leucin. (Hermann.)

The pancreas secretes continually in herbivorous animals; in carnivorous, only during digestion (Heidenhain). The ferments are always present in the gland, trypsin only in a state of preparation, a so-called zymogen, which on division yields trypsin; this division takes place on exposure of the gland to air, to the action of oxygen, of very dilute alkalies, acids, alcohol, etc. During secretion the cells of the lobules are enlarged, while the lobules become swollen; at the same time the vessels are considerably dilated. The exact quantity of pancreatic juice secreted in man and most animals is unknown.

From a practical point of view, it is important to refer to the effect of the pancreatic juice upon the skin, which it macerates, so that when the skin remains in contact with the fluid for any length of time it becomes

irritated and presents a raw, eczematous surface. It also appears that the same effect is not produced when the fluid is brought into contact with the peritoneum, because in this locality fresh pancreatic juice is removed rapidly by absorption.

A positive diagnosis of disease of the pancreas will become possible only when more attention shall be bestowed upon the symptoms arising from defective digestion the result of a defective or faulty function of the pancreas,—a pancreatic indigestion. Long-continued indigestion of fatty or starchy food should be considered a sufficient indication for instituting a most careful search for pancreatic disease, by ascertaining the effect upon digestion of particular articles of diet, and by examining with care the discharges from the bowels.

#### WOUNDS.

Of all abdominal organs the pancreas is most exempt from injury by both direct and indirect violence, a circumstance which is entirely due to its remote location and to the ample protection furnished by the vertebral column and the bony walls of the chest. The anatomical relations of the pancreas to numerous and important organs are such that when this organ is injured the same violence which produced the injury has also wounded an adjacent and perhaps more important viscus. The frequency with which such grave complications accompany wounds of the pancreas and the profuse hemorrhage usually attending such injury are elements of danger which impart to wounds of the pancreas more than an ordinary degree of gravity. Contused wounds of the pancreas, such as are caused by the passage of the wheel of a carriage or wagon over the region of the abdomen corresponding to the location of the pancreas, are attended by such serious injury of one or more of the adjacent organs that in all the cases so far reported death has followed within a few hours. A number of well-authenticated cases are on record where in penetrating wounds of the abdomen the pancreas protruded in part, and the prolapsed portion sloughed or was removed, and yet the patients recovered.

Laborderie reports the case of a girl, aged ten years, who had fallen, while running, upon an open pocket-knife, which inflicted a wound two centimetres below the lower border of the rib, and three finger-breadths to the right of the median line, extending outward for one and a half centimetres, almost horizontal, with a little inclination from above downward. The pancreas was found strangulated in the wound so tightly that not a drop of blood escaped. The author believed that the prolapse was caused by the screaming of the patient. The duct of Wirsung and vessels escaped injury. The abdomen was painless on palpation, and there were no signs of internal hemorrhage. The knife had entered the abdomen under the lobus Spigelii of the liver, and in its course reached the stomach, cut through the gastro-hepatic omentum, and then penetrated between the liver and pylorus to the pancreas, without injuring any of the many large vessels in the locality through which it passed. An attempt to replace the gland was only partially successful. The mass was transfixed and tied at its base with a double ligature, and the portion outside of the ligature removed with the knife. After this procedure nausea and vomiting set in, which, however, soon subsided. The wound was treated by the use of cold-water applications. On the third day the patient complained of being chilly, and the abdomen became

somewhat tympanitic and tender on pressure. These symptoms soon subsided, and the ligatures sloughed through, leaving a granulating surface, which healed in fourteen days. Recovery was complete in three weeks.

Hyrtl and Klebs are incredulous as to the prolapse of the pancreas in this case: they believe that the mass which was ligated and removed was not the gland, but a portion of the omentum. Nussbaum, however, in speaking of visceral injuries of the pancreas, states distinctly that in penetrating wounds of the abdomen in the region of the pancreas this organ manifests a tendency to prolapse, and that this circumstance facilitates the treatment, as it protects the peritoneal cavity against infection by plugging the wound, and at the same time affords better access to the bleeding vessels.

In not a single instance of the thirteen cases of injury of the pancreas which the writer has collected did symptoms during life first point to this organ as the seat of lesion. In all cases where the result was fatal, death was not attributable to the visceral lesion of the pancreas, but was always referable to injury of some adjacent organ. With the exception of cases of prolapse of this organ through a penetrating wound of the abdomen, the diagnosis and treatment of injuries of the pancreas will come under the observation of surgeons only in an incidental manner in the treatment of more tangible and graver lesions within the abdominal cavity. Contusion and laceration of the pancreas as independent conditions are not necessarily fatal injuries, and spontaneous recovery may take place, followed by absorption of the crushed portion of the organ and by atrophy of that portion of the gland which has become physiologically detached from the intestinal tract by the injury or its direct consequences. Crushing of the pancreas is usually not attended by hemorrhage, and in laceration of the organ the danger from this source is much less than in cases of incised wounds.

As modern surgery dictates not only the justifiability, but also the absolute necessity, of treating penetrating wounds of the abdomen, where visceral injury is suspected, by abdominal section, the surgery of the future will undoubtedly deal with contusions and lacerations of the pancreas in connection with visceral injury of some of its adjacent organs. If in exploring for injuries in this region the pancreas should be found extensively crushed, it would be good surgery to remove the crushed portion after preliminary ligation of the organ on each side of the comminuted portion. Ligation of the pancreas can be safely done with a single catgut or silk ligature, as the friable texture of the organ will permit of burying the ligature deeply, a circumstance which will guard against the slipping of the ligature. In not a single instance where this method of ligation was resorted to in the experiments on animals was secondary hemorrhage observed from inefficiency of the ligature. If the pancreas is lacerated, each end of the organ should be ligated, for the purpose of arresting or preventing hemorrhage, as well as to guard against extravasation of pancreatic juice into the abdominal cavity.

The results obtained by experiments on animals have demonstrated in

a satisfactory manner that normal pancreatic juice when brought in contact with the peritoneum does not produce inflammation, but is promptly removed by absorption. In the experimental work we always had the advantage of dealing with a normal serous surface, the absorption-capacity of which had not been impaired by antecedent pathological conditions, as would in all probability be the case in the operative treatment of injuries of the pancreas. At the same time, there can be no doubt that the presence of crushed pancreatic tissue and pancreatic juice in the peritoneal cavity after abdominal section would greatly enhance the danger of traumatic infection. For this reason, if for no other, the former should be removed, and the escape of the latter prevented by ligation of the pancreas on the side, or on each side, of the crushed or lacerated portion.

The cases of protrusion of the pancreas seem to establish the fact that a portion of this viscus may be separated by violence from the splenic artery and other important attachments, and may prolapse through an external wound, and under such circumstances can be removed without hazardous consequences. In most cases the prolapse followed some time after the injury from a sudden increase of intra-abdominal pressure, as coughing or straining at stool. Klebs and Hyrtl's objection to the possibility of a hernia of the pancreas can find a plausible support only by assuming that the relations of the pancreas have not been disturbed. If by the violence which produced the penetrating wound the attachments of the organ are severed, or in case the attachments have been abnormally loose, or the duodenum is supplied with a long mesentery, there is no tenable reason why the pancreas should not occasionally be found protruding through the external wound. Cases are on record where the pancreas constituted one of the contents of a diaphragmatic hernia, and an instance is reported where it formed a part of the intussusceptum in a case of invagination of the bowel (Bandl).

The treatment of prolapse of the pancreas will depend upon the pathological condition of the viscus at the time the patient comes under the care of the surgeon. If the prolapse is recent, and the organ presents no indication of inflammatory or other changes, it should be thoroughly disinfected and replaced. It is of the greatest importance not to resort to violence in effecting reduction, as irreparable damage may be inflicted by resorting to more than the gentlest force. When reduction is not readily accomplished, the wound should be enlarged. If the pancreas is in a condition of inflammation or gangrene, the parts should be thoroughly disinfected and the organ pulled farther into the wound until healthy tissue is reached, when a ligature is applied and the diseased portion removed with the knife or scissors. After another thorough disinfection the stump is dropped into the abdominal cavity and the external wound closed. Thorough primary removal of infected tissue is the only safety against subsequent extension of the infection to the peritoneal cavity, and the only guarantee for primary union of the abdominal wound.

In gunshot wounds of the pancreas we have no guiding symptoms upon which to base even a probable diagnosis. The wounds of entrance and exit of the ball, and its probable course, are the only facts which may point to the pancreas as one of the injured organs. In four out of five cases of gunshot wound of the pancreas the projectile penetrated posteriorly in the space between the angle of the left scapula and the angles of the ribs, and passed through the diaphragm and the solar plexus; in one the ball entered anteriorly near the tip of the xiphoid cartilage, and was believed to have passed through the stomach.

It is a somewhat significant fact that in all cases where life was prolonged for more than twelve days, the pancreas appeared to have undergone little or no pathological change in the vicinity of the visceral wound. Although the track of the ball did not in all cases remain aseptic, the inflammatory changes did not materially affect the parenchyma of the gland.

In a case of gunshot wound of the pancreas reported in the "Medical and Surgical History of the War of the Rebellion," Part II. vol. ii., the patient recovered from the immediate effects of the injury, death occurring from other causes a few weeks later. The post-mortem showed that the formation of a capsule around the bullet had already been initiated, and there is every reason to believe that if the patient had lived the foreign body would have become encysted in the parenchyma of the pancreas. Gunshot injuries of the pancreas, where they come under the observation of the surgeon as independent lesions, or as complications of other visceral injuries in cases of penetrating wounds of the abdomen treated by laparotomy, should be treated in the same way as a contusion or a laceration of the gland. The results obtained by the experiments have shown that if only a comparatively small portion of the pancreas remains in physiological connection with the duodenum, this portion of the gland retains its normal structure and its physiological function; and in all the experimental cases this was found adequate to supply the quantity of pancreatic juice necessary for the maintenance of normal digestion. While the surgeon may unhesitatingly remove the tail and a portion of the body of the pancreas without fear of any ill effects, either immediate or remote, great care must be exercised in operating in the vicinity of the head of the pancreas, to preserve the integrity of the common duct and as much of this portion of the organ as may appear compatible with the condition which necessitated the operation.

The results of my experiments, made with a view to ascertain how much of the mesentery of the duodenum can be detached without causing gangrene of the bowel, have been such as to encourage a conservative plan of treatment when operating in close proximity to the intestine. The observations made in this direction have shown that it is comparatively safe to detach a portion of the mesentery to the extent even of one to three inches, a procedure incomparably easier and much safer than enterectomy combined with partial excision of the head of the pancreas. I wish again to emphasize the fact

that complete extirpation of the head of the pancreas with the common duct is never justifiable, and that operations upon this portion of the gland for injury or disease must be limited to partial excision of the head, with preservation of the common duct.

#### ACUTE PANCREATITIS.

Acute idiopathic pancreatitis is an exceedingly rare affection: only a few well-authenticated cases of this disease have been reported, and none of the patients were children. The comparative immunity of the pancreas from disease is attributed by Gross to the singular structure of this organ, to its concealed situation, and to the absence of everything like a proper envelope. A brief consideration of this affection is necessary for the purpose of calling attention to a few of the most constant and prominent symptoms which characterize the disease, inasmuch as all suppurative lesions of the pancreas are preceded by acute or subacute inflammation. The disease either originates primarily in the inter-acinous connective tissue of the organ as a pancreatitis, or occurs as a secondary disease from an extension of a peri-pancreatitis to the substance of the gland.

Haller and Klob have given an accurate clinical description of a case observed at the Allgemeine Krankenhaus in Vienna, with a careful account of the post-mortem appearances. In one of the reported cases the symptoms were acute, and the disease terminated in death in the short space of sixteen days. The suppurative inflammation, beginning in the interstitial tissue, involved the entire gland, and extended by continuity to the para-pancreatic and peri-pancreatic tissue, giving rise to a diffuse and acute abscess. The termination in this case is sufficient evidence that the inflammation was produced by a specific cause,—infection with pus-microbes. In another case the primary seat of the inflammation was the same, but the process assumed a subacute course and terminated in a hyperplasia of the connective tissue. The most prominent symptoms in all the cases thus far reported were severe pain in the epigastrium, progressive anæmia, and obstinate vomiting. The pain was intermittent and neuralgic in character, and was referred to the region of the cœliac plexus, radiating from there over the abdomen. Neuralgia of the cœliac plexus is one of the most constant symptoms of disease of the pancreas: Klebs alludes to it as being present eleven times in fifteen uncomplicated cases. Atrophy of the cœliac plexus is mentioned by the same author as the cause of the neuralgia. All the patients suffering from acute pancreatitis presented an extremely anæmic appearance, and it is stated that one of them resembled a person who had suffered from repeated and severe hemorrhages. As the pancreas is not concerned directly in the function of hæmatogenesis, we can explain the constancy with which this symptom is present only by assuming that the anæmia was due to impaired digestion and assimilation, caused by arrest of the physiological function in the inflamed organ. In the reported cases no mention is made of the character of the stools. The presence of



undigested fat in the stools is, however, one of the rare symptoms of other affections of the pancreas, and consequently it must be present at least in some of the cases of acute inflammation of this organ when the secretion of the pancreatic juice is arrested by the inflammatory process. Klebs states that in three cases where this symptom was present the duct of Wirsung was either entirely or partially obliterated, while in a number of cases where the duct was in the same condition the stools remained normal.

Acute parenchymatous pancreatitis is frequently met with in children as a complication in cases of typhoid fever, pyæmia, septicæmia, yellow fever, and other acute infectious diseases. In this form of pancreatitis the organ appears red, swollen, and œdematous. Microscopically the most prominent lesion consists in swelling and undue granulation of the parenchyma-cells and in hyperæmia.

In non-suppurative pancreatitis the treatment should be commenced by the administration of small and frequently-repeated doses of calomel, followed by a saline cathartic, for the purpose of diminishing the hyperæmia and limiting the inflammatory exudation. Hot fomentations over the epigastric region will relieve the intensity of the pain, and at the same time will influence favorably the absorption of the inflammatory product. The diet must be carefully regulated and only such food allowed as can be digested and absorbed without the action of pancreatic juice. The employment of artificial digestive ferments with the food, such as pancreatine and extractum pancreatis, should be continued until the function of the gland has been restored. If the general and local symptoms point to sup-puration within or around the organ, the same prompt surgical measures must be adopted as are described under treatment of pancreatic abscess.

#### CHRONIC INTERSTITIAL PANCREATITIS, OR SCLEROSIS OF THE PANCREAS.

This lesion consists in an increase of interstitial connective tissue, which may affect the entire organ or remain limited to some particular portion, more especially the head of the gland. During the early stages of the disease the organ is enlarged, more vascular, and firm, while later the cicatricial contraction of the interstitial deposit produces atrophy of the parenchyma, with a corresponding diminution in the size of the organ. This form of inflammation of the pancreas is of particular interest to the surgeon, as the cicatricial contraction may produce secondary changes in the pancreatic duct or bile-ducts, an occurrence which would indicate a resort to surgical measures for the relief of immediate symptoms due to retention of the secretions.

The causes which produce sclerosis are often obscure, but usually are referable to some antecedent affection in some of the organs adjacent to the pancreas, as the peritoneum, subperitoneal tissue, duodenum, or common bile-duct, or to pancreatic lithiasis, in which case the primary cause is in the pancreas itself. The connective-tissue proliferation destroys the paren-

chyma by compression and constitutes one of the causes of stenosis of the pancreatic duct.

Todd observed this condition in a girl fourteen years of age, in whom the disease was situated in the head of the pancreas and the neighboring connective tissue. This case is of unusual interest, as the contraction of the cicatricial tissue produced obstruction of the common bile-duct by compression, which caused a dilatation of the bile-ducts behind the seat of obstruction, converting them into a large sac, which was located behind the duodenum and reached downward as far as the sacrum and laterally from one kidney to the other.

The medical treatment of chronic interstitial pancreatitis must be purely symptomatic. Indications must be met as they appear, and the diet selected with a view of taxing pancreatic digestion as little as possible.

The surgical treatment of sclerosis of the pancreas can apply only to secondary lesions which result from stenosis of the pancreatic duct or bile-ducts and to distention of these passages by accumulation of the secretions. Such an occurrence is most apt to take place when the disease affects the head of the pancreas, as the cicatricial contraction in this locality may cause stenosis of either the duct of Wirsung or the common bile-duct, or of both. Any operative interference in these cases will of necessity be limited to an attempt to secure an artificial outlet to the retained secretion. The restoration of the permeability of the natural outlet by any method of treatment is entirely out of the question.

The tendency of the disease is to aggravate the obstruction as cicatricial contraction progresses. The history of all these cases pointed to an impairment of digestion as the principal clinical feature in each instance. It is, therefore, of considerable importance to examine carefully into every obstinate and obscure case of indigestion, with a view to eliminate the possibility of organic disease of the pancreas as the cause of the derangement of digestion. In cases of permanent retention of the bile or the pancreatic juice caused by cicatricial compression of the bile-duct or the pancreatic duct, the earlier symptoms will have reference to a history of obstinate indigestion progressive in its character. If, on the other hand, the obstruction is produced by the impaction of a calculus, the previous history points to attacks of sudden and severe pain and other symptoms indicative of the passage of a calculus along the excretory duct.

In a case of biliary retention-cyst like that cited above, the establishment of an external biliary fistula would result in a permanent fistula, as the impermeability of the bile-duct would preclude the possibility of re-establishing the normal communication between the dilated bile-passages and the intestine. Such an operation would remove only the urgent symptoms due to retention and absorption of bile, but would leave unchanged the primary cause of the retention and would permanently exclude the bile as a digestive fluid from the alimentary canal. As the obstruction is permanent and irremediable, the operation which suggests itself as fulfilling

the urgent indications, as well as preventing remote ill consequences, is the formation of a new outlet for the bile into the intestinal canal, by establishing a permanent fistula between the duodenum and the gall-bladder, or between the duodenum and the dilated bile-duets. Duodeno-cholecystotomy has a future in all cases of permanent and incurable obstructive lesions in the bile-duct, and will become an established operation as soon as it has been perfected by an improved technique.

My experiments on animals have demonstrated that physiological detachment of any portion of the pancreas is invariably followed by degeneration and atrophy, irrespective of the particular method by which this detachment is effected; consequently, it is only reasonable to assume that permanent obliteration of the pancreatic duct by cicatricial contraction is always followed by degeneration of the parenchyma of the gland on the distal side of the seat of obstruction.

It is on this account that stenosis of the pancreatic duct is seldom followed by dilatation of the ducts to any considerable extent on the distal side of the constriction, and even more seldom by the formation of a cyst. A retention-cyst can result from obstruction only so long as secretion has not been entirely suspended, and when at the same time absorption of the pancreatic juice does not take place on account of further extensive pathological changes in the structures which perform this function when the gland is otherwise in a normal condition.

As the physiological detachment by obstruction of the common pancreatic duct caused by cicatricial contraction is invariably followed by complete destruction of the parenchyma of the contributory portion of the gland, it is evident that the surgical treatment of a cyst of the pancreas in such cases can be indicated only when the swelling becomes in itself a source of serious inconvenience and pain. The proper treatment in all such cases consists in the formation of an external pancreatic fistula by abdominal section. There is no danger, in such instances, of the fistula remaining permanent, as the glandular tissue which might remain at the time of operation will, in the course of time, disappear by degeneration and absorption. As in animals, so in man, the health of the individual after gradual atrophy of the pancreas will depend upon the physiological capacity of vicarious organs, in each particular case, to assume the functions of the pancreas.

In recapitulation, it may be stated that cirrhosis or chronic interstitial pancreatitis sometimes produces stenosis of the bile-duct or of the pancreatic duct, and that when the obstruction is followed by retention of the secretions an operation becomes always necessary in biliary retention, which should be treated by establishing a new outlet for the bile into the duodenum, while the formation of an external pancreatic fistula in cases of cyst of the pancreas becomes necessary only when the presence of the swelling in itself has become a source of sufficient pain and discomfort to warrant treatment by abdominal section.

## GANGRENE OF THE PANCREAS.

One of the terminations of acute inflammation of the pancreas is gangrene. Cases have been reported where spontaneous recovery followed elimination of the necrosed organ through the alimentary canal. If spontaneous recovery in this condition is possible, it would seem plausible that a timely removal of the necrosed organ by surgical interference would add to the chances of recovery; consequently we include gangrene among the diseases of the pancreas which should be treated by operative measures.

The pancreas may constitute one of the component parts of the intussusceptum in cases of invagination of the bowels. Such a case has been reported by Baudl, and the specimen examined by Rokitsansky furnishes a similar illustration. A case reported by Chiari may have been of a similar nature, the invaginated portion having sloughed with the remaining portion of the intussusceptum, leaving the continuity of the bowel unimpaired by adhesions at the point of separation. If in this instance the necrosis was due to inflammation, we can only infer that the para-pancreatic abscess ruptured into the bowel, that the necrosed portion of the pancreas was eliminated in this manner, and that subsequently the opening in the bowel was closed. Constipation was a prominent symptom in a number of these cases, and in Rosenbach's case the symptoms of obstruction were so well marked that it was decided to perform laparotomy for its relief. This last case is also of great interest, as during life the existence of a tumor in the region of the pancreas was diagnosed.

Modern surgery deals extensively with abdominal section for the relief and cure of peritonitis and intestinal obstruction. In searching for the cause of either of these conditions during laparotomy, the pancreas should not be forgotten, and when it is found that the primary disease is located in or around this organ, radical measures should be adopted whenever they are practicable.

Whenever the sac can be stitched to the external incision this should be done, and the sac opened, disinfected, and drained. Search should be made for the necrosed pancreas, and when found detached it should be removed. As in most of these cases the retro-peritoneal tissue is extensively infiltrated, a counter-opening should be made in the lumbar region above the kidney, and through drainage established. If an anterior abdominal fistula cannot be established, the course to be pursued should be the same as in treating a pancreatic abscess under similar conditions.

## ABSCESS OF THE PANCREAS.

At the present time no one familiar with the recent advances in surgery would question the propriety of treating a suppurating cavity by incision and drainage, wherever it might be located. Some of the most valuable recent contributions to surgical literature describe improved methods in treating deep-seated abscess. Asepsis and effective drainage are the two

cardinal points upon which we have learned to depend in the treatment of abscesses in important organs or cavities. If we can secure and maintain these two essential conditions, we can attack with immunity, and a fair hope of success, any abscess, wherever it may be located, and whatever its immediate surroundings may be.

In looking over the literature on abscesses of the abdominal organs, we find that modern surgery has been guided almost exclusively by the teaching of the old master: *Ubi pus, ibi evacuo*. It is somewhat surprising that abscess of the pancreas has never been made the subject of surgical treatment. The two principal reasons for this may be found in the facts that abscess of the pancreas is of rare occurrence, and that the recognition of the lesion, when it does exist, is surrounded by many difficulties. There can be no doubt, however, that in the near future abscess of the pancreas will be treated on the same principles as suppuration in any other locality.

The remote location of the abscess may offer many serious obstacles to diagnosis and a rational course of treatment, but these difficulties will be overcome by improved methods of examination and more perfect methods of operation. As suppuration is only one of the terminations of inflammation, abscess, like inflammation, may occur primarily in the gland itself, or it may commence in the para- or peri-pancreatic tissue. If the abscess is endo-pancreatic, it may be bounded and circumscribed by the proper investment of the gland; if, on the other hand, it commences primarily outside of the gland, it appears as a diffuse abscess, which extends to the pancreas by contiguity; in other words, we speak of the abscess as a suppurative pancreatitis, or a suppurative peri- or para-pancreatitis.

**Pathology of Abscess of the Pancreas.**—Recent investigations have shown the existence of a direct causative relation between the pus-microbes and suppuration: hence we must take it for granted that every purulent pancreatitis, peri-pancreatitis, or para-pancreatitis is caused by the presence of these germs in the tissues. In case there is no direct invasion by a loss of continuity of the hollow viscera in the vicinity of the pancreas, or no direct communication with the external air by a penetrating wound, we must assume that the germs reach the gland through the circulation and find a favorable soil prepared by some antecedent pathological change. Such conditions may be determined by contusion of the organ, disturbance of the capillary circulation by various causes, or thrombo-phlebitis. Norman Moore reports the case of a female, twenty-seven years of age, who died of pyo-phlebitis, and in whom, on post-mortem examination, besides the portal, splenic, and vena azygos minor veins, the pancreatic veins were blocked by decolorized and adherent thrombi.

In the "Pathological Society's Transactions" the same author gives an account of two cases of abscess of the pancreas due to plugging of the pancreatic vessels. On page 210 he remarks, "Pathologically, the case in which thrombosis of the pancreas was found is interesting as indicating how

pancreatic abscess is produced. The much commoner condition of the liver in the other cases shows that, had the first patient survived, the thrombosis would certainly have been followed by abscess. Clinically, the value of the case is that it may, in rare cases, help to explain the seat of an obscure abdominal swelling, associated with fever, which has followed a thrombosis, and which physical examination cannot localize in the liver."

Suppuration always begins in the interstitial tissue, either within the gland or in the connective tissue around it. A suppurative inflammation and formation of an abscess are different stages of the same process. Peri-pancreatic suppuration commences, in most instances, in the adjacent lymphatics, the pus surrounding the lymph-glands or forming a small abscess.

In the vicinity of the pancreas these peri-lymphatic abscesses are not unfrequently met with as one of the pathological conditions of pyæmia. Thus, an abscess in the pancreas with perforation into the peritoneal cavity was examined by Perle. Tulpius saw an abscess of the pancreas as a secondary lesion after an attack of malarial fever. Schmackpfeffer observed the same condition after an operation for strangulated hernia, and Portal after extirpation of a testicle. But suppuration in the pancreas sometimes takes place as an independent affection, without the presence of an appreciable infection-atrium, and in these cases we must assume that the essential and specific noxæ are carried along with the circulating blood, and that localization takes place upon a soil prepared for their reception and growth by previous alteration in texture or circulation. In some instances the process begins upon the outer surface of the gland, the pus separating the gland from its attachments. In the case described by Gendrin the pancreas appeared to have been completely detached, and was lying loose in the abscess-cavity.

Many of these para-pancreatic abscesses do not present well-defined borders; the pus manifests a tendency to burrow in the vicinity of the mesocolon and the retro-peritoneal space, and is apt to perforate into the bursa omentalis, or into some other portion of the peritoneal cavity, or, lastly, finds its way into one of the adjacent hollow organs, as the stomach or the intestinal tract.

Van Derveren reports the case of a female who had suffered for thirty years from attacks of gastralgia. At the necropsy it was ascertained that the indurated pancreas had perforated the posterior wall of the stomach. The opening represented a round ulcer, two and a half inches in diameter, with indurated margins. In this aperture eroded vessels could be seen. The fistulous tract communicated with the pancreatic duct. The stomach and intestines contained blood, but no other evidences of disease could be found. In Percival's case the abscess ruptured into the bowel, the stools containing fetid pus and blood. A similar case was observed by Haggarth.

The suppurative process, however, may extend in an opposite direction, from the stomach to the pancreas. A communication between the stomach and the pancreas is sometimes established by perforation of a gastric ulcer

in this direction. Around the margins of the ulcer, between the stomach and the pancreas, adhesions are formed, an occurrence which prevents extravasation of the contents of the stomach into the peritoneal cavity. A number of the terminal openings of the pancreatic ducts have been observed upon the cicatrized surface of a gastric ulcer. In place of the formation of a permanent pancreatico-gastric fistula as described by Rokitsansky, perforation of the stomach in closer proximity to the pancreas may give rise to diffuse and rapidly-fatal para-pancreatitis or peri-pancreatitis.

The indirect primary cause of a pancreatic abscess may be the presence of a calculus in the pancreatic duct. Fournier has recorded a case where, on post-mortem examination, an enormous abscess was found in the head of the pancreas, which contained numerous calculi. The tumor was sufficiently large to be readily detected in the epigastric region during life.

An abscess of the pancreas may also originate in a pre-existing cyst of the organ. Kilgour's case had undoubtedly such an origin. The abscess-cavity was as large as a teacup, and contained a milky fluid and caseous particles, which were undoubtedly a mixture of pus and pancreatic juice. The disease was attended by chills and fever, which indicated that the retention-cyst had become the seat of an acute suppurative inflammation.

As primary, idiopathic, uncomplicated, purulent inflammation of the pancreas is an exceedingly rare affection, it is of great practical importance in the surgical treatment of such cases to determine, if possible, the predisposing cause or causes, and to remove them, or render them inert, at the time of operation.

**Symptoms and Diagnosis.**—The presence of pus within the pancreas or in its immediate vicinity is not indicated by any characteristic or positive symptoms. The symptoms always point to the stomach or liver as the seat of the disease. The most prominent and constant symptoms which have been observed are nausea, vomiting of a clear greenish or viscid fluid, thirst, loss of appetite, constipation, progressive emaciation, and distention of the epigastrium.

In almost all cases the patients presented a sallow, cachectic appearance, and were exceedingly anæmic. Ascites and œdema of the lower extremities were present a number of times. In several instances the inflammatory process in the pancreas extended to the bile-duct, or caused stenosis of the duct by compression, conditions which are followed by biliary retention, a symptom which has usually been interpreted as an evidence of primary disease of the liver or bile-ducts. The progressive anæmia and emaciation, in the absence of other tangible lesions, are symptoms which always should direct attention to the pancreas as the seat of the disease.

Fever was seldom a conspicuous and never a constant symptom of suppurative pancreatitis. The use of the thermometer in the diagnosis of suppuration in this locality is important, but it furnishes no positive evidence. If the abscess is large, it will be recognized by palpation and deep percussion as a tumor in the epigastric region. In such cases a probable

diagnosis may be made by a careful and systematic physical examination and reasoning by exclusion.

An abscess within the gland is always located in the bursa omentalis; a peri-pancreatic abscess, in the bursa omentalis, duodeno-jejunal fossa, or upper portion of the peritoneal cavity; and a para-pancreatic abscess, in the retro-peritoneal space. Inflammation of the stomach will often serve a useful purpose in the differential diagnosis of tumors in the epigastric region. In obscure cases, manual exploration of the rectum may add important and sometimes decisive information.

Age is also an important element to be considered in the diagnosis. Most of the cases of abscess of the pancreas were patients over forty years of age, and often persons of intemperate habits. Puncture with an aseptic capillary needle will demonstrate the presence or the absence of pus, but will not add material information in locating with accuracy the abscess-cavity.

Finally, in all cases where a tumor can be felt in the epigastric region, and a probable diagnosis can be made regarding its benign character, an exploratory laparotomy should be resorted to for the purpose of making an accurate anatomical diagnosis.

**Prognosis.**—The prognosis of abscess of the pancreas is always unfavorable. Death is produced by progressive emaciation and inanition, by septic absorption, or by secondary lesions in adjacent organs. In acute diffuse pancreatic abscess a fatal termination may take place in a few days. One of the great dangers of abscess in this locality is the close proximity of numerous important veins, which become implicated by extension of the suppurative inflammation to their walls, producing a suppurative thrombophlebitis, with all its disastrous consequences. Perforation of the abscess into the stomach or the intestinal tract is the most favorable spontaneous termination, and has resulted at least in one instance in a cure. Perforation of the abscess into the peritoneal cavity would hasten death by inducing a rapidly-fatal septic peritonitis.

**Treatment.**—The remarkable success which has attended the treatment of pelvic and abdominal abscesses by laparotomy justifies the hope that in the near future the same treatment will be extended to abscess of the pancreas. It is true that the difficulties which surround the treatment of abscesses in this region are many, but they are not insurmountable. Multiple abscesses disseminated through the entire organ, and especially in its head, are not amenable to successful surgical treatment. Circumscribed endo-pancreatic abscess in the peripheral portion of the body or tail of the pancreas should be treated by partial excision of the pancreas in all cases where the isolation of that portion of the organ can be accomplished without inflicting serious injury upon adjacent important organs. When extirpation is impossible, as when the abscess is located in the head of the pancreas, it must be treated by incision and drainage. This is accomplished in the same manner as in the treatment of a pancreatic cyst. In some instances the



access to the abscess is rendered difficult by distention of the stomach, the dilated organ overlapping the pancreas. In such cases the stomach must be pushed upward, and subsequent distention guarded against by ordering an absolute diet until the external fistula has been established. The external incision must in all cases correspond to the most prominent part of the swelling, as it is of the greatest importance to incise the abscess at a point where the distance between the surface of the abscess and the abdominal wall is the shortest. Incision of the great omentum will be required in all instances.

In making an external fistula in the treatment of a pancreatic abscess it is essential to protect the muscular and connective tissues of the external incision against contact with pus by lining the margins of the wound with the parietal peritoneum before the serous covering of the anterior wall of the abscess is stitched to the margins of the wound. One of the greatest difficulties that will be encountered in this operation will be the approximation of the peritoneal surface of the abscess with the margins of the wound, on account of the distance between the surface of the abscess and the anterior abdominal wall: this difficulty will decrease in proportion to the prominence of the swelling.

The size of the external incision will exert an important influence in this direction. If the incision is large, the margins of the wound can be turned inward, thus facilitating the suturing of the anterior wall of the abscess to the margins of the wound. As a rule, it may be relied upon that the anterior wall of the abscess, covered by peritoneum, is quite thick, so that there is little danger of penetrating the abscess-cavity with the needle in suturing. Previous evacuation of the abscess-cavity by aspiration would diminish the danger of extravasation of pus through the needle-punctures, but would also render approximation difficult by the recession of the abscess-wall, and should, therefore, not be resorted to unless the swelling is sufficiently prominent to render this circumstance of little importance.

As the suturing of the two peritoneal surfaces is done for the purpose, in the first place, of preventing extravasation of pus into the peritoneal cavity, and, secondly, of securing permanent adhesions between the abscess-wall and the margins of the wound, it is important to apply the sutures closely together and to grasp the tissues in such a manner that tearing through of the sutures is impossible. As considerable tension may follow, it would be advisable, in this particular instance, to use silk sutures. As in these cases time is an important element, incision and drainage should follow suturing immediately.

The remaining steps of the operation will depend upon circumstances. If the abscess is endo-pancreatic or peri-pancreatic, simple incision, drainage, and disinfection will answer all indications. If, however, the purulent cavity is located behind the peritoneum and occupies the connective-tissue space behind the pancreas, it would appear rational to drain the abscess posteriorly through one of the lumbar regions above the kidney by push-

ing a long closed forceps in a proper direction through the posterior and lateral wall of the abscess until its point can be felt under the skin externally. A small cut in the skin over its point will enable the operator to push the instrument clear through, and, by dilating its blades, widen the canal sufficiently to permit the insertion of a large drainage-tube. In this manner the most desirable method of drainage—through drainage—could be established, which would render subsequent disinfection and evacuation of the abscess a comparatively easy task. In cases where an anterior pancreatic fistula cannot be established, on account of the distance between the abscess and the anterior abdominal wall, we might resort to lumbar drainage, and closure of the incision in the anterior wall of the abscess by carefully inverting and approximating the peritoneum over the wound with fine silk sutures.

That the utmost care in the application of antiseptic precautions should be resorted to in the evacuation of pus in this remote region by any of these procedures requires no argument. I will repeat that a positive diagnosis of the presence and precise location of a pancreatic abscess is possible only by resorting to explorative laparotomy, and that this diagnostical aid should always be resorted to when the history of the case and the symptoms and signs presented are sufficiently suggestive to point to a probable diagnosis.

The abscess found and located by abdominal section should be removed by partial extirpation of the pancreas when it is endo-pancreatic and located near the splenic end of the pancreas. When extirpation is impossible, or when the abscess is located in the head or on the anterior surface of the pancreas, it should be treated by the formation of an anterior abdominal fistula; when located behind the pancreas, by through drainage, or by lumbar drainage performed through the abdominal cavity.

#### CYSTS OF THE PANCREAS.

During the last few years eighteen cases of cyst of the pancreas have been reported, and, as most of the patients recovered under proper surgical treatment, the treatment of such cases by abdominal section has become an established operation. The youngest of the patients so far reported was a girl sixteen years of age, but there is no reason why this affection should not occasionally develop during childhood as the result of injury, or following in the course of lesions in the pancreas which cause obstruction and at the same time suspend auto-absorption of the retained secretion.

In my experiments upon the pancreas in animals it became apparent that simple obstruction never causes the formation of a cyst, but that the most important factor which determines cystic disease in the pancreas is an alteration of its tissues which suspends the absorption of pancreatic juice behind the seat of obstruction.

The case referred to is reported by Kramer; the operation was performed by Hahn. Female, sixteen years of age, after an attack of vomiting and pain in the abdomen, noticed a gradual distention of the upper portion of the abdominal cavity. The size of the tumor

and area of dulness corresponding were about the same as in my case. The dulness appeared to be continuous with the hepatic dulness. Echinococcus cyst of the liver was diagnosed. Laparotomy was performed, and the omentum divided between the stomach and the transverse colon. About two litres of an albuminous fluid were removed by tapping. The cyst was stitched to the margin of the abdominal wound, incised, and drained. The patient recovered, with an external pancreatic fistula, which continued to secrete pancreatic juice for four months.

**Etiology.**—The causes which result in the formation of small cysts of the pancreas, or cysts which result from compression by tumors, which in themselves do not admit of an operation for their removal, and at the same time constitute a source of danger to life, do not come within the scope of this paper. In the latter instance the cyst is simply a sequence of the primary cause, and as such it will seldom, if ever, become the sole or direct object of surgical treatment. The causes of retention-cysts amenable to operative treatment are such as do not in themselves imperil the life of the patient. They may be classified as follows: 1. Obstruction to the outflow of the secretion from impaction of calculi in the common duct or its branches. 2. Partial or complete obliteration of a portion of the duct from cicatricial contraction. 3. Sudden or gradual obstruction of the duct, without diminution of its lumen, from displacements of the pancreas.

1. *Calculi.*—The impaction of the pancreatic duct at its outlet may be caused by the presence of a biliary calculus in the ductus communis choledochus, at the junction of the former with the latter. A case of this kind has been reported by Engel. In such cases the obstruction gives rise to retention of the secretions from the liver and the pancreas, and dilatation of the excretory ducts in both organs. Calculous concretions in the pancreatic ducts have been frequently observed to give rise to retention-cysts. Johnston has collected thirty-five cases in which, upon post-mortem examination, stony concretions were found in the pancreas. Incrustations are not so frequent as free concretions. Gendrin has described a pancreatic cyst where the normal pancreatic secretion was converted into a fatty, chalky pap. The causes which produce a concretion in the pancreatic duct are chemical changes in the secretion itself, or an obstruction to its free exit by inflammatory changes in or around the common duct. The degree of dilatation, other things being equal, is in direct proportion to the completeness of the obstruction to the outflow of the secretion. It may be well to allude to the possibility that in some instances a pancreatic calculus may remain stationary for an indefinite period of time in the duct, giving rise to no symptoms and causing only partial obstruction, until, by the action of some determining cause, it is forced into a position where it effects complete mechanical obstruction to the outflow of the fluid, and a rapid increase in the size of the cyst. As an impacted biliary calculus may give rise to pancreatic obstruction, so a pancreatic calculus, when it is impacted at a point where compression of the common bile-duct can take place, will produce icterus and dilatation of the gall-bladder and bile-ducts. Meckel has reported such a case.

Among the specimens of pancreatic cysts so far examined which were caused by concretions, none had attained the size of those which have been submitted to surgical treatment. As in most of these preparations the calculi did not completely fill the calibre of the duct, they caused only partial obstruction, which would furnish an explanation of the slow growth and comparatively small size of the tumor. In the specimen described by Gould it appears that the common duct was completely closed by two calculous concretions at its entrance into a chalky deposit four to eight inches in length and of a yellowish color. The duct of Wirsung was dilated to such an extent as to form a large cyst, which occupied the whole length of the pancreas, its walls being inseparable from the substance of the gland. In this case the interstitial inflammation was more extensive and the cyst was much larger. In the cases reported by Pepper and Hjett the obstruction was due to the same cause. In Curnow's case the common duct had become obliterated at its entrance into the duodenum by catarrhal inflammation. The pancreas was atrophic, and its duct was filled with numerous calculi. The pancreatic juice had become inspissated. The cystic duct of the gall-bladder was impermeable, while in the common bile-duct a number of small gall-stones were found.

2. *Cicatricial Contraction*.—I have failed to find in the literature any allusion to stricture of the duct, resulting from traumatism. In the case that came under my own observation the patient was nineteen years of age, and the cause was clearly traceable to an injury which he had sustained a few weeks before the cyst became apparent in the epigastric region.

The pancreas is an exceedingly slender organ, of loose and somewhat friable texture, and hence, although remotely located and well protected by surrounding organs, I am of the opinion that it is the seat of injury more frequently than has been generally supposed. If the stomach is empty and the abdominal muscles relaxed, a blow over the region of the pancreas may result in serious contusion or laceration of the organ without rupture of its envelope. Again, a well-directed blow over either extremity of the gland may cause a laceration of its tissues by traction, the organ being securely fixed in its place by firm connective-tissue attachments. The clinical history of several cases of rapidly-growing cysts tends to prove that obstruction occurred in this manner. If the duct escapes injury, the cicatricial contraction attending and following the reparative process in the lacerated gland-tissue will gradually compress the duct, or by lateral traction change its direction and thus impede the outflow of the secretion. If the duct is ruptured at the time of injury, its lumen may become completely filled by a thrombus which renders it impermeable, giving rise to retention and extravasation of the secretion primarily, and secondarily to definitive occlusion of the duct by cicatricial contraction at the point of injury. I am quite convinced that in the case which I have reported the retention was the direct result of traumatic stricture of the common duct. Although this view is not supported by evidence from post-mortem examinations, it is

confirmed by analogous production of cysts in other locations. It is evident that this class of cases would furnish the most favorable conditions for successful surgical treatment.

3. *Obstruction from Displacement of the Pancreas.*—As the pancreas is retained in its normal transverse position by the surrounding organs and connective-tissue attachments, a relative change of position of portions of the gland would result in a bending of the organ and obstruction in the duct at the point of flexion. This condition was the cause of retention in a case related by Engel, who in a woman sixty years of age found that the tail of the pancreas formed with the principal duct of the gland a right angle upward. A dislocation of this kind can occur in one of the following ways:

1. Through abnormal relaxation of the connective-tissue attachments of the gland, permitting a portion of the organ to descend by its own weight lower in the abdominal cavity.

2. From pressure upon the gland by tumors or exudations.

3. From cicatricial contractions in the substance of the organ or in the peri-pancreatic space.

That the whole pancreas can become displaced is proved by the case reported by Dobrzycki. A man fifty years of age fell a distance of some yards; after the fall symptoms arose similar to those of a floating kidney. By palpation the displaced organ could be located. Saline fluid resembling pancreatic juice was vomited. In the hypogastrium a movable tumor corresponding in position and shape to the pancreas could be felt.

**Diagnosis.**—The question of diagnosis can be entertained only in cases where the cyst has attained very considerable proportions. The most important points to be taken into consideration are the history of the case, the anatomical location of the tumor, and its relations to the surrounding organs. The cases which have been reported have occurred exclusively in adults. Sex appears to exert no determining influence. In a number of cases the clinical history refers distinctly and forcibly to traumatism as the exciting cause. In Gussenbauer's case the beginning of the illness was traced to indiscreet eating and drinking.

In all instances of cystic tumors in the region of the pancreas, close inquiry should be made to ascertain the existence of antecedent inflammatory affections of the organ or in its immediate vicinity. A history pointing towards the existence of a biliary or a pancreatic calculus will also prove valuable in arriving at positive conclusions. Rapid growth of the tumor speaks in favor of its pancreatic origin. In Gussenbauer's, Kulenkampf's, and my own cases the tumor attained an enormous size within a few weeks. Considering the relations of these cysts to important surrounding organs, it is remarkable that they give rise to no serious symptoms aside from the pressure they exert upon adjacent organs. Pain is not a constant symptom, and when it is present it is due more to the causes which produce the cyst than to the cyst itself. In this respect cysts of the pancreas form a coun-

terpart to malignant disease when it affects this or neighboring organs. Emaciation is due either to coexisting affection of the gland, or to the impairment of function of important organs by pressure of the cyst. It is never so marked in these cases as in malignant disease. The supervention of fatty stools would point towards the existence of some coexisting serious lesion of the pancreas rather than towards the existence of a simple cyst of the organ. This symptom was not found present, or was overlooked, in all cases which have been operated upon. Of twenty-eight cases of stearrhœa which were compiled by Ancelet, sixteen were examined post mortem. In five of these there was occlusion of the ductus choledochus and ductus pancreaticus; in three, occlusion of the pancreatic duct alone; in one, inflammation of the pancreas and some of the adjacent organs. In the remaining cases disease of the liver and the bowels, or marasmus only, was found. In thirteen cases of pancreatic calculi collected by Johnston, in three only were fatty stools observed; in six cases, diarrhœa; in four cases, melœna; and in six cases, constipation. The presence of fat in the stools is a symptom of great importance in the recognition of pancreatic disease, but that it is not of absolute diagnostic significance is proved by the well-known fact that the same condition will follow upon the obstruction of the biliary passages and upon affections which impair the functional activity of other organs of digestion.

Obstruction of the principal duct impairs digestion more than when its distal extremity or one of the accessory ducts is involved. The actual illness of the patient is usually preceded for a variable length of time by more or less marked symptoms of gastro-intestinal derangement, accompanied in some instances by pain in the region of the pancreas.

A peculiar color of the skin, which by some is believed to be characteristic of pancreatic disease, must be mentioned, as it was observed in several cases of calculous affection and cysts of the pancreas. The appearance presented by these patients is variably described as being unhealthy, pale yellow, dirty, or earthy. The intimate relations of the cyst to the cœliac plexus will explain the cause of cœliac neuralgia which is met with in some of these cases. Atrophy of the cœliac plexus from long-continued pressure may give rise to mellituria, for the same reason that Klebs has affirmed that partial extirpation or atrophy of the cœliac plexus will cause the presence of sugar in the urine. Diverse diseases of the pancreas have also been known to produce diabetes mellitus. Cases of this kind have been reported by Cowley (1788), Bright, Elliotson, Frerichs, Fles, Hartsen, Silver, Recklinghausen, Munk, Seegen, and Friedreich. Klebs demonstrated by his experiments that complete extirpation of the pancreas or ligature of its duct invariably gave negative results, as far as diabetes was concerned, and this may account for the fact that no sugar was found in the urine of the cases reported in this paper. The cyst, when examined early, before it has attained considerable size, is always found in the region normally occupied by the pancreas. The exact location, however, is not always

uniform, as it will depend upon the portion of the pancreas from which the cyst has taken its primary origin. It may be situated below the right lobe of the liver, as in Kulenkampff's case; in the epigastric region, as in Gussenbauer's case; or in the left hypochondrium, as in my case. When the tumor has attained a large size, or occupies the whole abdominal cavity, it will be difficult, and in the latter instance impossible, to determine by any known means its primary origin. In such cases it is of paramount importance to study its relations to adjacent organs. The tumor is invariably situated in the bur a omentalis, and from this point, as it increases in size, it encroaches upon the space occupied by adjacent organs. The stomach is pushed forward in all cases, and later to the right. The transverse colon is displaced downward, the spleen to the left, and the diaphragm and contents of the chest upward. The cyst being in direct contact with the diaphragm, it usually ascends and descends with the respiratory movements of the chest.

In doubtful cases it will become necessary to inflate the stomach and colon, with a view to ascertain their position relative to the cyst. If the patient is a female, and the tumor occupies the entire abdominal cavity, it will simulate cystic disease of the ovary so closely that a differential diagnosis between the two is impossible. The cases reported by Luecke, Bozeman, and Rokitansky furnish adequate proof of the correctness of this statement. The proximity of the abdominal aorta is such that the impulse of the artery is imparted to the tumor, which, however, pulsates only in one direction,—away from the artery,—a fact which will always distinguish it from an aneurism. Unless the cyst is exceedingly tense, a sense of fluctuation is always imparted by palpation. Palpation is rendered difficult on account of the deep location of the pancreas and the rigidity of the recti abdominis muscles. The normal pancreas can be felt only under certain favorable conditions. Concerning this point Sir William Jenner says, "By deeply depressing the abdominal walls about a hand's breadth below the umbilicus, and then rolling the subjacent parts under the hand (the stomach and colon must be empty), it might be possible to detect it in an individual who is thin and whose tissues are lax." In case the examination is rendered difficult on account of great rigidity of the abdominal muscles, this obstacle can be overcome by examining the patient while under the influence of an anæsthetic. An exploratory puncture with a fine and perfectly aseptic needle of a hypodermic syringe will not only add material diagnostic information by revealing the character of the cyst-contents, but will also settle the question as to the existence or absence of adhesions between the cyst-walls and the parietal peritoneum. In the differential diagnosis the following affections will come up for consideration :

1. Malignant disease of the pancreas or adjacent organs.
2. Aneurism.
3. Echinococcus of the liver, the spleen, or the peritoneum.
4. Affections of the retro-peritoneal lymphatic glands.

5. Hydro-nephrosis or pyo-nephrosis.
6. Cystic disease of the suprarenal capsule.
7. Circumscribed peritonitis, with exudation.
8. Ascites.
9. Cystic disease of the ovary.

**Prognosis.**—Physiologists are agreed in assigning to the pancreas a most important function in the digestion of organic food. We know that by a special ferment it assists in the transformation of starch into dextrin and sugar and in the digestion of albumen and fat. We should naturally expect that in diseases of this organ the digestion of these substances would be impaired in proportion to the amount of gland-tissue destroyed. On the other hand, we have abundant evidence to show that even total disorganization or destruction of the pancreas is not incompatible with normal digestion and perfect health. It would appear that in the absence of the pancreatic secretion other organs assume a vicarious action and digestion proceeds unimpaired. It is also important to remember that even a large cyst of the pancreas does not necessarily result in extensive destruction of the gland, and that the remaining gland-tissue continues to secrete and discharge a sufficient amount of pancreatic juice. In Bozeman's case the cyst occupied the entire abdominal cavity, and yet at the operation the greater portion of the gland was found healthy in structure. The integrity of the structure and function of the gland depends less on the pressure of the cyst than on the causes concerned in its production.

The dangers arising from the cyst itself consist in (1) its interference with the functions of other abdominal organs by pressure, and (2) rupture of the cyst and escape of its contents into adjacent hollow organs or the peritoneal cavity. Compression of the stomach and interference with its normal peristaltic action constantly occur when the cyst has developed to any considerable size. When such is the case, vomiting soon after meals takes place, as was noted in a number of cases which have been reported. When the cyst is of very large size, nearly all the abdominal organs suffer by compression, and both digestion and absorption are impaired by mechanical pressure. The diaphragm being at the same time pushed upward, the heart and lungs are displaced in the same direction, and embarrassment of circulation and respiration follows as a necessary consequence. Like any other benign abdominal tumor, the cyst proves dangerous to life by interfering mechanically with the functions of more essential and important organs.

The second source of danger is rupture of the cyst and escape of its contents into adjacent organs, an accident which may be followed by immediate death from hemorrhage, or will place the life of the patient in jeopardy by suppurative inflammation in the interior of the cyst, or by peritonitis in case the contents have escaped into the peritoneal cavity. In Pepper's case the immediate cause of death was hemorrhage consequent upon rupture of the cyst into the stomach. At the post-mortem examination a large quantity of blood was found in the stomach and intestine,



which had entered through an opening about half an inch in diameter, close to the proximal termination of the ductus communis. A probe passed through this opening directly entered a cyst in the head of the pancreas. A communication with any portion of the gastro-intestinal tract would almost of necessity cause infection and suppurative inflammation in the interior of the cyst, which, under unfavorable circumstances, might lead to a fatal termination from septicæmia or extension of inflammation to adjacent organs.

The prognosis may be said to depend—

1. On the nature and cause of the obstruction.
2. On the size of the cyst.
3. On the absence or presence of complications.

**Treatment.**—In the treatment of a pancreatic cyst the indications are the same as in the treatment of any other kind of cyst,—viz., (1) extirpation of the cyst, (2) evacuation of the cyst-contents and obliteration of the cyst.

Extirpation was attempted in Bozeman's and Rokitansky's cases; in the former instance success was complete, in the latter the operation was not completed, and the patient died a few days afterwards, of septic peritonitis. It is proper to state that in both cases the operation was done for the removal of a supposed ovarian cyst, and that a correct diagnosis was made in the first case during the operation, after the pedicle was traced to the pancreas and the intact portions of the gland were identified; in the second case the post-mortem examination revealed the true nature and location of the cyst. The brilliant result obtained by Dr. Bozeman is well calculated to stimulate others to follow his example. Extirpation of the cyst would guard most effectually against the formation of a permanent pancreatic fistula, but, on account of the deep location of the pancreas, the shortness or absence of a pedicle, and the many obstacles thrown in the way of the operator by adjacent organs, the procedure is surrounded by innumerable difficulties, and, in the present state of our science, is of doubtful propriety. Simple evacuation of the cyst-contents by means of the aspirator presents two principal objections against its adoption in the treatment of cysts of the pancreas:

1. Escape of cyst-contents into the peritoneal cavity.
2. Reaccumulation of secretion.

Reasoning from analogy, we should naturally expect that when pancreatic juice is brought in contact with the peritoneum it would produce a destructive effect thereupon by its digestive properties, or that such contact might even be followed by diffuse peritonitis. In opposition to this assumption, it is affirmed that in experiments on the pancreas the pancreatic juice frequently escapes into the abdominal cavity from the canula introduced into the pancreatic duct, without any bad results on the animals. Concerning this point Heidenhain says, "The animals do not suffer from this circumstance, as the duct is regenerated in spite of the wounded surface being

bathed in the secretion. Nevertheless, it is difficult to explain this. Why do not the wounded and suppurating tissues undergo digestion by the pancreatic juice? The efficacy of the albumen ferment is destroyed in some way, I presume, probably by being changed into zymogen, the living tissues having the same effect on the juice as Podolinski observed by treating the pancreatic juice with pulverized zinc or yeast ferment." Although small quantities of pancreatic juice may escape into the peritoneal cavity of an animal without any serious consequences, we have no evidence to show that the peritoneal cavity in man is possessed of the same immunity against such accident, and it would not be prudent to expose the patient to such risk until more light is thrown on this subject by further observation and experiment. At the same time we must not forget that pure pancreatic juice is found only in small cysts, as the contents of large cysts have undergone various transformations, and are mixed with different accidental products, which might prove an additional source of danger in producing peritonitis. In all the cysts where a pancreatic fistula was established, the artificial opening continued to discharge the secretion for a variable period of time, and in two cases the discharge had not ceased at the time the report was made, and hence reaccumulation would have been inevitable in case the fluid had been removed by aspiration. For these reasons, the treatment by aspiration should be limited to cysts of moderate size, and where adhesions have formed between the cyst and the anterior walls of the abdomen. In cases presenting these favorable conditions, aspiration deserves a trial, and may be repeated as often as required, or until symptoms arise which call for more radical measures. The needle should always be thoroughly disinfected by passing it through the flame of a spirit-lamp and by dipping it in a five-per-cent. solution of carbolic acid. The puncture is made obliquely, so as to prevent the formation of a fistulous opening. The fluid should be withdrawn slowly and the cyst emptied as completely as possible.

After the operation gentle pressure should be made over the cyst, by applying a compress and elastic bandage. The safest and at the same time the most efficient treatment consists in establishing a pancreatic fistula. The operation which accomplishes this purpose most safely and in the shortest time consists in exposing the cyst by an incision and stitching its walls to the margins of the wound. The same aseptic precautions must be observed before, during, and after the operation as in any other abdominal operation. The stomach being generally pushed forward, upward, and towards the right by the cyst, it is advisable to empty this organ completely, as a preliminary measure, by abstinence from food and by the use of the siphon irrigator. Except in my case, the incision has always been made in the *linea alba*. It seems to me that the incision should be made over the most prominent part of the tumor, and as nearly as possible over the seat of the obstruction. In following this rule, we select the place where we are most apt to find adhesions, at the same time that we establish the straightest and most direct route to the primary origin of the cyst. An incision

through the linea alba, or parallel with the costal arch, will afford the easiest access, with a minimum risk of injury to important parts. The external incision should be at least four inches in length, while the peritoneum should be opened only to the extent of two inches, for the purpose of making an exploratory examination, the opening to be enlarged as occasion may require. If adhesions are found between the cyst and the omentum and the parietal peritoneum, the cyst is punctured with an exploring needle, and, if the diagnosis is corroborated, the operation is finished by incising and draining the cyst. If no adhesions are found between the omentum and the peritoneum, the former is incised so as to expose the cyst-wall, when either of the following plans may be pursued. The parietal peritoneum is stitched to the skin with catgut. The margins of the omental wound having been pushed back under the abdominal walls so as to expose the cyst freely, the wound is packed from the bottom with iodoform gauze, and an antiseptic dressing is applied and retained for six or eight days, or until adhesions have formed between the cyst and the margins of the wound which effectually shut off the peritoneal cavity, when the cyst is incised and drained.

Suturing of the cyst-wall to the margins of the wound as a preliminary operation should never be resorted to, as on account of the thinness of the cyst-walls there is danger of escape of fluid into the peritoneal cavity from the punctures made by the needle, an occurrence which the procedure was intended to obviate. With proper care, however, the operation can be completed at once. The cyst-wall is grasped with two many-toothed forceps, and drawn forward so as to bring it in accurate and close contact with the margins of the wound, when the fluid is removed with an aspirator or a trocar with the same care as would be employed in emptying an ovarian cyst. As the cyst becomes empty it is pulled through the wound, which obviates any further danger of escape of fluid into the peritoneal cavity. When the cyst is nearly empty it is freely incised and sutured to the peritoneal lining of the abdominal wound. The drainage-tube should be fully three-quarters of an inch in diameter, and must reach from the bottom of the cyst to the surface of the wound. After emptying the cyst completely by compression, and placing the patient on his side, a large Lister dressing is applied, for the purpose of guarding against infection and to absorb the secretions. Frequent change of dressing may be required on account of copious escape of pancreatic secretion. Past experience would dictate the advisability of protecting the skin against the digestive action of the pancreatic juice by applying freely carbolated oil. The antiseptic dressings should not be abandoned until the peritoneal cavity has become completely closed by firm adhesions and the size of the cyst has been reduced to a fistulous tract. The drainage-tube is shortened from time to time, as the depth of the fistulous opening is diminished by obliteration of the cyst from the bottom of the tract. The speedy obliteration of the cyst will depend on the continuance, abatement, or removal of the obstructing cause, or the condition

of the gland-tissue distal to the seat of obstruction. If the stricture in the common duct of the pancreas is complete and of a permanent character, the obstruction will continue, and, if healthy gland-tissue remains on the distal side, the fistula will continue to discharge pancreatic juice. If the inflammation which caused the obliteration of the duct subsides and the passage again becomes permeable, the natural outlet will be again established and the artificial duct will become obliterated. If an impacted calculus has caused the retention and the fistula continues to discharge, a careful examination should be made to detect the calculus, and, if found, an effort should be made to remove it through the fistulous opening. If the obstruction has become permanent and the gland-tissue on the distal side has become destroyed either by the cause or causes which produced the obstruction or by the intra-cystic pressure, that portion of the organ has been deprived of its functional capacity, and, as no pancreatic juice is secreted, definitive obliteration of the cyst and permanent closure of the fistulous tract will take place in a comparatively short time.

#### CARCINOMA.

It is asserted by some pathologists that primary cancer of the pancreas does not occur, and that in cases where this organ is the seat of the lesion it occurs as a secondary affection, having reached it by extension from an adjacent organ, especially from the pyloric extremity of the stomach. While this may be true in many cases, a considerable number of specimens have been examined where the disease occurred here as a primary affection. Suche appears to have examined a specimen which affords a good illustration of primary cancer of the body of the pancreas. The middle of the gland was converted into a hard, irregular, nodulated mass, the size of a fist, resting directly upon the aorta, which imparted to it pulsation during life. When cut into, the tumor grated under the knife, and the cut surfaces presented a laminated appearance. The substance of the tumor was traversed by numerous large veins; both extremities of the pancreas were healthy, and no secondary nodules could be found in any portion of the body. A primary cancer of the pancreas is also described by Schupmann, where the tumor had formed adhesions with the spleen, while the liver contained a number of metastatic deposits. The terminal extremity of the pancreatic duct contained a cylindrical calculus with a number of arborescent projections, which corresponded to the contributory ducts. In another case, reported by Récamier, the cancerous tumor, which involved the tail of the pancreas, was connected with the left kidney and compressed the ureter. The right half of the pancreas was healthy, the diseased portion gray, hard, and lardaceous. The pelvis of the left kidney, in consequence of the compression of the ureter, was hydronephrotic. The remaining organs were healthy.

Bright, in 1832, reported a number of cases of primary carcinoma of the pancreas, with a special view of illustrating the effect which disease

of this organ has upon the digestion of fat. In three out of eight cases he noticed fatty diarrhoea, and he was inclined to the belief that this symptom, when present, is almost pathognomonic of the existence of disease of the pancreas. In all cases the fatty diarrhoea was associated with jaundice. According to Da Costa, cancer of the pancreas is more frequent in the male than in the female, and preferably attacks people over forty years of age. That even young children are not exempt from cancer of this organ is well shown by a case recently reported by Kühn.

The patient was a child only two years of age. The most prominent symptoms were progressive anemia and obstinate diarrhoea. Syphilis could be excluded. Towards the last there was general anasarca and the liver was enlarged, but the spleen and the lymphatic glands appeared normal. Careful auscultation and percussion revealed nothing abnormal in the organs of the chest; the urine was normal, except that it contained a trace of albumen. At the post-mortem a slight serous effusion was found in the left pleural cavity. The lower lobe of the left lung was consolidated and brownish red in color. In the solid portion of the lung a white, firm nodule about the size of a hazel-nut was found. The upper lobe of the right lung contained an infarct nearly the size of the nodule in the left. The abdominal cavity contained some serum. Kidneys normal in size, capsule non-adherent, parenchyma granular, light-red color, pyramids more dark. Pancreas hardly of normal size, contained a firm tumor, the surfaces of a cross-section presenting a grayish-white appearance. Under the microscope this tumor showed the characteristic structure of a cylindrical-celled carcinoma. The tumor had evidently started from an embryonal matrix of epithelial cells in some portion of the pancreatic duct and had given rise to embolic dissemination in the terminal branches of the pulmonary artery.

Another case of rapidly-growing primary carcinoma of the pancreas in a child only six months old has been reported by Bohn.

Carcinoma of the pancreas usually appears as a firm tumor or scirrhus, with a well-developed connective-tissue reticulum. Other varieties of carcinoma have been described. Thus, Wagner observed a cylindroma, and Lücke and Klebs have each met with the colloid variety. The primary starting-point is usually in the head of the organ, whence it extends in all directions. By extension within, it successively invades the body and tail of the organ, until the whole gland is involved, when it forms a nodulated spherical tumor. The extension of the growth in an opposite direction soon reaches the duodenum, where it produces a narrowing or complete stenosis of that portion of the intestinal canal. A case of this kind is related by Hoelscher, where the duodenum was constricted to such an extent that it was entirely impermeable, and the patient suffered for several days from symptoms of intestinal obstruction. While cancer of the stomach is liable to extend to the pancreas, the converse is not frequently observed. When the carcinoma develops primarily in the pancreatic ducts, it belongs to the variety called cylindroma. The lymphatic glands in the vicinity of the pancreas are invariably affected during the later stages of the disease.

**Symptoms and Diagnosis.**—Stearrhoea is an important but not an infallible symptom of cancer of the pancreas. It is attributed to an absence of the pancreatic juice in the intestinal canal, caused either by obstruction

in the duct or by suspension of the physiological function of the organ by the neoplastic infiltration. Epigastric pain is an early and important symptom, and is the result of compression of the celiac plexus by the tumor. The pain often assumes a neuralgic character, and is usually not aggravated after taking food. Vomiting is a frequent symptom, and the matter ejected is generally a watery fluid, sometimes stained with bile. Constipation is an almost constant symptom. Progressive emaciation and anemia attend malignant disease in any locality, but are unusually well marked in cancer of the pancreas. When the disease extends towards the duodenum, jaundice occurs from stenosis of the bile-ducts by compression or direct invasion by the neoplasm. Bruen has called attention to some forty cases of jaundice due to primary carcinoma of the head of the pancreas, lately reported by another observer, from which it is demonstrated that jaundice is an invariable symptom of primary scirrhus of the head of the pancreas, while it is uncommon when the disease is secondary or affects the body or the tail of the organ.

The most reliable evidence is the appearance of a tumor in the epigastrium behind the stomach. The difficulty of examining the pancreas during health by palpation is appreciated when a physical examination is to be relied upon in locating tumors in this locality. The normal pancreas can be felt only under the most favorable conditions through a thin and relaxed abdominal wall, but in determining its relative size this method of examination affords little reliable information. A cancer of the pancreas, where it can be felt by palpation, appears in the epigastrium as a hard, immovable or only slightly movable tumor, which is evidently deeply seated in the abdominal cavity. Under favorable conditions the connections of such a tumor with the pancreas can sometimes be demonstrated during life, but a positive diagnosis becomes impossible when, as in most of the cases hitherto recorded, it constitutes merely a part of a general tumefaction of the abdomen. As the tumor is in such close proximity to the abdominal aorta, the pulsations of this vessel are imparted to the tumor, and a bruit may even be heard over the compressed vessel; but, in contradistinction to aneurism, the pulsation is felt in only one direction, and the bruit disappears when the patient is placed in the knee-elbow position, as the tumor is lifted from the vessel by the force of gravitation.

That the tumor cannot always be felt is evident from the statement made by Da Costa that he recognized it in only thirteen out of the one hundred and thirty-seven cases he reported; and Bigsby, in an analysis of fifteen cases, alludes to its being recognized in only four.

From what has been said, it will be seen how uncertain the symptoms are in the diagnosis of cancer of the pancreas. A satisfactory conclusion can be reached only after a careful consideration of the history of the case combined with a systematic elucidation of all the symptoms presented, and more particularly by resorting to the advantages to be derived from a systematic and careful study by exclusion.

**Treatment.**—A positive diagnosis of malignant disease of the pancreas is possible only after the tumor has attained sufficient size to be recognizable by palpation, consequently too late for a radical extirpation. When the disease has advanced to this stage it has already involved the greater portion of the gland, and, as a rule, has invaded important adjacent organs. Another important element in the surgical treatment of cancer of the pancreas consists in the fact that the disease, as a rule, develops primarily in the head of the organ, a location which in itself precludes the propriety of an operation. The most favorable conditions for extirpation are presented if the disease is primarily located in the tail of the pancreas and has not passed beyond the limits of the capsule of the gland. In such a case excision of the splenic extremity of the pancreas would offer a fair prospect for a permanent result without endangering, as a remote consequence, the process of digestion, as a sufficient amount of secreting structure would remain in connection with the intestine to maintain pancreatic digestion.

Billroth in two instances made a partial resection of the pancreas in removing carcinomatous tumors of adjacent organs. In one case he removed a portion of the head of the pancreas with a cancer of the pylorus, and in another case he removed the tail of the pancreas with a sarcomatous spleen. Both patients recovered from the immediate effects of the operation. In the case of partial excision of the head of the pancreas it is to be assumed that the duct was not injured, that the organ continued to secrete, and that the pancreatic juice was discharged into the duodenum through the uninjured duct. In operating upon the head of the pancreas for malignant disease which has extended to it from an adjacent organ, it is essential to preserve the continuity of the duct, so as to prevent physiological detachment of the remaining portion of the gland, an accident which would be followed by degeneration and complete atrophy, and consequently by suspension of pancreatic digestion. If an operation is performed for cancer of an adjacent organ, and the disease has extended to the splenic extremity of the gland, the operation should not be completed without removing a sufficient portion of the pancreas to guard against a local recurrence of the disease in this organ. As in cases of partial excision of the pancreas for other lesions, the pancreas should be ligated before it is divided, so as to prevent troublesome hemorrhage and at the same time guard against extravasation of pancreatic juice into the peritoneal cavity.

#### TUBERCULOSIS OF THE PANCREAS.

Primary tuberculosis of the pancreas is an exceedingly rare affection; indeed, some pathologists, among them Louis and Lebert, doubt its primary origin in this organ. Cruveilhier only mentions tubercular degeneration of the lymphatic glands upon the surface of the pancreas. In diffuse miliary tuberculosis of the abdominal organs Klebs could find no nodules in the substance of the pancreas on microscopical examination. But in such a condition the gland is often found in a state of parenchymatous degenera-

tion, which has been incorrectly interpreted as the first stage of tuberculosis by Ancelet.

When the lymphatic glands around the pancreas have undergone cheesy degeneration, we sometimes find similar deposits in the pancreas, which, however, may be cheesy lymphatic glands in the substance of the pancreas itself. Hartmann mentions a case where the pancreas had disappeared completely and its place was occupied by a cheesy mass.

Bamberger found a large abscess of the pancreas in a tubercular patient in whom during life no symptoms, either objective or subjective, pointed to the pancreas as the seat of suppuration. Although the pancreas is not disposed to tuberculosis, we have reliable information that in a number of cases this gland was the primary seat of the process.

While in most of the reported cases of primary tuberculosis of the pancreas the symptoms during life pointed to disease of this organ, a sufficiently positive diagnosis to warrant a laparotomy could have been made only after a palpable tumor appeared, and by that time the disease would have passed beyond the reach of successful surgical treatment through the appearance of the miliary deposits in other organs, an occurrence which would render any operative interference unjustifiable. Should abdominal section be performed in a case of tubercular peritonitis, and should such a condition in the pancreas be found as in a case described by Aran, it would be proper to extirpate the terminal end of the pancreas exclusive of the tubercular abscess.

In a case reported by Wilson, the tubercular deposit in the pancreas gave rise to a large abdominal tumor due partly to the distended gall-bladder; and, as such a condition might present itself to the surgeon in these days of diagnostic laparotomy, it might be advisable, and to the advantage of the patient, to establish an external pancreatic fistula instead of closing the wound. Such a course would enable the surgeon to remove the cheesy material, and to disinfect the abscess-cavity and to treat its interior with iodoform, all of which, done under antiseptic precautions, would tend to modify favorably the local process.

The removal of compression of the bile-duct by the same procedure would also tend to re-establish the interrupted communication between the bile-duets and the duodenum by removing the cause of the stenosis.

#### SYPHILIS.

Syphilitic lesions of the pancreas have been found, both as a tertiary manifestation of syphilis and as a congenital affection. Sometimes the entire gland, sometimes only portions of it, may be the seat of the disease: in these latter cases a circumscribed sclerosis, either with or without gummata, may be found. Lancereaux believes that many cases of sclerosis of this organ result from syphilis. In newly-born children and in the fetus unmistakable evidence of degeneration of the pancreas in connection with hereditary syphilis has been frequently demonstrated. In such a case



Cruveilhier found the pancreas transformed into an amyloid swelling. Oedmannsson found alterations in the pancreas in children suffering from congenital syphilis, consisting of extensive fatty degeneration of the parenchyma-cells and advanced interstitial sclerosis. Klebs described several gummata in the pancreas along with syphilitic changes in other internal organs of a six months' fœtus.

Birch-Hirschfeld found thirteen times in twenty-five cases interstitial connective-tissue hyperplasia in the pancreas in the hereditary syphilis of newly-born children.

Demme reports the following interesting case. At the time of birth the child weighed two thousand eight hundred and forty grammes, and exhibited a well-marked papular syphilitic eruption over the lower extremities. For ten days the child was immersed daily for a short time in warm water in which one and a half grammes of corrosive sublimate had been dissolved, with the result of improving the skin-affection. The child suffered constantly from diarrhœa, and the stools contained undigested fat. The urine contained a trace of albumen; otherwise it was normal. After the suspension of the baths inunctions of mercurial ointment in daily doses of a quarter of a gramme were used for ten days, and were followed by marked improvement. Abdominal distention and tenderness as well as the icterus which had existed were greatly diminished, and the weight of the child increased considerably. Diarrhœa less, but character of stools unchanged. After this apparent improvement the symptoms again became more aggravated, and, from the effects of an exhaustive diarrhœa and progressive marasmus, the child died thirty days after its birth. On post-mortem the lungs presented a collapsed appearance and the heart-muscle was of a grayish-brown color. In the walls of the left ventricle near the apex several gummata were found. Slight ascites; liver normal in size and structure, with the exception of a few gummata in the lobus Spigelii. Pancreas firm, small, and grating under the knife. Serous coat of duodenum hyperemic, with isolated spots of ecchymosis; spleen and kidneys normal. In this case the syphilitic lesion in the pancreas had advanced to the stage of sclerosis.

Demme's treatment, as described above, should be imitated in all cases of congenital syphilis of the pancreas.

---

#### BIBLIOGRAPHY.

- Rokitansky, Nebenpancreas in der Darmwand, Virchow's Archiv, Bd. xxi. S. 369;  
 Lehrbuch der pathologische Anatomie, Wien, Bd. iii. S. 168.  
 Remak, Entwicklung der Wirbelthiere, Berlin, 1855, Ss. 54, 115, 164.  
 Schiff, Canstatt's Jahresbericht, 1861, 1-3, S. 119.  
 Hermann, Lehrbuch der Physiologie, Berlin, 1882, S. 107.  
 Laborderie, Gazette des Hôpitaux, 1856, No. 2.  
 Nussbaum, Die Verletzungen des Unterleibes, 1880.  
 Gross, Elements of Pathological Anatomy, Philadelphia, 1857.  
 Haller and Klob, Schmidt's Jahrbücher, 1860, Bd. i. S. 306.  
 Delafield and Prudden, Pathological Anatomy and Histology, New York, 1885, p. 369.  
 Todd, Dublin Hospital Reports, vol. i.  
 Moore, Pathological Observations on the Pancreas, St. Bartholomew's Hospital Reports, vol. xviii. p. 207.  
 Perle, De Pancreas ejusque Morbis, Dissert., Berol., 1837.  
 Haggarth, Transactions of the College of Physicians in Ireland, vol. ii.

- Senn, *The Surgery of the Pancreas as based upon Experiments and Clinical Researches*, Philadelphia, 1885; *The Surgical Treatment of Cysts of the Pancreas*, Chicago, 1885.
- Kramer, *Centralblatt für Chirurgie*, No. 2, 1885.
- Engel, *Oesterreich. Med. Jahrb.*, Bde. xxiii. u. xxiv., 1841.
- Johnston, *Calculus and other Affections of the Pancreatic Ducts*, *American Journal of the Medical Sciences*, October, 1883.
- Koreff, *Diss. sistens theoreticam Considerationem Icteri novis quibusdam Causis simul superstructam*, Halle, 1763.
- Gould, *Anatomical Museum of the Boston Society*, Boston, 1847, p. 174.
- Pepper and Hjett, *Transactions of the Pathological Society of London*, vol. xxiv.
- Dobrzycki, *Fall von beweglicher Bauchspeicheldrüse*, *Virehow u. Hirsch's Jahresbericht*, 1878, Bd. ii. S. 215.
- Ancelet, *Études sur les Maladies du Pancréas*, Paris, 1867.
- Pepper, *American Journal of the Medical Sciences*, 1871, p. 159.
- Heidenhain, *Archiv für die gesammte Physiologie*, Bd. xiv. S. 466.
- Suche, *De Scirrho Pancreat. nonnulla*, *Dissert.*, Berol., 1834.
- Schupmann, *Hufeland's Journal*, 1841.
- Récamier, *Revue Médicale*, 1830.
- Bright, *Cases and Observations connected with Disease of the Pancreas*, *Medico-Chirurgical Transactions*, vol. xviii. p. 1.
- Da Costa, *North American Medico-Chirurgical Review*, September, 1858.
- Kühn, *Jahresbericht der gesammten Medicin*, 1887.
- Bohn, *Centralblatt für die gesammte Medicin*, 1885, No. 41.
- Wilson, Mayo, *Outlines of Human Pathology*.
- Demme, *Ueber die Affectionen des Pancreas im Kindesalter*, *Wiener Med. Blätter*, 1884, No. 51.

# FUNCTIONAL DISORDERS OF THE LIVER, JAUNDICE, AND DISEASES OF THE DUCTS AND OF THE PORTAL VEIN.

BY HENRY DWIGHT CHAPIN, M.D.

---

IN considering the subject of affections of the liver, the first things to attract attention are the relatively large size and the apparent functional importance of this organ in early life. For a correct understanding of these facts we must go back and consider some of the phenomena of fetal life. The liver is then a very important factor in the circulatory system, while the lungs are largely inactive. It is somewhat surprising to learn that in the mature fetus the liver holds a quarter or more of the entire volume of blood, and that it is greater in size than both lungs. A brief review of some peculiarities of the foetal circulation will help to a further understanding of this subject. (Fig. 1.)

The passage of arterial blood from the placenta to the fetus takes place through the umbilical vein in the umbilical cord. At the umbilicus the umbilical vein enters the abdomen of the fetus and reaches the under surface of the liver after passing along the free margin of the suspensory ligament. Several branches are given to the left lobe as well as to the lobus quadratus and lobulus Spigelii. The umbilical vein divides into two branches at the transverse fissure. The larger branch, after being joined by the portal vein, enters the right lobe. The smaller branch forms the ductus venosus, which joins the left hepatic vein as it enters the inferior vena cava. The blood which leaves the placenta for the nutrition of the fetus through the medium of the umbilical vein reaches the inferior vena cava in three different ways. The great bulk of it circulates through the liver with the portal venous blood and passes into the vena cava through the hepatic veins. A part enters the liver directly by branches of the umbilical vein, and, after circulating through this organ, reaches the vena cava also by means of the hepatic veins. Finally, a small quantity passes directly through the ductus venosus and by its junction with the left hepatic vein enters the vena cava.

As the lungs of the fetus are solid and almost impervious, the placenta of the mother performs the double function of a respiratory and of a

nutritive organ. After the venous blood is received from the foetus it must be returned reoxygenated, and nearly the whole of this purified stream is

FIG. 1.

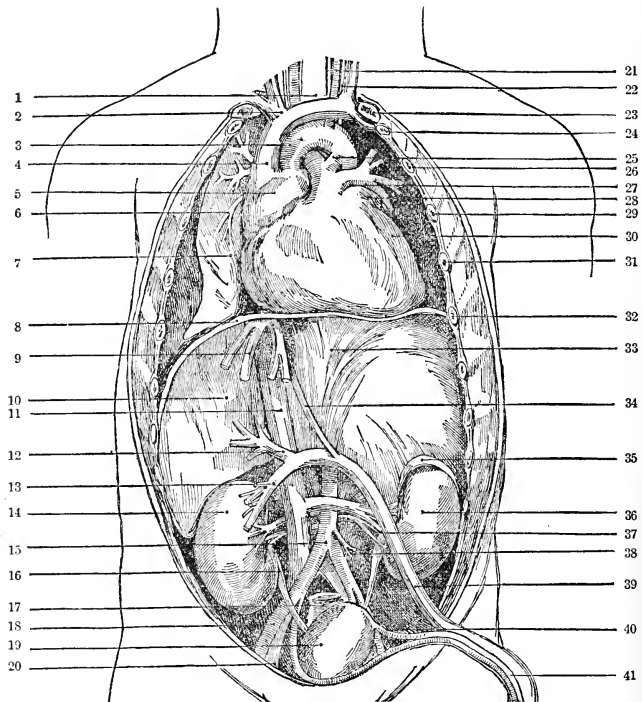

THE FETAL CIRCULATION, SHOWING THE RELATIVE POSITION OF THE ORGANS, drawn by Dr. McClellan from dissections and preparations in his cabinet.—1, the trachea, with the carotid arteries on either side; 2, the right innominate vein, overlying the innominate artery; 3, the arch of the aorta; 4, the superior vena cava; 5, the right auricle; 6, the right pulmonary vessels passing into the unexpanded lung; 7, the right lung packed in the back of the thorax; 8, the diaphragm; 9, hepatic veins; 10, the right lobe of the liver, dissected to show branches of portal and hepatic veins; 11, inferior vena cava; 12, right branch of portal vein; 13, portal vein coming from the intestines, which are removed; 14, right kidney; 15, bifurcation of aorta into the two common iliac arteries; 16, right ureter; 17, rectum tied; 18, right external iliac artery and vein; 19, bladder; 20, right hypogastric artery; 21, left recurrent laryngeal nerve; 22, left pneumogastric nerve; 23, left clavicle; 24, first rib; 25, ductus arteriosus; 26, second rib; 27, left pulmonary vessels; 28, left auricle; 29, third rib; 30, left ventricle; 31, fourth rib; 32, fifth rib; 33, crura of diaphragm; 34, ductus venosus (the left lobe of the liver, stomach, pancreas, and spleen are removed); 35, left supra-renal capsule; 36, left kidney; 37, left renal vessels; 38, inferior mesenteric artery; 39, umbilical vein; 40, left hypogastric artery; 41, umbilical cord.

carried to the liver by the umbilical vein and circulates through this organ before reaching the vena cava and the general circulation.

The large size and the importance of the liver in foetal life are thus understood by considering it a sort of intermediary organ between the placenta and the general circulation, as far as the reoxygenated blood is concerned.

At birth the communication between the placenta and the liver and portal vein, by means of the umbilical vein, is severed by cutting the cord. The lungs at once inflate and assume the respiratory function. The umbilical vein begins to shrink, and becomes completely obliterated between the second and fifth days after birth. It finally becomes the fibrous cord known as the round ligament of the liver. The ductus venosus also usually becomes completely obliterated a few days after birth.

Although the liver has now lost its preponderating importance in the economy, it still remains relatively larger and heavier than in later life. The diminution of the organ is due to its altered blood-supply, and is especially marked in the left lobe. The loss of weight that begins at birth continues, so that there is a direct ratio from infancy to old age in this relative diminution. At birth the liver-weight is in proportion to the whole body as 1 to 28; in infancy, 1 to 20; at puberty, 1 to 30; in adult life, 1 to 35; in middle life, 1 to 40; in old age, 1 to 45. The following is taken from a table of Frerichs in reference to the relative and absolute weight and size of the liver under normal conditions at different ages.<sup>1</sup>

AGE.	WEIGHT		RELATIVE WEIGHT OF LIVER TO THAT OF BODY.	DIMENSIONS OF LIVER.				
	OF BODY.	OF LIVER.		Length.		Breadth.		Thickness (greatest).
				Right Lobe.	Left Lobe.	Right Lobe.	Left Lobe.	
	Kilogr.	Kilogr.		Par. in.	Par. in.	Par. in.	Par. in.	Par. in.*
Six months' foetus	1.3	0.060	1 : 21.6	2 $\frac{3}{4}$	2	2	1 $\frac{3}{4}$	2 $\frac{2}{3}$
New-born child.	1.6	0.056	1 : 28.57	2 $\frac{1}{2}$	2	2	1 $\frac{1}{4}$	1
Five weeks . . .	1.95	0.090	1 : 21.66	2 $\frac{1}{2}$	2	1	1 $\frac{1}{2}$	1
Five years . . .	8.8	0.48	1 : 18.3	3 $\frac{1}{4}$	4 $\frac{3}{4}$	4 $\frac{3}{4}$	2 $\frac{1}{2}$	1 $\frac{1}{2}$
Eleven years . .	24.8	0.97	1 : 25.56	6 $\frac{1}{4}$	3	6 $\frac{1}{4}$	3 $\frac{1}{2}$	3 $\frac{1}{2}$
Thirty-five years	32.0	0.82	1 : 39.0	6	4 $\frac{1}{4}$	5 $\frac{1}{4}$	2 $\frac{1}{2}$	2

\* One Paris inch contains 12 Paris lines, but an English inch only 11.25 Paris lines.

Upon ligation of the umbilical cord and ending of the placental circulation there follow great changes not only in the infant's circulation but also in the blood itself. These changes appear to be at first of a degenerative nature, and follow a more perfect oxygenation of the blood. Immediately after birth the red corpuscles number six or seven millions per cubic centimetre, while by the fourth or fifth day the number has dropped to four or five millions. According to the observations of Hofmeier,<sup>2</sup> the size of the red corpuscles at birth is very variable, and the white corpuscles are often in greater proportion than in adults' blood. Various ring-like forms have been seen in the blood of new-born infants, which are supposed to be the skeletons of red corpuscles after the coloring-matter has disappeared.

<sup>1</sup> A Clinical Treatise on Diseases of the Liver, 1879.

<sup>2</sup> Zeitschr. f. Gynaek. u. Geburtshelk., xiii. 12.

Hæmoglobin is thus transferred from the stroma of the corpuscle to the plasma. As a result of the destruction of red and white corpuscles, there will be a relatively large quantity of fibrin-ferment in the blood in conjunction with the hæmoglobinæmia. In healthy infants the liver will convert the liberated hæmoglobin into biliary coloring-matter in a few days, which will be partially liberated by the fæcal discharges and urine. Silbermann<sup>1</sup> sums up the condition of the blood as follows:

1. The blood of the newly-born contains corpuscles which vary greatly in size, and also the so-called "shadows."

2. It is richer in fibrin-ferment than is the blood of adults.

3. These peculiarities are due to the liberation of hæmoglobin and its transfer to the plasma.

4. The richness in fibrin-ferment of the blood of the newly-born predisposes them to disease.

5. All disease-processes in the newly-born which involve great destruction of the albumen of the circulation are especially dangerous to life.

It is strange that morbid conditions referable to the liver should not be more frequent in early life, and particularly during the first few days of life, when we consider the profound changes in its circulation following the obliteration of the umbilical vein and ductus venosus, together with the degenerative changes in the blood going on at the same time.

---

## ICTERUS.

**Synonymes.**—Jaundice; French, Ictère; German, Gelbsucht.

The word icterus seems to have been derived from two sources. Some refer its original derivation to an animal, the weasel, having yellow eyes. Others consider the term to be derived from the bird called icterus that was supposed to die upon being viewed by a jaundiced patient, the latter immediately recovering. Jaundice comes from the French word "jaune," meaning yellow, and signifies a yellowish coloring of the skin. The German term "gelbsucht" is not now much used, being superseded by icterus.

There are many grades of icterus, due to several causes and appearing at different periods of life.

### ICTERUS EMBRYONUM.

The earliest occurrence of icterus is where the fœtus of a jaundiced woman is found to have this affection. Frerichs considers that the woman must be jaundiced for several weeks before the fœtus can be likewise affected, since in cases where the mother was jaundiced from five to fourteen days before delivery the fœtus was free from the disease. Icterus embryonum is an exceedingly rare affection, very few cases being reported in the

---

<sup>1</sup> Jahrb. für Kinderheilkunde, xxvi. 2.

literature of the subject. In some instances the jaundiced infants have been born before term, and in others born dead at full term. Legg<sup>1</sup> quotes two cases from Wrisberg in which autopsies had been made and a dissection showed the gall-ducts to be plugged with mucus. The prognosis is not always fatal, as occasionally recovery has taken place.

#### ICTERUS NEONATORUM.

New-born babies so frequently become jaundiced that this especial liability deserves a separate name and different consideration from the same affection occurring in older children. Many different theories have been advanced to explain the etiology and frequency of icterus at this period of life. All the cases may be divided into two general classes,—the mild and the grave or malignant. The former class will be first considered.

MILD ICTERUS NEONATORUM.—Two divergent theories have been advanced to account for the milder grade of icterus neonatorum. The first considers the jaundice to be purely of hæmatic origin. The excessive amount of hæmoglobin which is present in the blood at this early period is decomposed under the influence of some fermentative agent, and an elimination of this coloring-matter produces the jaundice. The second theory regards the jaundice as hepatic. Bile is first formed in the liver and then carried into the circulation, the reabsorption being due either to congestion of the blood-vessels or to œdema of the hepatic tissue. It seems highly probable that both these theories may be true in different instances, and doubtless many cases of icterus neonatorum are to be satisfactorily explained only by taking into consideration a morbid condition of both the blood and the liver, thus combining the hæmatic and hepatic theories.

The experiments of Stern are interesting in this connection. He succeeded in removing the liver from pigeons and producing hæmoglobinæmia, but failed in inducing icterus. From these experiments the presence of the liver would seem to be necessary to produce the jaundice, in addition to a large amount of coloring-matter circulating in the blood. It is generally considered that the coloring-matter of the bile is a derivative from the coloring-matter of the blood, but the transformation takes place by means of the liver. In vigorous, healthy infants the liver will change the liberated hæmoglobin into biliary coloring-matter in a few days, and this will be eliminated by the excreta. If the infant is feeble or diseased this transformation and elimination will not so readily take place, and jaundice will be one of the results. The transference of bile into the blood may be favored by an anatomical peculiarity at birth. Thus, the theory of Quinke explains certain cases of icterus on the ground that the ductus venosus may remain open for some time after birth, thereby allowing a part of the portal blood containing bile to pass directly into the general circulation. Ashby reports a case in which an autopsy showed the ductus venosus to be widely open in

---

<sup>1</sup> Bile, Jaundice, and Bilious Diseases, 1880.

a jaundiced infant who died on the eleventh day. He believes that this duct is liable to remain open longer in feeble and immature infants than in more vigorous ones. Jaundice is certainly much more likely to develop in the former than in the latter class of infants. The resorption theory of Frerichs considers that the pressure in the portal capillaries is greatly lessened upon the cutting off of the placental circulation. Following this decreased tension, the bile-capillaries will be subjected to an increased tension, which will be aggravated by the secretion of bile taking place at birth. An effusion of bile will then ensue, with absorption into the lymphatics or veins of the liver, and the bile will thus reach the blood in large quantities. Silbermann,<sup>1</sup> who has given this subject a good deal of thought and investigation, reaches the following conclusions:

1. Icterus neonatorum is icterus of resorption, and, therefore, hæmatogenous in character.

2. The biliary engorgement is seated in the biliary capillaries and interlobular bile-duets, which are compressed by the dilated branches of the portal vein and the capillary blood-vessels of the liver.

3. This engorgement of the vessels is effected by a change in the circulation of the liver, occurring soon after birth, which is one of the indications of a change in the blood-plasma.

4. This change, which is induced by the destruction of many blood-corpuscles soon after birth, consists in a kind of blood-fermentation.

5. The more feeble the infant the more intense will be the icterus, for in such a child the destruction of corpuscles and the consequent blood-changes will be much more decided than in a vigorous child.

6. As a consequence of the destruction of so many red corpuscles, there is abundant material for the formation of biliary coloring-matter, and, under the influence of the fermentation-process alluded to, this coloring-matter accumulates for a long time and in considerable quantity in the hepatic vessels.

D'Espine and Picot<sup>2</sup> sum up their consideration of the pathology of benign icterus by stating that in all cases the ordinary icterus of the newly-born, without our being able to affirm that it may be always due to the same cause, presents clinically the same characteristics as the icterus due to an active or passive hepatic congestion.

**Symptoms.**—The intense congestion of the skin observed during the first few hours or days of life often produces a yellowish coloration that cannot be considered a jaundice, since it is not dependent upon the secretion of bile. It is of the same nature as the discoloration of the skin following an ordinary cutaneous bruise. The yellow tint is at first seen only on deep pressure, but as the erythema fades the yellowness increases. The conjunctivæ are not colored, and the urine appears normal. This yellowness is

<sup>1</sup> Arch. f. Kinderheilk., Bd. viii. II. 6.

<sup>2</sup> Maladies de l'Enfance, 1884.



usually first noticed on the second day, and may continue a few days or a week.

The term "true icterus" can be applied only to those cases in which the yellow discoloration of the skin is caused by a staining by the bile-pigments. This more often occurs in cases of prolonged or difficult labor, in infants born asphyxiated or before term, and in generally feeble infants. It is very frequently seen in foundling asylums. Kehrer observed jaundice in four hundred and seventy-four out of six hundred and ninety newly-born infants at Vienna. Not infrequently, however, icterus neonatorum will occur under the best hygienic conditions. It may appear as early as a few hours after birth, but usually is not well marked until the second or third day. The early invasion of this trouble is shown by the statistics of Kehrer, who found that out of four hundred and seventy-four jaundiced infants five and three-tenths per cent. were affected on the first day, sixty-two and nine-tenths per cent. on the second, and twenty-four and one-tenth per cent. on the third, while a few began from the fourth to the seventh day. In very mild cases the yellowness may appear only on the face, chest, and back, the conjunctivæ being only faintly tinted and the urine and fæces normal in appearance. If the case be more marked, the urine may be high-colored enough to stain the linen, and the yellowness may extend to the arms and abdomen. Some infants present a yellowish discoloration of the whole body, with typical clay-colored stools. In most cases the jaundice has disappeared by the eighth or tenth day. It may, however, persist for several weeks. In rare cases, after having much diminished, it reappears with renewed intensity. No matter how well marked or extensive this form of jaundice may be, it appears to cause very little constitutional inconvenience. The liver may be slightly enlarged, and occasionally there are symptoms of intestinal catarrh.

Hoffmeier has shown that the loss of weight during the first few days is much more considerable in icteric than in non-icteric infants, and that the increase in weight is slower. The general health is unaffected after the disappearance of the benign form of icterus neonatorum. In the rare cases in which death has occurred during the existence of the icterus, it has been from some other cause.

GRAVE ICTERUS NEONATORUM.—The grave form of icterus neonatorum is, fortunately, very rare, and may be produced by several different conditions. Defects in the bile-ducts will first be considered, as among the commonest causes. In some cases all the large bile-ducts have been absent; in others the ductus communis choledochus has been narrowed, obliterated, or entirely absent. Sometimes a fibrous cord has been found in place of the gall-duct. The cystic duct has been absent and the gall-bladder in a rudimentary condition. Accompanying an obliteration of the gall-ducts, a condition of cirrhosis is usually found in the liver, which will be more or less marked according to the length of time that the infant survives. The liver is generally found enlarged.

As an example of defective duct, Dr. Oxley<sup>1</sup> reports a case of congenital atresia of the duodenal opening of the common bile-duct, producing a large abdominal tumor. A female infant five weeks old was brought to the Infirmary in a jaundiced and emaciated condition. There was a round, globular, tense swelling of the abdomen, dull on percussion over the right side and part of the left, except the left lumbar region, where it was resonant. A canula was inserted into the upper line of the right lumbar region, and thirty-six ounces of bile flowed away in about twenty minutes. In three days the swelling had reappeared, although not so large, and sixteen ounces of bile were withdrawn. The urine was bile-stained, and the motions were like white curds. The infant died in a few days, and an autopsy showed a globular tumor, about the size of a cocoa-nut, below the free margin of the liver. The duodenum coursed over its surface and was closely adherent to it. Both the cystic and the hepatic duct were patent and opened into the tumor. The gall-bladder was of normal size, but contained no bile, and no opening into the intestine could be found. On examining the duodenum, the papilla indicating the usual orifice of the common bile-duct was seen, but it was quite impervious.

Dr. Danforth has reported a case in which the ductus communis choledochus was entirely absent, although the cystic and hepatic ducts presented a normal appearance. The child died in profound coma seventy-two hours after birth. The discoloration of the skin was of a bronzed character. Two cases are reported by Dr. A. D. Campbell in which there was deficiency of the cystic and hepatic ducts. Dr. John B. White gives the history of a jaundiced infant dying on the twelfth day. The autopsy showed an enlarged liver, with hepatic ducts presenting no abnormal appearance, but an evident constriction of the cystic duct, while the common duct was impervious throughout its length. In place of this duct there existed a fibrous cord-like band extending to the duodenum.

Dr. White<sup>2</sup> has collected reports of eighteen cases in which fatal jaundice was produced by some malformation or deficiency of the bile-ducts. Dr. Henry Ashby<sup>3</sup> reports a case of fatal jaundice in an infant of six weeks. On dissecting out the vessels in the transverse fissure, the gall-bladder was found to be undersized, with a small cystic duct which entered the common duct and passed on, being of very diminutive size, but pervious, to the duodenum. No hepatic duct could be found, the biliary duct apparently ending in the fibrous tissue present in the fissure.

An arrest or failure of proper development of the gall-ducts may occur several times in the same family. The common duct is originally a solid structure, being formed from a protrusion of the intestinal mucous membrane growing into the blastemic mass of the liver.<sup>4</sup> Any factor that may interfere with the normal and complete evolution of this structure will cause fatal infantile icterus. It has been suggested that maternal impressions may at times have an influence in producing such a condition. In these cases of atresia of the bile-ducts the liver is usually in a state of incipient cirrhosis. Dr. Legg has called attention to the fact that cirrhosis of the liver will follow a ligature of the ducts in animals. Jaundice that is due to obstruction or obliteration of the biliary passages may appear a few hours after birth and soon acquire a marked intensity. It often, however, does not appear for one or two weeks after birth, and at its inception presents a light yellow tint that soon becomes darker. In cases of obliteration of the cystic duct alone the jaundice may not appear until much later,

<sup>1</sup> London Lancet, vol. ii., 1883.

<sup>2</sup> American Journal of Obstetrics, January, 1888.

<sup>3</sup> Archives of Pediatrics, September, 1884.

<sup>4</sup> Glaister, London Lancet, vol. i., 1879.

possibly not until several months after birth. The yellowish discoloration of the skin may vary from day to day, at times being much more intense than at others. The conjunctivæ are yellow. The faecal discharges lose color and have an offensive odor, while the urine stains the diaper a yellow or greenish brown. Both the liver and the spleen are usually enlarged, which partially accounts for the increase in size of the abdomen. Such enlargement is increased by the flatulent distention of the bowel produced by decomposition of food. There is marked wasting of the infant, although nourishment may be taken in large quantities. Umbilical hemorrhage is a grave and not infrequent symptom in this form of jaundice. The bleeding is not sudden and profuse, but begins as an oozing shortly after the sloughing of the navel-string. It is apt to commence at night. Death is always hastened by this accident, as exhaustion from loss of blood is added to that induced by indigestion and malassimilation. There may also be a sort of general purpura, bleeding taking place from the nose, mouth, or stomach. It has been suggested that the umbilical hemorrhage is due to the portal congestion that is secondary to cirrhosis. Since the circulation of the liver is much obstructed, the blood passes to the ductus venosus from the left portal vein and thus reaches the umbilicus. The vessels are here not strongly enough closed to resist this pressure, and hence bleeding results. Children may live for several months with impervious or defective bile-ducts, although death usually takes place earlier, from lack of nutrition. Where umbilical hemorrhage supervenes, however, a fatal ending is not long to be averted. Death may take place in a few hours, or, at most, in a few days.

Another grave form of icterus in the newly-born is seen in connection with septic poisoning that is generally accompanied by umbilical phlebitis. The umbilicus is a very vulnerable spot for the entrance of septic poisons shortly after birth. Upon ligation of the cord, the blood that remains in the umbilical veins forms small thrombi, that should gradually harden and in time become calcified, forming a fibrous cord in the same manner as in the ductus arteriosus and ductus venosus. In these latter structures the formation of thrombi is never accompanied by grave consequences, since their internal situation prevents the access of irritating agents. Infected air or pus, however, can readily enter the umbilical vein from the umbilicus, and thus start up umbilical phlebitis and general septicæmia. There is a constant alteration after birth in the blood-pressure in the umbilical vein, due to the action of the heart and lungs, by which a sort of flux and reflux is produced. This suction-action favors an infection of the system when the contents of this vein become septic. This grave accident is liable to occur when the mother is in a septic condition. The poison may be introduced by bacteria, which are probably the same agents that produce puerperal fever. In these cases of sepsis there is a puriform or yellow softening of the thrombi that fill up the umbilical vein. This softened matter consists of pus-corpuseles and finely granular matter containing

micrococci. This sets up an inflammation not only in the vessel itself, but also in the surrounding tissues. Infective emboli may be carried to various parts of the body. As the micrococci enter the umbilical vein from the umbilical fossa, owing to the perviousness of this vessel, the structures near at hand, especially the liver, bear the first brunt of the septic inflammation. The latter organ is usually found much diseased or degenerated.

Dr. J. L. Smith<sup>1</sup> reports a case in which an infant who was born healthy began to be feverish on the fifth day, which was followed by a series of abscesses indicating septic infection. The cord separated at the usual time, and the umbilicus appeared healthy. When the child was two months old, a prominence appeared half an inch above the umbilicus, which was punctured in a week, when bile instead of pus escaped. The opening closed soon afterwards, and subsequently a discharge of bile occurred from the umbilicus, which continued until death, at the age of eight months. At the autopsy a probe was passed from the umbilicus into and along the umbilical vein. The umbilicus seemed normal, except a small cicatrix at its right. The umbilical vein was dilated to about twice its normal size, its walls were infiltrated and thickened, and it contained yellow, thickened bile. One of the branches of the vein traced into the liver opened into an abscess about the size of a walnut, and contained thick pus, and through this abscess a communication had been established between the umbilical vein and the bile-ducts. The gall-bladder and the hepatic and cystic ducts contained bile and appeared normal; and the liver, except for the abscess, presented a normal appearance. The abscess was in the right lobe, near its posterior border, and extended to the superior surface of the liver. The umbilical vein contained bile, with perhaps some bile-stained pus, but no blood. In these cases there may be inflammation of the umbilical artery as well as of the umbilical vein.

This septic form of jaundice comes on shortly after birth, usually within a few days, and is soon well marked. It is presumably due to pressure on the bile-ducts by swelling of the connective tissue around the branches of the portal vein in the liver. This form of jaundice is clinically distinguished from other varieties by the constant elevation of temperature and by other symptoms of general septic infection. If the infant lives long enough, objective signs of peritonitis will probably develop, and sometimes of empyema or even of meningitis. In all cases evidences of severe illness and prostration are present. Cutaneous, mucous, or visceral hemorrhages may supervene at any time. The abdomen is generally swollen and tender, and dirty-looking pus may be seen oozing from the navel: slight pressure around the umbilicus will often cause the appearance of this pus if it is not otherwise apparent. The faecal discharges may be of a natural appearance, but the urine is usually very highly colored. The infant refuses nourishment, and may be troubled with vomiting of a greenish matter. Severe nervous symptoms, such as convulsions or coma, are apt to supervene before death.

A third cause of grave icterus neonatorum is found in certain inflammatory changes in the liver, usually taking the form of an interstitial hepatitis, with which may be conjoined inflammation of the biliary canals. This lesion in the liver is apt to be one of the results of congenital syphilis,

---

<sup>1</sup> Diseases of Children, 1886.

as is likewise perihepatitis, which may cause a complete obliteration of the biliary passages. The latter form of inflammation is particularly apt to involve the connective tissue surrounding the common duct, the portal vein, and the hepatic artery on the under surface of the liver. These cases, however, may not always be of syphilitic origin.

D'Espine and Picot report a case in which a jaundiced infant was apparently healthy until the ninth day. At that time there appeared hemorrhages under the skin, at the umbilicus, and in the intestine. The infant became gradually very feeble, and succumbed on the twenty-third day in convulsions. The parents presented no trace of syphilis, and the infant never showed upon its body any appearance of a specific eruption. The autopsy showed a profound change in the hepatic tissue, which appeared to have been the point of departure of all the accidents. The liver was increased in size, and the large biliary canals were permeable. The hepatic tissue, of a greenish-olive color, showed under the microscope an abundant proliferation of young cells in the capsule of Glisson and in the interlobular spaces. This neof ormation was continued under the form of elegant garlands around the hepatic cells in the interior of the lobules. The cells were in large part preserved, and contained particles of biliary pigment. The small biliary canals were thickened and filled with epithelial cells: the slight alteration of their lumen permitted the supposition that the lesions they presented were consecutive to the interstitial hepatitis. No gummy points were found. The umbilical vein presented no change. The kidneys were slightly enlarged and very icteric; they presented some disseminated ecchymoses and a cellular proliferation around the arteries which give rise to the vasa recta. The point of departure of all these lesions appears to have been a hypertrophic cirrhosis of the liver with inflammation of the biliary canals.

**Diagnosis.**—The first point to consider is the diagnosis between true benign icterus neonatorum and false jaundice. In the latter case, the discoloration being due to the remains of a severe cutaneous congestion, there is a yellowish-brown tint usually present, while in true jaundice the color of the skin is more markedly yellow. In true jaundice the conjunctivæ and urine usually present an icteric tint, which is absent in false jaundice. Before deciding upon the actual color of the skin, it may be necessary to employ enough pressure to drive out the blood. The grave form of jaundice may be suspected when the discoloration, instead of disappearing gradually, becomes more and more marked. In the case of congenital defects in the biliary ducts, a slow wasting is conjoined to the jaundice, but without a rise in temperature. The liver and spleen are nearly always increased in size, and there may be at any time a supervention of umbilical hemorrhage. If these latter symptoms are present with atrophy, a malformation of the bile-ducts can be diagnosed although the jaundice be slight or variable. Septic jaundice is recognized by the local symptoms of phlebitis, such as the oozing of discolored pus or blood from the umbilicus, and the symptoms of a general septic poisoning, such as elevated temperature, general sickness and prostration, and possibly a swollen abdomen, that may be very painful on pressure. In cases due to interstitial hepatitis or perihepatitis, besides the local signs referable to the liver, there is apt to be present some trace of congenital syphilis. A careful inquiry into the family history of the father and mother will sometimes throw light on an obscure case.

**Prognosis.**—Jaundice often causes great alarm in the minds of the laity, possibly from a knowledge of certain fatal cases. It is only necessary to make the distinction by the symptoms in a given case between benign and grave icterus neonatorum in order to be able to give in one case an absolutely good prognosis and in the other an equally bad one. The mere presence of jaundice without other rational or physical signs in a young infant need excite little alarm. I have recently seen a case in which an infant was born jaundiced and remained so continuously for several months. Although the discoloration was deep and well marked, the baby remained plump and healthy, and suffered no inconvenience whatever from this symptom. In cases, however, in which jaundice persists and there begins to be noted an enlargement of the liver, with some wasting, a serious prognosis had better be given. Life is generally most prolonged in the grave form where there is malformation of the ducts. An infant suffering from this lesion may live several months. If umbilical hemorrhage supervenes, death is not long delayed. In umbilical phlebitis with general septicemia, and in hepatitis, death is usually unavoidable.

**Treatment.**—The mild form of benign jaundice will often get well without any treatment. In some cases a mild laxative seems to hasten the result. A few tablet triturates of calomel, from a twentieth to a quarter of a grain, given every few hours, often do well. Several grains of gray powder, repeated once or twice, may likewise do good service. Sometimes an alkali, such as bicarbonate of sodium, seems to hasten the disappearance of the jaundice. Two or three grains can be given three times a day. Careful attention must be paid to the digestive organs of the infant. Nursing babies are often put to the breast much too frequently for the good of their digestion. If the nursing be restricted, a teaspoonful of water can be allowed in the intervals. In bottle-fed babies great care must be exercised to dilute and prepare the milk properly, and in many such ways to relieve all digestive disturbances. If there be syphilitic hepatitis, constitutional treatment directed to the specific taint will be indicated. Septic jaundice must be treated by free stimulation and all other measures that can be employed in sepsis. In cases of umbilical hemorrhage applications of strong astringents, such as the perchloride or subsulphate of iron, may be made. If this does not avail, it may be necessary to apply a ligature around two hare-lip pins inserted through the skin at the navel.

#### JAUNDICE AFTER EARLY INFANCY.

The jaundice that attacks infants some time after birth is due to causes that are similar to those found in children and adults. The bile passes into the blood, owing to some obstruction to its discharge through the biliary canals into the intestine. A catarrhal inflammation of the duodenum, accompanied by swelling of the mucous membrane at the opening of the ductus communis choledochus, may be responsible for the obstruction. The inflammation may extend by continuity from the duodenum to the ductus

communis and hepatic ducts and thus cause retention of bile in the liver. There may be causes of obstruction within the ducts that are not due to inflammation. Among these may be mentioned a plug of inspissated bile in the common duct, and, more rarely, gall-stones. Cases have been recorded where a round worm has penetrated the common duct from the duodenum, thus producing complete obstruction. Various inflammatory changes in the liver may produce sufficient pressure to cause obstruction in the intra-hepatic ducts. Thus, the atrophic cirrhosis of the liver sometimes seen in early life may be one of the causes of jaundice. Malarial and miasmatic poisons and phosphorus-poisoning may finally be mentioned as causes of jaundice in children.

**Symptoms.**—The yellow discoloration of the conjunctivæ and skin is the same as in *icterus neonatorum*. A symptom often noted is a slow pulse, perhaps forty or fifty beats to the minute, as bile when present in the blood has a sedative effect upon the circulation. The biliary salts are the ingredients of the bile that produce this effect. If there be much slowing of the circulation, the respirations will likewise diminish somewhat in frequency. The most marked symptoms that may be present are those that can be referred to a duodenitis or a gastro-duodenitis. In the latter case there is more or less nausea and vomiting, with pain in the epigastrium, especially upon the ingestion of food, and tenderness upon pressure in this region. There may be a subacute duodenitis without gastritis being present. If so, there is pain and distress when the food passes from the stomach into the duodenum, which usually occurs some hours after the taking of nourishment. Conjoined with this there is tenderness on pressure below the epigastrium at the situation of the duodenum. In these cases a plug of mucus is often found in the common duct where it opens into the duodenum. When jaundice occurs without these inflammatory conditions being present, the nutrition does not for a time appear to suffer, as the appetite may remain good and the digestion of certain articles of food be fairly well accomplished. The fats, however, are digested with difficulty, and the fecal discharges may contain more or less undigested fat. A careful study of the stools may aid in deciding how complete the obstruction to the passage of bile into the intestine may be. The stools are clay-colored, from an excess of undigested fat, when no bile reaches the intestine. On the other hand, they have somewhat the natural brownish-yellow color when the obstruction to the passage of bile is only partial. One of the known physiological properties of the bile is to act as a sort of natural disinfectant and antiseptic to the contents of the intestinal canal. The complete absence of bile will hence be shown by a quick decomposition of the intestinal contents, as exhibited in the free formation of gases and the foul odor of the feces when voided. The bowels are generally, but not always, constipated. Itching of the skin may cause great annoyance, especially at night when the skin is warm. Urticaria, which is an exceedingly common affection in children, may occur as an obstinate complication, when the

papules and wheals will present a deep-yellow tint. Jaundice may persist for a long time without giving rise to much apparent disturbance, as the system assumes a tolerance of an excess of bile as of other abnormal substances. It may act principally upon the mental powers in the way of producing a sort of stupidity that may be closely allied to somnolency.

**Diagnosis.**—The principal point to determine in a given case is the pathological cause that has produced it. Evidence of the existence of gastro-duodenitis or duodenitis must first be sought. When there is nausea or vomiting, with pain about the region of the epigastrium, that has preceded and accompanies the jaundice, these conditions may be recognized as causative. If the ducts are inflamed from other causes than a duodenitis, such as a round worm in the common duct, the diagnosis cannot be made during life. If careful palpation reveals a distended gall-bladder, there is positive evidence of obstruction in the common duct.

In cases in which jaundice is merely a symptom of some structural affection of the liver, not only diagnosis but also treatment must be adjusted with reference to the latter lesion. The jaundice is simply one among other symptoms. In many cases, however, a careful examination of the liver will fail to reveal any anatomical lesion to explain the jaundice. We must then fall back on an empirical diagnosis by the mere discoloration of the skin. It is necessary to bear in mind, however, the fact that jaundice may be distinguished from other abnormal tints of the skin simulating it by the yellowish conjunctivæ and by the presence of biliary pigment in the urine. The latter condition is absent in the yellowish-green tint sometimes seen in chlorotic girls, and in any other abnormal discoloration of the skin.

**Prognosis.**—The prognosis in a given case will, of course, be dependent upon the ascertained cause of the jaundice. Even when the original cause has ceased to operate, some time usually elapses before the discoloration completely disappears. The fluid tissues, such as the blood and urine, are the first to be free of biliary pigment, which remains longer in the solid tissues. As the epidermis is gradually desquamated, the yellow discoloration fades out of the skin. If the jaundice is due to gastro-duodenitis, the prognosis is good, as recovery usually takes place in from two to three weeks. The first indication of removal of the obstruction to the passage of the bile is the appearance of stools that are more normal-looking. If the color becomes darker gradually, it is evidence that the obstruction is disappearing by degrees. If the common duct is occluded by a plug of mucus which is suddenly detached, the feces will at once be surcharged with bile. A jaundice that persists indefinitely, even where no organic disease can be found, must not be regarded without apprehension. If the general health and strength be good, a jaundice may last for several months without occasioning any special alarm; but cases are sometimes seen where the condition persists for one or two years, and then there are apt to be grave changes in the nutrition of the patient. While the mere accumula-



tion of bile in the system does not appear to produce serious symptoms, the retention of bile in the liver for a certain length of time may produce grave changes in this viscus. The smaller and larger biliary ducts become distended by the pent-up bile, which finally may infiltrate the liver-cells, thus interfering with their function. Sometimes the gall-bladder is distended with bile. The liver is at first increased in size, from its being filled with bile, but finally becomes atrophic. If this process continues, death will finally take place with symptoms of exhaustion or blood-poisoning. Such cases are rare at all ages, and are not so common in children as in adults. Sometimes even mild cases of jaundice may suddenly present evidences of blood-poisoning, which may be followed by death. Fortunately, the majority of cases of jaundice seen in young children disappear in a few weeks without leaving any serious consequences.

**Treatment.**—The most rational treatment of jaundice is that which is aimed at its cause. As a matter of fact, however, the treatment is often necessarily empirical. Whatever the cause, certain symptoms are usually present that must be alleviated by treatment. Persistent constipation is one of the commonest of these symptoms. In making a choice of laxatives, those which act upon the lower segment of the bowel often do well. Small doses of aloes, rhubarb, or castor oil will fulfil this indication. Drugs which act by irritating the duodenum or the upper part of the small intestine are apt to aggravate the trouble in the common cases of duodenal catarrh. The treatment of jaundice that is most effectual is employed in those cases depending on a subacute inflammation of the stomach and duodenum, and resolves itself into treating the latter conditions. The saline laxatives or mineral waters are best used to cause a suitable action of the bowels when there is catarrh of the duodenum. Karlsbad, Vichy, Congress, and Kissingen waters usually act well. Great care must be exercised in diet, only bland and easily-digested food being allowed. All fatty articles must be restricted, and the patient kept upon lean meat and plain vegetable food. Sometimes counter-irritation in the shape of a small blister at the epigastrium appears to do good.

If there are no marked evidences of gastro-duodenal inflammation, more vigorous means to excite the secreting functions of the intestine and increase peristalsis may be employed. Active peristaltic action in the duodenum may be transmitted to the bile-ducts, and thus a beginning obstruction be overcome. Calomel, rhubarb, aloes, and colocynth may be mentioned in this connection. The action of an emetic, by forcibly compressing the liver and bile-ducts, may free the passages from obstruction. In vigorous children ipecac or a small dose of tartar emetic at the start may prove beneficial. Alkalies, particularly the bicarbonates of sodium and potassium, are supposed to have a liquefying effect upon the bile and thus to free the ducts when they are occluded by a thickening of this secretion. In some cases they appear to have a good effect, whatever may be their mode of action. Tincture of nux vomica may be combined with advantage when

one of these salts is prescribed. Nitro-hydrochloric acid is highly recommended by some authorities. Henoch claims good results for it in obstinate catarrhal jaundice.

When jaundice persists and resists ordinary treatment, efforts must be directed to eliminating some of the bile from the system by means of the emunctories. This is to be done by the kidneys and cutaneous glands. The mild vegetable diuretics, the acetate of potassium, and various mineral waters, such as seltzer, have been recommended. Frerichs advises that lemon-juice be given, from one to three ounces daily. He finds that it agrees well with the digestive organs and excites an abundant diuresis. The skin may be kept acting freely by warm baths and by having pure flannels worn to guard against changes of temperature. At the same time, in these prolonged cases everything must be done to support and invigorate the system, so as to obviate as much as possible the depressing effects of the cholæmia.

The first sign of improvement, in case of a favorable issue, will be the disappearance of the biliary coloring-matter from the urine. The real affection has then ceased, although the skin may retain its jaundiced hue for some time longer.

---

## DISEASES OF THE BILIARY DUCTS, ETC.

The affections of the biliary ducts in children practically resolve themselves into an inflammation secondary to a like pathological condition of the gastro-intestinal mucous membrane, as the lining membrane of the duodenum is directly continuous with that of the bile-ducts; also to the occasional wandering of entozoa from the intestine into these ducts. Disease of the ducts produces trouble principally by leading to a retention of the bile, but sometimes the liver-tissue itself may be secondarily involved.

### CATARRH OF THE BILIARY DUCTS.

A catarrhal inflammation of the ducts of the liver will present changes similar to those seen in other mucous membranes. One effect often seen as a result of inflammation in this part is a collection of mucus, often taking the form of a firm plug, at the opening of the common duct into the duodenum. This is a frequent cause of the complete obstruction seen in these cases. An ordinary acute catarrh of the biliary ducts usually undergoes complete resolution in a few weeks without any bad results being left behind. If the inflammation becomes chronic, certain secondary lesions may develop. A thickening of the ducts, with dilatation in places, caused by the obstructed secretion, may result. Rarely, ulceration may take place in the walls of the ducts. The mucous membrane of the gall-bladder may be the seat of catarrhal inflammation and the ducts not be involved. This

takes place from thickening and alteration of bile that has remained for a long time stagnant in the gall-bladder.

**Etiology.**—Since in the large majority of cases the inflammation spreads by direct continuity from the duodenum into the common duct, the causes producing irritation of the former structure must be considered in this connection. Acute indigestion produced by overloading the stomach with all kinds of improper food and drink will stand as the commonest cause. Certain infectious diseases, and acute or chronic malarial attacks, may cause enough gastro-duodenal irritation to provoke an actual catarrhal inflammation. These affections may likewise act as causes of catarrh of the biliary passages by inducing a hyperæmic condition of the liver which is shared in by the ducts.

**Symptoms.**—The disease is apt to begin with various digestive disturbances, shown by a coated tongue, nausea or vomiting, and a disinclination to take food. There may be a slight fever and other symptoms pointing to a mild catarrh of the stomach. In a few days the conjunctivæ begin to be tinged with yellow and the urine is colored by biliary pigment. Soon a marked jaundice develops, and the feces lose color, assuming the well-known clay-like appearance. There is often a slight enlargement of the liver, which projects a little below the ribs, and the gall-bladder may likewise be felt projecting below the margin of the liver, assuming a sort of pear-shape. The jaundice accompanying this affection generally lasts two or three weeks, although it may not disappear for two or three months when the inflammation of the duodenum and bile-ducts is severe or chronic. At first there is tenderness on pressure over the epigastrium and the right hypochondrium. When the inflammation of the ducts is secondary to congestive changes in the hepatic tissue, there is less digestive disturbance, and the jaundice is not only fainter in degree, but is also not apt to last so long. Its duration will, of course, depend upon the nature of the original hepatic disturbance. If the gall-bladder alone is the seat of catarrhal inflammation, there will be no jaundice, and the symptoms in general will be very indistinct. The gall-bladder may sometimes be mapped out as a pyriform swelling, which may be the seat of a dull pain.

**Diagnosis.**—The diagnosis consists in recognizing the existence of a gastro-duodenal catarrh, or, after eliminating this, in carefully seeking for some affection of the parenchyma of the liver that may induce a catarrhal inflammation of the biliary ducts.

**Treatment.**—The treatment is essentially the same as that recommended for ordinary jaundice in children.

#### ROUND WORMS IN THE BILE-DUCTS.

It happens very rarely that round worms find their way into the biliary ducts and produce grave or fatal symptoms. When we consider the active movements of this worm and its tendency to invade different cavities, the wonder is that the biliary passages are not oftener invaded. Although the

worm enters by the common duct, it is usually found in the gall-bladder or one of the branches of the hepatic duct. Cases have been recorded where a worm has been found partly within the common duct and partly in the duodenum. Several worms may be present in the ducts, and they may cause inflammation, with obstruction or dilatation of the passages. Occasionally ulceration may result. Frerichs mentions a case reported by Lieutaud where a boy of fourteen years was attacked with fever and painful distention of the epigastrium and of the region of the liver, with salivation and jaundice; the stools lost their color, the pulse became intermittent, and death took place in convulsions. At the autopsy the liver was found to be yellow and enlarged; the gall-bladder was distended with bile, and the common duct was blocked up by a good-sized round worm, while large numbers of similar worms were found in the stomach and intestinal canal. The symptoms in these cases are too obscure to warrant a diagnosis. There may be acute pain in the epigastrium, with vomiting, and finally convulsions, from reflex irritation of the filaments of the hepatic plexus. As the diagnosis is uncertain, the treatment must be directed to symptoms.

#### INFLAMMATION OF THE PORTAL VEIN.

Suppurative pyelephlebitis only will be considered, as the adhesive variety occurs very rarely, if ever, in early life. The former variety occurs as a secondary lesion, resulting from suppuration in some of the organs drained by the portal vein or its radicles. Ulcerations of the gastro-intestinal mucous membrane, resulting from inflammation induced by various foreign bodies or by hard masses of impacted faecal matter, may be recognized as a not unusual cause. Pylephlebitis may be secondary to inflammation or ulceration of the biliary ducts. Typhlitis or perityphlitis or chronic peritonitis may likewise give rise to suppuration within the portal vein. Umbilical phlebitis in new-born infants whose mothers are septic may spread to the portal system and set up inflammation there.

**Symptoms.**—The symptoms of the primary morbid condition are usually to be noted before the signs of inflammation in the vein itself.

Pain in that part of the portal vein or its branches which is involved in the inflammation is the first local sign of disturbance. This is followed by enlargement of the liver and spleen, which become tender on pressure. The pain in the liver may be due to a general hepatitis or to the formation of abscesses in this organ. A complete occlusion of the splenic vein leads to considerable swelling of the spleen and to pain in the left side. As pus forms in the portal vein, there will be chills, fever, sweating, and other hectic symptoms. The patient rapidly emaciates, and exhibits such typhoid symptoms as low delirium and somnolence. Sometimes before there are such evidences of blood-poisoning there may be vomiting, swelling of the abdomen, which becomes extremely painful, and other signs of a general peritonitis. In many cases there is diarrhoea, with bilious stools that may contain a little blood. Jaundice develops during some part of the progress

of the disease in a majority of the cases. The skin and urine may be only slightly colored, however. There may be some remission in the severity of the symptoms, but the disease generally reaches a fatal termination in a few weeks.

**Diagnosis.**—It is difficult, if not impossible, to make an early diagnosis, from the obscurity of the symptoms. Attention may first be directed to some local inflammation and suppuration in the course of the portal vein. If, following this, there is severe pain somewhere in the course of the vein, with rigors and sweating, more or less marked jaundice, enlargement of the liver and spleen, bilious stools, and rapid failure of the vital powers, the diagnosis of portal pylephlebitis can pretty certainly be made. It must be remembered that the symptoms may finally resolve themselves into blood-poisoning and general peritonitis.

**Prognosis.**—The prognosis is always fatal, unless only a small radicle of the portal vein is involved in the inflammation.

**Treatment.**—All that can be done in the way of treatment is to make the patient as comfortable as possible and to treat symptoms as they arise. The pain and diarrhoea may be relieved by opiates, and the general strength sustained as long as possible by the use of a nutritious diet and stimulants.

#### LITHÆMIA.

Children frequently suffer from a functional disturbance of the liver that gives rise to various digestive and nervous symptoms. These are similar to those seen in adults affected with lithæmia, and the principal objective evidence of faulty nutrition will be found in the urine. The tongue is coated and the breath offensive. Constipation is usually present, and the stools are pasty and lacking in bile. There is an unhealthy appetite, sometimes abnormally large, and the children have a pale, sallow appearance. Complaint is commonly made of headache. Young children become extremely fretful when suffering from this affection. They wish to urinate frequently, and a reddish-pink sediment of urates is deposited in the chamber. Anæmic girls are very apt to become lithæmic before or at the time that they begin to menstruate.

**Treatment.**—The first object of treatment is to get the bowels acting regularly. A few small doses of calomel may be first given, followed by fluid extract of cascara sagrada or aloes. Nux vomica combined with an alkali, such as bicarbonate of potassium, or an acid, such as dilute hydrochloric acid, may then be administered. Good effects will often be had by changing from an acid to an alkali, or *vice versa*. The child's diet should be carefully regulated. Too much meat, as well as an excess of starchy food, must be avoided. Pastry and sweets must all be cut off. Plenty of out-door exercise, well-ventilated rooms, salt baths with friction of the skin, and all kinds of beneficial hygienic measures to improve the general health, may be employed with advantage.

# ENLARGEMENTS OF THE LIVER:

THE LIVER OF CHILDREN; AFFECTIONS WHICH SIMULATE ENLARGEMENT OF THE LIVER; CONGESTION OF THE LIVER; FATTY INFILTRATION; AMYLOID DISEASE; HYDATID DISEASE; ABSCESS; TUMORS OF THE LIVER.

By J. H. MUSSER, M.D.

---

AFFECTIONS of the liver occurring in childhood have received but little notice from systematic writers on the diseases of this period of life. The literature of the various diseases, therefore, is quite scanty.

The reason for this is obvious. The liver plays an important physiological part in the growth and development of childhood, but, fortunately, is not often the seat of pathological changes during that period. When one recalls the etiology of liver-diseases, this is readily understood. Practically, all affections of the liver occurring in adult life are due to habits (sedentary, gall-stones), and to errors in diet (fatty liver, congestions, cirrhosis, singly or combined), or occur secondarily to some grave cachexia or some form of disease in distant organs. These causal processes operate over long periods of time, and therefore either they are rarely operative in childhood, or sufficient time does not elapse for the pathological changes to take place. Hydatid disease, in countries where it prevails, occurs more frequently than any of the other grave affections, and is the only exception to the statement just made.

As the various affections of the liver are rare, it does not fall to the lot of one man to see many of them, and hence the writers on diseases of children were loath in the past to discuss the subject. A similar hesitancy has existed until within a short time. The growth of population and the increase of special hospitals for children have, however, made it more practicable for single observations to be made. The accumulated results of the more careful observations scattered through the literature of medicine form sufficient data for intelligent writing on any diseases of the liver incident to—or, rather, occurring in—childhood. This literature is rendered acces-

sible by the growth of libraries and the perfect system of cataloguing of the Library of the Surgeon-General's Office at Washington. Without the advantages one derives from this institution it would be an herculean task to perform thorough literary work. To the marvellous growth of literature and the readiness of access to it, the writer is indebted for any degree of completeness that this essay may possess. The works on diseases of children which have been consulted are given in the foot-note on this page.<sup>1</sup> In addition, special articles were consulted, reference to which will be found after each individual section.

The lack of an exact pathology, and a want of harmony in the nomenclature of hepatic diseases, have also been great obstacles to the growth of any accurate knowledge of hepatic diseases. Hence much confusion has existed in the past on this account.

The most frequent diseases of the liver that occur in childhood cause enlargement of that organ. The importance relatively of this portion of the subject, therefore, calls for a rather extended notice of the various diseases of this character, as well as for preliminary remarks on the size of the liver and its anatomical relations in childhood, especially as there are some differences in this period of life from the liver of adult life. After the introductory remarks, the various affections which may simulate an enlargement of the liver—or, as Murchison states it, may cause spurious enlargement of the organ—will be treated of. Finally, the affections of the liver causing enlargement will be detailed in systematic order.

#### THE LIVER OF CHILDREN. .

In another portion of this work the relative proportion of the weight of the liver to the weight of the entire body during the various periods of life, as well as a statement regarding its size, is given. This is constantly referred to by writers, and it shows that the liver of a child is much larger relatively than the liver of an adult. The increased size is particularly seen in the left lobe, although there is uniform enlargement of the right lobe. The functions of the liver in fetal life call for this

<sup>1</sup> *Bibliography.*—Armstrong, George; Astruc, John; Baginsky, D. A.; Barrier, F.; Baudin, J.; Becquerel, Alfred; Bedford, Gunning S.; Bird, Golding; Boerhave, H.; Burns, John; Cadet de Gassicourt; Campbell, William; Capuran, J.; Chambon de Montaux; Cheyne, John; Churchill, Fleetwood; Clarke, John; Coley, J. M.; Condie, D. Francis; Davis, D. D.; Day, W. H.; Dewees, W. P.; Dillnberger, E.; Eberle, John; Eberle and Mitchell; Elliott, George T.; Ellis, Edward; Engel, S. T.; Evanson, R. T.; Finlayson; Gardner; Goodhart, J. F.; Guérignon, J. J.; Guesnard, William; Haden, C. F.; Hamilton, James; Heberden, William; Henke, A.; Hennig, C.; Hillier, Thomas; Hood, P.; James, R.; Laifore, J.; Lee, Robert J.; Le Ferrier, L.; Legendre, F. L.; Leth, J. B.; Löschner and Lambl; Magruder, George L.; Matthews, J. P.; Meigs, C. D.; Meigs, J. F.; Meigs and Pepper; Moss, William; Murdoch, William; Noeggerath and Jacobi; Parrot, J.; Richard de Nancy; Rilliet and Barthez; Roger, Henri; Rosen von Rosenstein; Saunier, J. B.; Schnitzer and Wolff; Schulzius, J. H.; Smith, Eustace; Smith, J. Lewis; Steiner, J.; Stewart, James; Underwood, M.; Ungar, E.; Vidalain, F. A.; West, Charles.

enlargement, its meaning is well understood, and it is explained in another portion of this section. The following table, taken from Birch-Hirschfeld, gives the percentage of weight of the liver in infants and children relative to the whole body-weight. It indicates in another form the statement made above.

In fetus of from seven to eight months . . . . .	5.0 per cent.
“ “ “ eight to nine “ . . . . .	5.0 “
“ child from one day to fourteen days old . . . . .	4.2 “
“ “ six months old . . . . .	6.1 “
“ “ one year “ . . . . .	5.8 “
“ “ two years “ . . . . .	4.3 “
“ “ three “ “ . . . . .	4.7 “
“ “ four “ “ . . . . .	4.8 “
“ “ five “ “ . . . . .	4.0 “
“ “ seven “ “ . . . . .	3.5 “
“ “ nine “ “ . . . . .	4.4 “
“ “ ten “ “ . . . . .	3.2 “
“ “ eleven years old . . . . .	3.8 “
“ “ twelve “ “ . . . . .	3.8 “
“ “ thirteen “ “ . . . . .	4.4 “
“ “ fourteen “ “ . . . . .	3.1 “
“ “ fifteen “ “ . . . . .	4.0 “
“ adults from nineteen to sixty years old . . . . .	2.7 “

Vogel says that the liver of a new-born child weighs, on an average, one hundred grammes, but that of a child sixteen months old two hundred and fifty grammes, so that there is no actual diminution in weight of this organ after birth.

The size and shape of the liver are ascertained during life by palpation, inspection, and percussion. In health on inspection the right side does not materially differ from the left, and in childhood only do we learn of the normal liver and its position by an unwonted fulness in the epigastrium. This is most marked when the child is the subject of a wasting disease which does not cause any change in the size of the liver. Such fulness, with increased dulness on percussio, as will be indicated, has been taken, as the writer has seen, for an abnormal swelling or tumor. In children sometimes on palpation the border of the liver, which in health is an inch below the margin of the ribs, can be detected. The difficulty in feeling the edge is due to the usually tense and fully-distended abdomen of childhood. By inspection aided by palpation, movement of the liver can often be discerned. It is to be remembered, as an important diagnostic point, that the liver descends on normal or full inspiration and ascends in expiration, on account of the action of the diaphragm.

It is by percussion, however, that we most accurately define the borders of the liver, and hence its size and shape. By this means in the right mammary line the upper border of the liver-dulness is found to begin in the fifth interspace; at the right sternal border, in the same interspace; in the axillary line, at the seventh rib; and in the mid-scapular line, at the



ninth rib. This represents the uppermost limit of the liver-dulness on strong percussion, while the superficial line of dulness on light percussion would begin half an inch to an inch below the position indicated. In the median line of the sternum the upper border of the left lobe begins at the articulation of the xiphoid cartilage and extends to within an inch of the umbilicus. The upper border of the left lobe cannot well be distinguished, because of the continuance of cardiac and hepatic dulness in this region. As indicated when speaking of palpation, the lower border of dulness of the right lobe extends below the margin of the ribs. Very frequently this is difficult to determine in children, on account of the flatulent abdomen. It can be determined accurately only by light percussion, while the opposite degree of force is necessary to develop the upper line of hepatic dulness. It is to be remembered that the line of dulness of the upper border is arched, the highest point being in the middle of the axilla.

An enlargement of the liver is ascertained by the above-noted methods, and the nature of the enlargement is inferred by their means, as well as by the use of the aspirating-needle, by which enlargements due to solid growths are distinguished from enlargements caused by fluids.

When the right lobe is enlarged, on inspection the lower portion of the thorax on that side is seen to be much more distended than the corresponding portion of the left side, while if the left lobe is involved the epigastrium is full and swollen. The lower border of the liver can often be seen, but its limits may be accurately defined only by palpation.

By percussion enlargement of the liver is detected, and by the same means it is determined whether the enlargement is uniform or is more marked in one particular direction. Thus, the enlargement may be chiefly upward, extending as high as the third or even the second rib. A cyst on the convex surface, or an abscess in this position in the right lobe, or a new formation, may cause an increase upward. Under such circumstances the respiration, of course, is much interfered with, and hence there is more movement of the unaffected side. Increase of dulness downward is found when there is a uniform enlargement of the organ, as in the fatty or amyloid liver, when neoplasms are situated along or near the lower border of the liver, and when a hydatid cyst develops within the body of the liver. In these affections the upper border is not usually changed, except in amyloid disease.

Irregular enlargement is generally due to a hydatid cyst, and under such circumstances the dulness is either directly upward or directly downward. As pointed out by Ward,<sup>1</sup> it is important to remember that enlargements of the liver, however much they may extend beyond, chiefly occupy the normal site of the organ, and that the usual outline of the liver may be traced. Moreover, such enlargements follow the movements of the diaphragm in full respiration chiefly.

---

<sup>1</sup> Quain's Dictionary of Medicine.

## AFFECTIONS WHICH SIMULATE ENLARGEMENT OF THE LIVER.

Congenital malformation of the liver, and disease of the structures or organs within the thorax or abdomen adjacent to the liver, frequently simulate enlargement of that organ. Murchison and Frerichs particularly call attention to a large number of such conditions, and other systematic writers dwell upon the subject as seen in adult life. Many similar conditions obtain in childhood, some of which will be referred to.

1. **Congenital Malformations.**—Unusual changes in form of the liver, sometimes found at birth, are such as to simulate enlargement of the whole organ. This is seen particularly when the liver has assumed a quadrangular or rounded shape, the area of dulness being increased very much in a vertical direction. Birch-Hirschfeld refers to a case observed by him of enormous enlargement of the liver, symmetrical in form, so that the left lobe corresponded to the right in form and size, on account of congenital absence of the spleen. Such abnormal development must be remembered, and is spoken of here for convenience, as it simulates an enlargement. In cases of congenital diaphragmatic hernia the liver may be found in the right pleural sac, and hence simulate an enlargement upward. Congenital malformations which simulate enlargement may be suspected in the absence of any symptoms of hepatic disease, in the absence of any conditions which may cause other forms of spurious enlargement, and where the increased dulness has existed from early life.

2. **Rickets.**—In rickets the shape of the chest may cause the liver to assume such a position that its area of dulness may be increased and its edges be felt far below the margin of the ribs. Moreover, transverse compression of the liver by the ribs is likely to cause a depression of its surface and elongation of the viscus in the vertical direction.

Disease of the vertebræ often leads to such transposition of the thoracic and abdominal organs as to make it almost impossible to locate them exactly. The normal seat of the liver is often changed, and enlargement may be simulated.

Pseudo-enlargement of the liver must not be confounded with the enlargement which some writers hold to be actually present in cases of rachitis. Jenner, Dickinson, Parry, and others, in their masterly articles, lay great stress upon enlargement of the liver in rickets. Cheadle<sup>1</sup> does not believe that enlargement is caused by this affection; while Fagge, Goodhart, and Gee regard any enlargement which may be present as a result of previous cachexia, apart from rickets. The first writer thinks the enlargements that occur are found only in those forms which are modified by syphilis. He does not consider the matter settled by any means.

3. **Chest-Diseases.**—In children enlargement of the liver may be simu-

---

<sup>1</sup> British Medical Journal, November 24, 1888.

lated by pleural effusions or pneumothorax of the right side, and by pericardial effusions which push the liver downward.

Pleural effusions are more likely to be taken for enlargement of the liver because they often develop latently and without symptoms referable to the lungs. The difficulty in distinguishing a pleural effusion from an enlargement of the liver is great, because the dulness of each is continuous. To guide us in the detection of a pleural effusion the following physical signs may be of service. In a pleural effusion there is uniform bulging of the side. The upper border of dulness of an effusion, if not too large, may be movable. The line of dulness is S-shaped (Garland) if the effusion is small, and horizontal if it reaches two inches above the nipple (Gee). The liver does not ascend and descend synchronously with the respiratory movements, in cases of pleural effusion. Finally, the upper line of dulness of a pleural effusion changes with the position of the patient.

Hepatic enlargement causes eversion of the lower costal cartilages, which is not seen in pleural effusions. A depression may be seen between the lower margin of the ribs and the upper surface of the liver when that organ is pushed down by a large pleural effusion. The use of the aspirator is often necessary to distinguish between the two conditions.

The well-known physical signs of pneumothorax serve to distinguish that affection. In emphysema of the lungs the liver may be displaced downward. In childhood the rickety chest, and the transverse groove which frequently accompanies emphysema, give physical signs which appear to indicate an enlarged liver.

The rational symptoms of dyspnoea, of cough, and of chest-pain are distinguishing features of the thoracic diseases just indicated.

The physical signs of pericardial effusion and of dilated heart are sufficiently well known to require reference only. Of course, to distinguish true enlargement of the liver from the affections just indicated one must weigh the history of the case and the origin and mode of development of the disease, as well as consider the rational symptoms and physical signs.

Hydatid disease and abscess of the liver are frequently complicated by the presence of an effusion in the pleura, either serous in character or containing pus. Frequently the liver-affection had not been thought of, and hence when an empyema or a pleural effusion is detected the condition of the liver must be inquired into. The mode of onset of the disease, and the presence or absence of disease of other organs, as heart-disease or renal disease, which might cause an effusion, must be considered. The tendency of an empyema to become localized and cause a swelling which may appear to be connected with the liver must be remembered.

4. **A collection of fluid** between the upper surface of the liver and the diaphragm may simulate enlargement of the liver. The liver is pushed downward, and hence the area of dulness is increased in that direction. Abscesses and encysted collections of serous fluid between the liver and the diaphragm have been described by many authorities. Murchison details

an interesting example of this condition in a boy aged ten years, in whom, after an attack of scarlet fever, a tumor was found below the right ribs, which increased in size without causing any pain. The globular tumor in the right hypochondrium extended three inches below the level of the umbilicus. It measured six inches over its convexity vertically, and six and one-half inches transversely, and the circumference at its base was fourteen inches. The cartilages of the lower right ribs were slightly everted, and the girth here was one-fourth inch more than on the left side. The tumor was painless, and distinctly fluctuating throughout, and there was no induration at its base. The light of the sun or of a candle was distinctly transmitted through it. When the patient coughed, an impulse was conveyed to the tumor, and when he lay on his back a portion of the tumor seemed to disappear beneath the ribs. The tumor was also largest when he sat up. There was clear vesicular breathing at the base of the lungs, which descended to the normal level both anteriorly and posteriorly. The lower edge of the liver could not be felt through the tumor, which descended slightly on the patient's taking a deep inspiration. There was tympanitic percussion noted between the tumor and the right kidney. The boy's general health was good.

The tumor was aspirated four times, and sero-pus withdrawn. After the fourth puncture the tumor opened spontaneously, and from it a clear viscid fluid continued to discharge for one month. A probe could be passed through the opening inward and downward and outward beneath the abdominal wall to the extent of an inch and a half, but upward beneath the ribs and above the liver to fully three inches.

Bright records a case of large abscess between the diaphragm and the liver, which produced apparent enlargement of the liver. To determine the actual presence of serum or pus in this region, aspiration, of course, is necessary, and, indeed, unless it is performed a diagnosis cannot well be made.

5. **Affections of the abdominal viscera** may cause spurious enlargement of the liver. Under these circumstances the liver is pushed upward and the enlargement is noted in that direction. In cases of ascites, either general or localized in the right hypochondriac region, an apparent enlargement is often seen. When the abdominal cavity is filled with fluid, so that the dulness is continuous with liver dulness, the exact position of the liver can often be determined by having the patient lie on the left side. The general increase of dulness over the abdomen would put one on his guard; but a collection of fluid is often confined by adhesions to one portion of the abdomen, as the right side, and, its dulness being continuous with the hepatic dulness, to distinguish it is very difficult. The occurrence of fluctuation may aid, while the change of the normal outline of the liver and the absence of movement on inspiration, with a history of peritonitis, especially the tubercular form, would indicate an encysted collection of fluid.

Tumors of the ovary, the uterus, or the omentum in children rarely, if

ever, cause an apparent enlargement of the liver by growing upward in apposition to it. Tumors of the right kidney—sarcoma, encephaloid cancer, and cystic disease of that organ—may grow upward in contact with the surface of the liver and cause an increased area of dulness continuous with that of the liver. Moreover, by palpation the edge of the liver cannot well be distinguished. Murchison thinks the fingers can usually be inserted between the ribs and the upper part of the renal tumor. Others affirm that a clear space on percussion over a renal tumor, indicating the presence of the large intestine, can be found. The renal tumor, moreover, does not ascend and descend with the respiratory movements; it partakes somewhat of the shape of the kidney, and is rounded on every side (Jenner).

Accumulation of feces in the transverse colon in adults is a condition difficult to distinguish from enlargement of the liver. In children such accumulation occurs very rarely, and can possibly be detected—or, rather, suspected—by its association with constipation and with spasmodic colicky pains, if the bowels are obstructed. Of course the well-known rule, that the nature or character of a tumor within the abdomen should not be pronounced upon until a purgative has been administered, holds good with tumors in childhood.

6. Some inflammations of the abdominal walls may cause a tumor which can be told with difficulty from one due to an inflammatory enlargement of the liver. Frequently in childhood an abscess in the walls of the abdomen, in the epigastric or the right hypochondriac region, develops slowly and exhibits signs not unlike those of an abscess of the liver. Percussion cannot well define the area, on account of the tenderness and pain; the inflamed area is more tense and fixed than a similar area connected with the liver. In these latent abscesses the constitutional symptoms are less marked than in abscess of the liver.

The writer saw a case of a child two years old with an acute cellulitis, with suppuration, in the hepatic region, which prevented the usual examination of the liver from being made, and hence permitted of the surmise that the abscess originated in the liver. The immediate superficial inflammation, without antecedent local or general symptoms of hepatic origin, characterized the abscess in the abdominal walls.

Murchison calls attention to the rare occurrence of phantom tumors of the abdomen in childhood which may simulate an enlarged liver and most frequently a hydatid of the liver. A girl eleven years of age, of healthy appearance, presented, two years prior to consulting him, a tumor in the epigastrium, which increased for a year and since then had been stationary. She had some dyspepsia, but no pain. A prominent rounded swelling extending from the lower end of the sternum to below the umbilicus was found, and appeared to be due to contraction of the recti muscles. It was for the most part dull on percussion. Its surface was smooth and elastic, but not fluctuating. Over the ensiform cartilage the slightest pressure caused pain. The size of the bulging varied slightly according as the

patient's attention was or was not directed to it. Under anæsthesia the tumor disappeared entirely, but it returned when the effects of the chloroform passed off. Under constitutional treatment for a long time, it gradually diminished, and years afterwards the patient was in excellent health.

#### CONGESTION OF THE LIVER.

Congestion of the liver may be active or passive. Active congestion, or hyperæmia, is seen physiologically after eating. It may become pathological through irritation of the mucous membrane of the stomach by stimulating articles of food. It occurs in the first stage of an abscess of the liver, and in the course of many infectious diseases. Under the influence of high temperature and of malaria, enlargement from congestion is said to take place. Of the infectious diseases, scarlet fever, typhus, and cholera are the most frequent causes.

Passive hyperæmia is a secondary affection, and is caused by anything which hinders the outflow of blood into the ascending vena cava. Heart-disease and diseases which interfere with the pulmonary circulation are the most frequent causes, a stasis of blood in the liver being produced.

Billard says he has seen in the asphyxia of the new-born a congestion so great as to cause a bloody exudation on the surface of the liver, and even an effusion of blood therefrom.

**Morbid Anatomy.**—In active congestion the liver is enlarged, the capsule tense, and its surface red. On section, bright red blood oozes abundantly from the cut surface, and the vessels are distended. The central veins of the acini are not distinct,—indeed, may be seen with difficulty,—on account of the fulness of the other vessels and the pressure upon the central vein by the crowded cells. The structure of the liver is firmer than in health, until a considerable oozing of blood takes place. The hyperæmia is uniform throughout the liver, except when it precedes the formation of an abscess, in which case it is localized, and in some cases of abscess of the liver one sees different areas of hyperæmia which are doubtless the first stages of a commencing abscess.

The liver of passive hyperæmia is much enlarged,—more so than in the enlargement of active congestion; its surface is often irregular; the capsule is dull, and often inflamed in defined areas. The liver is firm on pressure and grits on section. Its color is dark red, and dark blood oozes from the cut surface. The central veins are enlarged and dark, and are surrounded by a zone of gray or yellowish color. The well-known nutmeg-appearance is thus produced. There is frequently an overgrowth of connective tissue which causes the firm structure of the liver. Often the organ is twice or three times its normal size. Generally there is some obstruction of the outflow of bile, and the mucous membrane of the ducts is swollen and congested.

**Symptoms.**—Active congestion of the liver is said to be accompanied with sthenic constitutional, and pronounced local, symptoms. A chill, fol-

lowed by fever which rises to 104° F., with gastric disturbance, headache, mild delirium, and occasionally convulsions, may occur, apart from hepatic symptoms. Locally, in addition to increase in the size of the liver, the hepatic region is the seat of pain, and of tenderness on pressure. The child lies on the affected side, with the limbs drawn up. Vomiting is a quite common symptom, and is often most obstinate. It is not necessarily bilious. The fever abates at the end of forty-eight hours, but the pain and tenderness continue. The general symptoms are relieved and the local ones ameliorated by free action of the bowels and by free perspiration. We are not familiar with the state of the urine during an attack of active congestion of the liver.

The symptoms just indicated are so marked and are so indicative of local inflammation that I fear most cases of active congestion of the liver are really cases of perihepatitis. This is all the more likely if the attacks occur in a syphilitic or in a tubercular subject.

The symptoms of passive hyperæmia of the liver are twofold, and are due, first, to the cause of the passive hyperæmia (affections of the heart or lungs), and, second, to the enlarged liver and the mechanical effects of such enlargement. The first class of symptoms need not be described.

Of the second class, uniform increase in the area of dulness of the liver is found. On palpation, the edges of the liver can be felt, smooth and rounded, as far down as the umbilicus in the median line, and almost to the ilium in the nipple-line. The enlarged liver may cause marked enlargement of the lower part of the thorax and the upper half of the abdomen. With the enlargement of the liver, the spleen is likewise increased in size; the upper half of the abdomen is distended and its surface regular. Abdominal distention becomes very great when ascites takes place. It is impossible to tell whether the ascites is due to the primary lesion or to the secondary change in the liver. After the development of ascites, and possibly from the same cause,—that is, contraction of the liver,—the external abdominal veins may become much enlarged.

In the course of pulmonary disease, and in cardiac disease when failure of compensation occurs, the liver becomes the seat of passive congestion. In addition to the indications shown by the heart and lungs and the physical signs of enlargement of the liver, gastro-intestinal symptoms arise. These symptoms are due to secondary congestion of the mucous membrane of the alimentary tract. The tongue becomes furred, the appetite is lost, vomiting may or may not occur, flatulent dyspepsia is marked, and the well-known symptoms of intestinal dyspepsia arise. The bowels are irregular, and in the later stages the stools are light in color and show the absence of bile.

With the onset of the enlargement the face is said to become more sallow, and frequently the conjunctivæ are tinged yellow, while a general jaundice may supervene. Of course, if the duration is sufficiently prolonged, as is usually the case, the symptoms of gastro-intestinal catarrh may arise and

hemorrhages from the stomach or bowels take place. Jacobi refers to the frequent absence of symptoms of chronic hyperæmia except short and troublesome breathing after meals or exertion. A dirty-greenish, pale hue of the skin, and the almost œdematous puffiness around the eyes, are seldom wanting. He refers to the observations of Battersby, who calls attention to the condition of the mucous membrane of the stomach by which a morbid over-secretion leads to a voracious appetite known as "pica." The latter writer, quoted extensively by Churchill and many others, observed sixteen cases; and five out of eleven died. The age varied from under one year to seven years. The symptoms do not indicate chronic hepatic congestion, as it is understood at the present day. All the authors who quote Battersby refer to the depraved appetite, observed in seven cases. Cheyne mentions a family in which eleven children died of jaundice associated with enlarged and congested liver. On account of the more accurate pathological knowledge of the present day, clinicians do not lay as much stress on hyperæmia of the liver as they did formerly.

**Diagnosis.**—Active congestion of the liver is of short duration, and is not likely to be confounded with any other hepatic affection. It must not be confounded with acute gastritis or with perihepatitis. Passive congestion of the liver can be recognized by the association of enlargement of that organ with the evidence of cardiac dilatation commonly secondary to disease at the mitral valve, the usual heart-lesion of childhood.

It may, of course, be confounded with amyloid disease of the liver, the characters of which will be pointed out when treating of that division of our subject. Hypertrophic cirrhosis of the liver presents the same uniform enlargement as passive hyperæmia; but the usual presence of jaundice and of ascites early in the history of the case, with the absence of disease of the central organs of circulation, indicates the existence of the former disease. Moreover, the mode of development of passive congestion, the physical characters of the liver, and the occurrence of venous engorgement of other organs, render easy its distinction from hypertrophic cirrhosis.

The enlarged liver of passive hyperæmia is of the same character as the liver of leukemia, an affection which may possibly arise in the course of cardiac diseases. The symptoms of cirrhosis of the liver due to syphilis and enlargement of the organ from that disease simulate those of passive congestion of the liver. But the perihepatitis of the syphilitic liver causes pain, which is absent in passive congestion.

It is to be remembered that the liver of passive congestion may diminish in size, and, if compensation is secured in the heart, the gradual return of cardiac tone may be such as to relieve the venous engorgements. Pathological changes in the liver may arise and a form of cirrhosis develop. The liver becomes reduced in size, and has all the characteristics of cirrhosis. Under such circumstances it is difficult to distinguish this form of cirrhosis from the other forms, or from the syphilitic liver.

**Prognosis.**—The prognosis of active congestion of the liver is good.



Repeated attacks may lead to chronic engorgement, with the establishment of cirrhosis, in the varieties due to intemperance in food and drink; or to grave organic disease. Such attacks in warm climates may induce an abscess of the liver.

The prognosis of passive hyperæmia of the liver depends upon the ability of the heart to regain its lost strength and upon the duration of the disease, as well as upon the presence or absence of an individual tendency—which, no doubt, is seen in some cases more than in others, but cannot be estimated—to an overgrowth of connective tissue. The enlarged liver of passive hyperæmia may, after being under observation for months, return to the normal size and not be followed by cirrhosis. The following case is one of passive congestion of the liver without any cause that may account for it. For this peculiarity the case is worthy of record.<sup>1</sup>

*Tumor of the Liver, Lesions analogous to those of the Cardiac Liver without Disease of the Heart.*<sup>1</sup>—A girl six and a half years old presented herself, April 6, with an enormous development of the belly. Palpation, in spite of the ascites, which seemed considerable, disclosed the fact that the liver was very large and descended to more than a hand's breadth below the false ribs and to some centimetres above the right iliac spine. The subcutaneous veins of the chest and of the abdomen were strongly distended, and marked the obstruction of the portal circulation. There was no œdema of the lower limbs. The general condition was excellent. The patient had a good appearance,—rosy color, no trace of jaundice; she ate well, did not vomit, and had no pain.

No antecedent syphilis was found in the parents, who said that the child had never been sick, and that the rapid development of its belly had begun only two or three months before; however, for a long time it had had a slightly prominent abdomen.

The patient was received in the service of M. Archambault. Examination showed ascites; sharp border of liver felt below umbilicus; on anterior surface, the consistency of which seemed a little firm, no bosses could be found. Difficult to tell whether fluctuation existed or not, for the liver was movable in the ascitic liquid and was displaced by the least pressure.

Urine dark, but containing no more urates than in normal condition. Heart apparently normal; patient never had hemorrhage.

April 8. Puncture of abdomen, to relieve tension and permit a more complete examination of liver. Good-sized trocar used, but only two or three drops of liquid obtained. A second puncture, by M. Rathery, with no more satisfactory result. Fluid obtained had all the characteristics of ascitic fluid. The perfect health of the child led to the opinion that there was a hydatid cyst with ascites by compression.

April 9. Liquid steadily flowed from puncture and infiltrated cellular tissue of abdominal walls. Pressure at the ribs a little painful, but no redness and no heat of the skin. Belly much less distended, no inequalities in the liver, tissue loose, but no fluctuation. Exploratory puncture of the liver at about four centimetres below the ribs, in the middle of the right hypochondrium. No result, and no accident following it.

April 12. Ascitic liquid escapes by the fistulous passages. Skin around them red and hot; infiltrated parts begin to be inflamed. Tongue a little dry, slight fever appears. M. Sabrie thinks there is a hydatid cyst, and recommends a new puncture.

April 15. Two exploratory punctures some centimetres below the first; not a drop of liquid escapes. No accident during the day.

April 17. Inflammation around fistulæ still very acute, belly more tense, violent fever, and vomiting during the day.

April 19. The acute symptoms were due to a phlegmonous erysipelas about the fistulæ, for, as regards the liver, the belly is not painful, there is no tympanites and no peritonitis.

<sup>1</sup> Savard, Bull. de la Soc. Anat., 1880, lv. 291.

April 20. Erysipelas extends to the middle of the back, ecchymoses appear near the groin on the same side; vomiting ceases, replaced by hiccough. Patient sinks into collapse; no longer recognizes its parents. Towards three o'clock the extremities became cold, and death occurred at four.

*Autopsy.*—About three pints of transparent liquid in the abdominal cavity. No adhesions of intestines and no trace of peritonitis. Trace of punctures distinctly seen on peritoneum; Savard cannot explain why liquid was not freely evacuated; trocar penetrated perfectly into serous cavity. No hydatid cyst.

Liver at least double its normal size, of a sombre red color. On section, consistency a little firm, in spots a little jaundiced in color. Subhepatic veins much dilated and contain some large clots, pretty hard, which on section and superficial examination seem to have small lardaceous nuclei. No clots in portal vein, outside the liver, nor in the vena cava.

Microscopic examination shows that the lesions resemble those of cardiac liver. Hepatic cells deformed, flattened, and nearly completely atrophied by the enormous development and distention of the venous channels and capillaries; they are slightly pigmented. These vascular dilatations form the largest part of the mass of the liver; they are filled by blood-globules of exact contour.

**Treatment.**—Theoretically, active congestion of the liver should be treated by means of local depletion. Of course the cause must be removed if possible, and the diet carefully selected to prevent a recurrence. Alcoholic liquors, spices, fat, and rich articles of food must be interdicted. Local depletion by means of cups or leeches over the surface of the liver yields prompt relief; in milder cases mustard plasters may be used; and after such local depletion light flaxseed poultices or a hot-water bag must be applied. Purgatives should be administered,—preferably the salines, which deplete the portal circulation. Phosphate of sodium in small and repeated doses, effervescing draughts of citrate of magnesium, or Rochelle salt may be prescribed.

Of remedial agents the chloride of ammonium is the best. It may be given in doses of from three to five grains every two hours until relief is obtained. Ipecacuanha in small doses is believed to increase the secretions of the liver, as well as to produce an action of the skin, and it may be used in this disease. Anodynes are not to be used, but relief is to be secured, if possible, by the use of the local means and a general warm bath or hot bath.

The treatment of passive congestion of the liver is divided into, first, the treatment of the heart, and, second, the relief of temporary local symptoms. Thus, weight and tension are relieved by means of purgatives. The tendency to sclerosis, which is possible in all cases in which the cardiac force has been renewed, may be counteracted by hygienic and dietetic means. The bowels must be regulated by salines. All forms of food liable to stimulate the portal circulation should be prohibited, and for a long period a diet which scarcely disturbs hepatic functions must be used.

*Bibliography.*—Birch-Hirschfeld, *loc. cit.*; Coats, *op. cit.*, p. 581; Jacobi, A., *New York Journal of Medicine*, January, 1860; Fabre, *Bibliothèque du Médecin-praticien*, etc., 1847, vol. vi.; Battersby, *Dublin Quarterly Journal*, May, 1849; Cheyne, John, *Essays on the Diseases of Children*, Edinburgh, 1801, p. 10, on "Weaning Brash."

## FATTY LIVER.

**Etiology.**—The fatty liver includes fatty infiltration and fatty degeneration of the organ, first described by the older writers. By infiltration is meant the deposition of fat in the tissues. When applied to the liver, the condition may not be truly pathological. In children with active digestion who exercise but little and whose respiration is not vigorous, the carbohydrates are not used up in the economy, and hence infiltration into connective-tissue corpuscles in the organs of the body takes place and the state known as obesity ensues. The causes of fatty infiltration are, therefore, first, an excess of non-nitrogenous oxidizable matter in the portal blood; second, the deoxidized condition of the portal blood; and, third, the low pressure and slowness of circulation in the portal vessels,—conditions unfavorable to oxidation (Bence Jones) and most favorable to the deposition of particles of fat. Fatty infiltration of the liver is met with as a part of general obesity, as indicated above, and in conditions of diminished oxidation, such as occur in tuberculosis. Rich food, deficient exercise or aeration, and the use of alcohol are the prominent causes of fatty infiltration.

The term “fatty degeneration” is properly applied to the process which takes place in the liver, for instance, when the components of the hepatic cells break up and degenerate into fat-particles; this occurs in acute yellow atrophy of the liver and in phosphorus-poisoning. In fatty degeneration due to high temperature the frequency of fatty infiltration compared with that of fatty degeneration is shown by the statistics of Steiner and Neureutter. They are based on a study of two hundred and seventy-two cases. In two hundred and twenty-two of these cases the liver was fatty (one hundred and one boys, one hundred and twenty-one girls). It was amyloid in fifty cases (thirty-two boys, eighteen girls). Of the two hundred and twenty-two cases of fatty liver, fatty infiltration was seen one hundred and eighty-eight times (ninety boys and ninety-eight girls) and fatty degeneration thirty-four times (eleven boys and twenty-three girls).

The conclusions that Steiner and Neureutter arrive at regarding the age and sex of this series of cases, all of which were in children under fifteen years, are similar to the conclusions of other writers. The youngest of the two hundred and twenty-two cases was eleven weeks old, the oldest fifteen years. From the age of one to four it was the most frequent,—one hundred and thirty-one cases; under one year fatty liver appeared in eleven children. The statement of Rilliet and Barthez, that the youngest children were disposed to this far more frequently than the older, was confirmed. This relation is more decided if tuberculous children are separated from the non-tuberculous: one hundred and seven were non-tuberculous; of these a large number (seventy-six) were aged from one to four years. Sex does not have any influence on the development of this condition: one hundred and one boys and one hundred and twenty-one girls were included in the list of cases.

The following table<sup>1</sup> shows the diseases with which fatty liver may be associated :

	TIMES.	BOYS.	GIRLS.
Tuberculosis . . . . .	70	29	41
Enteritis . . . . .	22 [24 ?]	9 [6 ?]	18
Scarlatina . . . . .	23	12	11
Measles . . . . .	22	10	12
Variola . . . . .	17	12	5
Rachitis, with tubercular glands . . . . .	17	12	5
Bone-affections . . . . .	15	7	8
Bronchitis and pneumonia . . . . .	11	5	6
Rachitis . . . . .	8	4	4
Heart-lesions . . . . .	3	1	2
Bright's disease . . . . .	3	..	3
Chronic pleuro-pneumonia with patulous foramen ovale . . . . .	2	1	1
Syphilis . . . . .	2	..	2
Cirrhosis of liver . . . . .	2	1	1
Typhoid fever . . . . .	1	1	..
Burns . . . . .	1	1	..
Erosions of stomach . . . . .	1	1	..
	<u>222</u> [220]	<u>101</u> [103 ?]	<u>121</u> [119 ?]

In many of the cases put down to other diseases there was also tuberculosis of the bronchial glands, which explains the discrepancy between the first statement as to the number of diseases in which tuberculosis existed (one hundred and fifteen) and the figures given in the table.

The above table confirms the statement of all authors that fatty infiltration of the liver is more frequently secondary to tuberculosis than to any other disease, and Legendre, Steiner, Birch-Hirschfeld, and Rilliet and Barthez refer to different series of cases in proof of this opinion. Enteritis is frequently mentioned, and yet it is more than possible that the fatty infiltration and the intestinal inflammation are associated not as effect and cause, but as coincidence.

**Morbid Anatomy.**—The liver is enlarged, flattened, and has rounded edges ; its surface is smooth, shining, translucent, and feels doughy, so that it pits on pressure. The color is reddish yellow or pale yellow, and a dry and warm knife-blade becomes covered with oil-drops if it is drawn through the liver-structure. Frerichs found in one case 78.07 per cent. of fat in a liver after it had been freed from its water, nearly four times the amount of the remaining portions of the tissue. In a fresh condition the same liver contained 43.84 per cent. of fat, and 43.84 per cent. of water, the remainder of the tissue consisting of cells, vessels, etc. The fat consists of olein, margarin, and traces of cholesterin.

The color of the liver depends very much on the amount of blood in the vessels : if it is abundant the color is much darker. On the other hand, it is difficult to distinguish microscopically a fatty liver from one that is

<sup>1</sup> There are evidently typographical errors in the figures of this table.

anæmic. The latter is of the same hue, which, however, is not general, but is distributed in yellow spots which are seen on the surface of the liver, due to pressure of neighboring parts, as the ribs.

Microscopical examination of the liver shows the following changes in fatty infiltration: (1) absence of fat in the intercellular spaces; and (2) deposition of fat in the hepatic cells, which are for the most part rounded and lose their sharp contour. The appearances of the liver-structure in fatty degeneration are similar to those presented in acute yellow atrophy of that organ.

**Symptoms.**—Symptoms of fatty liver are not special. Either the disease which is associated with the degenerated liver presents its own symptoms, or only the symptoms and conditions which arise in children of sedentary life, who take rich food,—such as the symptoms of indigestion and the general state of obesity,—are found.

Betz includes in the symptomatology of fatty liver the following series of phenomena, which he admits may occur in fatty nutmeg-liver, and the last of which, it is seen, may be due to, or actually are the causal factors in the production of, the fatty liver. They are (*a*) emaciation; (*b*) hectic fever; (*c*) a withered, fine velvety, pale yellow, anæmic skin; (*d*) the above with or without one of the following forms of disease: tuberculosis; carious and carcinomatous processes, connected with imperfect oxidation of the blood; chronic intestinal catarrh; rachitis; alcoholism. The latter is rarely found in children.

The urine has been studied by Horaczek,<sup>1</sup> who believes that a variegated rainbow-colored pellicle is found on the urine in fatty liver. Betz says that in true fatty liver the formation of urea, uric acid, and urine-pigment must be lessened more than in a fatty nutmeg-liver. He thinks that the appearance of a pellicle on the urine may support the diagnosis, but that of itself it has no value.

The recognition of fatty liver depends chiefly upon the physical signs determined by inspection, palpation, and percussion. Not generally is the liver seen to be enlarged, nor are the lower ribs usually prominent, but an abnormal fulness of the epigastrium is common. On palpation the surface of the enlarged liver is smooth and free from pain. The border of the liver is thick and even. The surface presents the same degree of resistance as in health, and hence the borders cannot be so well palpated. On percussion the liver is found to be enlarged uniformly in all directions. The increase in dulness is more marked in the epigastric region. It is important to remember that the splenic dulness is not increased, but even may be diminished, while the absence of jaundice and ascites may be noted. If jaundice should occur, it must be due to an accidental cause, and in children most likely to a gastro-duodenal catarrh.

Horaczek considers hereditary predisposition most significant for pur-

---

<sup>1</sup> Schmidt's Jahrbücher, Bd. xlvi. S. 303.

poses of diagnosis. Of course this implies a knowledge of the tendency to the special tissue-changes of the family to which the patient belongs.

It is to be remembered that fatty liver may exist without any noteworthy attending disease, and even without any disturbance save that caused by its size, such as pressure upon the right side when lying on the left. The absence of symptoms should not, therefore, exclude the diagnosis of fatty liver.

The origin and occurrence of the fatty liver, as well as the ultimate changes it may undergo, are of interest. Its occurrence in the first years of life has been referred to. There are observations sufficient to show an intra-uterine origin. Senlen describes the case of a dead-born child, nine months old, the father of which suffered with jaundice and dropsy. The liver of this child weighed one pound and nine ounces, and was fatty.<sup>1</sup> Frerichs found fatty liver in new-born children and in children a few weeks old.

Betz well shows that we know practically nothing concerning the beginning of and concerning certain changes in this disease. He thinks variations in volume should be observed in fatty liver, and he warns us how easily we can be deceived in determining its changes. That they do take place there is no doubt. They are not temporary retrogressions or cessations in the fatty metamorphosis. Whether or not the fatty liver of childhood can remain latent or stationary up to adult life and then develop rapidly, we do not know. He thinks a recovery is inconceivable if the degeneration of the liver-cells seen in fatty hypertrophy is present. Apparently in some cases the liver takes on retrograde changes and gradually becomes cirrhotic. The writer recently had under observation a patient who had a very large fatty liver. It diminished under observation. Death took place from acute disease, and the liver was found to be cirrhotic.

Steiner and Neureutter relate the case of an eleven-months-old child, of healthy parentage, which had tuberculosis accompanied with enlargement of the liver. At the autopsy the changes of rachitis, anæmia, and double pneumonia were found, and the tissues were intensely jaundiced. The liver was enlarged. Shallow depressions on its upper surface were seen. On section the structure was stained with bile, and was fatty and doughy. The bile-ducts were pervious, and the gall-bladder contained clear, watery, viscid fluid. From the description one would not think this a case of cirrhosis.

A second case appears to prove more fully their belief that the decomposition of fatty infiltrated cells and resorption of the fat may result in a kind of granulated liver. A little girl, five and a quarter years old, in poor circumstances, was admitted to the hospital, with cough and diarrhœa; she was emaciated, had enlarged glands, tuberculosis of the lungs, and enlarged liver. Dropsy and sweats developed, and death followed. Tuberculosis was found at the autopsy. The liver was much enlarged, its border rounded, the upper and lower surfaces deepened in places and scarred. The

---

<sup>1</sup> Schmidt's Jahrbücher, Bd. vi. S. 96.

color of its surface was clear yellow, spotted with bile, and red in places. On section the surface was of an intense grayish yellow, firm, the acini were recognized only in discrete red spots of indented form, and the capsule was the seat of inflammation.

**Diagnosis.**—The diagnosis of fatty liver is usually made by exclusion. If in the course of tuberculosis or the associate diseases already mentioned one finds an enlarged liver, with all the characteristics indicated in the symptomatology, and without hepatic symptoms or enlargement of the spleen, the affection is in all probability fatty infiltration of the liver. The absence of albuminuria and polyuria, the absence of enlargement of the spleen, and the differences in the physical characters of the respective forms of liver-enlargement, exclude amyloid disease of that organ. Much importance has been attached by writers to the concurrence in fatty liver of similar degeneration in the heart and the kidneys when this affection is found in adult life. The conditions which favor these changes in the heart and kidneys of adult life do not obtain in early childhood, and hence we do not expect to find them. Indeed, frequently they are simply the changes which come with the normal changes of the aging process.

Fatty degeneration of the liver, as indicated in speaking of the etiology, is secondary to grave general or local processes, does not cause enlargement of the liver, and hence does not call for discussion in this section.

**Prognosis.**—The prognosis depends upon the associated phenomena, as tuberculosis or other general disease. In the fatty liver which results from errors in diet or from lack of exercise, if the conditions are controllable, the prognosis is favorable.

**Treatment.**—The treatment of fatty liver implies a treatment of its cause, the methods of which are obvious from a knowledge of the etiology, —namely, alteration of the habits of the child, and, if necessary, change to a climate which will admit of constant exercise in the open air. Farinaeous, fatty, and saccharine articles of diet are to be excluded, as well as alcoholic liquors. It is said that cod-liver oil must not be used when fatty liver is present, even if the drug is indicated for the primary disease. The medicinal treatment must be directed mainly to correction of the digestion and regulation of the bowels. The use of alkalies and alkaline waters has been recommended, and, if practicable, a course at Carlsbad or Vichy, or at springs of like nature in this country, may be advised.

*Bibliography.*—Betz, Friedrich, *Memorabilien*, 1876, xxi. 385; Steiner and Neureutter, *Jahrbuch für Kinderh.*, Bd. vii., Wien, 1865; Vogel, *Lehrbuch der Kinderh.*, 179; Green, *Pathology*, 6th (Amer.) ed., p. 61; Starr, L., *Therapeutic Gazette*, 1887, 3d s., iii. 73.

#### AMYLOID LIVER.

Amyloid, albuminoid, or lardaceous degeneration of the liver is one of the most frequent forms of painless enlargement that occur in childhood. It is not a disease that is confined to the liver alone, the spleen, the kidneys, and the intestines being likewise affected.

**Etiology.**—This degeneration, like fatty degeneration, is also secondary to tuberculosis, as well as to chronic bone- or joint-disease (usually tubercular), syphilis, and most frequently to prolonged suppuration or any purulent discharge. Empyema is one of the most frequent of the last of the four general causes indicated which give origin to this affection.

Steiner and Neureutter have detailed forty-seven cases of amyloid disease of the liver, divided as to cause as follows :

	BOYS.	GIRLS.	TOTAL.
Caries, with or without tuberculosis of lymph-glands . . . . .	9	3	12
Lymph-gland tuberculosis . . . . .	4	2	6
Hereditary syphilis . . . . .	2	1	3
Tuberculosis of lymph-glands and other organs . . . . .	4	1	5
Rachitis and lymph-gland tuberculosis . . . . .	1	1	2
Chronic eczema . . . . .	2	..	2
Chronic pneumonia . . . . .	1	1	2
Psoas abscess . . . . .	1	..	1
Croupous laryngitis . . . . .	1	..	1
Noma after measles . . . . .	..	1	1
Variola . . . . .	..	1	1
Pleurisy . . . . .	1	..	1
Rachitis . . . . .	..	1	1
Amyloid liver and spleen, with or without Bright's disease . . . . .	5	4	9
	31	16	47

Frerichs found, in fifty-three cases, three under ten years, and nineteen between ten and twenty years of age ; and in Wagner's forty-eight cases, five were under ten and five between ten and twenty. Descroizilles says that it is met with especially between the ages of ten and twelve, and in boys oftener than in girls. Birch-Hirschfeld considers it to be most frequent in children from four to fifteen years of age. All agree that the affection is of frequent occurrence, and yet the literature of the disease does not contain the reports of many cases.

**Morbid Anatomy.**—The amyloid liver is the seat of general enlargement. Its structure is heavy and dense, the capsule is clear, and on section the cut surface is dry and homogeneous, of a gray color and a glistening appearance. The edge of the liver is rounded. It is almost bloodless on section. The seat of the disease is usually seen to be in the periphery of the acini, the edge of which is light or white. The change usually begins in the walls of the capillaries and arterioles of the hepatic artery, rarely, it is said, in the capsule of the portal vein ; thence the deposit spreads to the intra-acinous connective tissue round the affected vessels, ultimately reaching the tissue between the lobules and leading to confusion of their outlines. The connective tissue swells into homogeneous columns, which split readily into flakes like hepatic cells, and which on section look like a mass of degenerate cells or often like whole lobules ; careful examination will, however, reveal between the lardaceous masses the liver-cells more or less atrophied and pigmented, the external cells of the zone especially being infiltrated with fat.



The division of the lobule into zones, and the fact that the external zone is the seat of amyloid degeneration, are well known. The internal zone of fatty degeneration and the middle zone of congestion serve to distinguish these forms of hepatic disease anatomically. The iodine test, which causes the parts affected to become a reddish brown when it is applied to a small portion, and the sulphuric-acid test, which changes the affected tissue to a violet and afterwards to a blue color, distinguish this affection.

Of the nature of amyloid degeneration we are not quite certain. It seems that there is primarily an alteration in the blood; probably there is a diminution of the normal mass of albumen. Some think, however, that the tissues are reduced in vitality by the altered condition of the blood, and that the albumen received enters into combination with the protoplasm in such a way as to produce the peculiar substance. Coates, to whom we are indebted for this statement, says the process may be compared to the coagulation of the tissues which sometimes occurs when they undergo necrosis. The tissues apparently enter into chemical union with the fibrinogen in the fluid exuded from the blood-vessels, so as to form fibrin or some substance allied to it. It is essentially a degeneration, but with the addition of tissue from without. Green says that in children especially—though very rarely, it is true—the degeneration may seem to be primary.

Amyloid substance, or lardacein, is an amorphous, white, friable substance that appears to be a fibrin derivative. It occurs only as a pathological product, and in the liver as an infiltration. It is insoluble in water, alcohol, ether, dilute acids, and the alkaline carbonates.<sup>1</sup>

It may not be out of place to indicate the course of amyloid disease in childhood by reference to one of the best reported cases on record, before discussing the symptoms. Pilz details the history of a girl thirteen years old who is said to have been well until her fifth year, when a suppurating of the dorsum of the left hand developed. It continued, and in the course of time a fistula of the rectum appeared. From the eighth year a hardness was noticed in the right hypochondrium. Œdema of the ankle and foot had occurred at intervals two years before. During this time the special symptoms were repugnance to meat food and frequent attacks of diarrhoea, the stools having the odor of carrion.

When admitted to the hospital, the patient assumed a dorsal position; she had a pale, waxy-hued skin, and a marked net-work of veins on the abdomen; the extremities were œdematous, the skin dry, the belly much swollen, with marked undulation; the circumference at the navel measured seventy-eight centimetres, and between the xiphoid and the navel seventy-nine centimetres; while the distance between the xiphoid and the navel was twenty-nine centimetres. The liver in the middle line measured fourteen centimetres, and reached beyond this line to the left eighteen centi-

---

<sup>1</sup> Charles, *Physiological and Pathological Chemistry*, p. 120.

metres. In the mammary line it measured nineteen and a half centimetres, and in the axillary line twenty-three and a half centimetres. There was decided ascites. The urine amounted to six hundred cubic centimetres, had a specific gravity of 1016, was acid, and contained much albumen.

During the time she was under observation, there were bloody vomiting, bloody stools, increase in dropsy, and profuse discharge of pus from the fistula, which resulted in exhaustion and death six weeks after admission. Pilz states that while under observation the pulse was steadily accelerated: on May 23 it was 90, on August 1, 80 to 86, on August 2, A.M., 68; and at other times it was above 100,—on the average between 110 and 120 beats to the minute. It was also small. The respirations were accelerated and shallow, between 36 and 46, rarely 56. The temperature in the axilla varied between 98.6° F. and 100.4° F., and therefore was never lowered, as Taylor has suggested is the case in amyloid disease of the kidneys.

The body-weight of the child on July 13 was fifty-three pounds and five ounces, and on July 27 fifty-seven pounds and seven and a half ounces. This increase in weight was due mainly to the increased transudation.

*Autopsy.*—Liver adherent in great extent to the diaphragm, weight six pounds and eleven ounces, appearance that usual in amyloid disease of the liver. Pilz remarks upon the relative weight of the liver and that of the body,—six pounds and eleven ounces to fifty-seven pounds and seven and a half ounces, or as one to eight and a half. He says that in cases known to him this weight has been surpassed in absolute weight only by one of Steiner and Neureutter's cases, in which, in a thirteen-year-old boy with suppuration of the right psoas muscle, the liver weighed seven pounds and ten and a half ounces, and in proportional weight only by a case observed by Murchison, in which a boy with suppuration of bones had a liver weighing sixty-nine ounces, which was one-seventh of the body-weight. The disproportion in weight is still more striking when the normal relation is given, which, according to Frerichs, is for the eleventh year 1 to 25.56, while with a body-weight of twenty-five thousand and eighty grammes the liver weighs nine hundred and seventy grammes. Pilz compares the size of some enlarged livers with that in the amyloid cases just given, and shows the great preponderance of the latter. It is worthy of note that there was also some fatty change, especially in the periphery of the lobules, besides a great development of connective tissue between the lobules,—associated pathological changes which are frequently found with this affection.

*Symptoms.*—The rather full abstract of the case just quoted was given in order to indicate the usual course and symptoms of this disease. In general it may be said that the symptoms are of three kinds,—(1) the general symptoms or cachexia due to the amyloid change; (2) symptoms of amyloid disease in other organs; (3) symptoms due to enlargement of the liver,—in other words, mechanical.

Of course the symptoms depend upon the primary disease very largely, and this is notably true with regard to the cachexia. If the causal disease

has a cachexia of its own, the amyloid cachexia is not so pronounced, although the general symptoms—that is, emaciation, prostration, and general pallor or anæmia—are more grave and more rapid when amyloid degeneration begins. If the underlying disease has no cachexia, we see with the commencement and development of amyloid disease increased pallor. The skin becomes of a pale white or waxy hue. Anæmia is marked, and local and general œdema, followed by general anasarca, soon arises.

The most important symptoms of local origin are due to enlargement of the liver. On inspection, the marked bowing of the lower part of the right thorax and great fulness in the upper abdomen can be readily seen. By palpation, if emaciation exists or if great meteorism or ascites does not interfere, the lower border of the liver can be felt. The edges are rounded and firm. The surface of the organ is smooth, and the normal fissures are deepened. Pressure does not cause pain, unless a perihepatitis exists simultaneously, as may occur in syphilis. On account of the enlargement, the respiration is usually quickened, but is regular. The heart's action is increased in frequency, while as the disease progresses it becomes enfeebled. The veins over the abdomen are sometimes dilated, though rarely, and never to the same extent as in cirrhosis.

Associated with this disease in the liver, similar disease almost always develops in the spleen and the kidneys, and probably in the gastro-intestinal tract. The spleen becomes enlarged, and thereby increases the size of the abdomen, and hence interferes with respiration and circulation. With the involvement of the kidneys albuminuria is found, polyuria is marked, and the urine is of the low specific gravity of this disease. Casts are found on microscopical examination. With the development of the disease in the kidneys, dropsies, which may occur without it, are likely to be found. Ascites, notably absent in uncomplicated amyloid disease of the liver, is present, while œdema of the face, the feet, and the hands also arises. The failing circulation favors the occurrence of these dropsies.

The gastro-intestinal symptoms are usually marked. It is particularly noted by some that the patient has a special aversion to meat but otherwise has a very good appetite. In other cases a desire for food is much diminished, nausea is marked, and vomiting is a common symptom. The intestinal functions are also disturbed: more or less meteorism occurs, while diarrhœa is most usual. The stools are brownish yellow and foul-smelling. The carrion-like odor of the stools has been frequently remarked by writers.

Frerichs found in twenty-three cases of amyloid liver simultaneous enlargement of the spleen fourteen times, in some instances with amyloid degeneration of that organ. The diarrhœa in the later stages becomes most obstinate, and is dysenteric in character. While so prominent a symptom, and apparently indicative of extreme organic change in the intestines, yet a post-mortem examination always reveals no evidence of inflammation of the bowel.

The duration of amyloid disease of the liver cannot be determined,

because the first stages escape observation. Birch-Hirschfeld states that it is not always uniformly progressive, and that the hydræmic symptoms often disappear for a long time and the local symptoms may become milder. The anæmia is not wont to lessen. Death may be due to the primary disease, to local or general dropsies, to exhaustion following uncontrollable diarrhœa, or to the complications, as peritonitis and pleurisy.

The *prognosis* is very unfavorable when the symptoms are so distinct that a diagnosis can be made.

The *diagnosis* of amyloid disease of the liver is not usually difficult when the disease is fully developed. The cachexia, the enlarged smooth hard liver of uniform size and without pain, associated with enlargement of the spleen, albuminuria and polyuria developing in the course of tuberculosis, syphilis, or chronic suppuration, make up a picture not difficult to recognize.

**Treatment.**—1st. Treatment of the primary disease if possible.

2d. The use of a nutritious diet easily digested, associated with a moderate amount of stimulants.

3d. Residence in a mild and equable climate.

4th. The use of medicines which may possibly influence the chemical changes which take place in amyloid disease. Of these the most prominent are the alkalies. Dr. Dickinson urges their use. He thinks the salts of potassium which are administered compensate for the discharge and prevent amyloid disease. He prescribes a mixture containing the liquor potassæ with the phosphate and citrate of potassium and tartrate of iron.

Tonics, of course, are to be used, and, on account of the profound anæmia, one would expect service from the various preparations of iron. Murchison has seen marked improvement under the continued use of nitric acid in combination with a vegetable bitter. He recommends the external use of nitro-muriatic acid over the liver. Frerichs states that during the long-continued use of cod-liver oil amyloid disease has developed. Its value, therefore, is questionable. Iodine has many advocates, and it or its preparations would undoubtedly be of service when there is a clear syphilitic history. For similar reasons mild doses of the bichloride of mercury may be used. Wetzlar recommends the mineral waters and baths of Aix-la-Chapelle. Begbie advises the use of the chloride of ammonium in large doses. He has observed a great reduction of the size of the liver, and Budd has observed cases where marked improvement occurred when the carbonate or chloride of ammonium was used.

The therapeutic skill of the physician is more strongly taxed in the treatment of the complications of this affection than in the treatment of the disease in general. In spite of the best therapeutic measures, the symptoms often are uncontrollable. The diarrhœa, for instance, while astringents both mineral and vegetable may be used, with or without opium, and the diet regulated, will sometimes resist all treatment and cause the patient's death. Persistent vomiting likewise is most difficult to control.

Careful feeding, the use of preparations of pepsin, of alkalies, of bismuth, and of hydrocyanic acid, and external counter-irritation, are to be tried.

The dropsy, too, is very difficult to treat. The diuretic preparations and combinations of the salts of iron are of the most service, though they are difficult to use if the stomach is irritable; when this is the case, the salts of potassium that act on the kidneys may be given, preferably in effervescence. Purgatives must be given with caution, on account of the natural tendency to diarrhœa. Drugs which stimulate the circulation are to be used. Digitalis, if borne, is a most valuable diuretic and tonic. Cocaine in small doses meets two indications: it is often excellent to relieve vomiting, and at the same time is a good diuretic. The salts of caffeine may be used for a similar purpose. As remarked above, the association of such pronounced complications causes a group of symptoms which it is almost impossible to overcome.

*Bibliography.*—Murchison, Diseases of the Liver, p. 39; Meigs, A. V., Archives of Pediatrics, 1887, iv. 222; Pilz, C., Jahrbuch für Kinderh., 1870, iii. 29-45; Charles, Physiological and Pathological Chemistry; Coats, Manual of Pathology, p. 134; Descroizilles, *op. cit.*, p. 259; Trans. Path. Soc. Lond., vol. xiii. *passim*; Frerichs, *op. cit.*, vol. ii. p. 190, ff.; Begbie, Reynolds's System of Medicine.

#### HYDATID DISEASE OF THE LIVER.<sup>1</sup>

Hydatid disease of the liver is produced by the development within the liver of the *tenia echinococcus* in its larval condition. The life-history of this tape-worm has been very carefully studied, and whoever is interested in the subject will find full descriptions of the parasite in the writings of Leuckart, Cobbold, and Davaine: it will be sufficient for our purposes, however, to state that the adult tape-worm is found in the small intestine especially of the dog, and that the minute eggs, passing out with the dog's fœces, are swallowed with the food and drink by human beings, as well as by a number of other animals. When the eggs are thus swallowed, their shells are dissolved, the embryos thus become liberated, penetrate the mucous membrane of the bowel, and may travel to any part of the body; but from the greater frequency of hydatid disease in the liver it has been inferred that the embryos preferably enter the portal vein or its branches, and so are carried in the blood-current to the liver. Wherever the embryo becomes fixed in position it becomes the point of origin of a hydatid tumor.

**Frequency.**—It is self-evident that the longer a person is exposed to the danger of swallowing eggs of the *tenia echinococcus*, the greater will be the probability of his contracting hydatid disease. For this reason the frequency of the disease increases, as Thomas has admirably demonstrated, with every decade up to fifty, when it falls, because there are fewer alive to become infected. But while children, for the reason just given,

---

<sup>1</sup> For this division of the general subject of enlargements of the liver, the author acknowledges his indebtedness to his friend and former student, Dr. Herman B. Allyn.

are much less likely to have the disease than adults, they are by no means exempt from it.

Hydatid disease is found in almost every country about which we have accurate medical knowledge. It is not influenced by climate, for it is especially prevalent in Iceland and in Australia, and it is not uncommon throughout the northern portions of Europe. Intimate association with dogs, coupled with lack of care to see that the water and food are not contaminated with the eggs of the parasite, no doubt accounts for the prevalence of the disease in Iceland and Australia. It has been estimated that in the former country one-seventh of the population has the disease. Dr. John Davies Thomas has shown that the disease plays a very important part in the mortality of Australia, and he gives some surprising and interesting information concerning the wide area of distribution of hydatid disease throughout the world.

Hydatid disease is almost unknown among native-born Americans. Dr. Osler has been able to collect records of only sixty-one cases in America, a third of which probably occurred in foreign-born persons, leaving only forty native cases. Only one of the sixty-one cases was in a child. It would appear that our immunity from the disease is to be explained by more careful habits of living, since Osler has demonstrated that the adult echinococcus is found in dogs and other animals in this country more frequently than is commonly supposed, and it is a matter of common knowledge that there are large cattle- and sheep-ranches in the western and southwestern sections of the United States.

There is reason to believe, also, that it is not so rare in children as many writers have asserted. Birch-Hirschfeld found twenty-seven cases of hydatid disease of the liver in a review of the literature, which he states was by no means complete; and he says that Finsen has found forty-one cases in Iceland in persons under fifteen years of age, and Thorstensen has recorded twenty-six cases in children under ten. Thomas, in his table of five hundred deaths from hydatid disease occurring in Victoria between the years 1868 and 1881, records thirty-six cases in children under ten years of age, and fifty-seven between the ages of ten and twenty; in New South Wales the number of deaths in persons under twenty years of age, between 1875 and 1881, was thirteen; in Queensland there were two deaths between 1878 and 1881, and in South Australia there were seven between 1866 and 1882. This gives a grand total of one hundred and fifteen fatal cases in persons under twenty years of age. Of course in the majority of these cases the liver was the seat of the disease. No record is given of cases in which recovery occurred. The writer has been able to collect, from French, German, and English sources, records of thirty-three cases of hydatid disease of the liver in children of fifteen years or under, exclusive of Thomas's cases. It is evident, therefore, that the disease is not one of extreme rarity in children.

Moreover, the slowness with which the disease develops makes it prob-

able that many of the cases first recognized in adults began in the period of childhood. Budd mentions a remarkable case in which a woman who died at seventy-three was found to have two hydatid tumors, which there was reason to believe had existed since she was eight years old. Barrier<sup>1</sup> mentions a case in which the duration was from fifteen to thirty years, and a number of cases are on record in which the duration has been from two to six years.

**Anatomical Characters.**—When the hydatid embryo becomes fixed in position, it loses its hooks, grows larger, and from a solid body becomes gradually transformed into a vesicle,—the hydatid cyst. The capsule of this cyst is a connective-tissue membrane formed from the human tissues, apparently as the result of the irritation induced by the presence of the parasite. It is, therefore, no part of the cyst proper. The thickness of the capsule is variable, and probably increases the longer the parasite remains in the body of its host. It is richly supplied with blood-vessels, which nourish both it and the contained parasite; fatal hemorrhage has resulted from rupture of the vessels upon the internal surface. The capsular walls are subject to the same degenerative changes that affect other tissues, but especially to calcareous degeneration.

Within this capsule is found the parasite, transformed into a cyst. The outer wall of the cyst is translucent, lamellar, and very elastic; the inner wall is composed of granular matter, cells, muscle-fibres, and vessels. The fluid contained in the cyst is translucent, and faintly opalescent in transmitted light. It is almost entirely free from albumen, but contains salt in large quantity, abundance of leucin and tyrosin, some grape-sugar, and succinic acid. The latter, Leuckart states, is found in hardly any other living organism. The fluid also contains crystals of cholesterin, and sometimes hema-toidin,—the latter when hemorrhage into the sac has occurred. The specific gravity of the fluid is placed as low as 1000 by Frerichs, but it probably varies between 1009 and 1015.

Three varieties of hydatid cyst have been described,—first, *Echinococcus granulosus*; second, *E. hydatidosus*; and, third, *E. multilocularis*. In the first variety there is a simple cyst the internal layer of which contains brood-capsules, developed by a budding process from it. These brood-capsules contain the heads, or scolices, of the parasite. The capsules may rupture and allow the heads to float free in the cystic fluid; but in the normal fresh condition they are attached to the cyst-wall. This variety is most frequent in domestic animals, though it also occurs in men.

The second variety, *Echinococcus hydatidosus*, is characterized by the formation of daughter-cysts in the interior of the mother-cyst. The daughter-cysts may be developed in large numbers, even to the number of thousands, and may in turn give rise to grand-daughter-cysts. The continued proliferation of these cysts accounts for the large size of the tumor.

---

<sup>1</sup> Quoted by Birch-Hirschfeld.

Naunyn and Leuckart assert that the daughter-cysts are produced by a retrograde metamorphosis of the heads and brood-capsules. In the case of echinococci which are destitute of heads, it is supposed that the daughter-cysts are produced by a sacculation of the echinococcus wall.

The third variety of echinococcus, *E. multilocularis*, is believed to result from an abnormality of development. It is made up of a large number of very small cysts, closely set, and containing transparent, jelly-like material. The alveolar arrangement visible on section, and the gelatinous character of the contents, led to the belief at one time that they were tumors which had undergone colloid change. To the touch this variety of cyst is firm and resistant; it grows to the size of the fist or to that of a child's head, is comparatively rare, is found almost exclusively in man, and in him almost invariably in the liver.

The three varieties described are simply forms of the same species. The *E. hydatidosus* attains the largest size, is the one most frequently met with, and is consequently the most important from a clinical point of view. Of course more than one form may be met with in the same person.

**Symptoms.**—The symptoms of hydatid disease of the liver up to a certain point are neither many nor characteristic. The growth of the tumor is slow and imperceptible. Sometimes it is detected only by accident, or when the patient is under examination for some other ailment. The latter was the case in the instance related by Thieberge. A boy six years old, suffering with croup, was found to have two hydatid cysts of the liver. The existence of one of these had been noted by the parents, but neither appears to have given rise to any symptoms. The boy died from extension of false membrane into the bronchi, and the clinical diagnosis was established by the post-mortem examination.

In other cases the existence of a hydatid tumor has been unsuspected until the child has sustained some injury, as in the case reported by Edge. A boy four and a half years old was forcibly grasped around the waist and lifted from the ground by a playmate. He ran home complaining of pain, and his mother found a swelling in the abdomen. Two days later a hydatid tumor the size of an orange was discovered.

The local symptoms of hydatid tumor of the liver depend upon the seat of the tumor and upon its size. A small tumor situated so as to compress the bile-ducts or the blood-vessels will give rise to jaundice and to vascular symptoms. In a case cited by Pontou, from the service of Triboulet, a girl twelve years old had an enormous liver, filling the right hypochondrium and extending to the iliac fossa and all the sub-umbilical region. The tumor had the physical characteristics of an hypertrophied liver. To increase the difficulty in diagnosis, pressure over the liver was painful, jaundice was present in a marked degree, and there were repeated copious hemorrhages from the nose, and, later, dropsy. At the autopsy there was found an enormous cyst situated behind the liver, and replacing the whole right lobe, except a wall of hepatic substance. In front of this tumor, in the



fissure of the vena cava, was another cyst. It was the latter which caused the jaundice and dropsy. But neither jaundice nor ascites is a common symptom.

The most common seat of hydatid disease of the liver is in the right lobe, near its anterior surface. Ponton says that in the cases accurately reported the parasite occupied the right lobe seven times and the left lobe three times, while in four cases it was on the anterior surface and twice on the posterior. It will be readily understood that a tumor of moderate size situated upon the anterior or convex surface of the liver would be detected, whereas if situated on the posterior surface of the liver, or between the liver and the diaphragm, or between the liver and the stomach, it might not even be suspected, especially as subjective symptoms are frequently absent. In Unterhart's case, in a girl nine years old, the cyst developed on the posterior surface of the liver at its upper edge, and pushed the diaphragm up and the liver down. In the first attempt at puncture the trocar struck the liver, but subsequently the cyst was pierced at a point in the nipple line, where there was no prominence.

Sometimes the cyst projects from the inferior edge of the liver as low as the umbilicus, or into the right iliac fossa. At times it develops in the body of the liver, and the dimensions of the latter become enormously increased, the belly is conspicuously swollen, and the edge of the ribs is expanded like the rim of a bell. The subjective symptoms in such a case may be a sense of tension and discomfort in the liver region, with perhaps pain and tenderness if the capsule of the liver is much stretched or if peri-hepatitis coexists. There may also be digestive disturbances, such as constipation, vomiting, lessened appetite, and some loss of flesh. On the other hand, there may be no symptoms except the local ones, and the general health may remain good.

Such a case as the latter statement suggests is recorded by Petel. A boy three and a half years old was brought to Archambault's clinic for an enlargement of the abdomen which had been noticed for a year and had developed gradually. The child had had neither diarrhoea, vomiting, nor jaundice; it had never complained of its belly, and its general health remained good. The belly below the false ribs projected, and palpation disclosed the presence of a tumor situated in the liver. The tumor was round, smooth, and painless, and in volume about the size of a fetal head. It appeared to be embedded in the right lobe of the liver, and was hard and resisting, presenting neither fluctuation nor vibration. At its most prominent part, however, it exhibited a sort of elasticity which gave the impression that the tumor contained liquid. The child presented no digestive troubles, no œdema of the limbs, and no ascites. The tumor was aspirated and hydatid fluid withdrawn.

It will be seen that in such a case the symptoms, while entirely local, are still sufficient to make a diagnosis.

When the tumor is developed near the surface of the liver and is of

considerable size, or when it projects below the liver in such a way that it can be examined through the abdominal walls, it is usually possible to obtain fluctuation, and in a number of cases the so-called "hydatid fremitus" can be developed. This fremitus is nothing but the vibration transmitted to the examiner's hand by sharply tapping a tense thin-walled cyst filled with fluid. To develop this sign, Murchison advises that the three fingers of the left hand be laid flat upon the tumor, and the back of the left middle finger then struck abruptly with the point of the middle finger of the right hand. It was at one time taught, especially by the French writers, that this fremitus was caused by daughter-cysts striking and rebounding from the wall of the mother-cyst; but it may be felt in simple cysts and is entirely independent of the existence of daughter-cysts. Küster relates a case, in a girl nine years old, in which hydatid vibration was very decided. During a radical operation for the removal of the cyst, it was found that only two mother-cysts, bordering on each other, existed, and no daughter-cysts. Küster regards the discovery that two or more adjacent mother-cysts may give rise to hydatid vibration as noteworthy for operative reasons; as, in cases in which the sign has existed and upon operation no daughter-cysts are found, contiguous mother-cysts should be sought for and evacuated.

Up to a certain time, therefore, a hydatid cyst, of moderate and even of large size, may persist without any subjective symptoms and with few if any local physical signs. Sooner or later, however, symptoms appear, from the pressure exerted by the enlarging tumor, and from the resulting interference with the function of the liver and with surrounding viscera. Birch-Hirschfeld states that after the favorable general condition—which is all the more striking in contrast with the demonstrable tumor—has lasted for a long time (generally a year), emaciation usually begins, the skin simultaneously becomes increasingly pale, and digestive disturbances appear. Sometimes at this stage hydræmic symptoms begin. Gerhardt maintains that emaciation is wont to occur more quickly in children than in adults.

While pain over the liver and fever are usually absent, they occur in some instances as the case progresses. In the case related by Stromszky, a boy eight and a half years old applied for treatment on account of frequent stabbing pains in the right hypochondrium, in which region a swelling had been noted for six months. The liver was enlarged and projected two finger-breadths below the edge of the ribs. During the succeeding few months the symptoms consisted of gastric disturbance, obstinate constipation, pains in the abdomen, and fever. As the liver slowly enlarged, the symptoms became more marked, and there were added to those already mentioned headache, loss of appetite, troublesome swelling of the abdomen, and so bad a general aspect that typhoid fever was suspected. The subsequent symptoms in this interesting case may be briefly mentioned, for they illustrate the effects of the gradually-increasing pressure of a tumor of the liver upon the circulation, respiration, and general nutrition of the

child. The child lost flesh, and became increasingly pale; with the progressive enlargement of the liver, the belly steadily increased in size until it measured eighty-four centimetres in circumference and the distance from the xiphoid cartilage to the symphysis pubis was thirty-nine centimetres. Thick bluish veins appeared about the navel and extended upward to the middle of the thorax and beyond on the right side. Œdema occurred, and some dyspnoea; subsequently the œdema increased, ascites developed, gangrene of the scrotum set in, and respiration became increasingly embarrassed. Fever was continuous during the later stages, and death resulted from exhaustion about fifteen months after the swelling over the liver was first noticed. An autopsy confirmed the diagnosis—arrived at late—of hydatid disease of the liver.

But, apart from the pressure-symptoms arising from the gradual development of a hydatid tumor, which are so well portrayed in the case just cited, special symptoms occur from rupture and from inflammation and suppuration of the sac. Rupture took place in one-third of the four hundred and fifty-one cases of hydatid disease of the liver collected by Neisser. It occurred as follows: into the alimentary canal in forty-five cases, into the bronchi after perforation of the diaphragm in thirty-one cases, into the peritoneal cavity, into the pleura, and externally, in sixteen cases each. Rupture occasionally occurs also into the veins, ureters, and bile-ducts.

The symptoms following rupture of a hydatid cyst into the peritoneal or pleural cavity are those of acute suppurative peritonitis and empyema, and need not be dwelt upon in detail. Death is the usual result. When rupture into the intestine occurs, the fluid and daughter-cysts may be discharged by the bowel; though if the fistulous communication with the intestine is high up, they may be vomited. As a rule, however, the cysts are ruptured before being discharged, and only shreds of membrane, which require the microscope for their proper recognition, appear in the stools. If rupture occurs into the veins, the symptoms are those of phlebitis, or thrombosis, or local gangrene. When rupture occurs externally, a fistulous communication with the sac is established, through which the contents of the cyst are gradually drained. Of course, as the result of this fistula, suppuration of the sac may occur, and peritonitis develop later. When rupture occurs into the bronchi, the fluid and cysts or shreds of membrane are expectorated, and recovery is the rule.

Suppuration of the cyst occurs in some cases, and may be discovered before tapping or not until afterwards. In a case reported in the thesis of Pontou, from the service of Giraldes, suppuration of the sac was discovered when the cyst was incised, and after death there were found metastatic abscesses of the liver. While the pus is confined to the sac, there may be no symptoms in addition to those already mentioned, since the cyst is practically outside the body so far as connection with the circulation is concerned. But if adjacent structures are inflamed, or pus leaks from the cyst, there may be pyæmic symptoms.

To sum up: after a variable period during which there are few subjective symptoms or absolutely none, the child is noticed to be ailing, to have a swelling in the right hypochondrium, or a "big belly," and to be affected with digestive disturbances, accompanied perhaps by loss of flesh. Occasional symptoms at this stage are pain, fever, jaundice, and œdema. The liver is generally enlarged. Subsequent symptoms are produced by the pressure upon adjacent organs of the enlarging tumor, by the rupture of the tumor, or by inflammation and suppuration of the sac.

**Diagnosis.**—The diagnosis of hydatid tumor of the liver is in some respects easier in children than in adults, with the important exception that its relative rarity may lead the medical attendant to overlook the possibility of its occurrence. Diagnosis is easier in children because distended gall-bladder, phantom tumor, and aneurism, with which diseases hydatid disease of the liver in adults is liable to be confounded, are so rare in children that they may be left out of the count in diagnosis.

Hydatid tumor of the liver may be mistaken for an enlargement of the liver due to hypertrophy, to fatty and amyloid degenerations, or to malignant disease,—sarcoma or carcinoma.

When the hydatid tumor develops within the body of the liver, or behind it, in such a way that as the liver becomes steadily larger a shell of hepatic tissue is left between the cyst and the chest-wall and abdomen (as in Stromszky's case), it may be impossible to make a correct diagnosis; especially if, as in his case, puncture fails to strike fluid. But hypertrophy of the liver to such an extent as to produce serious pressure-symptoms must occur extraordinarily rarely.

In fatty liver the antecedent history is different from that obtained in hydatid disease, the constitutional symptoms are much more marked, and ordinarily the local conditions are very different. In fatty liver there is a general, uniform, smooth enlargement of the liver in a tubercular child, or in one overfed on fat-producing foods; while in hydatid tumor we have a round, smooth, painless tumor, usually unaccompanied with fever, much disturbance of the general health, or local tenderness. If in addition fluctuation of the tumor and hydatid fremitus can be detected, there would seem to be little probability of a mistake in diagnosis. Whether fluctuation and hydatid fremitus are present or not, a tumor suspected to be a hydatid cyst should be punctured. If an apparently colorless and non-albuminous fluid, containing abundance of chloride of sodium, is obtained, the probability that one has to do with a hydatid cyst is much strengthened. The diagnosis may be considered settled if hooklets are found in the fluid. In very obscure cases it would be well to examine a suspected fluid for sugar, leucin and tyrosin, crystals of cholesterin, and succinic acid.

If the patient with enlargement of the liver is pale, anæmic, sickly, and somewhat emaciated, the possibility of amyloid degeneration must be remembered. But in the latter disease both the local and the constitutional symptoms are usually very different, as there can generally be obtained a

history of syphilis or prolonged suppuration : an examination of the spleen for enlargement, and of the urine for the characteristic evidences of amyloid disease of the kidneys, will shed light upon any obscurity. Furthermore, if hydatid disease of the liver has lasted long enough to produce constitutional symptoms simulating those of amyloid disease, it will almost always be possible, by repeated attempts at puncture, to obtain hydatid fluid and thus establish the diagnosis.

With regard to malignant disease of the liver, consisting of sarcoma and carcinoma, it should be borne in mind that in countries in which hydatid disease is most likely to be found the latter will be much more common than the former. Not much difficulty is likely to be encountered in differentiating the two, however ; for in malignant disease the duration is much shorter, and it is characterized by pain, tenderness, progressive failure in nutrition, and emaciation, and by greater digestive derangements than occur in hydatid disease. Jaundice, ascites, and fever are also more common in the former than in the latter. Moreover, the enlargement of the liver is usually irregular and nodular. In very soft cancer a deceptive sense of fluctuation might lead to error, but the result of puncture with a hypodermic needle will be sufficient to prevent any mistake in diagnosis.

Abscess of the liver is distinguished from hydatid disease by the more acute character of its symptoms and by their more rapid development. While in most cases abscess is probably secondary, nevertheless the onset of the hepatitis is marked by chill, fever, pain, tenderness, and a profound disturbance of the general health. Tumor occurs in both ; but the tumor in abscess is seldom well defined, is rarely as large as a hydatid tumor, and presents physical characteristics very different from those of the typical globular, painless, fluctuating and vibrating cyst. It should not be forgotten, however, that suppuration may occur in the cyst, or in the liver surrounding it. The diagnosis may then be extremely difficult, but practically is not of great importance. In a case reported by Pontou, which has been referred to already, it will be remembered that metastatic abscesses of the liver occurred secondarily to suppuration in the cyst.

Cystic enlargements of the kidney can usually be distinguished from a hydatid cyst of the liver by their location, by the direction of their growth, and by the fact that they do not move with the liver upon deep inspiration. It may be possible, also, by careful palpation, to discover that they are unconnected with the liver, but lie along the vertebral column, from which, according to Birch-Hirschfeld, they cannot be separated. An examination of the urine may assist greatly in the diagnosis.

Effusion into the right pleural cavity presents some points of similarity with hydatid tumor of the liver. But the fluid in the former is free to move, and hence occupies a different level with the changed position of the patient. The history of the two affections is different, and so, of course, is the character of the fluid. Moreover, in the former there is no enlargement of the liver, though it may appear enlarged from the fact that it is

pressed down so as to project below the edge of the ribs. In pleural effusion there are generally cough, fever, and greater dyspnoea than is likely to exist in hydatid tumor. In estimating the probabilities it is well to bear in mind that the two affections may coexist, and that, according to Murchison, an encysted pleurisy may simulate a hydatid tumor by producing a circumscribed bulging of the lower ribs.

**Duration.**—The duration of hydatid tumor of the liver is extremely variable. It may last a few months or nine or ten years. In a single case Barrier established a duration of from fifteen to thirty years. The case mentioned by Budd, in which a woman seventy-three years old was believed to have had a hydatid tumor since her eighth year, has been referred to already. The duration in most cases is probably from two to four years. It appears to depend upon the location of the cyst, upon the vitality of the echinococcus, and upon the power of resistance of the fibrous capsule formed from its host's tissues. Where great resistance is offered to the expansion of the cyst, and where the vitality of the echinococcus is low, growth will be slower. It would appear, also, that when the vitality of the parasite has been lowered by excessive production of daughter-cysts, and especially when calcareous degeneration has affected the fibrous capsule and the animal is thus deprived of nourishment, its death may follow.

On the other hand, an accident or an injury may lead to rapid development of a cyst before apparently latent, or at least enlarging very slowly.

**Prognosis.**—Judging by the statistics at hand, hydatid disease of the liver is more fatal in children than in adults. The cases tabulated by Thomas, and already mentioned, were all obtained from mortuary records, so that only a very general inference can be drawn from their number. In the thirty-three cases collected by the writer, there were twenty-two recoveries and nine deaths; in two cases the result was not stated. It will be readily understood that a hydatid cyst so situated as to press upon the vessels of the liver will be a source of greater danger than one which is free to grow into the abdominal cavity. In the latter situation, also, the prognosis would be more favorable, because the cyst could be recognized and aspirated more readily. While in some instances the parasite dies, the contents of the cyst become transformed into a putty-like or plaster-like mass, and its walls undergo calcareous degeneration, this spontaneous cure is the exception, and there is no known way of producing it artificially. If the parasite continues to live and the cyst to grow, the result will be the death of its host, unless the contents of the cyst are evacuated, either spontaneously or artificially. The prognosis is, therefore, more favorable when the disease is recognized early and admits of operative treatment.

The gravity of the prognosis is greater when there are a number of cysts than when there is only one, and when secondary tumors form, and is gravest in the multilocular variety. In the latter death almost always

results. It is a curious fact that most of the cases hitherto reported (nineteen out of thirty-five, according to Neisser<sup>1</sup>) have occurred in Switzerland, and in Germany it is found almost exclusively in the south.

Rupture externally, into the intestine, and into the bronchi, is, in general, a favorable issue; but when rupture takes place into the peritoneal or the pleural cavity, or into the veins, death is the usual result. It is probable, however, that the increased success which surgeons have achieved in dealing with affections of the abdominal and pleural cavities will in future lessen the mortality from rupture of hydatid cysts into these cavities. Rupture into the bile-ducts is an unfavorable issue.

Other complications, such as suppuration of the sac, with or without subsequent rupture, pleurisy, pneumonia, peritonitis, and the development of severe pressure-symptoms, all add in varying degrees to the gravity of the prognosis.

In the average case, when there is but one cyst, and that is susceptible of operative treatment, the prognosis is good.

**Treatment.**—Hydatid disease is pre-eminently a preventable disease. So far as man is concerned, it may be stated as an axiom that where there are no dogs there will be no infection with the echinococcus. The custom of having a dog as a household pet, which is allowed to lick the hands and faces of the children, is not free from danger in any country, but it is highly objectionable in those countries in which hydatid disease is prevalent, and is especially so with dogs engaged about sheep, hogs, and cattle. Dogs should be prevented from feeding upon the offal of the animals just named, and the water-supply for drinking purposes should be guarded against contamination. One of the best safeguards against infection is undoubtedly an intelligent appreciation of the danger to be incurred. This of itself will lead to greater cleanliness in habits of living, to a wholesome nicety in the choice of food, and to its proper purification and cooking. The food of the dogs should also be cooked.

Internal remedies, to destroy the parasite or to modify its course, are useless. Iodide of potassium and common salt were thought at one time to have this power; but how little can be expected from any medicine will be best illustrated by recounting the experience of Dr. Leidy. He says that he once received for dissection the body of an English sailor which had been injected with zinc chloride for preservation. In the abdominal wall in the right iliac region there was a hydatid tumor the size of a fist. On examination of the tumor it was found full of daughter-cysts, and these contained living scolices, though the man had been dead several days and the tissues were bleached by the zinc solution.

It will be evident from what has been said under prognosis that effective treatment is surgical. In many cases aspiration is all that is necessary. In others incision appears to be required.

---

<sup>1</sup> Quoted by Leuckart.

*Bibliography.*—Birch-Hirschfeld, *loc. cit.*; Hensch, E., Beiträge zur Kind., 1861, p. 128; Stromszky, A., Jahrb. für Kind., 1881, xvii. 294; Pontou, Thèse, Paris, 1867; Lehret, Comptes-Rendus de la Soc. de Biol., 1849, 68; Thieberge, G., Bull. de la Soc. Anat., 1882, lvii. 109; Küster, E., Deutsche Med. Woch., 1880, p. 7; Petel, L'Union Méd., 3e S., 1878, xxvi. 102; Bourdel, Paul, Bull. de la Soc. Anat., 1884, lix. 320; Murchison, Clinical Lectures on Diseases of the Liver, p. 7; Leidy, Joseph, article on "Intestinal Worms," in Pepper's System of Medicine, ii. 943; Fagge, Hilton, Practice of Medicine, ii. 328; Thompson, H., Trans. Path. Soc. Lond., ix. 294; Lafforgue, Jour. de Méd. et de Chir. prat.; Leared, Trans. Path. Soc. Lond., xiv. 176; Edge, London Lancet, 1881, ii. 747; Verco, Australian Medical Gazette, 1886-87, vi. 191; Mackenzie, Stephen, Medical Examiner, London, 1878, iii. 331.

#### TUMORS OF THE LIVER.

Under the above general term all forms of tumors of the liver will be included. The writer has been able to collect nineteen cases of primary malignant disease of the liver, divided as follows: adenoma, two cases; lymphadenoma, two cases; carcinoma, ten cases; sarcoma, five cases.

The clinical account in these pages will be based on an analysis of the cases above noted. In addition some tumors of the liver have been reported which were not malignant in character, but which were no doubt the primary cause of death. They are rare, and will be found in the abstracts of cases which the writer has added to this section. (Cases XIX., XX., and XXI.)

Of these, the case of Luschka presented some features of interest. At the birth of the child, which was premature, the abdomen and veins were enlarged and the skin was pale yellow. Twelve days after birth, hemorrhages from the cord, the stomach, and the bowels took place, with œdema of the lower limbs. Four weeks after birth the child died. At the autopsy a round fleshy tumor was found which had its origin in a hemorrhage into the parenchyma of the liver. Except the enlarged veins and prominent abdomen, the symptoms were like those of malignant jaundice. The case of Hueter presented symptoms which, in the occurrence of pain, enlargement of the abdomen, and presence of a tumor, resembled those of malignant disease of the liver. It was considered to be malignant disease of the kidney associated with ascites. An operation determined the presence of an enormous cyst of the liver which filled the entire abdomen, and in the sac of which a firm mass of clots or necrotic tissue was found which had been detected on palpation and mistaken for tumor of the kidney. The patient recovered.

In addition to the tumors the origin of which is primarily in the liver, secondary tumors are found which cause the same symptoms and are the cause of similar enlargement of that organ. In cancer of various organs of the body the liver is secondarily involved. The primary seat of the growth is often very obscure, and hence practically the liver-affected alone is held to be the process in progress. In other words, the symptoms of the secondary disease in the liver are frequently the symptoms of the disease, and the case is considered one of hepatic disease. It may be taken



for granted, therefore, that the symptoms of secondary cancer of the liver are the same as those of the primary form. It will not be referred to again.

We likewise find tumors of the liver associated with or part of a similar process in other organs or structures of the body. Thus, lymphoma, lymphadenoma, or lympho-sarcoma of the liver (Case XXII.) does not usually exist alone, but in conjunction with the same disease in other organs. The cystogenic tumor which Wagner describes and which Birch-Hirschfeld includes in his article on malignant tumors of the liver belongs to the same class. In this case similar growths were found in the small intestine, the peritoneum, and the kidney, but the enlarged liver was in the foreground, and hence the distinguished author quoted thinks it should be treated of as a case of tumor of the liver. So with the other varieties: the hepatic symptoms are the most prominent, and hence the cases are classified under liver-disease. Cases of this class are not included in the following discussion, and are simply alluded to in this instance as examples of enlargement of the liver. An abstract of a case is also appended to illustrate enlargement of the liver from tuberculosis of that organ.

**CARCINOMA AND SARCOMA OF THE LIVER.**—Cancer of the liver is rare. Birch-Hirschfeld has noted twice in four hundred sections of newborn children general diffused cancer in the form of roundish nodes whose circumference for the most part did not surpass the size of a pea, which presented no symptoms during life. The rarity of cancer of the liver simply corresponds to the rarity of carcinoma in general in early life. In 1851 Lebert cited fifteen instances of cancer in early life, and in 1867 Duzan mentioned nearly two hundred. This includes cancer of all the organs and tissues. The latter author affirms that cancer in children is almost always encephaloid. Wilkinson and Rokitansky have noted the existence of scirrhus in very young subjects. Deseroizilles, from whom the above is drawn, states that cancer occurs exceptionally in the liver, and quotes Charon and Ledegank and also Germain-Sée in support of the statement. He refers to a case which Bouchut met with, and quotes the case of Lewis, of which we give an abstract. Of Bouchut's case we could not find a record.

Of the seventeen cases collected by the writer, six were sarcoma, ten were carcinoma, and one was adenoma of the liver. They are studied together in the following *résumé*.

**Etiology.**—No cases are included over fifteen years of age. The youngest case was three weeks old; it was a diffused sarcoma. Under one year six cases, or one-third of the entire number, are reported; in the second and the third year, two cases each; in the twelfth year, three cases; and one each at the age of nine, eleven, thirteen, and fourteen years. The sex was not always given. Of the eleven cases in which the sex was recorded, five were females and six were males. In the larger number of cases there was no hereditary history of disease, and in three instances only was there mention of an injury which might have been referred to as the cause of malignant disease.

**Symptoms.**—The symptoms developed rapidly, and the disease ran a rapid course. Pain in the region of the liver was first complained of usually, without other symptoms. General enlargement of the abdomen was soon observed, and the veins in the abdominal walls were seen to be prominent. With this the liver was found to be enlarged, its surface and edges irregular, and while under observation it grew rapidly and was the seat of pain; or a defined tumor connected with the liver was detected. Gastro-intestinal symptoms accompanied the local symptoms, and emaciation, progressive in character, with increased prostration, soon took place. Fever was observed in a few cases. Jaundice was very rare, and enlargement of the spleen and ascites were notably absent. Enlargement of the veins is more peculiar to children than to adults, in this affection.

In two of the cases no clinical history was detailed. The following account of the symptoms, their character and frequency, is taken, therefore, from an analysis of the fifteen cases in which they were given.

1. *Pain* in the hepatic region was complained of six times, and in the region of the stomach once. In one instance it was seated in the right hypochondrium and extended to the left shoulder. It usually occurred in the beginning of the disease, but in one of the six cases the pain did not occur until the last week of the patient's illness. Tenderness without pain was noted in one instance. In some cases the pain was due to the growth itself, but in most of them to the complication of localized peritonitis.

2. *Enlargement of the Abdomen.*—Enlargement of the abdomen without cause was spoken of particularly in three instances. It is, however, a common attendant of hepatic carcinoma. In one it was said to be firm and livid, in another its surface was said to be irregular, and in the third its character was not described.

3. *Enlargement of the Veins.*—Enlargement of the veins of the abdomen was noted in six cases.

4. *Tumor*, described either as one mass or as a number of projections over the surface of the liver, was found in eight cases. Thus, in one it was said to extend from the sixth rib to the iliac fossa and from the vertebra to the linea alba on the right side. Over its surface elevations, soft in character, the size of a child's fist, were seen and felt. In another it was said that the tumor extended from the chest to the pelvis and that it was firm and immovable. In a third dulness extended from the xiphoid to the hypogastrium and in the lumbar and iliac regions, on account of a smooth resisting mass which filled up the entire abdominal cavity except a small space in the hypogastric region. Practically, the above-described tumors were really due to enlargement of the liver, not independent of or adjacent to it, and hence were not tumors of that organ. They should be studied in connection with the subsequent remarks on enlargement of the liver. Specifically, a tumor was described in the following localities: first, in the epigastrium, to the right of the median line, between the umbilicus and the base of the chest; second, at the umbilicus, like a fluctuating prominence; third, at

first at the last ribs on the right side, before death in the right hypochondrium and epigastrium as an elastic fluctuating mass. In another case the tumor was the size of a hen's egg and was seated in the epigastrium. In the case of West the position of the tumor was not defined. The tumor was the seat of pain twice, and was painless in three instances. The skin of the surface of the tumor was red in one case in which there was fluctuation. While hard and firm in a few instances, it is important to note that it was elastic and fluctuating in three cases. This fluctuation was so marked as to lead to the diagnosis of hydatid cyst or abscess.

The large size and rapid growth and the softening and fluctuation appear to characterize the malignant tumors of the liver in childhood.

5. *Enlargement of the Liver.*—This in five cases was positively said to exist during life, and in five other instances it, presumably, was determined before death, for in each a tumor of the abdomen was described which the autopsy showed to be due to carcinoma of the liver. (See above, under Tumor.) The enlargement was very great, and much greater in proportion to similar diseases of the liver in adults. Thus, in one instance the liver was found by percussion and palpation to extend from the third rib to four inches below the margin of the ribs, or from the chest to the pelvis, and in another to fill the entire abdominal cavity except a small space in the hypogastric region. The surface of the liver was usually irregular, and the elevations or prominences over it have been defined as soft, or elastic and fluctuating, or as bossy swellings which were umbilicated. The fluctuating projections in several instances yielded, on palpation, signs similar to those yielded by a cyst, and were punctured with a view of securing cystic fluid. In all the instances in which aspiration was performed nothing but blood was withdrawn. In one case the liver, it is said, extended from the clavicle to the pelvis.

The same remark as to the size, growth, and character of the tumor of malignant hepatic disease in childhood applies to the organ itself.

6. *Ascites and Œdema.*—This was usually absent. In two cases its presence was determined before death. Œdema of the legs occurred, no doubt from pressure, in three instances.

7. The *spleen* was not enlarged.

8. *Jaundice* was observed in three cases. In one only was the jaundice very deep. No special secondary symptoms were caused by it, and the course of the disease was not influenced by its presence.

9. *Gastro-Intestinal Symptoms.*—Nausea and vomiting occurred in four cases. Diarrhœa was found in three cases, and constipation was noted in one. A striking fact is the great frequency of cases in which the gastro-intestinal were the first symptoms. The illness was ushered in with vomiting and diarrhœa.

10. *Fever* was most marked in one case (Pye-Smith), but was noted also in three other cases. It was associated with a tumor which was soft and fluctuating and which gave rise to the belief that abscess of the liver was

present. The rapidly-growing cancer often causes so-called hepatic fever. It is rather remarkable that this symptom was not more common. It may not have been looked for.

Finally, the character, mode of onset, and progress of the symptoms did not indicate the form of malignant disease present.

*Duration.*—Usually the cases were of short duration; the longest was under observation seventeen months. The shortest appeared to be a growth of ten days only (Pepper). The sarcomas grew more rapidly and caused death sooner, on the whole, than the carcinomas,—one month, ten weeks, and three, four, and five months, respectively, being the duration in five cases.

No relation between the size of the growth and the duration of the disease could be made out that was of any importance. It may be said, however, that the larger new growths were produced more rapidly. One of the largest of the encephaloid carcinomas was of forty-five days' duration only.

The duration of the ailment had no influence on the character of the carcinoma, if we accept the data of these cases. The example of scirrhus occurred in a child nine months old. This is not contrary to the rule generally regarding the duration of various malignant growths.

Practically, it may be possible to say that if the new formation in the liver grows rapidly it may be a sarcoma.

*Diagnosis.*—The diagnosis in individual cases was not difficult: indeed, it appears easier to distinguish carcinoma in children than in adults.

Hydatid disease and abscess of the liver were discussed by several of the authorities quoted in the appendix, in connection with their particular cases. The results of aspiration usually led them to exclude these affections. One can appreciate difficulties, however, in a case where, from carcinoma, hepatic symptoms—pain, enlargement of the liver, a tumor, and slight fever—arise after direct trauma. The suffering does not seem to be so great, however, as in abscess, the fever is not so high, and the sweats are not so marked. The liver is generally larger in cancer, and can be percussed and palpated with less suffering. The abdominal veins are more likely to be enlarged. Emaciation characterizes both, but in carcinoma is coupled with cachexia and is very marked. A full discussion of the distinctions will be found in the article on abscess of the liver. Hydatid disease is painless, almost symptomless, and chronic. The tumor is larger and has characteristics described in that section.

We have purposely omitted a description of the anatomical characters of tumors of the liver. In the appended abstracts of cases will be found good individual descriptions. Moreover, they do not differ much from the same structural changes in adults, the characters of which one can readily learn in the vast number of text-books on pathology. That the malignant growths of childhood are more diffuse and more luxuriant than those of adult life, is well known.

Concerning the prognosis and treatment nothing need be added.

*Bibliography.*—Pye-Smith, H., *Trans. Path. Soc. Lond.*, xxxi. 125; Farre, quoted by Frerichs, *Diseases of the Liver*, iii. 55; Tooth, H. H., *Trans. Path. Soc. Lond.*, xxxvi. 236; Gee, S. J., *St. Barthol. Hosp. Rep.*, 1871, vii. 143; Parker, R. W., *London Lancet*, 1880, i. 768; Pepper, William, *Trans. Path. Soc. Phila.*, 1874, iv. 97; Lewis, C. J., *Chicago Med. Jour. and Exam.*, xxxiv. 323; Meisenbach, *Weekly Med. Rev.*, 1884, ix. 433; Gross, S. W., *N. Am. Med.-Chir. Rev.*, 1857, i. 414; Henschen, *Jahresbericht (Virchow and Hirsch)*, 1887, Bd. ii.; Kottmann, A., *Corr.-Blatt für Schw. Aerzte*, 1872, 469; Deschamps, E., *La France Médicale*, 1885, i. 809-813; Ashby and Wright, *Diseases of Children*, London, 1889, p. 145; Birch-Hirschfeld, *Gerhardt's Handbuch*, Bd. iv. Abth. ii., 665-836; Ollivier, *La Clinique des Hôpitaux des Enfants*, etc., 1841, 399; Savard, *Bull. de la Soc. Anat.*, 1880, lv. 291; Luschka, *Virchow's Archiv*, 1858, xv. 168-171; *Archiv für Kind.*, 1886, vii. 138; Hueter, C. F. C., *Inaug. Diss.*, Göttingen, 1887; Descroizilles, *op. cit.*; and the works of West, Henoch, Ashby and Wright, and Baginsky, on Diseases of Children.

#### ABSTRACTS OF CASES OF CANCER AND OTHER TUMORS OF THE LIVER.

*Case I., Encephaloid Cancer.*—Girl thirteen months old. For some time she complained of continual suffering. When first seen, in April, 1834, a painless tumor in the liver-region, at the level of the last ribs on the right side, of considerable volume, was found. The skin was stretched over it and brilliant as in phlegmonous erysipelas, but presented only slight redness and no pain on pressure. Appetite good; no fever; no general trouble. After three months the tumor occupied the right hypochondrium and epigastrium; it was painless, elastic, fluctuating to the touch; no bosses. Some fever; emaciation. Death occurred September 19, prior to which fever was for some time very pronounced. At the autopsy an oblong tumor twice as large as the child's head was found. Encephaloid cancer. The child had a fall a short time before. (Ollivier.)

*Case II., Cancer.*—Female aged nine. Was ill about a year, suffering pain in the region of the stomach towards the last. There was vomiting the latter half of the year, with symptoms of marasmus and general anasarca; no jaundice, no albuminuria. Post-mortem: poorly-developed child, very thin; general œdema; primary cancer of liver. (Kottmann.)

*Case III., Cancer.*—Girl aged fourteen. On December 18, 1881, she was attacked with pleurisy of the right side. The liver was somewhat enlarged. By February, 1882, the pleurisy was cured; two months afterwards the girl became cachectic, with fever. There was marked enlargement of the liver, in which were spots of fluctuation. Puncture evacuated a bloody fluid containing a few lymphoid cells, fibrin threads, and fatty degenerated angular (liver) cells. At the autopsy a widely diffused telangeiectatic cystic cancer of the liver and thrombosis of the inferior vena cava were found. (Henschen.)

*Case IV., Encephaloid Cancer.*—Boy eleven years old, admitted February 24, 1881. He had enjoyed good health prior to February 12, when he felt pain in upper part of abdomen, especially in hypochondrium, radiating into the back of the left shoulder, with irregular exacerbations; slow digestion, flatulence, and constipation. No injury in hepatic region. For four or five days nose bled seven or eight times a day. When he entered the hospital, he was very thin, cheeks a little colored, eyes brilliant, conjunctiva slightly icteric. Responds clearly to questions put to him, and seems intelligent. He lost much flesh within fifteen days. Skin warm; pulse a little more frequent than normal, 100. Respirations 34. No appetite; no vomiting; no constipation. Abdomen much swollen, noticed by mother five or six days before admission to hospital, and at that time said to have been very hard. Subcutaneous abdominal veins dilated. In the epigastrium below xiphoid, abdominal wall elevated by a tumor extending into right and left hypochondrium and much more prominent at epigastrium and a little to the right of median line between umbilicus and the base of the chest. It seems convex. Distance from xiphoid to umbilicus fourteen centimetres, from left anterior iliac spine twenty-three and from right twenty-one centimetres; circumference of the body at the umbilicus sixty-six centimetres. Palpation meets with resistance at the most prominent part between this point and the costal border, then a small and separate tumor is felt of the size of a little walnut. Liver increased in volume considerably, and its border

felt distinctly two or three finger-breadths above umbilicus; no hydatid vibration. February 26, profuse epistaxis. On puncture about fifty grammes of a red liquid withdrawn, only pure blood. March 1, more acute abdominal pain and local peritonitis; pain increased in severity to the 4th. March 6, small hard nipple-shaped tumors felt above four or five finger-breadths above pubis, not movable. They seem to be adherent to the liver, and also constitute the border of it. March 12, liver increasing in volume, pain more and more acute. Epistaxis more and more frequent. Temperature remains about 38° C., but pulse is between 120 and 130, and respirations are 35 to 40 per minute. Cachectic and thin. No vomiting; tendency to constipation. Urine remains scanty; the greatest quantity of urea in twenty-four hours is three and a half grammes. Usually it varied between one and a half and two grammes, and often fell as low as twelve decigrammes. Peritoneal friction disappeared little by little, and abdomen increased in volume. Ascites appeared and became considerable in the last days of the disease. Some signs of bronchitis and a little congestion in the base of the lung were demonstrated. Pain very acute during whole duration of disease. Patient died exhausted March 29. Duration of disease forty-five days.

*Autopsy.*—Liver very large, extending four or five finger-breadths beyond pubis; large cancerous tumor occupies greater part of right lobe, the edge of which with its bosses had during life been felt above the pubis. Cancer, encephaloid, primary. Liver weighs three kilogrammes and two hundred and seventy grammes. (Deschamps.)

*Case V., Cancer.*—Female three years old; no clinical history. Left lobe of liver transformed into a large tumor-mass, extending to upper surface of the right lobe. Surface of the left lobe lumpy; tumor in most places soft. (Wolff, from Birch-Hirschfeld.)

*Case VI., Cancer.*—Boy of twelve; history unsatisfactory. Tumor situated in right lobe of liver; corresponded with the nodular form of adenoma of the liver, and in some places there is already pronounced change into carcinoma. (Birch-Hirschfeld.)

*Case VII., Sarcoma.*—Girl twelve years old, sick for four months with pain in liver-region. For one month swelling of abdomen and thoracic region from the right collar-bone to the navel, and at last place a fluctuating prominence. Hydatid diagnosed. On puncture, evacuated bloody serum. Four weeks later death, prior to which pronounced cachexia and œdema of limbs. On section, tumor right lobe of liver occupying whole place on the right side from clavicle to pelvis. Medullary spongy sarcoma. (Roberts, *Lancet*, 1867, i. 3, quoted by Birch-Hirschfeld.)

*Case VIII., Sarcoma.*—Child aged two and a half years. Presented for treatment in February, 1878. Healthy until Christmas, 1877, when the abdomen became enlarged. The liver was found to be much enlarged. Rapid increase during the next few weeks. Flat, soft, almost fluctuating projections can be distinctly felt upon the liver. Dilatation of veins of abdomen and lower part of thorax, increased emaciation, slight jaundice. Death March 23.

*Autopsy.*—Liver enlarged threefold, yellow. Contains at the periphery and internally numerous yellowish-white, soft tumors from the size of a hazel-nut to that of a walnut. Gall-bladder dilated; cystic duct compressed by a tumor. All other abdominal organs normal. Other viscera not examined. Medullary sarcoma. (Hench.)

*Case IX., Sarcoma.*—Male aged eight months was taken sick with diarrhœa, lost appetite, and became emaciated. When nine months old a solid tumor was noted by mother in abdomen. Profuse diarrhœa continued and child rapidly emaciated. Disease lasted four months. In first six weeks of life the circumference of the abdomen increased from twenty-one to twenty-five inches, while the tumor, with uneven surface, was best felt on the left side. At autopsy left lobe of liver healthy and enlarged; right lobe pressed under ribs, and in it a medullary sarcoma. Separate nodes found in right lung. Other organs healthy. (West.)

*Case X., Adenoma.*—Boy aged twelve years. "Nothing in history to throw light on case." No evidence of congenital syphilis. Boy stated that three months before admission he fell on his side, after which he noticed a swelling, which sometimes gave him pain.

*Symptoms.*—General health and general condition good. Occasionally pain over liver and some sickness of stomach. No ascites. He gradually became thinner, and two weeks

before death became deeply jaundiced and some œdema arose. Temperature 102°-104° F.; pulse 144; respiration 42. Duration about seventeen months.

*Physical Signs.*—Liver extended three or four inches below ribs; firm, smooth, and elastic; on puncture, a little blood was drawn, but no pus; no signs of echinococcus. After puncture the swelling decreased and health remained good for several months; then liver gradually increased in size. Superficial veins enlarged. No enlargement of lymphatics. No evidence of organic disease in other organs.

*Autopsy.*—Extreme jaundice; œdema of legs and scrotum. Abdomen contained some fluid; no peritonitis. Liver enlarged two hundred ounces. Right lobe much enlarged and filled with circumscribed yellow masses, some microscopic, some the size of an orange; nodes on surface. Portal trunk and common bile-duct completely blocked. No parent growth appeared; all appeared coeval. No primary growth in pancreas, duodenum, or bile-duets; no lymph-glands in fissure of liver or elsewhere enlarged. Spleen enlarged. Other organs normal. Tumor was epithelial in structure. Lungs normal, except in right base, where there was a nodule like a shrunken infarct; this was made up of microscopic malignant nodules, each of which consisted of a fibrous sheath enclosing epithelial cells like those in the liver. The author believes the tumor to be a malignant adenoma. (P. H. Pye-Smith.)

*Case XI.*—Carcinoma in an infant four months old. Healthy up to a month previous. Parents healthy. Child became fretful, developed diarrhœa, and lost flesh.

*Physical Examination.*—A swelling in epigastrium the size of a hen's egg. Tumor firm, tender, increasing in size. Belly distended; superficial veins enlarged. Duration one month.

*Autopsy.*—Liver occupied whole of abdominal cavity above umbilicus. Very little fluid in peritoneal sac. Mesenteric glands not enlarged, and all other viscera normal. Liver weighed forty and one-half ounces; glands in hilum not involved. Both lobes studded with tough, whitish foreign growths. Microscopic examination revealed connective tissue enclosing numerous round cells. (S. J. Gee.)

*Case XII.*—Diffuse sarcoma in liver of an infant three weeks old. No evidence or history of syphilis in parent. Child was found to have a very large liver, almost filling abdomen; surface of abdomen irregular. Veins distinct. Slight œdema of legs and belly-wall. No ascites. Very little intestinal resonance. Child died when three weeks old.

Autopsy confined to abdomen. Liver weighed thirty-three ounces; dark plum-color, quickly changing to red on exposure. Gall-bladder rudimentary. On section, growths from the size of a millet-seed to that of a walnut were found. Similar growths were found between spleen and left kidney, but not involving either. Other organs healthy. Spleen not enlarged.

Treatment had been mercurial inunctions, which produced no effect.

(Dr. Pye-Smith thought it diffuse intestinal hepatitis; others thought it syphilis.) (R. W. Parker.)

*Case XIII.*—Cancer of liver in a child eight weeks old. Parents healthy, father forty, mother thirty-six; two healthy children, fourth child an epileptic. Patient well at birth, and health good up to ten days before death, when enlargement of abdomen was noted. This was firm and hard; no sense of fluctuation. Enlargement rapidly increased; veins prominent; no jaundice, no emaciation, no cachexia. Only marked symptom was pain, which caused child to cry out, and which seemed to be increased when child was laid on left side. Urine normal. Stools natural, though green at first.

*Autopsy.*—No peritonitis. About eight ounces of clot and fluid blood in abdominal cavity. One clot over large mass springing from liver at a point of rupture. Other organs healthy. Liver weighed eleven ounces three hundred and seven grains; measured six inches transverse diameter. No inflammation of capsule, which was smooth. Organ yellow in color. Gall-bladder healthy and passage free. Left lobe was seat of a large round growth which occupied its entire extent. Tissues and mass dark, in places almost black. Committee reports cancer. (Pepper.)

*Case XIV.*—Encephaloid cancer in a boy aged thirteen years, born in Sweden. No history of cancer in family. Four months previous was kicked on right side below ribs, which caused him to remain in house one month. About two weeks after injury he was

seized with vomiting and diarrhoea, which continued throughout. Four months after injury abdomen began to swell. He had measles one year previous, from which he made good recovery.

*Symptoms.*—Tongue red at tip and edges, brown fur in centre. Eight or ten stools daily, sometimes dark, sometimes light. Temperature normal; pulse 105, small. Rapid loss of flesh and strength, and during last weeks intense pain. Duration about five months.

*Physical Examination.*—On face, arms, and chest, fine papular eruption, copper-colored and with scaly desquamation. Tumor occupying and filling abdomen, extending into chest and down to pelvis; firm, immovable, not tender, thought to be syphilitic.

*Autopsy.*—All organs normal except liver. Liver nodulated and doughy to feel. Attached to anterior surface was a large yellowish-white granular mass filling nearly the entire abdomen. Weight six pounds ten ounces (avoirdupois). On section, liver looked like fresh suet. Under microscope an endless variety of cells of all sizes and shapes, together with fatty granules and degenerated hepatic tissue. It was pronounced encephaloid cancer. (J. Lewis.)

*Case XI.*—Myxo-sarcoma in infant four months old. Mother aged between thirty-five and forty, average health; father died of phthisis. Nothing unusual at birth. Some weeks after birth noticed a swelling in abdomen, and navel protruded, teat-like. No history of specific disease.

*Symptoms.*—Restlessness, short cough, vomited milk; nursed pretty well, but did not thrive. Lost flesh and strength. Temperature normal. Lungs normal.

*Physical Examination.*—Abdomen excessively and symmetrically enlarged. Veins prominent. Percussion-dulness extending from xiphoid cartilage to hypogastric region and laterally and posteriorly into lumbar and iliac regions. On palpation, firm, smooth, resisting mass filling entire abdominal cavity, with exception of small space in hypogastric region, where on deep pressure margin could be felt.

*Treatment.*—Iodide of potassium and calomel to child, under which treatment liver-tumor seemed to diminish slightly in size. Duration about nine or ten weeks.

*Autopsy.*—Small quantity of fluid in abdomen. Liver filled abdominal cavity; smooth and symmetrical; color mottled, like red Castile soap. Spleen and kidney normal, but mottled. Other organs normal, except lungs, which presented caseous deposit, no amyloid change. Microscope showed it to be myxo-sarcoma. (Meisenbach.)

*Case XII.*—Scirrhus in a colored boy aged three months. Three weeks before, he had suffered from vomiting, cough, and dyspepsia. Abdomen swollen. Appetite unimpaired.

*Autopsy.*—Peritoneum contained a small quantity of fluid. Some evidence of recent inflammation of lesser omentum; mesenteric glands somewhat enlarged. With exception of liver, all organs normal. Liver of natural size, firm, and of good color. On anterior mass of left lobe were three scirrhus masses projecting from surface, which looked like fibro-cartilage. Six other patches were found, varying in size from that of shot to that of a three-cent piece. On under surface there was a conical mass the size of a walnut. Anterior border of right lobe involved to some extent. Microscope showed remarkably distinct scirrhus structure. (S. W. Gross.)

*Case XVII.*—Adenoma of the liver in a female infant twenty months old,<sup>1</sup> who is said to have suffered for three months with loss of appetite and much swelling of the belly, and since that time to have markedly emaciated.

*State on Admission.*—Height normal; emaciated; skin pale yellow, relaxed; tongue dry, somewhat coated. Belly much swollen. Right side completely filled with a tumor extending in the mammary line from the sixth rib to the iliac fossa, and in the transverse direction at the level of the navel from the vertebrae to the linea alba. This tumor presents on palpation several elevations from the size of a nut to that of a child's fist, projecting from the level of the liver, which feel soft against the very resisting liver. Palpation of the tumor causes no pain. Circumference of the belly fifty-one centimetres, the skin being traversed by large veins. Percussion-note in the whole extent of the tumor empty. Inguinal glands moderately swollen. In the lungs, except moderately large and

<sup>1</sup> Jahresber. des St. Joseph Kinderhospitals für 1883, i. 42.



fine blowing râles, there are no essential changes. Splenic dulness is increased. Stools dark yellow, mushy. Traces of albumen in the urine. Skin-temperature 99.1° F.; pulse 88. Increasing weakness; complete exhaustion; death on the thirteenth day after admission.

*Autopsy.*—Apart from pleuro-pneumonia of the right middle lobe of the lung and from certain unessential changes in the other organs, the liver was found enlarged, weighing sixteen hundred grains. Its surface seemed very knob-like, from the projection of the numerous variously-sized tumors. On cutting into the liver it was discovered that, with the exception of the peripheral parts, it was completely substituted by a very soft yellow tumor mass, sprinkled with red as the result of numerous hemorrhages, this mass being separated from the still resisting liver-tissue by a thin capsule. It was divided again by numerous connective-tissue septa into segments of different sizes, showing that it arose from the confluence of numerous individual tumors. In addition, in the peripheral parts of the organ were numerous pea-sized to more than walnut-sized tumors, which were likewise sharply separated from the liver-substance, and exhibited the same properties as the large tumor. Some of them were so soft that they almost fluctuated. The swollen tumors seemed simple, the larger already traversed by fibrous septa. The scanty remainder of the liver-tissue was very soft, and spotted pale brown and yellow.

Careful microscopic examination of the tumors, conducted by Dr. Weichselbaum, revealed the fact that the new formation described is to be regarded as an atypical liver-cell adenoma, a very rare occurrence, especially in so young a child.

*Case XVIII.*—Lymphadenoma of liver in a boy of fourteen, who for a month before coming under notice suffered with pain in right hypochondrium and wasting. He noticed a swelling in same region about two weeks before admission. When first admitted he was pale and sallow, but not jaundiced. The liver was enlarged, edge reaching nearly to the umbilicus; there was a large bossy swelling situated between the right costal arch and the umbilicus. The superficial abdominal veins were enlarged and tortuous. By aspiration blood was withdrawn. Wasting; hectic; temperature 98°-102° F. Peritoneum and pleura distended with fluid. Death seven weeks after admission, symptoms having existed for three months.

*Autopsy.*—Abdominal cavity contained much fluid. Right lobe of liver was much enlarged and contained a hemispherical mass which on section had the appearance and consistence of brain-tissue; some hemorrhage into its substance, and fibrous bands passed through it. It was surrounded by a broad zone of compressed liver-tissue; mass of enlarged glands at fissure. Right pleura full of fluid. On microscopical examination of new growth it was found to resemble structure of lymph-glands. Reporter thinks it started in lymph-glands of fissure and grew into and compressed the liver-tissue. (Ashby and Wright.)

*Case XIX.*, *Immense Connective-Tissue Tumor of Liver.*—Boy, born prematurely by a few weeks, weighing six pounds nine ounces, and came into the world with a strikingly pale yellow skin and with a swollen belly through which subcutaneous veins showed. Twelve days after birth, when the remains of the umbilical cord had fallen off, some bleeding occurred from the umbilical vein, and subsequently the bleeding recurred repeatedly. The stools during the entire duration of the child's life were blackish brown. In addition there was frequent vomiting of a dark, partly fluid, partly coagulated blood. Edema of the scrotum, of the penis, and of the lower limbs occurred constantly in a pronounced degree.

*Autopsy.*—Four weeks after birth. Liver dirty greenish yellow, surprisingly large. Immediately behind the transverse fissure of the liver, corresponding with the Spigelian lobe, was a round fleshy tumor, two and three-sixteenths inches long, one and twelve-sixteenths inches broad, which in part sank into the depths of the parenchyma, and in part projected free of it.

After a full description of the naked-eye and microscopic appearances of the tumor, the author remarks, regarding the origin of it, that most probably it arose from a hemorrhage into the parenchyma of the liver, which occurred without doubt during fetal life. Careful questioning could not obtain the least foundation for the opinion that it was due to congenital syphilis. (Luschka.)

*Case XX.*, *Cyst of the Liver.*—Girl eleven years old, admitted May 28, 1886. Well until previous Christmas; then passed ten thread-worms, and belly was noted as large. For three weeks has complained of pain. Tumor increased. Stools always thin and white.

Appetite diminished. Belly much swollen, fluctuating, dull, decided undulation. Palpation shows on left side a firm tumor, which may belong to kidney or to spleen. Liver-dulness over fourth rib; mammary line, therefore, pressed up. Urine normal.

*Diagnosis.*—Ascites, and probably malignant tumor of kidney.

*Operation.*—Enormous cyst extending from under surface of liver and filling entire abdomen. No ascites. Cyst removed. In large sac a firm mass of clots or necrotic tissue, which was detected on palpation on left side and mistaken for tumor of kidney or spleen. Patient recovered. There were several small flat cysts in neighboring parts of liver, with milky contents.

The cyst was regarded as a new formation. (C. F. C. Hueter.)

*Case XXI., Lymphadenoma.*—Female aged five. New formation of cystogenic tissue. Was not limited to the liver, but affected the small intestines, peritoneum, and the kidney, so that it is doubtful where it was primary, but clinically the liver-tumor was always in the foreground and it was anatomically the most developed. (Wagner.)

*Case XXII., Diffused Lympho-Sarcoma of Liver.*—Child five years old. Family history good, no hereditary taint. Child's health always good until present illness.

*Symptoms.*—For six months previous to examination child suffered with anæmia and enlargement of glands in neck. No mention of jaundice or ascites. Lost flesh. From time to time had attacks of diarrhœa and slight hemorrhage from bowels, and just before death repeated epistaxis.

*Physical Examination.*—Liver extending within one inch of pubis (character of enlargement not noted). She died extremely emaciated. Urine normal.

*Autopsy.*—Glands of neck and axillæ enlarged. Caseous tubercular masses in both lungs. Spleen and kidneys normal. Abdominal lymphatics slightly enlarged. Liver uniformly enlarged, weight forty-eight ounces; pale and firm; showed no isolated growths; surface smooth, edge not everted. Microscopical examination showed infiltration with small round cells resembling leucocytes and some increase of connective tissue.

Tooth does not think it leukæmia, because the liver was within an inch of pubis two months after anæmia first appeared, and because spleen was not involved. (H. H. Tooth.)

*Case XXIII., Tuberculosis of the Liver.*—Henry Victor, eighteen months old, entered Tenon Hospital, service of M. Gérin-Roze, August 11, 1882. The child had been under the care of Luc in May for a broncho-pneumonia following measles, and was dismissed un cured. In August there were undoubted signs of softening at the apices, followed by excavation. In September the child was seized with diarrhœa, rapidly emaciated, and died September 15.

At the autopsy the lungs were found infiltrated with tubercles; ascites and tuberculosis of peritoneum; tuberculous ulcerations of the mucous membrane of the ileum. The liver (serous surface) presented an eruption of discrete tuberculous granulations. Section (cross) showed a great number of roundish cavities of the size of a lentil, filled with bile. Microscopic examination showed that the cavities were tubercular. The lesions of the liver were not indicated during life by any special symptom. (Henry Luc.)

#### ABSCESS OF THE LIVER.

Abscess of the liver in children is a comparatively rare affection. The scope of this article will include suppurative inflammation of the liver, and not the general inflammation of the hepatic structure which has been called by various writers hepatitis. Much confusion exists, however, in literature from the use of this term indiscriminately. Descroizilles includes in the article on hepatitis among other varieties a diffused inflammation of the liver, a suppurative inflammation, secondary to enteritis, and another the anatomical appearance of which is the same as that of the liver in new-born infants who die of jaundice. Many writers follow him in this classification, and speak of abscess in the new-born affected with jaundice as most common.

Baumes particularly refers to this, and Bouchut speaks of malignant hepatitis of the new-born, several cases of which he had seen with abscess. Burton quotes Baumes, but confirms the statement of Denis. The latter says that in numerous autopsies he has not confirmed the real existence of this lesion. Bouchut says that one-third of new-born children have hepatitis which until the time of his writing (1867) had been described under the name of jaundice. The title of his article is Hepatitis, which he divides into the simple, malignant, chronic, and traumatic forms. The simple form is the common icterus of the new-born. The malignant form, or icterus gravis, is the variety which Baumes and Martin of Lyons refer to, in which small abscesses were found in the liver. By the chronic form he apparently means hypertrophic or syphilitic cirrhosis. The traumatic variety includes abscess of the liver as we are about to consider it. He quotes the case of Renaud, which we have included in our table, as an example of this variety of hepatitis. Fabre declares that one of the above-mentioned writers, Baumes, made the diagnosis of abscess during life, but did not confirm it by an autopsy. He doubts the existence of abscess of the liver.

The following remarks on abscess of the liver are based upon an analytical study of thirty-four cases of this affection collected from the literature of this disease. The writer is indebted to the article of Bernhard on abscess of the liver in children for much valuable information. It is the most exhaustive paper that has been presented on this subject. It includes an account of three cases, and a critical study of thirteen more reported by different observers. The systematic article of Birch-Hirschfeld in Gerhardt's Hand-Book contains also much valuable information.

Bertrand first speaks of the rarity of abscess of the liver in children, describes abscess of the liver in the new-born, and then studies the collected cases of suppurative inflammation of the liver. He thinks, first, that the child's organism of itself is less disposed to suppurative inflammation of the liver than that of adults; second, that nearly all the etiological factors which lead to this disease in adults may also be effective in children, except those arising from diseases of the bile-ducts. His conclusions regarding the symptoms will be given under that heading in this article, as well as his remarks on the diagnosis. Birch-Hirschfeld considers abscess of the liver to be due to four general causes: first, contusions; second, metastasis or pyæmia; third, tropical causes; fourth, irritation of worms.

After a consideration of the frequency of abscess of the liver in children as first discussed by various authorities, we will consider the subject in a systematic manner.

**Frequency.**—As intimated above, it has been considered rare in children. Rouis speaks of its prevalence in Algiers: of two hundred and fifty-two persons with abscess of the liver, he found only one less than twelve years old; the next in age was a French soldier eighteen years old. Unfortunately, the histories of these cases are not given. Annesley, in his work on the diseases of India, states that the drummer-boys in the

English army rarely, if ever, develop abscess of the liver. Bernhard refers to the association of abscess of the liver in adults with typhlitis and perityphlitis as the most common form seen in Germany, but no such case has hitherto been reported as occurring in a child, and, in general, cases are extremely rare in which the abscess follows pylophlebitis. Cheevers, in his "Commentary on the Diseases of India," writes exhaustively of abscess of the liver, and states that he has never seen hepatitis or liver-abscess in childhood, and that in the four years ending 1883 there occurred among the soldiers' children throughout India a total of thirteen cases of hepatitis with only one death. He further observes that hepatic abscess, presumably idiopathic, when it occurs in very early life is probably of tubercular origin. Morehead showed that the ratio of hepatitis in children was, when he wrote (1860), in "Bengal 0.05 and in Madras 0.3 of strength." He cited the returns of the Byculla schools as proving the rarity of the disease. In Bombay, at the same time of life, the admissions in seventeen years were nine, with one death, out of from two hundred and fifty to three hundred children. Surgeon-General Macpherson for the four years ending 1853 shows that one-twentieth of one per cent. of the soldiers' children had acute inflammation of the liver, with no death. Cheevers could only find accounts of three cases of hepatic abscess in children: first, a child of seventeen months; second, a European child of three years and four months; third, a Parsee child of ten years. Blaney in the statistics of diseases treated at the Bombay European General Hospital, published by Morehead and Stovell, was unable to find a single case of hepatitis in a child. Waring, in a table of two hundred and twenty-seven cases, noted the occurrence of liver-abscess only after the sixteenth year, never having seen a case under that period. Murchison, Frerichs, and others corroborate this observation. We have been able to collect thirty-four cases under fifteen years.

**ABSCESS IN THE NEW-BORN.**—This has been previously referred to and the opinions of some authors quoted. While by some it is thought to be very prevalent, others doubt its existence. Mildner in two hundred sections found inflammation of the umbilical vein forty-six times, thirteen times with phlebitis alone and fourteen times with phlebitis and arteritis of the umbilical vessels. Bernhard thinks that the latter is more frequent than the former when it arises from infection of the navel. Hennig believes that the danger of thrombosis and embolism of the umbilical vein is greatly over-estimated, because the vein of all the fetal passages is the first to dry up and not rarely is narrowed at birth. He thinks that softened thrombi are only rarely introduced through the ductus venosus into the vena cava. He believes the presence of thrombi at the point of issue in the umbilical vein into the portal vein occurring so frequently and singly is proof of the, for the most part, autochthonous origin of liver-abscess. Hecker and Buhl do not share this opinion (Mildner). Bonchut mentions the previously noted observations of Baumes and others, who observed several cases of multiple suppuration in the liver, partly with and partly with-

out abscess-formation. Birch-Hirschfeld found miliary abscess in the liver four times in four hundred and ten autopsies upon new-born children. Ritchie describes a case of liver-abscess holding about one and a half ounces of pus. The abscess was on the lower surface of the liver, principally on the right lobe; the umbilical vein was involved. Kraschutsky reports thirteen cases of inflammation of the umbilical vessels without changes in the liver. Runge reports forty cases with nineteen autopsies without changes in the liver, and in all of the nineteen cases the umbilical artery was diseased.

It appears, therefore, that from infection of the navel the new-born child may have inflammation of the umbilical vein and of the umbilical artery, separately or combined, and that only in a very small proportion of these cases abscess of the liver may occur. The writer saw a case of umbilical arteritis in an infant who died on the tenth day after its birth. The cord bled several times, requiring frequent ligatures, which were done by an unclean midwife. The child was ill, but no systemic symptoms save fever were observed until the fourth day after birth, when a light jaundice supervened. On the sixth day the metatarso-phalangeal joint of the index finger became inflamed. The elbow-joint of the same side, the right, was also seen to be inflamed within twenty-four hours. The child died on the tenth day, of convulsions, apparently due to high temperature. At the autopsy suppurative inflammation of the joints, and inflammation and suppuration of the umbilical artery, were found. The heart, liver, and lungs were normal.

**Etiology.**—Of the thirty-four cases of abscess of the liver under fifteen years which we have analyzed, the youngest child was one year old. The average age was a little over nine years. Of the thirty-three cases in which the sex was given, fifteen were girls and eighteen boys. Age and sex have no etiological value. The most frequent cause assigned is injury, which was observed in eight cases. In some the causative influence of injury is doubtful, and in others it may have been assumed in the absence of a cause that could be definitely demonstrated. In Starr's case two causes may have been operative,—either injury or round-worms. The next most frequent cause of the tabulated cases appears to be round-worms which have wandered from the small intestine into the bile-ducts and thence set up inflammation of the liver. In seven cases they were undoubtedly the cause, and in one (Starr's) they were a possible cause. In the remaining eighteen cases the abscess appears to have arisen secondarily to a pylephlebitis in four cases, to an umbilical phlebitis once, while twice it was pyæmic, and once each it was secondary to pelvic peritonitis, dysentery, perityphlitis, malarial fever, and tuberculosis of the lungs. In six of the cases the cause is not stated. It is thus seen in this series of cases, collected from the literature of the German, French, English, and American writers on this subject, and hence from cases in many countries, that the general conditions which appear to be so influential in certain countries in the development

of abscess of the liver in adults do not obtain in children. Atmospheric influence, temperature, climate, and habits of life need not therefore be considered as etiological factors in abscess of this time of life.

Of the traumatic cases we find a fall striking on the right side, a blow with the fist, or a fall upon a sharp corner of a chair as the direct cause of the inflammation. In one case (31) a boy was lying upon his abdomen on a sled, when another boy fell on him. Suppurative inflammation of the liver developed shortly afterwards. The occurrence of ascariides as a cause is of interest, and its frequency is particularly noticeable. In two cases indicated their association was doubtful. They had been found in the intestinal canal after death or were passed by the rectum during the illness, and, as no other cause existed, the attending physician thought their presence sufficient explanation of the cause of the inflammation. In the instances in which they have been noted as positive factors (12, 13, 14, 15, 25) they were found in the abscess or the liver-structure after death. They had given rise during life to no symptoms which would have caused their presence to be suspected.

The cases following pylephlebitis were due to portal emboli, and in their origin and mode of development were similar to such cases in adults. In one the pylephlebitis was secondary to perityphlitis; in one it apparently followed typhoid fever. In the pyæmic cases, so called, pelvic peritonitis preceded the vein-inflammation in one, rupture of the vermiform appendix in another, and an abscess on the left hip in the third. Dysentery preceded the abscess in one case only (2). A history of exposure to malaria in Africa, without other obvious reason, makes it probable that the same influences that operate in adults to produce tropical abscess were the cause of the suppuration in this rare case. Diarrhoea continued during the two weeks prior to the development of the local symptoms in the case of Dulles, but it cannot be said whether it bore any causal relation. The primary abscess could not be ascertained in Legg's case, but numerous abscesses were seen at the autopsy throughout the abdominal cavity, and the scar of a healed abscess was observed on the upper surface of the right lobe of the liver. The case of umbilical phlebitis is obscure, although the possible primary abscess was in the thymus gland. The case which presented during life the symptoms of phthisis only (33) is also of obscure origin. It had been referred to by Berton as one of tubercle of the liver, a condition scarcely possible.

The case that followed typhoid fever (27) is worthy of further notice, on account of the rarity of such a sequel either in childhood or in adult life. The intestinal ulceration had healed, but the glands, which are frequently affected in typhoid, had suppurated and primarily infected the portal vein.

**Symptomatology.**—The symptoms of abscess of the liver are almost always, and particularly in the pyæmic, or metastatic, form, associated with the symptoms of the primary disease, and hence are often masked by them. Indeed, the mode of onset, the progress, and the duration depend largely upon the cause of the inflammation. If, in cases the symptoms of which

indicate local purulent inflammation in the portal area, pain arises in the liver region, increased by pressure, and especially if this is associated with the development of a painful tumor, which presents the physical characters of an abscess, in all probability the liver has become secondarily infected.

In the traumatic forms, of which six examples are given, either the symptoms developed within a few days after the receipt of the injury, or any inflammatory process was quiescent and without local symptoms for several days or weeks. In one case (16), after a fall, in which the right side was struck, there were no symptoms until a tumor was detected six weeks subsequently. In another, after a blow, pain and other inflammatory symptoms developed immediately, and on the fourth day jaundice. In another (18), the fall took place four weeks before the symptoms arose. In one (30), the injury took place in August, and in October the patient began to complain of hectic symptoms, indicating the presence of pus. So, too, in another (1), the fall occurred months previous to development of the symptoms. The long interval between the injury and the local symptoms is not incompatible with our knowledge of the occurrence of inflammation and suppuration in other portions of the body after injury.

The symptoms associated with the presence of ascarides as cause possibly more distinctly simulate the mode of development of a tropical abscess of the liver, particularly if single, than when the abscess arises from other causes. Under these circumstances it is less related to diseases in other portions of the body, is less complicated, and hence its evolution can be studied more readily. In the case of Lebert (13), the patient was taken sick with chill and fever, followed by pain in the right portion of the belly, and attended by diarrhœa. The liver increased in size and became painful, and later pulmonary symptoms, from extension of the abscess, developed. In another (14), after the occurrence of diarrhœa and vomiting in January, the abdomen increased in size, and by March was very tense and sensitive to the slightest pressure, especially over the liver. In another seemingly typical case of single abscess (12), slight fever, abdominal pain, more or less constant, with cramps in the bowels, continued for six weeks. One week later pleurisy of the left side, and five weeks later pleurisy of the right side, with effusion, took place. In still another (11), an attack of pleurisy took place, followed by effusion and attended by remittent fever. No hepatic symptoms were observed, but, on aspiration, serum was drawn from the chest, and pus from what appeared to be a liver-abscess. Prior to death œdema of the right face, eyelid, thorax, and arm occurred.

The case of Bluff (15), in which the abscess was believed to be due to ascarides, continued over a long period of time, and presented symptoms characteristic of these cases of long duration,—intermittent fever, which continued for three months, followed by pain in the epigastrium, gradual enlargement of the abdomen, and subsequently the formation of a fluctuating abscess at the navel which contained "liver-pus."

The case secondary to pelvic peritonitis (32) indicates strikingly the

mode of onset of a suppuration in the upper half of the abdomen, presumably of hepatic origin, and the formation of an abscess not from pylephlebitis, but from contiguity of structure. The chill and high fever, the rapid pulse, the painful and shallow respiration, the development of a bulging over the liver, which previously had been tender, without the occurrence of jaundice, indicated clearly the presence of hepatic abscess, and showed the mode of onset of a possible idiopathic or solitary hepatic abscess. The case of Mall (10) is a rare one. Characteristic chills followed by violent pain over the liver, the occurrence of febrile symptoms and of vomiting, together with light jaundice, enlarged and prominent liver, and a tumor in the right hypochondrium, clearly indicated hepatic abscess, although no cause for it could be ascertained.

A similar case of rapid course is that of Easmon, the origin of which could not be ascertained, although it was probably similar to the tropical abscess.

The study of the individual symptoms of abscess in children reveals some points of considerable interest. In the cases which we have analyzed, pain, enlargement of the liver, the presence of a tumor, fever, with or without chills, gastro-intestinal and pulmonary symptoms, are those of most frequent occurrence. These symptoms are both local and general.

*Pain.*—In the tabulated cases, pain or tenderness over the liver was mentioned twenty times, although it is probably present in greater or less degree in every case. It was usually seated in the right hypochondrium or liver region (fifteen cases). In five cases the pain was abdominal, being described as occurring in the caecal region, in the belly, in the bowels, at the epigastrium, and about the umbilicus. In the traumatic cases, of course, it was the most constant symptom, was more or less violent, and was always increased by pressure. In two instances it extended to, or was only noticed in, the right shoulder.

*Enlargement of the Liver.*—The liver was enlarged in twelve cases, and in all instances the enlargement was downward. With the enlargement there was also sensitiveness on pressure and generally the occurrence of a distinct tumor.

*Tumor.*—The presence of a tumor was distinctly mentioned in nine cases, the character not being noteworthy; and swelling in the right hypochondrium or belly in ten cases. In most instances the tumor was located as just indicated. In one (Renaud's) it appeared as a round, fluctuating, and pulsating tumor, over which the abdominal wall was gangrenous. In another (27), an elastic tumor at the lower edge of the ribs of the right side, non-fluctuating, was described. In another, a small painful elevation could be detected on the anterior surface of the liver, which was double the normal size. In another it was simply noted as being found in the right side of the abdomen. In Dulles's case (12) the tumor developed at the edge of the ribs eleven days after the symptoms began, and was fluctuating. In another, a few days after the liver was found to be enlarged, two tumors the size of goose-eggs were detected on its surface. In Legg's case (23) the abscess



was located between the umbilicus and the epigastrium. In Wendroth's case there was a tumor the size of a hen's egg in the right hypochondrium.

The cases due to ascarides, curiously, were not attended with the development of localized tumor. In all of them the notes state simply that the liver was enlarged or the abdomen swollen. Nearly all the traumatic cases were attended by tumor-formation. In Case 1, there was a tumor in the right hypochondrium, with bulging of the ribs, but no fluctuation. In Sheets's case the tumor appeared in the right side in the lower part of the chest, and in Drechsler's case a hard swelling the size of a hen's egg was detected in the hepatic region.

The pyæmic cases were usually attended by the presence of a tumor, while in some instances two or three tumors were detected. In each of the three cases of pylephlebitis a tumor existed. In character the tumors were not unlike those of abscess-formation in other regions. In a considerable number of instances fluctuation could not be elicited, but the reason for this is obvious. The development of the tumor was usually gradual, and took place at variable intervals after the occurrence of pain and other local phenomena, and sometimes a long time after the probable cause of the disease.

*Fever.*—Just as pain was mentioned only twenty times in the series of tabulated cases, although it is probably present in greater or less degree in all cases, so fever was noted or its existence implied in twenty-four cases only. In nearly all the fever was of the hectic, pyæmic, or intermitting type, and was usually accompanied with chills. Sometimes the initial chill alone occurred in the course of the disease; again, and indeed frequently, irregular daily chills took place. The cause of the suppuration did not influence the character of the fever. It was as markedly intermitting in the traumatic as in the metastatic variety.

Often the temperature at night would be as high as  $104^{\circ}$ – $105^{\circ}$  F., but in a few instances slight fever only was said to be present. Most characteristic was the occurrence of sweats, usually with the chills and febrile paroxysms: they were extremely profuse and exhausting.

*Gastro-Intestinal Symptoms.*—The coated tongue and loss of appetite of the inflammatory process were usually present, as would be expected. Vomiting, however, was a more frequent gastric complication than is commonly supposed. It did not occur at any special stage of the disease. It is noteworthy that it did not occur in the pyæmic forms nor in the varieties associated with pylephlebitis, nor did it assume any particular characters.

Diarrhœa was also of frequent occurrence, and it, too, did not arise in the pyæmic varieties of suppuration. In eight of the thirty-four cases it was a marked symptom. An enteritis or entero-colitis was associated with the hepatic abscess in some cases, as the discharges were mucous, muco-purulent, or bloody. Five of the eight cases in which diarrhœa was a marked symptom were associated with ascarides, which were believed to be the cause of the hepatic suppuration.

Constipation was said to have occurred in a number of cases, but it is without significance.

In the cases due to ascarides these parasites were in several instances found in the stools and in the vomited matter.

*Jaundice.*—Jaundice is not looked upon as a common symptom in hepatic abscess. It was mentioned in six cases. In two cases of traumatic and two of pyæmic origin, and in two the causes of which were uncertain, it occurred in a slight form (9), or was general (29), or was without special description. The occurrence of jaundice depends upon compression or catarrhal inflammation of the gall-ducts.

*Pulmonary Symptoms.*—In eight cases symptoms due to extension of inflammation to the adjacent respiratory organs were recorded. Pleurisy was most frequent. Pneumonia occurred in one case, and pneumothorax in another.

Naturally, short and interrupted breathing, on account of pain on respiratory movement, occurs, while a short hacking cough often is most persistent. In five of the cases of hepatic abscess caused by round-worms, pulmonary symptoms were most marked, while in all the other cases combined this complication occurred only three times. In one case pleurisy developed because of rupture of the abscess into the pleura; but in the other cases the pulmonary symptoms arose from extension of inflammation by continuity of structure.

*Miscellaneous Symptoms.*—It is almost needless to say that loss of flesh and strength took place in a number of cases. Cerebral symptoms—convulsions, delirium, and stupor—also occurred during the course of the disease in a few instances. The high temperature was believed to be the cause of these phenomena. Hiccough, due to inflammation of the diaphragm, may occur, although it is not recorded in any cases of hepatic abscess in children. The position which the patient assumes is spoken of in accounts of the disease in adults. No particular note has been made of the decubitus in children. The same may be said of the appearance of the countenance, said to be quite characteristic in tropical abscess of adults (Cheever).

*Complications.*—The complications are due to the nature of the primary disease, when the abscess is metastatic; or to inflammation of the organs adjacent to the liver, either by contiguity or because of the direction in which the abscess tends to discharge. Acute endocarditis was associated with a case of pyæmic origin (25). Pleurisy and peritonitis are occasional attendants. In three cases of the thirty-four tabulated the former occurred, and in four the latter. It is quite certain that the bursting of the abscess into cavities or into other viscera does not occur in children so frequently as in adults. The accident occurred once (13) in the tabulated cases.

*Duration and Issue.*—Only an approximation of the duration of the disease can be arrived at. In the series we have analyzed the average duration is about six weeks. In nine cases it appeared to range from seven to forty days, and in four, from three to eleven months.

In all forms the duration was variable. This is especially true of the pyæmic varieties. Birch-Hirschfeld remarks that idiopathic abscess usually results in death at the end of a few weeks, but at times is subacute, and not rarely runs a chronic course, even lasting a year. We cannot confirm the latter portion of the statement from the collected facts.

The duration of the traumatic cases varied also. Löschner's second case (17) died thirteen days after the injury, Renaud's<sup>1</sup> little patient died seventeen days after, and Constant's died in the seventh week.

In cases in which recovery occurs, all symptoms disappear in at least eight weeks (Mall's case).

The issue was favorable in twelve of the thirty-four cases. Operative treatment contributed largely to the favorable termination, for of thirteen cases that were submitted to some form of operation, eleven recovered, unaided nature alone being credited with the recovery of one out of the twelve.

The cases that terminated in recovery were of traumatic origin, or arose from the irritation of worms. The abscess, in other words, was single, or at least not more than two abscesses were present.

**Prognosis.**—The prognosis is not more favorable than in adults. The recent developments in operative measures for the relief of abdominal disease, and the success which Tait, Mayo Robinson, Thornton, and others have met with in dealing with the surgery of the liver, encourage the belief that death from single abscess of the liver will be the exception in the future.

Notwithstanding the observation of Birch-Hirschfeld, that the traumatic cases (three) which he analyzed ended fatally, we believe success will uniformly attend operations for these cases. Thierfelder collected, from the literature of the last thirty years, twelve cases of traumatic hepatitis, with seven recoveries.

Hepatic abscess secondary to pylephlebitis is often fatal, and when of pyæmic origin it is always so.

**Morbid Anatomy.**—Space need not be taken up with a discussion of the anatomical appearances of hepatic abscess in children. They do not differ from the appearances in adults. It may be of interest to note only the relative frequency and association of the multiple and the solitary abscess as seen in children. Briefly, it may be said that a single abscess was found in all the traumatic cases (eight) of the tabulated list, one—or at most two—in the cases due to ascarides (eight), and one in the cases of pylephlebitis. Multiple abscesses (three or more in number) were found in thirteen cases.

The morbid anatomy of the antecedent and associated pathological changes is well known.

**Diagnosis.**—We are concerned in the early detection of hepatic abscess, in the recognition, for the purpose of treatment, of the special variety of inflammation, and in the estimation of the presence of the grave associated

---

<sup>1</sup> Birch-Hirschfeld erroneously states that in Renaud's case the course of the disease was from March 27, 1850, to January 17, 1851.

inflammations of surrounding structures. Suppuration of the liver must not be confounded with other affections of that organ, notably cancer and hydatid disease, or with abscess of the surrounding viscera, and particularly with abscess between the liver and the diaphragm.

In the recognition of abscess of the liver in childhood, we can frequently associate some definite cause with the suspected inflammation. The progress of subsequent events, with a study of the symptoms collectively rather than individually, aids us in our judgment.

Thus, if in the presence of trauma, or of inflammation and suppuration in other parts of the body, there occurs pain in the region of the liver, with a sensation of weight and fulness, with tenderness on pressure, with a chill or chills followed by fever, with loss of appetite, vomiting, and possibly diarrhœa, we have strong reasons for suspecting the formation of an hepatic abscess. If later the fever assumes a pyæmic or hectic type, with chills, sweats, exhaustion, emaciation, and the local signs of suppuration, our suspicions are confirmed. The occurrence of jaundice, if the cause is probably pyæmic, is a strong affirmative rational symptom. The short duration of the disease is of diagnostic value.

Of the physical signs, enlargement of the liver uniformly, or upward anteriorly; bulging of the ribs; the formation of a tumor in the epigastrium or right hypochondrium connected with the liver; fluctuation of the tumor; and œdema of the skin, or even inflammation of its surface, are to be looked for. It is to be remembered that a large abscess may be present and yet not be demonstrable by physical means.

The use of the exploring needle or aspirator has been referred to in the account of the symptoms. In a suspected case it can be employed. Often by it alone can pus be located. Fenwick relies much for diagnosis on the microscopical characters of the fluid withdrawn, and believes that nearly always hepatic tissue can be recognized in the purulent fluid. His sanguine expectations, however, do not appear to have been confirmed.

By means of exploratory puncture a hydatid tumor can be recognized or the presence of carcinoma determined. Its value in pleural effusions has been dwelt upon already.

Hydatid disease of the liver can be distinguished from abscess by attention to the following phenomena of the former: the long duration of the disease, the absence of pain and of constitutional symptoms, and the peculiar circumstances of its occurrence. A local projection from the general contour of the liver occurs in both; the aspirator reveals the difference in the contents of a tumor. The tumor of abscess has indurated tissue around it, and local inflammation is more likely to be evident on the surface. The characters of a suppurating hydatid cyst and multiple echinococcus have been discussed (p. 445 *et seq.*).

Cancer and abscess of the liver in childhood have symptoms and signs in common. Both are of short duration, both cause enlargement of the liver, and in both fluctuating tumors are observed. In cancer the liver is

of larger size, and more nodules, possibly fluctuating, are detected, but none of them are as painful as the fluctuating projections of an abscess. The abdomen is more increased in size, and the abdominal veins more distinct, in cancer than in abscess. Cachexia attends the former; active constitutional symptoms (hectic) more frequently attend the latter.

The association of pleural effusion or empyema with abscess of the liver frequently makes it difficult to recognize the presence of the latter. The results of percussion, as indicated in a previous section, are important aids to the distinction of hepatic abscess. Bernhard says that in liver-abscess complicated with pleural effusion the limits of dulness can rise higher anteriorly than posteriorly, and, in general, are irregular.

Puncture, with antiseptic precautions, may lead to a diagnosis. Thus, in the upper intercostal spaces, which are dull on percussion, a serous fluid may be withdrawn, and in the lower, pus. Or, if the trocar is plunged deeply, at first it may give exit to pus, but, as it is withdrawn from the abscess to the level of the pleural exudate, serum may be discharged. It is more difficult to differentiate the two conditions when pus is both above and below the diaphragm. The history of the case may be the only method of distinction.

The distinction between pleuritic and pulmonary inflammation and hepatic suppuration has been referred to in discussing the pulmonary symptoms of abscess of the liver, as well as in the preliminary remarks on enlargement of the liver in general. It must not be forgotten that pus from an empyema, if it communicates with a bronchus, is most fetid when evacuated by trocar, and that during such evacuation air may pass through the canula.

Can we distinguish the various forms of hepatic abscess? Multiple abscesses are not amenable to surgical treatment, while many other forms are. The importance of an attempt at the formation of a distinction is apparent.

Traumatic abscess has well-defined symptoms. Local pain, local physical signs of suppuration, enlargement of the liver, and constitutional symptoms clearly show its presence after an injury.

If suppuration is known to be present in the portal area, and the symptoms enumerated above—especially chills and intermittent fever—arise, pylephlebitis and hepatic abscess are likely to be present. In the tabulated cases gastro-intestinal symptoms were absent in the cases due to pylephlebitis.

Davaine<sup>1</sup> writes of six cases in which ascariides caused abscess of the liver, two of which were in children. The most important symptoms of this affection of the liver, he says, are fever, more or less acute pain in the right hypochondrium, icterus, convulsions, vomiting, and diarrhœa. In the cases we have tabulated the detection of the worms by vomiting or purging was noted several times. The occurrence of such vomiting in the course of suspected hepatic abscess would warrant the belief that an abscess from the irritation due to the worms was in progress.

---

<sup>1</sup> *Traité des Entozoaires*, pp. 156-175.

The importance of this aspect of the study of abscess of the liver in childhood has led us to make a comparative study of the symptoms in order to determine, if possible, a means for detecting the different forms. Practically, the traumatic variety and that due to worms could be associated. They alone cause single abscesses. We have, however, divided the thirty-four cases according to cause into four classes,—*i.e.*, cases from (i.) injury (eight), (ii.) worms (eight), (iii.) pyæmia or metastasis (four), and (iv.) miscellaneous. The cases are too few for definite purpose, but some interesting facts have been developed. Only the prominent symptoms are discussed. The Roman numerals above associated with the causes will serve to designate the classes. In some cases the record of symptoms is not complete, hence the analysis is not beyond criticism.

1. Fever: in i., eight times; ii., five times; iii., four times; iv., four times. No particular type was associated with the particular cause.

2. Pain: in i., eight times; ii., twice; iii., once; iv., six times. Pain was characteristic of the traumatic form.

3. Enlarged liver: in i., three times; ii., four times; iii., four times; iv., three times. It was more common with ascariæ and in miscellaneous forms.

4. Tumor: in i., twice; ii., twice; iii., five times (?); iv., four times. Singularly, less common in the traumatic form.

5. Gastro-intestinal symptoms: in i., vomiting twice, constipation twice; ii., diarrhœa five times, vomiting twice; iii., absent; iv., diarrhœa twice, vomiting once. The great frequency of diarrhœa with ascariæ appears to be significant.

6. Jaundice occurred twice in i., iii., and iv., and was absent in ii. Its presence, therefore, was not of much significance.

In the preliminary remarks it was noted that abscess of the abdominal walls and abscess between the liver and the diaphragm simulated abscess of the liver. The distinctions were discussed. To distinguish subdiaphragmatic and hepatic abscess is most difficult,—indeed, well-nigh impossible. The cause of the former Fagge lays stress upon, as of diagnostic value,—namely, direct injury. Both Fagge and Taylor<sup>1</sup> detail interesting cases of abscess between the liver and the diaphragm in children.<sup>2</sup> These abscesses cause the same local symptoms and local signs, have the same associated inflammation of adjacent structures, and burrow in the same way, as hepatic abscess.

<sup>1</sup> Guy's Hospital Reports, Third Series, vol. xix., 1874.

<sup>2</sup> Fagge has collected sixteen such cases, and Frederick Taylor has reported two more. One of Fagge's cases, and both of Taylor's, occurred in children. It would appear from these that the cause is generally a traumatism, and that pleurisy, empyema, pneumonia, and bronchitis, with or without expectoration of blood and pus, are more common than in abscess of the liver. Symptoms of peritonitis are also more pronounced in the former, while symptoms and physical signs, including jaundice, directly referable to the liver are fewer and less precise than in abscess of the liver. The typical physical sign of the latter disease, a rounded, fluctuating, painful, and tender tumor situated in the liver-substance, of course does not exist in the former.

**Treatment.**—The occurrence of twelve recoveries in the thirty-four cases tabulated, in eleven of which operative measures of some sort were resorted to, establishes beyond further discussion the method of treatment to be pursued in cases of abscess of the liver. It is not necessary to reiterate the dangers of non-interference nor to answer the objections against an operation. The table shows that without an operation the patient almost invariably will die. Aspiration or incision, or both, were the means employed to evacuate the abscess.

The cases that Murchison, revised by Brunton, indicates should be operated on are, (1) those in which there is a visible fluctuating tumor; (2), cases with symptoms of hepatic abscess with a distinct tumor; (3), cases with symptoms of abscess with enlargement of the liver and local œdema, or obliteration of an intercostal space, or local pain on pressure or on full inspiration; explore with a fine trocar, and operate if pus is obtained; (4) even without local signs, severe constitutional symptoms warrant exploration with the aspirator; (5) in multiple abscess of the liver, life may be prolonged and suffering relieved by puncture.

Regarding the surgical treatment of hepatic abscesses it may be of interest to note the conclusions reached by Mr. Riekman J. Godlee.<sup>1</sup>

Having decided to relieve the patient,—such decision being based on the exclusion of multiple hepatic abscess, for the relief of which operative measures are scarcely advisable,—the question arises as to the time at which the operation should be performed, and the method of operating. The operation should be performed as soon as pus is known to be present. It may be done by free incision, or by aspiration with a large canula.<sup>2</sup> Free incision, with antiseptic precautions and the introduction of a drainage-tube, appears to be the best and speediest method of treatment. It is not necessary to cause, artificially, adhesions between the liver and the thoracic or abdominal wall. The peritoneum and liver-substance may be stitched together. Tiffany, of Baltimore, successfully evacuated an abscess in this manner.

Before pus has been detected or the exact location of the abscess decided upon, the patient must be treated by local applications, as hot fomentations or poultices, nourishing—preferably liquid—food given, and tonics and stimulants resorted to. Pain must be relieved by opiates, and other symptoms treated as they arise. In general, proper diet, tonics and stimulants, and opiates *pro re nata* meet all the indications, outside of the relief the surgeon can afford.

*Bibliography.*—The following references are in addition to those in the table: Bouchut, E., *Traité pratique des Maladies des Nouveaux-nés*, Paris, 1867; Ashby and Wright, *Diseases of Children*, London, 1889; Descroizilles, *op. cit.*; Fahre, *op. cit.*; Habershon, *Med.-Chir. Trans.*, 1860, xliii. 12; Baginsky, *Lehrbuch der Kinderkrankheiten*, 1887.

<sup>1</sup> British Medical Journal, January 25, 1890.

<sup>2</sup> See Tait, *Hepatic Surgery*, Edinburgh Medical Journal, 1889.

TABLE.

No.	REPORTER.	REFERENCE.	AGE.	SEX.	CAUSE AND SYMPTOMS.	RESULT, COURSE, TREATMENT.	REMARKS.
1	Obre.	Trans. Path. Soc. Lond., iii. 115.	9	F.	Possibly <i>traumatic</i> , from a fall some months previous, not followed by any indications of severe injury. Hectic, pulse 90-140, œdema right leg, convulsive movements right leg, no jaundice. Swelling in right hypochondrium, bulging ribs, no fluctuation.	<i>Death</i> . Aspiration; abscess opened, but opening allowed to close; tumor enlarged, hectic; death eleven days after fulness in side was first noticed.	Cavity containing one and a half pints of pus in right lobe. Pneumonia at right base. No ulceration in bowel. Gall-bladder normal.
2	Moore, N.	Trans. Path. Soc. Lond., xxxiii. 132.	3½	F.	<i>Dysenteric</i> . Had had diarrœa for a year; last two months stools slimy and bloody. In hospital five weeks. Had always lived in London.	<i>Death</i> .	
3	Ritchie, R. P.	Elin. Med. Jour., xii. 181.	1½	F.	<i>Unilateral Phlebitis</i> . For two or three days, ill with vomiting and diarrœa; stools slimy and yellow. Skin sallow; papular syphilitic eruption.	<i>Death</i> , in sixteen days.	Abscess of thymus. Single abscess in right lobe of liver at entrance of umbilical vein. General peritonitis.
4	Fergus, W.	Lancet, 1884, i. 1182.	15	M.	Probable <i>peritiphitis</i> . Of tuberculous family. Aspect sickly; tongue heavily coated, thirst, dryness of mouth; fever, 104.5° F.; urine normal, except abundance of lithates. Stools from two to four a day; no jaundice; frequent perspirations and rigors. Abdomen swollen. Liver enlarged. Pain chiefly in cœcal region.	<i>Death</i> .	General peritonitis. Abscess two-thirds the bulk of the liver. Condition of cœcum not mentioned.
5	Easton, J. F.	Lancet, 1887, ii. 310.	3½	F.	<i>Malarial</i> . Patient lived in Gold Coast Colony, Africa. Swelling noted three weeks after bilious malarial fever. Rapid loss of flesh and vomiting. Large tense tumor occupying right hypochondrium.	<i>Recovery</i> , after several aspirations.	
6	West, S.	Med. Press and Circ., 1884, xxxvii. 277.	11	M.	Never lived out of London. Rigor followed by pain in right hypochondrium. Extremely ill. Temperature, 105° F. No physical signs mentioned.	<i>Recovery</i> . One month from onset, large abscess aspirated. Four days later, incision, second abscess opened. Two weeks later, last two abscesses again	Convalescence retarded by abscess of abdominal wall, which was opened.



<p>opened and drained. One month later, fresh abscess discovered and opened. Duration about three months.</p>	<p><i>Recovery.</i> Abscess incised on twenty-fifth day. Pus continued to discharge for one month. Patient then discharged well. Duration about eight weeks.</p>	<p><i>Recovery.</i> Poulitices followed by aspiration. Duration eight weeks.</p>	<p><i>Recovery.</i> Poulitices followed by incision. Pus contained bile and liver-tissue. Probe passed four inches. Duration about five weeks.</p>	<p><i>Recovery.</i> Abscess opened about five weeks (thirty-six days) from first symptom. Three weeks later, opening closed. Duration eight weeks.</p>	
<p>Parsee boy, born in India. Twenty-four days before he was seen he was seized with pain in right side, accompanied by continued fever. Thirst, bowels constipated, urine scanty and high colored. Liver much enlarged, distinct fluctuation over anterior surface of right lobe.</p>	<p>Possibly <i>traumatic</i>, possibly from <i>round-worms</i>. Lived in a malarious district. Well up to one week before admission. Pain about umbilicus. Castor oil brought away from twenty to thirty round-worms. Restlessness; some fever; no jaundice; bowels moved daily, passage hard and small. Swelling of abdomen, later tenderness and deep-seated fluctuation.</p>	<p>Apparently <i>traumatic</i>, from pressure and strain. Pain in right hypochondrium. Evening fever; thirst; constipation; chilliness and rigors. One attack of vomiting; loss of flesh. Swelling over liver, later resembling a carbuncle. No fluctuation.</p>	<p>Taken sick with severe chills followed by violent pains in liver. Six days later, febrile symptoms, frequent bilious vomiting; painful swelling in right hypochondrium, tenderness; stools sluggish; urine scanty and dark-colored. Whole body slightly icteric. Liver enlarged and prominent. On sixteenth day, signs of abscess.</p>		
<p>7 Miller, H. Trans. Med. and Phys. Soc. Bombay, 1849-50, 313.</p>	<p>M. 10</p>	<p>8 Starr, L. Trans. Coll. Phys. Phila., 1876, iii. 17.</p>	<p>M. 5</p>	<p>9 Vogler, G. W. Jour. Amer. Med. Assoc., 1887, viii. 275.</p>	<p>F. 12</p>
<p>10 Mall, C. D. Wiener Med. Presse, 1872, xiv. 636.</p>	<p>F. 12</p>				

TABLE.—Continued.

No.	REPORTER.	REFERENCE.	AGE.	SEX.	CAUSE AND SYMPTOMS.	RESULT, COURSE, TREATMENT.	REMARKS.
11	Bernhard, A. (Kohlt's Clinic).	Jahr. f. Kind., N. F., 1886, xxv. 303- 50.	13	M.	<i>Ascarides?</i> Taken acutely sick with symptoms of pleurisy; effusion; remittent fever. Aspiration withdrew grayish-green, feculent-smelling pus; subsequent resection. Pleural effusion serous; pus came from liver-abscess. Edema of right face, eyelid, thorax, and arm. Death three days after operation.	<i>Death.</i> Autopsy: large liver-abscess toward diaphragm; duodenum contained a large number of round-worms. Duration six weeks.	
12	Scheu- thauer (quoted by Bern- hard).	Jahr. f. Kind., 1879, xlii. 63.	4	M.	<i>Ascarides.</i> Sick six weeks with slight fever, pain and cramps in bowels; one week later, left-sided pleurisy; four days later, diarrhoeic stools containing ascarides; five weeks later, right-sided pleurisy and effusion.	<i>Death.</i> Autopsy: right-sided empyema. Two abscesses in liver; in one is an ascaris, and in ductus cholechilus there are several; they are scarcely true abscesses. Duration nine weeks.	
13	Von Le- bert (quoted by Bern- hard from Gen- Hardt's Hand- buch).	Jahr. f. Kind., 1886, xxv. 303-50.	15	F.	<i>Ascarides.</i> Taken sick with chill, fever, violent pain in right portion of belly, and diarrhoea. Liver enlarged and painful. Fourteen days later, cough; two days later, rejection of ascarides by vomiting and by stool. Eight days later, right-sided pneumothorax began to develop.	<i>Death.</i> Autopsy: right pneumothorax. Bile-ducts much dilated and containing ascarides; large abscess of liver which had broken through the diaphragm. Several abscesses communicate with bile-ducts, and two contain macerated ascarides, one especially soft and decomposed. Ascarides in intestines. Duration five weeks.	
14	Davaigne.	Traité des En- tozoaires, pp. 156-175 (quoted by Bernhard, l. c.).	. . .	M.	<i>Ascarides.</i> End of January, 1829, diarrhoea, vomiting, general weakness. March 18, belly tense, enlarged, sensitive to slightest pressure, especially over liver. Pneumonia.	<i>Death.</i> Autopsy: pneumonia. Thirty ascarides united in small balls in small intestine. Three pus-cavities in liver, one containing an ascaris. No	

15	Bluf.	Medicin. An- nalen, 1885, Bd. I., Heft 3, S. 472 (quoted by Bernhard, <i>l. c.</i> ).	15	F.	<i>Ascariides.</i> In July, 1834, intermittent fever, disappeared about October 18; about October 15, pain in epigastrium; ascariides found in stools. In evening, slight chills and consecutive fever. Toward December, swelling of belly, later of thighs and legs. Fluctuation at navel; lanced; four quarts of "liver-pus" obtained, the flow increased by stroking from liver towards navel.	communication with bile- ducts demonstrated. Du- ration three months.
16	Renaud.	L'Union Méd., 1851, No. 37 (quoted by Bernhard, <i>l. c.</i> ).	1½	.	<i>Traumatic.</i> Fell and struck on right hypo- chondrium. Tumor noted in six weeks. No jaundice and no digestive disturbance. Tumor in right hypocondrium, fluctuating and pulsating.	<i>Recovery.</i> Might have been a sacculated perito- neal abscess (Bernhard). Duration six months.
17	Löschner.	Jahr. f. Kind., 1860, S. 70 (quoted by Bernhard, <i>l. c.</i> ).	11	M.	<i>Traumatic.</i> Struck with fist in right hypo- chondrium. Pain; febrile symptoms; cough. Fourth day, icterus; right-sided pleurisy. Sixth day, shivering and great heat. Eighth day, chill. In upper part of belly was a resisting, very painful spot, corresponding with the liver.	<i>Death.</i> Abscess opened by incision. Fistula formed and wound be- came gangrenous. Au- topsy: abscess in upper anterior surface, and sev- eral small ones in lower and external third. Du- ration seventeen days.
18	Baude- loque.	Schmidt's Jahr., 1834, iv. (quoted by Bern- hard, <i>l. c.</i> ).	11	M.	<i>Traumatic?</i> Said to have sustained a fall four weeks before. The last survivor of a tuberculous family. Had phthisical symp- toms.	<i>Death.</i> Autopsy: abscess in upper half of right lobe. Right-sided fibrino- purulent pleurisy. Dura- tion thirteen days.

*Death.* Autopsy: liver somewhat enlarged. In right lobe were from twelve to fifteen pus-cavities. Bile-ducts normal. Phthisis. Duration six weeks.

TABLE.—Continued.

No.	REPORTER.	REFERENCE.	AGE.	SEX.	CAUSE AND SYMPTOMS.	RESULT, COURSE, TREATMENT.	REMARKS.
19	Romberg.	Casper's Wechenschrift, No. 18, S. 292 (quoted by Bernhard, <i>l. c.</i> ).	5	F.	Icterus; fever; pain in right hypochondrium; thirst; constipation. Salivary color of urine.	<i>Death.</i> Autopsy: liver not enlarged; surface of right lobe contained a number of small foci of suppuration. Duration seven days.	
20	Wendroth.	Med. Zeitung, 1834, No. 34 (quoted by Bernhard, <i>l. c.</i> ).	3	F.	Suffered from birth with a skin-eruption, on the disappearance of which a tumor the size of a hen's egg formed in right hypochondrium. No fluctuation. In ten days sudden chill, evening fever, sweats.	<i>Recovery.</i> Relations of the tumor examined by the finger through opening, —undoubtedly liver. Tumor lanced. Duration four weeks.	
21	Dulles, C. W.	Phila. Med. Times, 1878, -79, ix. 300.	12	M.	Diarrhoea two weeks; then constipation; patient gradually became yellow. Pain at edge of ribs. In about eleven days tumor; fluctuation.	<i>Recovery.</i> Aspiration; incision. Duration about six weeks.	
22	Bach, J. A.	Therap. Gaz., January 15, 1887.	9	M.	Badly bruised on left hip, followed by abscess. On tenth day great enlargement of liver; a few days later two tumors size of goose-eggs.	<i>Recovery.</i> Poulitice, aspiration, incision. In three days, abscess of left lobe of liver treated in the same way.	
23	J. Wickham Legg.	St. Barthol. Hosp. Rep., 1875, xi. 85.	5	F.	Had had abscess in groin eighteen months before, which broke and healed. Admitted June 30, 1874, for abscess; opened the umbilicus and the epigastrium; wound healed and child dismissed. Re-entered September 21, worse.	<i>Death.</i> Autopsy: numerous abscesses in abdominal cavity. Abscess in posterior part of left lobe of liver. Numerous abscesses elsewhere. Scar on upper surface of right lobe, possibly from healed abscess where the latter had been opened. Duration probably some months.	

24	Murehison.	Clin. Lec. Dis. of Liver, 1877, p. 171.	15	M.	<i>Pyæmic.</i> Symptoms secondary to rupture of vermiform appendix. In seventeen days the liver was found to be enlarged and tender. No rigors, but temperature subject to great and sudden variations; sweats.	<i>Death.</i> Autopsy: healed inflammation of appendix. Both lobes of liver studded with numerous small circumscribed abscesses. Glands in fissure of liver enlarged and suppurating. Other organs healthy. Duration about ten weeks.	No history of traumatism. Endocarditis developed late in disease.
25	Sinuhold.	Jahrbuch f. Kind., 1879, xiii. 288.	5½	F.	<i>Ascariæ.</i> Bilious vomiting, pain in belly, passage of round-worms by mouth and anus. Liver enlarged, tender; thirst, with frequent chills, followed by fever and sweat.	<i>Death</i> on twentieth day. Autopsy: liver enlarged, —seven inches long, eleven inches broad. Several abscesses in liver.	
26	Bernhard, A.	Jahrbuch f. Kind., N. F., 1886, xxv. 302-350.	10	M.	Secondary to <i>pyelophlebitis</i> from perityphlitis. October 27, 1884, symptoms of perityphlitis; twenty-two days later, prominence in right side of belly first seen; fever pyæmic, intermittent; chills.	<i>Death</i> on twenty-fifth day from beginning of disease. Autopsy: fibrous and purulent peritonitis, secondary to pyelophlebitis. Series of walnut-sized abscesses on upper surface of right and lower surface of left lobe.	
27	Bernhard, A.	Jahrbuch f. Kind., N. F., 1886, xxv. 303-350.	12	M.	Secondary to <i>pyelophlebitis</i> from typhoid fever. On twenty-seventh day of typhoid fever, a chill; two days later, violent pain in region of liver. Elastic tumor at lower edge of ribs, right side. No fluctuation. Fever intermittent. Chill not repeated.	<i>Death</i> on thirty-fifth day of disease. Autopsy: healed typhoid ulcers in bowel, and pyelophlebitic abscesses proceeding from suppurating glands of ileo-cæcal cord.	
28	Burder.	Lancet, 1874, ii. 552.	9	M.	Secondary to <i>pyelophlebitis</i> . Typhoid symptoms, with chills and jaundice.	<i>Death</i> on seventeenth day. Autopsy: ileum and cæcum full of ulcers,—superficial, with no ragged edges in Peyer's patches. Liver a mass of small abscesses.	Burder does not think the patient had typhoid fever.

TABLE E.—Continued.

No.	REPORTER.	REFERENCE.	AGE.	SEX.	CAUSE AND SYMPTOMS.	RESULT, COURSE, TREATMENT.	REMARKS.
29	Löschner.	Jahrbuch f. Kind., 1859, S. 140.	10	F.	Secondary to <i>pylophlebitis</i> . Began with general jaundice. After seven weeks, could not leave bed. Frequent epistaxis. Much emaciation. Liver enlarged—double normal size. Small, painful elevation on anterior surface. Stools contained bile and blood.	<i>Death</i> in six weeks. Autopsy: large liver full of minute abscesses.	Löschner believes pylophlebitis was secondary to stasis in portal circulation, arising from obstruction of bile-ducts. But, Bernhard asks, why should stasis in this case give rise to suppuration? Patient in hospital under observation only five days.
30	Sheets, L. D.	Cincin. Med. Observer, 1857, ii. 9-11.	12	M.	<i>Traumatic</i> . Fell upon a sharp corner of a chair, in August, 1855, and probably fractured a rib. Pain was severe, but subsided in a few days. In October, was seized with chills, which were soon broken up, but health was not restored. In March following, a prominence was discovered in the right side and lower part of chest; later, decided fulness. Liver enlarged, ribs bulging; feet slightly oedematous, bowels costive, tongue furred, appetite poor.	<i>Recovery</i> . Incision between ninth and tenth ribs April 10. Abdominal fluid, blood, and pus evacuated. On September 14, a piece of broken rib was removed by the patient, and a few weeks later the discharge ceased and the wound closed.	A fracture of the rib was unsuspected at the time of the accident, but the author thinks the abscess of the liver was secondary to the fractured rib, and was produced by irritation. Duration uncertain, probably about eleven months.
31	Drechsler.	St. Louis Med. and Surg. Jour., 1869, N. S., vi. 39-41.	13	M.	<i>Traumatic</i> . Was lying upon his belly on a sled, when another boy fell on him. Since then pain in right side. Subsequently, vomiting, chill, high fever, dry skin, acute pain in right hepatic region. Physical signs: dullness on percussion, and a small hard swelling about the size of a hen's egg.	<i>Death</i> . When apparently convalescent, February 13, he coughed up about a pint of bloody pus, apparently from the right lung.	The case was supposed to be one of acute congestion of the liver. There was no autopsy.
32	Dunn, T. D.	Univ. Med. Mag., November, 1889.	14	F.	Believed to be secondary to a <i>pelvic peritonitis</i> . Chill, high fever, rapid pulse, painful and shallow respiration, tenderness over liver. Later, rigors and sweats, increased hepatic swelling and tenderness; respiration shallow, quiet, and painful. No jaundice; no	<i>Recovery</i> . Aspiration, followed by improvement in symptoms. Night-sweats continued, but with no rigors. Emaciation marked. Subsequent re-	Microscopical examination of the pus disclosed the presence of blood, pus-cells, shreds of tissue (organ not mentioned), but no bile or biliary

33	Berton.	Traité prat. des Maladies des Enfants, Paris, 1842, p. 670 (case quoted from Gaz. Méd., March 16, 1834).	11	M.	Had presented all the symptoms of pulmonary phthisis.	<p>filling of abscess and aspiration, and then abscess opened spontaneously through puncture. Cavity washed out with carbolic water.</p> <p><i>Death.</i> Autopsy: double pleuro-pneumonia. Bronchial glands hypertrophied but non-tubercular. Liver a little larger than normal, and containing fifteen purulent foci. No jaundice.</p>	<p>pigment. Duration of case, from symptoms believed to be the initial ones of abscess of liver, about forty days. Patient has since borne two children.</p> <p>Case referred to by Berton as one of "tubercle of the liver."</p>
34	Brown.	Trans. Medico-Chirurg. Soc. Edinburgh, 1861, i. 665.	1	F.	<p><i>Ascarides?</i> Subject to diarrhoea for two months, passed worms by bowel, and had bloody stools occasionally. Liver found enlarged when abdomen was examined day before death. Much emaciation.</p>	<p><i>Death.</i> Autopsy: deep ulceration of the size of a dollar in both lobes of the liver. In right lobe immediately under margin of ribs was an abscess containing about three ounces of a bloody matter, rather thin in consistence. Stomach, bowels, and other viscera healthy.</p>	

# CONTRACTIONS OF THE LIVER:

## CIRRHOISIS (ATROPHIC AND HYPERTROPHIC), ACUTE YELLOW ATROPHY, AND ASCITES.

BY MARCUS P. HATFIELD, M.D.

---

### CIRRHOISIS OF THE LIVER.

**Synonymes.**—Cirrhosis hepatis, Chronic interstitial hepatitis, Hob-nailed liver, Drunkard's liver, Gin liver; French, Cirrhose du foie; German, Granulirte Leber.

**Definition.**—Sclerous inflammation of the liver, located either in its fibrous tissue, capillaries, lymphatics, or bile-duets, separately or combined.

**Varieties.**—The simplest division of hepatic cirrhosis is that proposed by George Monroe Smith,—viz. : (1) *Obstructive*, which may be subdivided into (a) biliary, or that arising from impeded bile-flow; (b) static, or that originating in some interference with the flow of blood from the liver; (c) cyanotic. (2) *Irritative*, or that due to the presence of some toxic substance in the blood carried to the liver by the portal vein or the hepatic artery. Under this head may be grouped the cirrhoses which follow alcoholic excess, malaria, syphilis, rickets, scarlatina, etc.

Hepatic cirrhosis is, however, more frequently divided into *atrophic* and *hypertrophic*. The former is so named from the contraction of connective tissue which follows as a secondary result of a previous inflammation and proliferation of the capsule of Glisson or other connective tissue of the liver. Hypertrophic cirrhosis is the biliary cirrhosis of G. M. Smith's subdivision, and is so named on account of an initial stage of increased size of the liver.

According to Hayem, there is a third variety of cirrhosis, originating in the lymphatics, also hypertrophic in form.

Salomon describes a fourth form of cirrhosis, which begins in the arterial system, producing a general arterio-sclerosis, of which interstitial nephritis is one of the more common complications. This form is not common with children.

Carpentier asserts that there is another form of hepatic cirrhosis, characterized by fatty degeneration of the liver parenchyma; but his views seem as faulty as the earlier views of Laennec, who first described cirrhosis as a



special disease of the liver, deriving the name from *cirrhus*, "red," on account of the predominance of this tint in the granulated liver, as it was frequently called at that time. These granulations were by many considered analogous to tubercles, and were known as cirrhoses. Next Andral taught that there were two substances in the liver, a red (vascular) and a yellow (glandular), and that in cirrhosis the red substance atrophies, while the yellow substance hypertrophies. Becquerel (1840), Gubler, Kiernan, Hallmann, Charcot, Dujardin-Beaumez, and others have attentively studied the subject, until it is now clearly understood that cirrhotic inflammation of the liver may originate either in its blood-vessels, in its lymphatics, or in the bile-ducts, and may remain confined to any one of these tissues, or involve them all conjointly; but it will be found always that obstructive cirrhosis is at first monolobular,—that is, the connective tissue grows irregularly, its hypertrophy being confined to certain lobules only. Finally, it may become impossible to differentiate monolobular from multilobular cirrhosis, and in the later stages hypertrophic may closely resemble atrophic cirrhosis.

**Frequency.**—It was formerly taught that hepatic cirrhosis was one of the rarest of the diseases of childhood. Dr. West says that of seventy thousand cases of children's diseases known to him, but four were cirrhosis of the liver. Birch-Hirschfeld says it is extraordinarily rare, Thierfelder calls it "absolutely rare," and Henoeh asserts that it is never fully developed in children. Neurentter puts its frequency at one-tenth of one per cent. of the children brought to him, and Steimer's figures are about the same. Nevertheless, Dr. Palmer Howard has succeeded in collecting more or less complete accounts of sixty-three cases, to which the writer can add ninety-three reported during the past fifty years, making a total of one hundred and fifty-six cases, so that he fully agrees with Eustace Smith in the statement that there is every reason to believe that hepatic cirrhosis is less uncommon with children than is generally thought.

**Age.**—The largest proportion of recorded cases occurred in children between eight and fifteen years old, the majority of cases of alcoholic cirrhosis, naturally, being found in the elder children. Gibbons reports a case of biliary cirrhosis in a child of eleven months, and the writer<sup>1</sup> found it in a child dying on the twelfth day.

**Varieties.**—Their relative frequency is probably about that given by Lancereaux,—viz., of fifty non-syphilitic cases the cirrhosis was atrophic in nineteen, hypertrophic in thirteen, and the liver was of normal size in six; of the remaining cases (twelve) no data are given. Congenital cirrhosis is invariably syphilitic (Birch-Hirschfeld).

Fifteen per cent. of Dr. Palmer Howard's cases were in children known to be addicted to the use of spirits, in eleven per cent. there was a clear history of syphilis, eight per cent. were tuberculous, and the remainder were of unknown etiology.

<sup>1</sup> American Pediatric Society, 1889.

*Sex.*—Dr. Howard's cases seem to show that it is twice as frequent with male as with female children; Birch-Hirschfeld's, exactly the contrary.

*Etiology.*—According to Dr. Lancereaux (Hôpital de Pitié, Paris), there are but three well-established causes of primary cirrhosis of the liver,—viz., (a) alcoholic, (b) malarial, (c) syphilitic. "All other forms of cirrhosis are secondary, arising from other and primary disorders, such as hepatic hyperæmia, due to heart-disease, obstructions to the bile-flow, and cancerous or other infiltrations, all of which show elsewhere their characteristic pathological changes."

In regard to *alcoholic* cirrhosis, its existence in children has been doubted, but there seems to be the best of evidence as to its occurrence, although, from the nature of the case, alcoholic cirrhosis is not often susceptible of direct proof in young children. Frerichs reports that of the thirty-six cases of cirrhosis in children observed by him twelve were known to have been brandy-drinkers. Out of Bamberger's thirty-four cases ten followed brandy-drinking, and ten of Howard's sixty-one cases were traceable to alcohol. In short, about one case in four (thirty-two out of one hundred and thirty-one) of all those reported by the above authors was directly due to alcohol. Nothing, says Strauss, is more natural than the localization of alcoholic cirrhosis, for the alcohol comes directly to the liver by the finer branches of the portal vein and exerts first of all its baneful influence on the points where its contact is most intimate.

*Ptomaine Cirrhosis.*—Peter and Roger, of Paris, have found that the ptomaines and other alkaloid products of retrograde metamorphosis are destroyed in their passage through the liver, since the portal blood contains about twice as much of these substances as the blood coming away from the liver. Moreover, these products when administered subcutaneously are much more virulent than when injected into the portal vein. All these facts seem to prove that the liver acts as a crematory for the destruction of the leucomaines and ptomaines formed within or introduced into the body. Failure to accomplish this constitutes one form of hepatic incompetence, and, in all probability, at last a variety of hepatic cirrhosis, especially in cases predisposed thereto. Howard's cases seem to suggest that such predisposition is often inherited, occurring in several members of the same family, with whom a rich, stimulating diet acts as injuriously as alcohol on a liver predisposed to interstitial changes.

*Dietic and Zymotic.*—Overfeeding acts primarily as a stimulant to hepatic tissue, and theoretically brings as an after-result cirrhotic changes analogous to those of interstitial nephritis, which is frequently excited by a diet too largely nitrogenous. As a rule, these changes are not as frequently met with in the child as in the adult, but the *modus operandi* is identical, except that in the child the overtaxed liver is apt for a while to relieve itself by critical fluxes, or so-called bilious attacks, but finally chronic hepatic incompetence is established, and true cirrhotic changes begin. Closely allied to these are the cirrhotic changes produced in the liver by the decomposi-

tion-products of *phthisis*. Tubercles frequently are deposited in the liver, impairing its function, but aside from these we meet in phthisis with cirrhotic changes determined, as the writer believes, by the toxic action of the ptomaines generated by the decomposition of disorganized tissues. This is well known to follow scarlatina occasionally,—*e.g.*, Klein reports eight cases of interstitial hepatitis following scarlet fever; and similar lesions are not infrequent in other infectious diseases which have long been known to originate chronic inflammatory changes in the various excretory organs (Botkin).

The action of these zymotic poisons upon the liver is in all probability analogous to that of alcohol, or to that of tea, which if taken to excess, as by tea-tasters and Siberian exiles, not infrequently determines a true cirrhosis of the liver.

*Rickets*.—It seems fair to conclude that any cause which persistently obstructs the normal action of the liver may lead eventually to cirrhotic changes in that organ, which may be induced, some think, even by chronic gastro-intestinal catarrh. This is Dr. Hogben's<sup>1</sup> explanation of that form of hepatic cirrhosis which he believes to be due to rickets. It is certainly not infrequent in rachitic children, and in its general appearance and microscopically resembles ordinary hypertrophic cirrhosis. The changes observed in the bile-duets and canaliculi led Hogben to believe that their lesions originate in a chronic obstruction to the flow of the bile, due in all probability to the chronic gastro-intestinal catarrh so frequently associated with rickets.

Similarly, either from the action of a specific poison or from a general hepatic congestion, we find produced the typical forms of cirrhosis associated with syphilis and malaria which are discussed later under their proper headings.

**Pathology and Pathological Anatomy.**—Engorgement of the hepatic veins from any cause leads eventually, says Eustace Smith, to atrophy of the hepatic cells. These atrophied cells are stained deeply with bile, and at the circumference of the lobule the cells are often filled with oil. Finally a fibroid tissue supplies their place and by its contractions a condition akin to cirrhosis is produced.<sup>2</sup> This is perhaps Carpentier's cirrhosis, rather than Charcot's, which begins as a periplebitis, whose initial lesions are those of chronic inflammations of the branches of the portal vein, resulting in a proliferation of embryonic cells which subsequently are transformed into an excessive amount of fibrous tissue. A more careful study of these changes seems to show good reason for the following convenient divisions.

(a) *Alcoholic Cirrhosis*.—Strauss's experiments in regard to the artificial production of cirrhosis (Society of Biology) prove that alcoholic cirrhosis may be induced in rabbits (dogs were too sensitive) by pouring down the œsophagus one-half ounce of absolute alcohol and methyl alcohol diluted

<sup>1</sup> Birmingham Medical Reporter, August, 1888.

<sup>2</sup> Eustace Smith, p. 722.

with three parts of water. The first effect of this injection in the majority of these animals was to cause them to fall as if paralyzed, and to lie for several hours in coma. If alcohol was given for several months and the rabbits were then killed, the usual lesions of chronic alcoholism were found,—viz., thickening of the gastric mucous membrane, ecchymotic petechiæ, etc. The liver did not present any marked alteration to the naked eye, but the microscope clearly revealed, in the livers of those animals which had been kept intoxicated for three or four months, that the acini were surrounded by a reddish-gray line, and the ultimate perilobular portal spaces were found infiltrated with embryonic cells.

Hares that were subjected to alcoholic intoxication for seven or eight months showed the hepatic lobules completely surrounded by a crown of connective-tissue cells presenting typical forms of annular, perilobular, and monolobular cirrhosis.

(b) *Rachitic Cirrhosis*.—Hogben's observations made on the livers of rachitic children, after taking pains to exclude all cases in which there was a suspicion of tuberculosis, syphilis, or alcoholism, revealed, as a rule, the liver tough, solid, and heavier than would be usually estimated from its appearance. The surface was smooth and of a color varying from that of deep congestion to the red mottling of fatty infiltration. There was in all cases an increase of the fibrous connective tissue, occasionally associated with fatty infiltration of the hepatic cells. The fibrous growth was most marked as interlobular connective tissue, surrounding and isolating the individual lobules. In the immediate neighborhood of the interstitial growth and at the periphery of the lobules there was at times a small cell-infiltration, derived apparently from the interlobular connective tissue, which encroached upon the hepatic cells at the margin of the lobules. Occasionally there was also a very marked thickening of the coats of the bile-ducts, and there seemed also to be a multiplication of the biliary canaliculi.

(c) *Atrophic Cirrhosis*.—A cross-section shows a yellowish-red liver-substance traversed by a fibrous net-work, which net-work holds within it the branches of the portal vein and extends into the interlobular spaces, where it forms meshes of various sizes, enclosing several lobules within them. The later contraction of this fibrous net-work flattens and at last atrophies the liver-cells embraced within its meshes. For the same reason there is diminished circulation in the hepatic portal system, since the lumen of these vessels is diminished by their lessened size. The hepatic venous system proper—intralobular, sublobular, and the hepatic trunks—does not participate in this form of cirrhosis. In other words, in atrophic cirrhosis the hyperplasia of the connective-tissue framework compresses the hepatic cells and presses upon their venous capillaries. This morbid process begins in the finer ramifications of the portal vein, the interstitial inflammation being located chiefly in the cellular tissue surrounding these veins,—i.e., in Kiernan's interlobular spaces. The smaller bile-ducts are but little affected

by these changes, since the blood-supply by which the liver is nourished and the bile is formed is preserved by vessels developed in the neoplasm (Starr). Subsequent contraction of this hyperplastic tissue is the cause of the dense structure and nodulated surface of the liver found in hobnailed liver in the post-mortem examination of these cases. The edges of the liver are thin, while the capsule is thickened.

(d) *Hypertrophic Cirrhosis*.—In the hypertrophic form of cirrhosis the liver is enlarged, sometimes to twice its normal size. Its surface is smooth, its edge thin, and the cross-section is orange or greenish yellow. The fibrous proliferation in these cases begins around the intralobular branches of a bile-duct, enveloping and *isolating separate lobules*. The fibrous growth therefrom follows each ramification of the bile-duct, is more diffused than that met with in the atrophic form of cirrhosis, and is of varying thickness and density. The portal circulation is therefore not necessarily obstructed, while the bile-ducts are not only obstructed but also dilated and show an increase in the thickness of their epithelial lining. Such persons become rapidly and progressively jaundiced and usually die of profound or malignant icterus. This is Charcot's biliary cirrhosis, the name originally indicating that cirrhosis arises from a blocking up of the bile-ducts. Latterly the name has lost in a measure its first meaning, and it is now used to denote increased formation of small bile-ducts from any cause whatever.

**Pathological Complications.**—The most frequent of these is *splenic enlargement*, which may be found in both atropic and hypertrophic cirrhosis, due, as Dujardin-Beaumez suggests, to an effort made to relieve the stasis in the congested portal mesenteric veins.

The *kidneys* may also participate in the general parenchymatous degeneration, and in the profound icterus of the later stages of hypertrophic cirrhosis they contain bilirubin infarcts. The urine in such cases contains not only biliary coloring-matters but the bile-acids as well, since there is frequently an excess of uric acid present in this secretion, due, as Granville thinks, to the primary failure of the liver to furnish the proper amount of bile to co-operate with the pancreatic juice. This produces duodenal indigestion, according to the previously mentioned writer, because the food-elements are only emulsified, and not saponified as they ought to be, and the result is *lithæmia*, which may be associated with hæmoglobinuria or cholæmia.

During the past year considerable attention has been given to the study of the urobilin which appears in the urine in cirrhosis. Some suppose that urobilin is formed from biliary coloring-matters, and that under certain circumstances it is deposited in the tissues and reappears in the urine; others, that it is only an exaggeration of the pigment that gives urine its red tint and varying according to the quantity of urobilin present, which may or may not be associated with biliary pigments. Urobilinuria also occurs in cancer, in lead-poisoning, in alcoholic poisoning, and in rheumatism, gout, pneumonia, angina, and intermittent fever. Hence Hayem considers uro-

biliruria a proof of hepatic incompetency, due to a languid liver manufacturing urobilin instead of normal bile-pigments. Urobilin is then taken up by the urine, and its persistent appearance therein is a matter of considerable importance in prognosis. It should also be remembered that albuminuria is necessarily associated with continued venous stasis of the liver (Hayem).

**Symptomatology.**—(a) *Alcoholic.*—The symptoms arising from the use of alcoholic liquors in the child differ but little from those characterizing their abuse in the adult. Hence we find, as might be expected, disturbances of digestion, gastric catarrh, etc., alternating with periods of comparative health, attended in some cases with an excessive appetite. Marchison reports a case in which the child suffered from the morning vomiting of a confirmed toper and within a month developed ascites.

The quantity of spirits used daily by some of these children is remarkable, as, for instance, the case reported by Wilkes of an eight-year-old girl who drank daily one-half pint of brandy. The literature of the subject is very imperfect, and there is a remarkable absence of the nervous symptoms which are observed in the adult in similar cases, and which might naturally have been looked for in the child, who dies, as a rule, apparently from ascites and cholæmia, rather than from the delirium tremens of the adult.

(b) *Atrophic cirrhosis*, in all its varieties, is characterized in its earlier stages by the usual symptoms of hepatic incompetence,—viz., a metallic or coppery taste in the mouth, an unnatural craving for food, often appearing immediately after eating and varying from slight discomfort to actual gnawing distress allayed only by more food. Or the dyspeptic symptoms may take the form of anorexia and distaste for food, thirst, and marked irritability. There may also be weariness and weakness of the lower limbs, which are unable to perform their usual duties except under protest and subsequent aching, as if they had been forced to do some difficult task. Another and a more unusual symptom is that of a distressing morning sickness, not unlike that of pregnancy, except that the vomited matter is sour or bitter, according to the relative proportion of gastric juice and bile it may happen to contain, together with a copious supply of mucus. Sharp attacks of temporary diarrhœa are apt to supervene, and general impairment of nutrition is apparent, for in atrophic cirrhosis circulation is chiefly interfered with. Hence in this form of cirrhosis the earlier symptoms are those of flatulent indigestion, with its accompanying discomforts. The child is restless at night, and peevish and irritable during the day. Dark circles appear beneath the eyes; the muscles are flabby; the urine may be loaded with urates and give the usual brick-dust deposit, and is often very acid. In other words, we have *uric-acid lithæmia*, or failure of the liver to transform albuminoids into urea. It does not particularly concern us at what stage in the digestive process this failure takes place. It is sufficient for clinical purposes to know that such failure is very frequent

with children, and produces the symptoms given above and long ago described by Murchison under the name of lithæmia.

Other, and no less important, symptoms of hepatic incompetence are those of headache, fever, and chill, often wrongly ascribed to malaria. Malaria, if it exists in these cases, is a malaria generated within the child's organism, and is in all probability due to leucomaine or kindred intoxication. The leucomaines are in general virulent poisons, producing death when hypodermically injected into the lower animals. Gauthier's experiments prove that auto-infection with these leucomaines is not only possible but inevitable whenever they accumulate in the system to such an extent that their destruction is not accomplished by the usual emunctories. Chief among these agents his experiments place the liver. The failure of this to perform its duty, either in whole or in part, produces much of the continued malaise met with in children, wrongly named and falsely treated as "dumb ague."

These prodromal symptoms are usually overlooked, or misinterpreted, until ascites attracts the attention of the parent, or of the physician, to whom such children are not brought, as a rule, until the enlarged abdominal veins or dropsical effusions clearly point to the source of the child's continued ill health.

In atrophic cirrhosis there is often no real jaundice, though the skin feels rough and dry and assumes an earthen tint. The ascites (for which see page 511) is variable in amount. The feet and limbs may also become œdematous from the pressure of the fluid contained in the abdomen.

The later stages of fatal cases of hepatic cirrhosis are marked by symptoms due either to ascites or to progressive incompetence of the liver, such as increasing weakness, emaciation, and leucomaine-poisoning. The tongue is rough and furred, and fever, at first and for a long time absent in these cases, at length appears, and is of a clearly-marked remittent type and often mistaken for fatal intermittent. More frequently death results from progressive starvation, the dyspeptic symptoms becoming more aggravated as the disease advances. Vomiting is now troublesome, and there is a constant sense of weight in the stomach. Abdominal pains are frequent. The tongue is constantly furred and the appetite completely lost. Thirst is abnormal. The child wastes, and its complexion grows dingier than ever. Hemorrhoids and consequent pruritus are not infrequent. The child grows weaker, until at last it dies, either from general dropsy (spanæmia) and diarrhœa, or from exhaustion without the appearance of any new symptoms. In other cases death may result from internal hemorrhage, pleurisy, or pneumonia.

The initial symptoms of the *hypertrophic variety of cirrhosis* are about the same as those met with in the atrophic form,—viz., gastric dyspepsia, pallor, and wasting. Later other symptoms develop, due to interference with the proper circulation of the bile; hence, while we find jaundice rarely present in atrophic cirrhosis, it is a well-marked and early symptom in the hypertrophic form. The skin, conjunctivæ, and urine are those character-

istic of obstructive icterus, and the passages from the bowels present the usual clayey appearance of catarrhal jaundice. Pain over the liver is tolerably constant. The bowels are exceedingly variable, now constipated and again relaxed. With the progress of the disease the icterus deepens, and the liver may for a period rapidly enlarge, with increase of pain in the side, fever, and fretfulness. Again, there may be temporary amelioration, but the course of the disease is steadily towards death, although at times the general condition of the child is perplexing,—on some days apparently nearly well, lively and playful, and on others too cross and irritable to be endured, but easily tiring in either condition.

The later stages of hypertrophic cirrhosis are frequently attended with hemorrhage from the gastro-intestinal mucous membrane, the blood being vomited, or passed with the stools, which in consequence are usually black and tarry, though occasionally bright red if the hemorrhage is profuse. The latter condition could hardly escape the attention of the physician, but small quantities of changed blood in the stools might not be noticed unless they are placed in water, which becomes red if blood is present, but only greenish or brown from altered bile-pigments, affording an easy method of diagnosis in doubtful cases.

Bleeding may also take place from the gums and nose, or petechiæ may show here and there upon the body. The case may even terminate fatally from exhaustion consequent upon hemorrhage. According to Cyr, this is frequent in the later stages of both forms of cirrhosis (one in thirty-eight of atrophic and one in forty of hypertrophic cases), but, as a rule, a case of hypertrophic cirrhosis dies with the symptoms of malignant jaundice, or cholæmia. This is characterized by curious alternations in the frequency of the pulse, which is that of septic poisoning, as proved by the dry brown tongue, sordes on the teeth, etc. The child is heavy and drowsy, refuses food, and wishes only to be left undisturbed. Ecchymotic spots, or bleeding from the gums, may complicate the case, or with these there may be hæmatemesis. Drowsiness passes into stupor, the child lying insensible, grinding its teeth constantly, until death occurs, either by convulsions or by deepening unconsciousness, all without fever, as a rule.

*Physical examination* in the earlier stages of atrophic cirrhosis shows slight enlargement of the liver and spleen. Later the liver shrinks and cannot be easily felt, but the spleen continues to increase in size. In hypertrophic cirrhosis the enlargement of the liver can be more easily detected.

According to Eustace Smith, both forms of cirrhosis may be conjoined in the same child, for their lesions affect different structures in the liver. Such cases would present a combination of symptoms very puzzling to the diagnostician unacquainted with this fact, for in such children we might expect to find enlargement of the liver, jaundice, and hemorrhage, associated with ascites, dilatation of the abdominal veins, and splenic enlargement.

Splenic enlargement is generally found in both the atrophic and the hypertrophic forms of cirrhosis, in the former of which it may be difficult



of detection if complicated with any considerable amount of ascites. Even then it can usually be detected by resorting to the manoeuvre of putting the child upon its hands and knees, which brings the enlarged organ well forward by its own weight and places it easily within reach of the physician's fingers.

*Intercurrent Diseases.*—The more frequent of these are pleurisy, pneumonia, peritonitis, and ascites, elsewhere described.

Interstitial changes in the lungs and kidneys similar to those in the liver are sometimes present, but, as a rule, the kidneys maintain their functions well to the last.

*Differentiation.*—The differential diagnosis of the earlier stages of any form of cirrhosis is a task no easier in the child than in the adult. We may, however, fear its onset whenever there is an inexplicable persistence of hepatic incompetence. This does not necessitate clay-colored stools, for hepatic incompetence may exist with normal-colored fæces, and, *per contra*, the liver may be efficiently performing its work, and yet intestinal catarrh, or a milk diet, may produce the light stools which are thought to require a mercurial powder. Again, hepatic incompetence does not require that the liver should be enlarged, though a chronically congested liver becomes thereby eventually more or less incompetent. On the other hand, it is well to remember Eustace Smith's hint, that "the liver is apt to vary in size from natural causes in young children, some having exceptionally short chests and causing the liver without enlargement to be displaced a finger's breadth or so below the ribs. Again, empyema, emphysema, or pericardial effusion may do the same; hence in rickety children both liver and spleen may be felt below their normal position, or, *vice versa*, an enlarged liver may be pushed upward by fluid in the abdomen, or drawn upward by the contraction of the lung."

The same author well says that "many symptoms attributed to a torpid liver and treated with gray powder are really due to a disordered state of the stomach arising from an improper dietary." Nevertheless, while gastric catarrh may be mistaken for hepatic incompetence, the error is more frequent in the other direction, for sick headache, anorexia, and gastric catarrh and diarrhoea more often originate from leucomaine-poisoning than *vice versa*. In its later stages the diagnosis of atrophic cirrhosis ought to be no more difficult in the child than in the adult, for ascites, an enlarged spleen, and dry, earthy skin, without fever, render a diagnosis of atrophic cirrhosis reasonably certain, especially if this condition has been preceded by failing health for some time previous. If to these is added hemorrhage from the stomach or bowels, with a normal temperature, it will strongly confirm our diagnosis. Febrile complications may obscure the diagnosis, but it should be remembered that such febrile exacerbations are common to all chronic diseases of children, and in doubtful cases the diagnosis should be reserved until the febrile attack subsides.

*Hypertrophic cirrhosis* may be recognized by its progressive jaundice,

enlarged and painful liver, wasting, and persistent dyspepsia. Ascites, enlarged abdominal veins, and hemorrhoids are generally absent. Such cases are apt to terminate with the symptoms of malignant jaundice, which in many cases may be readily mistaken for those of acute yellow atrophy, especially if the liver is but slightly enlarged.

Amyloid degeneration may be excluded if its usual causes—phthisis, chronic suppuration, etc.—have been absent from the history of the case.

Urobilinuria (see page 493) may be of value as indicating fatty degeneration of the liver-cells. Urobilin is easily demonstrated, as its detection requires only the addition of the suspected urine to colorless nitric acid. The urine is added as in the nitric-acid test for albumen, and becomes deep brown, growing lighter as it recedes from the acid, if urobilin is present.

**Prognosis.**—In general the prognosis is bad. Marked wasting and an earthy tint of the skin are of unfavorable import, but even a considerable degree of ascites is not necessarily fatal if otherwise the general health is not seriously impaired.

In alcoholic cirrhosis, if detected early, the prognosis is greatly improved by the early and complete abandonment of all forms of alcohol. A gloomy prognosis must be given in all cases where there is progressive jaundice, especially if accompanied with febrile symptoms, drowsiness, or nervous manifestations. Urobilinuria is not a favorable symptom.

Recent discussions of cirrhosis in the French medical journals give better hope of recovery than was formerly believed possible. Troisier reports apparent cures, and believes that there is a stage in cirrhosis—especially alcoholic—in which the lesions have not yet proceeded to actual destruction of the liver-cells, and hence are curable. His results and those attained by others in the treatment of malarial cirrhosis seem to render this view probable, although Birch-Hirschfeld declares that the prognosis of hepatic cirrhosis is “entirely unfavorable, such cases proceeding more rapidly to a fatal termination with children than with the adult.” Cyr regards it as the most dangerous form of hepatic disease.

Hemorrhage in either variety of cirrhosis is, as a rule, good proof of an early fatal termination. The same holds true in regard to the appearance of pernicious icterus. Delirium and coma are most discouraging complications and portend an early demise.

In the main, it may therefore be said that treatment is discouraging but not hopeless, and is the more favorable the earlier it can be commenced.

**Treatment.**—*Prophylactic.*—First and foremost, wherever cirrhosis is even suspected, must be placed the immediate abandonment of alcohol, if it has been used in any form, with prompt attention to the child's digestion. This may be aided by alkalis or tonics and by keeping the bowels open with a mild aperient. Many cases need also quinine and iron unless the tongue is furred and the child feverish.

Hepatic incompetence is an ailment never to be disregarded in children. It may never proceed to actual cirrhosis, but the possibility of such termi-

nation should always be borne in mind; the more so since the diagnosis of cirrhosis in its earlier stages, except in the alcoholic and malarial varieties, is a very difficult task. Attention to the matter of diet is of prime importance in these doubtful cases, for it should be remembered that excess of albuminous and stimulating foods produces engorgement of the hepatic veins, which in turn leads to engorgement of the liver-cells in their immediate neighborhood. This engorgement, according to Eustace Smith, leads eventually to a replacement of the liver-cells by fibroid tissue, which by its contraction produces a condition of affairs analogous to cirrhosis, if not true interstitial hepatitis. Hence the very great importance of such diet as shall not overtax the liver in the beginning of such cases. Starchy foods, bread-and-milk, fruits, broths, and broiled fish are articles which require the least assistance from the liver for their digestion, and are clearly indicated in the early stages of incompetence, which may often be thus relieved without the use of drugs. When, as frequently happens in these cases, there is a copious deposit of urates or uric acid in the urine, compound spirit of lavender or small doses of salicylic acid will be found helpful. The latter, combined with pepsin (one to two), will often be found especially useful where there is deficient secretion of bile and consequent intestinal fermentation; although pepsin, as a rule, does not give as good results in this class of cases as in other forms of dyspepsia, possibly because in intestinal dyspepsia we have decomposition-products formed from the malassimilation of peptones and parapeptones, and the use of pepsin simply increases these and their resulting toxic compounds.

Sick headache and migraine may be relieved by the use of a pill of oxgall and oil of wintergreen (gr. i to gtt. i), aided by antipyrin during the intervals of pain. The latter remedy is also valuable in many of the so-called malarial (toxæmic) fevers of childhood, where we have regular intermissions and exacerbations, the fever in these cases often running for a few hours as high as in the initial stages of pneumonia or scarlet fever. These cases may be treated almost indefinitely by quinine and the other antiperiodics without relief, but are promptly cut short by a brisk mercurial purge and antipyrin in sufficient doses to keep the temperature down to normal, the drug in these and similar cases acting probably, in some way not yet explained, by assisting in the elimination of the leucomaines.

Where increased secretion of bile is clearly indicated, podophyllin, corrosive sublimate, or benzoate of ammonium or sodium will act most satisfactorily,—calomel assisting in the expulsion of the bile already formed, rather than increasing its amount. Complicating gastric catarrh and intestinal fermentation are relieved by the free exhibition of alkalis and laxatives, such as phosphate of sodium, senna, or calomel, preference being given to calomel, on account of its antifermentative properties.

*Specific medication.*—Troisier<sup>1</sup> reports cures of hypertrophic cirrhosis

---

<sup>1</sup> Annual of the Universal Medical Sciences, 1888. p. 339.

(in the adult) by means of full doses of potassium iodide with strychnine. Schreph claims similar results with an absolute milk diet and small doses of calomel, after Carlsbad salts and the other usual remedies had failed. Tincture of the chloride of iron with strychnine is recommended by Dr. W. H. Thompson. Others speak highly of the use of the iodides and corrosive sublimate. Cyr often employs cold compresses, with leeches about the anus in acute cases. Internally he administers three or four grains of calomel, to be followed in the morning by Glauber or other laxative salts. Milk and Vichy, or a weak solution of ammonium chloride in water (gr. lxxv to Oi), should be taken freely as a drink, and tepid douching of the liver while the patient reclines is grateful and advantageous, says the same author. Beale highly recommends a nitro-hydrochloric-acid (one to eight) pack over the liver, and others speak enthusiastically of faradization, in twenty-minute séances, especially in engorgement with jaundice. One pole of the battery should be placed over the intestines opposite the middle dorsal region, while the other pole should be passed over the right and left lobes of the liver, with occasional pauses directly over the gall-bladder. Cyr advises counter-irritation even to the extent of actual cauterization in chronic cases. Ammonium chloride, according to Dr. Stewart, when taken for engorgement of the liver, will produce in a few minutes to a half-hour "a sensation as of a shock, or as if cold water were trickling down the side, or even as of pulling, clawing, or gnawing. These are favorable signs, for they do not occur unless hepatic disease be present." The only contra-indication to the use of ammonium chloride is high fever with a hot dry skin, when ammonium acetate may be profitably substituted for the muriate. During treatment Dr. Stewart confines his patients strictly to bed and limits them to small quantities of milk and farinaceous foods, with barley-water as a drink. Diarrhœa does not contra-indicate the use of ammonium chloride, for looseness of the bowels may arise from congestion of the liver, which is most promptly relieved by this salt.

Dujardin-Beaumez's latest advice is to "place at the head of your treatment milk diet, which of itself is capable of bringing about an amelioration equivalent to a cure." Cases reported at several recent sessions of the French medical societies seem to show that such recoveries are by no means so rare as one might suppose. A favorite prescription of Dujardin-Beaumez's is the following :

R Pure hippuric acid, 25 grms. ;  
 Milk of lime (neutralized), q. s. ;  
 Syrup, 500 c.c. or grammes ;  
 Essence of anise (to flavor), q. s.

Mix.

Sig.—Four to six teaspoonfuls a day."

Among other formulæ which may be found useful in the treatment of hepatic cirrhosis and its complications are—

GASTRIC TONIC.<sup>1</sup>

Sodii bicarb., ℥ii;  
 Tinet. nuc. vom., ℥xvi;  
 Inf. calumbæ, ℥ii.

Teaspoonful before meals.

IRON MIXTURE.<sup>2</sup>

Tinet. ferri chlor., ℥x;  
 Acid. acet., ℥x;  
 Liq. ammon. acet., ℥ss;  
 Aquam ad ℥ss.  
 Pro dos. t. i. d.

Eustace Smith also advises the use of the exsiccated sulphate of iron in full doses (gr. vii in glycerin). Of mineral waters the most highly esteemed are the Carlsbad, Harrogate, and Vichy.

The action of the skin should be assisted by the use of warm baths daily, and the child properly protected from chilling by woollen underwear.

The treatment of lithic symptoms is, on the whole, satisfactory, for we agree with A. Haig that uric-acid excretion is largely under the control of the physician by means of drugs and foods, and that when uric acid is diminished relatively to urica such diminution is due to the retention of the uric acid in the liver and spleen and possibly in other organs. Increased excretion means the washing out of this retained acid: hence uric-acid migraine can be produced by increasing the acidity of the urine. Animal food increases the absolute amount of uric acid. Where there is retention, potassium iodide (gr. v) has little or no effect; in large doses it acts as an alkali. Phosphate of sodium is a good solvent of uric acid, and greatly increases excretion, because of its union with uric acid in more soluble forms. Salicylates excrete uric acid independently of acidity; colchicum lowers acidity and thus assists excretion.

Kellogg, of Battle Creek, Michigan, highly recommends rectal insufflation of oxygen in these cases. Theoretically it ought to be of great value. Empirically the writer has found the compound spirit of lavender a valuable adjuvant to other drugs for the removal of uric-acid sediments.

Hemorrhage, when alarming, may usually be checked by gallic acid, dilute sulphuric acid, or other astringents.

## MALARIAL CIRRHOSIS.

**Definition.**—According to Lancereaux, malarial cirrhosis is a characteristic form of hepatic disease produced by malarial intoxication.

**History.**—The affection was first described by Lancereaux in lectures recently delivered in Paris, although the effects of malarial poison upon the liver had frequently been referred to by other authors, especially by West, who in his earlier writings calls attention to the fact that children under the influence of malaria often develop ascites with dryness of the skin and

<sup>1</sup> Eustace Smith.

<sup>2</sup> Ibid.

general disturbance of nutrition. Similar cases have long been known in the rice-fields of Pavia and among the poor whites of the South and others residing in malarious districts.

**Etiology.**—The exact etiology of malarial cirrhosis can as yet only be surmised. If the existence of Laveran's bacillus malarie be proved, and its action upon the blood-corpuseles is that described by Sternberg, it is more than probable that the products of such destruction are chemical compounds analogous to the leucomaine poisons in their action upon the liver.

**Pathology.**—The chief morbid changes noted by Lancereaux are great enlargement of the liver and increase in its weight, which is sometimes doubled without causing the organ to lose its normal shape. Its surface is smooth and without prominences, but the liver-tissue is increased in density to a degree a little less than that of cirrhosis produced by alcohol. Unlike this, it does not grate beneath the knife, nor has it the elasticity of alcoholic cirrhosis. A cross-section shows variable pigmentation, but the granulations do not project above the cut surface, like the larger papillæ of ordinary cirrhosis. A proliferation of connective tissue does not accompany the venous radicles of the portal system, nor does the perihepatic net-work of vessels show any evidence of endophlebitis, which, according to Lancereaux, explains the absence of dropsy due to portal obstruction, for many capillaries traverse the new connective tissue, and thus circulation is everywhere preserved.

The consistence of the connective tissue, however, rather than its arrangement, is especially distinctive of this form of cirrhosis, in which we find this tissue in its embryonic state, unlike the firm, hard, unyielding connective tissue of ordinary cirrhosis. "In malarial cirrhosis the proliferation presses only on the borders of the lobules, which thereby become fringed and irregular, but the lobule is not invaded, nor is its central vein implicated. The biliary canaliculi are extensively distended by the new growth, which leads to their greater prominence and to the chronic jaundice which is a very marked symptom. The larger bile-ducts and the common duct always remain free. The liver-cells on the surface of the lobule are compressed and elongated, and their protoplasm is diminished. In the centre of the lobules the liver-cells preserve their normal form and are filled with bile-pigments and fat-granules merely" (W. H. Welch).

**Symptomatology.**—The symptoms of malarial cirrhosis differ little, if any, from those of atrophic cirrhosis, beginning, like it, with dyspeptic symptoms, vomiting, and transient diarrhœa. There is often troublesome pruritus, and the skin is rough and dry. Epistaxis is prone to occur, although bleeding from the gums is more frequent. Occasionally heart-murmurs are present at the right border of the sternum, due to tricuspid regurgitation (Potain), but the respiratory sounds are unaffected. One of the rarer symptoms is hemeralopia, intermittent or variable, attributable to pigmentary deposits in the retina, first observed by Scarpa among the

peasants working in the rice-fields of Pavia. This symptom occurs only in chronic cases. Delirium and fever attend the close of fatal cases of malarial cirrhosis, the patient usually dying in coma.

**Differentiation.**—Lancereaux clinically differentiates this form of cirrhosis by (1) its history of chronic malarial intoxication; (2) the hypertrophy of both the liver and the spleen; (3) the persistence of jaundice, lasting at times for years; (4) the color of the skin, being of a dark-brown tint rather than of the greenish-yellow hue characteristic of jaundice due to impaction. It can furthermore be distinguished from alcoholic cirrhosis (atrophic) by the great enlargement of the liver, the implication of the spleen, and the absence of dropsy in malarial cirrhosis. It may be differentiated from alcoholic fatty hypertrophy by the edges of the liver being found sharply defined in malarial cirrhosis, while fatty hypertrophy causes them to become rounded and roughened. Carcinoma with jaundice is not easily diagnosed from malarial cirrhosis except by the previous history of the case, and by the development of nodosities sooner or later in the cancerous cases.

**Prognosis.**—The prognosis is generally favorable to life, and hopeful for entire recovery, if the patient can be early removed from the malarious districts. The results obtained by Lancereaux in children were very encouraging, and the same is true of West's cases, which under treatment with cinchona recovered so rapidly that Birch-Hirschfeld is inclined to doubt their having been cases of true cirrhosis.

**Treatment.**—The treatment of malarial cirrhosis in its earlier stages is about the same as that of the usual hepatic congestion of intermittent fever, —viz., with quinine, wet or acid packs, ammonium chloride, etc. In the later stages hydropathy may be useful, and potassium iodide should be substituted for quinine and continued for weeks and months, with a rigid milk diet (Lancereaux). The author has in some of these cases obtained excellent results from syrup of iodide of iron and Fowler's solution, conjoined with the free use of buttermilk or skim milk.

#### SYPHILITIC CIRRHOSIS.

**Synonymes.**—Congenital cirrhosis; Hepatitis interstitialis syphilitica, Peripylephlebitis syphilitica, Diffuse and circumscribed syphilomata of the liver; German, Gummata des Lebers.

**Definition.**—An interstitial hepatitis due to syphilitic poisoning, acquired or congenital.

**History and Occurrence.**—Syphilitic hepatitis is one of the more frequent lesions of the liver in early infancy, though more rarely observed in older children; but it should also be remembered that, with the exception of catarrhal icterus, diseases of the liver are comparatively rare in children. Of the forty thousand sick children examined by Steiner, there were only four hundred and twenty-five cases of diseases of the liver, syphilitic hepatitis standing sixth in his list, and being noted as uncommon.

**Etiology.**—Hepatic syphilis belongs peculiarly to early infancy. The

largest number of cases reported were found in the very earliest period of life, frequently prenatal, but at any time during the life of the child syphilis of the liver may appear.

It is a frequent cause of infant mortality, for of four hundred and ten autopsies made by Birch-Hirschfeld upon infants one hundred and twenty-four gave proof of syphilization of the internal organs, especially the liver. Specific infection, of course, lies at its foundation, and in by far the larger number of cases this is inherited from the parents. More rarely it originates from the nurse, and later in childhood there are beyond doubt well-marked cases of acquired syphilis, like those of the adult, although it is still a question in dispute whether these liver-manifestations occurring late in childhood may not be due to syphilis inherited from the parents. Dittrich gives cases of hepatitis syphilitica in children of eleven, fifteen, and eighteen years, which apparently confirm the possibility of the appearance, even at those ages, of these late syphilitic manifestations.

**Pathology.**—A typical syphilitic liver is dense, elastic, irregular in outline, nodulated, with increased size and density, and giving an impression of resistance above normal when cut. The color, according to Gubler, is like that of flint, while Trousseau compares it to that of sole-leather. Birch-Hirschfeld says it has all possible tints from yellowish white to dark brown.

The structure of the acini is completely obliterated, but it should be remembered that in the new-born these are normally indistinct. A closer examination with a glass often shows in the cut surface innumerable fine gray or grayish-white points and lines which bespeak a proliferation of the interlobular connective tissue. It is also to be noted that the connective tissue in the immediate neighborhood of the branches of the portal vein is thickened. The capsule of the liver shows at times, to a more or less marked degree, thickening, and may be adherent to the peritoneum or the abdominal walls, while the peritoneum itself shows proof of well-marked thickening. The gall-bladder often contains only slimy yellow masses, or, in other instances, a small quantity of brownish-green bile. If the syphilitic hepatitis be localized instead of diffuse, there will be found isolated spots of sclerosis scattered here and there through the liver; or true syphilitic gummata may be discovered as sharply-defined nodules from the size of a pea to that of a walnut, which differ in no essential particular from those met with in the other organs of syphilitic children, in whom they appear either as an acute swelling without well-marked gross alteration, except a diffuse growth of the connective tissue, or there may be diffused miliary gummata, or peripylephlebitis syphilitica,—*i.e.*, a syphilitic inflammation of the hepatic septa. According to Starr, syphilitic proliferation differs from true cirrhosis of the liver in that the former "invades the connective tissue between the hepatic islands and that in their interior as well," while cirrhosis proper affects only the connective tissue between the lobules. The bile-duets may also be thickened and occluded with epithelial



cells, especially if the case be complicated with jaundice. In these cases the volume of the liver is little if at all increased, and an incision fails to give the sense of resistance met with in general syphilitic hepatitis.

The miliary gummata previously alluded to consist of a dissemination through the liver of a large number of millet-seed dots, or gummata, which not infrequently coalesce to form knots. This is apparently a characteristic syphilitic lesion of the earliest years of childhood, and may appear either in a liver which is in the main normal or as a generally diffused miliary gumma (Birch-Hirschfeld).

Contraction of the syphilitic liver follows as a result of the retraction of these syphilitic masses of hypertrophied connective tissue. At the beginning the formation of gummata in the liver is attended with an increase in its size; this is well marked in young children; later the tissue shrinks gradually, until at last it becomes less than its original bulk.

**Complications.**—Perihepatitis and increase of the connective tissue of Glisson's capsule, according to Steiner, are the most frequent complications in syphilitic hepatitis. The usual dermal and visceral lesions of hereditary syphilis may, of course, be met with in these cases. Splenic enlargement is almost invariable.

**Symptomatology.**—There are, says Birch-Hirschfeld, no strictly characteristic symptoms of syphilitic hepatitis which are diagnostic of this complication, for, as in the adult, the morbid process may develop without any well-marked symptoms, unless a perihepatitis complicates and produces pain and tenderness. Icterus is not usually a prominent symptom, especially in the new-born child, in whom syphilitic symptoms are few and ill defined. The liver itself is irregularly enlarged and harder than normal, and may, if this enlargement is great, give rise to jaundice, as happens in all forms of hypertrophic cirrhosis from mechanical compression of the bile-ducts. Ascites occurs later, associated with marasmus and a subnormal temperature. Ecchymoses and ordinary skin-lesions of hereditary syphilis may, of course, appear. Such children, aside from these lesions, may often be suspected from their fretfulness, uneasiness, and whining without shedding of tears. They rub their legs against the abdomen until it becomes swollen and chafed. Vomiting and diarrhoea or constipation are frequent, and the pulse, as a rule, is small and weak. In fatal cases the eyes become sunken and surrounded with dark circles, the extremities grow cold, and the child dies of exhaustion.

**Differential Diagnosis.**—The diagnosis is differentiated mainly by the presence of syphilitic lesions other than hepatic. These being established, and hepatic incompetence or ascites existing at the same time, a diagnosis of syphilitic hepatitis can fairly be made. A mild degree of syphilitic hepatitis is, however, not easily diagnosed (Steiner), as it presents no well-marked proof of its existence either by physical examination or from the study of the child's symptoms, which are inconspicuous and not diagnostic. *Per contra*, hepatic disturbance at a very tender age, especially if accompa-

nied by enlargement of the liver and by ascites or jaundice, should always be considered a sufficiently suspicious circumstance to direct the mind of the attending physician towards the possibility of syphilitic disease, even in the best of families.

If a perihepatitis develops, as is frequent with older children, there will be tenderness on pressure in the region of the liver, and if adhesion has taken place between the capsule of the liver and the abdominal walls the respiratory movement of the thorax will be hindered thereby; but of all the symptoms here detailed the only one which is absolutely constant is the irregular enlargement of the liver. This is often great, and is recognizable as a perceptible swelling of the right hypochondrium. The lower border of the liver may extend to the navel or beyond, and may appear irregularly nodulated or more rarely symmetrically increased in size, yet it is not so much the changes apparent in the liver as their location which enables us to make a reasonable diagnosis of syphilitic hepatitis, whose lesions occur chiefly as neoplasms about the larger bile-ducts and the roots of the larger vessels of the liver (Birch-Hirschfeld).

**Prognosis.**—Steiner and the majority of foreign writers in general, except Goodhart, incline to a gloomy prognosis as regards the cure of syphilitic hepatitis; and yet permanent cures are by no means infrequent. The writer's experience is that of Goodhart, who states that the majority of such cases, except in the very youngest children, are remarkably amenable to mercurial treatment. Profound cachexia, pernicious jaundice, ascites, and hemorrhage are unfavorable symptoms, and are almost invariably precursors of death.

Icterus depending upon congenital syphilis is usually grave, but not invariably so, for Jacobi reports several such cases which recovered.

**Treatment.**—Mercurials are of the greatest value in these cases, combined with the internal use of tonics, cod-liver oil, etc., unless contra-indicated by diarrhœa. Nutrition must be especially looked after, as early syphilis produces general depression of the vital forces: hence the imperative necessity for tonics and a full supply of good and easily-digested food. Of mercurials, preference is usually given to the mild chloride, one-twentieth to one-eighth of a grain of which may be administered in sugar of milk to nurslings twice or three times a day, until contra-indicated by looseness of the bowels; then mercurial inunctions (gr. x-xx well rubbed into the skin daily, or applied upon a flannel binder) will be found efficient, though uncleanly. Later the syrup of the iodide of iron (gr. v-xx) is excellent. Starr recommends iodide of potassium with ammonium chloride in J. Lewis Smith's mixture:

R Potass. iodidi, gr. xxiv;  
 Ammon. chloridi, gr. xxxvi;  
 Syr. sarsap. comp., ℥ss;  
 Aquæ, ℥iii.

S.—Teaspoonful three times a day.

or the following :

R Hydrarg. bichlor., gr. ss ;  
 Potass. iodidi,  
 Ferri et ammon. citrat., āā ʒi ;  
 Syrupi, ʒvi.

S.—To a child from three to five years old.

Splenic enlargement yields more slowly to treatment than do hepatic complications in syphilis of children. External applications, as ammonium-chloride lotions or dilute compound tincture of iodine ointment (one to seven, Starr), will hasten a cure.

J. Lewis Smith prefers minute doses of the bichloride with iodide in the prescription previously given. Otis prefers blue mass long continued. R. W. Taylor prefers the bichloride in compound syrup of sarsaparilla, as do also G. H. Fox and W. H. Draper. Jacobi advises that the mercury should be given for a long time, by the administration of a twentieth or a twelfth of a grain of calomel three times a day ; or by careful inunction of a scruple of blue ointment daily ; or by the subcutaneous injection of one-thirtieth of a grain of corrosive sublimate in a one-fifth of one per cent. solution of distilled water daily. In the beginning of the treatment two of these medications may be combined, or one of them may be accompanied by the internal administration of from three to five grains of iodide of potassium. The internal administration of the bichloride of mercury is also well tolerated ; one-hundredth of a grain may be given in a teaspoonful of water, or food, every two or four hours, and continued many weeks, for a thorough and energetic antisyphilitic treatment is the only safeguard in this disease. And yet treatment often fails, because the syphilitic lesions are not confined to the liver, but extend to the connective tissue of other organs as well.

#### ACUTE YELLOW ATROPHY OF THE LIVER.

**Synonymes.**—Typhoid icterus, Hemorrhagic icterus, Malignant jaundice, General parenchymatous hepatitis (Bartholow) ; French, Atrophie aiguë du foie, Ictère grave, Hépatite maligne.

**Definition.**—An acute, degenerative inflammation of the liver, resulting in arrest of its functions and in death from toxæmia. Steiner would still further limit it to those cases in which an abundance of both leucin and tyrosin may be found in the urine.

**History and Cause.**—So far as the writer is informed, the first account of the occurrence of this rare disease in children is that given by Dr. Loeschner in 1859 in the *Allgemeine Medicinische Central Zeitung*, No. 68. Bouchut speaks of cases which had come under his observation, in some of which recovery took place, but there is no mention of acute yellow atrophy in children by many of the leading writers on pediatrics.

Among adults this disease is more frequently met with in females than in males, but yellow atrophy is so rarely observed in children that it may practically be excluded from their usual diseases.

Dr. H. Greeve, however, reports a recent case, in the *Medical Press and Circular*, April 30, 1888, of a boy aged twenty months who had suffered from jaundice when fifteen months old. Two months later he had another attack, and died the nineteenth day thereafter, with a temperature of 108° F.

**Etiology.**—Twenty years ago the investigations of Oscar Wyss (1868) proved that catarrhal jaundice might be due to a catarrh of the bile-ducts, chiefly in their proximal extremities, the obstruction occurring near their origin. This is fully in accord with Chauffard's theory that jaundice is often due to an accumulation of irritant substances in the liver, which beget an irritation of the hepatic ducts, beginning at their origin. These irritant substances may be and often are the leucomaines and ptomaines, whose effects upon the liver have been carefully studied by Gauthier, Schiff, and Lauterbach. The accumulation of these substances in the blood, together with its disintegration, is, to the mind of the writer, a more probable cause than the large number of others which have been offered as the efficient ones in the production of acute yellow atrophy, among which may be mentioned excess of bile, stasis of bile, cholesteræmia, with anger and violent passions, etc., as predisposing factors. As yet the exact etiology of this disease is not fully understood, but it seems to the writer that Budd and Bartholow are not far from the truth in their suggestion that its cause lies in a blood-poison, of as yet unknown nature, which acts specifically upon the liver-cells and destroys their further action. This hypothesis is well borne out by the fact that phosphorus, antimony, or arsenic when introduced into the system in toxic doses may produce symptoms clinically so nearly like those of acute yellow atrophy that they cannot be differentiated from it without the previous history of the case. According to Rendu, even subacute alcoholism under certain circumstances may do the same. In these cases we know that a specific poison circulating in the blood produces these changes in the liver and resulting toxæmia. By analogy it is fair to conclude that some other poisonous substance produces the closely resembling symptoms and pathological changes of idiopathic yellow atrophy. The writer strongly suspects that this poison, or these poisons, will be found closely related to the leucomaines more fully discussed under the head of atrophic cirrhosis, the jaundice in all probability being directly derived from the decomposition of the red corpuscles,—*i.e.*, hæmatogenous.

**Pathology and Pathological Anatomy.**—Bartholow gives the pathology of this disease as that of an acute, diffuse, parenchymatous hepatitis. The liver is considerably atrophied, and flattens by its own weight, has a uniform yellow color, and is readily friable. Its peritoneal surface is roughened and wrinkled. Microscopically it shows a primary stage of hyperæmia, congested loci persisting even after the rest of the organ becomes anæmic. A grayish-yellow substance is deposited between the lobules and increases the interlobular spaces. Albuminous and fatty matter mixed with pigments is deposited in the cells, and where these have become disinte-

grated there is found fatty brown granular matter. The finer branches of the hepatic artery and portal vein in this way become obstructed. The blood contains considerable leucin and urea. The spleen is usually, though not invariably, increased in size. The endothelium of the lobules of the kidneys is deeply stained with bile and infiltrated with granular matter undergoing fatty degeneration, and the muscular tissue of the heart undergoes similar changes. The urine at first is normal in quantity and of the usual specific gravity, later the urea and the phosphate of lime are diminished and replaced by leucin and tyrosin. Ecchymoses and petechiæ are often found upon the skin.

**Symptomatology.**—In the adult acute atrophy begins insidiously, often like a simple gastro-duodenal catarrh, with epigastric tenderness and slight jaundice. The pulse and temperature at first vary but little from normal, but in from a few hours to a fortnight the temperature rises, insomnia and headache appear, and toxæmia begins, with cerebral symptoms. The pulse is now very rapid (140), but with great variations, often falling to 70 or below, and thus fluctuating several times in a day. There is an evening exacerbation (104° F.) and a well-marked morning remission (102°). Jaundice increases. Sometimes there are brownish patches and the breath is fetid, the tongue dry and brown, and the teeth covered with sordes. Nausea and vomiting are troublesome, and pain is sharp upon pressure over the liver, which is distinctly smaller. Tarry passages take place from the bowels, and a coffee-ground vomit may occur, due to internal hemorrhage.

In other cases the children have been attacked with high fever at the beginning, with hepatic pain, enlargement of the liver, well-marked icterus, considerable prostration, some epistaxis, purpura, or hæmatemesis, and melæna (Bouchut).

With young children (from two to four years old), says Loeschner, the disease may easily be mistaken for meningitis, from the close resemblance of their symptoms; with children from seven to twelve its course is more like that of typhoid fever (see Differentiation), especially in its final stage of great nervous irritability and restlessness, followed by noisy delirium soon passing into a low muttering form and terminating in death from coma, or convulsions.

**Differentiation.**—The differentiation of acute atrophy is not easy, both because of its complications and because as yet there is no definite agreement among writers as to exactly what constitutes acute atrophy. The physical signs of a shrunken liver, fever, headache, and insomnia, with the occurrence of leucin and tyrosin in the urine,—if these be considered diagnostic,—ought to be sufficient to establish a diagnosis; but the disease is a rare one, and undoubtedly is frequently overlooked in adults, and perhaps also in children. In all suspicious cases examinations should be made for leucin and tyrosin. These, when present in urine, may be easily recognized by evaporating it to a small bulk and allowing the salts to crystallize spon-

taneously, when leucin may be recognized under the microscope in brown oily layers and tyrosin by its sheaf-like bunches of needles. Frerichs's method is more tedious, and consists in precipitating the urine with acetate of lead, filtering, removing the lead from the filtrate with sulphuretted hydrogen, re-filtering, and evaporating the filtrate to a small bulk on a water-bath. From this concentrated filtrate tyrosin and leucin separate spontaneously as above.

Meningitis, according to Bouchut, often coexists as a complication, caused by the original malady of the liver. In such cases the result obtained from the physical examination of the liver, conjoined with other salient symptoms, ought to enable one to recognize the hepatic disease as the fundamental one.

Acute yellow atrophy may be differentiated from typhoid by the slowness of the pulse (60 to 70) in the initial stage of acute yellow atrophy and by the more or less intense yellow coloration of the skin observed therein. Moreover, pains are complained of, at first in the right hypochondriac region, thence spreading at times into the shoulder or just below the shoulder-blade.

The liver in fatty degeneration is not appreciably softened, and is somewhat diminished in size, but in simple fatty degeneration there is no leucin nor tyrosin found in the urine or in the liver, but only in numerous fat-cells instead. But in extreme cases of fatty degeneration differentiation is almost impossible.

In severe cases of fatty degeneration the urine is loaded with bile-pigments and acids, and the cases end fatally with mania, convulsions, and tetanic spasms. In such cases extravasation of blood under the skin or mucous membranes is liable to occur, and differentiation is almost impossible (Steiner).

**Prognosis.**—The most favorable report found is that of Bouchut, who says, "Death is the usual result in this disease, which may, however, terminate favorably." The general rule, however, is that a fatal result is arrived at within a week: there are exceptional cases in which the prodromal stages last a couple of weeks, though, as a rule, death ensues within five days after the development of high temperature and insomnia. It is doubtful if there is any well-authenticated case of recovery from acute yellow atrophy in children, unless it may have occurred in some of the milder forms of phosphorus-poisoning, and in these, in all probability, the supposed yellow atrophy had not proceeded further than simple re-absorption jaundice, for it is difficult to perceive how liver-cells after they have become disintegrated may be restored (Bartholow). The progress of the disease is irregular, and the duration of the preliminary stage of icterus is uncertain, but the closing toxæmic stage almost uniformly terminates fatally within five days.

**Treatment.**—Bouchut's treatment consists of "the free use of emollient or diuretic drinks containing bicarbonate of sodium or acetate of potassium:

this, with the application of several leeches over the liver at the beginning of the disease, is the only thing of value in the way of medication." The child should be fed with soups or milk (diluted), and if there is sharp pain the application of poultices containing laudanum may be useful.

Except Bouchut's, the writer as yet has been unable to find an account of a case of yellow atrophy successfully treated in a child. Frerichs claims to have cured one in the adult with purgatives and mineral acids, the use of which in children would be of course justified by such undoubted authority. On theoretical grounds, the early internal use of the salicylates might be of value.

Bartholow recommends the use of morphine before the liver-cells begin to disintegrate, after which alcoholic stimulants should be pushed to their fullest extent. The use of minute doses of phosphorus has not been followed by any beneficial results, although advised by high authority.

#### ASCITES.

**Synonymes.**—Abdominal dropsy, Dropsy of the peritoneum.

**Definition.**—Abdominal transudation of fluid into the peritoneal cavity, due to interference with the hepatic circulation caused by cirrhosis of the liver or other agencies which produce pressure upon the portal circulation.

**Varieties.**—Passive, peritoneal, obstructive, etc.; but it should be remembered that an accumulation of serum in the peritoneal cavity is never a primary disease, but only a symptom of general dropsy or of some local affection of the abdominal cavity.

Etiologically, Steiner divides ascites into (*a*) hydræmic, (*b*) mechanical, or that arising from obstruction of the venous circulation by cardiac, pulmonary, or peritoneal lesions, and (*c*) neoplastic, or that due to abdominal tumors, cancerous or otherwise, especially lymphatic tumors, more commonly located in the hepatic notch.

**Etiology.**—Dropsy is not *per se* a disease, but is a symptom common not only to syphilitic or other disease of the liver in childhood, but also to other disorders of the circulation, and to hydræmic disease of the peritoneum. In the adult, general dropsy is perhaps most frequently due to renal disorder; in the child, to cardiac lesion, especially of the tricuspid valve (Kormann). Such pulmonary diseases as atelectasis or emphysema are not infrequent causes of ascites, but syphilitic gummata and pylephlebitis of the liver are its most frequent causes in children, so much so that the appearance of ascites in the child without other known cause always justifies resort to antisyphilitic remedies as an aid to diagnosis. Again, it may arise from splenic enlargement caused by malarial poison, or, as in the adult, it may be a symptom of Bright's disease or of the nephritis following scarlet fever. Furthermore, the pressure of infiltrated or waxy lymphatic glands upon the vena cava inferior or the portal vein may cause ascites. Again, ascites is found accompanying hydrothorax and the general œdema due to hydræmia. Lastly, ascites—though more rarely than that from previously

mentioned causes—may be due to tuberculosis of the peritoneum, which causes a chronic peritonitis and consequent obstruction of the peritoneal circulation.

Grancher asserts that if the fluid is localized in one part of the abdomen, immovable, and not excessive in quantity, it is probably due to tubercular peritonitis, especially if there is evidence of tubercular trouble elsewhere; though, as a rule, ascites and tubercular peritonitis do not coexist. Excluding cardiac and renal lesions, which are comparatively infrequent in childhood, by far the most frequent cause of ascites in children is cirrhosis of the liver, which may always be suspected when the fluid is large in amount and movable (Terillon).

Pulmonary troubles rarely give rise to ascites in young subjects, and the same is true of interstitial nephritis, which is more prone to result in general anasarca. Profound anæmia may cause ascites, but this is infrequent except as a complication in profound malarial poisoning. (See Malarial Cirrhosis.)

**Pathology and Pathological Anatomy.**—The pathology of ascites can be better understood if it is remembered that its primary lesions exist either in the peritoneum or in some obstruction to normal circulation through the portal veins, due to gummata, cancerous growths, hydatids, or cirrhotic change in the liver or kidneys, etc.

According to Terillon, serous effusions in the abdominal cavity may be due to one of two distinct conditions of the peritoneum,—viz., (*a*) the peritoneum is reddened and velvety in appearance, or (*b*) the peritoneum is pale and shows no trace of inflammatory action. Quinn thinks such ascites is due to a peculiar condition of the peritoneum, which is found covered with inflammatory granulations and looks as if sand had been strewn over it.

The presence of ascites with tumor suggests the malignant character of the latter; but ascites may also coexist with benign tumors, though such cases are exceptional.

**Complications.**—Collapse of the base of the lungs is by no means an infrequent complication. Next in frequency ought perhaps to be mentioned œdema of the feet and ankles, caused by the presence of the fluid in the abdomen. Peritonitis, if present, gives its usual post-mortem appearances, previously described. Splenic enlargement may be expected when the ascites originates in cirrhosis of the liver.

General anasarca occurs as a complication in ascites according as the results of vascular congestion are confined to the peritoneum or not (Caillé). As a result of large effusions, the liver, spleen, and kidneys may become anæmic, the secretion of urine diminished, and the diaphragm crowded up to the second or third rib. Œdema of the ankles, limbs, and genitals may ensue.

**Symptoms.**—There are no characteristic prodromal symptoms of ascites, though an effusion of fluid into the peritoneal cavity may be pre-



ceded by chilliness, headache, vomiting, abdominal pain, emaciation, and spasmodic attacks of diarrhoea lasting for a day or so (Eustace Smith).

Ascites, as a rule, is not painful, unless it proceeds from peritonitis. Indigestion and irregularity of the bowels, as might be expected from the abdominal tension, are generally present in such cases. The skin is dry and of an earthy tint. The physical signs are those of a mobile fluid in the abdominal cavity, whose examination ought to be painless. Ascitic fluid changes its position with gravity: hence the abdomen will be noticed to be largest below while standing. When the child lies on its side, the abdomen spreads out laterally and gives a characteristic sense of fluctuation or undulation. Small effusions are more easily detected in the sitting or in the lateral position, but often are found with difficulty even then. Large effusions render the skin of the abdomen tense and shining, and sometimes produce the striae of hyperdistention seen upon the abdomen of a pregnant woman. The navel is often protuberant, and may be surrounded by a net-work of dilated veins, known as the *caput Medusæ*. The temperature remains normal unless some inflammatory complication is present. The urine is variable in amount, often scanty, high-colored, and containing albumen and fibrinous casts.

Increasing abdominal pressure at last renders the passage of feces difficult and produces dysuria, or incontinence of urine. Continued upward pressure of the diaphragm, which may be found as high as the second or third rib, causes dyspnoea, often aggravated by hydrothorax, until death results, either from exhaustion or from asphyxia, the child at last being unable to lie down at all.

**Differentiation.**—A case of ascites to which the tests of palpation and percussion can be successfully applied could hardly be mistaken for anything else, but it should be remembered that a protuberant abdomen from other causes than ascites is often met with in children. On the other hand, a moderately large effusion is necessary to distend the cavity sufficiently to give clearly the physical signs of fluctuation. Fluctuation—or, rather, undulation—may best be recognized by placing one hand open against the abdomen and tapping sharply with the fingers on the opposite side of the abdomen. An abdomen filled with serum ought to convey a wave-like impression to the outspread hand. Percussion over the most prominent part where the intestines float highest gives a clear percussion-note which alters its position with that of the patient. If the child lies on its back the lower and lateral regions of the abdomen give a dull percussion-note. This, and the peculiar mobility of the percussion-note already mentioned, usually serve to clear up the diagnosis.

**Prognosis.**—Differentiation as to the etiology of the ascites is often valuable in the way of prognosis. That form of cirrhosis which produces ascites is mainly the atrophic variety, which, consequently, gives us a liver diminished in size. Disseminated nodules characterize tubercular peritonitis, in which there are usually tenderness upon pressure, fever, and pain.

The prognosis is not necessarily hopeless, though in general discouraging. If the primary cause of the ascites is removable, as malaria or alcoholism, and only a limited portion of the liver is affected, it is not unreasonable to hope that the entire removal of the cause, with intelligent hygiene assisted by proper medication, may effect a cure if the quantity of the fluid oozing from the peritoneal surfaces is small and the collateral circulation is fairly preserved.

Goodhart believes that in tubercular peritonitis the prognosis is better for the child than for the adult, as proved by the post-mortem table.

**Medical Treatment.**—If the ascites is slight, administer such diuretics as acetate of potassium, juniper-berries, or infusion of digitalis. If there is no heart-lesion, try fluid extract of apocynum cannabinum. When anasarca complicates, try the sweating cure as recommended for scarlatinal dropsy, with a strict milk diet conjoined. Tonics, iron, and good air are indicated where there is concomitant hydræmia.

In the ascites of atrophic cirrhosis Hurd highly recommends a pill composed of equal portions of squill, digitalis, and calomel.

Ordinary diuretics have little effect upon this form of ascites, in which E. Smith highly recommends the use of Basham's iron mixture. (See Cirrhosis.) If this fails and the fluid continues to accumulate, recourse must be had to the surgical treatment of ascites. W. H. Thompson and others advise that this should be adopted early, believing, with Dujardin-Beaumetz, that in the majority of cases diuretics, and especially purgatives, have no effect in removing the abdominal effusion, and that, for obvious reasons, when these medicines are too long continued the general condition of the patient is injured rather than improved: nevertheless, Dujardin-Beaumetz delays tapping as long as possible, resorting to it only for relief of threatened asphyxia.

**Surgical Treatment.**—Interference with the action of the diaphragm ought to be a sufficient reason for mechanical relief from dropsy by tapping. It carries with it slight, if any, danger to the child, and may be accomplished by the aid of the aspirator or a fine trocar, and repeated as often as required. Dujardin-Beaumetz's rule in regard to tapping is that if the subject is young, vigorous, and possesses good digestion it is wise to tap early, but even in such cases if refilling takes place rapidly—say, in three or four days—retapping should be delayed as long as possible; while if it takes two or three weeks for the peritoneal cavity to become full again, paracentesis may appropriately be repeated at the end of that time. The operation is simple and safe, provided two precautions are taken,—viz., first of all, be careful as to the place where you make your trocar-puncture, in order to avoid wounding any enlarged or distended veins, which in the cirrhotic ramify abundantly upon the abdominal wall; secondly, after the tapping is terminated see to it that the patient lies on the side opposite to that where the puncture was made, and that he keeps that position for some time, in order to enable the wound to cicatrize. You will thus avoid those

fistulæ which often remain behind, and which are exceedingly disagreeable, for they soil the patient's linen and produce cutaneous inflammation.

A. Caillé highly recommends permanent drainage by means of a rubber tube and proper antiseptic precautions whenever in ascites the fluid rapidly accumulates after one or two tapplings. The number of successful cases on which he bases this advice is as yet too small to do more than encourage, but they are sufficient to justify recourse to this method when all other measures are apparently hopeless. Very remarkable results are reported by the German physicians of a similar operation in tubercular peritonitis in the adult.

## PART II.

### DISEASES OF THE GENITO-URINARY ORGANS.

---

## ANOMALIES OF THE KIDNEY:

### NUMBER, FORM, AND POSITION.

By GEORGE B. FOWLER, M.D.

---

LIKE many other organs, the kidneys are subject to variations as regards *number, form, size, position, and mobility.*

Such anomalies are not necessarily conducive to disease of these organs, and have, therefore, until quite recently been matters largely of anatomical curiosity. Now, however, since abdominal surgery has made such successful strides, and since some of these conditions are known to produce certain hitherto uninterpreted symptoms, the subject at once assumes great importance.

#### NUMBER AND FORM.

Anomalies of number and form are generally associated. In very rare instances one or two supernumerary kidneys have been discovered, each being provided with a separate ureter. Rayer, quoted by Roberts, has seen in still-born infants entire absence of both kidneys, ureters, and bladder. This observer thinks that acephalous monsters most frequently present this peculiarity.

The existence of only one kidney has quite often been observed. This state of things is due in some instances, it is thought, to the great mobility of the embryonic element of the organs, and to their tendency to fuse when in contact; and complete or extensive fusion gives the appearance of a single organ. If the fusion is extensive, and has occurred at an early period of fetal life, the resulting organ may bear more or less resemblance to the normal one; but is lobulated, globular, and generally displaced, lying in

the median line, on the spinal column below the bifurcation of the aorta, on the promontory of the sacrum, or even lower down in the pelvis. Such a kidney generally has two ureters (Fig. 1), and its blood-vessels present anomalous arrangements.

The real single kidney exists as the result of congenital atrophy of its fellow. The remaining organ then takes on an overgrowth, and is often displaced downward, perhaps on account of its increased weight. Such kidneys, the "unsymmetrical," may lie in the pelvis or iliac fossa of the same side. The ureter of the missing kidney may be entirely absent, or may be present in the shape of a rudimentary canal with its upper extremity blind and buried in the connective tissue of the surrounding parts. Some instances have been cited where there was imperfect development of the generative organs on the same side as the absent kidney,—the vas deferens, testicles, and seminal vesicles or the uterine appendages. Roberts cites a case of epilepsy observed by Dr. Lecch, where solitary kidney was associated with double uterus and vagina. From the above description it is apparent that the fused kidney, although appearing so, is not really a single organ, and a solitary kidney, strictly speaking, exists only in those instances where its partner has suffered congenital atrophy.

This latter is a rare occurrence. Beumer<sup>1</sup> in 1878 collected forty-eight cases, and it is estimated that not more than seventy or eighty have been reported up to the present time. Out of eleven thousand nine hundred and seventy-eight autopsies made at the four largest London hospitals, only three instances of marked atrophy of one kidney were observed.<sup>2</sup> This is a proportion of about one in four thousand. Of Beumer's forty-eight cases twenty-six were healthy. They were all enlarged. Four of the individuals were between forty and fifty years old. Thus it is seen that a single kidney may properly perform the function of two for many years without giving rise to any symptoms referable to the anomaly. But all statistics show that disease is very apt to exist in about one-half of the cases of single kidney, whether fused or real. Especially is calculous impaction common. These facts complicate the question of surgical interference. Added to this liability to disease of

FIG. 1.

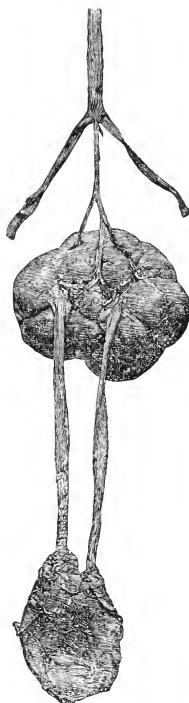

Fused kidney taken from a child three years old, dead of pneumonia, at the New York Infant Asylum.

<sup>1</sup> Virchow's Archiv, Bd. lxxii. S. 344.

<sup>2</sup> Ransohoff, Hand-Book of Medical Science, Wood, vol. iv. p. 300.

the kidney is its tendency to be displaced, and, not being recognized in its abnormal position, it may be removed. Polk<sup>1</sup> published such a case, the patient surviving eleven days, with no kidney at all, and with complete anuria. Roberts<sup>2</sup> collected twenty-nine cases of solitary, or unsymmetrical, kidney, of which the following is an analysis: "Twenty-two were males, six females, and in one the sex is not stated. One was a male infant seven days old; another, a boy of seven years; two of the cases were fifteen years old; four were between twenty and thirty, three between thirty and forty, four between forty and fifty, two were sixty, and one was sixty-five; the remainder were adults whose age is not specified. The left kidney was absent in sixteen cases, and the right in twelve; in one the side is not mentioned. In nineteen the defect was congenital; in three it had been acquired later in life, through destruction of the opposite organ; while in seven it is left uncertain whether the defect was congenital or acquired. The renal vessels and the ureters were always absent in the congenital cases." In twenty-four cases in which the cause of death is given, ten were due to impaction of calculus.

Fusion of the two kidneys, as has been intimated, may exist in various degrees. The union may take place at the two lower extremities, in the middle, or at the upper borders. When united at either of the extremities the "horseshoe" kidney is the result. This, indeed, is the most common of the anomalous varieties as regards form. The uniting bond may consist of connective tissue, or, what is more generally the case, of true glandular substance.

The prevailing rule is that the kidneys thus joined are united at their lower extremities, and have two ureters which usually pass over in front of the connecting isthmus. The two organs lie close up to the spinal column, and are displaced downward.

FIG. 2.

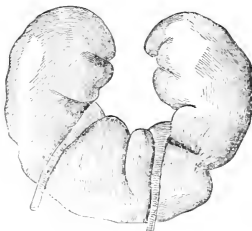

Horseshoe kidney from an infant.

Fig. 2 represents a horseshoe kidney taken from an infant four months old, by Dr. F. M. Warner, at the New York Infant Asylum. The child had pertussis and died in convulsions. No urinary disturbance was evident. "Horseshoe" kidneys were found nine times in fourteen thousand three hundred and eighteen autopsies made at St. Bartholomew's, Guy's, Middlesex, and Great

Ormond Street Hospitals, and only one completely fused kidney, other than horseshoe-shaped, in eight thousand one hundred and seventy-eight inspections.<sup>3</sup>

<sup>1</sup> New York Medical Journal, 1883, vol. xxxvii. p. 171.

<sup>2</sup> Urinary and Renal Diseases, 1872. Amer. ed., p. 612.

<sup>3</sup> Ransohoff, loc. cit.

## SIZE.

Marked variation in the size of the two kidneys (otherwise normal) is sometimes observed, and is due, no doubt, to a difference in the size or number of the renal arteries supplying each organ.

## URETERS.

The number and arrangement of the *ureters* are subject also to departure from the normal type. Fig. 3 represents a double ureter of the left kidney, found in an infant at the New York Infant Asylum, the two ducts reuniting about half an inch above their entrance into the bladder. Three such instances of anomalous ureters were detected by the house physician, Dr.

FIG. 3.

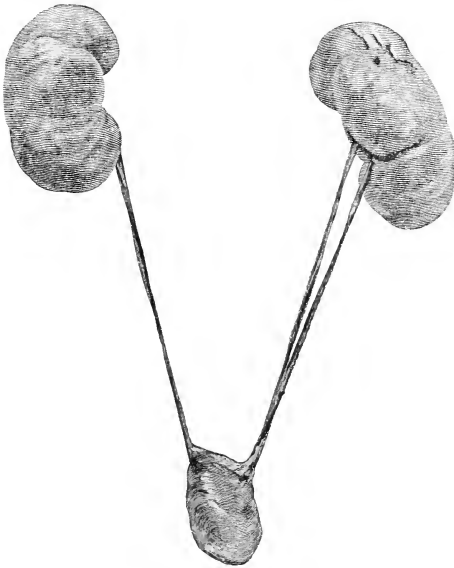

Double ureter of left kidney, from a child two years old, dead of bronchitis.

Davis, in about twenty successive autopsies. Analogous cases have been published by Sir Henry Thompson,<sup>1</sup> Dr. Kelly,<sup>2</sup> and Mr. Wood,<sup>3</sup> and are cited by Roberts.<sup>4</sup> Occasionally one or both ureters may be partially or completely impervious, either from coalescence of their walls, when they

<sup>1</sup> Pathological Transactions, vol. vi. p. 267.

<sup>2</sup> Ibid., vol. vii. p. 261.

<sup>3</sup> Ibid., vol. xix. p. 274.

<sup>4</sup> Reynolds's System of Medicine, vol. iii. p. 741.

resemble fibrous cords, or from the formation of constricting rings of fibrous tissue.

#### POSITION.

We have already seen that abnormalities of number, shape, and size of the kidney are usually associated with displacement of the organ. We shall now speak more especially of malpositions of otherwise essentially normal kidneys. They are of two kinds: fixed and movable.

**FIXED MALPOSITIONS.**—This condition may be acquired or congenital. Pressure of new growths in the abdominal cavity or enlargement of the liver or other contiguous organs is sufficient to push one or both kidneys out of place in various directions and hold them thus. Under such circumstances they are very apt to confuse the diagnosis, and in adult females to complicate labor.

*Congenital fixed malposition* of the kidney has been not infrequently observed, and such an organ is generally more or less malformed. Displacement of the large intestine and peritoneum is also usually coexistent. It has been noted that the suprarenal capsules never follow the kidney in congenital displacement, but remain in their normal places.

Examples of this kind of malposition have been described by a number of writers, and Roberts<sup>1</sup> has collected from these sources twenty-one cases showing that only one kidney was ever displaced, and that in the majority it was the left,—fifteen to six.

David Newman<sup>2</sup> has contributed a very complete study of malpositions of the kidney, and Dr. W. P. Northrup<sup>3</sup> has described two cases of congenital fixed malpositions which were discovered by him in five hundred and fifty autopsies at the New York Foundling Asylum. As these very fully represent the anomalies of position, shape, vessels, and ureters characteristic of this class, we reproduce their histories:

“One history will serve for both: both were females; both three months old; both inmates of the New York Foundling Asylum; both died of chronic gastro-intestinal catarrh in a wretched condition of emaciation; both were without symptoms referable to the urinary tract. In one the malposition was of the left kidney. Both were found in the same month.

“Malpositions and abnormalities were as follows:

“*Case I.* (Fig. 4).—Suprarenal glands both in normal position, without reference to kidneys.

“Right kidney in normal position, its vessels of normal distribution.

“Left kidney. Its superior margin on a level with inferior margin of right, lying mostly in hollow of sacrum, perhaps one-eighth extending above the prominence. Kidney firmly attached by vessels and connective tissue.

<sup>1</sup> Reynolds's System of Medicine, vol. iii. p. 736.

<sup>2</sup> Glasgow Medical Journal, August, 1883.

<sup>3</sup> American Journal of Obstetrics, February, 1884.



*Arterial Supply.*—(1) Small artery given off from angle of bifurcation of aorta entering kidney posterior to and to the right of upper end. (2) Small artery arising on anterior aspect of aorta and just above the bifurcation, which reaches the hilum after passing through a groove on anterior surface of kidney. (3) Much larger artery given off from internal iliac just below its origin (not seen in cut), which passes by a short course into the hilum.

*Veins.*—One leaves the hilum in the same groove by which artery (2) reaches it, passes under the bifurcation of the aorta, and joins the vena cava.

*Ureter.*—About half the length of the right, its arrangement normal.

*Case II.* (Fig. 5).—Right kidney in normal position, surmounted by its suprarenal gland.

“In each kidney there is a double hilum, or two distinct, each supplied with its own arteries, veins, and ureter.

*Arteries.*—One given off from aorta just above its bifurcation, itself bifurcates; one branch going to each hilum. This passes in front instead of behind the great vein.

*Veins.*—(1) One from the upper hilum going directly to the inferior vena cava. (2) An anomalous vein which sweeps up from the iliac fossa over the kidney, receiving a branch from each hilum and one from surface of kidney.

“Left kidney. Position of suprarenal gland not noted. Kidney is situated one-half above, one-half below the prominence of sacrum in the median line.

FIG. 4.

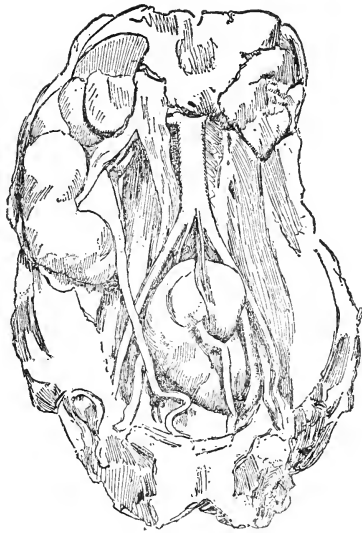

FIG. 5.



*Arteries.*—(1) Small, arises from angle of bifurcation of aorta, passes to lower hilum through a deep groove on inner side of kidney (not shown in cut). (2) Moderate-sized, arising from anterior aspect of aorta just above its bifurcation, itself bifurcates, one branch going to upper hilum, one to extreme upper end of the organ. (3) Two small arteries given off from internal iliac, reaching the lower hilum by way of two deep grooves.

*Veins.*—(1) Small vein, companion of artery (2) above described, arises from two sources, upper hilum and extreme end of the kidney, passes behind the aorta, and joins the great vein just above the junction of the two iliacs. (2) A vein from lower hilum, winding around in a deep groove, finds its way to the vein of the common iliac."

#### MOVABLE KIDNEYS.

Mobility of the kidney, like the anomaly just described, may be either congenital or acquired.

The former are extremely rare, and are usually caused by some abnormality of the peritoneum in its relations to the organ, and irregularity of the vascular connections.

**FLOATING KIDNEY.**—The ordinary movable, or floating, kidney is much more common than is generally recognized. But whether it is acquired or congenital, it seems to me, is not always easy to determine. For its existence may not give rise to any symptoms, and may be discovered only at the autopsy. The old writers were evidently aware of this condition, but gave no comprehensive accounts of it. Within the last thirty years, however, there have been many contributions to the subject, and the latest authors all prove that floating kidney is not a very rare anomaly.<sup>1</sup>

From seventy cases collected by Roberts, a number of which were his own, he makes the following analysis, which, we may say, is in accord with that of all authorities. Of these seventy cases sixty-one were women and nine were men. As regards the kidney affected, sixty-five cases only are available: in forty-two it was the right, in nine the left, and in fourteen both. The ages were from sixteen to sixty-five, and the greatest number between twenty-five and forty.

**Etiology.**—In endeavoring to explain the cause of floating kidney several plausible views have become classical. Cruveilhier considered tight-lacing to be a frequent cause of displacement of the right kidney, on account of the displacement of the ribs and liver thus induced. But, though this pernicious practice may be held accountable for some instances, and though the great majority of cases occur among women, this is not an all-sufficient reason. For it is among females of the middle and lower, or laboring, classes where the displacement is most frequently encountered,—in those who bear the most children and do not wear stays. Most writers

<sup>1</sup> A comprehensive account of the literature of this subject is given by Roberts in Reynolds's System of Medicine, vol. iii. p. 737.

lay great stress upon the influence of pregnancy, and point to the fact that the majority of cases occur, in the first place, in women, and, secondly, in them at the child-bearing periods. Accidents of various kinds, too, are thought sufficient to account for a certain number of cases, such as heavy falls, blows upon the abdomen, etc. Among other causes are emaciation, with absorption of the fat about the kidney, and consequent weakening of its attachments; general relaxed condition of the walls of the abdomen, as a result either of frequent pregnancies or of constitutional vice; and, finally, Becquet<sup>1</sup> believes that the associated congestion of the kidneys recurring at each menstrual period frequently determines their mobility in women. It is not known that such congestion does take place, although Dr. Roberts<sup>2</sup> found increase of sensitiveness and apparent increase of size during menstruation in a patient whose movable kidney he was easily able to grasp.

Bearing upon this point of etiology, the deductions of Dr. David Drummond,<sup>3</sup> which are contained in a very recent and timely article, are of decided value. This author narrates thirty-one cases, all of which came under his own observation, and in which he was unmistakably able to diagnose movable kidney. (But he is careful to say that he does not regard every kidney which presents a certain degree of mobility as a "floating kidney," employing the term to denote a condition of true mesonephron,—which he believes to be very rare.) Of these thirty-one cases twenty-five were women, four men, and two children, both girls. The ages of the females ranged from sixty-six to ten, of the men from fifty-six to twenty-three. Sixteen of the women had borne children, nine had not. Of the sixteen mothers nine had three or less than that number of children, and only five had large families. In eleven of the thirty-one cases there was decided emaciation. But the author very aptly remarks that the emaciation may have succeeded (and probably did) the nervous and digestive disorders so commonly associated with the displacement. Of this series the right kidney was affected in fourteen instances, the left in two, and both in fifteen. Finally, Dr. Drummond thinks that movable kidney is usually associated, without doubt, with a congenitally relaxed condition of the peritoneal attachments, and that the final displacement is determined by any of the various causes generally enumerated, together with another which he would emphasize,—viz., violent descent of the diaphragm, as in vomiting, sudden physical exertions, and asthmatic attacks.

**Symptoms.**—The symptoms are pain, dragging, burning, and lancinating, generally referable to the region of the displaced kidney, and radiating from the back through the abdomen, the groin, and down the thigh and leg. There are frequent attacks of headache, and marked hypochondria is common. Disorders of digestion are very prominent symptoms.

<sup>1</sup> Quoted by Fagge, *Practice of Medicine*, vol. ii, p. 521.

<sup>2</sup> *Reynold's System of Medicine*, loc. cit.

<sup>3</sup> *Clinical Aspects of Movable Kidney*, *Lancet*, January 11, 1890, p. 66 et seq.

and the patient, if a woman, usually considers herself to be suffering either from "dyspepsia" or from "womb-complaint." In this the doctor too frequently acquiesces. There may be intermittent attacks of hæmaturia and albuminuria, from congestion of the kidney induced by twisting of the renal vessels. Or there may be partial suppression of urine, from twisting of the ureter, inducing perhaps hydronephrosis.

All the painful symptoms are brought on and aggravated by exertion, and many patients are unable to walk or ride with any degree of comfort. Constipation alternates with diarrhœa, and the bowels are frequently distended with gas. The stools contain mucus, and there is, indeed, every evidence of gastric and intestinal catarrh. Movable kidney, I am sure, is very intimately associated with vascular disorders relating to the tone of the arteries. In these patients there is always marked abdominal pulsation, and one should be on the alert not to confound the condition with aneurism.

**Diagnosis.**—The symptoms and features just enumerated should prompt us always to bear this deformity in mind. Other evidences are discovered by careful physical examination of the patient. Absence of the kidney from its normal site causes a slight hollowing of the lumbar region, and percussion may elicit a slightly tympanitic note where naturally it should be dull. When the patient stands, the kidney, according to the degree of mobility and the thinness of the abdominal walls, may be felt as a reniform tumor somewhere in the abdominal cavity, generally just below the ribs. But my experience coincides with that of Drummond, that the simplest and surest way in which to detect a movable kidney is for the patient to lie down with the abdomen uncovered and relaxed. The physician then, standing upon the right side, places his left hand beneath the twelfth rib, on the patient's back, while the right opposes it by pressing down upon the side and front of the abdomen, beneath the arch of the ribs. Then ask the patient to take a full breath, and, as she does so, gently relax your pressure so as to allow a possible kidney to slip downward between your two hands, and, as expiration takes place, you will almost certainly detect the movable organ riding up and down with the movements of respiration. The other side can be similarly examined.

**Treatment.**—The treatment of movable kidney is either palliative or radical. The first consists principally in attention to the dyspeptic symptoms and general health. Many patients are relieved by bandages and pads by which they succeed in replacing, in a measure at least, the displaced organ. When violent pain or bloody urine makes its appearance, the recumbent posture must be assumed and maintained until these symptoms pass off. The radical treatment consists in surgical interference with a view to establishing permanent replacement by means of sutures or adhesive inflammation.

# ALBUMINURIA IN CHILDREN.

By JAMES TYSON, M.D.

---

ALBUMINURIA in children may be produced by the following causes : I. Bright's disease. II. Admixture of pus due to suppuration in any part of the genito-urinary tract. III. Hæmaturia and hæmoglobinuria. IV. Chyluria. V. In very rare cases albuminuria may be caused by pressure on the renal veins by tumors or perinephritic inflammation and abscess. VI. Albuminuria may be without apparent cause, when it is called functional albuminuria, or, in children, in consequence of the fact that it is most frequent between the ages of nine and eighteen, the albuminuria of adolescence.

## I. BRIGHT'S DISEASE.

This common cause of albuminuria is considered under its appropriate heading in the article by Dr. Goodhart.

## II. SUPPURATION.

Pus from the urethra is a very rare source of albuminuria in children. With adolescence in boys comes the possibility of gonorrhœa, while purulent inflammation from mechanical and chemical causes may also occur. In girls at an early age rape is a possible cause of gonorrhœa, as well as inoculation from a parent. Caillé has seen a case of such inoculation in an infant five months old.

Leucorrhœa independent of specific cause is sometimes found in quite young girls, even infants, and comparatively frequently in children three to seven years old and older. The cause in these cases is not always easily ascertained, but the condition is generally observed in young girls who are anæmic and have pale, soft skins,—who are, in a word, scrofulous. The indications of treatment in such cases are to build up the general health of the little patient by the use of nutritive food, hygiene, especially bathing, cod-liver oil, and chalybeates and arsenic. These may be aided by the use of astringent washes, which, as a rule, should be of the simplest character.

After the urethra in the male and the vulvo-vagina in the female, the next source of albumin from this cause is the bladder. Inflammation of the bladder from other causes than stone is not very infrequent in young chil-

dren, and especially in young girls; but the most frequent cause of such inflammation is stone in the bladder. Inflammation of the bladder by these causes is recognized by symptoms detailed in their appropriate place. But no case of this kind should be decided without the sounding of the bladder, and in the case of the female the urethra should be dilated by Simon's dilators and the bladder explored by the finger. This exploration should be practised much more frequently than it is at the present day.

Ascending the urinary tract, the kidney and its pelvis become the next seat of the source of pus. When they are associated in the inflammatory process, the term pyonephritis is applied. This association commonly exists, and, indeed, it is not often easy to differentiate the two processes when they occur separately, and to be able to say that the inflammation is confined to one or the other. The causes of such inflammation are obstruction anywhere in the urinary tract from its beginning at the end of the urethra up to the pelvis itself, stone in the kidney, tuberculosis of the kidney, and perinephritic abscess invading the kidney from without. Frequently the inflammation is an ascending one, starting from the bladder. Malignant diseases of the kidney, including sarcoma and carcinoma, are also rare causes of pus in the urine. Pyonephrosis is the term applied to a collection of pus in the kidney the result of pyonephritis, by whatever cause produced. Calculous pyonephrosis is due to impacted stone, probably its most frequent cause in children. Tuberculous or serofulous pyonephrosis is due to tubercular infiltration commencing in the renal papillæ and extending thence in both directions, into the kidney and downward into the pelvis and ureter. The new formation rapidly undergoes fatty metamorphosis and caseation accompanied by suppuration. These will all be described under their appropriate headings, as well as the various forms of tumor which affect the kidney, although these latter are rarely attended with suppuration. They may also cause small albuminuria by pressure upon the renal veins.

It is scarcely in my province to consider the means of determining the exact source of the pus in a given specimen of purulent urine, but I will merely mention, in passing, the case of an adult male extending over four years, during the last three of which he was under my own care, where from the beginning frequent micturition was a most annoying symptom and regarded as evidence of bladder-involvement, and where the autopsy revealed a tuberculous kidney, but a bladder perfectly smooth and free from tubercular disease or inflammation from any cause; also a second case treated for months as a bladder-case by a distinguished surgeon because of an irritable bladder, where subsequently a successful nephro-lithotomy relieved all the symptoms.

### III. HÆMATURIA AND HÆMOGLOBINURIA.

Hæmaturia as a cause of albuminuria may be recognized by the naked eye when the blood is sufficiently abundant, or by the microscopic recognition of the red blood-disks in doubtful cases. Hæmaturia occurs in acute

nephritis, where the amount of blood is usually small, giving rise only to the well-known smoky hue in acid urine or a brighter tint in alkaline urine. In either event it is best to decide the question by the use of the microscope. In chronic nephritis there is sometimes very trifling hæmaturia. Hæmaturia is frequently the result of injury to the kidney,—traumatic hæmaturia. It occurs also as a result of gravel or stone in the kidney. It is one of the commonest symptoms in tubercular disease of the kidney, especially when the organ begins to break down, although it is not confined to this stage and small amounts of blood may occur in various stages of tuberculosis. Carcinoma and sarcoma are sometimes associated with hæmaturia. Stone impacted anywhere in the ureter between the pelvis and the bladder or contained in the bladder itself may be a cause of hæmaturia. Injuries to the bladder may, of course, cause hæmaturia. Morbid growths in the bladders of children are exceedingly rare, and are therefore very unlikely causes of hæmaturia, but when albuminuria is thus caused it is a true hæmaturia. Cystitis from any cause may be so severe as to be attended by hemorrhage. Among the causes of hæmaturia in children producing albuminuria must not be forgotten the malarial poison, although this form is much more rare in children than in adults. A very interesting case of this form of hæmaturia, closely simulating stone in the bladder, in a boy of seven, is reported by Dr. Mollof, of Sophia, Bulgaria.<sup>1</sup>

Purpura and that singular constitutional tendency to bleed known as hæmophilia must be included among the causes of hæmaturia. The latter is often hereditary.

The question of the source of blood in urine is a very important one preliminary to treatment. The only infallible sign that blood in the urine comes from the kidney is the presence of blood-casts,—casts of the uriniferous tubules composed of coagulated blood or of fibrin to which blood-disks are adherent; or the long worm-like moulds of the ureter which are occasionally discharged where the hemorrhage is free, sometimes with extreme colicky pain. With the latter exception, the blood from the kidney is more apt to be intimately admixed with the urine and is less commonly passed in clots, while clots are comparatively common when the hemorrhage is from the bladder. Here also, however, quantity has much to do with the state of the blood: if the quantity be small there are not likely to be clots, even with hemorrhage into the bladder. The possible admixture with urine of menstrual blood has only to be mentioned in passing.

Hæmoglobinuria differs from hæmaturia in the absence of corpuscles, while the coloring-matter resulting from their disintegration contributes the usual red color of blood to the urine. Where there is any doubt as to whether this coloring-matter is hæmoglobin, chemical tests must, of course, be used, as there is no corpuscle present to recognize with the microscope.

---

<sup>1</sup> Bulgarian bi-weekly *Meditzinski-Pregléi*, Nos. 1 and 2, 1889; also *Provincial Medical Journal*, June 1, 1889.

The simplest test is Heller's, performed by heating the urine in a test-tube with sodic or potassic hydrate. The hæmatin is precipitated with the phosphates, giving to the latter a very characteristic blood-red color. Or the spectroscope may be used, or Teichmann's hæmin crystals may be made.<sup>1</sup>

The term hæmoglobinuria should be restricted to those cases of hæmoglobinuria in which the hæmoglobin comes directly from the blood, for it is to be remembered that in certain cases of apparent hæmoglobinuria the red blood-corpuscles undergo destruction very soon after the urine has been passed, and, if microscopic examination were made at the moment of passing, blood-disks would be found present. Ammoniacal alkaline urine quickly dissolves red blood-disks. The most common cause of hæmoglobinuria is malaria. It must be admitted, however, that both hæmaturia and hæmoglobinuria sometimes occur without discoverable cause, when they are called "idiopathic." Hæmoglobinuria has been experimentally produced by the introduction of poisonous substances into the blood, and it is presumable that whatever agent causes the condition enters the blood and dissolves the corpuscles, either in the vessels or at the moment the blood is discharged from them.

**Treatment.**—The treatment of hæmaturia and of hæmoglobinuria is identical. In this connection will be considered only the treatment of malarial hæmaturia and hæmoglobinuria and so-called idiopathic hæmaturia and hæmoglobinuria. The remedy *par excellence* for malarial hæmaturia and hæmoglobinuria is quinine, which is given in appropriate anti-malarial doses, although, in consequence of the comparative harmlessness of the drug, and, especially in southern climates, the dangerous character of the disease, full doses should be given at once. It is to be remembered, too, that children bear large doses of quinine with immunity. If the hæmaturia and the hæmoglobinuria are paroxysmal, the full quantity should be given, so as to anticipate sufficiently the expected onset. As determined by the age, ten, fifteen, or twenty grains may be thus given, appropriately divided. Where, however, the hæmaturia is continuous, as it often is, even when malaria is its cause, the quinine may be administered in doses of from one to three grains every three hours, according to the age of the child, until the hæmaturia ceases or there is reason to believe that the remedy is ineffectual. If quinine alone is insufficient, it should be combined with other treatment of malaria, especially arsenic and iron, the latter co-operating as an astringent. Turpentine has been strongly recommended by some of the writers in the southern part of the United States. Cases which do not yield

---

<sup>1</sup> Filter out the earthy phosphates as above precipitated, place a small portion on a glass slide, dry carefully, and thoroughly mix with the dried phosphate a minute granule of common salt. The excess of salt is then removed, the mixture covered with a thin glass cover, a hair interposed, and a drop or two of glacial acetic acid allowed to pass under. The slide is then carefully warmed until bubbles begin to make their appearance. After cooling, if blood-coloring matter is present, prismatic hæmin crystals are easily recognizable with a power of three hundred diameters.



to the above treatment may be regarded as suffering from idiopathic hæmaturia and hæmoglobinuria. By far the best remedies for these are the natural mineral waters, as those of Rockbridge Alum Springs, the Bath Alum Springs, or the Wallawhatoola Alum Springs,—all in Virginia, U.S.A. I have seen almost magical results from the use of these waters in cases otherwise intractable. Other astringents may also be used, as gallic acid in five- to ten-grain doses four times a day, or persulphate of iron in one-eighth- to half-grain doses. Ergot may also be used for its action on the muscular coat of the arteries. By far the best preparation is the fluid extract, in doses of from five minims to half a fluidrachm, according to age.

#### IV. CHYLURIA.

This term is applied to that condition of the urine in which the constituents of chyle are present. It can only occur as a result of leakage of chyle from a ruptured lymph-vessel into the urinary tract, most likely into the bladder or pelvis of the kidney. Such rupture is the result of obstruction in one or more of the branches of the thoracic duct. One of the best recognized causes of such obstruction is the filaria Bancrofti or its embryo;<sup>1</sup> but all cases of chyluria are not by any means due to the filaria. The term *parasitic* is applied to such chyluria, while the term *non-parasitic* is applied to those cases where the obstruction is due to some other cause. The larval filaria is frequently found in the blood. In chyluria there is found, in addition to albumin, the molecular base of the chyle, which gives the most striking physical feature to the urine, its milkiness. According to the quantity of this present the urine exhibits every degree of diminished transparency from a slight turbidity to a total opacity. If the fat is abundant it rises on the surface of the urine like cream, and it may be dissolved out by ether. Considerable blood is often present, imparting a reddish tinge to the chylous urine. The effects of chyluria may be either none at all, or a gradual loss of strength of the patient, proportionate to the amount of chyle lost.

**Treatment.**—The evident indication for *treatment* for chyluria is rest in bed. It frequently happens that chyluria disappears the moment the patient is placed in bed. Beyond this no effective treatment is known. The condition is of itself often intermittent. Various devices have been at different times suggested for producing pressure upon the chyle-vessels, and thus closing the leaking orifices, but it is exceedingly doubtful whether this treatment is of any avail. Scheube suggests the use of picronitrate of

<sup>1</sup> The adult filaria, or *filaria Bancrofti*, is a thread-worm three or four inches long, rarely found in man. The writer has seen a beautiful living specimen floating in the anterior chamber of the eye of the horse. It will be noted that it is of considerable size and can easily obstruct the vessels. The embryo, on the other hand, often, but not always, found in great numbers in the blood, especially at night, and occasionally in the urine, is a microscopic creature from one-hundredth to one-eightieth of an inch long, and about one-three-thousandth of an inch in diameter.

potassium in doses of from three to ten grains, in pills or capsules, three or four times a day,—on what principle I am unable to say.

#### V. MORBID GROWTHS.

Albuminuria as the result of pressure by morbid growths requires no further mention. In addition to sarcoma, carcinoma, rhabdomyoma, and fibroma, as forms of morbid growth thus acting, should be mentioned hydatid cysts.

#### VI. FUNCTIONAL ALBUMINURIA, OR ALBUMINURIA OF ADOLESCENCE.

By far the most interesting form of albuminuria, next to that of Bright's disease, is the so-called albuminuria of adolescence. By this is meant an albuminuria renal in origin, further characterized by the absence of casts and of all other signs of Bright's disease, or indeed of any disease, as its subject is in apparently perfect health. It is much more common in boys than in girls. The amount of albumin in these cases varies greatly. Sometimes it is quite large, amounting to half the bulk of urine tested, but more frequently it is moderate in amount or very small. It is also greatly influenced by circumstances. Thus, it is apt to be increased by the ingestion of food, and especially by fatigue, and it is almost always entirely absent on rising in the morning, returning with the resumption of muscular activity, whether food is taken or not. The most important injunction in the recognition of this form of albuminuria is a careful and exhaustive examination of the urine for casts, for should one fail to find them when they are actually present a most serious error in diagnosis results. All attempts to explain this form of albuminuria must be based on speculation. Careful thought, however, leads to the suggestion that it may not be so much the result of derangement of the circulation of the kidney as a defect in the composition of the albumin in the blood due to mal-assimilation, in consequence of which defect it transudes through the vessel-walls. In structural change, on the other hand, there is a hinderance to the movement of the blood through the kidney, and from this cause a transudation of the albumin takes place. Up to the present time, however, no chemical researches have been able to discover a difference in the composition of the albumin excreted under these circumstances. Functional albuminuria is by no means confined to childhood.

**Treatment.**—Having once recognized this form of albuminuria in a child, what shall be its management? First and foremost is the diet, and a very nice question it is to settle. A growing child should not be too much restricted in the quantity of food, but care should be taken that it be of the simplest character and most easily digested. Milk is conspicuously appropriate: it is easily digested, and should be freely allowed. Nor should nitrogenous foods be excluded from the diet of such a child. At the same time care should be exercised not to permit the too free use of meat and

of other albuminous foods, such as eggs. Too free eating should also be avoided at the evening meal, which should be of a simple character. For a child "bread and milk" is a typically suitable evening meal. Of equal importance is the regulation of the amount of muscular exercise. Over-exertion and extreme fatigue should be avoided, and competing in athletic sports should be prohibited, because here not only is the exertion excessive but there is also no power to regulate it. Young girls during the establishment of menstruation should be put to bed. On the other hand, out-door life is important for both sexes. It is to be remembered that boys and girls with true functional albuminuria are not ill, but are in a state which may easily be converted into illness, and, while they require to be watched, they are not to be treated as invalids. Medicines are, therefore, scarcely needed except to meet symptoms. Anæmia requires to be treated with iron in *small* doses,—only such as can be assimilated: all over this is harmful, as it is not absorbed, but, remaining in the alimentary canal, acts as an astringent, constipates, and otherwise deranges digestion. It is impossible to direct definite doses, because they must vary with the age of the child, but even with girls and boys of eighteen a fluidrachm of the well-known Basham's mixture of acetate of iron is quite enough. It should further be freely diluted, as its absorption is thus favored and the astringent effect diminished. As a rule, too, the vegetable salts of iron are by far the best, because they are more easily assimilated. Such are the citrate, tartrate, and malate of iron, in doses of from half a grain or less to two grains. In girls at all disposed to chlorosis, arsenic is a valuable addition, in the shape of Fowler's solution or arsenious acid. The well-known Bland's pills of carbonate of iron are useful, but I doubt whether they are any more efficient than the freshly-made pills of the same substance.

# ACUTE AND CHRONIC BRIGHT'S DISEASE.

By JAMES F. GOODHART, M.D., F.R.C.P.

---

THE term Bright's disease has now for so long a period occupied a recognized position that, although it is an interesting subject of study to trace out from a utilitarian point of view the development of this as of every other progressive advance in medicine, there is little need to occupy time here either in a history or in a definition of the malady.

Nevertheless, as regards the latter I will say thus much, that, excepting abscess, which will not concern us, any inflammation that attacks the secreting structure of the kidney, whether that inflammation be catarrhal or interstitial, partial or general, is essentially Bright's disease more or less, and any less comprehensive definition leads not to perspicuity but to perplexity, for it is some such wide embrace as this alone that admits of any attempt to explain the many varieties of symptoms and groups of such which severally present themselves. Upon this point, therefore, I would venture to insist: it is of cardinal importance to the subject as presented in this article.

*Plan.*—In any article on Bright's disease there are many interesting questions that are of the essence of the subject which invite attention and discussion. Such, for instance, are the cause of the anasarca and of its presence or absence in particular cases, the problems that centre round arterial tension, and so on. But I have throughout kept rigidly before me that childhood only is my sphere on the present occasion, and, in consequence, only such points in the general pathology of nephritis are touched as are within the limits of this restriction, or as seem to be in any measure elucidated by their occurrence under the particular conditions. For the same reason I have avoided any general description of nephritis.

There are many methods of handling the subject. Some treat of it clinically, and describe an acute, a subacute, and a chronic form,—all more or less associated with dropsy; and the granular kidney where dropsy is absent. Others subdivide the subject pathologically according to the supposed change in the kidney, when we have a tubal, a glomerular, and an interstitial nephritis. No one of these commends itself entirely to my judgment, because, as I shall venture to maintain, the several subdivisions

frequently overlap one another, and, after much consideration, I have decided to make a very general division and to treat of only two groups: 1, acute Bright's disease; 2, chronic Bright's disease.

Under the first heading will be included not only the cases of definite and stormy onset and moderate duration, but also all those chronic processes that are known to come about in some cases by such means, although it is possible that they sometimes start in more leisurely manner, and certainly by their prolonged course deserve the name of chronic. This group will therefore include the acute, subacute, and chronic desquamative, tubal, or parenchymatous nephritis of the several authorities, and the obvious justification for classing them all together thus is that it is impossible to give any specific differences that will suffice to distinguish them. There is no dividing line, the disease is the same for all, whether acute or chronic, and the symptoms of any one are more or less those of the others.

Chronic Bright's disease will be practically conterminous with the contracted or granular kidney. There is indeed another condition which is chronic from the commencement,—viz., the chronic parenchymatous nephritis that is set going by lardaceous disease; but its symptoms are those of the late stage of parenchymatous nephritis, and to treat of it separately would only be to repeat myself.

If at first sight the arrangement here adopted seems to be wanting in precision, I think it will be found to work out satisfactorily, and as nearly in accord with practical usage as can be hoped for.

---

## ACUTE BRIGHT'S DISEASE.

**Synonymes.**—Tubal nephritis, Parenchymatous nephritis.

**Etiology.**—In adults the great proportion of cases can be traced to exposure to wet or cold or both. Almost all other causes are obscure in origin, but in some it arises after scarlatina or other blood-poison, be it diphtheria, typhoid fever, erysipelas, or acute rheumatism; in others the patient has been for long markedly anæmic. Sometimes it is associated with drinking habits. Sometimes, started by lardaceous disease, it soon assumes a dominant position and the original mischief is completely masked. But in children it has often been the subject of remark that it is but seldom that any exposure can be traced, and for the most part scarlatina is held to be its common cause. Ralfé states that two-thirds of all the cases of acute nephritis under sixteen years are due to this exanthem; Henoeh, that one can boldly assert that, with the exception of an extremely small number of cases, diffuse nephritis in infants is of scarlatinal nature;<sup>1</sup> and Dr. Dickin-son, that of fifty-four fatal cases the disease was traced to wet or cold in

---

<sup>1</sup> Vorlesungen über Kinderkrankheiten, 1881, p. 510.

only four. At the same time let it be remarked that a chill is not an easy thing to trace in childhood, and, now that we are becoming familiar with the fact that nephritis is more common in very young children than used to be supposed, it is yet possible that exposure may play a more prominent part as a factor in its production than these statements would lead one to suppose. Of other causes fertile in adult life in initiating the more chronic form of the disease, and which ought not to be omitted from some share of responsibility even in childhood, are phthisis and lardaceous disease. Neither is of any great numerical import; nevertheless, it may be as well to insist that lardaceous disease, even in slight degree, is a provocative of chronic parenchymatous nephritis, and even of more insidious changes such as may ultimately bring about a granular kidney.

**Pathological Anatomy.**—If we refer to the many authorities who have written on this part of our subject, it must still be held that there is weighty opinion in favor of two contentions: there are those who still hold that the disease is of epithelial origin; others, that it is essentially an acute interstitial change with consecutive epithelial disturbance and proliferation. Barthez and Sanné, after citing these two views, continue, "Others, in the desire to reconcile these opposite opinions, have conceived the existence of a mixed or diffuse nephritis." But, in my opinion, the assertion that the disease is a complex state of tubal and interstitial change rests upon solid ground; for it is based, first of all, upon a number of recorded facts, and, secondly, upon the *a priori* argument that it is exceedingly unlikely that in any solid and closely-packed organ like the kidney, and which wants the excuse of separate functions such as the liver may supply an example of, or the openness of texture and thus the greater or less independence of the elements of its structure, as is seen in the lung,—I say it seems to me highly improbable that there should be two specifically distinct forms of inflammation or structural change. Physiology and anatomy alike make it more than probable that unity runs through all forms of nephritis; that it is, in fact, impossible for any disease of the tubes to exist any length of time except more or less interstitial disease accompanies it; and that it is equally impossible for any interstitial disease to exist independently and not to entail a tubal disturbance or desquamation. To this it will be at once objected that a dogmatic statement of this kind flies in the face of obvious every-day fact. Take a typical case of the large white kidney—and what more common?—and contrast it with the granular kidney, also too familiar to us all, and the two are so unlike that any *a priori* argument such as I have ventured to employ is of no value, and particularly so when the dissimilarities are in accord with the minute investigations of many most reliable observers. And I admit the cogency of the objection unless it can be satisfactorily disposed of. Let us see whether this is so. It is no mere truism to say that inflammation wherever we study the process is hardly in any two cases alike, because it is this very feature of inconstancy—whether this be due to the disease or to the personality of the individual, who shall

say?—that is forever demanding attention, puzzling our diagnosis, and too often eluding our forecast. And to no other feature than this is it necessary to look for an explanation, and I think a satisfactory one, of the various morbid appearances met with in nephritis. From reasoning based upon the premises thus supplied, it is not difficult to construct a synthetic scheme of the morbid changes of renal inflammation, as follows :

The most acute form of inflammation, from what is known of the process in all tissues, must necessarily be mainly an intense arterial flux. It is impossible to get fire without fuel, and no epithelial proliferation can take place without preceding hyperæmia of some kind, and it is possible to conceive of a vascular condition of this kind so intense as will practically put a stop to further changes by the extreme disturbance of the circulation thereby induced. In the case of the kidney extreme congestion of the Malpighian tufts—a common occurrence—is the initial disturbance, and this would be followed in a smaller number of cases by exudation and damage to the structure of the tufts themselves. In this description any one can see the picture of the essentials of the so-called glomerular nephritis.<sup>1</sup>

In the same way suppose the circulatory stasis to be less severe but its stress sufficiently maintained, and it would be strange if there did not follow an outwandering of corpuscles and other disturbances of the walls of the vessels and of the surrounding parts such as would readily correspond to the description of an acute interstitial nephritis. Far and away behind these in the matter of intensity would come such a flux as would allow of epithelial desquamation, and in cases where this morbid change was excessive one might even hazard the surmise that the attack was chronic. One might even go further, and say that in all such cases as have been really acute one would expect to find such a blending of circulatory—that is, interstitial—changes with the epithelial—or tubal—that the latter should be, after all, not so very prominent.

Most chronic of all would necessarily and obviously be those contracting forms of disease that have received the name of “granular kidney.”

This description—subject to the qualification already insisted upon, that absolutely pure cases are the exception—will account for a considerable amount of variation in the appearance of the kidneys, as also for intermediate cases as regards the symptoms exhibited.

This scheme, be it observed, is altogether beside the knowledge obtained from the clinical and post-mortem study of the disease itself; it is purely hypothetical, and we must now inquire how it works out in practice.

Now, the one feature of the morbid anatomy of Bright's disease as seen in childhood that has impressed itself upon my mental vision is this: that the naked-eye appearances of the kidney are not at all in proportion to the severity of the symptoms; and in my own experience a typical large white kidney is but seldom found. Many a time, with all the symptoms of that

<sup>1</sup> For a very similar view see H. Ashby, *Med. Chronicle*, vol. iii. pp. 187-189.

disease—the pallor, the dropsy, the scanty, smoky urine, with much albumin in it—the kidney by a casual observer might have been passed as healthy. To careful scrutiny there is no doubt about the disease. There is the patchy dilatation of the surface capillaries, and a generally-distributed but subdued fawn-colored speckling. Still, the general aspect is by no means striking: the kidneys, perhaps, are not unduly large, their color might easily pass for that of a pale or what is often called a fatty kidney (a familiar term in the post-mortem room, and carrying no suggestion of parenchymatous nephritis), and their section shows none of that extreme contrast between the lividity of the medullary and the pallor of the cortical parts. Passing on to the minute examination of such organs, I have been further struck with the want of uniformity that is to be found in the histological changes: kidneys of very similar external appearance will show in one case much glomerular change, in another much tubal, in another more diapedesis, in another very little of anything except intense congestion of the vessels behind the tufts. The most recent histological investigations are much in accord with this. Barthez and Sanné, as the result of their most recent summary, state that in all cases of parenchymatous nephritis, whether consequent on scarlatina or on some other malady, the initial departure is a glomerular and vascular one.<sup>1</sup> So much is this want of uniformity a feature of nephritis in childhood—it is by no means wanting in adult life also<sup>2</sup>—that when asked—as, necessarily, often happens—what kind of kidney is to be predicted in a particular case, although it is easy to say in the rough that such and such minute changes will be found, I hesitate always to say what the coarse appearances will be.

I take it that this statement of the case is equivalent to saying that the average of disease in childhood is *acute*, whereas in adults the average is *chronic*. There can be no doubt of this: that the prognosis for parenchymatous nephritis as regards complete recovery is largely a question of *age*. In childhood it is mostly good; in young adults, also, often good; but as years go on it certainly becomes less and less so, and in a large proportion of hospital cases (mostly of middle age) admitted for albuminuria and dropsy, although the immediate risk may not be great, and many are much relieved by treatment, the albuminuria persists, and the ultimate issue, even if long delayed, is unfavorable.

But in this I am anticipating. It is, however, necessary to say so much, because the different behavior of the disease at the two epochs forms part of the argument upon which I base the contention that there are other phases of acute nephritis more acute or intense than the so-called acute tubal nephritis, and that this last is not *par excellence* the disease of childhood, but that, on the contrary, there are strong grounds for supposing that in many cases it is the result of insidious chronic disease.

<sup>1</sup> *Maladies des Enfants*, 3d ed., vol. ii. p. 683.

<sup>2</sup> See a paper by the author, *Guy's Hosp. Rep.*, Series III., vol. xxvii. p. 135.



This view will, I think, receive still further support from the clinical history of the disease.

**Symptoms.**—These will be best brought home to the mind of the reader if they are presented not separately, but as they are moulded into form by the disease. We are all familiar with the symptoms of acute Bright's disease as a mere matter of enumeration,—the pyrexia (I think, occasional only, and usually of moderate intensity), the pallor, the vomiting, the convulsions sometimes; then the dropsy, the cough, the oppressed breathing, the pulse that intermits now and again, the scanty urine, its blood, its smokiness, and its large percentage of albumin. But what we want to know more especially is, how do the individual elements adjust themselves, with what body do they come?

The common history is this: the child becomes dropsical and pale: in consequence of these two symptoms, perhaps only of the swelling that has been noticed in the face, the doctor is summoned; and he finds that the urine is scanty, perhaps even this not remarkable, but the color is dingy, or, as it is called, smoky, it contains a large proportion of albumin, and under the microscope red blood-corpuscles are found, a number of leucocyte-like bodies (probably the nuclei of the renal epithelium), other cells in less proportion, and abundant hyaline casts, of a size denoting that they come from the cortical part of the gland. If inquiry be made, a history of some slight preceding malaise may be elicited, of any length from four or five days to a month, perhaps of some moderate pyrexia. This is about all that can be said of the onset of the average run of cases, but there is a good deal of latitude in all directions. Thus, as regards cerebral symptoms, the disease is sometimes ushered in by convulsions, or there may be early obstinate vomiting, but these are less common, and headache is not a feature of the nephritis of childhood,—or perhaps, to speak more guardedly, it is seldom complained of as such.

If the case does well, after more or less time has elapsed the albumin perhaps begins to vary and on the whole to lessen gradually in quantity, the dropsy decreases and then goes, the urine becomes more copious, its specific gravity improves, perhaps lithates appear, and ultimately the child improves in flesh and color. If, on the other hand, the case progresses downward, the albumin remains in quantity for a long time and the amount of urine is scanty; after a time the diuresis becomes more free, and often much of the dropsy goes, but the child remains pale and emaciated; the albumin persists, and death ensues by one of several complications after perhaps many months. With this history of the common case the separate symptoms may be considered more in detail.

*Convulsions* at the onset, or indeed at any time, are usually associated with and preceded by a markedly scanty urine or even by temporary suppression. They are likely to cease in the course of a few hours under the influence of treatment and of the establishment of a more free secretion of urine.

*Vomiting*, if severe, is more likely to be associated with unusual pallor, a hollow-eyed collapse, restlessness, cough, a diffuse bronchitis of the larger tubes, so that the chest is pervaded, sometimes quite rapidly, with râles of all kinds, the so-called œdema of the lung. This is not always the case: vomiting is sometimes severe when the child is still in a fairly good condition, and it does not then appear to add to the gravity of the case (Henoch). The ejecta are sometimes bilious or greenish, sometimes watery, sometimes mere mucus.

*Pyrexia* is sometimes high (103–104° F.), but it is seldom more than 101°, often below this and altogether overlooked, and in any case it is seldom of any duration. The temperature is often subnormal. Barr states that post-scarlatinal nephritis always sets in with more or less febrile disturbance.<sup>1</sup> I have occasionally noticed the accession of a sharp febrile attack of perhaps two or three days or less, in the course of an acute nephritis. It has speedily subsided, nor has it been associated with any relapse in other ways, but when it has occurred, and this in intensity, the pulse has become for the time a characteristically dirotic one. In the primary nephritis of infancy, too, a pyrexia of some degree and duration is perhaps not uncommon: Emmett Holt has given charts of several such.<sup>2</sup>

The *wine* almost always contains a large quantity of albumin at the onset, unless we have regard to a special and rare group of cases, to be mentioned presently, in which the anasarca is extreme and the albumin absent. The quantity passed in the twenty-four hours varies considerably. Ralfe states that the general average is in his experience from 6 grammes to 13.5 grammes in the twenty-four hours, but Dickinson, according to the same authority, has recorded cases where the amount has been as much as 21.9 and 32.5 grammes.<sup>3</sup> It may vary in quantity, and sometimes much so, from day to day. I could give several charts where in the course of a long attack the estimated quantity jumped about from day to day, and sometimes temporarily disappeared altogether. In other respects than the albumin the urine may also vary much. It is usually scanty at the onset, and it may long remain so, or it may quickly become copious; it may be fully charged with blood, when it is of the color of claret,—a state of things that is in my experience decidedly uncommon. More commonly it is of a definite blood-tint (like raw-beef juice) or only smoky. If the case is of any duration I have often noticed blood to appear and reappear in the course of the illness without any other change in the symptoms, and without, so far as I know, adding anything to alter the prognosis.

Of *polyuria* and *thirst* I shall speak presently. They are not common, but may occur in very chronic cases.

The *dropsy* is usually a persistent symptom, but not necessarily so: it may be that with rest and treatment it quickly disappears, its disappearance corre-

<sup>1</sup> Archives of Pediatrics, 1887, p. 525.

<sup>2</sup> Ibid., 1887.

<sup>3</sup> Ralfe, Diseases of the Kidney, 1885, p. 175.

sponding with considerable diuresis and generally with a diminution of the amount of albumin in the urine. It is important that this association of signs be attended to, for there is a disappearance of dropsy unassociated with lessening of the albumin, which is prone to indicate a very chronic malady and one that is little likely to end in recovery. Moreover, dropsy is not by any means always present: cases sometimes run their course from first to last without any, and this may be so in such as end fatally as well as in those that do well. It sometimes happens, too, that after it has disappeared and the albumin also, a slight relapse in this respect will take place and the child again become puffy about the face or the ankles. This is, of course, quite a common thing in the chronic cases and with the albumin persistent.

*Heart and Arteries.*—Another very common departure from health is more or less disturbance of the heart's action and of the pulse. I have already described the latter as intermittent, but perhaps it less seldom misses a pulsation at the wrist than that an occasional beat falls short of its proper volume and power; while, if listening to the heart-sounds, perhaps once in eight or ten beats there is a one-beat stagger or shuffle. This symptom is, I think, more conspicuous in adults than in children, and is generally associated with more or less of the well-known pulmonary distress or asthma,—air-hunger, as it has been called,—a symptom of renal disease almost absent in childhood, perhaps because it belongs more to chronic than to acute disease, and chiefly, of course, to the granular form of kidney. The heart is often laboring in its action, its sounds thick, and its impulse displaced outward.

In childhood the pulse of renal disease is usually an accelerated one; it seldom to the finger conveys the idea of hardness or tension so characteristic in adults, and only occasionally have I seen anything of the kind in the sphygmographic tracing.

These points are all of importance, because Friedländer, Silbermann, the writer, and others have found the left ventricle dilated in certain cases of death from acute nephritis, and I have contended for this condition coming on somewhat rapidly and causing death suddenly, and somewhat unexpectedly if we are not prepared for such an occurrence. It has been argued with much probability that the dilatation of the ventricle is the result of increase of tension in the systemic system, the heart, becoming fatigued by the stress of work, acting irregularly, and then dilating. But Hensch has combated this suggestion, and reverts to the theory of uræmia or of some cause at present unknown. His objections are three:

1st. That evidence of arterial tension often fails. This I at once admit, but it would be strange if it did not do so, for, inasmuch as increase of tension must be due in part to the requisite vigor of the cardiac muscle, when this fails and the ventricle dilates rapidly so will the evidence of tension disappear. It is to this very fact that I attribute the *common* failure of this evidence in children, and I say that rapid dilatation of the heart is a special risk in early life.

2d. The heart is said to be found sometimes dilated at the autopsy when the pulse has been quite regular all through. This, again, must, I think, be admitted, and may even be regarded as a difficulty; but, at the same time, we know as a fact that this is not uncommon in adult life, in chronic disease, and in conditions of obviously increased tension; and one can therefore only suppose—what is not, indeed, unlikely—that the heart may slowly dilate under the influence of the tension while the muscle still is enabled to fulfil its functions adequately.

3d. It is said that, inasmuch as most cases recover, it is necessary to suppose a frequent recovery from dilatation of the ventricle, and that this appears but little likely. On the contrary, I am convinced of the reality of the frequency of recovery from dilatations of this sort. There is many a case of renal disease in which under the influence of disease the impulse goes outward and the heart-sounds are laboring and unnatural, in which the natural conditions are restored as the malady subsides. The cases of anæmia could be numbered by the score in which the same physical signs, coupled with subjective symptoms of disturbed cardiac action, all combine to indicate dilatation of the ventricle, and all completely subside under the influence of rest and the administration of iron; and I take it that one of the most vital points in medicine to insist upon is this power of the heart to recover from temporary dilatation.

*Skin.*—In adults, as is well known, the skin is usually dry and perspiration is difficult to provoke, even in children this is certainly nothing like so regular, and in many cases even of general anasarca it is either naturally active or at any rate is readily excited to sweating.

*Retina.*—I have only once or twice seen albuminuric retinitis in childhood, and this in somewhat chronic and fatal cases.

But there are tableaux of symptoms other than this. Thus, a child is taken suddenly, after scarlatina in the particular case that now presents itself to me, with hæmaturia. It is not at any time extreme, and disappears within three or four days, but the urine becomes more and more scanty and ends with complete suppression. Except for this history there is nothing to indicate the malady with which we are dealing. The child lies in bed without a trace of dropsy, and at the end of seven or eight days dies of sheer asthenia. I recall a very similar case in a youth of sixteen or seventeen who could give no cause for his illness. The picture is noteworthy because of the complete absence of the so-called uræmic symptoms, in this corresponding to a class of cases in adults, now well known, chiefly from the writings of Sir William Roberts, due to mechanical arrest of the outflow of urine, in which death also comes by asthenia. I should say that in both the cases above alluded to, the microscopical examination of the kidney revealed an unusual degree of glomerular nephritis and very little else.

And yet another scene floats before me, perhaps more common, in which there is the same absence of dropsy but albuminuria and anæmia are coupled together, yet so little are any other symptoms of renal disease

present that one is tempted to ask which is the primary disease. Of the minute changes in the kidney in such cases as these I am less sure. The naked-eye appearances I have already dilated upon as those of pallor, or the fatty kidney. But the minute changes have sometimes been so little pronounced as to give color to the suggestion that some forms of albuminuria are of hæmatogenous origin. Here is a case that illustrates some of the difficulties of this class. A child of eight years was under treatment for headache, drowsiness, and obstinate vomiting. The illness had commenced by convulsions, without pyrexia. The urine, said to have been normal at one examination at the onset, had for several days contained a large quantity of albumin and was pale and watery-looking. Latterly there had been some bleeding from the gums and the face had become puffy, but this was hardly appreciable to a stranger, and there was no trace of dropsy elsewhere. There was excessive anæmia, and the urine was full of albumin. These and the vomiting were the only symptoms, and it seemed possible that the albuminuria might have some obscure cause in the anæmia, or even some other blood-condition, such as diphtheria may supply us with an example of. The child died at the end of six weeks, the vomiting having continued, and intermittent suppression closing the scene. The kidneys were the only organs diseased: they were of natural size. The capsules were adherent; the surface slightly dimpled; in color pale fawn, and mottled. They had all the appearance of extensive parenchymatous nephritis of some weeks' if not months' standing, and by the microscope the excess of fibre between the tubes, the thickening of the vessels, and the wasted tubes, all combined to show the existence of a rather advanced interstitial change.

Then, too, although the *average* of disease in childhood is more or less acute, occasionally it is the very opposite. And parenchymatous nephritis is sometimes a disease of onset so insidious that it cannot be said to own any perceptible or characteristic beginning. In that case an insatiable thirst may herald the disease when it would otherwise be overlooked or pass for something else,—“diabetes insipidus,” for example. The two following cases illustrate both these points,—that the disease may be very insidious, and that for the diagnosis of such cases thirst may be the guiding light. This symptom is also mentioned later on as existing in a case of granular kidney.

A boy of six years was brought to me with the following perplexing history. He was brought up by hand on milk and oatmeal; when the bottle was given up he developed an intense thirst, which had never subsided, and for which he would drink as much as a quart of water during the night, and in times past even more than this. In early life he would have an occasional attack of sickness after excitement, but was considered healthy until the age of three years, when he had a sudden and severe attack of fever and vomiting, thought by one medical man to be a cerebral inflammation, by another to be of gastric origin. After his recovery he suffered from bad night-terrors, and ever since has been subject to severe

attacks of tetany and periodic attacks of vomiting. His urine had been examined from time to time, and it was always of low specific gravity; it sometimes contained albumin, sometimes not, and never more than one-twenty-second part. He had not had scarlatina nor measles. I found him a wizened-looking child weighing thirty-one and a half pounds, with a dry skin and eczematous patches about the face. The parents evidently had great difficulty about his diet, but there were no indications of any disease, except that the urine had a specific gravity of 1005 and contained a good deal of albumin. There were no casts. There was no trace of dropsy. From that time until his death, about three months later, he was under the close supervision of Dr. Dring, from whom I learned that the albumin sometimes quite disappeared, the polyuria persisting until a short time before death. But the peculiarity of the case was that almost punctually once a month he had a relapse, the tetany reappearing, the urine becoming scanty and so full of albumin as to be nearly solid; the attack would then pass off, the albumin diminishing rapidly down to none, or a trace. He died in one of these attacks, comatose, and in a state of opisthotonus. At the autopsy, at which I was present, both kidneys were small and shrivelled, their capsules adherent, the surfaces pale and speckled with fatty products, the cortex much diminished in thickness, the pelves a little dilated. Their structure was much diseased; a large excess of fibre permeated and spoiled the cortex, and many of the Malpighian tufts were shrunken and in a state of hyaline degeneration. The vessels were thick, but this was not a remarkable feature of the case. The heart was large, flabby, and widely dilated. No disease of the other viscera or of the brain was found. The urine in the bladder was pale, and contained about a sixth of albumin and a few doubtful pieces of fatty casts.

Within a few weeks of the death of this child its cousin was brought because its symptoms resembled those of the other case. The history is as follows. A girl of six and a half years. The parents are healthy people. This is the fifth child of a family of six of whom one died a few weeks old of whooping-cough, and another (the third in the series) of atrophy and "diabetes" at the age of twenty-two months. The mother states this spontaneously, and adds that it both drank and passed large quantities of water, but that the urine never contained any sugar. An attempt was made under medical advice to curtail the fluid imbibed, but the child suffered so much from the thirst that it had to be relinquished.

The present patient was never a strong child, but nothing was noticed specially wrong until weaning. It was at that time that she began to suffer from intense thirst, which has continued ever since. Her sleep is much disturbed because of it. She has taken as much as three pints of water in the night and a similar quantity by day, and she is always wanting to drink. She has had attacks of sickness at times and intense headache with intolerance of light, and within the last three months she has had an attack of severe cramp in her legs (? tetany).

She is a wizened-looking child, with a dry skin and a patch of distended capillaries on each cheek. Her weight is only twenty-seven and a half pounds. Her tongue is clean, but red. There is no trace of anasarca, nor has there ever been. Her urine is very pale, has a specific gravity of 1004, and contains one-sixth of albumin. There was absolutely no deposit in the urine after long standing, and no casts could be found. The heart and blood-vessels were natural, and the retina was free from changes of any kind.

To these must be added the group of cases of nephritis in infancy in which, apart from the results of examination of the urine,—when, in all probability, casts as well as albumin will be found,—there are no recognizable symptoms. Holt writes,<sup>1</sup> “The symptoms, as a rule, are misleading, and tend to attract our attention to the brain or digestive system rather than to the kidneys.” In many of the cases collected by this writer, twenty-three in all, fever is mentioned, the pulse was rapid, the respiration peculiar, and the nervous symptoms prominent. As a good illustration of how difficult the diagnosis of nephritis in childhood may sometimes be, the following case may be quoted.

A little girl of eight years was admitted into the Evelina Hospital under my care on one day, and died the next. Her previous history was that she had always been easily upset by food, and would then be sick and feverish, with abdominal pain, for a few days. One of these attacks, apparently, commenced seven days before her death, when she was quite well. She felt sick, had stomach-ache, and was feverish. She afterwards vomited repeatedly, and when admitted on the sixth day she was in a very alarming condition. She was pale, drowsy, ashy in appearance, with subnormal temperature, cold extremities, and imperceptible pulse. The heart-sounds were rapid and irregular. She passed an ounce of urine soon after admission, of 1030 specific gravity and containing casts and one-tenth albumin. She passed no urine for many hours, and just before her death became convulsed. The heart was large and the left ventricle dilated. The kidneys had the appearance of chronic congestion and felt hard, the capsules perhaps a little adherent. The microscopical changes were not pronounced; the vessels of the cortex were full of blood and in many of the tubes were fibrinous casts.

**Course and Duration.**—This will depend upon several circumstances. Given an average case of scarlatinal nephritis, the attack usually supervenes in the second or third week. The urine improves in color and in quantity after a few days, and in a fortnight or so the amount of albumin will have considerably decreased. The albumin may continue to diminish, and may disappear in from three to five weeks, or it may linger on, with mild relapses and ultimate cessation, for many weeks, and sometimes for months.

But I am disposed to think that the age of the child enters into the question. I have already said that the nephritis of childhood is more likely

---

<sup>1</sup> Primary Nephritis of Infancy, Archives of Pediatrics, 1887, p. 114.

to do well than that of adults, and this applies probably without limitation from the one extreme of life to the other. Then, from what I have seen, the nephritis of infancy is likely to run a rapid course, the dropsy to disappear, and the urine to regain a natural state almost in a few weeks. The ground for such an opinion is admittedly not a very extensive one. It may be that the nephritis of infancy is largely unrecognized, and that in this part of its history come the fatal cases to swell the list. Dr. Emmett Holt<sup>1</sup> has published a paper on the primary nephritis of infancy, which rather confirms this view of the case; for, in the first place, the facts therein recorded agree with others of Sée and Ashby, in showing that nephritis may be wholly latent and pass unrecognized unless the urine be examined in all cases of illness; and, secondly, the deaths amounted to eleven out of nineteen. Dr. Holt adds, however, that this mortality must not be supposed to represent the real death-rate from these forms of nephritis, the truth, no doubt, being that the great proportion of the milder cases escape notice altogether. The few cases I have seen in infancy associated with dropsy have done well. I have published one such case.<sup>2</sup>

Another occasional peculiarity of nephritis in childhood is a somewhat tedious course for many weeks of albuminuria and anasarca, and then a rapid, not to say sudden, disappearance of both, and recovery, when one had almost begun to be despondent. I give a short note of two such cases.

A boy of three and one-half years was admitted to the Evelina Hospital on October 4, 1886. Some four months before his admission he had an attack of fever: he was hot and thirsty, but had no rash out, and about this time it was also noticed that his urine was scanty and dark ale-colored. It had occasionally been of the same color since. Swelling of the legs, etc., had come on gradually since then, and for five weeks before his admission he had been in bed.

He was in a condition of extensive anasarca, no part of the body being free. The impulse of the heart was in the fifth space, just internal to the nipple-line, and the action was rather irregular, there being a half-pause every third or fourth beat. The sounds were flappy and the second reduplicated over the pulmonary area. The urine had a specific gravity of 1010, and contained one-third albumin, with granular and hyaline casts. From October 4 to June 10 he remained much the same, and on the latter date the albumin still measured as much as a sixth after settlement. It had averaged throughout from a third to a sixth, but there had been several temporary drops. To this it must be added that the child was hardly to be called ill for the greater part of the time, although in this matter, too, he varied, being sometimes very poorly for a day or two and then causing some anxiety. Towards the end of February the dropsy began to diminish, and soon all but disappeared. In April the specific gravity of the urine rose

---

<sup>1</sup> Archives of Pediatrics, 1887, vol. iv.

<sup>2</sup> Student's Guide to the Diseases of Children, 3d ed. 1888, p. 425.



from 1010 or 1015 to 1025-1030; it was habitually scanty in quantity, hardly ever being more than seven or eight ounces. On June 10 the albumin was at one-sixth, next day it had gone to one-twenty-fourth, and within four or five days there was none. A trace reappeared afterwards, and this remained on his discharge six weeks later. He was treated almost throughout by the wet pack twice a day. It answered well, and he sweated profusely. A subcutaneous injection of one-twelfth of a grain of pilocarpine was given occasionally; citrate of potassium and digitalis for a time; and after some few weeks iron continuously.

The second case was also a boy, aged four and a half years. He had been ill with dropsy only a week, and for the same time the urine had been only a few ounces in the twenty-four hours. He was very short-breathed, with extensive general anasarca; the urine 1026, full of albumin, and containing large numbers of hyaline and finely-granular casts. The heart-sounds were thick and long, and the second accentuated. He was treated by the wet pack and by citrate of potassium in seven-grain doses given every four hours, his diet being restricted to milk and water, jelly, biscuit, and bread and butter. The albumin decreased somewhat under these measures, but it remained in fair quantity for four months, the specific gravity being from 1012 to 1015, and the dropsy disappeared, but the health of the child remained at a very low ebb. At the end of this time the specific gravity of the urine rose suddenly to 1020, and the albumin disappeared altogether within a few days, and he has since then remained well.

It is impossible to reflect upon such a history as is here given, without being struck with the fact that it does not square with any idea of inflammation present to the morbid anatomist, and that it much better accords with the supposition of some circulatory stasis that has been suddenly unlocked, or of some hæmatogenous manner of production of albumin in the urine of which as yet we know nothing. Of course there are many conditions under which albumin, even in quantity, comes and goes. But that it should be present for some weeks and even months, and then suddenly disappear, is not common, although diphtheria may supply some approximation to this requirement. I remember, also, to have once seen something like it in a severe case of typhoid fever, in which the albumin remained in quantity for many days after convalescence, giving rise to some anxiety, and then vanished like a dream. For the rest, one can occasionally trace an acute nephritis, sometimes with dropsy, when it will all disappear, sometimes without it, in which case the albumin, although for a time it diminishes, never disappears, in which, some years after, a granular kidney is found. I have seen one or two such cases. This event appears, however, to be more likely, as I shall presently relate, when there has been no dropsy, or when the dropsy has been but slight and transient. It is certainly not common in childhood to find, as in adults, the anasarca remaining for some time and then disappearing while the albumin remains, a mixed or, as some would say, a contracted white kidney being found after death.

In children, as in adults, the dropsy may be very persistent and the patient die of a large white kidney after many weeks or months. Cases of this sort must be present to the minds of all my readers. Several of the kind are given by Dickinson,<sup>1</sup> and others may be found in the admirable abstract of medical and surgical cases emanating from the General Hospital for Sick Children at Pendlebury. As I have already said, they have not been the common cases in my experience.

**Diagnosis.**—When all the symptoms are present by which the disease is known in adult life, no difficulty can present itself that requires mention. The points to bear in mind are that most of them may be absent, and that the younger the child the more likely is this to be the case. Not only so, but other symptoms may exist that seem to point in quite other directions. One child may suffer from sharp fever; another may be drowsy or convulsed, or may vomit; another may be purged and collapsed. Over and above the examination of the urine as a never-to-be-neglected part of a first examination in every case, it is probable that scantiness of the urine is the most constant symptom pointing to defective renal activity in these cases.

But it must not be forgotten that sometimes in albuminuria the dominant feature, as already told, may be that of anæmia; that in no small number there is no dropsy or at most only an indefinite puffiness; and that it happens occasionally that a child is said to have died suddenly without any pronounced symptoms of any sort, and the left ventricle of the heart is found after death to be dilated.

Two other important considerations require notice here. In the first place, dropsy may be present, and acute nephritis, it may be presumed, also, without the existence of albumin in the urine. Secondly, and far more commonly, an albuminuria exists from which it would be a mistake to postulate the existence of a nephritis.

I take this first. I am of opinion that, while the presence of albumin in the urine in small quantity at one or two examinations may mean anything or nothing, the persistence of this symptom for any length of time without definite cause—such, for instance, as some passive pulmonary congestion or local scrofulous disease—is generally due to nephritis. I am familiar with the long existence of albuminuria without signs of ill health, but I am indisposed to admit that the existence of nephritis is thereby negatived. In five years past I have been on the watch for cases of the so-called functional albuminuria now so often spoken of, and, as the result of a very large number of examinations, the only conclusion I can come to is that it must be of great rarity. I do not doubt that it may exist occasionally; nevertheless, in my experience any albuminuria that is present again and again in the urine of any child or adult is as conformable to the hypothesis of the existence of nephritis as it is to that of functional disease. The

---

<sup>1</sup> On Renal and Urinary Affections, vol. ii., Albuminuria, 2d ed., 1877.

symptoms of renal disease vary as the individual almost, and average health, if not common, is by no means unknown, and thus it is not at all safe to assume from the mere absence of symptoms that disease is absent. For example take the following case.

A youth of sixteen years had scarlatina when a child of seven. It was a mild attack and no dropsy followed, but within two or three months albumin was found in his urine, and has never since been absent whenever it has been examined, and that has been frequently, and always by observers of the first reputation. At one time he was kept for six weeks on a milk diet without any influence on the albuminuria, and it still remains in quantity. He has never had any symptoms that could be attributed to renal disease, and seldom any of ill health. His urine has a specific gravity of 1022, containing albumin in quantity, with hyaline casts. His heart and arteries are quite natural.

Here, then, is a boy who has had albuminuria for nine years, remaining still in perfect health; yet can it be doubted, with the history before us, that he is the subject of a chronic nephritis, or that in the end he will succumb to a granular kidney? Nor is the existence of health amid stealthy disease unusual: its parallel may be seen in many another pathological process. There is pulmonary phthisis, which often progresses with intervals of recovered health. There is mitral stenosis, which exists for years before it becomes evident by loss of health. There is the kidney itself in adult life, which may often be known to be on the way to a granular state years before the organ becomes so inadequate as to pull up the patient. This principle of "compensation," as it is called, may be traced in all diseases, more or less, and in all is sometimes so complete for the time as to obliterate the evidences of disease. But the disease is there all the same. I will only add that, important as are these reflections as regards diagnosis, they are hardly less so with respect to prognosis and treatment.

Dropsy without albuminuria in any extreme degree is rare, but in slight degree it is probably not uncommon. Dickinson alludes to it, Henoch has notes of half a dozen such cases, and Hillier, Sée, Bartel, Duckworth, and the author all make mention of it as a condition with which they are well acquainted, or publish cases. Thomas<sup>1</sup> and Philipp (quoted by Henoch) have seen epidemics of this character. It is an open question whether this condition is or is not due to nephritis, but the more general opinion seems to be that it is so, because in some cases casts have been found in the urine; and in most, a very interesting observation in relation to the pathology of the dropsy, the urine has been remarkably scanty, in some amounting to temporary suppression. In Dr. Duckworth's case<sup>2</sup> the diminution of the urine was quite remarkable, and so also in one that occurred to me.<sup>3</sup> Such cases as I have seen have done well, but it is not always so. Henoch al-

<sup>1</sup> Ziemssen's Cyclopædia, vol. ii. p. 259.

<sup>2</sup> St. Bartholomew's Hosp. Rep., vol. xix., 1883.

<sup>3</sup> Guy's Hosp. Rep., Series III., vol xxvii., 1883-84, p. 198.

ludes to others in which the albumin, absent during the greater part of the illness, appears to some extent before death, and he quotes the statement of Litten<sup>1</sup> that there is a very grave form of hemorrhagic nephritis which is only revealed during life by some œdema of the face and hyaline casts in the urine. In mentioning authorities I must not omit the recent edition of Rilliet and Barthez, in which is given (tome ii. p. 694) a summary of these varied relations of the dropsy and albuminuria of Bright's disease, which is altogether admirable and quite accords with my own experience. It is indeed so much to the point that, at the risk of repetition, I give it in abstract. 1. Albuminuria may appear only after the onset of the anasarca. 2. Albuminuria may precede the dropsy. 3. Anasarca may return, in certain cases of relapse, without the reappearance of albumin. 4. Persistence of albuminuria is no impediment to variations in the intensity of the anasarca. 5. The albumin may disappear and the dropsy persist. 6. The anasarca may be wanting throughout the entire course of the malady.

**Complications.**—Most of these have already been described in dealing with the symptoms. They come about in various ways. At one time it is the nervous system that seems particularly obnoxious to the defective elimination, when we may have to deal with sudden, violent, and repeated eclampsia, or obstinate vomiting. Convulsions are usually preceded by a diminution of the quantity of urine passed. They vary much in intensity, from a slight muscular twitching of some part of the face or extremities to a general epileptiform discharge affecting the whole body. There may be only one attack, or one may be rapidly succeeded by others again and again, when the condition is one of much danger.

At another time it is the tendency to œdema of the tissues and cavities that threatens. The anasarca may be so extreme that the skin will even give way, and large bladders form covered only by a delicate pellicle of cuticle. The skin is then very liable to a low form of inflammation or a wandering erythema, and this forms a dangerous addition to the already existing disease. One of the commonest and, on the whole, least ominous complications in this direction is ascites of moderate degree; but common, also, are hydrothorax and œdema of the lung, and both are dangerous, though probably more because they are indications of the severity of the disease than as an immediate cause of death in themselves. Hydrothorax is usually a slow formation, a part of the gradual water-logging. œdema of the lung is often developed rapidly, and assumes the part of an acute bronchitis, as regards its physical signs, but the face is pallid, the respiration is much distressed, and the aspect of the patient betokens impending dissolution. Besides this, broncho-pneumonia is not uncommon: Drs. Ashby and Hutton, of Manchester, give notes of several such cases, in the annual abstracts of the Pendlebury Hospital for Sick Children.

Of others it may be said that they have no special peculiarity in chil

<sup>1</sup> Charité-Annalen, VII. Jahrg., p. 162.

dren, and are, I think, indeed, less often seen. Yet at any age there is a tendency to inflammation of the serous surfaces, and, as regards the peritoneum, to a latent but rapidly-developing and lethal suppurative peritonitis. Happily, it cannot be said to be at all common. Barthez and Sanné lay stress upon diarrhœa as an occasional cause of rapid death, which may come on either spontaneously or be provoked by the purgatives oftentimes essential to the treatment of the disease.

One other complication, hemiplegia, may be mentioned. It is rare, and for the reason that it is probably dependent on conditions other than those that lead to it in adult life. It is sometimes part of the phenomena of an attack of convulsions, and may persist afterwards, when it is possibly due to some cortical hemorrhage, thrombosis in the sinuses, or what not; in others, and more commonly, it is probably due to an embolus, and is dependent on cardiac changes secondary to the renal, and in all likelihood to a scarlatina that has preceded it. In this case the embolus may be washed from some inflamed valve or detached from some pouch of the ventricle, the clot having formed there during the time of failure of cardiac energy either from the fever or from the fatigue produced by the renal disease.

**Prognosis.**—It is very difficult to say anything that is really useful, the composite of symptoms varies so much for the individual. Barthez and Sanné give a loss all round of one in three. But it is very difficult to get at a reliable conclusion; probably some large and carefully-drawn statistics from general practice would best meet the difficulty, and it may be doubted whether from such a source the death-rate would be as high as this.

The elements for a prognosis in any particular case have already been indicated. In a case that is to do well the symptoms of the disease should show progressive amelioration, the scanty urine should become copious, the albumin should diminish steadily, and complications should be absent. The disappearance of the dropsy unaccompanied by lessening of the albumin at the time or shortly after is a bad sign rather than a good one. The occasional reappearance of a little blood in the urine, provided that the case is in other respects improving, is not of itself of any moment. The reappearance of lithates in an acute case is a good sign; and so also is the absence of disturbance of the general health. Bad signs, as a rule, are the persistence of dropsy and of albumin in quantity, persistent scantiness of urine, much pallor, albumin in quantity and dropsy little or none, the existence of albuminuric retinitis, the occurrence of erythematous eruptions on the skin. In adults we are accustomed to look to the pulse for certain indications of renal disease,—the hard persistent pulse, so characteristic and so well known,—and Dr. Broadbent has pointed out, with his usual acumen, that when these are wanting the prognosis is a grave one. I am sure that this is so: I have seen several such. Yet in children, as I have already said, the pulse-symptoms are not obtrusive, and are difficult to gauge, and more information will be gained by attending carefully to the sounds of the heart and to the position of the impulse at the surface of the

chest. If the impulse goes outward and the heart-sounds become weakened, slow, and laboring, it is quite possible that there may be some sudden termination of the case; so that the friends might be prepared.

**Treatment.**—There are certain well-established rules for the management of nephritis that are common to all ages of life. These are that the surface of the body be kept in an equable temperature, that the bowels be kept freely open, and that the diet be mostly a fluid and weakly nitrogenous one. The object of these various measures is not far to seek. The skin should be kept in a warm atmosphere,—that is, in bed,—to keep it active and thus to prevent, as far as possible, the correlation between skin and kidney so important to a healthy organism, but likely to be harmful to a damaged viscus by goading it to spasmodic activity.

The patient is therefore kept in bed, between blankets. The skin is made to act freely by the free administration of liquid foods and water, and diaphoresis is aided by medicines such as acetate of ammonium and the pulvis ipecacuanhæ comp. Additional and powerful means of promoting perspiration are pilocarpine and the wet pack. All observers seem to agree that the former is a dangerous remedy in children, as it is often productive of vomiting and sometimes of alarming collapse. I have given it as a hypodermic injection in doses varying from one-fifteenth to one-twelfth of a grain to children of from four to eight or ten years, and it seldom fails to induce sweating, but I cannot say that I have seen much certain benefit from its use. Demme<sup>1</sup> has given five milligrammes to children under two years of age, from seven to ten milligrammes to those from two to six years, and as much as twenty-five to those above six years, but I would not recommend the larger dose. One injection a day is usually sufficient. It can also be given by the mouth, and perhaps better so to children, in doses of from one-eighth to one-fourth of a grain, either in tablet or in syrup and water; but in any case it is best to use it with caution and to feel one's way.<sup>2</sup>

I much prefer the wet pack. A thin blanket is wrung out of hot water, and the child, divested of all its clothing, is wrapped in it from chin to feet; then a dry blanket is wrapped round it and loosely covered with a mackintosh. After an hour or so the wet pack is removed, and the child swathed in a dry blanket. This is a powerful means of producing a free action of the skin, and with care I do not know that it is ever harmful, but the body-temperature must be watched meanwhile, and the pack should not be continued for any excessive length of time. At the Evelina Hospital for Children we at one time applied a continuous pack in several cases, but it was productive more than once of a sudden rise of temperature to a rather alarming height, and in another case, although the nephritis was cured, an acute general dermatitis exfoliativa was caused which was many weeks before it

<sup>1</sup> Jahrbuch für Kinderheilkunde, xvi. 369.

<sup>2</sup> See also Henoch, *op. cit.*, for a still more doubtful advocacy of this drug.

got well. Dr. Carpenter, the resident medical officer at the Evelina Hospital, has published these cases in the *Practitioner* (1888).

In addition to these measures there are warm baths and vapor baths, which, provided that chills are avoided on getting in and out of the bath, are some of the least harmful means of relieving the kidney; yet even measures so simple as these are not without drawbacks if used indiscriminately. Hæmoch has occasionally seen a warm bath followed by a fresh accession of hæmaturia after each bath. Dr. Dickinson also speaks in words of warning. He says that much mischief has probably been done by purging and sweating, although in their proper sphere they are invaluable. Barthez and Sanné consider baths most suitable for chronic conditions and when the respiratory tract is healthy. If the disease is acute and the lungs are implicated ever so little, they are dangerous. They have seen sudden œdema of the lungs and death follow their employment several times; and, although I cannot say that such has been my own experience, I think the statement is well worth attentive consideration in conjunction with what has been said regarding the continuous pack.

Alkalinity of urine is thought by many to favor the return of the kidney to its natural state, and citrate of potassium in requisite doses may be given with that object.

The question of diuretics has been much discussed, and if by diuretics be meant all such remedies as are supposed to act directly upon the kidney, such as squill and broom, I can only say that after many trials I have long discarded them as quite inefficacious under the circumstances in which they are required to act. The only diuretics of any value are digitalis (and possibly other remedies of that class, such, for example, as strophanthus), salts such as citrate of potassium and benzoate of sodium, and water. These are all of value,—the cardiac tonics probably by their action on the circulatory system, the water by diluting the blood and making it less obnoxious to the tissues, and the salts by favoring the conversion of the urates into other and less irritating products. Caffeine, too, may receive favorable mention for occasional cases. Its value is probably due to its action on the circulatory and nervous systems rather than to any local action on the renal cells, although in combination with benzoate of sodium and ammonium it is unquestionably at times a useful and potent diuretic.

There are no drugs that will directly lessen the quantity of albumin that is passed, but I doubt whether the drain of albumin is often sufficient to do any serious harm: the importance of the quantity is chiefly in its being an index of the state of the kidney. If, however, after three or four weeks the albumin remain in large quantity, and blood continues to reappear from time to time, or the pallor is considerable, iron sometimes does much good. I give it sometimes as the tincture of the perchloride, sometimes as the acetate,—a preparation that is usually well borne. Hæmoch speaks well of tannic acid and of ergotine. The former I have often made use of, the latter sometimes, but I cannot say that I have seen any benefit from either.

Failing with iron in the later stage, I think that maltine and cod-liver oil are sometimes of use. There must be something very peculiar in the change in nutrition indicated by the fatty changes of chronic parenchymatous nephritis, and when it goes, as is often the case, with extreme pallor it has often occurred to me to treat the anemia rather than the renal inflammation. But it is, I think, certain that a strong meat diet makes matters worse, and where iron tonics fail to mend matters much it becomes a necessity to apply to those foods which will aid us without overtaxing the damaged viscera. I have seen cases where it seemed that the administration of cod-liver oil and maltine, once or twice even of brandy, was the starting-point of recovery, and for exceptional cases I am not prepared to prohibit any article of diet, even meat or alcoholic stimulants.

To sum up, then, in a simple case the child is at once put to bed between blankets; its diet is reduced to milk food, varied as much as possible by the introduction of vegetables, ripe fruits, cream, etc., with the free administration of soft water; a daily warm bath is given,—if necessary, a wet pack or vapor bath; the bowels are kept freely open by an occasional purge, and the acetate of ammonium and perhaps a little pulvis ipecacuanhæ comp. are administered internally.

If the urine becomes scanty or convulsions threaten, the wet pack is repeated at intervals of four or six hours, a large poultice is applied to the loins, and dry or even wet cupping may sometimes be resorted to with advantage.

The various complications may be taken *seriatim*.

*Convulsions*.—The child should at once be divested of all clothes and placed in a wet pack, or, as some may prefer, the loins may be dry-cupped freely, and a large poultice applied over them and changed every three hours. The wet pack is to be used concurrently with these measures.

The bowels are to be freely opened by two or three grains of calomel, and, after the action, twenty grains of bromide of potassium may be given as enema, or eight or ten grains by the mouth if the child can swallow. In the majority of cases these measures will prove sufficient: the patient slowly comes round from the drowsy state following the fit, the urine is secreted more copiously, and then the measures already described may be resumed. But in the more severe cases, where one fit follows another, or other of the lesser convulsive movements seem to threaten, the vexed question of venesection must be considered. I cannot speak from experience, for I have never, that I remember, bled in such a case; but it is for such cases that most writers on diseases of children advise that either cupping to the loins or leeches to the mastoid process should be applied. For my own part, I should still prefer an ice-bag to the head, and the administration of chloroform and bromide of potassium and hydrate of chloral, either by the mouth or by the rectum. Dr. Barr speaks strongly in favor of benzoate of ammonium in full doses for preventing a recurrence of the fit, and, although I do not remember to have ever made use of it in precisely



these cases, I am so impressed with the value of the benzoate of sodium for aiding elimination by the kidneys in renal disease, as I have already said, that I certainly think it might prove useful here.

*Vomiting* may be present at the onset of the disease, when it probably will not call for special treatment, or it may indicate a grave amount of mischief, and will be best combated by measures already detailed which aim at procuring depuration of the juices by viscera other than those diseased. Should local remedies seem advisable, half-hourly drop-doses of tincture of iodine in a teaspoonful of water may be tried, or the old-fashioned but effective bismuth with hydrocyanic acid and bicarbonate of sodium. Nitroglycerin is sometimes useful in adults and might possibly be so also in children. Much, too, may be done with diet. Skimmed milk or whey, iced, will often be retained when other things are vomited. A little iced champagne, too, is a seductive to the stomach well worth a trial.

*Diarrhœa* must be treated by ordinary measures.

*Dropsies* of the serous cavities may require paracentesis for the relief of immediate symptoms, but it is not often so, particularly as regards hydrothorax. It is far more common to have to tap the abdomen, sometimes because of the amount of fluid in the abdominal cavity, and sometimes with the object of inducing, by the removal of pressure, a better excretion of water from the kidney. I always make use of a very fine canula, such as that called a Southey's tube, but made longer to allow of penetration of any additional thickness of the abdominal wall. A tube of this kind may be left in the peritoneum for ten or twelve hours without any risk and with little discomfort. It will usually become blocked with a little lymph by the end of this time or probably before, but ten or fifteen pints may be withdrawn in this way, to the great relief of the patient. The chest must be aspirated if any operation is necessary; withdrawal of the fluid by other means is a remedy of the last resort.

*Anasarca* must for the most part be treated also by occasional free purgation and by the vapor bath or other sudorific. In extreme cases I prefer simple acupuncture to the use of Southey's tubes, as less worrying to the child.

But I have no doubt of the utility of digitalis and strophanthus, and I have certainly seen good results also from caffeine or its combination with benzoate of sodium. Some advise that the fluids imbibed should be limited in these cases, arguing, with great appearance of probability, that the more fluid taken in, the more is the anasarca likely to be increased. But, so far as I have been able to judge from actual cases, I do not think this objection to free imbibition well founded. On the contrary, I have occasionally carried out this suggestion, and I have invariably found that the albumin has increased in amount and the patient has been worse. The treatment of the anasarca is indeed in some cases a very anxious question: do all we can,—drugs, baths, puncturing the legs,—nothing seems to dissipate or even to arrest it, and this is particularly so in adults—I cannot say it is in children

—where the chronic nephritis exists without the usual concomitant of high arterial tension.

*Suppression of urine* must be treated in much the same way as an attack of convulsions, omitting, of course, such remedies as are aimed directly at the arrest of the convulsive movements. A brisk aperient is given, the loins are freely dry-cupped and then poulticed, and the body is either wet-packed or treated to a vapor bath. Acetate of ammonium and citrate of potassium are given freely by the mouth, and plenty of watery drinks, such as barley-water, whey, soda-water, and lemonade.

*Pulmonary œdema* is a very dangerous symptom, and it is to be prevented rather than treated. When it has set in, a dose of compound jalap powder or of scammony powder should be given at once, and small doses of digitalis mixture, digitalin, or strophanthus given at frequent intervals. Brandy or champagne will also, in all probability, be required.

*Hæmaturia* seldom calls for treatment. Even when it is profuse it usually ceases within a short time; and when it appears and reappears merely to the extent of tingeing the urine it is of no moment as a hemorrhage. But, if necessary, hamamelis, ergotine, or tannic acid may be given.

The *dilated heart* of renal disease is usually a concern of the left ventricle, but I may say, in passing, that I have occasionally met with it on the right side, and even on the right side alone, when I have been obliged to assume that the arterial spasm in some cases is more pulmonary than systemic. But it is mostly the left ventricle that suffers, and it is to the clinical evidence of this that our attention should be directed with the view of preventive or other treatment. The evidences are twofold. In the first place, some indications may be gathered from the character of the heart-sounds and the features of the muscular action. These have already been described. The irregular or halting action, and the impression of labor conveyed by the length, want of sharpness, or shuffling quality of the systole, indicate unmistakably to the attentive ear that the ventricle finds a difficulty in overcoming its work, and that it requires such aid as can be afforded it. In the next place, in many cases other evidence can be obtained by a careful scrutiny of the position of the impulse on the chest-wall. It is therefore imperative in all cases of acute renal disease that the heart should be examined daily if possible, or at any rate at frequent intervals, and if there be any evidence of heart-failure it may be obviated or lessened by appropriate measures. These are little different from those that have already been mentioned, but they will vary somewhat with the case, one measure proving more useful in one case and another in another. Thus, a free hydragogue cathartic is one of the most useful methods of relieving a jaded heart. With it, it may be advisable to give a little alcohol. The wet pack or vapor bath may do something; alkaline diuretics also. But, as a general rule, digitalin, digitalis, strophanthus, and caffeine are the remedies most useful. It is my belief that by carefully watching the heart, and giving digitalis or one of the other remedies when the first symptoms of

heart-failure appear, a dangerous crisis may in many cases be passed over. I usually give the tincture of digitalis in four- or five-minim doses every three or four hours, continue it for a day or two, and then leave it off for a day or two and take to it again if necessary. But small doses of digitalin, the one-hundred-and-twentieth of a grain, may be given frequently instead; strophanthus also in two- to five-minim doses, or caffeine in doses of one or two grains. The latter I usually combine with benzoate of sodium; this forms a solution in water which can be sweetened or flavored as necessary.

There are many other remedies that might prove of service occasionally. Thus, sparteine sulphate is recommended by some as a good heart- tonic. It may be given, one-fourth grain for a dose, three or four times daily, either as a granule or in solution. Paraldehyde, of unquestionable service in the laboring heart of old renal disease in adults, might be of service here. Five or ten minims may be given in almond mixture or with a little rectified spirits, tincture of orange, and water, either occasionally, or regularly two or three times a day; and, if time serve, strychnine, by subcutaneous injection, in drop doses of one-hundredth of a grain, is one of the most valuable cardiac tonics that we possess.

Of the dropsy that is unaccompanied by albuminuria it is hardly necessary to speak, but this much may be said, that the few such cases which I have seen have all been readily amenable to rest in bed, the wet pack or vapor baths, and alkaline diuretics and diaphoretics. These measures, with perhaps the addition of a little digitalis, are the proper ones to adopt in such cases. For those who have once had a pronounced attack of renal inflammation it is advisable that they should in the future be more carefully preserved from chills and undue exposure than heretofore. I have seen several cases in which a history has been given of recurrent attacks of slight puffiness of feet or face in the course of several years, with intervening periods of what have been described by the patient or the parents as times of health. Hensch also states that he has several times known a chill, as from a bath in the sea, produce a fresh attack, and he considers the kidney a vulnerable organ after an attack of scarlatinal nephritis.

---

## CHRONIC BRIGHT'S DISEASE.

**Synonyme.**—The granular kidney.

I have in the early part of this article given reasons for confining the meaning of the term "chronic Bright's disease" in children to the granular kidney, and it will be unnecessary to say more now. Of two hundred and thirty cases of granular kidney examined in the post-mortem room of Guy's Hospital in the ten years from 1873 to 1882, there is no case under ten years, and only one, a female, under twenty. But this is, as I have said elsewhere, a matter of interpretation. Some would call all kidneys granular

which are small and irregular on their surface, but even with this liberal interpretation granular kidney is not and could not be a common disease in children. Any one who has ever given the smallest consideration to the physiology of child life and to the pathology of the granular kidney will admit this at once. The questions of most interest are, does it occur? and, if it does, what are its causes? and the interest of these lies chiefly in their throwing light upon the natural history of the disease in later life.

That it does occur can at once be proved by cases. Records of many such are to be found scattered through the medical periodicals of recent date, and I give short notes of two, one not hitherto published, that have been kindly furnished to me by Dr. Henry Ashby, of Manchester.

Margaret B., aged ten, was admitted into a surgical ward of the Pendlebury Hospital for Sick Children for rickets and deformity of the legs. She had never been a strong child, and her legs had been crooked ever since she began to walk. Nothing peculiar had been noticed about her, except that during the last two years she had suffered a good deal from thirst, getting up usually once in the night to pass water. Recently she had had headaches, and labored breathing and coma on the last two or three days. She was a small girl, with deformed tibiae, and when in bed it was noticed that she had urgent dyspnoea. Respiration 26, pulse 110, temperature subnormal. She was much distressed and somewhat cyanosed. The examination of the chest revealed nothing abnormal: the cardiac beat was in the fifth space, half an inch inside the left nipple. Later in the evening the dyspnoea became more urgent and she more cyanosed, but without apparent cause. Respiration 36, pulse 120. The urine was passed under her, and none could be obtained for examination. During the night sharp diarrhoea came on, she became unconscious, moist râles appeared in the chest, and she died in a convulsion the day after her admission.

*Autopsy.*—Lungs gorged, but otherwise normal. Heart: left ventricle wall somewhat thickened. The kidneys were very small,—both almost exactly the same size,—one and eight-ninths inches in length, one and one-quarter inches broad. They were firm and pale; the capsule stripped with difficulty, tearing away pieces of the cortex; surface of the cortex granular; its section so wasted that hardly any remained, fatty-looking and mottled. The kidney, of which a slice is now before me, is a striking specimen of the active interstitial form of the disease. By this I mean that the disease is one of copious nuclear growth, and not one of mere fibrosis with atrophy. Thick irregular bands of highly-nucleated material spread from the cortex downward to the medulla, and within them are thickened and shrivelled capsules and wasted tubes. They have a basis of fibroid material, and show well-marked puckering or cicatrization. Outside them are tracts of comparatively healthy tubes.

The following case is from the published abstract.<sup>1</sup> It was that of a

<sup>1</sup> Abstract of some of the Medical and Surgical Cases treated at the General Hospital for Sick Children, Pendlebury, Manchester, 1883.

girl, aged eleven and three-fourths years. The history is imperfect, but the child had never had scarlatina, and her ailment dated back only two or three weeks. Three days before her admission her face began to swell and her breath became short. She was in much distress, with dilating anæmiasis. Pulse 120, weak; respiration 44; temperature 99.4° F. The resonance at the left base was impaired, and coarse râles were heard throughout both lungs. The first sound of the heart was weak, the second accentuated; no bruit; apex-beat in the fifth space outside the left nipple-line. The urine was pale, clear; no deposit; specific gravity 1015; one-half albumin. She was treated with jaborandi and packs, and passed gradually-increasing quantities of urine; but the quantity of albumin remained about the same (no casts were ever found), and the œdema also, and she gradually sank.

At the autopsy these points were noted. Much œdema of the subcutaneous tissues. Right lung: twenty ounces of fluid in the pleura, the lung semi-collapsed and œdematous. The left lung was gorged and œdematous. The heart weighed eight and three-fourths ounces. Right auricle wall very thin; right ventricle also, and cavity dilated. The left ventricle very thick; cavity slightly dilated. Peritoneum contained much fluid. Kidneys: right, two and one-fourth ounces in weight; left, three-fourths of an ounce. Right, small granular on the surface; capsule thickened and adherent; cortex very narrow, hardly existing in places; pale, infiltrated with urates; ureter and calyces dilated. Left, very small, merely a vestige; ureter and calyces dilated; very little kidney-substance; capsules adherent; surface granular; cortex and pyramid infiltrated with urates; both ureters dilated; no obstruction detected. Microscopically there was great increase of fibroid tissue between the tubules, in many places infiltrated with leucocytes; the Malpighian corpuscles surrounded by fibroid tissue, some of the glomeruli having undergone a hyaline degeneration, many of the tubules being dilated and filled with urates.

One other case may be mentioned, although beyond the period with which this article deals; but the disease probably commenced at the age of twelve years. A girl of eighteen years was admitted into Guy's Hospital under Dr. Wilks. She had had scarlatina six years before, followed by swelling of the feet. From this time there is a gap in her history until six or seven months before her admission. Since then she had had sickness and shortness of breath. Her legs and face had been swollen for a month only. She was very ill. There was some œdema of the legs, and, to a less extent, of the abdominal wall also. The urine had a specific gravity of 1010, and was very albuminous. Death occurred within a day or two, and upon making the autopsy the kidneys were so much contracted as to weigh three and a half ounces only. Their surfaces were red and sandy or minutely granular in some parts, bossy and fatty-looking in others. On the whole they were fawn-colored. The wasting was more extreme in one: it weighed only one-half to three-quarters of an ounce. The heart weighed ten and

a half ounces, the left ventricle being remarkably tough, although not thick.

With respect to the causes of this state of things, it occurs oftenest after scarlatina, and is probably the result of an insidious subacute inflammation insufficient to give rise to dropsy of more than a slight and transient character. I have seen cases where the anasarca was thus temporary, but where headache and sickness had frequently recurred since, so as to lead one to suppose that the process had been a long-existing and continuous one. But it cannot be doubted that other causes exist, and of these I suspect that gravel and calculus are far more common than has been hitherto taught. At any rate, I have been struck, both in the cases I have seen myself and in those recorded by others,—one of the cases just detailed is an example,—with the frequency with which a shrunken kidney is found associated with a dilated pelvis. A previous obstruction is not absolutely proved by this condition, because all muscular structures falling into disuse become deteriorated in structure and toneless in function, and the dilatation might conceivably come about in that way, and it must be confessed that one can seldom demonstrate the presence of a stone. Nevertheless I hold to the opinion, for calculi are seldom large in childhood, small calculi passing or impacted in the ureters are by no means uncommon, and pathological investigation of recent years has shown that an ascending nephritis, as it has been called, supplies an adequate hypothesis for the setting in progress of a creeping disease such as this.

Again, there is no reason why, as an occasional occurrence,—since we have found that it must be admitted that a primary nephritis other than scarlatinal is not uncommon and is very equivocal in its symptoms,—the overlooked nephritis from an ordinary chill should not lead to such a result,—and, I may also add, the occasional action of various blood-poisons, of which I remember to have seen several years ago a striking example. A marked specimen of a granular kidney was sent to me by Dr. Wilkin, of Beckenham, with this statement, that the girl (about eighteen years old) had been admitted to the hospital and died within a short time from chronic Bright's disease, and the only cause that could be assigned was that she was known to have suffered once from lead colic several (I think eight or ten) years before.

This is, I think, all that can be said of the causes of the granular kidney met with in childhood. As regards symptoms, in the absence of thickening of the vessels and other characteristics, it would appear to be a malady not unlikely to be overlooked until death is somewhat suddenly ushered in, either by convulsions and coma, or by dyspnoea, vomiting, perhaps diarrhoea, and collapse. But I would again insist upon the occasional existence of severe thirst and polyuria in any form of chronic nephritis.

Once the diagnosis is made, the prognosis can only be a hopeless one, even if the issue be some time delayed, and the treatment must follow the lines that have been indicated in the previous sections.

# SURGICAL DISEASES OF THE KIDNEY.

BY HENRY MORRIS, M.D., F.R.C.S.

---

## PERINEPHRITIS AND PERINEPHRIC ABSCESS.

**Definition and Pathology.**—Perinephritis is inflammation of the cellular and adipose tissue surrounding the kidney. When the inflammation has run on to suppuration, perinephric abscess is said to exist. In some cases the suppuration is wide-spread and diffused; in others, only a single, circumscribed, and more or less extensive abscess is present; in others, again, the whole of the perinephric tissue is thickened and indurated by inflammation, and broken down in places into circumscribed collections of pus. If the pus is not evacuated by incision it may burst through the diaphragm into the colon, ureter, stomach, or small intestine, or it may present at the sacro-sciatic notch, or burrow inward across the middle line to the opposite loin. In acute cases the fibrous capsule of the kidney may be very vascular and red, and the cellular tissue surrounding it may be infiltrated with serous fluid. Blood is sometimes effused beneath and around the fibrous capsule. The pathological changes observed in the kidney itself are frequently those to which the perinephritis was due; in other cases the renal changes are secondary to the inflammation in the perinephric structures. There may be general softening of the kidney, but without any purulent dépôts in the secreting substance, or suppuration in the pelvis or calyces of the organ, or the whole or a part of the kidney may be quite liquefied by the solvent action of the surrounding pus and the softening influence of the inflammation.

In some cases pus is found beneath the fibrous capsule of the kidney. The fibrous capsule is sometimes so intimately adherent to the surrounding tissue that they cannot be separated.

**History.**—Since the time of Rayer three classes of perinephric abscess have been recognized,—namely, (*a*) primary extra-renal abscess, or that which is independent of disease within the kidney; (*b*) secondary abscess caused by extension of inflammation from the kidney, but without urinary infiltration; and (*c*) secondary abscess due to a fistulous opening from the kidney into the surrounding cellular adipose tissue. Abrasions of the last kind are commonly, but not invariably, due to renal calculus. Previous to

Rayer's time, only the first of these classes had been systematically recognized or described.

**Etiology.**—Perinephritis and perinephric abscess have been met with at all ages from five weeks old upward. They have been oftenest encountered in males, but are very frequent in females. As the result of injury they may occur in either sex and at any age. In some instances, but few by comparison, they are idiopathic and quite simple in their course and termination. When secondary to disease in the kidney or spine they often run a complicated course and terminate fatally. Blows, strains, punctured and incised wounds in the loins; severe bruising of the loin by the rolling and tossing of a vessel at sea, or by the jolting of a carriage during a long ride over a rough road; over-fatigue in walking; unaccustomed muscular exercise, as digging; falls upon the loin; and simple debility, have all been assigned as causes of primary abscess. A sudden chill, especially after sweating or exposure to great heat, is an exciting cause; so also are various depraved states of the blood, such as occur after an attack of continued or exanthematous fever or any other severe illness. Operations on the testicle, bladder, and vagina, and the formation of pus in the broad ligament of the uterus, have been followed by perinephric suppuration. The most frequent causes of secondary abscess are suppurative pyelitis, nephritis, or pyelonephritis, whether due to calculus, tubercle, cancer, hydatid, or cystic disease, or to suppuration spreading along the ureters from the bladder. In children some of the conditions which in adults commonly bring about renal suppuration are not operative, such, for instance, as prostatic enlargement and organic stricture; but vesical calculus, neglected phimosis, and congenital contractions of the urethra are followed by precisely the same kind of results.

The evidences of chronic perinephritis are often seen after death from these diseases of the lower urinary tract; and in acute cases of the kind the renal capsule is highly vascular and numerous small abscesses may be found in the inflamed surrounding tissue. If time is allowed, these abscesses coalesce and may burrow far and wide, if they do not burst internally into the colon or through the diaphragm or peritoneum. In some cases, without there being any perforation of the renal capsule, inflammation of the perinephric tissue is caused by the presence of miliary abscesses in the cortex of the kidney; in others, by the irritation of repeated attacks of renal colic. Perinephric abscess may arise from inflammation and atrophy but without suppuration of the kidney, and also from tumors of the kidney. Renal fistula due to calculous pyelitis is a very common cause of perinephric suppuration; so also is disease of the spinal column. Inflammation and suppuration may spread along the veins or retroperitoneal tissue from disease of or operation upon distant parts, such as the rectum, urethra, urinary bladder, testicle, tunica vaginalis, or spermatic cord. A pin perforating the colon, an empyema ulcerating through the diaphragm, a typhoid or scrofulous ulcer of the ileum, typhlitis, and perityphlitis, have occasionally excited abscess about the kidney.



**Symptoms.**—The symptoms of perinephritis vary with the cause and the acuteness of the disease, and are by no means always well pronounced. When secondary to disease of some other organ, perinephritis is often masked by the primary affection. When primary, it is often obscure or insidious in character. On the other hand, the symptoms may be evident from the first, and a large fluctuating tumor be developed in the flank in from ten to fourteen days, attended with severe constitutional disturbance.

Perinephritis may often be detected before suppuration has commenced, by attention to the following signs :

The spinal column is prematurely stiff, and curved in the antero-posterior direction, or possibly it will deviate a little from the affected side. There is stiffness in walking, and the body is inclined over to the affected side ; so much so, in some cases, that the crest of the ilium is in contact with the lower ribs. Whilst standing, the body will be flexed upon the thigh of the affected side, and the hand of the same side will rest supporting the trunk on that thigh. The continued flexion of the thigh causes some lordosis in walking. If an effort is made to stand, without support, on the affected side, the body is thrown far over towards that side, and the opposite thigh and leg are strongly flexed. Stooping will be difficult. Whilst lying on his back the patient will not extend the thigh beyond one hundred and sixty degrees, and in more severe cases not beyond one hundred and thirty. There is pain in every movement of the trunk in severe cases, so that the patient may not be able to turn over in bed. Flexion of the thigh will not give pain, but complete extension will not be possible, and its attempt will cause discomfort, if not pain. Abduction and adduction will probably be uninterfered with, but there may be some difficulty in adduction. The patient will be able to stand on the affected limb alone, in the manner described above. In mild cases the limb may look straight whilst standing, but when lying or sitting on a hard mattress the ham cannot be made to touch the surface. Occasionally it has been noticed that the thigh is rotated outward ; when this is so the heel of the affected side during the standing rests upon the dorsum of the other foot. In this state the second stage of hip-joint disease is simulated.

When knee-joint pain is complained of we must beware of mistaking perinephritis for morbus coxæ. With pain in the knee, lameness, and muscular rigidity about the hip-joint, it is too often concluded that we have sufficiently strong evidence of morbus coxæ ; but a cautious examination is requisite before we commit ourselves to this diagnosis.

In perinephritis there is no atrophy of the muscles of the thigh, no shortening of the limb, no fulness or tenderness on pressure about the head or trochanter of the femur, no tenderness or pain on succussion or passive motion of the hip-joint, no tenderness over the sacro-iliac joint, and none on percussing the spinous processes or on succussion of the spinal column. The tenderness in the loin will be above the crest of the ilium, and one or two inches at least to the side of the spines of the lumbar vertebræ. The

tongue will be coated, the temperature raised commonly to 103° F. and often to 104° or higher, and the urine will be acid and without blood or pus, though there will be abundance of lithates and there may be some albumen.

Thus, with feverishness, without tenderness over the spinal column, and with symptoms pointing to an inflammatory affection on one side of the column, there is an absence of the characteristic signs of disease of the hip and sacro-iliac joints, though a very similar alteration in the attitude, and much the same limitation of muscular mobility of the affected side.

In perinephritis there is no tumefaction to be felt in the loin or around the kidney, as in perinephric abscess.

As recovery by resolution occurs, the tenderness in the loin subsides, the temperature declines gradually to 100° F. and then to normal, sitting is less uncomfortable and walking more easy, flexion of the thigh is no longer maintained, and extension in dorsal decubitus can be fully and easily accomplished. The tongue gradually cleans, and the bowels act with regularity as usual. At length all inclination of the trunk to the affected side is discontinued.

When perinephric abscess is forming there are usually the ordinary signs of deep suppuration: rigors, high temperature, sweating, furred tongue, thirst, loss of appetite, perhaps vomiting, and delirium, in the acute cases; constipation, foul tongue, loss of appetite, slight elevation of temperature, in the chronic. In other words, the symptoms will be more or less severe according to the acuteness of the inflammation. In old and weakly persons, and when the inflammation is chronic, the symptoms may be altogether masked, until the abscess, by its size and pressure upon surrounding structures, forces itself upon the attention. In some subacute cases the only symptom for several weeks before pus was discovered, or even suspected, has been lameness, attributed to morbus coxæ or to rheumatism.

The febrile temperature does not always take the same course: in some cases it is like the course of typhoid, running continuously high; in others it is intermittent, and suggestive of malaria or pyæmia. Obstinate constipation is a very frequent symptom, and is doubtless due to the loss of muscular effort or to the patient's dread of employing it.

Of the *local symptoms*, those due to pressure are more marked in perinephric abscess than in perinephritis. Pain is one of the earliest and most prominent indications. Its common seat is the loin and side of the abdomen, but sometimes it shoots down the thigh or into the hypogastrium, scrotum, penis, testes, or groin. This wide diffusion of pain is explained by the anatomical distribution of the nerves of the lumbar plexus, which traverse the renal region. It is in one case of a dull aching character, in another darting or pricking. Occasionally it may be felt in the knee, as in coxalgia. In most cases it continues and increases until the pus is evacuated; but in other cases the severity of the pain diminishes temporarily, or disappears entirely for weeks or even months, encouraging a delusive hope

that recovery has taken place. If the loin be compressed between the two hands the suffering caused is in some instances very acute.

The affected side will often give to the surgeon the sense of increased resistance and weight long before pus has formed. This condition will be best detected by lifting, as it were, each loin by the flat hand placed behind each ilio-costal interspace. A feeling of weight in the side is sometimes experienced by the patient. Later on there will be dulness and swelling in the ilio-costal interspace. The skin in the loin may be either waxen and œdematous or congested. After a time deep-seated fluctuation may be detected in place of the hard resistance previously felt; but this will depend much upon the thickness of the abdominal parietes.

Retraction of the testis has been noticed in some cases: it is most likely to occur when perinephric abscess is caused by calculous pyelitis, but is not restricted to such cases.

Œdema of the foot and ankle may precede for many weeks every other sign of perinephric abscess.

A peculiar lameness is often an early symptom, and is due to the flexed position in which the thigh of the affected side is retained. Sometimes the patient walks with the body bent forward and inclined to the affected side, with the hand of the same side resting on the middle of the thigh; and he sits on one tuber ischii, so as to relax the psoas muscle of the other side. The psoas muscle may serve to guide the pus either downward to the groin or upward beneath the arcuate ligament of the diaphragm into the pleural sac or the lung.

An inability to extend the thigh of the affected side is sometimes an early symptom; the limb is kept flexed on the abdomen, and any attempt at extension causes pain. Other movements, such as adduction, may be painful; or there may be anæsthesia or motor paralysis of the thigh of the diseased side.

The pus contained in some cases is quite odorless, in others fetid; in a few it has a fecal odor, even though no fistulous communication with the bowel exists.

The urine may contain albumen, from pressure on the renal vein, or pus and blood, due to primary renal disease; or it may be quite unaffected in quality and quantity. Vesical irritation is an occasional symptom. Sometimes there is pleurisy or pneumonia on the affected side masking the perinephritis, and the patient appears to be suffering exclusively from disease within the chest.

As soon as the pus is evacuated the temperature falls, the pain vanishes, the appetite returns, and the flatulence and constipation disappear. The patient rapidly recovers, provided the incision of the abscess has been made before the pus has burrowed too widely or the inflammation has set up some dangerous complication.

**Diagnosis.**—The affections which may be mistaken for perinephritis or perinephric abscess are lumbago, nephralgia, various organic diseases of the

kidney, spinal caries, perityphlitis and perityphlitic abscess, splenic and hepatic tumors, fecal accumulations in the colon, empyema, pneumonia and abscess of the lung, typhoid fever, morbus coxæ, and psoas abscess.

In lumbago the pain is felt on both sides of the spinal column, is unaccompanied by fever or swelling, and does not shoot to the front of the abdomen or the groin. In nephralgia the pain is paroxysmal, and the local signs of perinephritis and the flexion of the thigh are wanting.

The diagnostic signs of organic renal diseases are described under their respective headings. In disease of the spinal column there is pain around the trunk along the course of the spinal nerves, the body is held stiff, and there is no rotation or inclination of the trunk towards one thigh. In perityphlitis the pain, swelling, and tenderness are in the iliac fossa, not in the ilio-costal interspace. Fæcal accumulations and the pain they cause are removable by aperients. Empyema and pneumonia have their own special signs, and never give rise to thigh-flexion. In typhoid there are no evidences of local inflammation in the loin, and there are the characteristic temperature and tongue and rash, the tumid abdomen and the big spleen.

From morbus coxæ perinephritis is to be distinguished by the high seat of pain and the painlessness of passive flexion, abduction, and outward rotation of the thigh without any attendant movement of the hip. Neither is there fulness of the hip-joint nor tenderness on pressure on the trochanter.

**Prognosis.**—The prognosis is always grave. The duration of the disease varies from two or three weeks to many months. In a few cases perinephritis ends in resolution before the suppurating stage has been reached. When suppuration occurs the prognosis depends chiefly on two things,—the early and free evacuation of the pus, and the cause of the disease.

If the abscess bursts into the lung, colon, or ureter, recovery may ensue if the cause of the disease is removable; or death may occur from pyæmia, hectic, or gangrene of lung. If the abscess bursts into the peritoneum, death quickly follows from peritonitis; if into the pleural cavity, empyema may terminate fatally. Syncope and apnoea may be caused by pressure of the abscess.

**Treatment.**—Primary perinephritis may be sometimes checked in its early stages by local blood-letting by means of leeches or the cupping-glass, and by hot baths and hot emollient poultices or stupes. When the acuteness of the symptoms has passed, or the inflammation is of the subacute or chronic character, absorption of the inflammatory products may follow blistering, or hot fomentations applied over some absorbent ointment, such as iodide of potassium or iodide of lead. The bowels should be well opened at the onset by a brisk purgative, and kept acting moderately by enemata or mild laxatives. Pain must be relieved by opium. The diet should be milk, beef tea, or something equally simple and as readily digested. As soon as the presence of pus is suspected it should be at once searched for with the aspirator, or by an exploratory incision in the loin. When matter is detected it should be let out through a free opening in the loin. Ther

should be no waiting for fluctuation; the increasing fulness, hardness, and tenderness, and perhaps the commencing redness and cedema of the skin, are ample signs to demand an incision. The incision may be either vertical, oblique, or transverse, and after dividing the integument and muscles with a knife the suppurating area should be entered by the finger. The kidney should be explored with the finger, if possible, in the abscess-cavity, any loose sloughs of cellular tissue removed, and the abscess washed out with an antiseptic lotion. A drain-tube should be inserted, and the loin enveloped in a carbolic and lead lotion, or covered with a layer of antiseptic cotton-wool or gauze.

The wound must not be allowed to close too early, but the drain-tubes should be retained until they are forced out by granulations.<sup>1</sup> Even when no pus is found at the time of incision, much relief follows by the removal of tension, and pus often escapes some time after the operation. A fistula will occasionally persist for a long while after the discharge of the abscess.

#### HYDRO-NEPHROSIS.

**Definition.**—Hydro-nephrosis is the term given to the overdistention of the kidney with urine. It is a mechanical result of obstruction to the outflow of urine from the kidney, no matter whether the cause of the obstruction be situated in the ureters, bladder, or ureter, nor whether a renal tumor appreciable during life be formed by the dilated kidney or not.

**Etiology.**—The causes of hydro-nephrosis are (1) congenital and (2) acquired. Probably one-third of the cases in which a palpable tumor is formed have a congenital cause.

The congenital causes do not always give rise to hydro-nephrosis in infancy or very early life. There are several cases on record which show that a congenital cause has acted very slowly and incompletely, if at all, for a long time, but that after some, even many years, a hydro-nephrotic tumor has been formed and terminated fatally. Hydro-nephrosis due to a congenital cause is not, therefore, the same thing as “congenital hydro-nephrosis.”

Among the *congenital causes* are twists of the ureter upon its own axis, undue obliquity, reduplications, folds, contractions, and other anomalies of the ureter. Sometimes the ureter has been found in part, or throughout, a fibrous cord; but in such cases the hydro-nephrosis exists at birth, though it increases afterwards.

In other cases the vesical orifice of the ureter is thick, rigid, and of merely pin-hole size; in others, again, minute cysts are developed within its mucous membrane; in others it joins the kidney at such an angle that urine can only with great difficulty flow through it. An abnormal renal artery may compress the ureter and so produce obstruction; so may an abnormal flap of membrane in the pelvis of the kidney or in the urethra.

The *acquired* causes of hydro-nephrosis are numerous, and, like the

<sup>1</sup> Nutritious food, tonics, and possibly a limited amount of stimulants will be requisite.

congenital, may be situated in, behind, or in front of the bladder. Impaction of calculus in the ureter, vesical calculus, fibromata and other growths within the bladder, the pressure of tumors, or of bands of organized inflammatory lymph, traumatic stricture of the urethra, contractions of the ureter from injury, such as kicks or blows, or the effects of the passage of a renal calculus, and undue frequency of micturition continued for a long period, are all well-authenticated causes of renal distention.

Hydro-nephrosis may affect one or both kidneys, or may be limited to part of one kidney. The latter condition has been sometimes found in children having kidneys provided with double ureters: in some of these cases the cause has been congenital narrowing, in others tubercular disease of one of the ureters.

The proportion of cases in which hydro-nephrosis produces a palpable abdominal tumor is very small, compared with the frequency with which the condition is met with in the post-mortem room.

**Pathology.**—The pelvis of the kidney first becomes converted into a spheroidal sac, then the calyces are widened and stretched in every direction, and at length the capsule of the kidney is expanded, and what remains of the cortical and medullary substance of the organ becomes still further compressed and absorbed, until finally nothing remains but a more or less completely loculated bladder or cyst. Thus the tension exerted by the urine, which accumulates behind the obstruction, stretches the calyces and flattens and wastes the pyramids to such an extent that the calyces are converted into huge spaces or pouches jutting off from the dilated pelvis and separated from one another by slender septa formed by the wasted "columns of Bertini." On laying open the cavity of such a hydro-nephrotic cyst, nothing but a complete fibrous skeleton of the kidney will be seen. Sometimes nothing but a pellucid sac, with at most one or two, if any, septa, is present; generally, however, areas or a cortex of the secretory substance remain. In rare cases some of the dilated calyces are shut off from the others either by a layered calculus or by fibrous septa.

The walls of the sac are in some instances thin and translucent, in others thick, tough, strong, and even cartilaginous. The size of a hydro-nephrotic kidney may not exceed the normal size of a kidney; it may be even smaller. On the other hand, it may hold many gallons of fluid. The contents of the sac are rarely like natural urine. Often the fluid is odorless, gives no reaction with heat or nitric acid or with cupric tests, has a low specific gravity, leaves scarcely any residue on evaporation, and affords no evidence of urea or uric acid; in fact, it is only water holding a larger quantity of chloride of sodium in solution and containing a few epithelium-cells. This has been the character of the fluid in congenital as well as in acquired cases of advanced hydro-nephrosis.

Uric acid, urates, and oxalate of lime may be found in the fluid. At other times the contents of the cyst are turbid and mixed with muco-pus, or with blood-clot of old or recent date which gives a brown or red color

to the fluid. At others, again, urea and chlorides may be found in it as in natural urine; and this, too, even in congenital hydro-nephrosis. Epithelial and granular cells, phosphates, and albumen are frequent constituents.

Sometimes the contents are colloidal in character. Cholesterine has also been found in the fluid.

Adhesions may exist between the sac and the surrounding parts, such as the peritoneum, omentum, mesentery, pancreas, liver, spleen, or intestines.

**Symptoms.**—Hydro-nephrotic distention affects each kidney about equally. It occurs at any period from birth to extreme old age, and is met with also in the fœtus. It is nearly twice as frequent in females as in males. When the dilatation is insufficient to give rise to a tumor, there are generally no symptoms characteristic of hydro-nephrosis. It must, however, be borne in mind that the whole round of morbid changes described above may be inflicted upon the kidneys without there being any sign of an abdominal swelling.

In some advanced cases in which there is no tumor, symptoms are excited simply by the obstruction: these are thirst, pain in the back, frequent micturition, total or partial or intermittent anuria, and obscure or pronounced pains in the abdomen.

When the disease is bilateral, uræmia may be looked for. Vomiting, convulsions, and febrile manifestations are occasional symptoms.

When a tumor is formed, hydro-nephrosis may destroy life by bursting into the peritoneum or in some other dangerous direction.

The tumor is dull on percussion, sometimes irregular or lobulated in outline, and frequently fluctuates. By its size it may cause much pain, displacement of viscera, disturbance of the action of the diaphragm, and thus of the lungs and heart, and it is especially prone to interfere considerably with the action of the colon, thus inducing constipation. In exceptional cases the tumor distends the whole abdomen, bulges out the lower ribs, and looks like an immense ovarian cyst.

If it arises from some painless cause, its development is unattended by any constitutional or local disturbance; but if from some painful cause, such as impacted calculus, the symptoms incidental to the particular cause will occur before the tumor makes its appearance, and will probably mask the development of the swelling.

The tumor has all the characters of a renal tumor, being situated in the flank, pressing backward and outward the parietes in the ilio-costal area, having the colon in front of it, and the small intestine either in front or thrust over to the opposite side of the abdomen, according to the bulk of the swelling.

The tumor extends beyond the median line of the body in about one-fourth of the cases, and in one-third of these it at length occupies the greater part of the belly.

There are instances of the tumor intermitting, being prominent at one time and not distinguishable at another. In many the tumor diminishes

from time to time without actually vanishing, the subsidence of the swelling being followed by the discharge per urethram of an increased quantity of urine. In such cases the urine during the increased flow will sometimes yield an admixture of blood, pus, or mucus, but will always be of a lower specific gravity than normal urine. At other times, and in cases which do not subside or intermit, the urine gives no information whatever.

A hydro-nephrotic tumor may be quite painless when small; but when large the pain may be of the most agonizing character.

**Diagnosis.**—Hydro-nephrosis has to be diagnosed from renal abscess, perinephric abscess or extravasation, pyo-nephrosis, hydatid or serous cysts of the kidney, liver, or spleen, and, when of very great size, from an ovarian cyst or general ascites. Subsidence of the swelling followed by an increased excretion of urine is almost conclusive of hydro-nephrosis; but this rarely occurs, so that we have to rely on other points of diagnosis.

The absence of rigors and fever, of œdema and redness of the loin except when the hydro-nephrosis is of large size, the slow formation of the swelling, the existence of some obstruction to the passage of urine, and, lastly, the circumscribed outline of the tumor, will generally suffice to establish a correct diagnosis. The history of the case will often serve to exclude hydatid and serous cysts; if a hydatid vesicle has escaped with the urine all doubt is at once cleared up. Hydatid tumors of liver and spleen bulge more commonly towards the front than into the loin, and, moving with the organ in which they grow, are displaced more markedly during respiration. When of great size the hydro-nephrotic tumor is most likely to be mistaken for ovarian disease; but the direction of growth, its relation to the colon, and the evidence afforded by vaginal and rectal examination will generally prevent error.

**Prognosis.**—This depends on the cause of the obstruction, and on whether one or both kidneys are involved. If only one kidney is affected, life may be indefinitely prolonged, provided the size of the tumor is not great, or, if the tumor is large, provided relief from distention is afforded in good time. If the distention increases, death will result from the effects of pressure on neighboring organs, from rupture into the peritoneum, from suppression of urine, or from uræmia. Traumatic rupture of the cyst has been the termination of more than one patient. In most cases where the distention affects both kidneys, the cause of the hydro-nephrosis kills the patient, though even then one of the chief factors in producing the fatal result is the destruction of the glandular substance of the kidney, and the gradual cessation of the renal function.

In some cases the tumor has spontaneously subsided and never returned: this was the termination in six cases out of a total of forty-seven. There is always the fear lest a calculus or some affection of the opposite kidney may cause death by suppression of urine or by uræmia.

**Treatment.**—The treatment of hydro-nephrotic tumors is purely surgical; nothing can be done for them by medicinal remedies. When of



small size, painless, and not on the increase, they may be left alone. When they cause trouble, either by their weight, pressure, or size, the aspirating-needle should be employed when there is any reasonable ground for believing that the cause of obstruction is temporary and that reaccumulation is not likely to occur.

An attempt might be made to overcome the obstacle to the passage of urine by friction. In children this treatment has met with some success; but it must be employed with caution, for fear of rupturing the cyst.

The use of the aspirator, sometimes repeatedly upon the same tumor, has been fairly successful. The best point to puncture is half-way between the last rib and the iliac crest, about two and one-half inches or more behind the anterior superior iliac spine, or else just anterior to the last intercostal space. If the tumor points at any spot, this should be selected for introducing the aspirating-needle. Aspiration may effect a complete cure, either by relieving pressure or releasing some curve or twist of the ureter. Sometimes a single tapping has sufficed; more often repeated tapplings have been required before fluid ceased to reaccumulate in the renal cavity. When aspiration fails, nephrotomy through the lumbar incision ought to be employed. Care is required in aspirating not to puncture too far forward and thereby wound the peritoneum or provide for the escape of urine into the peritoneal cavity. It is not advisable to inject into the renal pelvis after withdrawing the contents any stimulating fluid, such as tincture of iodine, with a view to excite adhesions and contractions of the cyst-walls.

Nephrotomy is performed by cutting obliquely in the ilio-costal space through skin and muscles down to the distended kidney. As soon as the cyst is exposed through the wound in the loin it should be tapped and the fluid withdrawn; then the puncture-hole should be enlarged with a bistoury, and the edges of the cyst stitched to the edges of the wound in the abdominal parietes. If the lumbar incision is made high and carried far enough forward, plenty of room is obtained, so that the cyst-wall can be readily drawn up into the loin-wound.

Drainage and antiseptic irrigation are effected by means of a large rubber tube, which should be fixed in the cyst, and Condy's fluid, or thymol or weak carbolic acid in solution, should be passed through it daily.

This practice has been very successful, and ought certainly to be adopted when aspiration fails and before nephrectomy is dreamt of.

After nephrotomy has been performed, search should be made with a sound or long probe for a calculus or other foreign body obstructing the renal pelvis or the upper end of the ureter.

*Lumbar nephrotomy* may be recommended when a fistula in the loin is permanent and there is little or no secreting structure left.

#### PYO-NEPHROSIS.

**Definition.**—By pyo-nephrosis is understood dilatation of the pelvis and calyces of the kidney with pus, or pus and urine. It is a mechanical

result of obstruction, and something more. It is hydro-nephrosis with pyelitis superadded. Sometimes the amount of pus is so small, the pyelitis so slight, and the amount of pent-up urine so large, that the tumor is called hydro-nephrosis rather than pyo-nephrosis, in spite of the presence of pus. But in all cases where there is suppuration as well as dilatation of the pelvis and calyces of the kidney, the condition is, strictly speaking, pyo-nephrosis.

In advanced cases the dilatation and suppuration extend beyond the calyces and go on to the compression, atrophy, and breaking down of the medullary and cortical substance, until at length the whole kidney is converted into a large and loculated sac. This sac contains pus or purulent urine, or urine mixed with mucus-pus in larger or smaller quantity, or pus and urine mixed with blood or with a white phosphatic deposit or mortary paste of phosphate of lime, or debris of renal calculi, according to the cause of obstruction.

**Etiology.**—Hydro-nephrosis becomes pyo-nephrosis when pyelitis is superadded. The causes which produce hydro-nephrosis produce also pyo-nephrosis. But when an obstruction at once excites pyo-nephrosis it is more complete and irritative in its effects upon the kidney than those which give rise to hydro-nephrosis.

In some cases the pyo-nephrosis has been preceded by pyelitis, the distention being excited by the same cause, but at a later date. Pyelitis followed by pyo-nephrosis sometimes results from wounds and contusions in the renal region.

**Pathological Anatomy.**—The mucous membrane of the renal pelvis by degrees assumes a dull-white color, very different from the bluish-white semi-transparent color of health, is markedly thickened, and secretes a quantity of pus. The pent-up urine soon becomes alkaline from admixture with the pus, the urea is converted into carbonate of ammonium, and calculous material is often deposited upon the lining membrane of the organ. The thickening of the mucous membrane is sometimes so marked, and the dilatation and distention of the calyces and pelvis so considerable, that the orifices whereby the pouch-like dilatations of the calyces communicate with the pelvis become excessively narrow, occasionally altogether closed by fibrous dissepiments or partitions. As the distention of the cavity of the kidney proceeds, the pyramids and then the cortex of the kidney become more and more atrophied, until at length all the glandular tissue is completely removed and the organ is transformed into a many-chambered cyst, the departments of which open into the dilated pelvis.

Ulceration of the cyst-wall or suppurating tracks formed through what remains of the renal substance sometimes end in fistulous openings into the parts around,—it may be into the cellular tissue of the loin, or into the stomach, duodenum, colon, or peritoneum. Sometimes only one, sometimes several fistulous openings occur in the same case. As soon as a fistula forms, the purulent urine escapes, and gives rise, according to circumstances,

to perinephritis, peritonitis, or the discharge of pus and urine by the mouth or rectum or through the loin.

**Symptoms.**—In the early stages the symptoms of pyo-nephrosis will be those excited by the cause of the obstruction, whatever that may be, and, in addition, those of pyelitis. If the obstruction is not complete there will be pus in the urine; if complete, but intermittent, there will be intervals when no pus is discharged; whilst if the obstruction is both complete and permanent there will be an entire absence of pus in the urine. The urine should, therefore, be carefully and frequently examined, as to both quantity and quality, in each of which it may vary from time to time a good deal. The urine may decompose in the renal pelvis and become alkaline and glairy, as it does in cystitis, but when mixed with the urine from the opposite kidney these characters are so moderated that the urine is usually faintly acid when voided.

There will be constitutional symptoms of suppuration; sometimes shivering, sometimes a high temperature at night without rigors; emaciation, great prostration of strength, loss of appetite, perhaps sickness and diarrhoea, and often a dusky pallor or sallow tinge of skin. When pyo-nephrosis becomes chronic, hectic may supervene. The tumor caused by pyo-nephrosis varies in different cases as to size and other characters, just as it does in hydro-nephrosis.

The pain experienced depends greatly on the size of the tumor: there are in some cases paroxysms of great severity. Pressure over the front of the tumor nearly always aggravates pain, or provokes it if it was not present before. Pressure over the flank, in some cases, is not only well borne, but actually gives relief.

If the opposite kidney is useless, death from anuria may occur. Anuria has been known to result from obstruction of one kidney alone.

**Diagnosis.**—The tumor caused by pyo-nephrosis will be diagnosed in the same way as that of hydro-nephrosis; and, as pyo-nephrosis is nearly always preceded and accompanied by febrile symptoms, by rigors, and by the presence of pus in the urine in varying amount, we are enabled thereby to distinguish pyo-nephrosis from hydro-nephrosis.

From perinephric abscess the tumor will be made out in the same way as in hydro-nephrosis; but the feverishness and other constitutional signs of suppuration make pyo-nephrosis more likely than hydro-nephrosis to be mistaken for perinephric abscess.

**Prognosis.**—When due to a removable cause and confined to one kidney the prognosis as regards life is not unfavorable, if early relief to pent-up urine and pus is obtained, either by the restoration of the passage along the ureter or by lumbar incision. When the tumor continues to increase, death will be caused by pressure-effects or by its bursting into some important cavity or organ. When it opens on the surface of the body or into the bowel, recovery may take place, but death from blood-poisoning, hectic, or exhaustion is probable. The most favorable result is when the ob-

struction ceases and the contents of the tumor discharge along the ureter. Sometimes after the tumor subsides pus is passed in the urine for very long periods or even for the rest of life.

**Treatment.**—In the early stages the treatment is directed to the removal of the obstruction and the improvement of the pyelitis. Even when a tumor is formed, palliative treatment is permissible when there is not complete obstruction and the pus and urine can escape by the ureter; when there is neither fever, hectic, diarrhœa, emaciation, nor pain, and the tumor is not of such a size as to threaten rupture; when the tumor, from having been of large size, has diminished by the emptying of the cyst along the ureter into the bladder; when the surrounding organs and tissues are not excited to inflammation; and when the age of the patient, or some serious complication of bladder or other organ, renders any operation a danger in itself.

Under these circumstances we shall help to diminish the suppuration, and prevent the occurrence of acute inflammatory action in the cyst, by rest in bed or on the couch, frequent hot baths, anodyne and emollient applications to the loin and abdominal walls, gentle compression by belladonna plasters, the avoidance of constipation and of the accumulation of fecal matter in the colon and cæcum, and by a light digestible diet, properly regulated according to the constitution of the patient.

If a calculus be impacted in the ureter, an attempt in a very serious case should be made to extract it, either through the bladder or by abdominal section. Or friction over or manipulation of the tumor and adjacent parts might be tried. If the parts are very painful, friction must be tried only under chloroform; and it is not free from danger through increasing inflammation or rupturing the cyst.

In many instances, however, the only proper treatment is nephrotomy, palliatives being useless, and delay in operating dangerous. The circumstances which indicate nephrotomy are constant pain, increasing size of the tumor, continued fever and evening elevations of temperature, serious interference with the functions of the stomach and intestine by reflex irritation or direct pressure of the tumor; when the surrounding structures are inflamed or becoming adherent to the tumor, and when the tumor threatens to rupture or ulcerate into them.

As the several calyces may be shut off from one another, each suppurating cavity should be opened, either by the knife or by the finger, and search should at the same time be made for renal calculus in the pelvis or impacted in the upper end of the ureter.

Lumbar nephrectomy will have to be considered if, after opening and draining the cyst, free suppuration continues, or fresh abscesses within or around the kidney occur and do not permit of thorough drainage through the loin.

#### RENAL CALCULUS.

**Definition.**—There is but a step between the formation of gravel and of stone in the kidney. If the solid substances which are usually in a state

of solution in the urine become excessive, so as to be deposited as crystals, and if these crystals are carried out of the system with the urine, we have the condition of gravel. If these crystalline forms are cemented together by a little mucus or blood-clot, and are afterwards added to by fresh depositions from the urine, we have a small calculus, which may either be passed off with the urine, causing more or less renal colic in its transit along the ureter, or may remain behind in one of the calyces or in the pelvis of the kidney, there to grow by fresh accretion until it attains a size altogether in excess of anything which can pass along the ureter.

**Etiology.**—Renal calculus may originate in the deposit of some of the urine-salts around a blood-clot in the renal pelvis, the result of an injury. More frequently it results from a precipitation of some of the solids of the urine which are in excess of the normal amount, this excess, as a rule, being dependent on an error of diet, imperfect digestion, or defective nutrition. Sometimes it is excited by the presence of a sarcomatous or papillomatous growth in the kidney. Renal calculi are formed at all periods of life from the latter weeks of intra-uterine life onward. They are very common in the children of the poor up to the age of fifteen years. The majority of the sufferers from stone in the kidney among the poorer classes are children. It is a rare disease among the children of the well-to-do. The absence of milk and the use of indigestible articles of food in the diet of the children of the poor is probably the cause of the prevalence of renal calculus among them.

Calculus may form in the uriniferous tubes or calyces of the kidney, but it generally grows into importance after it has reached the calyces or pelvis.

The most common form of renal calculus is the uric acid, the next most common is the oxalate of lime. These substances, being but sparingly soluble, are the most likely to be precipitated from the urine; but carbonate of lime, phosphate of lime, a mixture of phosphate and the ammonio-magnesian phosphate (that is, the fusible calculus), cystine, xanthine, and finally urate of ammonium, or the mixed urates, are found occasionally, though rarely, either as the nucleus or chief constituent of renal stones. Alternating calculi of uric acid, oxalate of lime, and phosphates in distinct layers are not uncommon. Blood calculi have been described, and a drop of dried blood is occasionally found as the nucleus of a mixed calculus.

The nucleus of calculi formed in infancy is generally urate of ammonium; at puberty and in young adults it is uric acid; but uric acid, oxalate of lime, and triple phosphate of lime occasionally form the substance of calculi in children.

**Pathological Anatomy.**—One single calculus or many hundreds may be formed in the same kidney. When there are many, they are scattered throughout the organ, sometimes as grit studding the tissue, and sometimes in nests or excavated spaces in the tubular substance. When single, the size and shape of the stone vary from a small smooth body faceted or rounded, to a large, branched, rough mass filling all the pelvis and calyces.

A stone as large as a marble, rough and sharply mammillated upon its surface, may remain confined to one of the calyces for years without giving rise to more change than induration of the whole organ, due to slight chronic interstitial inflammation. On the other hand, quite a minute stone, not much, if any, larger than a mustard-seed or grape-seed, whilst in the tubular structure of the kidney will excite congestion and even acute inflammation and abscess.

When a stone is of such large size that it fills the renal pelvis, or when, being much smaller, it falls like a ball-valve into the upper end of the ureter, it leads to chronic inflammation, to dilatation, and to those atrophic changes which accompany hydro-nephrosis and pyo-nephrosis; or nephritis, pyelo-nephritis, abscess in the perinephric tissues, or profuse suppuration within the kidney may be the result.

**Symptoms.**—Renal stones of small size may pass out of the body in considerable numbers without giving rise to more than slight lumbar pains. A moderate-sized and even a large stone may exist for years without revealing its presence at all, or, after having for a time caused symptoms, may for the rest of a long life remain dormant.

As a rule, there is, at some time, blood or albumen mixed with the urine, lumbar pain or aching, aggravated by exercise or by any jolting movement, vesical irritability, or perhaps pain in the testicle of the same side. If the stone has existed a long while, pus, mucus, or albumen will be found daily in minute or moderate or marked quantity in the urine; or if blood is not always present (and in many cases it is not) it may recur from time to time in large amount, making the water bright red or porter-like in color for several days together. If with these symptoms the patient occasionally passes gravel or minute calculi or fragments of calculous matter, the diagnosis becomes conclusive.

Movements such as those caused by carriage-exercise, running, or walking, are not in all cases needed to excite exacerbation of the lumbar pain; on merely turning in bed, or even when lying asleep, the patient may be aroused by a sudden agonizing seizure.

It would thus seem that the varying pressure of the abdominal viscera, the passage of feces along the colon, the variations in the degree of intra-renal blood-pressure, are all capable of exciting pain by making the renal tissue press against the often acicular surface of the calculus. As soon as a stone enters the ureter, or is being propelled along it, stretching it as it goes, renal colic sets in. The attacks of renal colic come on suddenly, last for two or three hours or as many days, and almost as suddenly subside, to recur at some future period, if the stone, instead of escaping at the lower end of the ureter, is simply displaced from the upper orifice into some less important point in the renal pelvis. Recurring attacks of colic arise from fresh formation of renal calculus.

Periodic attacks of renal colic occur in some cases without being followed by the discharge of a calculus or a fragment of a calculus. They are

then due to the irritation of a movable calculus in the pelvis of the kidney, or to the passage of a lump of mucus or blood along the ureter. They are more prone to occur or to be most severe when the patient is in low health or over-fatigued.

During these attacks the pain shoots along the branches of the lumbar plexus, and is felt in the bladder, in the groin, along the thigh, or in the testicle. The pain is paroxysmal, and intensified by the spasmodic contractions of the ureter. The testicle may be retracted at the time, and afterwards become enlarged and remain for a long while tender, if not painful. I have seen the testis of the affected side small and wasted as well as retracted. Children may be thrown into convulsions during the fearful agony of renal colic. The attack is often ushered in with a rigor, and is generally accompanied by vomiting, retching, and profuse perspiration. Faintness and collapse are by no means rare. The bladder is irritable, and the urine, which is diminished in quantity during the attack, is blood-stained and loaded with urates, and is sometimes passed with a good deal of scalding in the urethra. It sometimes happens that the other kidney becomes excited to increased secretion during the attack, and then the urine will not be diminished in quantity, and will not be thick.

Apart from the attacks of renal colic, constant or paroxysmal lumbar and renal pain is a very common symptom of a stone in the kidney.

Owing to the wide nerve-connections of the kidney, the pain of renal calculus is often transferred to a distance,—*e.g.*, to the testes along the spermatic plexus and the genito-crural, to the upper part of the thigh by the genito-crural, to the leg and inside of the foot through the anterior crural.

A stone in one kidney sometimes excites pain and irritation in the other. This transferred or sympathetic pain is of an aching character, not often of a colicky nature.

Another symptom which results from transference of nerve-influence has reference to the stomach: nausea, vomiting, and dyspepsia are very common, not only at the times of actual colic, but also during the periods of less acute suffering, being due to the connection of the pneumogastric with the renal plexus. The retraction of the testicle, irritability of the bladder, pain referred to the thorax and sometimes thought to be due to pleurisy, are all explained in the same manner as the gastric disturbance and the pains in the lower limb,—namely, by transference of nerve-influence.

When the patient is very thin, and the stone large, it can sometimes be detected on palpation of the loin, especially when the patient is under the influence of chloroform.

Other common symptoms of renal calculus are hæmaturia and pus in the urine. These vary much in frequency and amount. As a rule, oxalate-of-lime calculi cause most bleeding, phosphatic calculi most suppuration. Lateral inclination of the body and flexion of the thigh are not unusual.

**Diagnosis.**—Undue acidity of urine and strumous disease of the kidney are the two conditions in children which are most likely to be mistaken for

renal calculus. Renal tumors, intestinal colic, and perityphlitis have also occasionally given rise to errors in diagnosis.

Acidity of urine and excess of uric acid in the urine will be removed by alkaline treatment and precautions in diet; there may be frequency of micturition, tenderness of the testicles, and even hæmaturia, but renal colic does not occur, and the lumbar pain or aching is equally on both sides.

Strumous kidney must be suspected when frequency of micturition and slightly purulent urine occur in children of strumous habit or parentage. The absence of hæmaturia makes this diagnosis more, rather than less, certain. Frequency of micturition, with pus and hæmaturia and sharp lumbar or testicular pain, in a healthy child, is almost certainly due to calculus. Struma and calculus sometimes affect the same organ.

From intestinal colic and perityphlitis renal calculus can be distinguished by the localized pain in the loin, the hæmaturia and pus in the urine, the absence of fever, the frequency of micturition, and the testicular pain.

From carcinoma or sarcoma of the kidney calculus may generally be diagnosed by the absence of tumor and the longer duration of the symptoms before the general health of the patient becomes deteriorated. The irregular shape of the tumors and the frequency with which they extend down into the false pelvis serve to distinguish these new growths from calculous hydro-nephrosis and pyo-nephrosis.

**Treatment.**—The treatment of renal calculus may be considered under three heads: (1) prophylactic; (2) palliative; and (3) surgical.

*Prophylaxis* consists in employing a moderate amount of well-selected food, so as to preserve the digestive and assimilative functions in good order. Animal diet is not harmful if taken in moderation, nor is abstinence from animal diet any security against calculus, as is proved by the prevalence of this disorder among the very poor, who scarcely taste meat.

*Palliative treatment* consists in the free use of alkaline drinks or distilled water; in the administration of acetate of potassium, carbonate of lithium, citrate of potassium, or carbonate of lime, and of saline aperients, such as sulphate of sodium, sulphate of magnesium, and tartrate of potassium and sodium. The natural mineral waters of Vichy, Ems, Carlsbad, Püllna, and Friedrichshall are advantageous; and with an undue disposition to the formation of uric acid the alkali mineral water of Fachingen is the best. During an attack of pain, confinement to bed, hot baths and anodyne fomentations, and anodynes internally, are the treatment.

*Surgical Treatment.*—The treatment by operation of the worst pathological consequences of renal calculus have been considered under pyo-nephrosis and perinephric abscess. Nephrectomy will very rarely be justified for calculus uncomplicated by abscess and disorganization of kidney.

Nephrolithotomy should be performed when symptoms of stone are severe and are not removed or rendered bearable by several months of medicinal treatment and rest, when the patient is compelled to pass his days as well as



nights in bed, or when anuria supervenes upon symptoms of calculus in one or both kidneys. In the latter case (*i.e.*, when both kidneys are affected) the kidney which has last become affected should be first explored.

The symptoms which are sufficiently characteristic of stone in the kidney to justify an exploration of the kidney in search for the stone are a history of hæmaturia, the presence of a little pus or of crystals in the urine, together with fixed or more or less constant pain in one loin, groin, or testicle, the pain being either of a dull aching or sharp pricking kind, paroxysmal, and occasionally associated with the other symptoms.

When a fistula leading down to a calculus opens on the surface, all that may be requisite to extract the stone is simply to enlarge the opening and seize it with a proper pair of forceps. When a retroperitoneal abscess is present the stone will probably be detected at once on opening the abscess from the loin. In either of these cases the calculus very probably will be found lying outside the kidney, from which it has escaped by ulceration.

#### TUBERCULAR AND SCROFULOUS KIDNEY.

Of twenty-eight children under twelve years of age, nineteen had both kidneys affected, five the right only, and four the left only.

Two forms of tubercle (so called) of the kidney are met with: (1) disseminated tuberculosis, and (2) strumous pyelitis, or scrofulous pyelonephritis.

These diseases are more common in children and below the age of puberty than in adult life; but they may occur, and more especially the scrofulous form of the affection, at any age. Males are said to be more frequently affected than females. Both kidneys are rarely involved in an equal degree, and the "scrofulous" form often affects one kidney only.

**History and Pathology.**—Miliary tuberculosis affects children under ten years of age in a much larger proportion of cases than the scrofulous caseous variety. Miliary tuberculosis generally affects both kidneys. The kidney is affected as part of a general constitutional disease. The miliary nodules begin as gray granulations around the terminal branches of the arterioles which lie between the pyramids of Ferrein. They infiltrate the vascular and connective tissues, and flatten the uriniferous tubes between which they occur. They are seen on the surface as small white dots, and extend along the pyramids of the medulla, having a great tendency to spread downward along the submucous connective tissue to the ureter and bladder, and to involve also the vesiculæ seminales, prostate, and testes.

Scrofulous kidney is known also as strumous pyelitis, scrofulous pyelonephritis, and the inflammatory form of tubercular disease of the kidney. Masses of cheesy infiltration commence in the substance of the renal papille, and extend deeply into the kidney as well as downward to the submucous tissue in the renal pelvis. The body of the kidney is enlarged, lobulated by the extension of cheesy infiltration into the cortical parts of the organ, and on section conical masses of this cheesy material in different stages of

softening are found to correspond to the prominences of the lobules. The mucous membrane of the renal pelvis and ureter is thickened and at a later period ulcerated and choked up by the putty-like material which exudes. The whole organ may be converted into a huge abscess-cavity or a series of large irregular abscesses. Scrofulous disease sometimes spreads by contact and involves the liver or the spleen.

**Symptoms.**—*Disseminated tuberculosis* of the kidney produces no characteristic symptoms referable to that organ. In the early stages of *strumous pyelitis* the constitutional symptoms are not marked, and the local symptoms are absent. As the disease advances there is pain in the loin, with tenderness on pressure in the lumbar region. The urine may not be altered in quantity or character; or it may be excessive in quantity, in the early stage; and albuminous, alkaline, or acid, sometimes bloody, or containing pus, minute cheesy masses, and débris of renal tissue, in the later stages. When it contains albumen the urine is always thick, cloudy, or opaque, and not clear, as in Bright's disease; moreover, it never contains casts of the renal tubes. Occasionally there is suppression of urine, more or less complete, and then uræmic symptoms usher in the fatal termination. Often a tumor can be felt, or there is a greatly-increased area of renal dulness; and if the disease be on the left side, the spleen may be so much pushed forward as at first sight to give the impression that the tumor is an enlargement of that organ. I have seen this mistake committed more than once.

Vesical irritation and frequent and painful micturition are common and often the most prominent symptoms. In the advanced stages rigors, exhausting sweats, and finally hectic occur.

**Diagnosis.**—Unless a tumor exists, or the characteristic cheesy débris is detected in the urine, it is difficult, if not impossible, by the symptoms alone to distinguish scrofulous disease from pyelitis or pyelo-nephritis from any other cause. In the early stage of the disease the diagnosis from renal calculus must depend chiefly on the physical and constitutional signs of tubercle or scrofula. Often a deposit in the epididymis coexists and determines the diagnosis. In stone there is more hæmaturia and less pyuria; in scrofula there is more pyuria and less hæmaturia. The tubercle-bacillus has been discovered in the urine, and should be looked for.

**Prognosis.**—This is most unfavorable, and the tubercular affection terminates rapidly. The scrofulous form lasts from a few months to a year or more.

**Treatment.**—This consists in alleviating pain and anodynes locally and internally, tonics, cod-liver oil, maltine, and bland nutritious food. When pus is pent up either in the kidney or behind it, it should be drained away through an opening in the loin. Nephrectomy would be useless in tubercular disease, but promises much as a means of prolonging life in scrofulous affection of one kidney alone. In most instances it should be made a subsequent operation to nephrotomy and drainage; but if the strength of the patient would bear the greater operation, and if from the enlarged size and

bossed or nodulated surface of the kidney there was reason to think that the caseous nodules were numerous and large, it would be best to perform nephrectomy at once. To cut into one of several abscess-spaces and to drain it, leaving others unable to discharge their contents, is unsatisfactory in theory and unsuccessful in practice.

The surgeon must, however, bear in mind that it is in scrofulous diseases especially that the probability of the second kidney being likewise diseased is so great; and he must be on his guard against the catastrophe of removing a kidney and losing his patient within a few hours from uræmia due to the destruction of the opposite organ. The chances of such a calamity are much greater when operating on children than on adults, because of the much greater frequency with which both organs are involved in the scrofulous disease in the young than in those past puberty.

#### SOLID TUMORS OF THE KIDNEY.

The solid growths which occur and present themselves as abdominal tumors in the kidney are carcinoma, sarcoma, fibro-fatty (a variety of small-celled) sarcoma, fibro-sarcoma, myo-sarcoma, and lipoma. Other forms of new growth are met with, but have a general rather than a local importance, and, not giving rise to tumors, will not be here considered.

**Definition.**—Malignant renal growths—cancer and sarcoma—may be primary or secondary; but, as the latter growths pass undetected during life and are quite insignificant as compared with the disease to which they are secondary, no further reference to them is required here.

The primary growths usually affect one kidney only, attain considerable—often immense—size, grow rapidly, and destroy life by their own local progress. They are far more often sarcomatous than cancerous.

They occur at two periods of life,—namely, in early childhood and in advanced age. The frequency of sarcomatous tumors in early life is consistent with what is known of tumors of connective-tissue origin in other parts of the body, whereas cancerous growths, being of epithelial type, affect most commonly persons of adult and advanced age.

**Pathology.**—These primary renal tumors of childhood, whether sarcomatous or cancerous, are exceedingly soft in structure and luxuriant in growth. They have been known to reach sixteen or seventeen pounds in weight in six months in children under five years of age; and in a boy in the Middlesex Hospital the tumor weighed thirty-one pounds, the total weight of the child and tumor together being one hundred and thirty-one pounds. Eight or nine pounds is a very common weight for such tumors. Their soft consistence has sometimes led to a renal sarcoma being mistaken during life for ascites.

Primary malignant growths, except the myo-sarcoma, are never bilateral; in the rare instances in which both kidneys have been involved the one is secondarily so to the other. They originate in two situations,—the fibrous stroma of the cortex and the submucous cellular tissue. Sometimes the

renal tissue is invaded by a growth which has had its primary seat in the lymphatic glands or other structure about the hilum, or has begun in the renal tissue of the hilum and spread between gland and pelvis, and after penetrating and expanding the capsule has taken on the form of the kidney. Possibly this latter is the commonest mode of origin in primary renal tumors, and explains why the renal pelvis and proper renal tissue remain long intact and why there is such frequent absence of diseased products in the urine. This mode of origin explains, too, how in many cases an enormous tumor involves and effaces only a part of the kidney, leaving the rest of the organ of natural size and appearance and either situated on the outer surface of the growth or more or less surrounded by it. When the disease commences within the renal capsule it infiltrates the organ very rapidly, and cysts with bloody or purulent collections form within it as the disease advances.

These tumors give rise to secondary growths in other organs by invading the venous and lymphatic channels. The lumbar glands are early involved, then the thoracic duct and venous canals, and by extension the lungs, and later on the liver, bones, periosteum, etc. The opposite kidney, as well as the spinal column and cord, is invaded by contiguity.

All forms of cancer of the kidney are met with, but encephaloid is the most usual and attains the largest size. In some instances the growth is encapsuled.

The sarcomas are usually small and large round-celled varieties, sometimes encapsuled, but more frequently not; they are very vascular, and extravasations, often so extensive as to make the whole look like a mass of blood-clot, frequently take place into them. Spindle-celled sarcoma is less common. The so-called fibrous and fibro-fatty tumors are varieties of sarcoma, the latter having undergone extensive fatty degeneration.

*Rhabdo-myoma* and *myo-sarcoma*, composed of striped muscle and sarcoma tissue, are of congenital origin, and lead to the death of the infant in from six to eight months. In some instances there has been a tumor of each kidney; in some no vestige of normal kidney-structure has remained; in others the tumor has been placed beneath the capsule, but upon the surface of the renal tissue.

**Etiology.**—Renal calculus and injury and the irritation of pyelitis or retention of urine are the most frequent exciting causes. In many cases in children no cause can be attributed. Sometimes a malignant growth is engrafted upon a serous renal cyst.

**Symptoms.**—No distinction can be made between the symptoms of cancerous and those of sarcomatous growths. These symptoms are tumor, pain, hæmaturia, emaciation, loss of strength, irritability of bladder, sallowness of skin, and the effects of pressure upon surrounding organs, such as œdema, constipation, vomiting, jaundice, dyspncea, and interference with the action of the heart. Uræmia is rarely, if ever, a symptom. The existence of a tumor is the most constant sign, and in children this may fill the whole

abdomen, but in other cases deep manipulation of the abdomen, assisted by chloroform to relax the parietal muscles, is needed to make out the swelling. Small tumors in children are felt sometimes by the bimanual method. Renal tumors cause fulness, and when of large size bulge laterally; and, though they do not protrude in the loin, they give rise to fulness, resistance, and roundness in the ilio-costal interval which are obvious to eye and touch. In slighter cases they merely efface the hollow of the loin without producing fulness.

They have bowel in front of them with only the rarest exceptions. The colon is almost never absent from the front of a renal tumor, the ascending colon being in front and towards the inner side of a right renal growth, the descending colon in front of a left. Coils of small bowel also are apt to overlie the front of a tumor of either kidney; but when of very great size, so that they are widely in contact with the abdominal walls, the small intestine may be altogether displaced from off the front of the swelling. The duodenum is usually to the upper and left side of a right renal tumor. An exception to the rule that kidney-tumors have bowel in front of them is when the right colon (which is more loosely connected with the right kidney than the left colon is with the left kidney) is pushed down by the tumor, which then advances between the liver and the ascending colon. Another exception is when the renal tumor carries the colon inward towards or beyond the median line.

Renal as well as hepatic and splenic tumors descend with inspiration.

Malignant growths often spring from or attach themselves to some single part of the kidney, and thus the tumor does not retain the original shape of the organ.

Next to swelling, pain is the most constant symptom of malignant disease of the kidney. The harder the growth the more severe the pain: hence children with very soft growths often seem to be entirely free from it. The pain differs from that due to stone in not being intensified by movements, and in less frequently taking the course of the ureter and testicle. It often extends, when the growth is spreading towards the spinal column, to the lower dorsal and lumbar regions and thence down the thighs. Paralysis of the bladder, sphincter ani, and lower limbs, and bed-sores, are later sequela of this direction of growth.

Hæmaturia occurs in a considerable minority of cases; but in some of these it has been, no doubt, due to the stone which has excited the new growth. When it is caused by ulceration of the tumor into the renal pelvis the bleeding is continuous and constant, not intermittent. It may be profuse enough to cause anæmia and even death. The urine is of a tawny-brown color, with a bloody, powdery sediment; the blood is uniformly mixed with it, and the urine is not more loaded with blood at the end of each micturition. The hæmaturia differs from that of renal calculus in not being diminished by rest in bed for days together. When not admixed with blood the urine is, as a very general rule, quite natural, containing no

casts, no pus, and no cancer-cells. The growth may soften and break down after ulcerating into the colon, duodenum, or ureter, or through the peritoneum or abdominal wall. When either of these events happens, death very quickly follows.

**Prognosis.**—The disease is always fatal, and more rapidly so in children than in adults. The large majority terminate within six months; the rest usually within the first year. Death has been known to occur within six weeks. The softer the growth the quicker the rate of growth and the earlier the end.

**Diagnosis.**—The diagnosis has to be made first as to the seat of the tumor; secondly, as to its malignant nature. Attention to the symptoms mentioned above will serve to establish both these points. The initial situation of the swelling, the direction of increase, and the area of dulness on percussion will help to fix the renal origin as distinct from the liver, spleen, or ovary. Errors in this respect are, however, sometimes quite unavoidable. The rapidity of growth and the unequal resistance of the tumor, its nodular outline, and the progressively cachectic condition of the patient, especially if under five or six years of age, indicate with sufficient clearness the malignant nature of the disease.

**Treatment.**—This is either operative or palliative. Palliative treatment must be thought of only in the middle and later stages of the disease. In the very early stage, when the tumor is small and the lymphatic glands and surrounding parts uninvolved, nephrectomy seems to offer a prospect of prolonging life, and in exceptional cases of securing a permanent cure.

The palliative treatment aims only at relieving pain and checking hemorrhage. Morphine or opium, applied locally and injected subcutaneously or taken by the mouth, will often be required to be used systematically. An ice-bag applied over the tumor gives relief from the burning sensation and the feeling of stretching and bursting often complained of, especially when the increase in growth is rapid. Belladonna plasters and conium poultices afford some degree of relief. Hemorrhage may be sometimes completely arrested by the internal use of gallic acid and ergot combined, by the tannate of aluminium, or by a mixture containing one or two grains or more, according to the age of the patient, of iron alum. The latter drug is specially useful in checking the hemorrhage and the anæmia which goes with it. It is much more effective in bleeding from the kidneys than alum, which is given to children for this purpose in two-grain doses, either as a mixture or with honey or molasses.

#### CYSTS OF THE KIDNEY.

**Definition.**—Cysts within the kidney-tissue and those involving the kidney from without are to be distinguished from hydro-nephrosis, which is a cystiform dilatation of the natural cavity of the organ.

There are only three forms of cysts connected with the kidneys of children,—namely, (a) congenital cystic metamorphosis of the kidneys; (b) para-

nephric cysts; and (c) hydatid cysts. The large solitary cysts which occur in the otherwise healthy kidneys, and which form such striking and often immense tumors in adults, are not met with in the organs of children.

**Pathology.**—(a) Congenital cystic metamorphosis of the kidneys is a fetal condition, the result of obstruction. It is of more interest to the pathologist than to the surgeon. It is similar to the cystic transformation of adult and advanced extra-uterine life, which gives rise to a tumor on each side and to hæmaturia, uræmia, and the characters of urine like those belonging to granular kidney. Like the extra-uterine disease, the intra-uterine is composed of cysts consisting of dilated and intersected tubes containing urinary matters. The fetal transformation is associated generally with absence of ureters or pelvis, or occlusion of other parts of the excretory passages, such as closure of the straight tubes from impaction of uric acid and from intra-uterine nephritis. There are, too, very often associated malformations of other parts of the body, such as club-foot, hernia cerebri, cleft palate, hare-lip, ectropion vesicæ, supernumerary and webbed fingers and toes, etc. The usual consequence of this transformation is the death and expulsion of the fœtus; or the abdominal swelling due to the kidneys may be so extreme as to prevent the expulsion until after embryotomy has been performed. If premature birth before the death of the fœtus should take place, the child dies soon afterwards, from pulmonary embarrassment or marasmus. When only one organ has been involved, the infant has lived as long as nineteen months, a wretched existence, with symptoms of extreme rickets, exhausted by diarrhœa, and dying at length of uræmia or convulsion. In such cases the kidney is not always large enough to present an abdominal swelling, and the condition has not always been suspected during life, but has been discovered unexpectedly at the post-mortem examination.

(b) Paranephric cysts are developed in the perirenal cellulo-fatty tissue, generally posterior to the kidney, with the pelvis or ureter (or both) of which it may communicate. Some of these cysts are congenital, others are due to injury, others, again, are of quite uncertain origin. The attacked kidney is healthy in structure, and the ureter is pervious throughout.

In one recorded case, in a boy aged six years, the cyst held five pints of transparent fluid free from urinary constituents, and there projected into its cavity, from the cyst-wall, at a point five inches from the kidney to which it was attached, a small mass the size of a walnut, which proved to be a perfect single lobule of a third kidney, but without an excretory duct. A prolongation of the cyst passed beneath Poupart's ligament and through the femoral ring.

**Diagnosis.**—Clinically such cases are indistinguishable from hydro-nephrosis and from such paranephric cystic formations as occur after injuries to the kidney. They may be mistaken for hydatid of the kidney and for some of the solid renal tumors. They are to be diagnosed from tumors arising in other parts or organs by the same general characters as

enable us to diagnose other renal tumors as such. The symptoms excited are merely the same local features and pressure-effects caused by other renal tumors.

**Treatment.**—Paranephric cysts require to be treated like hydatid cysts and hydro-nephrosis. They should be tapped and emptied with a trocar and canula, and if they refill again and again they should be opened and drained, through either the coni or the side of the abdomen, according to their position, and the edges of the cyst should be stitched to the edges of the wound in the abdominal parietes.

#### HYDATID OF THE KIDNEY.

**Etiology.**—Hydatid is the cystic stage of the *tænia echinococcus*, an intestinal tape-worm common in the dog and the wolf. This tape-worm consists of four segments, and is about the size of a millet-seed. The last segment is the only fertile one, but this contains four or five thousand ova. The ova taken in water or food into the body of man and many other animals there develop into large cystic tumors, which form the largest parasitic growths to which man is subject.

**Pathology.**—Hydatid cysts grow either in the glandular substance or in the subcapsular cellular tissue of the kidney. The renal substance atrophies in varying degrees, from the pressure exerted by the tumor. Sometimes the whole kidney is destroyed, and the cystic swelling may fill the greater part of the abdominal cavity. Frequently the cyst bursts into the pelvis of the kidney, the ureter, the intestine, or the lung; rarely, if ever, externally. Inflammation and suppuration occasionally attack the cysts; or the tumor may contract and dry up, leaving a putty-like or osseous or cretified mass. Many cysts of different sizes sometimes exist in the same kidney. The left organ is most frequently affected.

**Symptoms.**—Hydatid is the only parasite which forms a renal tumor. The usual period of the disease is after the twenty-fifth year; but it has been found in the fetus, and also as an occasional occurrence in infancy and childhood. Some of the adult patients whose histories have been recorded are known to have been affected—indeed, to have voided hydatids from the kidney—since the first, second, third, or fourth year of life. About one-half the cases of hydatid disease of the kidney form tumors appreciable during life. The tumor is usually globular, more or less fills the coni, varies in size from that of an orange to a mass filling the whole abdomen, is elastic to the feel, and sometimes fluctuating. The relation to intestines and other surrounding parts accords with that of renal tumors generally. In the majority of cases of this disease renal hydatids escape with the urine, and in some cases by the bronchi, stomach, or rectum at the same time as by the urinary passages.

A sense of something giving way and pain in the coni and along the ureter usually precede the escape of the vesicles. Rigors, vomiting, spasmodic colicky pain, and sometimes suppression of urine and retraction of



the testicle accompany their transit along the ureter, which occupies from a few hours to a few days. Then comes a period of relief during their sojourn in the bladder, followed by painful efforts at micturition and by retention of urine until they have completed their journey through the urethra. Whether they burst, or do not, the hydatid cyst may suppurate. Unlike renal calculus, however, suppuration in connection with hydatids never opens externally nor into the peritoneum. The duration of the disease is quite uncertain, recovery being sometimes perfect after one or two discharges of vesicles, whereas in other cases recurrences of the discharge of vesicles have taken place during twenty, thirty, or more years.

**Diagnosis.**—There is no difficulty in the diagnosis when with a tumor in the renal region vesicles, hooklets, or pieces of laminated membrane have been voided with the urine,—except that in some few cases these structures have escaped into the renal pelvis or ureter from a tumor not of the kidney itself, but in its immediate neighborhood. When nothing characteristic passes with the urine the diagnosis from cystic or hydro-nephrotic kidney can scarcely be made. Malignant disease will be told by its very rapid growth and the pain and cachexia it causes. When suppuration occurs in the hydatid cyst the fever and other associated constitutional symptoms may suggest pyonephrosis. The colic of renal calculus is simulated when vesicles travel along the ureter, but the diagnosis is determined by the urine. Aspiration and the examination of the fluid removed clinch the diagnosis when hydatid elements are found in it.

**Prognosis.**—This is generally favorable: in many instances the disease has terminated in cure by the spontaneous evacuation of the cyst-contents; in others, by the withering and drying up of the tumor. When death results it is from suppuration, from suppression of urine, from bronchitis set up by the bursting of the cyst into the bronchi, or from pleurisy or pneumonia due to pressure.

**Treatment.**—Turpentine, iodide of potassium, and the oil of male fern have each been credited with doing good in particular cases, but probably with doubtful reason. Certainly medicines, if not actually useless, are quite unreliable; though when a communication exists between the hydatid cyst and renal pelvis, beverages containing nitre, alkalies, and some of the vermicide drugs have seemed to stimulate the escape of the vesicles.

When the tumor is of large size without a communication with the ureter or renal pelvis, the proper treatment is to cut down upon the cyst, and, having tapped it and emptied it of its contents, to incise its walls and stretch the cut edges to the margins of the skin-wound. The tumor should be opened from the conic if possible; if not, then at its most prominent point. Aspiration may be tried before incision, but is a far less certain measure.

Owing to the frequency with which these cysts empty themselves through the duct of the kidney, and also to the known improbability of their ever bursting into the peritoneum, there is nothing like the same necessity to

evacuate a tumor of the kidney as there is in hydatid of the liver. When the cyst is suppurating and causing much constitutional or local trouble, it should be incised and drained, even though a communication with the renal pelvis has been previously established.

#### INJURIES OF THE KIDNEY.

Injuries which involve the kidneys are of various kinds. They may be conveniently classed under four heads :

1. Subparietal injuries of the kidney.
2. Those in which an open wound communicates with the injured kidney.
3. Prolapse of the *injured* kidney through an external wound.
4. Prolapse of the *uninjured* kidney through an external wound.

The relative frequency of these several forms of injury is shown by the fact that out of two thousand six hundred and ten inspections of persons dying of all kinds of injuries and diseases, there were thirteen cases of injured kidney ; of these, twelve were subparietal injuries and one was a penetrating wound.

**SUBPARIETAL INJURIES.**—These, being by far the most common, will engage the chief part of the space allotted to the subject of injuries.

**Causes.**—The causes of subparietal injuries are falls and blows upon the loin, the abdomen, or the lower part of the thorax ; the forcible bending of the trunk in falling from a height ; and crushes, as in the passage of a carriage-wheel over the belly.

**Pathology.**—The nature of the injury varies much. Most commonly there is more or less laceration of the renal substance ; much less frequently there is complete rupture through the whole organ ; rarely the whole kidney is crushed into a pulp ; and sometimes, on the other hand, the damage is limited to the outer or inner surface of the organ, so that blood is effused beneath the fibrous capsule or into the pelvis without any distinct rupture of the substance, and the source of the bleeding cannot be made out. In the majority of cases blood is extravasated, sometimes in large quantities, into the circumrenal tissue. Occasionally no hæmaturia and no local swelling follow an injury of the kidney for days or a few weeks, and then, as the result perhaps of walking or moving about, severe hæmaturia or sudden and extensive swelling takes place in the loin and abdomen. The later results of injured kidney are pyo-nephrosis, renal abscess, perinephric abscess, hydro-nephrosis, or maybe some *extra-renal* cystic formation filled with urine mixed, or perhaps not mixed, with blood-clot or pus. In these subparietal wounds very frequently some other viscus besides the kidney is injured at the same time ; but often the kidney is the only organ damaged. Occasionally fractured ribs complicate or cause directly the damage to the kidney.

**Symptoms.**—Hæmaturia following an injury to the loin or the front of the ilio-costal area of the abdomen is not necessarily symptomatic of

*ruptured* or *lacerated* kidney; and, on the other hand, hæmaturia is not always a symptom when the kidney is severely lacerated or completely ruptured. If the ureter becomes plugged by clot, so that neither blood nor urine can get down to the bladder from the injured organ, hæmaturia cannot occur, and the kidney may be ultimately lost as an excreting organ. If the cortical substance of the kidney is only superficially lacerated, there need not be even the smallest drop of blood passed with the urine.

1. Hæmaturia may denote simply *contusion of the kidney*.

2. Hæmaturia may arise by simple transudation of blood from a temporarily congested kidney, and without any appreciable breach of surface.

3. When hæmaturia does not occur immediately but only at an interval of some days after an injury, it may be due (*a*) to the displacement of a clot which was formed during the syncope or collapse induced by the injury, or (*b*) to the escape of a clot along the ureter which for a time completely obstructed the passage of urine or blood from the injured organ.

After contusion or laceration of the kidney the quantity of blood passed with the urine during the first few hours sometimes amounts to many ounces. In other cases it is very small in amount at first. In some cases hæmaturia may not appear at all for several days, or, having appeared, may disappear for several days, and then recur on going to stool, or on taking a short ride or drive, or on making some, it may be even slight, muscular effort. Hæmaturia has been absent in cases where the kidney has been completely ruptured in two.

The earliest symptom after the collapse in many cases is pain in the loin or renal area of the abdomen, shooting down perhaps to the testicle, groin, or thigh. Ecchymosis of the loin may or may not be present. The urine may be either partially or entirely suppressed, or simply retained in the bladder. In other cases it is passed naturally. If there are blood-clots in the urine they should be carefully floated out in water and their shape examined: some hint as to the situation of the injury may be acquired thus. There may be severe renal colic from passage of clot along the ureter, or frequent and painful micturition from its presence at the neck of the bladder or in the urethra.

A tumor in the region of the injured kidney is a sign of much importance. In some cases this is formed and rapidly increased in size during the first day or two after the injury; it is then attended with fever, abdominal distention, œdema of the skin of the loin, extreme tenderness, and agonizing pain. In other cases there may be no tumor for many days or weeks, but subsequently a large cystic swelling may develop and not give rise to pain or tenderness until it has attained considerable size.

**Prognosis.**—Contusions and superficial lacerations of the kidneys are very capable of recovery; but complete rupture is pretty nearly sure to cause death from hemorrhage or peritonitis unless the loin is incised, the hemorrhage checked, and perhaps the kidney removed by operation. If the peritoneum is untoned and the renal artery and vein escape laceration,

there is every prospect of recovery from these injuries if properly and promptly treated.

**Diagnosis.**—After an injury to the kidney or ureter symptoms are sometimes absent, or so obscure and insufficient for several days that no damage to the organ can be made out; but after a longer interval hæmaturia may occur or a tumor may form, and then the nature of the injury is made clear. Experience shows that these are very important facts to bear in mind, and should make us watchful before concluding that the kidney is intact.

If, when the collapse from an abdominal injury has passed off, pain in the hypochondriac or lumbar region continues, and there is vomiting, with anxiety of countenance; if, moreover, the urine contains blood and blood-casts, gradually diminishing in quantity, for from three or four to six or seven days or longer, and if convalescence is slow, the suspicion that some contusion or laceration has occurred is justly aroused.

If after the abdomen has been run over, or the child has fallen or been struck on the abdomen or loin, faintness, coldness, vomiting, and abdominal pain follow; if on the day of or the day after the accident, and whether the catheter be required or not, the urine is found to contain a quantity of blood and blood-clot; and if after several days blood-clots continue to pass, or pus as well as blood is voided in the urine; if, moreover, there is pain along the course of the ureter, with retraction of the testis, or a rigid and prominent state of some of the muscles of one side of the abdomen, with frequent desire to micturate; or, finally, if a tumor, dull on percussion, forms in the loin or in the lumbar or hypochondriac region of the abdomen, accompanied or not with signs of local peritonitis, there are safe grounds for believing that either the kidney or its pelvis has been ruptured.

**Treatment.**—Absolute rest in bed, the avoidance of stimulants and solid food, and the alleviation of pain and restlessness by anodynes are all indicated. In all cases the diet must be bland in nature, fluid in character, and limited in quantity.

Pain is sometimes assuaged by strapping the affected side of the body, a practice which also tends to limit and check hemorrhage. Caution must be used in acting on the bowels, as hæmaturia is sometimes excited by an aperient or an enema. The internal use of astringents, especially ergot, may be called for to check hemorrhage, but, with the same object, every precaution must be taken against exciting irritability of the stomach; and if vomiting occurs, food as well as medicine must be given solely by the rectum.

In every case where, from the increasing painfulness, tenderness, and œdema of the loin, it is obvious that extravasation of urine or of urine and blood is going on, also where inflammation and suppuration are threatened and the patient's general condition is becoming more and more critical, lumbar incision ought to be resorted to without delay, and the question of nephrectomy decided by the conditions discovered. In most cases, except for profuse and uncontrollable hemorrhage, it will be best at first to rest

content with free lumbar incision and drainage, reserving nephrectomy for a future time should the subsequent symptoms indicate it.

If at a later period after the injury hydro-nephrosis, pyo-nephrosis, or a renal or perinephric abscess should result, the treatment should be guided on the same principles as those laid down under these different headings.

In certain cases where the continued passing of blood-clots into the bladder leads to cystitis and the gradual wearing out of the patient by pain and painful micturition and fever, cystotomy should be employed and the clots thus removed; but what is far better is, by early lumbar incision, and, if needful, nephrectomy, to put a stop to the hemorrhage and the painful and frequent micturition which is caused by it, and thus also to prevent the onset of cystitis.

**PENETRATING WOUNDS OF THE KIDNEY COMMUNICATING WITH AN EXTERNAL WOUND.**—They may be inflicted either from the loin or through the peritoneum. They cause pain extending to the groin and testicle, difficult micturition, and hæmaturia or the discharge of pure blood along the urethra. Possibly, but by no means necessarily, urine may escape through the external wound. These symptoms, together with the situation, depth, and direction of the wound, leave no doubt, in most cases, as to the nature of the injury. Foreign substances, such as pieces of clothing or bone, may be carried into the kidney, and give rise to great suffering while passing along the ureter to the bladder and thence along the urethra. Penetrating wounds are attended and followed by the same general and local symptoms and pathological changes which have been described under subparietal injuries. Obstinate or permanent urinary fistula is not a common sequel of these wounds.

The prognosis of these wounds is not more grave than that of the contusions and lacerations above described. Wounds which communicate with the peritoneum are more serious than those which do not, on account both of the insidious and dangerous hemorrhage, and of the extent and severity of the inflammation which is apt to be set up either by the injury itself or by the extravasation of urine and blood.

The treatment must be directed on the same lines as that for contusions and lacerations when there is no external wound. In no case should a wound in the loin communicating with the kidney be closed, but left open for free drainage. When the wound traverses the peritoneum it will in all probability involve the bowel or some other viscus. Whether it does so or not, a penetrating wound of the peritoneum, unless the patient is too profoundly collapsed, should be treated by laparotomy, any wound in the intestine should be stitched up, and the peritoneal cavity thoroughly cleansed by irrigating with warm water previously boiled. Whether nephrectomy will be advisable or not will depend on the nature of the injury done to the kidney. If either renal artery or vein is wounded, or the kidney is greatly injured, or a large communication exists between the pelvis of the kidney and the peritoneum, it will be necessary to excise the kidney at once.

Where only the surface of the kidney is wounded and the renal pelvis is not opened, there is little, if any, probability of urinary extravasation, and nephrectomy is not indicated. Where the peritoneum communicates with the renal pelvis, or the ureter, through a small puncture, the opening in the viscus should be closed with sutures.

**PROLAPSE OF THE KIDNEY THROUGH AN EXTERNAL WOUND.**—The kidney may be prolapsed through a wound either in the back, or on the front of the abdomen. When through a posterior wound, the peritoneum need not be injured.

The prolapsed kidney may be either injured or uninjured. The prolapse may take place primarily,—that is, at the time of the infliction of the parietal wound; or secondarily,—that is, some time after the infliction of the wound, as the consequence of coughing, sneezing, or some other considerable muscular effort.

The prolapse may be only partial,—that is, only one end of the kidney may project through the wound, as in the case of a boy, aged fourteen, where the lower end of the right kidney, from which a large piece had been chipped off so as to lay open the cavity of the renal pelvis, projected through a wound just above the crest of the ilium.

The wound through which the prolapsed organ appears may be inflicted by some penetrating or cutting weapon, by a fall, or by gunshot.

When not much injured, the kidney should be replaced if the case is seen before strangulation of the organ has occurred. When the renal artery or vein requires ligaturing, or the organ is considerably pulped or lacerated, the kidney must be removed after ligaturing its pedicle.

If a portion of the prolapsed kidney has been broken off, but the bulk of the organ is not much bruised and the blood-vessels and ureter are intact, the large remnant of kidney should be replaced, with the fair expectation that the wound will close and the damaged organ continue to excrete urine. Such was the case in the boy above referred to, who completely recovered at the end of eight weeks.

# ENURESIS—INCONTINENCE OF URINE.

BY A. JACOBI, M.D.

---

THE incomplete development of the sphincters, in the infant, results in the involuntary emission of urine and discharge of feces. This condition prevails a year or two, and is not attended with any subjective sensation, or sensitiveness. The sphincter ani is the first to gain sufficient strength to retain the contents of the rectum; debilitating diseases occurring in later years may restore it to its original incompetency. The sphincter of the bladder attains a satisfactory power towards the end of the second year. When, however, its infantile condition persists beyond that period, both the urine and the genito-urinary organs being fairly normal, the involuntary emission of urine continues, particularly during sleep (*enuresis nocturna*), not infrequently through the day (*enuresis diurna*), or both in the night and during the day (*enuresis continua*). Many of such cases get well spontaneously about the period of puberty, when the whole genito-urinary apparatus undergoes a rapid development. In some the functional weakness, however, persists long beyond that time. Not long ago I had to relieve the case of a young lady of eighteen who was getting ready to marry. Most cases are observed between the third and the tenth year in both boys and girls, but the majority of the patients between the eleventh and the thirteenth year, also of those who suffer in more advanced years, are males.

The muscular debility of the neck of the bladder and the internal sphincter (in fact, identical organs) is sometimes but a part of a universal muscular incompetency, which is found among different classes of children. Some are slow, dull, and stupid, and lacking in general innervation; others are simply anæmic, ill developed, and generally feeble; there are some whose whole vitality appears to be expended upon their intellectual sphere: they are smart, quick, spirited, excitable, mentally vigorous though easily exhausted; but their muscles are thin, sensitive, and incontinence of urine is frequent. In many such cases the sexual and urinary organs are quite small. There are others, however, who exhibit no parallelism of debility in the urinary muscular apparatus and the muscle-supply of the whole body. In them there may be great muscular general development, and the neck of the bladder alone seems neglected. On the other hand, there may be great muscular power about the sphincter in an otherwise feeble and anæmic body. Thus, no certain rule can be established, and the diagnosis

of the exact condition of things may become quite difficult. Still there is a class of patients in whom the complication of enuresis with general muscular insufficiency is very apparent. Indeed, young men who after moderate venereal excesses suffer much from nocturnal or diurnal seminal emissions (with or without incontinence of urine) are frequently those who have a positive history of incontinence during their childhood. In them the whole muscular apparatus was defective; and the posterior part of the urethra, when narcotized, as it were, during sleep, gives way before the gentlest pressure on the part of the expelling muscle of the bladder.

Insufficient innervation has been alluded to as a cause of incontinence. Children who pass urine while engaged in eager play may suffer either from debility of the sphincter or from want of mental control. Particularly in diseases of the nerve-centres, with sopor and slow mental action, and where the development of the reflex apparatus is slow and defective, the sphincter, which contracts normally while the bladder is filling up, loses its control. Profound sleep is said to promote incontinence; still all children have that profound sleep, and but a small percentage are afflicted with incontinence. Such general constitutional disorders as scrofulosis and rhaehitis have been charged with producing incontinence, but the vast majority of scrofulous and rhaehitical children do not suffer from it. Slow carbonic-acid poisoning is also credited with resulting in incontinence; thus it is that G. W. Major and Ziem explain the incontinence of mouth-breathing children, and E. Bloch the nervous disposition, restless sleep, and vivid dreams in which the peripherous irritation of the expanded bladder is more readily perceived, thus overcoming the resistance of the sphincter.

Diseases of the spinal cord which lead to incontinence are rare in childhood. Tabes with incontinence accompanied by retention is of the very rarest occurrence; nor is spasm of the urethra, with consecutive dribbling while the spasm is passing, at all frequent.

Nor are local causes leading to partial patency of the orifice of the bladder occurrences which have to be taken into frequent account. Only adult age suffers from asymmetric hypertrophy or atrophy of the prostate gland, from foreign bodies, tubercles, ulcerations, and gangrene in the orifice, from fistula after parturition, from want of contractility after dilatation, and from injury after perineal section. It is true that exceptional cases of the latter kind may occur in the young; but, when they do, their histories are known and their results are easily accounted for. In a few instances I have met with polypoid excrescences at the neck of the bladder of very young girls. The removal of these granulations relieved the incontinence of urine.

While a large number of cases of enuresis are merely the results of the persistence of the infantile weakness of the neck, another series of cases depend on the increased reflex irritability of the bladder, complicated or uncomplicated with the above-described incompetency of the sphincter. That increased reflex irritability may depend on the bladder itself, or may have its source outside.



Expansion of the bladder with urine is a frequent cause of nocturnal incontinence. Hence the drinking of large quantities of water or other beverage in the evening must be prohibited. The effect of the urine contained in the bladder becomes the more injurious the more it is loaded with solid constituents. Urates and phosphates in superabundance are the results of large meals, mainly of nitrogenous material, and inadequate assimilation. The copious use of table-salt, and of salines in general, also of chlorate of potassium or chlorate of sodium, increases diuresis. Polyuria from a cause located in a nerve-centre has the same effect on the bladder, and diabetes mellitus operates by both the large amount of urine and the alterations in its chemical composition. Cystitis in all its forms adds to the irritability of the detrusor: it is a frequent cause of incontinence when this makes its appearance in children whose micturition was normal before. Stone in the bladder has the same effect. Phimosi and tight adhesion of the prepuce may produce incontinence, particularly in those boys who are subject to frequent erections. The rest of the urinary organs exhibit the same influence. Thus in every case of enuresis with uncertain diagnosis nephritis, pyelitis, renal calculus, and vaginal catarrh must be searched for. As a result of incontinence of urine the bladder is apt to be very much contracted: it holds but little, and thus what was originally the result of incontinence becomes an additional cause.

Masturbation is not an uncommon cause of incontinence of urine. I believe that my paper on the subject of masturbation and hysteria in infancy and childhood<sup>1</sup> has directed the attention of the profession to the frequency of the habit of masturbation, with all its consequences. Now, in the young the *caput gallinaginis* is quite large, and Cowper's glands and the vesiculæ prostaticæ are sufficiently developed to result in erections. The constant irritation of the part by self-abuse leads to a chronic inflammation of the whole prostatic portion and the neck of the bladder, which is very sensitive. Infants addicted to the habit are very apt to escape for years its consequences as exhibited in somewhat advanced children; these suffer from general malaise, dull headaches, alteration of temper, and somnolence. The genital organs are mostly changed. The external parts—the vulva, the scrotum, and particularly the glans penis—are rather enlarged, and the urine is sometimes alkaline, and often slightly opaque with mucus, leucocytes, and spherical and oval epithelia, sometimes even spermatozoa.

The condition of the rectum must be carefully examined in every case. The plexus pudendus controls both it and the neighboring organs; the pudendal, perineal, and middle and inferior hemorrhoidal nerves are distributed over the lower portion of the bladder and the vagina. Thus a rectal irritation produced by the retention of feces, the presence of a fissure, which is much more frequent in infancy and childhood than is generally sup-

---

<sup>1</sup> American Journal of Obstetrics and Diseases of Women and Children, February and June, 1876.

posed, and the effect of worms (mostly oxyuris) in the lower end of the intestinal tract, are among the more common causes of incontinence.

Serious disorders of the nervous system, such as epilepsy or night-terrors, are also among the causes or complications of incontinence. They, however, and particularly the latter, need not be taken as causes only; in many cases the night-terror is but a result, co-ordinate with incontinence, of some distant, frequently digestive, disorder.

**Treatment.**—The great variety of the causes of incontinence of urine requires tact and discrimination in the selection of remedies. General anemia and muscular debility indicate a diet carefully selected for its nutritiousness and digestibility. Gentle massage of the whole body, sponging with alcohol and water (1 : 6) or with water, and efficient friction with thick towels, sea-bathing, and the use of medicinal roborants, such as iron or arsenious acid, will always prove beneficial. The elixir peps. bism. et strychn. of the National Formulary is a good preparation for use in insufficient gastric digestion, with atony of the stomach; a child of three years may take a teaspoonful three times a day.

Attention must be paid to the capacity of the bladder. In every case, particularly in the evening, the quantity of fluid must be restricted. The sigmoid flexure and the rectum must be empty in the night, and patients should be encouraged to evacuate both bladder and rectum before retiring. After a few hours' sleep the children ought to be taken up and roused sufficiently for both purposes.

Muscular debility of the neck of the bladder (sphincter) requires general and local stimulation. Strychnine or other preparations of nux vomica prove effective to a certain extent by improving both the general innervation and the appetite; in desperate cases an occasional subcutaneous injection into the perineum (gr.  $\frac{1}{40}$ — $\frac{1}{16}$ ) has rendered good service; an ointment of one part of extract of nux vomica in from ten to sixteen parts of fat, introduced into the rectum (size of a coffee or Lima bean) several times daily will also act well and can be continued for some time. The same indication is fulfilled by ergot, the fluid or the solid extract of which may be employed internally. The interrupted electrical current is perhaps the most powerful local stimulant; one of the electrodes must be applied to the perineum, the other to the hypogastrium or the lumbar region. The advice to apply the negative pole to the interior of the urethra or bladder and the positive somewhere externally is bad, because of the danger of urethritis and cystitis.

Whenever there is oxalic acid or sugar or an excess of urates and phosphates in the urine, the source of the disturbance must be attended to. The digestive disorders forming the source of the anomalous condition require a corresponding change in the diet (diminution of nitrogenous food) or correction of the functional disorders of the stomach and liver. Until that object can be accomplished the prognosis is very uncertain. Vesical catarrh, nephritis, and the presence of a calculus in either the kidney or the

bladder have their own indications; the consideration of which, as they are treated in other parts of this volume, is here omitted. The hyperæsthesia of the body of the bladder, complicated or not with catarrh,—it is often found without it,—requires belladonna or its alkaloid. Both belladonna and atropine are tolerated in much larger doses by children, in proportion to their size or age, than by adults. In many cases a single evening dose of extract of belladonna (gr.  $\frac{1}{4}$  -  $\frac{3}{4}$  - 1) or sulphate of atropine (gr.  $\frac{1}{100}$  -  $\frac{1}{75}$ ) answers well, sometimes to an unexpected degree. Bromide of potassium (gr. vi-xxv), camphor (gr. ii-v), extract. humuli fluidum (℞ iv-x), or the elixir humuli of the National Formulary in teaspoonful doses, given at bedtime, answer a similar purpose.

Causes of reflex contraction located in the vagina, penis, or rectum require local correction. Vaginal catarrh is as obstinate because of its inaccessibility as it is frequent. Polypoid excrescences about the vagina or in the urethra (of the female) must be removed; if there be phimosis, circumcision is required. But a great many cases which are presented for that purpose could easily be remedied by gentle dilatation of the prepuce. Firm adhesion of the prepuce requires careful detaching. Intestinal worms must be removed, and the fact remembered that oxyuris has its original seat in the upper part of the colon and the lower part of the ileum, so that rectal injections have but a temporary effect in most cases. Fissure of the rectum, mostly of small size and located posteriorly, requires forcible dilatation, a procedure which demands no time and no anæsthetic, but is very efficient.

Irritability of the neck of the bladder and the prostatic part of the urethra has been treated by Henry Thompson with cauterization by means of a two-per-cent. solution of nitrate of silver. A solution of one part in a thousand of distilled water will be found sufficient, or a solution of one or two parts of tannin or alum in a hundred. Still, it is a better plan to introduce either an elastic catheter or a metal sound into the bladder, every few days, for two or four minutes. A few drops of a solution of cocaine instilled into and distributed in the urethra a few minutes before the insertion of the instrument will in many cases render anæsthesia superfluous.

The latter, however, cannot always be dispensed with. In the case of a girl of three years, with chronic catarrh of the bladder and incontinence, anæsthesia was required a dozen times, for two purposes,—first, to inject a solution of nitrate of silver (1 : 1000) into the bladder, and, secondly, to dilate forcibly, with increasing amounts of water, the organ, which had habituated itself not to hold more than a few drachms of fluid at a time.

Masturbation, which is so frequently the cause of irritation of the prostatic portion, has its own indications. Its cure is by no means easy. Infants can be watched and forcible prevention of self-abuse (mostly by the thighs or hands) exercised; but children of more advanced years require an unusual amount of firmness and supervision. Bodily punishment will avail but little; in the treatment of incontinence from whatsoever cause, nothing.

# VESICAL, URETHRAL, AND PREPUTIAL CALCULI.

By WILLIAM HUNT, M.D.

---

FIFTY to sixty per cent. of cases of stone in the bladder occur in children under sixteen years of age. Many statistical tables from different authorities attest this fact. Elaborate discussions are gone into by some writers as to the relative liability to stone at different ages,—that is, as to the number of cases that exist compared to the number of persons living at a given age. Thus it appears to be developed that stone is relatively more common after sixty than before twenty; but the absolute and practical fact remains, that as many children come under the hands of the surgeon for relief from this distressing and most painful malady as the combined number of adults suffering from the same cause at all ages of their lives.

From this it might be plausibly maintained that the anatomy of the juvenile genito-urinary organs, the pelvis, and the perineum should hold a larger place in the studies of the lithotomist than that of the fully-developed adult, which is universally taken as the standard. The writer does not remember to have seen the perineum of a boy demonstrated to students. It will be seen, as we go on, that independent of facts as to relative size there are real differences as to position and development which it is necessary for the operator to know and to appreciate.

These statements would also seem strongly to support the opinion that heredity enters largely as a factor in the production of stone. That stone is frequently congenital there is no doubt. Langenbeck found calculus in the bladder of a male fetus of six months, thus proving its existence in intra-uterine life. Brendel quotes three cases of stone in the bladder found within two days after birth. Jacobi quotes six cases in forty autopsies of very young children, and he plausibly suggests that the obstinate colics of some infants may be renal in character. There is no doubt that this is sometimes the case; and when relief from colic pains is not obtained by ordinary treatment, special investigation should be directed to the kidneys and bladder. Dr. Arthur V. Meigs has in his possession a calculus removed post mortem from the kidney of a child of six months, a foundling who died of marasmus. The kidney was otherwise, both to the naked eye

and histologically, healthy. The weight of the stone is one and one-fifth grains; size, seven-thirty-seconds by six-thirty-seconds of an inch. There was another stone nearly if not quite as large, which was lost. From what we know of the growth of stone it is fair to assume that these specimens began during foetal life.

Dr. E. L. Keyes, of New York (from whose complete monograph on stone in Ashhurst's "Encyclopædia" I now quote), removed from a boy of nine years, by a successful lithotomy, three stones, weighing collectively nearly two ounces, which the mother said had been diagnosticated at the time of birth of the child. Troiski extracted from the urethra of a male infant one month old a uric-acid stone weighing twenty-five centigrammes and measuring eight millimetres long and five millimetres broad. Dr. T. G. Morton had a case of quite large stone in a child of sixteen months. These cases are sufficient to prove how early calculus may appear, and from literature and experience they could be multiplied to an indefinite extent.

Heredity in general may be explained by the fact that many families for generations live under the same conditions of salubrity or insalubrity, as to place, clothing, food and drink, occupation and habits, and these all exercise potent and similar influences on parents and offspring. Keyes suggests that the apparent regional distribution of stone may have something to do with the above influences, and that as means of travel and locomotion become more common, and are more freely used, centres of its formation may be finally broken up, by reason of more mixed marriages disturbing hereditary tendencies.

Many cases of hereditary stone are reported. Cadge gives in the *Lancet*<sup>1</sup> the case of a woman who had calculus, whose father died after an operation, and whose brother was then suffering from stone. A classical case is that of Clubbe, who thus reports it to the *Lancet* of February 10, 1872 (p. 204):

"There is a man residing in this town, by occupation a fisherman. During the last four or five years I have cut three of his sons for stone, at the respective ages of two, three, and eight. Two of the stones were lithic acid, one apparently lithate of ammonia. The father and mother of these lads always have lithic-acid sediment, often gravel, deposited from their urine. The grandfather passed one stone and the grandmother seven. A great-uncle was cut for stone. There are six uncles and four aunts. They all suffer either from fits of the gravel or from gravelly or sedimentary lithic-acid deposits; and, to finish up with, there is a cousin, an uncle's child, who gets rid of urinary calculi.

"W. H. CLUBBE,

"Surgeon of the Lowestoft Infirmary.

"LOWESTOFT, January 9, 1872."

It is admitted that the urine of infants is richer in uric acid than that of adults. The uric-acid infarctions of Virchow, the urates of sodium and ammonium constituting the grit found in the kidney-tubules of infants, the brown dust on their napkins which is known by the microscope to be mostly formed of uric acid, all point to a congenital or inherited tendency to pro-

<sup>1</sup> January 5, 1884, p. 6.

duce this substance in excess. This excess may be positive or relative,—positive in proportion to all other ingredients, and relative in that other ingredients may be deficient. Thus we can understand the infantile tendency to acid stone, for, while almost any variety of stone may originate in the kidneys, the uric-acid variety, either wholly or as a nucleus, predominates to such an extent as to constitute, according to the best authorities, from two-thirds to five-sixths of all calculi, these authorities taking the nucleus as the most scientific basis of classification. In this view other deposits, except perhaps that of the oxalate of lime, however large in bulk, may be regarded as secondary, the accretions mostly being deposited after the nucleus has descended into the bladder. Thus, uric acid, the urates of sodium and ammonium, and the oxalates constitute most of the beginnings of stone in children as well as in adults. Their bulk may be largely increased by other deposits, notably of the phosphates. Pure or almost pure phosphatic vesical and prostatic stones, there is reason to believe, have their origin in the places where they are found, and they are mostly peculiar to adults.

A certain amount of cementing matter is necessary to the formation of calculus. The distinction between it and gravel is that the latter preserves its mineral character, while the former is modified both in shape and consistency by the admixture of organic material. These colloids, as they are called, are derived from the albumins and mucus, and exercise most important physiological functions, but, following the law of irritation, they form in excess at the irritating point and make abnormal combinations. The irritant, in the shape of microscopic crystals, or sand, appears in the kidney-tubules, colloidal cement is poured out, and the formation of calculus begins.

But this process is not a mere chance mixture, either as to quantity or as to form. Dr. William M. Ord, in his work "On the Influence of Colloids upon Crystalline Form and Cohesion," proves that it goes on under fixed laws; and he further says that "the pebbles of the concrete would not hold together without the cement to bind them, and act on their surfaces. To make calculi of uric acid without colloids would be as hopeless a task as making ropes of sea-sand."<sup>1</sup>

Calculus is most common at the two ends of life: young people and old people are most subject to it. There is a similarity in the pathological and anatomical conditions of both to favor its production.

It occurs much oftener in boys than in girls, and in men than in women. There is no reason whatever that the original elements of stone-formation should not be the same in both sexes, but females get rid of these by natural, short, and free drainage from the bladder.

On the other hand, boy infants often have abnormally long and adherent prepuces with very fine openings, and there also may be a urethra of small calibre especially at the meatus. Any physician who has noticed

---

<sup>1</sup> Ed. 1879, p. 61, London.

children thus afflicted must also have noticed their strainings when trying to pass water. I remember seeing one case where the pressure was so great and the opening so fine that a minute stream was projected twenty feet. The suffering is sometimes great, and there is this very natural action on the part of the baby. So soon as he feels relief he stops. He does not empty his bladder, and thus he has more or less residual urine always in it. And so, the other conditions being present, the formation of stone is favored, just as it is in the old man whose residual urine results from the mechanical obstruction of a large prostate and an atonic bladder. Once a man, twice a child, is illustrated in more ways than one.

If this view is true, Jewish children, who are circumcised on the eighth day after birth, should not be nearly so liable to stone in the bladder as the children of the uncircumcised. I have made some inquiries on this point. The answers from different quarters have been only partly received. So far, they seem to sustain the view that the Jewish child is remarkably exempt from stone, but sufficient replies have not yet been obtained to warrant a conclusion in time for this article. When received, they will be made the subject of a special note.

It is not the purpose of this paper to enter into a description, both chemical and microscopical, of the different kinds of urinary calculi. This has been so thoroughly done by chemical experts, of whom the writer is not one, that it is not necessary to reproduce an account of their work here. We have given a brief abstract of the present knowledge of the origin of stone, have shown that it may be and often is congenital and hereditary, that sex influences it to a very great extent, the proportion of females to males who have it in the bladder being as five to one hundred, and the cause for this difference we have indicated to be anatomical rather than constitutional.

Occupation can scarcely enter into the consideration of stone in children. Social conditions and habits may have something to do with it. It is known that the poor, and especially the children of the poor, furnish by far the greater number of stone cases. Sir Henry Thompson says, "So common is stone in the children of the poor, comparatively speaking, that at Guy's Hospital, surrounded as it is by a very large neighborhood densely populated by some of the worst classes of the community, quite one-half of the cases admitted are children."

Mastin, speaking of age, and of the abundant supply of uric acid in infants, says that "this condition is doubtless the result of the rapid changes to which they are exposed only a few hours after birth, cold, light, and deficient or improper nourishment tending to disarrange the proper performance of the functions of their various organs. Taking into consideration their defective digestion, errors in their diet, the irritations of dentition, with the consequent excitement of the brain and nerve-centres, we find them in the pathological condition most favorable to the formation of a diathesis which, when acted upon by hereditary influences, will produce these deposits."

Poverty, then, with its surroundings favoring mal-assimilation, does its part in the production of stone, but gout is acknowledged to be allied to those conditions which produce calculi. Sir Henry Thompson says, speaking of stone, that "either gout or calculi will be traced in the family of nearly every patient who presents himself for treatment." Gout is said to be a disease of the rich and well-to-do. If this is so and the conditions are akin, it is curious that they should manifest themselves early in life in the form of calculous disease among the poor and later in life among the rich as gout. Are the healthful surroundings of the gouty man's child sufficient to eliminate his infantile tendencies to calculus? I am strongly of the opinion that, if the child has the elements of calculus deposited within him at birth, he will go on and become a victim of stone, in spite of his surroundings.

The poor vastly outnumber the rich. They are forced to public charities for relief, whilst the relative number of cases of almost any disease among the rich is a matter of conjecture.

The geographical distribution of stone and its race-affinities are most interesting studies. We must refer the reader to the various works and papers upon these themes. Thompson, Gross, Keyes, Mastin, and many others have written about them. We here repeat our opening remark more at large, and say, in passing, that wherever calculous disease exists, whether in China or India, in Europe or America, there infancy, childhood, and adolescence are bearing more than one-half of the sufferings and disabilities that it inflicts upon the human race.

#### THE ANATOMY.

The regional anatomy of the floor or outlet of the male adult pelvis is usually taken as the standard for beginning the study of those parts which are concerned in the various operations for stone in the bladder.

As the surgeon necessarily begins his work from without, this is as good a technical method as any other. It seems to the writer, however, that a much more philosophical and comprehensive understanding of the matter is to be had by studying the parts from within outward, not only with reference to their relations to other parts, but also as to their development.

The reader is referred to the short but admirable description, by Dr. George McClellan, in the first volume of this work, on the Anatomy of Children.

The urinary bladder, developed from a portion of the allantois which remains in the abdomen in early fetal life, is really an abdominal organ, absolutely at first, and more or less so during the whole period of childhood. The bladder therefore may be said to grow and to change its place from above downward until finally, at a time approaching puberty, it is fairly, though loosely, fixed, and hidden when empty, in the pelvis.

In the fetus it may be said that there is no pelvis capable of holding



it; in the infant the obliquity of the pelvis is so great as to form no part of its environment. The relative alterations of the pelvis to the rest of the trunk which sitting, standing, and walking effect bring it partially up to the bladder, which also may be said to descend and gradually to become attached behind the symphysis. The firmness of this attachment increases with age, and has an important bearing upon operative proceedings. (See Figs. 13, 22, and 30, pp. 20, 27, and 38, vol. i., for illustrations of these remarks.)

In contrast with these illustrations, the practical anatomist knows that the empty bladder is not seen on opening the abdomen of an adult in the ordinary way, either in performing a laparotomy on a living subject or in dissecting a dead one. It has to be looked for where its anterior and posterior walls are in contact behind the symphysis. I have frequently seen fresh students in the dissecting-room looking in vain for the bladder. The bladder in anatomical and surgical drawings is always represented as more or less distended, and this is correct, for its natural physiological conditions as to size are constantly varying. The same is true as to preparations, whether natural or artificial: so that it is incumbent upon the student of the surgical anatomy of this region to make due allowance for these constant changes of relation of the parts. The bladder itself may be so distended as to reach high in the abdomen, and it may be almost completely displaced by diseased or artificial distention of the rectum or by enlargements of the uterus of whatever kind. (See Fig. 3.)

FIG. 1.

FIG. 2.

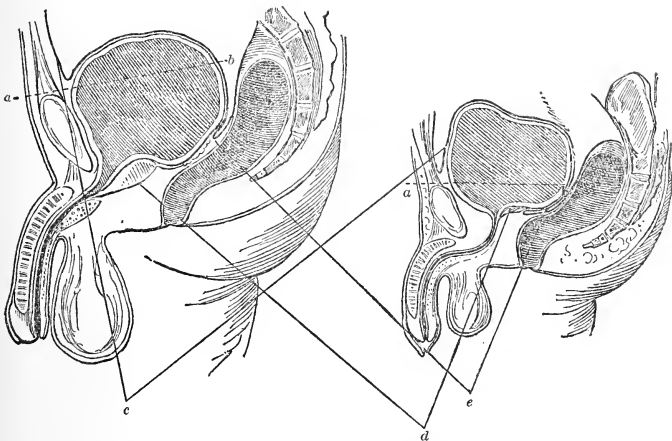

CONTRAST BETWEEN PELVIC CONTENTS OF AN ADULT MALE AND THOSE OF A MALE CHILD OF ABOUT SEVEN YEARS.—c, anterior folds of peritoneum; d, prostate; e, posterior folds of peritoneum.

Figs. 1 and 2 represent the contrast in position between the pelvic contents of the adult male and those of the male child of about seven years.

They were taken from a sketch, made by myself, of two beautifully preserved frozen sections, in St. Thomas's Hospital, London, which I saw through the kindness of Sir William MacCormac and Mr. Reid. The points of importance in relation to the operations for stone are seen distinctly. I know of no preparations concerning this operation that are more instructive. Above the pubis we have the anterior reflection of the peritoneum from the abdominal walls to the bladder, to which, at this point particularly, it is loosely bound by connective tissue. We can understand how upon distention of the bladder it may be readily pushed, or rolled up, as some say, to a considerable distance above the pubis, amply sufficient in the high operation without wounding it to gain access to the bladder for the removal of large calculi.

The peritoneum is more adherent to the bladder on the fundus, and also posteriorly, where it forms the vesico-rectal fold, which in the child is lower than in the adult and even partially covers the rudimentary prostate gland. We can understand how, in the lateral operation upon children from infancy to ten years of age, the whole of the small prostate is almost necessarily divided, notwithstanding the traditional cautions that are given against doing it. The relations of the rectum are well shown, and the possibility of wounding it in perineal operations may be readily appreciated.

Coming forward, we notice the ischio-rectal space (not shaded), a part more concerned in the accidents and failures of lithotomy than any other. The differences in the curves of the urethra owing to the positions of the bladder are seen. Notice by the lines *ab* (Figs. 1 and 2) that at least two-thirds of the young bladder when moderately distended are above the upper margin of the pubis, whereas two-thirds of the adult bladder are below the same level when distended to about a proportionate degree.

We now come to the bony margins of the outlet of the pelvis, which give attachments to fasciæ and muscles which, together with a varying proportion of fat and the skin with accompanying nerves and vessels, form the perineum or pelvic floor.

The anterior portion of the outlet, bounded by the ischiatic tuberosities behind and the lower margin or angle of the pubic symphysis in front, includes the perineum proper and the parts concerned in the perineal operations for stone. Sometimes the part between the anus and the sacrum is called the posterior perineum.

The deep fascia of the perineum, or the triangular ligament, much more pliable in the child than in the adult, fills the pubic arch below the symphysis and between the descending rami of the pubis as far back as the ischiatic tuberosities. It is here reflected forward around the lower borders of the transverse perineal muscles and becomes continuous with the deep layer of the superficial fascia.

The transverse muscles enveloped by these layers of fascia pass inward and forward from their attachment to the ischia to the perineal centre in front of the anus. The deep layer of superficial fascia is also attached to

the anterior margins of the bony rami and symphysis in such a way as to cover the accelerator urinæ muscles in the middle of the space and the erectors of the penis at the sides.

The triangular ligament is perforated for the passage of the urethra, which here is called the membranous portion, and is so called until it is hidden in the bulb of the spongy body of the penis. It is this portion of the urethra in which the operator should feel the staff in the perineal operations for stone.

The anterior portion of the levator ani muscle passes downward and forward to the side of the prostate and is attached to the perineal centre. Mostly some of its fibres are divided in the performance of the lateral operation.

The superficial layer of the superficial fascia, mingled with varying proportions of fat, and the skin, bring us to the external surface of the perineum. While the muscles to the front of the perineal centre are covered with the fascias above described, the sphincter ani is subcutaneous. The junction of the deep and superficial fascias in front of the anus prevents urinary infiltrations, or abscess, from passing backward, and directs them forward and upward. The skin of the perineum is thin and pliable, especially so in children.

The arteries concerned in perineal lithotomy are the internal pudic artery, which is very rarely divided, and the bulbar artery, which is derived from it and which supplies the bulb and spongy portion of the urethra. This may be a source of troublesome hemorrhage. The transverse perineal artery, also coming from the pudic, is nearly always divided, and is easily controlled. The bulbar artery lies between the layers of the triangular ligament, as also do plexuses of veins, which may bleed so as to require special attention.

In the female, both adult and child, so far as operations for stone are concerned, the anatomy of the perineum does not come into consideration, as access to the bladder is had through the short urethra, or by the vagina, or by the high operation.

The anatomy of the high operation is the same in both sexes, and comprises a knowledge of the relations of the abdominal walls to the bladder in the hypogastric region, which will be detailed in the description of the operation. It is to be especially remembered that as to space the above account of the normal anatomy of the outlet of the pelvis is simply to be taken as a guide. Whilst in the adult measurements are fairly regular, in the child they are not only varying quantities according to age, but they also differ exceedingly in children of the same age. Thus, among forty measurements by Velpeau in young subjects, he found the tuber ischii in one case one and three-fourths inches apart, and in another four inches apart. There were many variations between these extremes. Some measurements which I made gave the same irregular results. It is not only the bones that vary, but all the growing tissues. For example, the muscles

in an infant or a young child may scarcely be recognized. The lesson learned is that questions of space, both as to breadth and depth, must be determined by the skill and tact of the operator in the individual case.

This topographical account, the writer thinks, is all that is required here. For the descriptive or special anatomy of the parts the reader is referred to the works of Leidy, Gray, etc.

#### SYMPTOMS.

If the child has had from birth manifestations of the lithic-acid diathesis, as shown in stained diapers and obstinate colics, these will greatly aid in a true interpretation of what is apt to follow as he grows older.

Unfortunately, as most of the children with stone belong to the poorer and ignorant classes, it is rarely that one gets an intelligent early history. They are put through routine domestic treatment for colics, worms, bowel-complaints, and whatever else the wisdom of ignorance suggests. Even the medical attendant, where there is one, may not have his suspicions aroused for some time.

Facial expression is important. A child with stone is not a jolly, laughing child. Even in the intervals of suffering, however playful he may be, there are marks of distress in his face that do not belong to his fellows. He looks old. Mostly there is mal-assimilation and he is thinner than he should be; but sometimes, and especially early in the case, nutrition does not seem to be much interfered with. The local symptoms become more and more marked. There is growing frequent desire to pass water, and this is done with much straining and pain. The pain seems to be greatest as the last few drops of urine are passed out, and is thought to be due to the stone being compressed at the neck of the bladder. If there are mucus, pus, and blood in the urine at this early stage of life, they are almost pathognomonic. Pain is also felt at the end of the penis, and, whether from nervous transfer or from irritating urine, it makes the patient press the glans and pull at the prepuce. Unnatural handling of the privates, particularly in these parts, is a very constant symptom.

The reflexes from these irritations are also marked, and exhibit themselves locally, especially in the scrotum, but sometimes they may extend to all parts of the body. Dr. John H. Packard has recently had in the Pennsylvania Hospital a boy aged eight years who every fifteen minutes had general convulsions without loss of consciousness. He was brought in without any suspicion on the part of his relatives of the existence of a stone. Sounding revealed its presence, and upon its removal the reflex phenomena entirely disappeared.

A child with stone often takes peculiar positions to empty his bladder. He learns by experience the easiest way. Sometimes he will lie on his back, sometimes on one side or the other, sometimes he will support himself on the hands and feet. Again, he will raise his pelvis in some way, and cases are spoken of where the patient has nearly if not quite stood on his head.

The explanation of these positions is reasonable: they are supposed to cause the stone to fall away from the neck of the bladder.

Another common symptom is prolapsus of the rectum, with or without coincident evacuation of feces. There is not often a case without this occurring with more or less frequency.

Urination almost always brings it on, and it may be so prominent as for a time to mask the real difficulty, the "putting up of the body," as it is called, being the frequent occupation of the mother or nurse, and often with the infliction of much pain. Whenever prolapse of the rectum occurs often in a child, stone in the bladder should be suspected as a possible cause, and the bladder should be searched.

Tenesmus is a common symptom, and there may be obstinate incontinence of urine.

What has been so far related pertains not only to very young children, but also to youth and in a great measure to the adult. The difference is that, as advance in years goes on and intelligence increases, the patient himself becomes more accurate in localizing and describing his sufferings. Although sometimes ignorance to a most remarkable degree exists as to the true cause of them, there is mostly some suspicion of the truth.

Moreover, every one of the above-related symptoms may be present and yet there may be no stone in the bladder. There may be stone, but it may be in the kidney or in the prepuce. Cystitis, not so common in the child as in the adult, may give rise to the symptoms detailed. Rectal troubles, prolapse from various irritations, as from ulceration and ascariides, may by reflex affect the functions of the bladder, apparently as seriously as though it were the principal organ involved. Disease of the kidneys and obstructions of various kinds are possibilities which may bring on excessive irritations resembling those of stone. Phimosis with adherent prepuce and irritating smegma may produce analogous symptoms.

#### DIAGNOSIS.

The diagnosis is to be made by the sound. It would be strange indeed to meet with a child having *all* of the above symptoms and find no stone upon sounding, yet this has happened. It is this possibility that makes sounding the crucial test of the presence of stone, and the conditions of this test are that the stone must be both *felt* and *heard*. The last condition is what gives name to the proceeding.

The projecting sacrum and the tuberosities of the ischia may be felt, but they will transfer no sound-vibrations through the instrument used, or at least no characteristic ones. The sensation is that of a dull thud and a fixity of the object impinged upon. A rugous bladder, or one with phosphatic deposit on its walls, is more likely to deceive, but the clear ring of most stones would also be wanting here.

Foreign bodies, which require the same process to ascertain their presence, differ as to the sound emitted by them according to their material.

Very young children may be excluded from consideration as to these objects, but boys and girls are known to have done strange things, or to have had strange things done to them, by the introduction of foreign bodies into the bladder. Glass tubes, pieces of wood, bodkins, crochet-needles, hair-pins, etc., have been passed into the urethra and have slipped into the bladder after escaping from the hands that held them. Pieces of broken catheter, not uncommon in adults, would scarcely be looked for in a young person. These different objects would, of course, influence sound. If long enough in the bladder, they form nuclei for stone, and then impart the sensations of stone. If a foreign body is the cause of the trouble, children suffering in this way are old enough to tell about it, but they mostly will not do so if they can help it. I know of a boy who bore untold pain for four years before he would tell that he had a piece of glass tube in his bladder. Sounding at once revealed its presence, and he was successfully cut as for stone. The writer has seen or had under care all of the above kinds of strange cases.

The process, then, is called sounding, and the name of the steel instrument is the sound.

Much judgment is required in selecting the proper size and shape of sounds, especially for children. By referring to the anatomical plates it will be seen that the child should be examined with one of shorter curve than that used for the adult. A great and dangerous fault of many sounds of the shops is that they are not blunt enough at the points. In fact, it is a good plan to have sounds narrower in the shaft than at the point, for if made in this way the shaft is not grasped by the walls of the urethra so tightly as to interfere with the delicacy of the movements, or of the sensations expected from the part which is in the bladder. Sir Henry Thompson's "searcher" is one of the best forms of sound.

Unless there are valid objections in the special case, sounding should always be done with the patient under anæsthesia.

The argument that if anything untoward should happen the child will express it by pain if he is not anæsthetized, has no weight in comparison with the real danger of damage that he may inflict on himself by his struggles. Violent spasm of his muscles and his cries may render the examination futile both as to feeling and as to hearing, and sudden and unlooked-for movements may cause great damage while the instrument is on its passage to the bladder, even although it be in the hands of the most experienced operator. Our fathers got on without ether, but they must have had a hard time.

The patient should lie on a bed or table, and pillows should be at hand to use in changing the position of the pelvis. A very young child may be held in the nurse's lap, but this is not advisable, as there are few nurses who could hold with the requisite steadiness. Sometimes a trustworthy and intelligent one may, by holding the child, move it into various positions if there is any difficulty in finding the stone.

The sound, being well oiled and warm, is held lightly but securely by

the handle, and the surgeon should allow it to glide along the upper surface of the urethra, using little or no pushing force. Obstacles, so common in the adult, are not often present in the child, and, if one is mindful of the anatomy of the parts, there is rarely any difficulty in introducing the instrument.

Should a moderate-sized or large stone be present, it is mostly struck and heard at once, and its looseness in the bladder is recognized. It is not only heard and felt, but it is also felt to move, and may be made to rattle against the sound. So positive are these sensations to an experienced examiner, and, I may say, often to one of no special experience, that the nature of the case is determined, and it is unnecessary to do any more in this direction.

Size, influencing the choice of operation, may be estimated by tact, or by measurement, but the fact remains that the stone is there and that a surgical operation is necessary for its removal.

But the diagnosis is not always accomplished with this ease. The stone may be very small and escape detection, until, the symptoms continuing, frequent examinations are requisite for absolute certainty of its presence. It may be struck at one time and not at another. It is extremely rare to find an encysted stone in a child or youth. One might be sacculated in a bladder of abnormal formation. In the young there is practically no prostate for it to rest behind in the base of the bladder. Again, the stone may be so covered with organic products as to prevent it from giving the usual sensation, and the sound may glide over it and even push it about without recognition by the examiner.

Under any or all of these circumstances, careful search is to be made in all directions with the point of the sound, and aid may be obtained by passing the finger into the rectum and pushing up the bladder, although this is not in children so often as good a help as it is in the adult.

Various positions may be tried, and a youngster may easily be held in them by a good nurse. The bladder may be injected with tepid water, in view of the fact that the stone may be held in its relaxed folds.

It is the history of stone, both in adult and in child, that one surgeon may detect it and another of equal experience miss it. The certain cases are so easy and the doubtful ones so hard: to say that a thing is, is a much lighter task than to say that it is not.

The practical bearing of these remarks is illustrated by the following quotation from Mr. T. Holmes. "It must be admitted, however, that the diagnosis of stone by the sound is not so easy but that experienced surgeons are often misled. I have seen the bladder opened in a child by one of the best and most experienced surgeons in London, where no stone was detected. Mr. Paget, of Leicester, has had the candor to publish a case of the kind in his own practice. I myself once opened the bladder, and the stone certainly escaped our view; but, as in that case I did not rely on my own judgment exclusively, and as those who assisted me heard as well as felt the stone

immediately before the operation, I think I am justified in saying that there must have been a small stone which gushed out with the urine and was lost. In another case a child was put under my care by a surgeon of much experience in stone, and who had sounded the child as a case for immediate operation, in whom I could detect no stone; who died of another disease, and who was then proved to have no stone in the bladder."

The writer can confirm the above statements, for he knows of and has seen like cases in the hands of the best operators.

What has been said pertains to sounding when there is no question about the instrument being in the bladder. What must be the difficulties when one of the possible accidents occurs in the introduction of the sound!

The loosely-attached bladder of a child may be pushed before it. In this case the stone may be felt through the intervening tissues, but it will not be *heard*. It may be diagnosed as one covered with organic deposit. If the staff follows in the same course and the operation is proceeded with, it will be a failure unless the true state of affairs is recognized before the final steps are taken. There is nothing imaginary in this description. Experiences of the kind are on record.

Another accident is that of breaking through the delicate urethra of the child immediately anterior to its undeveloped prostate. There is naturally here but slight resistance to the push of an instrument in the wrong direction. Hence the injunction to press along the upper wall of the urethra if there is any necessity of pressing at all. No words can give an appreciation of the effects of this accident so well as a close examination of the cut on page 601. It will be seen that the sound at once enters the ischio-rectal space, where in the extremely loose and unresisting tissues of a child it may be moved about almost as freely as if it were in the bladder. There is nothing imaginary in this, either: it is something that has occurred and may readily occur.

These observations in reference to the sound apply to all other instruments that are used for entrance into the bladder through the urethra,—*e.g.*, ordinary catheters, injecting, washing, and evacuating catheters, staffs, lithotrites, and tubes or probes of any kind. We shall therefore not waste space in detailing them again when describing the various operations for the relief of stone.

#### OPERATIONS.

It having been determined that there is a stone in the bladder, a surgical operation of some kind is essential for its removal.

We may dismiss at once all thoughts of treating children by different waters and nostrums in the hope of dissolving the stone. To do this would be to prolong suffering without any gain, for the object would not be attained.

The operations are divided into cutting operations, and crushing or non-cutting ones. The cutting ones are the lithotomies, and are divided into the perineal or low and the supra-pubic or high operations.



The crushing ones are lithotrity, which consists in crushing the stone with an instrument called a lithotrite, the patient afterwards passing the fragments through the urethra along with his urine, and litholapaxy, which consists in not only crushing the stone but also immediately removing the fragments in a current of water set up by the use of a suction apparatus, the patient being under prolonged anaesthesia. It was an essential of original litholapaxy to finish the business at one sitting; but this rule is not so strongly in force as it used to be, for experience has taught that there is such a thing as keeping the patient too long under the operation.

**CUTTING OPERATIONS.**—Two of the perineal operations are performed upon children,—the lateral and the median. To do any other than one of these is so exceptional as scarcely to require notice: so that our attention will be given to describing them. All that is possible in a bilateral operation upon children may be accomplished, if found necessary, during the progress of the median incisions.

The recto-vesical operation may be dismissed from consideration, for the writer can conceive of no case of very large stone in which the present methods of performing the high operation do not entitle it to the first choice.

Of lateral and median lithotomy the former has the preference of most surgeons in by far the greater number of cases. Up to the present time it would be difficult, without special cause, to induce them to depart from it, particularly in children. It may be fairly challenged whether there is any other capital operation in surgery that gives such a measure of success in young subjects.

It may be as well to state here, once for all, that all the operations are to be performed *antiseptically*. While, on account of the functions of the parts concerned, absolute antiseptics can scarcely be attained, it can be so in a great measure. The preparation of the skin, the use of solutions, or of hot water, at the choice of the operator, strict cleanliness, and non-interference of any one but those immediately concerned in the manipulations, are to be as carefully observed as in any other operation. The writer thinks, in reference to operations in general, that the time has arrived to regard this matter as axiomatic, and that its constant repetition in the reports of every proceeding in surgery is excessively tiresome and unnecessary. Antiseptics has come to stay, whatever alterations (and already there have been many) may be made in the details. At the same time he must protest against the tone of much of the teaching of the day, which seems at least to despise the idea of danger in any operation provided strict antiseptics is observed. We shall find, up to date, that lithotomy, like most other operations, still has its record of mortality.

**Lateral Lithotomy.**—When the lateral operation for stone goes on from beginning to end without mishap, the novice must be impressed with its extraordinary simplicity, and he must wonder at the necessity of dissecting so much, hearing so much, and reading so much about it.

He will soon learn that this is the only way, together with practice, by which the skill comes. In illustration, a case may be quoted which was in the hands of that great operator, Dr. Joseph Pancoast, at the Jefferson Medical College. I had a seat on the students' benches; the operator had taken up his knife,—when at that moment a student on the raised bench behind me rubbed his shoe on my shoulder. I turned for a few seconds to remonstrate, and when I looked again at the operator the stone was in his hand. I had seen nothing of the operation.

But the operation as to time and incident varies by wide extremes. Sometimes the patient may be an hour or more on the table before the stone is extracted, and sometimes there is no stone at all, or it cannot be found. I have been present on such occasions. They are well known in the history of lithotomy, and may happen to the skilled as well as to the unskilled.

For a straightforward, uneventful operation very few instruments are required. The sound having been already used, a staff, a knife, and a forceps are all that are absolutely necessary. The operator may get through without using anything else.

But this is not likely, so other things should be at hand: a syringe or a washing-bottle and a catheter if it should be deemed advisable to inject the bladder before or to wash it out after the operation; a scoop, small for a child, if it should be required to move fragments of stone and débris should the stone break; of course a tenaculum, hæmostatic forceps, and ligatures to control hemorrhage; various-shaped forceps if the simple one at first selected should not suit. The writer has extracted a stone from a small child with a polypus forceps or an ordinary dressing forceps. For special use there should be a probe-pointed knife and a blunt gorget, although I have never had occasion to use the latter or to see it used by others.

Care should be taken that the child's bowels are well moved on the morning of the operation. For lateral lithotomy the patient lies on his back, with his buttocks well brought down to the end of the table. This should be firm and not too high. An ordinary kitchen-table is as good as any other, probably better and firmer than many operating-tables with much movable rigging about them. It is well to have the perineum shaved beforehand if there is any hair, and always well cleaned. The child should also be etherized before being brought into the room, as the shock of fright is thus spared him.

It is unnecessary to use anklets or bandages to tie the hands and feet together. A good assistant on each side can easily keep the limbs in the proper position. They are to be held widely apart, with the legs in extreme flexion, the thigh flexed and away from the body and the leg upon the thigh. If the patient is large enough, the knee may be held in the axilla of the holder, whose hands at the same time grasp the ankle. The hands of the patient may require attention, but this is not likely if the anaesthesia is as profound as it should be.

The necessary assistants are the staff-holder, the two holders of the

limbs, and the etherizer. These should absolutely have nothing else to attend to but their specific duties. A nurse, for general duties as required, should be present. The instruments are to be placed within easy reach of the operator. The bare perineum of the patient should be exposed to a good light.

If at the discretion of the surgeon any water or solution is to be thrown into the bladder, it is to be done now.

All the preliminaries as to diagnosis having been previously gone through, it is unnecessary to introduce the sounds again. But the staff itself must be used as a sound. The staff-holder or the surgeon may introduce it, but the latter should at once use it to satisfy himself and his colleagues that the stone is present. If he cannot do so, the rule is to stop proceedings for that time. The stone may have been small enough to have escaped from the bladder since the last examination, or the conclusions from that examination may not have been right. A small stone could readily pass through the dilated and yielding urethra of a child after a good sounding, and be lost or unnoticed by his nurse. If once engaged in the grasp of the urethra at the neck of the bladder, he has an immense pushing power to drive it through. Instances of this kind are on record.

The surgeon should examine the rectum, to be sure it is empty, and, having satisfied himself of the presence of the stone, he fixes the staff in the position in which he wishes it to be held, generally, in a child, hooked well up against the pubic arch; and he abandons it to the staff-holder, who stands mostly upon the left side of the patient, and who can thus more easily use his left hand to hold the scrotum out of the way, should this be required.

The surgeon, as he chooses, may stand, sit, or kneel on one knee. The sitting posture is usually preferred. The first incision is made through the left side of the perineum, beginning at the raphé, half-way between the scrotum and the anus. Exact measurements cannot be laid down as to the point of beginning or as to the length of the incision. In a very young child the latter may not be longer than from three-fourths of an inch to an inch; in a boy of eight or ten it may be from one and a half to two inches in length. We may judge of the variations when in a fully-developed adult an incision of four and a half inches may be obtained. The incision is oblique, and the low point given for its termination is half-way between the tuberosity of the ischium and the anus. However, many operators have no fear of free external incisions, rather thinking that they are more beneficial than not; and so the matter must be left to individual judgment.

The skin, the superficial layer of fascia, and the fat having been divided, the operator proceeds steadily on, but with more care. He deepens the middle part of the wound, cutting inward and rather upward; at the same time he follows the knife with his left index finger, for two purposes,—one to feel for the staff in the membranous portion of the urethra, and the other to press the rectum away from the knife. The parts divided at this stage

are the transverse muscle, possibly some fibres of the levator ani, the deep layer of superficial fascia, connective tissue, and fat. The staff, covered by the membranous urethra, should now be felt without much search. It is well from the beginning for the operator to have his mind fixed upon a point just under the pubic arch against which the staff is held.

The distance of the staff from the surface varies according to age and the amount of fat, so that a young child may have a much deeper perineum than an older one. A depth of about a quarter of an inch from the surface is given by some authorities as the average in a boy of seven years. From the writer's experience he thinks that this is not enough.

But, be it shallow or deep, the staff must be found. When the operator feels it, he presses the pulp and nail of the left index finger against the groove for a guide and opens the urethra with the point of his knife. He knows that he has done so by the contact of the knife with the metal of the staff, and he should further test by moving the knife from side to side, so as to be sure that he is in the groove.

He now lateralizes his knife, the cutting edge directed downward and outward, and carries it along the groove of the staff into the bladder. In this movement he cuts through the membranous urethra, the triangular ligament, and the neck of the bladder, and doubtless in a child he has divided the whole of the small prostate and has incised the peritoneum. A slight flow of urine will indicate that the bladder has been entered.

The staff is still in place, and the wound is so small that there is not often a gush of water at this time. This is in children the most critical part of the operation, for now the surgeon, guided by the staff, must pass his left index finger into the bladder; and on no account should the staff be removed until this is done. The pliable tissues of a child may easily be pushed before the finger. But there is one unmistakable sensation, to be learned only by experience, when the finger enters the bladder. It is exactly like that of passing it through a button-hole. In a very young child the pulp of the finger only may pass. In larger children it will pass in by the side of the staff and often feel the stone.

The holder is now directed to withdraw the staff, and then comes a gush of urine, and the stone is generally felt, although, if small, it may have been forced out along with the water. But, being felt, the operator takes up the forceps with his right hand, and, guided by the finger of the left, he passes them into the bladder and seizes the stone, a movement which is sometimes aided by another gush of water, after withdrawing the finger, driving the stone between the blades of the forceps.

If the stone is small, it may be removed at once; if large, it must be extracted deliberately, for the possibility of the successful removal of large stones by the perineal route is founded upon the dilatibility of the parts through which they and the instruments holding them must pass. To pull rashly at this stage may tear, and will stimulate contraction, but gradual traction and dilatation generally accomplish the object in a short time.

When the operator puts his finger into the bladder after extracting the stone, which he must always do in order to find out whether there are more stones, or whether the bladder is free from débris, he is always surprised at the small opening that has been made.

Any immediate hemorrhage must now be checked. The bladder should be washed out through the wound. The patient then is to be dried and prepared for bed. He should lie on a rather hard mattress, well protected by rubber cloth under the sheet. No particular dressing to the wound is required, but a thick layer of absorbent cotton should be placed beneath the buttocks, to receive the urine which at first flows altogether from the wound. This should be frequently changed by the nurse.

It is useless to try to force a child to lie in a fixed position. Let him seek his own comfort as much as he can. If he is too restless, bandage his legs lightly together from below the knees and up the thighs. There is, however, one imperative rule,—keep him in bed until the wound is healed. Great trouble may come from not doing this, especially incontinence of urine. Children do strange things sometimes without harm, but the risk from disobedience or carelessness in these cases is serious.

The time for recovery varies from two to six weeks. Children, especially those from the poorer classes, from which most of them come, should take nourishing but easily-digested food, as milk, eggs, etc., from the beginning.

This is the history of a smooth case of lateral lithotomy. Before considering the untoward events that may occur, we will give a short account of the median operation, as some of the unfortunate incidents are also common to it.

**Median Lithotomy.**—By the median operation access to the bladder is obtained through a central incision along the raphé of the perineum in front of the anus. A staff with a central groove is passed into the bladder and held in the same way as in lateral lithotomy.

There are now two ways of proceeding,—one which is often called brilliant, the other safer for most operators. In the first the index finger of the left hand is passed into the rectum as a guide against wounding it. The knife is then entered on the line of the raphé at a safe distance in front of the anus, with its cutting edge upward. It is pushed right on until it is felt in the groove of the staff. The surgeon must now be certain that he divides the urethra, of which he judges by the contact of the two metallic surfaces, just as in lateral lithotomy. He then withdraws the knife, and in doing so he enlarges the perineal incision from within outward and upward, according to the extent of the perineum before him, or according to the room which he thinks he may require. The staff is still held in place, and a long director or blunt probe is passed along its groove into the bladder. The staff is now withdrawn, and the surgeon follows the director with his finger. He feels the stone and removes it with the forceps.

The safer method, as we have called it, is to cut deliberately from with-

out inward and from above downward until the staff is reached, the other steps of the operation being strictly observed.

The claims made in favor of the median operation are that it avoids wounding the prostate and the important blood-vessels of the perineum, and that it is simpler than lateral lithotomy. Against it, it is said that it gives less room, the structures are not so dilatable and are more apt to be torn, and there is a question as to its simplicity. It is therefore appropriate in children for the removal of small calculi and foreign bodies, for if these have entered by way of the urethra they may be also in most cases taken from it. Special considerations for its performance pertain to the adult.

In the operations described it will be noticed that the operator uses but one knife. This is a matter of choice, for many prefer after reaching the staff to change the first knife for a probe-pointed one. The old-fashioned cutting gorget is practically discarded. There is force in the objection to a probe-pointed knife, especially in children, that the parts may be easily pushed before it, so that they are not cut through at all, whereas the sharp knife cleanly and surely divides what is necessary. Of course the latter requires to be kept with greater care in the groove of the staff.

**Complications.**—Keyes, in his article in Ashhurst's "Encyclopædia," already quoted, enumerates seventeen possible complications during perineal lithotomy, fifteen after it, and four possible after-effects. These are surely enough to show that the path to recovery is not always smooth. Some of these are peculiar to the adult. Those which are common to both adult and child are the following.

*Failure to Enter the Bladder.*—This may occur from the staff, through some movement of the staff-holder, having slipped from its place, or from the incision being too small to admit the finger, or from the knife, particularly a blunt one, pushing the delicate membranous urethra before it, and possibly separating it from its connections. If the faulty conditions should not be detected and the operation is proceeded with, the operator will find himself working in the ischio-rectal space. If detected, the first fault is to be remedied by replacing the staff. If the incision is too small and the operator does not get with his finger the unmistakable sensation of having entered the bladder, he should not, in the child at least, persist in his efforts to do so, and thus risk pushing the bladder before him, but he may carefully enlarge the incision, or, what probably is better, he may introduce a director through the wound and by the side of the staff into the bladder. The staff may then be withdrawn, and there should be no difficulty in passing the finger along the director, as in median lithotomy.

*Wounding the Rectum.*—It is said by some that this is a common event in children, and that in them the wound mostly heals along with the legitimate incisions. There may be some cases where the accident is unavoidable, but the writer thinks that with care it should not occur. A small wound requires no treatment at first. If obstinate, its edges may require cauter-

izing before it will close. Larger wounds may be stitched, but to have to do this is rare.

*Hemorrhage.*—We will speak of this both as a complication of the operation and also as secondary. There is not often in children much trouble on this score. The bleeding points are more readily got at than in an adult. The ordinary instruments before mentioned, together with hot water or hot alum-water, will mostly be all-sufficient. If not, the shirted canula or the small rubber air-bag may be used. The writer never saw a case in a child where they were required. There is sometimes troublesome after-bleeding. The bladder fills, and it is hard to tell where the blood comes from. It may be from the kidneys. If from the deep parts of the wound, the pressure of clot may be advantageous. Washing out should be done with hot alum-water, and in these cases, if the source of bleeding is made out to be from venous plexuses about the wound, plugging may be resorted to.

Dr. Brinton recently had a case in a boy who had several such hemorrhages, exactly from where was not found out, but, notwithstanding, the patient made a good recovery.

The child sometimes dies of exhaustion without any loss of blood, and in spite of all efforts, by appropriate nourishment and other treatment, to counteract it.

*Failure to Find the Stone.*—We have seen this happen in children from causes already mentioned. A small stone may come with the first gush of water and be unperceived. Of course it cannot be found in the ischio-rectal space should the searcher be working there. In children we can hardly claim that the stone is encysted, but it may be held by muscular contraction or by a band of lymph. The writer was witness of a case in a child in whose bladder after a long search the stone was found attached above the pubis in some mysterious way. The child recovered.

Sometimes there is no stone at all, and never has been one. How this may occur, even with men of experience, has already been explained in the section on sounding.

*Retention of urine* from swelling or clot happens in children. When from swelling immediately after the operation, the child soon learns to pass water by the urethra. As the swelling subsides, the urine again flows through the wound. This is an important thing for ignorant attendants to be instructed about, for they naturally think that the child is much worse when the flow through the wound comes the second time. When retention is owing to clot, it may easily be removed, or a female catheter may be made to penetrate it. Suppression of urine rarely, if ever, occurs in children. If it does, it is due to some general cause and is to be treated accordingly.

*Peritonitis* is agreed to be the most frequent cause of death among the few fatal cases of operation for stone in children. The proximity of the peritoneum to the wound and its almost necessary involvement in the lateral

operation may explain this. But the mortality of the median operation is equally great. In these days of vast experience as to the safety of peritoneal wounds under proper precautions, the explanation is not satisfactory. It would be interesting to know whether in the fatal cases of peritonitis following lithotomy in children the patients have not been subjected to undue handling, from causes or mishaps heretofore mentioned. A clean cut into the peritoneum, which is almost necessarily made in the lateral operation in children, could not fairly be charged with the fatal result without something more to induce it.

Peritonitis is to be treated as in other cases of the malady. Salines should be given, and opium, if used at all, very sparingly. Advantage may be taken of the wound to keep up free drainage and washings and to make local applications.

Among the *after-effects* of lithotomy in young subjects there may be incontinence of urine. This generally ceases in time. Probably it comes more from too early getting about after the operation than from any other cause, and is therefore a matter of prevention rather than of cure. When it is obstinate, cauterization of the neck of the bladder has in some cases proved effective.

*Sterility* is said to be one of the permanent consequences of the perineal operations, and a few post-mortem examinations showing obliteration of the seminal ducts and vas deferens would seem to sustain the view.

Anatomical considerations should make division of the ducts exceedingly rare, and, besides, in the operation most often done (the lateral) but one side is involved. In the cases quoted by writers there is no proof of what the condition was before the operation. Surely nothing could be imagined more likely to bring about obstructive lymph-deposits and inflammatory thickenings than the long-continued irritations of stone in the bladder.

In this connection the writer has a curious experience to relate, which shows how that which is quoted as positive authority may have very little or no foundation.

Of late the enthusiastic advocates of supra-pubic cystotomy have dwelt much on sterility following the perineal operations. Thus, Dennis<sup>1</sup> quotes Halberstadt, of Pottsville: "Halberstadt reports eighteen lateral lithotomies in which the patients, having grown up, married, and only one out of these eighteen cases had issue;" and Dr. Tremaine<sup>2</sup> is reported thus: "He then reviewed the dangers which accompany the cutting operations for stone which reach the bladder through the perineum. One of the most important, and one which is too often entirely disregarded, he said, was that of impotence. As evidence of this he referred to eighteen cases of stone, all in young boys, which had been operated upon by a surgeon in Pottsville,

---

<sup>1</sup> Transactions of the American Surgical Association, 1887, vol. v.

<sup>2</sup> American Medical Association, Newport Meeting, 1889: Medical News, Philadelphia, July 12, 1889, p. 50.



Pennsylvania. The subjects of the operation have all since grown up, have married, and but one of them has become a father. While there were many other ways of explaining sterility, he thought that under the circumstances so large a number of successive cases argued strongly for its being due to the operation." The observation about the eighteen has become famous and is quoted repeatedly.

Dr. T. S. K. Morton was at the Newport meeting and heard the debate, and in telling me of it afterwards (never doubting the statements) he said there was a tone of mutual satisfaction prevailing at having such definite and strong support in favor of the high operation.

But I wrote to Dr. Halberstadt. He answers, July 7, 1889, "Two of my subjects, cut between the ages of seven and ten, grew up, married, their wives had children, *in one case twins*. I have every reason to believe the children were legitimate, as the paternal resemblance was marked."

The eighteen turned up somewhere else in my reading, and I wrote again. This is from the answer of September 29, 1889: "I *did not* follow eighteen who married, but lost sight of them after recovery from operation; I do not know how many of the eighteen married." He then refers to the two cases above mentioned. Dr. Halberstadt is now anxious to find the origin of the statement, for he says, October 30, 1889, "It cannot be possible that any such information ever came from me." While he does not deny that perineal operations may be a cause of sterility, he has had no such experience about the eighteen with which he is credited.

**Stone in Female Children.**—This is rare, the proportion being about one case in the female to twenty cases in the male. Anatomical reasons forbid any operations like the perineal ones done on the boy. Besides pain, prolapse of the rectum and incontinence of urine are the prominent local symptoms. The child also handles the parts, but not to the same extent as the boy does. A straight or slightly-curved sound should be used for diagnosis.

The patient must be etherized, and it is a good plan to have instruments ready to crush or to remove the stone should it be small, for nothing like the formidable preparations for operation are necessary that are required in the boy.

While there are no true perineal operations, the stone is often removed through a perineal route,—that is, by way of the female urethra. Girls are more apt to have foreign bodies, as hair-pins, etc., in the bladder than boys, and the operator should be mindful of this.

The dilatibility of the female urethra even in young children is really astonishing. It is this fact that allows them to get rid of small stones without artificial assistance, and, on the other hand, it is the same fact that may make the surgeon presume too much, so that his operation is apt to be followed by obstinate and sometimes incurable incontinence of urine.

The surgeon really begins his perineal operation in the female at the corresponding point which he is anxiously striving to reach with his staff

and knife in the male. If there is any structural resemblance between the male and female urethras at these points, there is no difficulty in believing in Dr. Otis's utmost dilating possibility.

Moderate dilatation alone serves for the removal of small stones, and the forceps may be used both as a dilator and as a remover. But sometimes greater dilatation is required, and this may be done by either the rapid or the slow process.

The slow method consists in introducing a screw-forceps and opening it by increasing widths every day, and also catgut bougies may be worn in the urethra in the interim, or they may be exclusively used. That this gradual and careful dilatation does not tear is doubtless the case, but, when the final work comes of getting out the stone, it is questionable whether any advantage as to after-incontinence is gained over the rapid method, and so the latter is most in vogue.

In rapid dilatation the screw-dilator is used more quickly, or bougies of increasing size are inserted one after the other. The finger as soon as it can be introduced is best of all, for it not only dilates, but the bladder at the same time is examined, the stone felt, and a conclusion arrived at as to whether further pursuit of this method of removal is to be continued. The dilatation having been accomplished, the stone is seized by a forceps and extracted.

Cutting operations in order to dilate more easily and to gain more room consist in incising the urethra in various directions. The names of high authorities, and their peculiar methods, are given in works on surgery.

Some cut upward, some downward, and some laterally; some only a fraction of an inch, and some an inch.

The writer thinks that, while in some cases a small incision might do no harm, still in these days of litholapaxy there is no necessity of making them, as great harm might follow. Permanent incontinence in the female is much more to be dreaded than impotence in the male. When discussing lithofritry and litholapaxy, operations on female children will again be noticed.

**The High Operation. Supra-Pubic Cystotomy.**—The method of extracting calculi through an incision above the pubis is ancient, and has a history most remarkable as to origin, progress, decadence, and revival.

As an illustration of its once complete disappearance from surgical favor, Carpue quotes an "eminent practitioner" as saying, when he was discussing some point in practice, "Gentlemen, it is as absurd to talk of this as of the high operation for stone." Of late the operation has been revived, and, as a contrast to the above condemnation of it, we will quote one of the enthusiasts in its favor in this decade: "Within ten years the supra-pubic operation will be the operation adopted for all cases of stone that are not treated by Bigelow's operation."

We can merely allude to the historical phase of the subject here. Much has been written, in many languages, about it. The writings of Carpue,

C. W. Dulles, Sir Henry Thompson, Packard, Dennis, and many others are of great value and interest.

This article is concerned in the applicability of the operation to cases of stone in children. A large number of the supra-pubic lithotomies that have been performed both in former and in recent times have been upon young persons. What is peculiar in the anatomy of the bladder and its relations to the pelvis and peritoneum has already been described (page 602). A knowledge of the anatomy of the abdominal walls common to so many operations is the other topographical requisite.

The high operation has undergone many modifications. As late as 1880 the *sonde à dard* was considered an essential instrument, or it was substituted by a solid catheter or an ordinary sound. These instruments are passed through the urethra; the blunt ones are pressed against the bladder-wall from the inside, and, being felt by the surgeon through the abdominal incision, they become his guides for entering the bladder. The *sonde à dard*, an old contrivance, contains a sharp steel grooved stylet which is made to pierce the bladder-wall and appears in the external wound, thus making a most excellent guide.

Now these operations are mostly discarded, and the method in vogue is based upon the power of a distended rectum to push the bladder upward and forward against the abdominal walls. See Fig. 3 in illustration of this. It is reduced from the figure in Sir Henry Thompson's small volume on the supra-pubic operation. It is taken from one of the frozen sections of Garson. One would be apt to think it is an exaggeration; but I saw in the summer of 1889 one of these preparations in Edinburgh, and I can confirm the truthfulness of the cut in every particular.

The operation is simple. First a colpeurynter or india-rubber bag is greased and introduced into the rectum, and through a tube with a stopcock attached it is injected with water or, preferably, a boracic-acid solution. If there is no stopcock, the rubber tubing or mouth of the bag may be tied. Then, through a flexible catheter introduced into the bladder, this viscus is injected with the same solution and the base of the penis is tied with a piece of rubber tubing.

Both injections should be made slowly, and a nice point is to judge correctly as to quantity. An average for an adult is from twelve to fourteen ounces for the rectum, and from eight to ten ounces for the bladder. It is

FIG. 3.

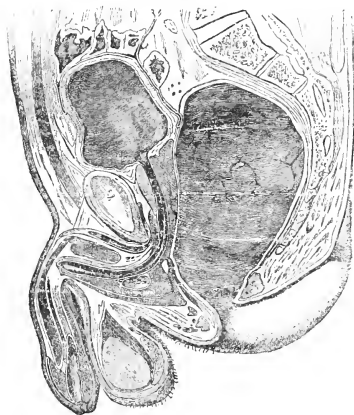

to be remembered that a young bladder is naturally higher than that of the adult and much more lightly attached below. The quantities of fluid required for children, therefore, are not nearly so great, but must be determined according to age. From less than one-half to two-thirds of the amount for adults may be used; and the surgeon's tact must come in, for when he feels the bladder rise and present a good projection in front it is time to stop. Nearly all the serious mishaps in this operation have occurred from ill-judged injections in both rectum and bladder; for the patient, be it remembered, is under anæsthesia and can through his sensations be no guide.

The operator stands on the right of the patient. He makes a longitudinal incision immediately above the pubes and in the median line. The skin, superficial fascia, and fat are divided, and the linea alba is brought into view; this may be slit up on a director, and the muscular fibres separated by the handle of the knife or by the fingers. Sir Henry Thompson uses an ivory separator, which is preferable if at hand.

The transversalis fascia is now reached, for there is no posterior tendinous layer of the sheath of the rectus in this position. This fascia may also be divided with the separator. In children it is very delicate. Beneath it some yellow fat will be found; under this is the bladder, which, if injected rightly, should be felt without difficulty. In this approach it is of great advantage not to use the knife, as abundant veins are in the connective tissue about the symphysis.

After recognizing the vesical wall and clearing it for a small space, a tenaculum is introduced into the bladder. If it has entered, a few drops of water will flow out. Retaining the tenaculum in place with the left hand, the operator with his right makes an incision through the bladder-walls large enough to admit his index finger. He now judges of the size of the stone, and, if necessary, he enlarges the incision. He should not cut too freely downward towards the neck of the bladder, as not only troublesome hemorrhage but also dangerous infiltration might ensue. He may cut upward more freely, keeping the peritoneum in mind. But in either case dilatation with the fingers is preferable, and the knife should only be used as a necessity.

The bladder at this stage must be kept well up to the abdominal wall, for the water flowing out will cause it to fall away if not supported. It is good practice in some cases to introduce a loop on each side of the incision and let an assistant support the parts by them. Size permitting, the best and safest forceps for withdrawing the stone is made by the two index fingers of the operator. He locks his other fingers together, and introduces the indexes into the bladder, one on each side of the stone. He then by pressure seizes the stone and withdraws it. This plan failing, forceps of different patterns may be used. Scoops also are sometimes required.

The bladder is now examined for other stones or débris, from which it is freed. If necessary, the patient may be placed on his side, and the bladder washed out through a piece of tubing.

The essential operation is now completed, for the question of suturing the bladder is still an open one. If done at all, it must be done thoroughly, and even after this the sutures are apt to give way.

In many cases it is a process of great difficulty, and the necessary or injudicious extra handling may do great harm, not only in itself, but also by prolonging the operation. Besides, experience has taught that the cases do equally well, if not better, without it. The old operators never did it. Sir Henry Thompson did not do it in eight cases which he reports. One of these only, an old man, died. Dennis condemns the practice in stone operations, but thinks it best to follow it for other causes, as in rupture. He quotes twenty-five stone cases, collected by Schmitz, in which suturing was done. Six of these died, and in only four did primary union occur.

The practice, then, of not suturing being followed, the patient lies at first on his back and then shifts from side to side. The water may be drawn by the urethra through a soft catheter three or four times daily, and what does not come this way drains from a tube in the wound for the first few days and then without it. The tendency to contract and close is great, and shortly all the water passes by the natural outlet. Young children, of course, cannot be made to understand the importance of co-operation as to position in the after-treatment, but much may be done to aid them by a judicious nurse.

The dangers of the high operation are said to be—1st, from opening the peritoneum; 2d, from extravasation of urine. Careful operating should render the first almost impossible, and, even if it were to happen, with the present methods of treatment the danger is not great.

The second incident is no more dangerous than extravasations after the perineal operations, and may be as readily combated. It mostly comes from faults in the operation, such as too much working low down and so disturbing the vesico-pubic space.

I. Greig Smith, M.A., F.R.S.E., in his work on Abdominal Surgery, 1889, says, in the article on supra-pubic cystotomy, "Taking the case of young children first, we often hear it said that for removal of stone in the bladder we do not want a better operation than lateral lithotomy. Recent work in crushing would seem to show that here we have already got an operation at least as good as, probably better than, lateral lithotomy, while as regards remote results there can be no comparison." He then mentions some of the almost incurable evils, as perineal fistula, traumatic stricture, etc., that he knows to have followed perineal operations. He mentions sterility, and quotes Halberstadt's immortal eighteen, and then continues, "Stricture, fistula, sexual incompetence,—separately or combined,—must be admitted to be rare sequences of perineal lithotomy. But that they are possible sequences cannot be denied. Now, if the supra-pubic operation can show immediate results as good as the perineal, and a complete absence of remote drawbacks, then the supra-pubic operation should be selected. Even if the percentage against the perineal were as small as one, this one case for fixing

a rule in sound surgery should be decisive. In children, therefore, I should say that, where the crushing operation is negatived, the supra-pubic should be adopted. A further argument in favor of its adoption in children is the favorable position of the bladder and the usual healthy condition of the involved tissues."

In reply to the above the writer would ask, Suppose against the supra-pubic operation the mortality percentage was two, which operation should be selected? It would seem that there is an assumption of nothing against the supra-pubic operation, which does not agree with the record.

Whatever may be said as to deliberately choosing the high operation for stone in preference to all other cutting operations, most surgeons, I think, are now agreed that it is *the* operation for stones which are much above the average size.

Sir Henry Thompson as late as 1886 gives, as reasons in support of this view, that there are no important structures to be wounded in the incisions, greater space for removal is obtained, there is no danger from hemorrhage, the operation is easy, the urine leaves the bladder more directly than by the lateral method, and antiseptic dressings may be effectually employed. The dangers from over-injection of both rectum and bladder have already been spoken of. This over-injection, by producing rupture, is a serious and mostly fatal event, and should be particularly guarded against.

In female children, as the bladder is already high, it alone may require injection. Where the generative organs are not developed to any extent, a rectal bag might be used with advantage. As before stated, this method of removing a large stone in females is preferable to the risk of having permanent incontinence of urine by incising the urethra.

**NON-CUTTING OPERATIONS.—Lithotrity.**—Old-fashioned lithotrity is no operation for children. A small soft stone, particularly in a girl, might be crushed with a lithotrite or forceps and be allowed to come away with the urine or be washed out, but experience is against any general application of the method to patients under the age of puberty. In fact, it may be said now to be almost abandoned even in cases of adults, and to be but an essential part of the operation to which we shall now give attention, that of

**Litholapaxy**, in which lithotrity, or the crushing, is the first step, and litholapaxy, or the immediate evacuation of the fragments under prolonged anaesthesia, is the second and final one.

The general fitness of the operation for children is still a matter of doubt, but the verdict of many trials is decidedly in its favor in well-selected cases. There are those who reject it, and those who advocate it, with almost the same intensity of opinion as in the examples given in the section on the high operation.

The names of Bigelow of Boston, Otis of New York, and Sir Henry Thompson are inseparably associated with this method of removing calculi from the urinary bladder. It was Otis's demonstrations of the dilatibility of the male urethra without injury to its structure or functions that made

litholapaxy possible, for by them it was proved that evacuating catheters of large calibre could be safely passed into the bladder.

The historical details of the rise of litholapaxy will not be treated of here. Keyes, in Ashhurst's "Encyclopædia," and others have written of them in full. As in most other matters of the kind, there is a history of slow growth and unsatisfactory efforts to accomplish a desirable end, until at last the one entitled to be called inventor appears, and in this case that honor is due to Bigelow.

Sir Henry Thompson accepted the operation and has done much to perfect its methods; and Otis, as we shall see, has worked in the same line and produced an original apparatus, besides having the glory of discovering the most essential fact on which the operation is founded.

We will in this article confine ourselves to an account of the use of the Bigelow and the Otis apparatus, as either of them may be readily used in cases of children. The same bulb or washing-bottle may be used in any case, but particular attention must be given to the size of the evacuating catheter and the lithotrite, according to the age.

Bigelow's latest evacuator (Fig. 4) consists of an elastic rubber bulb, to the lower end of which is attached a glass receiver. Opposite this at the upper end a metal stopcock is inserted. By this the bottle is filled. To one side of and above the glass receiver there is another metal stopcock fixed in the bulb, and to the short tube projecting from this stopcock the evacuating catheter fits when the instrument is in use. There also projects from this opening into the bulb a finely-fenestrated tube open at the end. This last is to prevent fragments of stone returning to the bladder, and to catch mucus, coagula, etc., for it will be noticed that the obliquity of the fixtures here directs the current away from the receiver, so that fragments of stone by gravity fall directly into it after leaving the tube. There are no valves, and no tubing. The piece of tubing in many pictures is not essential, but is only a convenience for filling the bulb by suction, for which also a funnel is used, but the bulb may be easily filled by immersing the whole of it after opening the stopcocks. An essential point, especially for children, is the workmanship of the eye of the catheter. There should be nothing cutting or projecting about its edges, but these should be blunt and turned a little inward. A stylet accompanies it, to be used if it gets choked. Great harm could come to the delicate structures of a child from any defect in the instruments which are to be introduced into the bladder.

Much is said about the preparation of the patient for the operation of litholapaxy. This may be advisable in some adult cases, but the writer would suggest whether in children at least it is not time lost to spend days in giving medicines, washing out the bladder, etc. Cases of all kinds in surgery, and particularly chronic ones, among which stone cases rank, improve so rapidly when the cause of their trouble is removed and so stubbornly resist any treatment when it is not removed, that one is forced to believe that the sooner positive action is taken the better it is for all

concerned. The great incentive to recuperation is the removal of the irritating cause. If the child is not sick in any other way, and if his bowels are clear, he is ready for the operation.

FIG. 4.

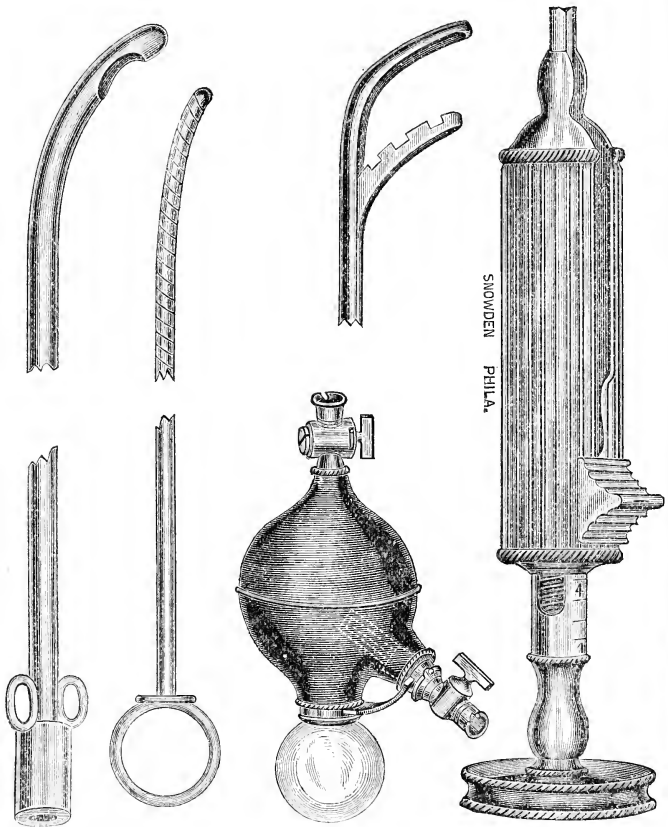

The assistants required are the etherizer, one to attend to the bottle and to refill it during the different crushings, another for general purposes, and the nurse.

The patient is to be laid on a narrow table which has been covered with a blanket, a rubber cloth, and a sheet; his hips should be elevated with a pillow. The evacuating catheter should be first passed, to empty the bladder of urine, so that a clear comprehension may be had of the amount of fluid which is to be thrown into it.

In the mean time the bottle or bulb has been nearly filled, say, with a



borax or boracic-acid solution (than which there is no better). To clear the catheter from air, withdraw it into the urethra, then with the bulb compressed attach it to the catheter and remove the pressure. The air will pass through the water and remain at the top of the bulb.

The catheter is passed back into the bladder and two or three ounces of the solution are thrown in, and the whole apparatus is withdrawn, for now all is ready for the lithotrite.

This the operator uses to his satisfaction by crushing the stone as thoroughly as he can. In most cases suitable for the operation in a child, one introduction of the lithotrite and a thorough use of it should be sufficient. To go through this step of the operation more than twice at one sitting is scarcely advisable, but, as in adults, the condition of the patient must be the guide.

The crushing being done to the satisfaction of the operator, the lithotrite is withdrawn. The evacuating catheter is introduced, and some of the crushed stone will flow out through it. It is then fixed to the bulb, which is filled with the solution, after withdrawing any air as before, and the bulb is worked by alternate pressure and relaxation of the hand of the operator. Thus a current is set up into the bladder by pressure and out of it into the bulb by relaxation. This latter current brings with it the fragments of stone, which fall into the receiver entirely out of the way of the current, so that they are not stirred up again, sometimes to return to the bladder, as was the case in some of the former contrivances.

A considerable amount of blood and mucus often comes with the fragments, but unless excessive this should not give alarm. At times the view of the fragments in the receiver is obscured. Glycerin in the bottom of it is recommended to prevent this. When all the fragments that can be obtained have come away, the catheter is withdrawn, and the crushing and washing are repeated, at the judgment of the operator.

From the above it will be seen that at no time, if properly managed, is there much, if any, increase in the quantity of fluid in the bladder, so that danger from extra pressure is not great. The bladder, the catheter, the bulb, and the receiver are really parts of a continuous chamber, and it is the current set up in it that does the cleansing work. After carefully searching and listening for final fragments and finding none, the operation is completed, and the patient must be put to bed.

*Otis Evacuator.*—We will now give a description of the Otis perfected evacuator in the inventor's own words :

“The Otis ‘perfected evacuator’ consists of a strong glass globe, two inches in diameter (the reservoir), into one side of which a hard-rubber tube (3) is inserted, curving down to its lowest part. The superior end of this tube connects directly with the proximal end of the evacuating catheter. To the floor of the reservoir a strong glass bottle (the receiver) is connected by screw-threads moulded on the necks of the receiver and the reservoir respectively, and fitting a hard-rubber collar, into which the corresponding

screw-thread is cut. On the side of the reservoir opposite the tube connecting with the evacuating catheter is another tube, of smaller calibre, curving upward to near the top of the globe. By this means the current

FIG. 5.

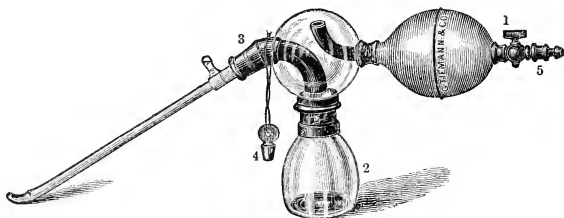

The Otis perfected evacuator.

is so directed that it flows between the two tubes, leaving the receiver below a perfectly dead point; fragments dropping into it by their own weight remain quietly there without the intervention of traps, strainers, or valves, and, this part of the instrument being entirely transparent, it is easy to observe that the fragments do not return to the bladder. Connecting with this tube of entrance to the reservoir is a strong rubber bulb, which in some form constitutes the power in all the modern evacuators. A small stopcock has been inserted in the end of this bulb, for convenience in introducing fluid into the bladder during operation. This is the only stopcock connected with the instrument, as the atmospheric pressure is found to be sufficient to retain the water in all positions necessary during operation. In case, however, it becomes desirable to lay the instrument down on its side, a hard-rubber plug (4) has been added which fits the tube of exit. The joints of the instrument have all been constructed in such a manner that they are brought tightly against the glass by means of screw-threads, so that freedom from leakage is assured, there is no cementing substance to give out, and the surgeon himself can take the instrument entirely to pieces, either for cleansing or to replace an injured part. To fill the instrument it is only necessary to submerge the end of the tube of exit and by repeated pressures of the bulb the air will be replaced by fluid. Should any air still remain, it is of no particular import, but may be entirely removed by submerging and inverting the instrument, when the air can then be let out under water.

“After a crushing, the lithotrite having been removed, a suitable tube is introduced into the bladder, and whatever fluid remains is allowed to flow out, carrying with it a certain amount of débris. The evacuator, which has been filled with fluid (preferably a saturated solution of boric acid), is then attached to the catheter, an ordinary Davidson’s syringe connected with the stopcock at the end of the bulb, and any desired quantity of fluid easily and exactly introduced into the bladder. Pressure of the bulb with

a quick relaxation will be followed by a shower of débris into the receiver, and this is to be repeated as long as any fragments appear falling into the receiver, when another crushing should be made. Should any bleeding be present, it will, by rendering the fluid opaque, make it difficult to tell whether fragments are falling or not: this may be avoided by filling the receiver with glycerin, which, owing to its specific gravity, will remain clear and unmixed, the fragments falling readily through it. This experiment also offers conclusive proof that the receiver is entirely out of the current.

“This instrument, on account of its lightness and small size, is particularly adapted for operations on children. It is not at all necessary to use a smaller instrument for them, as is the case with lithotrites and tubes, but with evacuators it is the current set up which removes the débris, so that, contrary to a very common supposition, a large volume of water is not forced into the bladder, but only one or at most two ounces. It must be remembered that no force is necessary, and especially with the delicate bladders of children should the greatest gentleness be used.

“In regard to the size of instruments to be used in the urethræ of children, this may be determined with sufficient exactness in all cases by measurement of the flaccid penis. The proportionate relation between the circumference of the urethra and that of the penis I have already demonstrated.<sup>1</sup> According to this, the average adult penis, measuring three and a quarter inches in circumference, is found to indicate a urethral calibre of thirty-two millimetres' circumference, this increasing or diminishing by about two millimetres of circumference for every quarter-inch added to or subtracted from the circumference of the penis as above cited. This proportionate relation holds good equally in children. Thus, with a circumference of penis of one and a half inches, as in a child from two to three years of age, the size of the urethra would not be less than sixteen millimetres' circumference, one and three-fourths inches eighteen millimetres, two inches twenty millimetres, and so on. I have never known this estimate to prove excessive; on the contrary, it usually falls short of the true normal calibre by one or two millimetres. It must be borne in mind, however, that this has no reference to the size of the urethral orifice, which is subject to very great variations, having no fixed relation to the calibre of the urethra behind it. If not of normal size,—*i.e.*, of the calibre behind it,—and not readily dilated up to that size, the orifice should be carefully divided, always inferiorly, to the required dimensions. There is a considerable advantage in attending to this not unimportant detail, and allowing the parts to heal, before the operation of litholapaxy is performed.”

In connection with the above, the fact should not be overlooked that

---

<sup>1</sup> See Otis on Stricture of the Urethra, preface to second edition, p. vi., also p. 242; Diseases of the Male Urethra, pp. 6 and 40 *et seq.*; Genito-Urinary Diseases and Syphilis, Students' Edition, p. 441 *et seq.*, Putnam's Sons, New York.

localized contractions are sometimes met with in the urethrae of children. They are probably never congenital, but the result of an antecedent lithiasis. The failure to pass an instrument of the size indicated by the proportionate relation existing between the size of the penis and that of the urethra calls for an examination with the bulbous sound, which will readily indicate the extent and locality of the contractions. Such strictures, as in the case of contracted meatus, should be divided previous to the operation of litholapaxy.

Very few litholapaxies on young children have been done in this country. Dr. P. Allen reports four successful cases, but the subjects were all in their teens.

Abroad, however, great success has attended the operation, as will be seen in the statistics below. A child three and a half years old will take a No. 8 English catheter with safety. Owing to the dilatibility of the young female urethra, well-conducted litholapaxy is admirably adapted to cases in that sex.

STATISTICS.—A goodly portion of this volume might be occupied with statistical tables of operations for calculi, with their results, both in the old times and in the new. What interests us here are the results of the operations upon children. From early times all the cutting operations have been practised upon them, that of lateral lithotomy much oftener than any of the others.

Deductions from figures have only a general application, as so many circumstances enter into the individual case that we are not justified in determining on a certain operation merely because the tables give the best record for that operation. We shall therefore give only the latest figures from operations upon children, advising any one more deeply interested to consult the innumerable tables in various surgical works.

The following letter<sup>1</sup> very well represents the success generally obtained in the perineal operations:

**“Statistics of Perineal Lateral and Median Lithotomy.**—A few months ago my friend Mr. Reginald Harrison wrote to me with a request that I should supply Prof. S. W. Gross, of Philadelphia, with a tabulated statement of all the cases of lateral and median lithotomy performed on infants and boys up to fifteen years of age in the Wolverhampton and Staffordshire General Hospital. Mr. Gough, house surgeon, at some trouble, grouped together all these particular cases of operation from the hospital books, and the list was forwarded to Prof. Gross; but, his lamented death soon afterwards having doubtless prevented its publication, I feel that, as the record is one of practical interest and value, I ought no longer to refrain from making it known.<sup>2</sup>

<sup>1</sup> T. Vincent Jackson, F.R.C.S. Eng., London Lancet, August 24, 1889, p. 367.

<sup>2</sup> When the plan for this work was under consideration, Prof. Samuel W. Gross, of Philadelphia, engaged to write the article on “Stone.” He manifested great interest in the

From 1864 to 1888 inclusive, of lateral lithotomy—there were performed—

On cases from	1 to 5 years inclusive,	70 operations,	with 2 deaths.
“ “ “	6 to 10 years “	47 “	“ 2 “
“ “ “	11 to 15 years “	13 “	“ 1 “

Median operations were performed—

On one case of	15 years,	1 “	“ 0 “
“ “ “	11 years,	1 “	“ 0 “
		132 “	“ 5 “

Two of the five, two and three years old, died of shock, one, nine years old, of peritonitis, and one, fourteen years old, of secondary hemorrhage.

Between 1 and 5 years there was one death in 35 cases.

“ 6 “ 10 “	“ “ “	23½ “
“ 11 “ 15 “	“ “ “	13 “

the mortality being between three and four per cent.”

After relating the method of making up the table and showing how wholly trustworthy it is, Mr. Jackson concludes his remarks thus: “I do not think it desirable to lengthen this short paper by copying the lithotomy tables and the conclusions which are to be drawn from them which are to be found in various published papers, monographs, text-books, and surgical treatises, as I wish these observations to be considered a contribution to the very important subject of perineal lithotomy in male children and boys, especially as at present the employment of other operative methods of dealing with this particular surgical disease is being strongly recommended to be adopted, as it were, to the effacement of that time-honored operation for the removal of stone from the male bladder,—viz., the great English surgeon’s improvement of Frère Jacques’ method.”

**The High Operation.**—Sir William MacCormac, F.R.C.S., gives the following statistics.<sup>1</sup> In fifty-five recent foreign cases in children the mortality was twenty-three and three-fifths per cent.; in thirty-three recent British cases in children there were no deaths; and in twenty-five cases in children from the table in Vander Veer’s paper in the “Transactions of the American Surgical Association” for 1887 (vol. v.) the mortality was eight per cent.: *i.e.*, in one hundred and thirteen cases in children under fifteen years of age the mortality was ten and one-half per cent.

When we consider that for this operation the cases are as yet selected, mostly because they are unfitted for other methods, the record is remarkable, that of the British cases particularly so.

**Litholapaxy.**—Keyes, in an article in the “Annual of the Universal Medical Sciences,” vol. iii., 1889, gives the following figures. In Surgeon-Major P. J. Freyer’s operations in the Bengal medical service sixteen

---

subject, and proposed to write an article which should give the results of his own experience and include statistics derived from his large correspondence. After his death Mrs. Gross placed at my disposal the matter he had collected; but it was found impossible to make any use of it. Dr. William Hunt thereupon kindly acceded to the request to prepare the article.—EDITOR.

<sup>1</sup> British Medical Journal, March 19, 1887.

litholapaxies on children were performed, without a death. The youngest child was three and a half years old.

Dr. P. Allen's four cases, all successful, aged respectively thirteen, thirteen and a half, fifteen, and nineteen, have already been noticed. Dr. Keyes says these are apparently the first of the kind in this country.

H. H. Clutton operated successfully on a male infant of three years in St. Thomas's Hospital, London. He used a No. 5 English lithotrite and a No. 9 English canula.

E. Hurry Fenwick, of London, records a successful case in a male child aged nine. He collected and tabulated the results in one hundred and six cases of the operation on children, thus :

Between 1 and 2 years,	6 cases,	no deaths.
“ 2½ and 3 “	10 “	“
“ 3½ and 4 “	13 “	1 death.
At 5 “	16 “	no deaths.
Between 6 and 9 “	34 “	“
“ 10 and 15 “	27 “	“
106 “		Mortality, 0.9 per cent.

Surgeon-Major D. F. Keegan, of Indore, records, with table, one hundred and fourteen litholapaxies in young boys, done at the Indian Hospital by himself, Surgeon-Major Caldecott, and Mr. Gunputsingh. There were four deaths.

The showing is remarkable, even more so than that of the high operation, and certainly is encouraging enough for the advocates of the more general adoption of litholapaxy in children.

In addition to the above are to be cited the latest returns of Surgeon-Major P. J. Freyer.<sup>1</sup> Since the sixteen cases were operated upon, sixty-four male children have come under his care. Litholapaxy was performed in thirty-three of these with complete success. It was tried in all the cases, but in twenty-nine he found it necessary to resort to lithotomy. The difficulty, he says, is in procuring the proper-sized lithotrites. The smallest he possessed up to September, 1888, was a No. 7. He then received a No. 5 from Weiss, and since then he has performed Bigelow's operation in twelve out of thirteen cases. He says he has now performed forty-nine litholapaxies in male children and three in female children, without a death. He naturally thinks that litholapaxy will practically replace lithotomy in children. The average weight of the stones in the children was one hundred and twelve grains.

The skill and enterprise of the surgeons of the East, together with their abundant opportunities, give their experience great value. If instruments of the proper size and strength for children are the important requisite, they will soon be forthcoming.

<sup>1</sup> British Medical Journal, October 12, 1889.

It has often seemed curious to the writer that the recent improvements in stone operations should have originated in places where stone itself is by no means a common disease. Comparatively few cases are operated upon in the northeastern cities of the United States, and most of these come from a distance. Lithotomy upon a New Englander used to be spoken of as quite an event in surgery.

CONCLUSIONS AS TO OPERATIONS.—From the foregoing the writer is of the opinion :

1st. That *lateral lithotomy and median perineal lithotomy* still hold and are likely to hold the first place in the minds of most surgeons of this day for the relief of male children from stone in the bladder.

2d. That the *high operation* is advisable in boys in selected cases of very large stones, or for some other particular reason in the especial case. In girls where even a moderately large stone is too hard for the lithotrite, this operation should be performed.

3d. *Litholapaxy*, admirably adapted for girls, is still on trial for boys. There is not yet enough evidence in its favor to justify one in saying that it will largely replace perineal lithotomy and so take the first place in the list, but, from what has just been quoted of Freyer's experience, it looks very like it indeed.

#### PREVENTION OF STONE IN CHILDREN.

As we have seen, most of the patients are from the poorer classes, and are the subjects of ignorance and unfavorable surroundings. If the cases were recognized in the early formative stage, much might be done by the use of proper diet and diluents to work a cure. It seems to the writer that in this stage the deleterious material might actually be washed from the kidneys. The mother's milk, the most fitting, and a properly-diluted cow's-milk diet, are often wanting. Instead of these, all sorts of artificial and often inappropriate substitutes are given. Not only among the ignorant, but even among those who ought to know better, the last thing that occurs to them is to give a child a drink of water. Expensive mineral waters are not required, for the most noted waters in the treatment of stone seem to have purity as their chief recommendation. Plenty of milk and plenty of water, therefore, should be given to an infant having any tendency to stone. Circumcision will help in cases where the condition of the prepuce interferes with free outlet. Beyond attention to clothing and to other general hygienic requirements, the writer has nothing further to suggest.

#### PROSTATIC, URETHRAL, AND PREPUTIAL CALCULI.

*Prostatic stone* is very uncommon in children. A case is related by Ebel which occurred in a boy of three years. As the prostate gland at that age is rudimentary, it was probably a case of local infarction at that point, just as infarctions occur in the kidneys, and the stone, which was not removed until after six years, kept its place and grew, as development of

the gland was going on. Median perineal lithotomy would be the right operation to perform for the extraction of a stone in this position, should ordinary means to dislodge it into the bladder fail. If dislodged, the case would be a proper one for litholapaxy or lithotomy. A very extraordinary case as to size and attachments might require the high operation.

*Urethral calculi* proper sometimes form in the dilated follicles, the fossa navicularis, etc. More often they are due to the escape of small stones from the bladder, and not infrequently fragments after lithotripsy lodge in the passage. Sometimes several stones are found in pouches formed by pressure and dilatation or even existing naturally; but such cases as these are scarcely to be looked for in children.

If after diagnosis, which is made by the sound or a blunt probe, the stone or fragment is not easily moved towards the meatus by gentle manipulation, or is not readily seized by the forceps or a wire loop, it is the best practice to push it back into the bladder and then crush it. If it is very fast in the urethra, this will have to be incised, but, if possible to avoid it, do not incise between the fossa navicularis and the scrotum, as most obstinate fistula may result. Wounds behind the scrotum near the membranous portion heal kindly.

True *preputial calculi* in children or in adults are not common in this country. They are said to be so in China. Small stones may pass from the bladder through the meatus and be held, owing to the preputial opening being too small.

What we often see in children is calcified smegma which collects about the corona and even becomes buried beneath the membrane in cases of phimosis. These cases give rise to symptoms precisely like those of stone. But it does not answer always to rely upon the operation of circumcision for a complete cure, although circumcision is the thing to do. Always sound the bladder after the operation, for just the state of things exists that is spoken of on page 598 to favor the formation of stone in the bladder. I had this experience. A lad was circumcised, as all his symptoms were attributed to his very bad phimosis and hard smegma. He was not sounded before leaving the table. He was only partially relieved. He was brought to me, and on sounding I found there was a large stone in the bladder. I cut him, and he recovered perfectly.

For the preputial conditions mentioned, circumcision and the thorough removal of the offending objects constitute the radical treatment.



# MALFORMATIONS OF THE PENIS, URETHRA, AND BLADDER.

BY DE FOREST WILLARD, M.D.

---

## GENERAL OBSERVATIONS.

FEW cases of deformity more earnestly demand the thorough and conscientious consideration of the surgeon than do those affecting the genito-urinary organs. Even disfigurements of the face, though more apparent to the public, are not more potent in their effect upon the possessor.

The reason is obvious. The mental influences controlling and governing the genital function are of the most subtle and peculiar character, and are consequently more prone to aberration. A degree of deformity which would be simply an annoyance if situated on some other portion of the body becomes when associated with the genitalia so mind-absorbing that the individual is rendered morbidly sensitive and at times becomes almost a sexual monomaniac.

Relief, therefore, from what may be but a blemish becomes at times imperative for its psychical effect.<sup>1</sup> This psychical element will have much to do with the question of

*Time for Operation.*—Unless there is some interference with the necessary functions of life, or some resultant retardation of development, it is not advisable to adopt operative measures of relief until the child has passed the dangers of the first three years of life. By six, however, his companions will begin to annoy him by unkind remarks, and by the age of puberty he may become morbidly unhappy. From three to six, moreover, the child's healing powers are active, and the necessary time required for certain operations is unimportant. This age, therefore, is the one to be selected, as a rule.

At the marriageable age many who have hitherto shrunk from exposure will apply to the surgeon for relief, and in many instances I have found that it has been by the injudicious advice of their physician that they have waited "until they were older."

---

<sup>1</sup> I have seen a man voluntarily debar himself from marriage and almost from society on account of a simple hydrocele; and there are many instances where lives have been rendered lonely and miserable by an exaggerated estimate of disability or defect.

*Marriage.*—When the obstacle to marriage is insurmountable, as in the absence of the uterus or the penis or other essential organ, the physician should give careful instruction to the parents, in order that an early guard be maintained. I have seen most distressing results where it has been imperative to check an alliance after all arrangements had been completed.<sup>1</sup> This question will be still further considered under the head of spurious hermaphroditism.

*Degradation.*—Another morbid direction in which the aberration of a genitally-deformed individual may tend will be that of degradation, provided the malformation be disgusting to himself and to his neighbors, as in exstrophy or extreme hypospadias. Feeling that he is shunned and reviled, the downward steps become easy, or the mind receives a sexual bent and self-pollution or unnatural relations become the habit of life.

This cause alone is sufficient to deter a wise physician from delaying beyond five years of age any form of operation that promises a reasonable hope of improvement. Too often the sad results have been produced by an ignorant or procrastinating physician who has been lacking in the patience or in the skill that is so often required.

The laity are excusable to a certain degree in their neglect of conditions that are not pain-producing, but it is incumbent on the profession to educate the people not only in this class of cases but also in all other deformities of the body, since success in life is dependent in a large degree upon the removal of every hinderance to physical and mental development.

Every orthopædic surgeon is compelled to spend months in the correction of bony deformities in large children and in adults, which at birth were but slight malformations. Frequently these exaggerated conditions are due to the "let-alone" policy of the physician, who should have known that the early weeks of life, while the parts were soft and pliable, were of the most vital importance for corrective purposes.

In genital deformations there is sometimes an excuse for waiting one or two years, but there can be none for delay beyond five, if progressive surgery offers any hope whatsoever for improvement of the condition.

When the absolutely essential organs of child-bearing are absent, or the malformation is so great as to preclude the possibility of the production of children, it is good surgery to unsex the patient, be it either a male or a female, before it reaches the age of ten.

Laparotomists remove the ovaries for far less potential reasons, and, judging both from animals and from the history of the eunuchs of the past, the individual thus produced would be a more useful member of

<sup>1</sup> Only a few years since, I saw a young lady upon the very verge of marriage, in whom there was no trace of a uterus, and the vagina was but a slight cul-de-sac. Unfortunately, she had been placed in this unhappy position by an ignorant physician, who, unaware of the absence of the uterus, had professed to form a vagina for her, but had really laid open her urethra to the base of the bladder, leaving her with the urine constantly dribbling into a rudimentary vagina.

society, and would also be saved the degradation that so often is associated with the malformation. If this operation is done at an early age, great benefit will be obtained in this direction, and under the circumstances the loss of sexual desire will prove a blessing, as the psychical result of the defect will be less depressing, and may prevent actual insanity.

Occasionally reports are seen in both medical and popular journals citing the connection between ill-developed genital organs and congenitally deficient or removed tonsils. While such coincidences are not infrequent, yet, when we take into account the far larger number of persons whose tonsils have been excised and yet the individuals have remained abundantly fertile, we can hardly consider that the relation has been established.

In Zanzibar all boys have their tonsils excised before puberty, but atrophy of the testicles is quite unknown, and procreative power is certainly not deficient.<sup>1</sup>

#### ABSENT OR DIMINUTIVE PENIS.

The penis is rarely entirely missing, except when other serious deformities are present. Some years since, I saw a still-born child in which there were neither genitalia, arms, nor legs; and similar cases are occasionally reported,<sup>2</sup> the infants ordinarily dying in a few days.

An apparently absent penis is often found to be only a greatly diminished organ, as in spurious hermaphrodites (Fig. 1), or it is concealed beneath the integumentary folds of a cleft scrotum, or the scrotum is present and the penis buried in the fat of the mons, where it can be distinguished as a

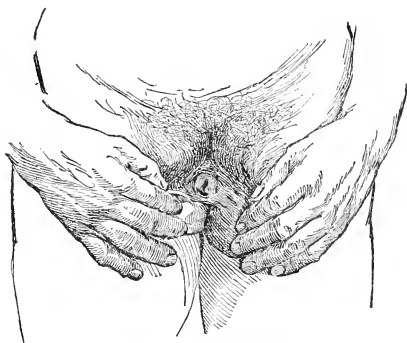

small firm cylinder. A few years since, I saw a penis thus buried that required two or three operations before it was properly liberated and fashioned.

Sometimes urine is found issuing from an orifice at the lower portion of the abdomen, in which case diligent search will disclose a concealed penis.

Occasionally the penis is absent and the scrotum present.<sup>3</sup> In such

<sup>1</sup> Trans. Clin. Soc. London, 1887, xx. 10; Brit. Med. Jour., 1881, p. 193.

<sup>2</sup> Brit. Med. Jour., 1879, ii., Pithié; Amer. Jour. Med. Sci., liii. 418; Amer. Jour. Obstet., xiv. 94; Edin. Med. Jour., xviii. 415; ib., xvi., Duncan; Lancet, 1879, i. 374; Tidy's Legal Medicine, Absence of Genitalia; St. Louis Med. and Surg. Jour., 1885, xlvi. 503.

<sup>3</sup> Brit. Med. Jour., February 23, 1889, 409.

cases the defect may have been occasioned by an imperfect fusion of the septum between the anterior or uro-genital portion and the posterior or anal portion, thus producing a broken or bridged condition of this cloacal wall. Such an imperfect closure would not only give rise to absence of the penis

FIG. 2.

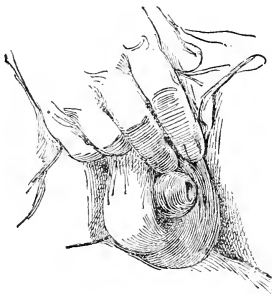

from non-appearance of the genital eminence, but might also misguide the urethra so that its orifice would be in the rectum or in some fold of skin.

In one case both penis and anus were absent, the feces returning by the mouth for forty years.<sup>1</sup>

Sometimes the body of the penis is excessively short and only the glans appears. (Fig. 2.) In very fat children where a diminutive penis is hidden by a firm and contracted prepuce, the surgeon will often be consulted in regard to this condition.

The early release of the glans, as described under Phimosis, p. 641, will usually result in the development of the organ. When the penis is buried in the scrotum or mons, it should be liberated by an incision, and an integumentary covering provided by flaps taken from the most available neighboring skin.

#### ABSENCE OF THE SCROTUM.

The scrotum is frequently altered in shape from cleavage and other causes, but it is seldom entirely absent except when multiple deformities exist. I have seen one case in a still-born child where neither scrotum, penis, vulva, nor anus existed; and a case is reported in which the left half of the scrotum containing one testicle was present, but there was no pouch upon the right side, the right testicle being concealed in the canal, without any coexistent hernia.

The concealment of the testicle in a fold of skin and its non-descent (monorchidism or cryptorchidism) are, of course, frequent conditions, and will be elsewhere discussed. In hypospadiac conditions the scrotum is sometimes scarcely distinguishable. (See Fig. 14.)

#### WEBBED PENIS.

In hypospadiac or other deformities of the genital organs the penis is sometimes bound down by a band of integument to the scrotum below<sup>2</sup> or is attached to the pubes above, in which condition it is said to be *webbed*. The organ in such cases is usually diminutive, and unless care is used in

<sup>1</sup> Agnew's Surgery, ii. 613.

<sup>2</sup> Brit. Med. Jour., September 6, 1879, p. 727, Pick.

diagnosis an error in sex may be made.<sup>1</sup> Sometimes the penis and testicles seem to be enclosed in a common pouch.<sup>2</sup>

**Treatment.**—The restraining band should be divided by an incision upon each side, so as to yield sufficient flap for an integumentary covering for the penis. The movable skin of the region will permit easy closure of the gap in the scrotum. The operation should be performed thoroughly aseptically.

#### CONGENITAL OCCLUSION OR STRICTURE OF THE URETHRA, OR IMPERFORATE URETHRA.

The meatus of the urethra is not unfrequently closed by a simple membrane,—atresia urethrae. Partial or complete obstruction of the canal by a congenital or an acquired band of tissue may also occur at any portion of its extent.<sup>3</sup> Again, the closure may be occasioned by collapse of the tube from a hypospadiac opening posteriorly, as in Ashhurst's case.<sup>4</sup> Sometimes the walls seem agglutinated through the entire length<sup>5</sup> at birth, or the corpus spongiosum is absent,<sup>6</sup> even when the penis is of considerable size.

If the stricture is within a few lines of the meatus, the stream of urine is greatly scattered and broken.<sup>7</sup>

**Treatment.**—If the obstruction is at the meatus, a simple incision, with subsequent dilatation, will suffice. Deeper in the tube, forced but careful catheterization or internal urethrotomy will best succeed.

In a case of considerable absence of the female urethra, pressure may be made beneath the pubes by a dumb-bell-shaped instrument,<sup>8</sup> in order to retain the urine.

#### CONGENITAL CYSTS OF THE PENIS.

This vice of development is rare. The pouch may connect with the urethra, as in Anger's case,<sup>9</sup> or it may be separate.<sup>10</sup> In the former case it should be excised, and the opening closed by quilled sutures. In the latter case incision and packing, to promote healing by granulation, would be advisable.

Congenital cyst of the prepuce is also occasionally met with in infants. Excision with scissors or knife is usually easy.

<sup>1</sup> Canada Lancet, Toronto, 1883-84, xvi. 134.

<sup>2</sup> Brit. Med. Jour., 1882, i. 398, 696.

<sup>3</sup> Ibid., 1887, 513.

<sup>4</sup> Amer. Jour. Obstet., ix. 504.

<sup>5</sup> Brit. Med. Jour., 1885, i. 17; Cincinnati Obstet. Gazette, 1880, p. 57.

<sup>6</sup> Med. and Surg. Reporter, Phila., 1883, xlix. 585; Journal of Cutaneous and Venereal Diseases, New York, 1885, iii. 8.

<sup>7</sup> Daniels, Texas Journal, 1886, p. 355; College and Clinical Record, Philadelphia, 1886, vii. 10.

<sup>8</sup> Amer. Jour. Obstet., v. 147.

<sup>9</sup> International Encyclopedia of Surgery, Ashhurst, vol. vi. p. 486, 1886.

<sup>10</sup> London Lancet, 1884, ii. 773; Trans. Clin. Soc. London, 1886, xix. 325; Traité pratique des Maladies des Nouveaux-nés, 1867, 641.

## ADHERENT PREPUCE, AND ELONGATED, CONTRACTED PREPUCE, OR PHIMOSIS.

Adhesion of the prepuce and contraction of the prepuce are two distinct conditions, although they frequently coexist.

*Adhesion* is almost constantly present at birth, as a continuation of the normal intra-uterine agglutination, occasioned simply by a failure of the cells of the rete Malpighii sufficiently to condense or harden. During the first weeks of life this union is so slight that it can be separated with the greatest ease. In time it may become quite firm, as a result of slight inflammation.

A *contracted prepuce, phimosis* (*φίμωσις*, "I bind"), rarely exists at birth, but is the result of an inflammatory condensation of preputial tissues.

FIG. 3.



Elongation is ordinarily a later result. (Fig. 3.) When an attempt is made to retract an adherent foreskin the orifice will seem to be at first almost pin-hole in size, but after a moment's manipulation slight rigidity of the penis will occur, and soon the reddened meatus will appear.

In a circle just behind this or at some point in the circumference of the glans will be found the line of adhesion. In contracted cases it may be impossible to expose the glans, but exposure is feasible in a far larger proportion of cases than is ordinarily apparent at first sight. I have shown in other writings how easily this is secured by patient manipulation.<sup>1</sup>

Atresia præputii tends by pressure upon the glans to dwarf its growth, and adhesion necessitates the accumulation of smegma, which may harden and act as a foreign body.

**Reflex Nervous Disturbances from Genital Irritation.**

—To Sayre<sup>2</sup> is due the credit of prominently bringing before the profession the reflex nervous disturbances due to the irritation of retained smegma and to the presence of a contracted foreskin upon the balanitic structure. Pursuing the subject with his usual vigor, circumcision became the cure for every nervous condition with rash and unthinking practitioners, until he himself was compelled to "call a halt."<sup>3</sup>

Even to summarize what has been written upon this subject would fill a volume,<sup>4</sup> but it is now very generally conceded (1) that genital irritation is frequently the cause of various reflex nervous, choreic, or parietic conditions, and (2) that the removal of this condition by the various means hereafter mentioned is frequently curative, and is almost always beneficial.

<sup>1</sup> Archives of Pediatrics, 1886, iii. 385; Phila. Med. and Surg. Reporter, July 25 and August 1, 1885; Phila. Med. Times, June 30, 1883; Trans. Ninth Internat. Med. Congress, Washington, 1887, vol. iii. p. 473.

<sup>2</sup> Trans. Amer. Med. Assoc., 1870.

<sup>3</sup> Trans. Ninth Internat. Med. Congress, Washington, 1887, vol. iii. p. 462.

<sup>4</sup> Phila. Med. Times, June 30, 1883; New York Med. Times, September, 1884.

Neuroses dependent upon reflected irritation from stomach, eye, nose, uterus, etc., are frequent. The genital nerves are confessedly the most sensitive of any in the body, and both the anatomical<sup>1</sup> and the physiological explanations of reflected results are simple.

The most common of these results are incoördinate and choreic movements of the limbs, paresis, feeble muscular action, malnutrition, convulsions, epilepsy, dysuria, nocturnal incontinence, prolapse of the rectum, and hernia. Symptoms resembling those of stone in the bladder are not uncommon, and hip-disease,<sup>2</sup> spinal caries, and bow-legs have been attributed to this cause. In the latter cases the result can be thus referable only through the influence upon general nutrition.<sup>3</sup>

In young infants many cases of restlessness at night, of defective nutrition, and of malassimilation have been greatly benefited by attention to the genital organs, and the puny, irritable, wakeful boy has been rendered plump and happy by simply giving him a clean, exposable glans penis.

Even when the amount of retained smegma is not large the uncleanness of the parts will often set up severe vesical irritation, and is also conducive to priapism and masturbation.

Occasionally the loss of muscular power does not involve all the muscles of the lower extremities, but only one group, thus simulating club-foot or other deformity.<sup>4</sup>

Another reflex symptom recently noted is epistaxis,<sup>5</sup> probably due to the relation existing between the genital organs and the varicose venous plexuses of the nasal mucous membrane, which closely resemble erectile tissue, as demonstrated by Ischwell, Elsberg, and others. In lower animals this association may be even more intimate. Reflex cough and convulsions are common.<sup>6</sup>

No physician is justified in overlooking this causal element of disease, and in every obscure case a careful investigation of the state of the genital organs should be instituted: in fact, it would be the part of wisdom to ascertain in every male child the fact that the prepuce and the glans are separable. If family practitioners would gently separate the delicate adhesions in all young male babies, a vast amount of good would result.

**Acquired phimosis** is found in large boys, from balanitis or other inflammatory troubles, especially gonorrhœal.

**Diagnosis and Prognosis.**—A diagnosis of the actual condition is usually easily made, but upon its degree will depend the question of treatment. The method of testing the exposure of the glans has been already described.

<sup>1</sup> Trans. Ninth Internat. Med. Congress, Washington, 1887, vol. iii. p. 471.

<sup>2</sup> Barwell, *Diseases of Joints*, 2d ed., 1881, 289.

<sup>3</sup> New York Medical Abstract, July, 1888; Rev. Méd. de la Suisse Romande, 1888.

<sup>4</sup> Agnew's Surgery, 1st ed., vol. ii. p. 427.

<sup>5</sup> Archives of Pediatrics, November, 1888; Rev. Mens. des Mal. de l'Enf., June, 1888.

<sup>6</sup> Lancet, April 27, 1889, p. 835.

The diagnosis of the relation of the genital irritation to the reflex symptoms when they are present will, however, require careful study. In general terms, if the contraction is great, the adhesion firm, the accumulations of smegma large and hard, and the orifice of the urethra very sensitive, it is quite probable that these conditions bear a causal relation to the reflex symptoms.

Even when these conditions are present, however, it must be remembered that they may be but one factor in the case, and that other causes must be earnestly sought. Too frequently a serious brain or spinal lesion has been overlooked simply because the boy had an adherent prepuce, the practitioner apparently forgetting that nearly all boys have this condition.

To promise an immediate gain in muscular power when feeble action is due to deficient central nerve-cells is but to lose the confidence of the patient and bring discredit upon the operation. While such feeble or idiotic children should be given the benefit of the doubt, that genital irritation might be an element in the production of their condition, yet the prognosis should be guarded and central causes should be thoroughly investigated and treated.

While, therefore, a freely-moving prepuce or an uncovered glans should be secured *in every case where reflex symptoms arise*, yet the prognosis should be varied according to the other existing conditions.

In girls with irritation or hyperæsthesia of clitoris or nymphæ, incoördinate movements are sometimes seen, but the prognosis of recovery after separation of adhesions is not so favorable.

**Selection of Operation.**—In deciding upon the method of relief in any case, the surgeon must clearly differentiate the two classes of cases,—*i.e.*, those of *adhesion* and those of *contraction*. He must also settle clearly in his own mind the desirability of a covered or of an uncovered glans. To attain to the normal standard is to secure a *prepuce moving freely over a healthy glans*. The foreskin is intended to protect the head of the organ during the years when the penis is but a portion of the urinary apparatus, and later by its friction over the sensitive corona to enhance the ejaculatory orgasm.

If removed earlier than intended, a progressive sclerosis or hardening of the glans occurs, and the evils of contracted meatus, balanitis, etc., follow, as pointed out by Otis, Mastin, and others.<sup>1</sup>

I have failed to find any statistics proving that the circumcised masturbate less frequently or are more virtuous than others, and the exposure of the tender skin to friction of clothing, etc., tends to keep up a state of abnormal excitement during the early years of life.

The sulcus after circumcision is no more cleanly than the one that is daily washed, and such washings should be always insisted upon in the case of children. When carefully done by the mother, and not by the nurse, it occasions no excitement, and is the best of preventives against masturbation

<sup>1</sup> Archives of Pediatrics, 1886, iii. 388.



and priapism. It is as important to be continued through life as is the washing of face or hands, and after a few days' practice no more excitement is aroused even in adults than by the handling of the organ in urination. If commenced in youth it is looked upon as an ordinary act of cleanliness and will prove most hygienic. Even if it were the duty of the surgeon, as some operators allege, to prepare boys for future vile intercourse, such an individual is no more free from danger of contagion than the one who has thoroughly cleansed his exposable glans, since cicatricial tissue is always the tissue that is the least resistant to infection. It is for this reason that the prepuce should be retained whenever it can be made freely movable, since when cleanly it is of great advantage to the individual.

Its removal is a mutilation. It is idle to argue that because imposed in the Mosaic law it is therefore hygienic. Circumcision was instituted solely as a religious rite long before the time of Moses, and was intended to mark distinctively "the peculiar people." Its adoption by other nations may very probably have been in the hope of securing the blessings that were poured so bountifully upon this people by Jehovah. Such mutilations were not uncommon among barbarous tribes, and, as this mark was the only visible sign of difference, superstition could have easily induced thousands to submit to its practice. In this manner the practice may have extended to widely remote people.

Whenever possible to "strip" the glans and secure a freely movable prepuce, it should be the operation chosen, since of two operations equally efficient the simpler one should be selected. In new-born children this method is nearly always feasible, and in a large proportion of all young children it will be found an easy one. As a rule, this separation is accomplished by the boy's own manipulations before he is eight years old; but it is better that it should be done by the physician in infancy.

When contraction is slight, single or multiple incision of the mucous face is preferable to dilatation, although the latter may be practised if there is great fear of the knife. The inflammatory thickening following both incision, and dilatation to the point of rupture of mucous membrane, is undesirable if it can be avoided.

Finally, in all cases where reflex symptoms arise and where other plans fail to give the easily-sliding prepuce, circumcision should be performed. This operation as later described, and when practised *discriminatively*, is a most valuable agent.

The dangers of this plan are greater than those by the other methods, and deaths have resulted. Kohn alone saw six. In large boys and adults, when contraction has become established any operation short of circumcision is rarely useful, and these cases almost invariably require the removal of the entire mucous face of the prepuce.

**Treatment.**—1. *Stripping the Glans.*—The relief of simple adherent prepuce in a young infant requires no instrument. All that is necessary, after slight rigidity has taken place from manipulation, is to draw the fore-

skin slowly backward until the point of adhesion is reached. This exposure may sometimes require a full minute, or even more. Then the penis is to be grasped between the thumbs of the operator, while his fingers support the sides of the organ, when gentle backward rubbing or traction upon the

FIG. 4.

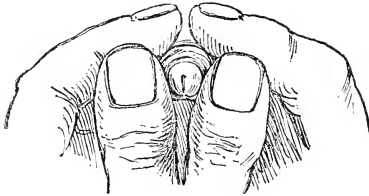

margin of the rim will strip the prepuce from the glans as easily as the rind is peeled from the pulp of an orange. (Fig. 4.)

The same procedure (or, if preferred, two fingers may be placed upon each side of the organ) is applicable in the majority of cases of adhesion in older children, save that a probe or a grooved director is sometimes

necessary to break up the union when it has become more decided. Only in older inflammatory cases will a dissection become necessary. The separation should be carried back until the sulcus behind the corona is fully exposed, when all smegma should be thoroughly wiped and scraped away and a small ring of borated or salicylated cotton dipped in cosmoline is made to encircle loosely the neck.

The removal of smegma is sometimes very difficult, as some of the particles of almost chalky or sandy hardness adhere with great tenacity. The flat end of a probe or an ear-scoop will best dislodge them.

The dressing should be at hand, since if the prepuce is allowed to remain long behind the corona, paraphimosis may result and great difficulty be experienced in reduction. A couple of probes or hair-pins will in such case assist greatly in compressing the glans and in bringing the foreskin forward. Of course it must never be allowed to remain retracted, lest sloughing result.

The foreskin should be slid back and forth several times, to see that it moves easily.

The cotton is allowed to remain *in situ* for several days, when it is removed, the parts thoroughly washed with one to ten-thousand sublimate solution, and the dressing applied as before.

After the tenth day the prepuce should be retracted daily by the mother of the child, and the parts washed clean, for reasons that have been explained on p. 640. This washing should be continued daily *for the remainder of life*.

After a surgeon has practised this method a few times its simplicity and efficiency will so recommend it to his practice that he will circumcise only about half as many cases as formerly. Cases which at first seem to him intractable soon yield, and the glans is exposed.

Ether is rarely required, but cocaine is useful.

The rule should be always to secure a *freely movable prepuce*; and if the

narrowing be such as to render retraction impossible, other means must be employed.

2. *Dilatation*.—This may be accomplished by an ordinary pair of dissecting- or of dressing-forceps, or by a uterine dilator, or, better, by one of the two-bladed or three-bladed dilating forceps<sup>1</sup> that have been designed especially for this purpose.

FIG. 5.

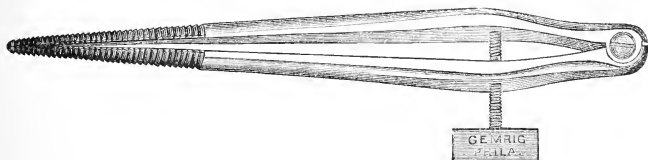

Levis's pattern, as shown in Fig. 5, depends upon screw-power for opening the jaws, and is very effective. Slow dilatation by tents or by forceps applied for twenty minutes twice daily will accomplish the purpose where time is not an element in the treatment<sup>2</sup> and where the knife is refused.

The disadvantage of forcible dilatation lies in the subsequent thickening and induration of the mucous membrane. This plan is largely practised, and is a valuable assistant to "stripping" in the more difficult grade of cases.

3. *Slitting*.—When the foreskin refuses to glide backward after adhesions are separated, slight incisions may be made to relieve the contraction that exists in the inner face of the prepuce. A probe-pointed straight bistoury is carried along a grooved director into the firmly-retracted opening, and with its back towards the glans several superficial nicks are made in the mucous surface of the prepuce. The guide for cutting will be to divide the most rigid parts until the hood slides freely over the glans.

Preliminary packing of the pouch with cotton saturated with cocaine solution will often obviate the necessity for ether, especially if the knife be concealed from the view of the child.

The dressing and subsequent treatment should be the same as in stripping.

*Circumcision*.—The method of performing circumcision will depend upon the amount of redundant skin. If long, it was formerly removed as in the Rabbinical manner,—*i.e.*, by drawing forward the prepuce, and severing it with one stroke of the knife, either with or without protection of the glans by a slit ivory or silver guard. The mucous face is then torn back and all the tissues pushed fully back of the corona. Hemorrhage, sloughing, and sometimes death have been the results of this practice. The arrest of hemorrhage by placing the penis in the wine-filled mouth of the Rabbi has

<sup>1</sup> Phila. Med. and Surg. Reporter, February 2, 1884, p. 137.

<sup>2</sup> Brit. Med. Jour., 1879, ii. 86; Trans. Ninth Internat. Med. Congress, 1887, vol. iii. pp. 459, 475.

been discontinued, as syphilis was thus easily communicated to the fresh surface. This dangerous practice has been abolished by the Paris Israelites, and, by the recent decree of the Commission of Surgeons acting in connection with the Grand Rabbi, many essential rules enforcing the strictest cleanliness of the Rabbis, infants, and instruments, have been adopted.<sup>1</sup> In hemorrhagic cases it has long been the custom after two deaths in a family to omit the operation. The repugnance to the mutilation is increasing to such an extent that certain Rabbis have ceased to insist upon it as a religious rite.

Circumcision is performed by the surgeon in a variety of ways, and there have been devised many special forceps (Velpéau's, Skilling's, etc.),—some with fenestrated blades, some with peculiar clamps, others designed to permit the easy introduction of sutures, etc.,—but all of them are entirely unnecessary. Any forceps provided with parallel-closing blades so as to hold evenly the entire width of the foreskin is all that is needed. Figs. 6 and 7 are convenient forms.

FIG. 6.

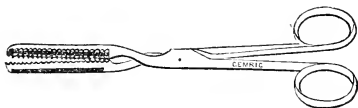

FIG. 7.



Ether is advisable, but, if there is any special objection to its use, partial local anaesthesia can be secured by ice, by ether spray, or by packing the foreskin both inside and out with cotton soaked in a four-per-cent. solution of cocaine for ten minutes and then inserting five or six hypodermic injections into the prepuce with the same solution, the effect being enhanced by the encircling of the penis at its base with a rubber band.

Not more than one-half to three-fourths of a grain of cocaine should be introduced beneath the skin, even in adults, lest poisoning follow. Deaths have resulted from a neglect of this rule. Cocaine is badly borne by the genito-urinary tract.<sup>2</sup>

Absolute cleanliness is imperative.

The prepuce is retracted so that its mucous surface can be seized, preferably with roughened forceps like Levis's (see Fig. 5), and drawn well forward. If tension is made upon the skin instead of on the mucous face as described, it may readily be drawn so far forward that even the integument over the corpora may be removed. The best plan is to sacrifice as little as

<sup>1</sup> *Annales d'Hygiène*, October, 1888; *Jour. Amer. Med. Assoc.*, October 20, 1888, p. 576.

<sup>2</sup> *University Medical Magazine*, August, 1889, p. 638.

possible of the integumentary surface, as it is all needed as a covering for the glans.

While the mucous surface is made tense *and the skin retracted*, the whole is firmly grasped by forceps *slanting forward* from the dorsum towards the frænum, so as to remove a smaller portion in the latter region (Fig. 8).

FIG. 8.

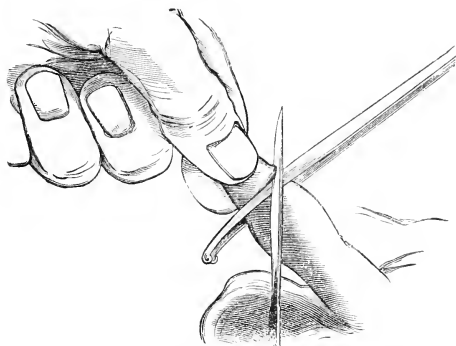

Prepuce embraced with the forceps preparatory to cutting off. (Agnew.)

The section should be made in front of the forceps with a very sharp knife. The galvano-cautery has also been used.

Upon releasing the part, a portion of the mucous surface will still enclose the glans like a cap. This must be slit up and trimmed away nearly to the corona, so that the sulcus will be fully exposed.

After cleansing with one to five-thousand sublimate solution, and ligating with fine catgut any freely-bleeding points, lest the hemorrhage dissect up the loose tissue and interfere with union, the skin and mucous surfaces are united at five or six points by catgut or iron-dyed silk sutures (Fig. 9).

The gut stitches are preferable, as even so painless an operation as the removal of the threads is a terror to children and will make them unhappy for days. Silver wire or serres-fines should never be used. The wound is again thoroughly disinfected and the part wrapped in gauze wet in one to ten-thousand sublimate solution. About the penis is then fashioned a nest of borated or salicylated cotton or wool, and a diaper applied as a retaining bandage, even in large children, so as to keep the penis upright. After each urination, if the dressings are soiled the parts should be thoroughly disinfected and the dressing applied as before. Union will be speedy and non-suppurative.

FIG. 9.

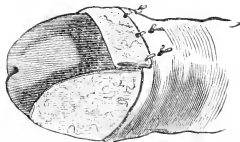

Mucous membrane slit up and one side reflected and stitched to the skin of the prepuce. (Agnew.)

Without the intervention of gauze the wool or cotton adheres too closely to the part. Close attention to minutiae will save much pain and fright.

Another modification of circumcision in atrophic cases, where there is no great redundancy, is by *dorsal incision* of the prepuce. A probe or grooved director is first introduced, to sever adhesions and prevent the possibility of incising the urethra.

The section can be made by carrying a sharp bistoury along the director, puncturing the firmly-retracted skin at the corona, and dividing from before backward; or it can be made with scissors with one blunt point, like Taylor's.<sup>1</sup> The mucous surface is then thoroughly freed, the corners rounded off, and stitches applied as before (Fig. 10). The angles should never be left to form disfiguring flaps on each side of the penis. Liston made the section near the frenum, so as to retain the skin upon the glans, which is of advantage, and Jobert, Taylor, and others have operated similarly. Hue's plan of the *elastic ligature* and that of the *écraseur* are too tedious and painful, and should never be used except in hemorrhagic cases, and even then gradual dilatation is better.

FIG. 10.

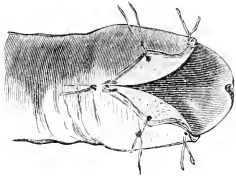

Operation by incision. Skin and mucous membrane slit up and united by the interrupted sutures. (Aguew.)

In girls it is rarely found that any serious operation is necessary. The nymphæ are seldom so firmly adherent either to each other or to the labia majora that they cannot be separated by the exercise of a small amount of force. The hood of the clitoris can also be drawn back in the same manner by the fingers of the operator, and a dissection is rarely required. Temporary separation of the surfaces by borated cotton, and subsequent cleanliness after each urination, will be all the dressing that is required, but the surgeon should examine the case for several weeks, lest readhesion occur.

#### PARAPHIMOSIS.

Paraphimosis (*παρά*, "amiss," and *επιόω*, "I bind") is a condition in which an abnormally narrowed prepuce becomes retracted behind the corona and remains there irreducible. It may also be produced by great swelling of the glans after injury, even when the foreskin is normal.

The condition is usually found in children as the result of their own or other lewd boys' action in forcing back the prepuce before it is thoroughly freed from the glans, or from placing strings, bands, etc., around it. In larger boys it frequently follows attempts at coitus. It has not unfrequently happened in the hands of physicians who have retracted the skin in balanitis to obtain a view of the glans.

The constriction at the neck of the penis speedily interferes with circu-

<sup>1</sup> Bunstead, Venereal Diseases, 5th ed.

lation, and both glans and prepuce become enormously swollen. The resulting inflammation may progress even to gangrene.

**Treatment.**—A. *Manual Methods.*—The indications to be fulfilled in reduction are—(a) to reduce the size of the glans, (b) to draw forward the contracted prepuce, and (c) to reduce the consequent inflammation.

1. The lateral folds of skin may be grasped on each side by the surgeon with thumb and finger, the two thumbs thus acting as compressors of the glans while forward traction is made by thumb and finger on the contracted ring.

2. The engorged glans may be reduced by a spirally-applied band of rubber, which band, being continued up upon the body of the penis, may then be simultaneously unwound and withdrawn so as to slide the prepuce forward.

3. The glans is compressed by the thumb and fingers of one hand while the other hand draws forward the prepuce (Fig. 11), or the glans is compressed by the dorsums of both thumbs while four or more fingers are employed as tractors.

4. The glans is compressed by the firm

FIG. 11.



Phillips's method of reducing paraphimosis.

FIG. 12.

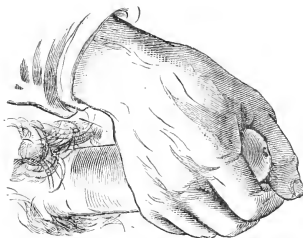

Agnew's method of reducing paraphimosis.

grasp of the surgeon's hand for several minutes, after which the same hand is used to draw forward the foreskin (Fig. 12).

B. *Operative Measures.*—Should the surgeon fail to reduce the condition, or should the constriction have become indurated, it should be divided on the dorsum by slipping beneath it a blunt-pointed bistoury and relieving it freely (Fig. 13). The small hemorrhage will unload the vessels, and reduction will be easy.

FIG. 13.



The best subsequent dressing in all cases will be laudanum and ice-water, to which may be added any mild disinfectant, as boracic acid. Ice

and cocaine freely applied will render all the manipulations much less painful, provided ether be not used. The pain is so great, however, that, unless it is desired to make an impression upon the mind of a lewd boy, anaesthesia should be employed.

After the reduction of the inflammation, if the foreskin does not slide with perfect ease, circumcision should be performed.

#### HYPOSPADIA.

Hypospadias (*ὕπoς*, "under," and *σπáζω*, "to open"), as named by Galen and subsequently minutely described by Dupuytren, is a deficiency of the urethra in which the outlet of the tube is present at some abnormal point between the extremity of the glans penis and the perineum.

**Etiology and Pathogenesis.**—This condition may be occasioned (1) by the absence of a portion of the lower wall of the urethra, (2) by a failure in coalescence of the lateral halves of the tube, or (3) by the rupture of the thin pouch which is usually known as a congenital dilatation of the urethra, thus creating what is really a congenital fistule. The arrest of development may be so slight as to show only the loss of the portion of the tube beneath the glans, constituting the *balanic* variety, or the opening may be

FIG. 14.

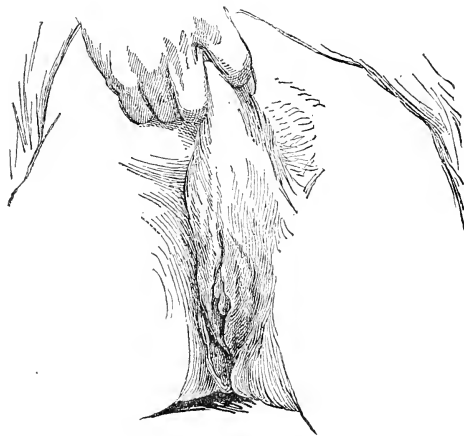

*corporeal*, *scrotal*, or *perineal* (Fig. 14), names that are indicative of the point of exit.

The extent of deficiency will depend upon the degree of arrest in the development of the superior or inferior genital buds of Coste.

As the fusion of the lips of the genital groove arising from the urogenital sinus takes place from the perineum forward, it follows that the



anterior portion is the point most frequently wanting. This fact of origin explains the persistent vulvar conformation in hypospadiac males, since it indicates an arrest of development of the inferior genital buds at the time when differentiation takes place.<sup>1</sup>

Rarely will the mal-control of formation cease at the absence of the lower wall, of the urethra alone, but deformities of penis, bladder, serotum, and pubic bones will often coexist.

This vice of conformation is often hereditary. Woodman saw it in four generations, but only on the male side of the family, the male children of daughters being well formed.

Bouisson puts the frequency of hypospadias as once in every three hundred children born; but in my experience his estimate is too high.

The balanic variety, in which the opening exists beneath or just behind the glans, is the form most commonly found,<sup>2</sup> the imperfect track of the urethra being marked by a shallow sulcus along the under surface of the glans, in which groove I have once noted a small false pocket.

An opening at this point is rendered more serious, as regards copulation and fecundation, by the frequent occurrence of a coexistent short corpus spongiosum, and by dense bands near the abnormal opening that bend the head of the organ sharply downward over the orifice during erection (Fig. 15).

A redundant preputial hood, partially adherent to the glans, often conceals the head of the penis. Sometimes there is a double meatus,<sup>3</sup> or the opening may exist at one side of the corona.<sup>4</sup>

In the corporeal variety the opening is usually larger, and the tube may exist in front of the orifice, the fistule possibly being due to a ruptured urethral pouch.

When the opening is scrotal or perineal, it is usually accompanied by cleft scrotum, and frequently by non-descent of the testes. The penis is often dwarfed, twisted, bifid, flattened, webbed, or even concealed in integumentary folds resembling labia.

When it is remembered that during the development from the genital buds there is at first no apparent difference in the two sexes, it will not seem strange that in the malformation of these parts great confusion may

FIG. 15.

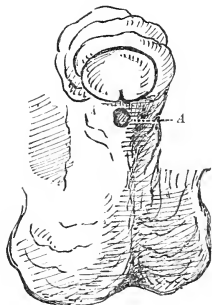

GLANS INCURVED BY SHORT CORPUS SPONGIOSUM.—A, meatus shown expanded.

<sup>1</sup> International Encyclopaedia of Surgery, Ashurst, 1886, vi. 489; Bökal, Jahrbuch f. Kinderheilk., Leipsic, 1888, xxviii. 138; Voituriez, Bull. Soc. Anat.-Chir. de Lille, 1887, ii. 101.

<sup>2</sup> Cristiani, Rev. Méd. de la Suisse Rom., Genève, 1889, ix. 313.

<sup>3</sup> Phila. Med. Times, 1877, 310; Virginia Med. Monthly, February, 1877; North Carolina Med. Monthly, 1887, ix. 62; New England Med. Monthly, 1882, iv. 196.

<sup>4</sup> London Lancet, 1884, ii. 773.

exist and the sex of the individual be very uncertain.<sup>1</sup> The further discussion of this subject will be found under Hermaphroditism, p. 669.

When the meatus is perineal, unless urination is performed in the position assumed by females the protection of the clothing is impossible.

Vesical irritation, eczema, and herpes præputialis are often troublesome. Sometimes the hypospadiac opening forms a common opening for both urine and feces.<sup>2</sup>

At death the majority of pseudo-females are found to have been hypospadiac males.<sup>3</sup>

**Diagnosis.**—The discovery of the abnormal opening is rarely difficult, especially if the act of urination is watched.

The determination of the sex of a new-born babe with perineal hypospadias and other genital deformities will often be difficult, owing to the exceeding smallness of cavities and organs and the difficulties of exploration. The discussion of this problem is continued under Hermaphroditism, p. 669.

**Prognosis.**—The prospect of cure will depend not only upon the degree of the deformity, but also upon the patience, perseverance, and determination of the patient. When the orifice is at or near the glans and there is no incurvation during erection, the inconvenience is but slight and the future man will doubtless be fruitful. No operation is necessary, therefore, except for the sake of appearance. Fecundation is also possible when the opening is in the anterior part of the corporeal region. In the scrotal and perineal varieties ejaculation can take place only upon the vulva of the female, unless future mechanical skill shall construct a tube that can be used for elongating the urethra. If a penis of moderate size, however, be present, it is possible to construct a real urethra upon its under surface, even when the orifice is far back. Of course many failures will occur, and from two to six successive stages are often necessary, even in moderate cases. Every surgeon familiar with this class of operations knows, from repeated disappointments, that great patience is required even in simple cases. In children the diminutive character of the penis, the thinness of the raw edge of the skin-flaps, and the constant presence of urine, whether a catheter is used or not, make success always doubtful without frequent operations.

**Treatment.**—*Time for Operation.*—The general rules governing operation, as advised on p. 633, will apply in hypospadias. It is unwise to operate upon a young babe so long as there is no difficulty with urination, since the diseases of early infancy may readily cause death before serious mental or physical annoyance is experienced.

In order to facilitate the proper growth of the penis, the adherent pre-

<sup>1</sup> Voituriez, Bull. Soc. Anat.-Chir. de Lille, 1887, ii. 101; Schuryzin, Protok. zazaid. Karkasek. Med. Obsh. Tiflis, 1887-88, xxiv. 476.

<sup>2</sup> St. Thomas's Hosp. Reports, ix. 29-35; Vrolik, Tabule Embry. Hominis, etc., 1849, Table 31; Nagel, Archives Générales de Médecine, tome ix. p. 580, 1857; Brit. Med. Jour., Oct. 20, 1888; also Bost. Med. and Surg. Jour., 1888, cxviii. 375.

<sup>3</sup> Trans. Path. Soc. Lond., 1884, xxxvi. 309.

putial hood, if present, should be stripped from the glans very early in life, but the tissue of the redundant hood (Fig. 16) should not be sacrificed until the completion of operative measures, since it may be necessary to utilize it for plastic flaps.<sup>1</sup>

All surgeons who have had practical experience have learned that success is best attained by dividing the operative procedures into several stages.

1. *Straightening the Penis.*—This is accomplished by multiple open and subcutaneous incision of all restraining bands, whether they exist in the corpus spongiosum, in the cavernosa, or in the septum.

An encircling cylinder of adhesive plaster will assist in preventing retraction. When soiled, this should be washed with one to ten-thousand sublimate solution, or with boracic acid.

2. *Deepening the Groove.*—If the groove in the glans is too shallow to permit of the formation of a new urethra, or if the glans remains flexed, the furrow should be deepened by incising so freely into the substance of the glans that the resultant meatus will be on a straight line with the normal urethra. This incision may be median and single (Fig. 17), or multiple and branching (Fig. 18), the mucous membrane being undercut in order to prevent contraction during healing. This contraction is so exceedingly difficult to prevent that I now delay it until I am ready to proceed to the third stage of the operation.

FIG. 16.



Redundant prepuce partially concealing the glans.

FIG. 17.

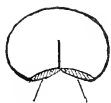

FIG. 18.



FIG. 19.



The old plan of tunnelling through the tissues with a hot wire has been nearly abandoned, although it is still occasionally attempted.<sup>2</sup>

It would be easier to produce such a pathway with the thermo-cautery, or with an instrument like a harness-maker's punch.

The bleeding from an incision, even when a considerable portion of glans-substance has been cut away, while free after the removal of the rubber tourniquet, is not dangerous, and can be controlled by pressure made upon an inserted catheter. If the groove is not deepened in this manner, failure will often occur in the formation of a new urethra by too great ten-

<sup>1</sup> Hardin, Manchester Medical Chronicle, 1889, x. 384.

<sup>2</sup> Australian Medical Journal, 1886, viii. 390.

sion on the flaps. The sulcus is usually so shallow that many failures have occurred from the timidity of the operator.

Union is secured by fastening the lips over a section of a catheter by shotted wire sutures or by a pin (Fig. 19).

3. *Formation of a New Canal from the Extremity of the Glans to the False Opening.*—There are several methods of forming flaps for this purpose. An excellent one is the fashioning of one long and one short flap. The former is made by carrying an incision parallel to the course of the urethra as far outside the margin of the defective groove as the size of the penis will permit (Fig. 20, *A*). This flap is dissected inward towards the median line. A second incision, *B*, is now made just outside the line of the gutter on the opposite side, and a short flap is raised by dissection outward away from the median line. The long flap is then reverted over a catheter as a mould, the raw surface being left outward, and is tucked beneath the short flap, where it is secured by aseptic black silk or by catgut sutures.

FIG. 20.

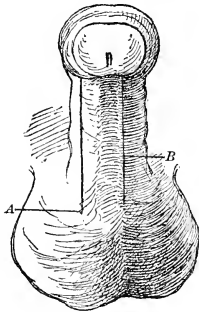

Another plan, that of Duplay, is an exceedingly good one. With a catheter for a mould, two longitudinal incisions are made along the proposed line of the tube, at equal distances from the median line and about three millimetres from it, extending from the extremity of the glans to the anterior curve of the hypospadiac opening. From these incisions short flaps are dissected inwardly, so that even after retraction they will still cover one-third or one-half of the catheter. Outwardly from these incisions the dissection is freely carried far enough to give an easy covering of skin for the catheter from the sides of the penis. When these parts are brought together, there will be four flaps, two short ones (Fig. 21, *A* and *B*), with bases looking towards the median line and with their epithelium-covered faces lying upon the catheter to form the bottom of the urethra. The two longer ones (*C* and *D*, Fig. 21), with bases attached near the inferior lateral portions of the penis and with raw surfaces inward, are superimposed and united to complete the new tube. A quilled suture is made by passing single wires through the edges of the long flaps and then shooting them over a perforated lead strip. Any further needed skin-approximation is made by shallow interrupted sutures.

FIG. 21.

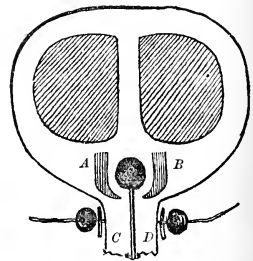

Schematic plan of four flaps.

The catheter or a section of soft drainage-tube is allowed to remain in the anterior urethra for a few days, and the urine is passed as neces-

sary through the false opening. The sutures should be removed on the fifth or sixth day, unless they occasion earlier irritation. When the sulcus in the glans has been deepened, this tube is a necessity to prevent contraction.

Another plan is to cut two wide longitudinal flaps with bases corresponding to the edges of the urethral gutter. Turning these with skin surfaces towards the urethra, their edges are united with fine, interrupted, thoroughly aseptic catgut sutures, the ends of which are left uncut.

To cover these raw surfaces flaps are taken from a redundant prepuce or scrotum, or the penis may be pushed through a slit made in the prepuce and the skin utilized as a flap. These superimposed flaps are to be sutured with their raw faces against the denuded surfaces of the first flaps by means of the free ends of the previous catgut stitches which have been left uncut for this purpose.

For cosmetic effect subsequent trimming will probably be necessary.

Preferably several months later, when all tendency to contraction of the urethra has certainly passed, the fourth step is to be made.

4. *Closure of the Hypospadiac Opening.*—This will be accomplished by thoroughly paring the entire circumference of the gap and then drawing across it two flaps made as in any of the previous methods, and uniting them in the same way,—urethrorrhaphy or urethroplasty. At the option of the operator a catheter may be retained in the bladder and left open for three days, provided it does not produce irritation. After that time the urine may be passed naturally, care being taken to support the wound gently and to cleanse the line of incision thoroughly after each urination by a one to ten-thousand solution of corrosive sublimate.

Erections must be controlled by opium, bromides, camphor, or lupulin.

Subsequent contraction of the urethra must be overcome by progressive dilatation.

The chief cause of failure in union, aside from the necessary presence of urine, is found in the fact that young operators are timid about cutting long flaps, and thus too much tension is brought to bear upon the tissues.

The question as to the retention of a catheter in a plastic operation on the urethra is one that has puzzled all surgeons. The instrument is painful and annoying to the child, and not infrequently it produces cystitis. It does not accomplish the purpose for which it is designed, as the urine not only issues alongside of it but also follows back along its outer surface, and the wound is frequently drenched. It also becomes speedily encrusted or blocked. Until the final step of closing the abnormal opening is reached, I have, therefore, discarded it entirely. A section of catheter—or, better, a piece of soft drainage-tube, since it gives less pain in the movements of the child—is left in the anterior urethra for a few days, while urination is performed through the hypospadiac opening, light pressure preventing the urine from passing forward. The sole use of the tube is to retain the patency of the canal. The parts are to be cleansed and rendered aseptic after each urina-

tion. Even when the final closure of the hypospadiac orifice is undertaken, I have found that the catheter is often worse than useless in children, and that careful support of the wound during urination answers far better. Catheterization of a frightened child with a sore urethra is neither safe nor possible, even with cocaine, and it must always be remembered that this drug seems to have peculiarly serious effects when used in this region.

In severe cases with perineal opening and cleft scrotum, resembling hermaphroditism, a careful study of each case must be made, as plastic surgery may be able in a limited number of cases to secure such improvement of condition that subsequent marriage will be permissible.

When the penis is present, even though diminutive, it may be quite feasible to construct a urethra along its under surface. Mechanical art may sometimes provide a tube which can be inserted into the short urethra and act as a conductor of the semen to the os uteri in those cases where a hypospadiac individual has been rash enough to contract marriage. In such a case also the plan of collecting the semen and injecting it into the cavity of the uterus by a syringe would be justifiable.<sup>1</sup>

If the child is careful to support the newly-constructed portion of the urethra by a judicious application of his fingers, he can do much, during the week following the removal of the stitches, to prevent a rupture of the delicate union.

#### CONGENITAL URETHRAL FISTULE.

In connection with hypospadias should be mentioned *congenital urethral fistule*, since it is a deformity occasioned by the same cause,—that is, a want of union at some portion of the lips of the urethral groove of the urogenital sinus. It may also be caused by a temporary or permanent closure of the anterior portion of the canal and the consequent rupture of an obstructive cyst.

Occasionally a congenital fistule permits the passage of both urine and feces.<sup>2</sup>

A persistent Müllerian duct opening near the floor of the female urethra may resemble a fistule.<sup>3</sup> In these cases the retrograded Wolffian body is represented by cysts, the hydatid of Morgagni and the organ of Giraldes both being present.

Imperfect fusion of these Wolffian bodies produces many anomalies besides fistule, since errors of development or of union may occur at any point in their course as they extend downward from the rudimentary diaphragm in the fetus to the exit from the pelvis.<sup>4</sup>

<sup>1</sup> Med. Press, July 18, 1888; Phila. Med. News, September 8, 1888, 279; Leçons de Gynécologie opérative, 1889.

<sup>2</sup> New York Med. Record, 1880, xviii. 202; London Lancet, 1883, ii. 986; Edinburgh Med. Jour., 1884, xxx. 118-120.

<sup>3</sup> Royal Med.-Chir. Soc. Lond., 1880, viii. 432; Brit. Med. Jour., September, 1879, 634; *ibid.*, September 6, 1880; Lancet, 1879, iii. 654, 697, 727.

<sup>4</sup> Amer. Jour. Obstet., March, 1889, Nilsen; *ibid.*, xiv. 94.

The Wolffian duct and Müller's ducts, lying in their respective order along the external border of the Wolffian bodies, are also liable to deformation, especially the Müller's ducts, as from their proper fusion are formed the uterus and the vagina.

**Treatment.**—When the fistule is small, it is sometimes sufficient to cauterize its edges and then to stimulate healing by applications of tincture of iodine, while the urine is constantly drawn by a catheter. At other times the freshening of the edges of the opening and sealing with collodion and gauze are sufficient to effect a closure. The thermo-cautery may also be used as a freshening agent, but the knife is usually, as in all other fis-

FIG. 22.

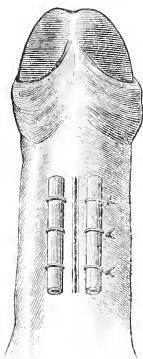

Fistule in the penile part of the urethra closed by quilled suture. (Agnew.)

FIG. 23.

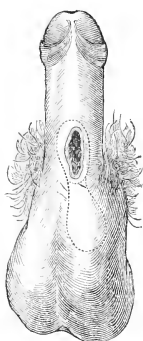

Urethroplasty. (Agnew.)

FIG. 24.

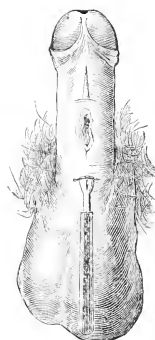

Nélaton's operation for closing urethral fistule. (Agnew.)

tules, the best of "caustics." Should these means fail, a plastic operation should be performed as in hypospadias by urethrorrhaphy or urethroplasty. (Figs. 22, 23, 24.)

#### SHORT FRENUM OR SHORT CORPUS SPONGIOSUM OR INCURVED PENIS.

This deformity rarely, if ever, exists without hypospadias, and it has already been considered on pp. 649. For its relief every retaining band should be divided, either by open incision or subcutaneously.

#### EPISPADIA.

Epispadia ( $\epsilon\pi\iota$ , "upon" or "above," and  $\sigma\pi\acute{\alpha}\zeta\omega$ , "I open") is the absence of the upper urethral wall throughout some portion of its extent, accompanied by a greater or less degree of separation of the corpora cavernosa.

**Etiology and Pathology.**—This vice of conformation is possible from

intra-uterine traumatism of governing cells, or from hereditary taint.<sup>1</sup> There follows an arrest of development, or a failure of union, or an uneven advancement in the evolution of the external and internal genital nodules. The existence of the urethra upon the dorsal portion of the penis is due to non-union and falling apart of the corpora cavernosa, which permit the advancement of the urethra during the tardy development of the internal genital nodules.

In the fifth or sixth week of intra-uterine life the cloaca or common cavity divides into the uro-genital portion in front and the anal in the rear. By the end of the second month the genital tubercle from which springs the penis, scrotum, etc., is formed. Should this genital tubercle be misdirected or misguided by the abnormal closing or bridging of the septum, the penis may be placed behind instead of in front of the uro-genital canal.

In other cases there may be an arrest of development, so that the two fasciculi destined to form the spongy portion of the urethra fail to unite, thus leaving the urethra open above. Should the superior external genital buds of Coste unite below instead of above in the corpora cavernosa, the groove will be superposed instead of subjacent. Should this unite as far forward as the glans, there will exist a dorsal tube; but if union fails to occur, then epispadia results. Unequal advancement of the internal and external nodules will give a similar result. The studies of Freund, K l-  
liker, and Kobalt are valuable in this subject.<sup>2</sup>

**Complications.**—Fissure of the pubes, exstrophy of the bladder, clubbed, distorted, and twisted penis, cryptorchidism, hernia, and other malformations frequently coexist.<sup>3</sup> Billroth saw two cases of double clitoris in which, with the epispadia, prolapsus vesic e existed.<sup>4</sup> This prolapse of bladder is common in males, and more or less incontinence of urine is always present.

The meatus is rarely found well forward upon the dorsum of the penis, but Anderson,<sup>5</sup> in twenty epispadic cases, male and female, found the urethral opening to be two and a half inches below the upper border of the symphysis. The prepuce is often irregular and redundant. The broad flattened penis applied against the abdominal wall sometimes acts as a valve and assists in retaining the urine<sup>6</sup> in the exstrophic bladder. (Fig. 25.)

In urination much annoyance is experienced by the scattering of the stream. In the female, fissure of the pubic bones is common, with a large opening directly into the bladder.<sup>7</sup>

<sup>1</sup> International Encyclop dia of Surgery, Ashhurst, 1887, vi. 497.

<sup>2</sup> Leutaigne, Trans. Royal Acad. Med. of Ireland, Dublin, 1888, vi. 306.

<sup>3</sup> London Medical Record, 1876, 562, Kuster.

<sup>4</sup> Medical News and Gazette, March 12, 1870, 278.

<sup>5</sup> Jour. Anat. and Physiol., London, 1880-1, xv. 378, 381.

<sup>6</sup> Amer. Jour. Obstet., ix. 288; Ber.  . d. Betrieb d. Ludwigs-Spit. Charlottenhilfe in Stuttgart, 1885-88, Chir. Abth., 86.

<sup>7</sup> St. Louis Courier of Medicine, 1886, 515.



When the deformity is multiple and the scrotum cleft, with a vesical hiatus and a reddened infundibulum, it is not strange that errors are made in the distinguishment of sex.

Sexual desire may be present, but cohabitation is difficult, and I know of no record of fertility in a complete epispadic male.

**Diagnosis.**—The question of sex may sometimes prove most embarrassing (see Exstrophy, Hermaphroditism, and Hypospadias), but must be determined by a most careful consideration of the predominating external and internal organs which are present.

**Prognosis.**—Thanks to advances in plastic surgery, not only may cases of uncomplicated epispadias hope to be to a certain extent relieved of their incontinence of urine, but, if a penis of moderate size be present, a channel may be constructed so as possibly to make the man a marriageable being. Even when a sphincter is not secured, the subsequent contraction following an operation and its resultant reflex action on the tube will assist in retaining the urine.

**Treatment.**—The treatment should not be delayed after the child reaches the age of four years, for reasons given on p. 633.

Plastic flaps must be secured from the most available site.<sup>1</sup> Nélaton, after the failures of Dieffenbach and Blandin, successfully united the sides of the fissure by freshening the edges of the depression and then reverting across it a long flap with integument inward, which flap was in turn covered by another, taken from the opposite side and placed with its denuded surface against the raw side of the first. When penile tissues are scanty, the scrotum or prepuce may be utilized for flaps, by passing the penis through a slit in the fold.

Thiersch very properly divided the operation into three stages, which division Duplay also adopts.<sup>2</sup>

1. *Straightening the Penis.*—This should be performed early in life, by multiple incision of all restraining bands, in order to facilitate development; but a redundant prepuce should not be sacrificed, as it may be needed for flaps. If a glans penis is present, however, the prepuce should be stripped from it at an early age.

FIG. 25.

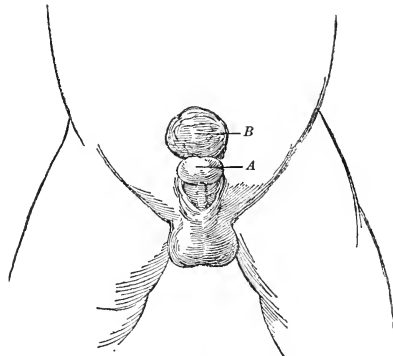

EXSTROPHY WITH EPISPADIA.—A, malformed penis; B, posterior vesical wall.

<sup>1</sup> Trans. Royal Acad. Med. of Ireland, Dublin, 1888, vi. 306.

<sup>2</sup> Ashhurst's International Encyclopædia of Surgery, 1886, vi. 496.

2. *Formation of New Canal.*—This may be accomplished by Nélaton's plan already mentioned, or by making on each side a wide free denudation

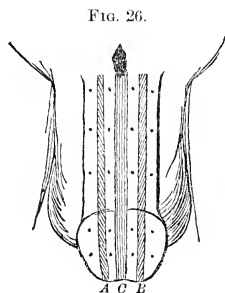

of a strip (*A* and *B*) external to the urethral gutter (*C*, Fig. 26), which two raw surfaces are brought together over a catheter, as in hypospadias (Fig. 21), and secured by single shotted wire quilled sutures passing through the tissues, as shown at the black dots (Fig. 26). These sutures should remain *in situ* for five or six days. The new urethra is really formed by approximation of the separated corpora. A catheter inserted through the abnormal opening will assist in keeping the wound clean, but frequent disinfection will be required, as in the operation for hypospadias.

3. *Closure of the Orifice.*—This is accomplished several weeks or months later, as described under Hypospadias.

If there is cleft of the pubes or exstrophy, the cure of the two conditions must be simultaneously considered. A number of operations may be necessary before success is attained.

It is well to defer until the end of treatment any purely cosmetic operation looking only to the improvement in form of the penis, as no tissue should be sacrificed until it is positive that it will not be needed for repair.

#### EXSTROPHY OR EXTROVERSION OF THE BLADDER, ECTOPION VESICÆ, OR HIATUS OF THE ABDOMINAL WALL.

Exstrophy of the bladder (ἔξ, "out," and στρουφύ, "a turning") is a condition characterized not only by an absence of the anterior wall of the viscus, but also by a deficiency of the abdominal parietes that permits a prolapse of the posterior vesical wall in the form of a reddened mass above the pubes.<sup>1</sup> Non-union of pubic bones, a dwarfed epispadic penis (Fig. 25), cleft scrotum, absence or non-descent of the testes, double inguinal hernia, and various other malformations, usually coexist.

In the female, in whom the deformity is found in the proportion of once in about seven or eight times as compared with the male,<sup>2</sup> a common cloaca may represent bladder, vagina, and rectum.

As uterus and ovaries may be present, however, parturition may take place, as instanced by Huxham and Thiebault.

In another instance the os uteri presented upon the surface beneath the ectopion, and impregnation would have been easy.<sup>3</sup>

When the dwarfed penis is lifted from its bed, the orifices of the ureters

<sup>1</sup> Journal of Anatomy and Physiology, 1881, xv. 226.

<sup>2</sup> Lancet, 1875, ii. 265.

<sup>3</sup> St. Louis Medical and Surgical Journal, 1879, xxxv. 286.

can be plainly seen, and in bad epispadic cases the prostatic sinuses, the ejaculatory ducts, and the veru montanum are disclosed.

The opening in the abdominal walls varies from half an inch to several inches in diameter, and the protruding vesical wall (*B*, Fig. 25) always becomes congested from the friction of clothing and apparatus.

The fissure in the pubic bones is sometimes so great that the diminutive penis (*A*) lies almost concealed in the sulcus. The alteration in the anatomy of the parts is well described by Doran.<sup>1</sup>

The lateral portions of the allantois, being diverted from their normal union or arrested in their anterior development, give rise to these strange varieties of malformation, and there is often produced an individual whose sex even is uncertain. As a rule, however, a short search will disclose the presence of distinctive sexual parts, as concealed testicles, spermatic cords, prostate gland, or uterus, etc.

In the male the deformity is usually so great that intromission becomes an impossibility, although sexual desire is often strong.

Practically shut out from respectable society on account of the horrid odor engendered by the decomposing urine that constantly dribbles from the opening, the child becomes morose and morbid, and drifts lower both physically and morally, until by the time that manhood is reached he becomes an object of loathing and disgust to himself and to others, both in his thoughts and in his actions.

**Diagnosis.**—The diagnosis of the exstrophy is easy, but the determination of the sex may at times be puzzling, except by a careful study of each individual organ present. (See p. 669.)

**Prognosis.**—A complete cure cannot be expected, but, if a good anterior protection to the bladder is secured, and the urine is directed into a pouch with a small orifice of exit, so that a proper urinal can be adapted, much will be gained both physically and mentally.

When skin-flaps are reverted in childhood, experience has proved that there will be no serious future difficulty from growth of hair within the bladder.

It should be remembered that nearly twenty per cent. of the cases operated upon die from peritonitis, pyæmia, or exhaustion from sloughing of the flaps,<sup>2</sup>—Coulson says twelve per cent.,<sup>3</sup>—but the benefits to be gained from a successful operation are sufficient to warrant the procedure.

**Treatment.**—*Mechanical.*—In infancy the softest of napkins should be employed, with pads of borated or salicylated cotton or gauze. The greatest care should be exercised to prevent excoriation, by the use of soda or borax water, cosmoline, powders, etc. During the activity of childhood it is almost impossible to apply any urinal with satisfaction, and the simple dressings should be continued until the operation is performed.

<sup>1</sup> Jour. Anat. and Physiol., 1881, xv. 226.

<sup>2</sup> International Encyclopædia of Surgery, Ashhurst, 1st ed., vi. 339.

<sup>3</sup> Coulson on the Bladder, Wood's Library, 1881.

In older life and subsequently to the operation, some modification of Earle's urinal made of rubber<sup>1</sup> or of metal,<sup>2</sup> so that the cup shall enclose the abnormal opening and conduct the urine into a tube leading to a receptacle strapped to the thigh, will best answer the purpose of cleanliness. (Figs. 27, 28, 29, 30.)

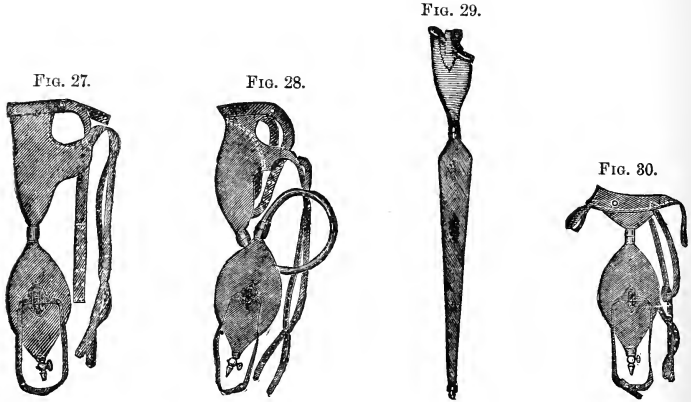

*Operation.*—Operative procedures<sup>3</sup> should be instituted early, for reasons already given on p. 633.

I. Conversion of the rectum into a urinary receptacle.

II. Plastic closure of the hiatus and collection of the urine at a small outlet.

I. *Diversion of the Urine.*—This plan was attempted by Simon<sup>4</sup> by establishing a communication between the ureters and the rectum by threads. The opening was secured, but the urine still flowed over the pubes, and the patient died in a year from kidney-disease.

Smith<sup>5</sup> turned one ureter into the colon and fourteen months later secured the other in the same position, but the child died on the third day after the second operation, from suppression of urine. The first kidney was entirely destroyed, and its ureteral opening into the colon was impervious.

Lloyd<sup>6</sup> and Johnston<sup>7</sup> both lost their patients by injury of the recto-vesical fold of peritoneum while passing the seton.

Holmes failed to maintain the opening which he had secured by clamp

<sup>1</sup> St. Louis Courier of Medicine, 1884, xii. 225.

<sup>2</sup> Ohio Med. Jour., 1880, i. 526.

<sup>3</sup> Pousson, Ann. d. Malad. d. Org. génito-urin., 1888, vi. 615; Mattvieff, Laitop. Khir. Obsh. v. Mosk., 1889, viii. 7, 22; Subbotin, Vrach, St. Petersburg.

<sup>4</sup> Lancet, 1852, ii.; Holmes, Surgical Diseases of Children, p. 147.

<sup>5</sup> St. Barth. Hosp. Rep., 1879, xv. 29.

<sup>6</sup> Surgical Treatment of Children's Diseases, p. 148.

<sup>7</sup> St. Barth. Hosp. Rep., 1879, xv. 29.

forceps through the vesical triangle. Sonnenberg<sup>1</sup> diverted the urine into the urethral groove upon the dorsum of the penis, and then extirpated the bladder; and Levis<sup>2</sup> established a perineal fistule while he closed the anterior abdominal fissure. His patient died on the twelfth day.

As all attempts to divert the course of the ureters or to introduce tubes into their calibres are not only attended with risk but are also followed by kidney-disease, and as the rectum, even in congenital opening of the ureters into it,<sup>3</sup> or in fistule, resents the presence of urine, the use of the bowel as a urinary receptacle seems to be decidedly contra-indicated.

Should the experiments of Fizzoni and Poggi, as practised upon dogs, for the *construction of a bladder* after removal of the viscus, prove sufficiently encouraging to permit its trial upon men, another chance of relief will be offered.<sup>4</sup>

II. *Plastic Closure of the Abdominal Opening.*—If the deficiency is small and the skin movable, as in young children, the edges may be freshened and covered with the raw face of flaps dissected back and drawn directly in from the lateral regions adjoining the opening. Longitudinal incisions made an inch externally, *A B*, will relieve the tension and facilitate union. The gaping cuts, *C*, will heal by granulation. (Fig. 31.)

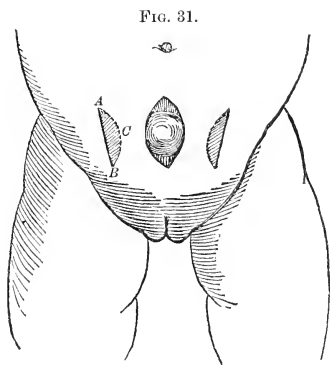

Closure of the hiatus has been successfully done on the third day of life; but infants so young as this bear the loss of blood badly.

Read<sup>5</sup> operated at six weeks on a female child in whom the protrusion of the bladder was through the umbilicus. He reduced the tumor through the hardened encircling ring, dissected up the skin about the opening, as I have myself done in patent urachus, and closed with fine horse-hair sutures, which were removed on the fourth day. Good union was secured, save at one point, where a drop of urine occasionally escaped.

Pancoast's operation, devised in 1858, secures flaps from the inguinal region, which are united in the median line with their epithelial faces inward, the raw surface being left to cicatrize. In Ayres's operation the exposed surface is covered with additional flaps.

Wood's reverting flap, *F*, is in the shape of an inverted U (see Fig. 32),

<sup>1</sup> Amer. Jour. Med. Sci., April, 1882, clxvi. 580; Centralbl. f. d. Med. Wissensch., January, 1882.

<sup>2</sup> Agnew's System of Surgery, 1st ed., ii. 613.

<sup>3</sup> Ibid., ii. 609.

<sup>4</sup> Lancet, April 27, 1889, p. 854; also Proc. Sixth Italian Surgical Congress.

<sup>5</sup> Annals of Anatomy and Surgery, Brooklyn, 1882, vol. v.

and is taken from the umbilical region above the opening. When turned down and folded upon itself at the line *A B* and sutured at the line *C D*, its raw surface is covered by two lateral flaps. This operation combines the advantages of Pancoast's and Ayres's. When possible, it is better to have the side-flaps large enough to cover in the raw surface and to enclose the base and dorsum of the penis, and also to construct a urethra, if possible, along the dorsum of the penis, as in epispadia. Sometimes the rudimentary penis can have a flap secured for it by thrusting it through an opening made in the serotal integument.

FIG. 32.

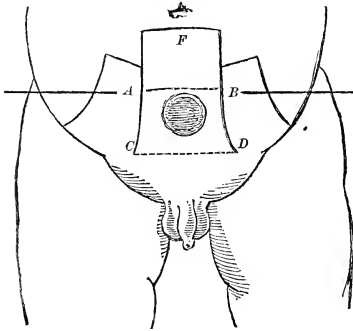

Roux and Maury secured a large convex flap of integument from the groin, perineum, and scrotum (Fig. 33, *D*), which, when turned up upon itself and folded at the line *A B*, was secured by tongue-and-groove sutures, after vivification of its

cutaneous border, in a groove cut in the abdominal integument above and around the hiatus. The penis was extended through a small slit cut in the flap. This leaves a large raw surface, *C*, but in its cicatrization the orifice of escape is narrowed, and the herniæ are sometimes benefited. The herniæ, however, can be more surely cured by returning them to the abdominal cavity and suturing the rings, as in Macewen's or McBurney's operation.

FIG. 33.

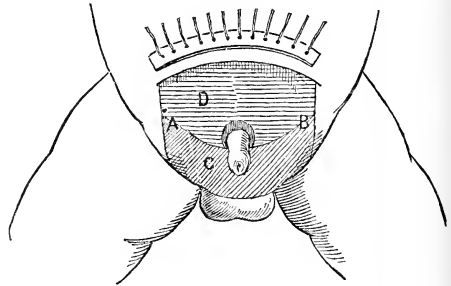

cutaneous border, in a groove cut in the abdominal integument above and around the hiatus. The penis was extended through a small slit cut in the flap. This leaves a large raw surface, *C*, but in its cicatrization the orifice of escape is narrowed, and the herniæ are sometimes benefited. The herniæ, however, can be more surely cured by returning them to the abdominal cavity and suturing the rings, as in Macewen's or McBurney's operation.

Bigelow denudes the posterior wall of the bladder as low as the ureters, in order to reduce the amount of mucous surface, which he accomplishes by applying upon this raw surface two inguinal flaps with raw tissue inward.

Hare-lip pins, twisted, tongue-and-groove, relaxation,<sup>1</sup> and interrupted-edge sutures<sup>2</sup> are the forms usually employed. Either catgut, silk, wire,

<sup>1</sup> *Lancet*, 1869, i. 255, and 1874, i. 198; *Med.-Chir. Trans.*, lii. 85, and liii. 187.

<sup>2</sup> *Liverpool Med.-Chir. Jour.*, January, 1882, and *Brit. Med. Jour.*, February 7 and 28, 1880; *Gaz. de Sanidad Méd.*, Madrid, 1879, 365.

or horse-hair may be employed. Perineal cystotomy assists in securing union.

Only when it is impossible to obtain flaps from any neighboring region is it justifiable to perform the Trendelenberg operation of dividing the sacro-iliac synchondrosis<sup>1</sup> and approximating the anterior superior iliac spines in order to relieve tension and give a larger mucous lining to the new bladder. When pubic fissure is present, it would be wiser to freshen the bones, forcibly bring them in apposition, and retain them by wiring.

The selection of tissue for the flap will depend upon the mobility of the surrounding skin.<sup>2</sup> In the female, as a rule, the abdominal integument will offer the best district, while in the male the redundant scrotal tissue may be utilized.

The epispadia can be still further closed by a later operation, and a more perfect valve be obtained for retention of the urine, even though the securing of a sphincter is impossible.

It is not to be expected that a cure will be effected without several attempts, and much care and patience will be necessary.

If the operation is performed with thorough antisepsis and weak sublimate dressings are applied, primary union will be best secured. A secondary removable dressing should be applied below, separated from the upper portion by sheet rubber. This can be renewed every few hours and the parts thoroughly cleansed after each urination by a sublimate solution, one to ten thousand. Rushton Parker kept the hips of his patient immersed in a warm boracic-acid bath during the process of healing.<sup>3</sup>

#### HERMAPHRODISM.

An hermaphrodite (*Ἑρμῆς*, "Mercury," and *Ἀφροδίτη*, "Venus") is an individual the deformation of whose genital organs either occasions an uncertainty in regard to sex, or gives the impression that certain of the organs of both sexes are present.

True hermaphrodisms—*vera lateralis*—with one half possessing the male germinal gland, or testicle, and the other half possessing the female ovary, is a condition which is rarely if ever present, and its existence must still be regarded as doubtful, in spite of the many apparent cases that have been reported.

Spurious hermaphrodisms in its various forms is not uncommon, and the general sexual conformation may be very puzzling at birth, when the presence of certain organs apparently belonging to opposite sexes is observed.

A male with cleft scrotum, undescended testicles, and a diminutive penis certainly bears a closer resemblance to a female than does a case of

<sup>1</sup> Med.-Chir. Trans., 1888, lxxi. 191.

<sup>2</sup> Brit. Med. Jour., 1880, pp. 202, 278, and 1885, p. 222; Phila. Med. Times, xii. 377; Amer. Jour. Med. Sci., July, 1871, cxxiii. 70; Glasgow Med. Jour., 1879, xi. 230.

<sup>3</sup> Liverpool Med.-Chir. Jour., January, 1882; St. Louis Med. and Surg. Jour., January, 1881; Ashhurst, International Encyclopædia of Surgery, 1st ed., vi. 538.

atresia vaginae with elongated clitoris, especially if the male penis is hypospadiac, with the urethral orifice opening in the perineum.

FIG. 34.

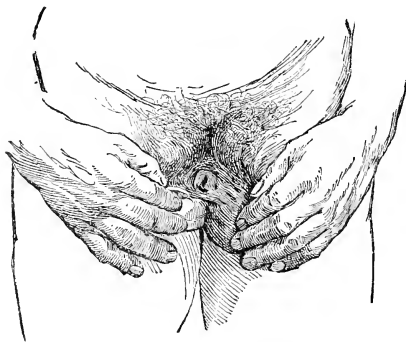

While the majority of so-called hermaphrodites undoubtedly are hypospadiac males, yet the absence of a visible penis is usually sufficient with the laity to cause the baptism of the infant as a female, and the true sex remains undiscovered until adult life is reached, when the descent of the testicles and the development of more masculine tendencies disclose the real character of the person.

Such was the case with the individual depicted in Figs. 34 and 35, who for twenty-five years lived as a female in the capacities of domestic, lady's waiting-maid, etc. During childhood the two folds of the entirely divided, non-testes-bearing scrotum doubtless bore close resemblance to the female labia, although now, at fifty-five, the weight of the late-descended testicles and the dragging upon these folds during micturition has made them quite pendulous. When I first saw him, fifteen years ago, no penis was discoverable at first sight, but upon separating the folds a small organ was found concealed

FIG. 35.

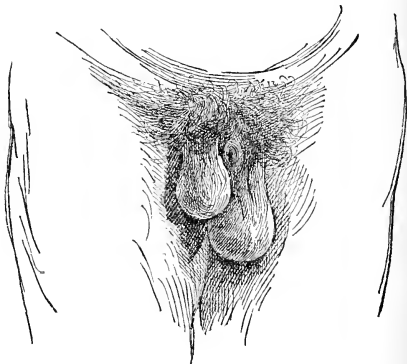

at the usual position of the clitoris. This penis was grooved upon the under surface of the glans and gave evidence of the existence of corpora cavernosa, but the spongiosum was absent and the urethral opening was beneath the arch of the pubes. This red-lined infundibulum would admit the little finger, and could easily have been dilated by continued copulation into a moderate-sized receptacle. His sexual desires were always, however, towards females, and, as the penis during erection became nearly an inch in length, he was not only able to procure an emission, but could also render a certain amount of pleasure to the woman, so that after donning male attire



he married. His beard appeared at forty, and at present writing, though insane, his figure and all his attributes are decidedly masculine.<sup>1</sup>

**Pathogenesis and Etiology.**—The study of the embryology of the two sexes shows the great similarity of the component parts and the ease with which errors of deformation may occur during the first two months of intra-uterine existence. Median union of the halves of the uro-genital sinus may be more or less interfered with, or the tubular prolongation anteriorly may be arrested by an altered condition of the external organs themselves, or, again, the primary female perineal fissure may unite and the clitoris undergo abnormal enlargement. (See Hypospadias and Epispadias.)

Heredity is a not infrequent cause.<sup>2</sup> Emmet<sup>3</sup> reports a brother and sister thus deformed. Phillips<sup>4</sup> and Pozze<sup>5</sup> record as high as four cases of spurious hermaphroditism in one family.

In the Museum of the Royal College of Surgery are specimens showing infant twins, each of whom possessed an exceedingly small canal leading up to a uterus and ovaries.<sup>6</sup> A sister was similarly deformed.

**Peculiarities of Formation.**—Tulpius,<sup>7</sup> De Graaf,<sup>8</sup> Paré,<sup>9</sup> and many other of the older writers describe cases reported to possess the two sets of organs, but they may easily have been deceived, as many of these individuals become for pecuniary reasons very adept in misrepresentation.

Errors in diagnosis are common even in this day, and the most astute diagnosticians have been arrayed upon opposite sides.<sup>10</sup>

The well-known case of Catharine or Carl Hohmann was examined by such able men as Recklinghausen, Friedreich, Virchow, Schultze, Mundé, and Rokitsansky, and is probably as nearly a case of true lateral hermaphroditism as any on record.<sup>11</sup> As a child she passed as an undoubted female. Developing at twelve years of age, at seventeen she showed strong sexual affinities for males, which she gratified for twenty years in a cleft, although she possessed no vagina. All her characteristics were feminine, and several physicians report that they actually saw menstrual blood exuding from the urethra. Menstruation is said to have occurred regularly for twenty years. Upon the right side was a well-formed testicle in a serotum; in the left inguinal region was a body, and to the left of and behind the small penis was

<sup>1</sup> For further description see Amer. Jour. Obstet., Willard, 1876, ix. 501.

<sup>2</sup> Brit. Med. Jour., February 23, 1889, 409; Med. Beobacht., Bd. ii. S. 234; De Fissuris Ureth. viril. congen., 34.

<sup>3</sup> Amer. Jour. Obstet., viii. 882, also 1886, xix. 1108.

<sup>4</sup> Trans. Obstet. Soc. Lond., 1886, xxviii. 158.

<sup>5</sup> Gaz. Méd. de Paris, 1885, ii. 109; Amer. Jour. Obstet., 1880, xiii. 174.

<sup>6</sup> Med. Times and Gaz., January 24, 1832, 84.

<sup>7</sup> Observat. Medicæ, cap. 65, 241, 1650.

<sup>8</sup> De Re Anatom., lib. xv.

<sup>9</sup> Œuvres d'Ambroise Paré, lib. xxv., cap. vi., Lyons ed., 1141.

<sup>10</sup> Dissert. sur les Hermaphrodites, 298, Arnaud, and Gerichtl. Med. Abhandlungen, Bd. i. S. 177.

<sup>11</sup> Amer. Jour. Obstet., viii. 615, Mundé; also Lancet, August 22, 1874, and Von Franqué, Scanzoni's Beiträge, v., 1867.

another mass, which two bodies were inferred by some physicians to be ovaries, but the question cannot be determined except by post-mortem in the future. In his female capacity the sexual orgasm gave a thrill upon the left side, according to *his* statement, which must be taken with "many large grains of salt." At forty, male characteristics appeared, and he subsequently married a woman, with whom, as his penis developed, he was able to produce the emission of a fluid containing spermatozooids.

Parsons<sup>1</sup> describes an individual with a prolapsed ovary in the right labium and a similar undescended organ in the left groin; yet these were more probably testicles, or they may have been similar to the masses found post mortem by O'Neill<sup>2</sup> to be a hardened congenital omental hernia on one side and a mass without glandular structure on the other.

Palmer<sup>3</sup> alludes to an autopsy by Meyers, where a withered testicle existed on the right side with penis and prostate gland, while on the left side was an ovary with Fallopian tube and uterus.

Even post-mortem examinations, when analyzed, are not as convincing of the dual nature as would seem from first glance. Stoneham,<sup>4</sup> for instance, reports the examination of a child who died from strangulated hernia. The external organs are said to have been of the male type, but, as there were no testicles, the supposed penis may have been simply a clitoris. A prostate gland enclosed the neck of the bladder, and behind this were a vagina and a uterus with cervix but without external os. On either side of the uterus lay organs that are denominated testes, but, as the physician fails to account for any ovaries, it seems much more probable that they were misplaced ovaries, especially as the Fallopian tubes were present. An epididymis is said to have existed.

The case certainly does not prove the existence of the two essential organs, testes and ovaries, and I have discovered no instance on record where dual procreative power has existed.

Hereditv is well instanced in the facts that two brothers of this case had penis and scrotum without testes, and that a sister possessed bifid nipples.

Burnet<sup>5</sup> also reports a post-mortem in which testicle, ovary, prostate gland, and uterus were present; but Woodward thinks that the ovary was only a mass of adipose tissue, and that the so-called uterus and vagina represented the united vesiculae seminales, the conformation of which was irregular in consequence of the arrest of development due to non-descent of the testes. Huffner<sup>6</sup> also reports a child dying at ten months in whom both testicles and ovaries were present.

<sup>1</sup> Mechanical and Critical Inquiry into Hermaphroditism, p. 144.

<sup>2</sup> Amer. Jour. Med. Sci., 1851, xxii. 558.

<sup>3</sup> Amer. Jour. Obstet., 1880, xliii. 174; Med. Gazette, xix. 139; Cincinnati Lancet and Clinic, 1879, iii. 435.

<sup>4</sup> Lancet, 1888, i. 371.

<sup>5</sup> Amer. Jour. Med. Sci., xxvi. 367.

<sup>6</sup> Centralbl. f. d. Med. Wissensch., January 3, 1871.

Willecocks<sup>1</sup> gives the results of a post-mortem upon a *supposed* female child, in whom testicles and vas deferens were present but no female organs existed.

The constantly-found condition of a prostate gland in males is not a positive diagnostic sign, since, in a case where a mass of dense fibrous tissue existed at the neck of the bladder, a committee of the Pathological Society of London decided that it was not a prostate, since neither sinus peculiaris nor veru montanum nor ducts were present.

Barnes records a post-mortem upon the body of a child who died at three weeks, in whom a hypospadiac opening had existed at the frænum of what appeared to be a penis but was really a clitoris. There were neither uterus nor ovaries present.

In Tidy's "Legal Medicine," Mann's "American System of Gynæcology," the *New England Medical Monthly*, 1883-84, p. 342, and 1884-85, p. 1, Simpson's "Anæsthesia, Hermaphroditism," etc., 1871, Edinburgh, and the "Dictionnaire des Sciences Médicales" (article Hermaphroditism), will be found the records of cases that have puzzled the most astute anatomists.

Fowler<sup>2</sup> exhibited to the New York Obstetrical Society, for Drs. Avery and Sayre, the cast of the pelvic organs of a supposed male who was reported to have menstruated through his penis. Fig. 36 is from this cast,

FIG. 36.

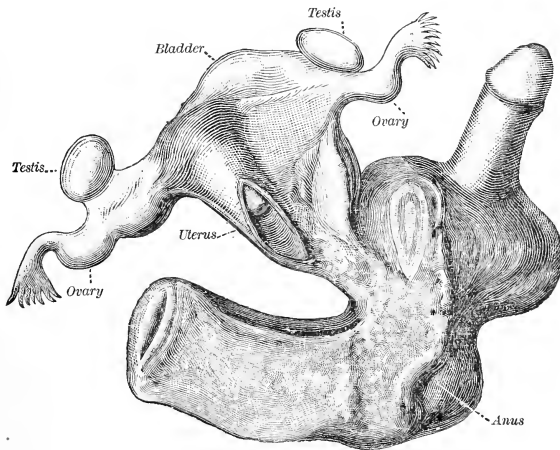

and shows the organs undoubtedly of a female with probably a large clitoris. It is also definitely stated that the person possessed feminine characteristics. Being interested in arriving at the possibility of the exist-

<sup>1</sup> Trans. Path. Soc. Lond., 1884, xxxvi, 309.

<sup>2</sup> Amer. Jour. Obstet., 1887, 423.

ence of the two masses labelled "testicles" and "ovaries," I wrote to Dr. Fowler to learn whether these had been proved to be such organs.

His reply was as follows :

I found a wax model of the alleged hermaphroditic organs among some old rubbish, traced the case to Dr. Sayre (to whom it had been sent by Dr. Avery), and learned all that has been stated in the *American Journal of Obstetrics*. Sayre had the model made from the specimen sent him in alcohol, and declared that the organs which I have labelled ovaries and testes are such. Of course I asked whether a microscopic examination was made, and the reply was that it was not, because very few had such an instrument in those remote days. So you see this case, as remarkable as it appears to be, falls in with the rest of its kind. Yet, were you to see the cast, I am sure you would be "almost persuaded."

Very truly yours,

GEO. B. FOWLER.

There is, therefore, no positive proof that the masses labelled "testes" are other than adventitious ovaries, or simple non-glandular masses, or malformed portions of a Wolffian body. The duality of sex is in this case, as in nearly all others, certainly not proved, and is more apparent than real.

In Taylor's "Medical Jurisprudence" is also quoted a case with testicle, epididymis, and spermatic cord in the left labium, and a supposed ovary, together with rudiments of a uterus, in the right.

Many of the foregoing cases are instances of hermaphroditism by excess of either male or female organs, or are examples of imperfect bisexual organizations. A few are instances of superposed or crossed hermaphroditism. While these hermaphrodites have frequently become mothers or fathers, there is no instance on record where they have occupied both relations,—*i.e.*, father and mother. Should such a result ever be claimed, it would certainly be open to the widest suspicion of exaggeration and fraud, to which so many of these "professionals" are addicted. It would be very easy for a hermaphroditic mother with enlarged clitoris, who had married a woman subsequently to the birth of her own child, to invite outside male assistance in the impregnation of her wife, and then claim that she was a father; or, even if honest, such "assistance" might be rendered without her knowledge.

Simpson<sup>1</sup> reports the case of a pseudo-female who applied for permission to marry a real woman pregnant by him. Although a husband is reported by Bankin to have borne a child,<sup>2</sup> yet she was undoubtedly a female, and acknowledged to having cohabited with a male.

A hypospadiac male with a penis an inch in length, but with an infundibulum two inches in depth between the testes-bearing halves of a cleft scrotum, was found in blissful wifely contentment after twenty years of wedded life with a husband.<sup>3</sup>

<sup>1</sup> Todd's Cyclopædia of Anatomy and Physiology, art. Hermaphroditism; Lond. Med. Rev., iii. 525; Dict. des Sci. Méd., 95.

<sup>2</sup> Lit. de Hermaphrod., cap. 23, 1609.

<sup>3</sup> Canada Lancet, Toronto, 1883-84, xvi. 134.

The Greeks called these unfortunate beings Tribades, and statues representing various forms of hermaphrodites have been unearthed at Pompeii and Herculaneum.<sup>1</sup>

A spurious hermaphrodite is reported who was considered to have had *two bladders*, a penis connecting with one, while the other was reached by a urethra; but one of them may have been only a *cul-de-sac*.<sup>2</sup>

For further literature upon the subject the reader is referred to Fisher's "Teratology," to the *American Journal of Obstetrics*, xiv. 94, to the *Journal of the American Medical Association*, October 20, 1888, to the *Journal of Anatomy and Physiology*, London, 1883, xvii. 86, etc.

**Diagnosis.**—The diagnosis of sex in early childhood is important for reasons already expressed. A careful examination should be instituted, and the sex declared in conformity with the preponderance of existing sexual organs. We are now too far advanced in our means of diagnosis to be guided by Aristotle's rule that "it is to be considered in which member it is fittest for the act of copulation;" but both external and internal organs should be most conscientiously investigated.<sup>3</sup>

An enlarged clitoris<sup>4</sup> is not unfrequently present at birth, and should it continue to grow it may reach even to twelve inches in length.

Cases of superposed or semi-lateral or crossed hermaphroditism are often very puzzling, but care will assist in the formation of a correct opinion.

The absent testicles and the diminutive penis certainly tend to mislead, but I have found the majority of these cases to be varieties of males, which experience, however, differs from that of Parmley,<sup>5</sup> who considers the majority to be females with elongated clitoris. In olden times all these latter cases were classed with hermaphrodites, although they were undoubted females. In the same category also have been classed women who simply had prolapsus uteri<sup>6</sup> or vulvar tumors. The perverted sexualism of these females may induce them to become lovers of women, and to practise Sapphism at an early age. By reason of the pain and inconvenience experienced during coition with men, they may also assume the position of a man, and thus receive and give a certain amount of pleasurable feeling with a woman.

Thus it will be seen that even in later life the direction of sexual desire, while it is of assistance in forming a correct diagnosis, yet is not infallible.

Sexual impulse is mainly dependent upon the presence of testicles or

<sup>1</sup> Amer. Jour. Obstet., 1886, xix. 931; Lancet, March 9, 1889, p. 481.

<sup>2</sup> Amer. Jour. Obstet., ix. 171; Cincinnati Lancet and Observer.

<sup>3</sup> St. Thomas's Hospital Reports, ix. 29, 35; Boston Med. and Surg. Jour., 1883, cxviii. 195.

<sup>4</sup> Haller, Elem. Physiol., 1671, vii. 81; Hermaphroditism, Cyclop. Anat. and Physiol., 1839; Trans. Obstet. Soc. Lond., 1882, xxiv. 188, 239, 240, and 1886, xxxviii. 158; Trans. Path. Soc. Lond., xxiii. 169, and xi. 158.

<sup>5</sup> Amer. Jour. Obstet., 1886, xix. 931; Riolanus, Encheiridium Anatomicum et Pathologicum, 1658.

<sup>6</sup> Detroit Clinic, i., No. 18, 141.

ovaries, but the feeling may be entirely absent, and in this neutral state circumstances may alter affinities. Again, it may be abnormally increased, and may develop as early as four years,<sup>1</sup> and at puberty may lead to excessive degradation.

The absence of proper genital functions may alter the voice and form, the growth of hair, and the characteristics of the individual,<sup>2</sup> but, as these conditions are to be taken in connection only with the study of both external and internal genitalia, they will seldom mislead.

The cases of large clitoris associated with absent vagina or absent uterus, or with uterus emptying into the bladder,<sup>3</sup> are, of course, females minus certain organs; yet in early childhood absolute certainty is impossible.

Cameron<sup>4</sup> mentions a supposed girl who menstruated at thirteen and occasionally for several years later. She married at seventeen, but soon developed masculine tendencies and sought for females. She possessed no uterus, the vagina was but a cul-de-sac, and there were two testicles in the supposed labia.

On the other hand, an *apparent* male may possess a uterus.<sup>5</sup>

Menstruation, if regular and unfeigned, is, of course, presumptive evidence of the existence of an ovary; but such flow may be absent even in an undoubted female, or it may escape through the bladder.<sup>6</sup>

Even where both vagina and uterus were absent, the mons has been found covered with hair at four, the mammæ well developed at ten, and at sixteen the features still girlish.<sup>7</sup>

When cryptorchidism<sup>8</sup> is present with cleft scrotum, as is so common at birth, a careful search must be instituted for the missing testicles. Pro-lapse of ovaries, even into the inguinal canal, is very rare.

The exceedingly diminutive character of the organs in the new-born renders examination difficult, but with probe and sound distinctive portions even of internal organs can usually be discovered.

If ether is used, great care must be exercised, as the delicate tissues of infancy and childhood are but slightly resistant to the efforts of a strong man. This fact cannot be too strongly fixed in the minds of all surgeons, as many accidents have occurred.

The prostate gland is rarely absent in males, but must not be mistaken for a uterus.

<sup>1</sup> Brit. Med. Gaz., April 13, 1872; Med.-Chir. Trans., i. 276, 285; Amer. Jour. Med. Sci., October, 1852, 561; Brit. Med. Jour., April 27, 1872, 461.

<sup>2</sup> New York Med. Jour., 1882, and Obstet. Rev., 1882. xxxv. 23.

<sup>3</sup> Phila. Med. and Surg. Reporter, 1884, li. 516.

<sup>4</sup> Glasgow Med. Jour., 1885, xxiii. 213; Med. Press and Circular, 1888, xlv. 459.

<sup>5</sup> Phila. Med. and Surg. Reporter, 1883, 47; New York Med. Jour., July 10, 1886.

<sup>6</sup> Med. Times and Gazette, February 18, 1860, 170, and June 22, 1872; Amer. Jour. Med. Sci., 1872, 512, also July, 1847, also vol. xxvi. p. 65; Virchow's Archiv f. Gyn., March, 1869.

<sup>7</sup> Med. Times and Gazette, February 21, 1852, 187, also 1873, 691.

<sup>8</sup> Edin. Med. Jour., xliii. 123, 313.

When the sex is uncertain, it would be wise to pronounce the infant a probable male and await developments, since less inconvenience would arise from an error in this direction.

**Treatment.**—Plastic surgery will sometimes be of service by relieving hypospadias or epispadias or exstrophy, or by unloosing a webbed penis or liberating the organ when concealed, or by removing an elongated clitoris. No rules can be laid down, save that every possible attempt should be made in childhood to instruct these individuals as to their proper sex and to restore the parts as nearly as possible to their normal condition, thus saving them great mental distress and degradation.

The proper time for operation will be between three and six years of age, for reasons given in the discussion on p. 633.

Before removal of an apparently enlarged clitoris the diagnosis of sex should be positive, lest the organ be a male penis.

When the absence of essential organs or the malformation is so great as to preclude the possibility of child-bearing, it is good surgery to unsex the patient at an early age, as discussed on p. 634. The effect, both physically and psychically, will be beneficial. Gross<sup>1</sup> removed the testicles from the cleft scrotal pouches in one case. The child is reported to have had girlish proclivities.

#### DOUBLE OR SUPERNUMERARY BLADDER.

The condition of double bladder is a very rare one, some even of the reported cases bearing evidence that the second canal leading up to a viscus may have been but an opening into a cul-de-sac.<sup>2</sup> Occasionally, however, the urethrae from two separate male organs<sup>3</sup> enter separate compartments, and in one instance lithotripsy was successfully performed in one bladder while the other was healthy.

It is not probable that any treatment will be necessary for such a condition. The only formation likely to give trouble would be in a two-cavity bladder, where the septum existed only throughout a portion of the viscus. In such a case supra-pubic incision would permit examination and possibly partial removal.

#### ABSENCE OF BLADDER.

In rare instances the bladder may be entirely absent, in which case the ureters will be found emptying into the rectum or vagina, into the urethra directly, or at the umbilicus. A certain amount of contractility is usually present at the outlet, and the ureters sometimes become so pouched and dilated that they are capable of retaining nearly an hour's excretion. Usually, however, the dribbling of urine is constant, as in Winter's case,<sup>4</sup>

<sup>1</sup> Amer. Jour. Med. Sci., October, 1852.

<sup>2</sup> Amer. Jour. Obstet., ix. 171; Cincinnati Lancet and Observer, 1871.

<sup>3</sup> Smith, Trans. Med. and Chir. Faculty of the State of Maryland.

<sup>4</sup> Amer. Jour. Obstet., April, 1889, 374.

where the ureters had their exit just inside the imperfect labia of a female child. In Oliver's case the patient reached adult life.<sup>1</sup>

**Treatment.**—As in exstrophy, partial comfort may be secured by the use of a urinal attached to the body. (See Fig. 27.)

Operative measures have thus far failed to give relief, as the rectum has resented all attempts to convert it into a receptacle for urine.

Should, however, the experiments of Fizzoni and Poggi,<sup>2</sup> as now practised upon dogs, result in the possibility of securing in human beings a like construction of a bladder, there may yet be some hope for these unfortunates.

The application of a truss-pad at the orifice, when feasible, might dilate the ureter into a receptacle, but such a course would probably result in kidney-disease.

#### OPEN OR PATENT URACHUS.

Open urachus is a condition that is rarely present: individually I have observed but two cases.

The explanation of the fistule is easy. The extra-abdominal and intra-abdominal portions of the allantois in early fetal life communicate through the umbilicus. When the shrinkage and disappearance of the former occur, and the lower portion of the latter resolves itself into the urinary bladder, there still remains the upper portion of the latter, which in the normal progress of development shrinks and becomes converted during the eighth month into the fibrous cord extending from the top of the bladder to the umbilicus. Failure of closure occasionally occurs, and there then results a small canal that will permit a greater or less escape of urine through its outlet at the umbilicus.

In one of the cases alluded to, this had existed for three years from birth, and the surrounding parts had been kept in a moist, irritated, and eczematous condition from the continuous escape of a few drops of urine.

A careful search will usually disclose the fact that there has been some interference with the free escape of urine, thus giving backward pressure upon the urachal canal and tending to keep it patent.

In one of my cases the labia minora were firmly adherent. A tightly-contracted prepuce might produce the same result, as would also an impacted calculus.

**Treatment.**—In the case upon which I operated, thorough cauterization of the edges of the fistule had been unsuccessfully tried. I pared the edges extensively and brought the deep parts together with catgut sutures. The wound healed promptly under antiseptic dressings, but in a few weeks reopened, though the flow of urine was greatly lessened. Finding a deep pouch inside of the umbilical ring, I scraped it out thoroughly, cauterized its whole surface with chloride of zinc, pared the edges of the ring, and

<sup>1</sup> Lancet, December 6, 1879.

<sup>2</sup> Lancet, April 27, 1889, p. 854; also Proc. Sixth Italian Surgical Congress.



inserted a drainage-tube to the bottom. This was slowly withdrawn as the granulating process went on, and a perfectly solid closure was secured, which has now been tested for two or three years. A probe could not be carried into the bladder from the urachus, but the issuing fluid was distinctly urinous. There was no obstruction to the exit per urethram save the adhesion of labia before mentioned.

Should there be any impediment to the free escape of urine, it should of course be removed before attempting to close the fistule. I did not use the catheter in my case, but instructed the child to urinate every hour for the first week, so as to permit no accumulation.

Bramann reports two cases that had gone on to adult life.<sup>1</sup>

Cysts of the urachus are not uncommon. They are most frequently seen by laparotomists.<sup>2</sup>

---

<sup>1</sup> *Archiv f. Clin. Chirurg.*, Berlin, 1887, xxxvi. 996.

<sup>2</sup> *Lancet*, October 6, 1888, 674.

# DISEASES OF THE BLADDER.

By A. VANDER VEER, M.D.

---

## RETENTION OF URINE.

RETENTION of urine in children is by no means a common affection. Obviously the chief causes, obstructive lesions, are rarely incident to childhood.

**Causes.**—Retention of urine can hardly be dignified by the term disease, but is rather a symptom arising from a great variety of causes, among which the chief are nervous, traumatic, congenital, obstructive.

The nervous causes, which cover the greater portion of cases, are either reflex or cerebro-spinal. The cause is reflex in fissure of the anus, rectal polypus, ascarides, hemorrhoids (rarely), phimosis, the action of cantharides, turpentine, and similar remedies, and the free use of anodynes. It is cerebro-spinal in meningitis, hysteria, cerebral tumor, dentition, and Friedreich's ataxia.

Traumatic causes usually arise from blows to the perineum or hypogastrium, fracture of the pelvis, or concussion of the spine.

Congenital defects, such as phimosis, stricture, agglutination of the labia minora, membranous occlusion of the urethra, have been reported in isolated cases as causes.

Obstructive causes are due to stone or tumor acting mechanically.

**Pathology.**—The pathological conditions lying back of retention from nervous causes are most interesting. In consequence of the intimate connection between the nervous mechanism of the rectum and the bladder, irritation of the sensory nerve-ending of the rectum gives rise through the automatic centre of the cord to irritable bladder or retention of urine. The peripheral irritation from phimosis acts similarly. The administration of cantharides, turpentine, and similar remedies, by an irritation of the sensory nerves reflexly, keeps the sphincter vesicæ tetanically contracted. In certain diseases irritation of the inhibitory conducting paths or of the cortical centres is capable of producing at one time irritability and at another time retention. Such, doubtless, is the case in hysteria, meningitis, and rarely in Friedreich's ataxia.

**Symptoms.**—The history of the case, the presence of a globular tumor

above the symphysis pubis, and the increased tension of the recti muscles, together with dullness upon percussion and possible fluctuation, all go to make a clinical picture not likely to be mistaken.

**Diagnosis.**—It is barely possible to mistake suppression for retention of urine; the absence of the globular tumor, of the increased tension, dullness, and fluctuation, together with the fever and dry skin, will usually dispel any doubt. However, catheterization makes the diagnosis absolute.

**Prognosis.**—The prognosis of retention of urine in children is good. Most neurotic affections are but temporary. In organic nervous diseases the prognosis will depend upon the cause. Congenital defects will call for the intervention of surgery. Traumatism is seldom permanent.

**Treatment.**—A careful study of the case should be made to determine the cause, which in some cases will call for all our diagnostic resources. Treatment is immediate and curative. The first indication is to evacuate the bladder. It is not always wise to resort to the catheter at once. It is difficult to secure the necessary co-operation of children in the use of instruments. Catheterization is not unattended with danger. Rupture of the bladder has occurred from the struggling of the patient, and cystitis may be lighted up even by the most careful. Again, the operation is not regarded as particularly humane by the fond mothers. However, catheterization should be resorted to before damage may be done,—chloroform being administered when necessary.

In purely reflex cases a hot bath followed by full doses of bromide of potash or moderate doses of Dover's powder will usually be effective. In hysteria catheterization should be avoided as long as possible. Faradization of the bladder or the introduction into the rectum of nicely-moulded suppositories of ice every two hours will rarely fail.

Curative treatment will demand the treatment of rectal disorders, the removal of redundant and adherent prepuces, the separation of adherent labia, the division of occluding urethral membranes, and the relief of stricture.

Rupture of the urethra followed by retention and extravasation from perineal injuries should be treated by an immediate external urethrotomy.

Systemic diseases will always call for treatment proper for each disease. Stone and tumors always call for operation.

#### IRRITABILITY OF THE BLADDER.

**Causes.**—Irritability of the bladder may be dependent upon—1, diseases of the genito-urinary system; 2, diseases of neighboring organs; 3, disorders of the general system.

Many of the genito-urinary diseases, such as vesical tumor, stone, cystitis, renal calculus, neuralgia, and hyperæsthesia of the neck, are invariably accompanied by vesical irritability. Disorders of the urinary excretion—that is, very acid or very alkaline urine—are causes in rare cases.

Diseases of the rectum and anus, fissure of the anus, polypus, hemor-

roids, an overloaded rectum, ascariides, are frequently causes in children. Adherent prepuce reflexly is a cause of irritability of the bladder.

Dentition, gastric disorders, diseases of the nervous system, and, above all, the uric-acid diathesis, are causes. Prof. E. L. Keyes has given interesting histories of cases of chorea where the bladder was severely affected.

The pathology in some cases is very similar to that of cases of nervous retention, and in others it will depend upon the cause.

The symptoms are frequent urination, tenesmus, and pain, the pain being referred to the perineum, the hypogastrium, or the glans penis,—one or all of these regions.

**Diagnosis.**—Irritability of the bladder cannot be mistaken for anything else. The only necessary point is to inquire carefully into the cause. In any case where the symptom persists, the bladder should be carefully examined for stone or tumor, and the rectum explored.

**Prognosis.**—In most cases the prognosis is good, the causes being very amenable to treatment. Cases of neuralgia often run a protracted course. The irritable bladder of Friedreich's ataxia, a rare disease in children, is not greatly benefited by treatment. In hysteria the condition may be refractory, yet it seldom persists.

**Treatment.**—All treatment should be directed to the cause. Stone, tumor, and phimosis require surgical interference. Cystitis calls for appropriate treatment. Neuralgia will require the use of tonics, electricity, and anodynes, although treatment is likely to be tedious. Hyperæsthesia of the neck will be best treated by counter-irritation by small blisters to the perineum, making the urine bland by the administration of diluents. A small glass of Vichy night and morning and a bland diet are useful adjuvants. The use of hyoseyamus, or of belladonna or its alkaloid atropia, either by the mouth or by the rectum, is sometimes successful. In obstinate cases the instillation of three to five minims of a solution of nitrate of silver (gr. x to ʒi) into the deep urethra succeeds admirably. It should be repeated every week. Cocaine may be used for local anæsthesia. Disorders of the urinary secretion should be corrected. Alkalinity should be combated with the mineral acids and bitter tonics. Benzoate of sodium is valuable in these cases.

In children who have inherited the uric-acid diathesis there is at times irritability of the bladder from a very acid urine. This condition is best combated by the use of colchicum, either the wine or the acetous extract, by the preparations of lithia, or by the alkaline mineral waters.

#### CYSTITIS.

None of the coats of the bladder are free from the danger of inflammatory changes. The mucous, muscular, and peritoneal coats may be separately or jointly affected. Vesical catarrh or inflammation of the mucous coat is most common in childhood. The disease may be either acute or chronic.

**Causes.**—Keyes has made a very useful classification of the causes of cystitis,—viz., 1, traumatism, mechanical or chemical; 2, extension of inflammation; 3, exacerbation of pre-existing inflammation; 4, specific action of drugs; 5, neurosis; to which I add—6, general or systemic infection.

1. Fracture of the pelvis, blows upon the hypogastrium, retention of urine, unskilful use of the catheter, the irritation of stone or tumor, all mechanically cause cystitis. An altered urine, very acid and scanty, or decomposing from bacterial infection, may cause cystitis. The use of irritant injections may be a cause.

2. At autopsies on children Henoch has found stone impacted in the pelvis of the kidney, attended with considerable pyelitis. By extension of the inflammatory process the bladder may become affected.

3. In connection with stone, tumor, and abnormal urinary excretion, there is very frequently a variable amount of chronic cystitis. Exposure to cold or errors of diet may in such cases give rise to an active inflammation.

4. The free use of cantharides, of terebinthines, of cubeb, or of the balsams is capable of producing cystitis by direct irritation.

5. Paralysis from spinal curvature, chorea, or reflex irritation from the kidney, rectum, or prepuce may cause cystitis.

6. Cystitis occurs in the course of certain infectious and contagious diseases, typhoid fever, typhus fever, scarlatina, and diphtheria. I feel sure that I have seen it arise from malarial infection.

**Pathology.**—At the onset of an acute cystitis the mucous membrane of the bladder is hyperæmic, swollen, and secreting a serous fluid. The hyperæmia is likely to be most marked about the neck; ecchymotic spots will be observed, and in the severer cases purplish patches may be found. The mucous glands located in greatest numbers about the trigone are distended with a pearly secretion and surrounded by a dark-red areola. The superficial epithelium exfoliates, leaving erosions. The secretion becomes muco-purulent. The mucous membrane may become gangrenous. Abscess of the muscular coat takes place occasionally in severe cases. There is always more or less ulceration about the neck of the bladder.

There is a class of cases in which the exudation is diphtheritic; coats of the bladder have been expelled by the female. The urine is at first acid, and contains but few pus- or blood-corpuscles, but shows a slight increase of mucus. Later the reaction becomes alkaline, and a greater amount of muco-purulent sediment is found, mixed with blood and epithelial cells.

**Symptoms.**—The symptoms of acute and those of chronic cystitis differ only in degree. In an acute case the patient's attention is first called to the disease by an uneasy feeling in the pelvis and by frequent micturition. These two symptoms rapidly grow worse: uneasiness gives place to severe pain in the perineum, hypogastrium, back, or thigh: the pain may be located in the glans penis. Micturition becomes more frequent. The presence of urine in the bladder is intolerable, and the secretion is expelled in drops, which may be filled with blood. In children rigors and convul-

sions are common. From loss of sleep and pain the face has an expression of anxiety; the features are drawn; the depression is very great. If the case does not improve under treatment, rigors recur with greater frequency; the temperature is exacerbated; the skin is covered with clammy perspiration of a uriferous odor, and jactitations, delirium, and coma supervene, soon to be followed by death.

Happily, few cases are so severe in their symptoms. Cystitis may be of any degree of severity. Chronic cystitis may give very little discomfort; micturition not frequent; pain altogether bearable, except during periods of exacerbations due to cold, excessive exercise, or dietetic indiscretions. Examination of the urine will always give indications of the condition of the bladder.

**Diagnosis.**—A careful study of the symptoms and an examination of the urine will not allow of a mistake in the diagnosis of acute cystitis. Pyelitis may be mistaken for chronic cystitis, and in many cases the differential diagnosis will be impossible. In pyelitis or pyo-nephrosis the urine is acid and contains pus and epithelium. Especial stress is placed upon the presence of "tailed" epithelium in the urine. Although the bladder may be irritable in pyelitis, the irritability is not likely to be commensurate with the amount of pus in the urine. The pain of pyelitis is likely to be more confined to the lumbar region: there may be localized tenderness and swelling. Bimanual palpation of the bladder will fail to determine undue tenderness. When cystitis is complicated with pyelitis, the diagnosis will be only probable. In childhood chronic cystitis is an indication for exploration of the bladder with a searcher unless another evident cause exists. In this manner diagnosis of stone and often of tumor will be easily made.

**Prognosis.**—The prognosis in cystitis will be that of the cause. Many of the causes are very amenable to treatment. The greater proportion of cases get well in from ten days to two weeks. In cases where there is a diphtheritic exudation the prognosis is bad. Chronic cystitis arising from spinal caries can be only palliated. The treatment of cases of chronic cystitis is, at the best, tedious, and there is liability to relapse.

**Treatment.**—The primary indications in the treatment of acute cystitis are rest in bed, relief of pain, and administration of diluents. A hot bath should be given at the onset, and repeated daily if possible. The bowels should be kept open by the administration of mild aperients (avoiding aloes) or warm-water enemas. Careful attention should be paid to the diet, only plain food, preferably fluid, being allowed. Acids, stimulants, and fruits should be prohibited; meats must be given very sparingly; melons may be allowed *ad libitum*. Quinine and iron should be administered in tonic doses. The tincture of chloride of iron in ten-minim doses is the most eligible preparation. Quinine may be given in pill form, two grains every four hours. Hot anodyne poultices should be applied to the hypogastrium. The patient should be kept in bed, with the hips elevated by means of an air cushion or a hard pillow. Opium in combination with belladonna

should be given, preferably by suppository, in sufficient quantity to relieve pain and procure sleep. The citrate of potassium should be given dissolved in a glass of Vichy water every four hours. The old prescription of liquor potasse and hyoseyamus may be substituted. Flaxseed or slippery-elm tea or an infusion of triticum repens may be given for a drink.

In chronic cystitis all the means already recommended will be useful as adjuvants in the treatment. Fluid extract of corn-silk in combination with benzoate of sodium enjoys considerable reputation as a remedy. The fluid extract of pichi in my hands has been worthless. Counter-irritation by means of blisters or by the point of the Paquelin cautery applied to the hypogastrium should not be lost sight of: it often does good.

Finally, the bladder may be washed out with warm borax-water, a solution of benzoate of sodium (5i to Oi), or an infusion of golden-seal. In cases where there is a great amount of purulent secretion a solution of acetate of lead or chlorate of potassium may be employed in the irrigation with good results.

#### TUMORS OF THE BLADDER.

Primary new growth of the bladder is especially rare before puberty. After a somewhat extended examination of the literature of vesical new growths, I have been able to collect the histories of twenty-two cases occurring in childhood.

The etiological factors in tumors of the bladder are not more clearly defined than those of tumors situated in other parts of the body. Cohnheim's hypothesis of embryonic remains is worthy of some credence.

**Pathology and Morbid Anatomy.**—Tumors of the bladder as they occur in children may be thus classified: 1, villous growths; 2, mucous growths; 3, fibrous growths; 4, malignant growths; 5, mixed growths.

Of the twenty-two cases the histories of which form the basis of this article, eleven were mucous, five were malignant, four were villous, and two were mixed growths.

The mucous growths are similar in every respect to soft nasal polypi, and are especially incident to childhood. Winchel found two in the bladder of a child that died a few hours after birth. They may be single or multiple, and are usually pedunculated.

Sir Henry Thompson once said, "Pure fibrous growth in the bladder is a very rare occurrence, known to me only in museums." There is no case known of pure fibroma in children.

There are on record four cases of villous growths in children, including the case where Mr. Bryant removed a small papilloma by its being caught in the eye of a catheter. They do not differ structurally from papilloma found elsewhere. They are not malignant.

Of the malignant tumors of the bladder the case of medullary cancer occurring in a child four years old, reported by Smythe, stands alone as the only instance of primary malignant growth in childhood confirmed by

microscopic examination. Secondary sarcoma from the vagina has been reported three times.

Billroth's justly celebrated case of myxo-sarcoma and carcinoma, and another case of fibro-sarcoma, are the only instances of mixed growth that have been reported.

**Symptoms.**—The classical symptoms of tumor of the bladder are hæmaturia, irritable bladder, and pain. In ten of the twenty-two cases whose histories I have collected, hæmaturia was a symptom. Aside from villous growths, tumors of the bladder in children are not attended with hemorrhage, as a rule. Hæmaturia, when it occurs, is an important symptom. In villous growths it appears early and varies greatly in amount. It may be but a few drops at the end of the act of urination, or may be sufficient to endanger life. The hemorrhage is not dependent upon the size of the tumor. Exercise does not increase the amount or frequency of the bleeding. Hæmaturia is nearly always a late symptom of malignant tumor if it appears at all after breaking down has commenced.

Irritable bladder is always present. It may vary with the situation and size of the growth, tumors situated at the neck causing much more irritation than those at the fundus. Pain is usually present, and is similar to that arising from stone. Combined with the irritability, it keeps the patient in a most deplorable condition. A mild degree of cystitis occurs from the irritation of a foreign body. Retention of urine may occur from mechanical obstruction. In the female the body of the polypus may be projected from the urethra by some straining. An examination of the urine will often determine detached villi or fragments of the growth.

**Diagnosis.**—When the tumor is projected from the urethra, or villi are demonstrated in the urine, the diagnosis is easy. Not so with the greater proportion of cases. The symptoms are very often obscure, and are those common to other genito-urinary affections. When the tumor is encrusted with salts the differential diagnosis between it and stone will be impossible. The searcher must be employed with great circumspection. It may provoke in the tumor a very free hemorrhage. On the other hand, it will often clear up an obscure case very readily. A careful and repeated examination of the urine will often be rewarded by the discovery of fragments of the growth. As there is no specific cancer-cell, isolated epithelial cells have no diagnostic value. In Billroth's case the tumor could be easily felt above the symphysis pubis. Where symptoms persist although a positive diagnosis cannot be made, an exploration is desirable.

**Prognosis.**—At present no data can be found upon which to base a prognosis. Until recently few operations were undertaken for the relief of vesical tumor. Surgeons were content to palliate and temporize. Under the old method of treatment the prognosis was bad. Of the twenty-two cases reported, seventeen died and five recovered. Operations were undertaken in ten cases. Billroth's case, a boy twelve years old, recovered. Two others recovered through the accidental removal of the growth in the eye of



a catheter. In the other two cases of recovery, occurring in females, the urethra was dilated and the tumor removed. Cases are likely to be complicated by cystitis, ureteritis, pyelitis, and pyo-nephrosis. In malignant tumor the cachexia develops.

The revival of supra-pubic cystotomy and the growing tendency of surgeons to interfere actively in cases of vesical tumor will improve very greatly the prognosis of this hitherto fatal disease. Aside from malignant growths, the mortality ought not to be above thirty per cent.

**Treatment.**—Operative treatment in cases of simple tumor of the bladder gives the only hope of cure, and in all cases it affords temporary relief. Sir William MacCormac, in the discussion of the relative merits of supra-pubic and of perineal cystotomy, said, "I believe that in children the greatest future development of supra-pubic operation will occur." In childhood the bladder is nearly an abdominal viscus. From reasoning it would seem that supra-pubic cystotomy is the better operation in children. The use of the colpeurynter raises the bladder well out of the pelvis.

When an operation has been decided upon, the utmost care must be taken to place the patient in the best possible condition. The bowels should be freely opened by laxatives or enemas. Attention should be paid to the state of the urine, and every effort made to render it aseptic and acid. The site of the operation should be shaved and made thoroughly aseptic. The following instruments are necessary: a continuous-flow syringe, a small rectal colpeurynter, a scalpel, half a dozen pressure-forceps, a grooved director, two large full-curved Emmet needles, long polypus-forceps, a wire *écraseur*, a Volkmann's spoon, curved scissors, a good cautery, a sponge-holder, a retractor, drainage appliances, catgut, chromic acid, solution of subsulphate of iron, etc. A good apparatus for illuminating the bladder will be useful.

The anæsthetic having been given, the colpeurynter is introduced into the rectum and distended with not over five ounces of water. The bladder may be moderately distended with warm boro-salicylate solution. A hard pillow being placed under the pelvis, the abdominal viscera will gravitate away from the bladder. The first incision, from two to three inches long, should clearly divide the skin, fascia, cellular tissue, and *linea alba* from above downward to the border of the symphysis pubis. The recti muscles should be separated with the handle of the scalpel, when the transversalis fascia may be picked up with a forceps and divided upon a grooved director. The perivesical fat, behind which lies the peritoneum, should now be gently lifted upward with the finger, exposing the bladder. The site of the incision having been selected, two loops of strong silk should be passed through the bladder-walls by means of the Emmet needles, for the support of the bladder. These loops should be intrusted to an assistant. The incision into the bladder large enough to admit freely the index finger should be made with a knife, and quickly followed by the exploring finger, so that a knowledge may be gained of the character of the tumor and its attach-

ments before the fluid escapes. The method of removal—by the forceps, spoon, or *écraseur*—will depend largely upon the attachments of the tumor. Each case will require more or less operative ingenuity. Hemorrhage may be very embarrassing: a firm sponge-probang dipped in a solution of sub-sulphate of iron and applied to the base of the tumor for a moment will in most cases control it. When the hemorrhage is controlled, a small electric light can be used with advantage in the exploration of the bladder, especially if the pelvis is raised high. In every case where possible, the base of the tumor should be thoroughly destroyed, for which purpose there is nothing more satisfactory than the galvano-cautery. Chromic acid may be used, but it is difficult to localize its action.

The question of the closure of the wound must be decided for each case separately. Where the mucous membrane of the bladder presents no gross evidence of inflammation and the traumatism is not very great, the bladder should be closed. In the severer cases the method pursued by Prof. Hunter McGuire—namely, the establishment of a urinary fistula above the pubes—seems most feasible. A small male catheter may be left in the fistulous tract for a few hours, until the borders of the wound glaze.

In the after-treatment the patient may be allowed to assume any positions he chooses. The diet should be bland, chiefly milk. Careful attention should be paid to the urine, keeping it acid, if necessary, by the use of acid drinks. Acid urine is aseptic urine. The wound will require frequent changes of dressing to keep it clean.

In the female, small pedunculated polypi situated near the neck may be safely removed by dilatation of the urethra and the use of the forceps or the snare.

# DISEASES OF THE UMBILICUS.

By WILLIAM LEE, M.D.

---

As upon the proper management and treatment of the umbilical cord largely depends our ability to avoid many accidents which are incident to its separation, no apology is needed for opening this article with a short treatise on the subject. Indeed, it would seem that too much cannot be said in order to induce the careless physician to attend personally to the management and treatment of the cord, and not—as is too often the case—be eager to throw on the monthly nurse the whole responsibility of dressing, etc., of the cord.

In the first place, as a rule, great hurry should not be made to complete the interruption of foetal circulation; the better practice being to delay a few moments, until the cord collapses and the baby cries.

In applying the ligature, it should be remembered that a thin ligature is liable to cut through the walls of the blood-vessels, and, again, that a thick one will not produce sufficient compression. Not less than three inches should be the distance from the abdominal walls for applying the first ligature, in order to avoid the possible evil effects of the immense muscular power exerted by the umbilical arteries on the inside of the abdominal cavity. The second ligature should be applied one inch from the first, to prevent the oozing of blood on the bedclothes, and the cord cut between them.

According to Dr. A. Jacobi, it is a good rule to apply an additional ligature between the first and the abdominal wall, to avoid hemorrhage, which may take place after the cord has commenced to shrink, from the insufficiently compressed arteries. When tying, avoid pulling on the cord, and keep it as dry as possible.

In cases where the cord is very thick and vascular, my rule is, to sever before the ligature is applied, and, if possible, empty the cord of blood and serum, as by this means the amount to be sloughed off can be decreased. I then tie, and twist it three or four times, for the purpose of so closing the umbilical vessels as to insure against hemorrhage if the ligature should prove insufficient.

When the cord is severed, its abdominal end should be encircled with a soft piece of linen, covered with a pad of disinfected cotton, and secured on

the left side of the abdomen by a flannel bandage wide enough to go over the large part of the chest and abdomen, so as to prevent slipping.

In dressing the cord, all oily or greasy substances must be prohibited, and it must not be allowed to remain wet from urine or otherwise, as in either case, instead of desiccation, there will be decomposition of the cord and inflammation may extend to the navel.

The habit which most nurses have of constantly examining the cord after it is dressed must be forbidden, as it is in this way, I am satisfied, that septicæmic troubles often have their origin: it should be examined only in the presence of the attending physician. The usual time at which the cord shrivels is from two to four days, and this, if nothing prevents, is followed by its rapid desiccation, and falling off between the fourth and the eighth day. No infallible rule can, however, be laid down, on account of the nature of the cord and the particular constitution of the children. A soft, large, and fat cord shrivels slowly, even suppurating at its base before separation; while, on the other hand, a thin, small cord will often dry up early and become transparent, show the dried vessels, and separate without suppuration.

Various theories have been advanced in regard to the detachment of the cord: according to Haller and Munro, it is due to a kind of gangrene; Gardin considers it the result of constriction of the epidermis; Chaussier ascribes it to an inflammatory process; and Billard, to traction of the abdominal muscles which separate the navel from the dried portion of the cord.

When final separation of the cord is completed, the child's abdomen presents an infundibuliform depression, with a more or less decided ridge, formed by the skin, which is still a little reddened or inflamed, and there remains a slight oozing which soils the linen: the cicatrix is not perfect and entire until the tenth or the twelfth day. Should the cicatrization be very slow, a small quantity of some stimulating powder can be dusted on the part, as bismuth subnitrate, salicylic acid, iodoform, etc. Carbolic acid, as first stated by Dr. A. Jacobi, must not be used in treating abrasions, etc., of infants, as they are very susceptible to its poisonous properties. Neither should we use perchloride of iron, as the hardened coagulated mass formed by its application favors accumulation of secretions, which becoming absorbed give rise to sepsis.

If no unforeseen accident occurs, the navel, after the twelfth day, becomes more and more formed, and the umbilical vessels contract, drawing the cicatrix inward, so as to depress it, while externally the plumpness of the child causes it to appear still further depressed.

The cicatrix should be bandaged not only upon general principles, but also because in this way umbilical hernia can be obviated by protecting the abdomen and avoiding a strain when the child cries, coughs, or is handled roughly.

## THROMBOSIS, PHLEBITIS, SEPTICÆMIA.

After the cord is ligatured, the greater portion of the blood in the umbilical vein flows into the circulation, and that remaining forms into small clots or thrombi, which, upon contracting, harden and remain inert, or soften and dissolve. Should, however, the formation of these clots or thrombi terminate in thrombosis of the umbilical vein, putrefactive changes may take place, and particles of the disintegrated fibrin enter the circulation and produce phlebitis, embolism, or septicæmia in its worst form.

The best exposition of the history of thrombosis and the action of thrombi is that given by Prof. Ernst Ziegler,<sup>1</sup> who writes as follows on the issues of thrombosis.

“The fully-developed thrombus is a somewhat firm and dry mass adhering to the lining membrane of a vessel or of the heart, its color and structure varying as we have described. The comparatively small quantity of liquid it encloses is explained by the fact that the fibrin after its separation always shrinks, and so squeezes out the liquid from its meshes. This shrinking, when it occurs in an obliterating thrombus, may leave the channel of the vessel open once more. In many instances the contraction due to shrinking is very considerable. The fibrin is transformed into a dense mass, which may persist unchanged for a long time and ultimately becomes calcified. It is thus that the chalky concretions called phleboliths are formed in the veins. In the same way thrombi which are seated on roughened surfaces in the aorta or valves of the heart may become calcified, and may become sheltered from secondary deposits by the growth of an endothelial covering over them.

“Contraction with calcification is what we may call a favorable issue of thrombosis. The very common issue of thrombosis in softening is much less favorable. Softening is distinguished as simple or red softening and puriform or yellow softening. In simple or red softening the central parts of the thrombus are first of all changed into a grayish or reddish pulp, consisting of broken-down and shrunken red corpuscles, pigment-granules, and colorless granular detritus. If the softening then extends to the surface-layers, and if the blood-current is still flowing over the thrombus, the products of disintegration may be carried into the general circulation. This occurs both in the case of cardiac polypi and in vena thrombosis, especially when the tip of a thrombus projects from the orifice of a small vein into the channel of a larger, in which the blood is still flowing.

“The most unfavorable issue of all is the puriform or yellow softening of the thrombus. In this case the thrombus is transformed into a dirty- or reddish-yellow, fetid, pus-like cream or pulp. This contains a multitude of pus-corpuscles and a large proportion of a finely-granular matter,

---

<sup>1</sup> Text-Book of Pathological Anatomy and Pathogenesis, Wood's Library, Part II. p. 10.

which consists in part of fatty and albuminous detritus, and in part of micrococci. The latter frequently form groups or colonies, and are probably to be regarded as the exciting cause of the softening process. Such puriform thrombi act destructively on the surrounding tissues and set up inflammation. The intima of the vessel becomes turbid or opaque, and suppurative inflammation begins in the tunica media and tunica adventitia, extending to the tissue enclosing the vessel. Soon the entire thickness of the vessel-wall is infiltrated and takes on a dirty-yellowish or grayish appearance. Ultimately the tissues undergo putrid disintegration. If the puriform matters are carried by the blood-current to distant spots, they there produce necrotic and putrefactive changes in the tissues and set up suppurative inflammation. The entire process, in which puriform softening of a venous thrombus is associated with suppurative inflammation of the vessel-wall, is described as purulent thrombo-phlebitis. It is due in the first instance to the causes which lead to the thrombosis, and in the second to the access of micrococci to the thrombus. In the other cases the inflammation of the vessel-wall is primary, and the thrombosis a secondary effect. The purulent form is most commonly met with in the neighborhood of septic wounds and ulcers. The most favorable issue of thrombosis is in organization of the thrombus. By this is meant the replacement of the fibrin and corpuscles by vascularized fibrous tissue."

Phlebitis is usually caused by the entrance of air into the umbilical vein from the umbilical fossa, which, becoming impregnated with germs from the atmosphere, gives rise to the products of inflammation of the vein and of the tunic of which it is composed. Again, direct infection may take place through the vein, in consequence of an ulcerative process commencing about an inch above the navel. At times it is the result of congestion occurring in connection with icterus neonatorum, in which condition we often find the vein filled with pus, giving rise to septicaemia, pyaemia, erysipelas, peritonitis, or cutaneous abscesses. Both phlebitis and septicaemia may arise from soiled fingers, cloths, applications of various kinds, and septic infection from mother or infant, as decomposed lochial discharges, or blennorrhoea oculi neonatorum.

**Symptoms.**—Besides local inflammation of the vein, the moment the disease is contracted and the infection commences, the child has a chill, high fever, the temperature often running as high as 105° F., loses its appetite, and is constipated. The abdomen becomes hard and painful, particularly in the region of the affected portion of the vein, and, should the inflammation be superficial, a red, livid discoloration is easily seen in the integument over it, and pus is found at the base of the umbilicus. Should the inflammation increase, peritonitis is developed, particularly if it occurs in connection with icterus.

**Prognosis.**—In cases where the amount of poison absorbed has not been great, and the eliminative process not very seriously interfered with, recovery is possible.

**Treatment.**—Antiseptic measures must be rigorously enforced from the first, and such special treatment adopted as may be indicated. If pus has formed in the vein, it should be squeezed out and the vessel injected with a mild antiseptic; umbilical wounds should be dressed with disinfecting and stimulating remedies, such as resorcin, bismuth, boracic acid, salicylated cotton, or deodorized iodoform,—resorcin being the best, from the fact that it possesses a special power of preventing putrefaction. I called attention to the antiseptic power of this drug at a meeting of the American Medical Association held at St. Paul in 1883.

Should the mother be suffering from septic poison, the infant must be attended to first, and, if possible, be kept out of the room, at least for two weeks after her confinement. All cloths, sponges, and instruments to be used for the new-born must be carefully disinfected. Internally small doses of calomel are indicated to relieve the constipation, and, that failing, warm-water injections. Generous feeding must be enforced (by a wet-nurse if possible), and alcoholic stimulants insisted upon. (Children take larger proportional doses of stimulants than adults, and with less injurious effects.)

#### FUNGOUS GROWTHS AND GRANULATIONS OF THE UMBILICUS.

During the first two weeks, and even later, we sometimes find granulating growths cropping out from within the depression of the umbilicus. They appear either as a small polypoid body or as a solid hard tumor, and are usually of the size of a pea.

If not removed promptly, these growths increase in size, and emit a bloody serum, which causes inflammation and makes complete cicatrization of the umbilical stump impossible.

**Treatment.**—When the growth is pediculated, a small ligature should be carefully passed around its base, and allowed to remain from four to six hours, after which the growth is to be removed in mass with a pair of seissors having blunt points in order to avoid accidents. I use a pair similar to those employed in the operation for tongue-tie.

After removing the growth, touch the stump with a mild styptic and apply over it tightly a pad of disinfected absorbent cotton.

On the other hand, if the tumor is solid and hard, it must be removed by means of cauterization, using for that purpose Paquelin's thermo-cautery or some judiciously selected caustic preparation.

#### UMBILICAL HEMORRHAGE.

Should the umbilical cord shrink and dry up promptly, we have as a result a cicatrix,—which is the umbilicus. Unfortunately, however, this is not always the case; nature's work is interfered with, and we have, instead, hemorrhage, from either the cord or the navel.

**Causes.**—These hemorrhages originate from violent traction on the cord in the process of labor, particularly if the cord is short or wrapped around the child's neck. These accidents are comparatively rare, however, hemor-

rhage occurring, as a rule, either during the last days of the separation of the cord or at a still later period. It may, too, be the result of bad ligaturing, or of disease of the funis, such as an ossified or varicose state of the vessels; again, it may be due to an incomplete closure of the vessels. Malformation or occlusion of the gall-ducts is a fruitful cause of these hemorrhages; so also is the accumulation of bile in the blood, whether from absence of the ducts or from some abnormal condition of the liver which causes suspension of its functions. Associated with bleeding from the navel or cord we may find the hemorrhagic diathesis, as evinced by epistaxis, hæmatemesis, mælena, and purpura hæmorrhagica, the latter being most probably the cause if ecchymoses or petechiæ are found on the lower limbs, the abdomen, and the arms at the time of the umbilical hemorrhage. The following cases will serve to illustrate the manifestation of this hemorrhagic diathesis, also the fatality of umbilical hemorrhages.

*Case I.*—Mrs. McC. was delivered of her eleventh child—male—January, 1886. The infant was apparently healthy and well nourished, but supposed to have been born three weeks before term. When one week old a hemorrhage from the umbilicus occurred, which proved fatal in about six hours. The blood first came in jets and from the right side of the cord.

*Case II.*—On May 20, 1888, Mrs. McC. gave birth to her twelfth child—also a male—at full term. The infant was well nourished and healthy. On the morning of the sixteenth day umbilical hemorrhage occurred, the child dying on the second day of the attack, during which time it had four or five hemorrhages. In this case the blood came from all around the navel, was bright in color, and coagulated slowly.

*History.*—The mother, who had always had natural labors, showed no evidence of tubercular, syphilitic, or other hereditary disease, nor had there, to her knowledge, been any in her family. She, however, complained of being annoyed with frequent attacks of epistaxis, from which, beyond a slight weakness immediately after the bleeding, she suffered no bad effects. The father was healthy, never having been seriously ill. The family were in comfortable circumstances, and out of the twelve children there are seven living, four males and three females. All of the seven are subject to free and frequent epistaxis, the attacks being more frequent with the daughters.

*Case III.*—In January, 1885, Mrs. S., a chlorotic woman and a victim of uterine disease in its chronic form, was delivered of a quite healthy-looking child. It passed naturally meconium and made water, but shortly after vomited slimy fluid, and was unable to retain food in its stomach long. The infant had from the time of passing the meconium no further action of its bowels, even after injection; its skin gradually assumed a saffron color. The cord came off at the end of the eighth day, and cicatrization of the stump took place without any trouble. On the tenth day the nurse found stains of blood on the right side of the navel, to which I at once applied borate of starch, and no further bleeding took place until the next day, when it became profuse. The umbilical depression was now packed with cotton which had alum previously dusted into it, and the pad secured by a well-arranged bandage, the hemorrhage, however, being controlled but a short time. I next, after gathering up the integument around the umbilicus, transfixed the parts with two needles, and applied strong ligatures, tying them beneath; still the blood oozed, but there was no more decided bleeding. From this time, which was the fourth day, the infant still had spells of vomiting, ejected matter light green in color, became very jaundiced, and died on the fourteenth day.

*Autopsy.*—Two hours after death the veins and arteries were found to be full of clots. The bladder was very much inflamed. Peritoneum congested, also portion of the small intestines; cæcum packed with fecal matter, thick, and of dark-green color. Stomach filled with greenish liquid. Gall-bladder distended with bile; biliary duct pervious. Liver very



large, particularly the right lobe, and, when cut open, its secretions were very yellow and adhered to the fingers like paste.

Occasionally cases of umbilical hemorrhage are found to be caused by fatty degeneration of the liver, heart, or kidneys, there being a complete breaking down of the blood-vessels. Both jaundice and inherited syphilis are frequent causes of this form of hemorrhage, if not the most frequent cause. Jaundice is a prominent cause, not only because of the impoverished condition of the blood (its globules and fibrin being much below the standard), but possibly also on account of the great accumulation of bile in the system resulting from obstruction of the hepatic or of the common duct. With regard to inherited syphilis, we have, besides the morbid state of the blood acting as a favorable agent to excite umbilical hemorrhage, the various local manifestations of the disease or cachexia from which the new-born suffers.

*Sex.*—Males are more liable to these hemorrhages than females, the proportion being sixty-six males to thirty-five females.

*Age.*—In one hundred cases the ages at which hemorrhage occurred were as follows :

First day . . . . .	4 cases
Second day . . . . .	8 "
Third day . . . . .	7 "
Fourth day . . . . .	6 "
Fifth to sixth day . . . . .	28 "
Sixth to twelfth day . . . . .	20 "
Twelfth to sixteenth day . . . . .	21 "
Sixteenth to twenty-fourth day . . . . .	4 "
Twenty-fourth to sixtieth day . . . . .	2 "
	100 "

**Symptoms.**—As has been mentioned before, there is more or less oozing of blood during the separation of the cord, according as it is thin or large in size : should, however, the oozing be considerable, we have, as a complication, hemorrhage. Ordinarily the bleeding occurs suddenly without premonition, unless brought about by jaundice, inherited syphilis, or a hemorrhagic tendency.

When hemorrhage ensues, the blood at first flows in an intermittent, dribbling manner, the first evidence being the detection of spots of blood on the child's linen by the mother or nurse, and on further examination a bleeding surface is revealed around the seat of the navel. This bleeding, although appearing superficial, comes from the bottom of the umbilicus, which soon is filled with a putrescent substance mixed with blood. This rapidly increases to hemorrhage pure and simple, and before we are aware the child is exsanguinated despite our best efforts. When umbilical hemorrhage has associated with it jaundice, besides the icteric hue constipation is always present, the stools are white and clay-colored, and the urine is deeply stained with bile. This form of hemorrhage begins at the root of the cord at the time of its separation.

In case of hemorrhage due to malformation of the gall-ducts, the bleeding oftenest occurs first at night, beginning generally from a few hours to a day or two after the navel-string has fallen off. The blood flows with more or less violence, and is most frequently arterial.

**Autopsy.**—In the details of one hundred post-mortems where death had ensued from umbilical hemorrhage, in twenty-five cases the bile-ducts were absent; in twenty they were open, but there was an abnormal condition of the liver; in thirty the bile-ducts were entirely obliterated and their place was occupied by a small quantity of areolar tissue; in fifteen the bile-ducts were impervious; in ten there was fatty degeneration of heart, liver, and kidney.

**Prognosis.**—In nearly all instances the prognosis is bad; the exceptions to this rule are those cases in which the family history is good. The cases most apt to be fatal are those in which the hemorrhage proceeds from or is connected with general septicæmia, jaundice, congenital syphilis, or purpura hæmorrhagica. The duration of life in fatal cases ranges from two to six days.

**Treatment.**—If the bleeding is slight it may easily be arrested, but even then we must not lose sight of the possibility of hemorrhage recurring at any moment. A good rule, and one which I always adopt, is to instruct the nurse how to pinch up the umbilicus between her fingers and by firm pressure control the bleeding until assistance arrives.

Hemorrhage can sometimes be stopped by injecting a mild styptic into the open vessels and applying a suitable compress. In all cases constitutional as well as local measures must be resorted to.

Internally Dr. J. Foster Jenkins recommends small doses of calomel, not only for its laxative effects, but also because the remedy acts as a derivative. When there is a hæmorrhagic diathesis, *nux vomica* often does well; also iron,—preferably the tincture of the chloride, to which may be conjoined either *ergot* or *digitalis*. The most useful local remedies are alum, borated cotton, styptic cotton, cold or hot applications, nitrate of silver, plaster-of-Paris cuirass, and lint soaked with the perchloride of iron.

Failing to suppress the hemorrhage by ordinary measures, we finally resort to the more effectual,—namely, that of transfixing the integument at the base of the cord, so as to include the umbilical vessels. This is done by passing through the parts, at right angles, two well-carbolized hare-lip pins or needles, and securing them tightly beneath with strong ligatures wound in the figure-of-eight form.

At the end of five or six days remove the needles and apply oxide of zinc or some simple ointment.

# DISEASES OF THE TESTES AND PENIS:

HYDROCELE; RETAINED TESTIS; TUMORS OF THE TESTICLE; BALANITIS; URETHRITIS; MASTURBATION.

By F. R. STURGIS, M.D.

---

## HYDROCELE.

THE testis is covered by two tunics, which are known respectively as the tunica vaginalis and the tunica albuginea. The tunica vaginalis is a closed serous sac which is derived from the processus vaginalis peritonei, and is divided into two layers,—the visceral and the parietal. The first of these lines the scrotum, and the second envelops the testis and is in close relation to the tunica albuginea. At the birth of the child the connection with the peritoneal cavity which formerly existed is usually closed, but sometimes this is not the case. This portion of the tunica vaginalis envelops the head and body of the epididymis, and in the normal condition contains a few drops of serum between the two layers.

**HYDROCELE OF THE TESTIS.**—Hydrocele is defined as an effusion of serum between the two layers of the tunica vaginalis, and in infants and children may be divided into the congenital and acquired varieties. Congenital hydrocele is due to a more or less incomplete closure of the processus vaginalis peritonei, which allows serous fluid from the peritoneal cavity to settle in the vaginal sac. The acquired variety is due to the accumulation of serum from inflammatory or other causes between the parietal and the visceral layer of the sac.

**CONGENITAL HYDROCELE** is due, as stated above, to non-closure of the canal leading from the abdominal cavity into the scrotum. This canal is sometimes wide and at other times narrow, and admits of fluid being passed from the scrotum into the abdominal cavity, and *vice versa*. It may be mistaken occasionally for hernia, but the only point of resemblance is the fact of its reducibility, and it is easily distinguished by its translucence, the feeling of tension and elasticity, and the absence of the gurgling which is nearly always present if intestine has passed into the scrotal cavity; it is furthermore to be distinguished from an omental hernia by the difference in the feeling of the two, by the absence of the firmness and hardness which

characterize an omental hernia, and by its capacity for transmitting light. Sometimes the testicle bulges out the posterior portion of the scrotum, from pressure of the hydrocele above, and sometimes the testicle is retained in the belly or the inguinal canal, from the pressure of the enclosed fluid in the serous sac beneath.

**ACQUIRED HYDROCELE.**—In acquired hydrocele the accumulation of serum between the layers is due sometimes to injury or inflammation and sometimes to closure of the communicating canal between the tunica vaginalis and the abdominal cavity, thus converting the congenital into the acquired form.

This variety may be either acute or chronic, the latter being usually the sequence of the former. During the acute stage there is comparatively little change in the condition of the sac, and the fluid is clear and serous. But when it becomes chronic the walls of the sac are thickened and lined with false membrane, and the fluid becomes turbid and albuminous. If during the chronic stage acute inflammation supervenes, cure may result from the absorption of the fluid and cohesion of the walls of the sac; but in some instances this cohesion is only partial, and the hydrocele then becomes what is known as the sacculated variety. Sometimes blood is effused into the cavity of the sac from an injury, such as a blow or fall, and then there is produced what is known as hæmatocele.

**HYDROCELE OF THE CORD** is caused by a collection of fluid in the middle portion of the processus vaginalis. If the processus vaginalis is closed above and below, the hydrocele is of the encysted variety; but if the opening with the abdominal cavity still exists, it is called a communicating hydrocele. An encysted hydrocele of the cord may reach from the internal ring into the scrotum, and is then known as a complete encysted hydrocele; but if the hydrocele is only partial, it is intra- or extra-inguinal, according as it is within or without the inguinal canal. This kind of hydrocele assumes various forms, being oblong, spindle-shaped, or round.

*Hydrocele herniosa* is simply a hydrocele of the cord which is complicated with an inguinal hernia.

**Causes.**—The congenital variety of hydrocele is common during the first year of extra-uterine life, and forms a large proportion of the hydroceles seen in young children. It is probably due to intra-uterine changes which are not as yet completely understood. The acquired form is rarer in children than the congenital, and is due to pressure or injury or is a sequence of some disease of the testicle. Hydrocele of the cord is caused by a patent condition of the processus vaginalis peritonei, and is sometimes the result of perispermatitis, of local injury to the cord, or of retained testis. It is present in ten per cent. of all cases of hydrocele, and is found usually in the first year of extra-uterine life, sometimes in the second, and very rarely later on.

**Symptoms.**—The principal symptom of hydrocele is the presence of a swelling in the scrotum which is elastic and transparent if the contents of

the sac be serous, and gives a decided sense of fluctuation. If the hydrocele is congenital, the fluid can be compressed into the abdominal cavity and the scrotum emptied, sometimes giving rise to a question of hernia. If, on the other hand, the hydrocele is of the acquired type, the sac is closed, does not communicate with the abdomen, and cannot be emptied; upon examination with the fingers, the abdominal rings can be distinctly felt; the testicle in these cases, lying at the posterior portion of the sac and a little high up near the ring, can be readily detected, provided the sac is not excessively distended, but even then a careful examination will never fail to discover it unless the testis be absent or retained (as is sometimes the case) in the inguinal canal or abdominal cavity. The scrotum is seldom, if ever, inflamed.

Hydrocele of the cord gives rise to an elastic, painless swelling, of varying shape, from circular to spindle-shaped, and fluctuates on palpation. It is irreducible unless there be a communication with the abdominal cavity. In this case the fluid can be pressed out of the sac, but returns immediately on the patient's coughing, making forced expiration, or assuming the erect position. This form of hydrocele may also be complicated with hernia or with a tumor, from the former of which it is distinguished by its translucency, its greater sensation of fluctuation, and the absence of gurgling; from the latter, by the absence of the firmness and opacity which are usually present with tumors. Of course in these cases due attention will be paid to the possibility of the tumor being a retained testis, and, should the testis be in the scrotum, if any question as to the character of the swelling still exist, an exploratory puncture may be made. Multilocular cysts of the cord are of very rare occurrence in infants and young children.

**Prognosis and Treatment.**—The prognosis in hydrocele of both testis and cord is usually good, especially in the congenital variety, which tends to self-cure more frequently than the acquired. A good rule to observe in these cases, whether congenital or acquired, is to delay operation as long as possible. Sometimes a communicating hydrocele may be hastened towards recovery by the wearing of a light truss, which excites inflammation and closes the canal. If operative procedures are deemed necessary (and this is more particularly the case in the acquired type), various methods may be employed,—to wit:

*Painting the scrotum* with a weak solution of iodine in collodion, or with a dilute solution of nitrate of silver in collodion, or with Goulard's lotion, or with alcohol and collodion, or with the iodide-of-lead ointment, in order to excite absorption of the fluid. These local applications are seldom of much use, except when the exudation is very slight.

*Acupuncture.*—This may be done by puncturing the sac with the needle, evacuating the fluid, and painting the scrotum with collodion to exercise some compression (this latter is not always necessary); or the sac may be punctured with a trocar, and a weak solution of iodine, tincture of iron, chloroform, or alcohol injected into it. A seton passed through the sac is sometimes of service. Finally, a free incision into the scrotum, if

carefully made, with due antiseptic precautions and strict attention to cleanliness, is usually successful, even after all the preceding measures have failed. Electro-cautery or opening into the sac by caustics is of little advantage, and is much more severe than the other methods advised.

HEMATOCELE is simply an infusion of blood into the sac from an injury or from rupture of a vessel, and is exceedingly rare in infants and children. Its causes are nearly always due to some local hurt, such as a blow or severe compression.

**Treatment.**—The treatment is at first expectant, in the shape of cold applications and painting the scrotum with collodion. If, however, the hemorrhage has been very abundant, it is better to open the sac at once, clean out the clot, tie up any vessels which may have caused the hemorrhage, and allow the parts to heal, which they will usually do with great rapidity.

#### RETAINED TESTIS.

It sometimes happens that the testicles do not descend from the abdominal cavity, which condition is called cryptorchism where both testes are retained, and monorchism where only one is absent from the scrotum. These organs leave the abdominal cavity, but, instead of dropping into the scrotum where they belong, one may lodge in the anterior wall of the abdomen, in the femoral canal, or in the perineum. This displacement is known as ectopia testis, and is divided into the abdominal, crural, and perineal varieties. Sometimes the testes are congenitally absent, and again it may happen that these organs are not only retained in the abdomen but also united in the median line with the kidneys and suprarenal capsules, while the spermatic vessels, vasa deferentia, and vesiculæ seminales are normally situated, as occurred in a case mentioned by Geoffroy St.-Hilaire,<sup>1</sup> where the patient was considered to be a girl and lived for eighteen months.

Retention of the testes, whether partial or complete, is not uncommon in children, especially during early infantile life, but the testes usually descend by themselves if not too much interfered with. Ectopia is of quite rare occurrence.

**Symptoms.**—Examination of the scrotum usually reveals the absence of one or both testes, but on passing the finger up the inguinal canal these organs can generally be detected. Coughing, forced expiration, and the erect posture cause the testis to descend on the point of the finger placed in the inguinal canal. Usually examination excites no pain unless pressure be made on the testis.

If the testicle is caught in the inguinal canal, the child complains of pain when sitting, standing, or crossing its legs; and, on examination, the scrotum is found partially or completely empty, and the testes are felt in the inguinal canal. The absence of these organs from the scrotum should always prevent the surgeon from mistaking a retained testicle for a hernia.

<sup>1</sup> Histoire des Anomalies de l'Organisme, tome i.

In ectopia testis the organ is usually felt in the abdominal wall, in the groin, or in the perineum, according to its position, and the diagnosis, of course, is comparatively easy.

**Course.**—The course of the disease is generally favorable, as the testicle usually descends of itself, but sometimes it happens that it does not, when if it is lodged in the inguinal canal it may become atrophied. In cases where the descent does not occur within the first year of infantile life, it is usually associated, when it does come down, with a congenital hernia. Adhesions may also occur between the testis and circumjacent parts, particularly when it is lodged in the inguinal canal, and in such cases the result is a fibrous or fatty degeneration of the organ. Sometimes it is attacked with inflammation ending in suppuration, when the testis, of course, is lost.

**Causes.**—The causes which induce retention of the testis are due sometimes to an arrest of development, and sometimes to mechanical hinderance to its descent. Small and narrow abdominal rings, premature closure of the canal, non-communication between the scrotum and the abdominal cavity, shortness of the vas deferens, marked hypospadias or epispadias, with ectopia vesicæ and various forms of hermaphroditism, may be enumerated among the causes. In one case mentioned by Birch-Hirschfeld the retention was caused by the right kidney blocking up the inner opening of the inguinal canal, and Hunter speaks of hypertrophy of the testis as being an obstacle in another case. An abnormally enlarged epididymis and an abnormal formation of the mesorchium are also enumerated as causes. Kocher mentions a congenital displacement forward of the large intestine as an obstacle to the descent of the testicle. Retention can also be caused by a lack of proper apposition of the testis in its relation to the inguinal canal, and by a defective development of the cremaster muscle during foetal life.

The causes of ectopia testis are somewhat obscure. It is said to be congenital, especially the perineal variety, and to be due sometimes to an insertion of the gubernaculum testis in the wrong place, sometimes to an arrest of development in the affected half of the scrotum, and occasionally to traumatism.

**Treatment.**—In the majority of cases, and particularly in early life, expectancy should be the rule and surgical interference the exception. If the testis is lodged in the inguinal canal close to and protruding from the external ring, gentle traction may be adopted in order to facilitate the descent of the organ, which with a little assistance is sometimes rapidly completed. If the retention is due to a disproportion in size between the inguinal opening and the testis, gentle traction from behind the latter may sometimes assist it through the ring, and sometimes it may be necessary to enlarge the inguinal opening by a subcutaneous incision. Of course, in cases where non-descent is due to a short cord nothing can be done, and, provided it gives rise to no disturbance, the case may be left to itself. If due to adhesions within the abdomen, operative procedure is hardly admissible; but if due to adhesions in the inguinal canal, an incision may be

made through the upper part of the scrotum to the inguinal canal, the adhesions broken up, and the descent of the testis facilitated. Where fibrous, purulent, or fatty degeneration has occurred, the testis had better be left *in situ*, unless inconvenience or pain is experienced, in which case the testis had better be removed.

In cases of ectopia testis an operation will very often remedy the difficulty and the organ may be restored to its normal position in the scrotum.

A curious affection of the testes, to which attention was called by St.-Germain in the *Journal de Médecine et de Chirurgie pratique* for 1879, is said sometimes to occur in children in consequence of a severe fright or a blow. He has called it "Réascension du Testicule," and gives two cases in children where, after a blow attended with severe fright, both testicles suddenly disappeared in the abdominal cavity and remained there for a considerable time, in one instance during two months and a half. In both cases he practised gentle traction upon the cord, which was followed by a cure, the testicles reappearing in their proper places.

#### TUMORS OF THE TESTICLE.

**PERIORCHITIS.**—Periorchitis, or inflammation of the tunica vaginalis, is not a common affection in children, but is occasionally seen as the commencement of a hydrocele. The serous kind is generally divided into the acute and the chronic variety, but the dividing line between the two is not clear, as the former rapidly merges into the latter. The division which has been made into periorchitis plastica and suppurativa of the acute variety, and periorchitis adhesiva, prolifera, and hæmorrhagica of the chronic variety, is, to my mind, rather fantastic, inasmuch as they are really different stages of the acute or the chronic kind. Periorchitis is sometimes also associated with orchitis or epididymitis.

**Symptoms.**—Acute periorchitis often begins with a smart fever, accompanied by severe pain in the affected part, which extends over the spermatic cord. The scrotum is red, œdematous, and tender to the touch. The tumor is tense, fluctuating, and non-translucent, and of oval form or flattened sideways. If, as is not infrequently the case, it goes on to suppuration, the fever increases, accompanied by chills, the skin of the affected part becomes red, œdematous, and exquisitely tender, and the swelling either opens spontaneously or is artificially incised.

**Course.**—Serous periorchitis may end in resolution, leaving behind some thickening of the cord from plastic exudation. The suppurative kind nearly always requires to be opened and treated like an ordinary abscess. Sometimes, however, the inflammation runs a very acute course, extends along the cord, and may induce peritonitis with a fatal termination; but, as a general rule, the prognosis is favorable.

**Treatment.**—During the acute stage absolute rest should be enjoined, the cord on the affected side supported, and cold evaporating lotions used. On the subsidence of the pain mild compression may be exercised



by painting the part over with collodion, but I decidedly deprecate the use of strapping with adhesive plaster, as it not infrequently leads to atrophy of the testis and even ulceration and gangrene of the scrotum. Resolution may be further hastened by local applications of belladonna and mercurial ointment, either alone or in combination,—better the latter. The suppurative variety will need to be opened, when it can be treated like an ordinary abscess by the use of injections into the cavity and the employment of stimulating dressings.

**ORCHITIS AND EPIDIDYMITIS.**—These affections of the testicle may be divided into acute and chronic, and are due to inflammation of the testis proper or of the epididymis, or both; and these may still further be divided into the inflammatory, the symptomatic, and the constitutional type.

**Symptoms.**—Orchitis and epididymitis usually begin with high fever, chills, and swelling, which may attain to a large size. The fever, if very acute, may be complicated with vomiting, abdominal tenderness, and sometimes even a mild attack of peritonitis, particularly if the disease be also complicated with inflammation of the tunica vaginalis. The organ becomes enormously enlarged and is very tender to the touch; the scrotum is red and inflamed, not infrequently there is more or less hydrocele, and the testis is usually drawn up close to the abdominal ring. Under proper treatment this acute condition subsides, leaving behind the chronic variety, which is distinguished by enlargement of the testis or epididymis and thickening of the tunica vaginalis, without much tenderness. If there have been much plastic exudation, adhesions sometimes take place between the tunica vaginalis and the tunica albuginea.

The severity of the symptoms varies very much with the cause of the disease. Thus, if the orchitis or epididymitis be due to syphilis, there is not much pain, but the testis is enlarged, of stony hardness, and under these circumstances is not usually associated with hydrocele.

**Causes.**—The causes of this affection of the testis are injuries to the organ, urethritis, mumps, possibly an antecedent periorchitis, syphilis, typhus fever, small-pox, scarlet fever, and harsh attempts at catheterism.

**Course.**—If the orchitis be due to an injury, it usually runs a favorable course, provided suppuration does not occur. The swelling subsides, and the effusion, if serous, is absorbed. If, however, it be complicated with hæmatocoele, thickening of the sac generally remains. Cases have been known where a fatal termination ensued in the suppurative kind, from peritonitis and septicæmia.

If it be due to a clap, the swelling and various symptoms subside, but an induration results, especially if the epididymis be attacked. Sometimes, though rarely, atrophy results.

If it be due to syphilis, it ends unfavorably, as atrophy of the organ is nearly certain to occur. If it results from mumps or from the other causes mentioned above, the termination is usually favorable; but it is well to re-

member that atrophy may be the end of all these affections, although it is not necessarily so. In cases where it is due to injury from the use of a catheter, an abscess, with or without suppuration, may ensue, and in all cases where pus forms, the termination is usually in one of four ways,—to wit, resolution, fungus of the testicle, evacuation of the contents of the tunica albuginea, leaving the shell of the testis behind, or a more or less complete atrophy.

**Treatment.**—The treatment consists in rest, support of the testis, the application of heat or cold, as may be most agreeable,—the former is, to my mind, preferable,—leeches to the ring and to the inner sides of the thighs, puncture of the inflamed and swollen covering with an ordinary surgical needle, and the subsequent application locally of mercurial and belladonna plasters. In syphilitic orchitis the applications, leeches, and punctures may be omitted, and the patient should be treated by the internal and local administration of mercury and the administration of iodide of potassium by the mouth. In case of abscess of the testis the parts should be incised as soon as fluctuation is detected.

**NEW FORMATIONS IN THE TESTIS.**—Neoplasms of the testicle may be divided into those of tubercular, syphilitic, cancerous, sarcomatous, and chondromatous origin, fungus of the testicle, and cysts.

**Tubercle.**—Tubercle of the testicle appears as hard irregular- or oval-shaped nodules, which either undergo caseous degeneration or break down and suppurate. They may sometimes be mistaken for circumscribed gummata or carcinoma of the testis; but they differ from both of these by being attended with pain, inflammation, and fever, by the recurrence of the attacks, and by the absence of other symptoms, whether of syphilis or carcinoma. If the nodules suppurate, the abscesses may be either single or multiple, and, whether of one or the other variety, should be opened only after all methods looking towards absorption have failed. It is not a very common affection in children.

**Syphilis.**—This may be of the diffused or the circumscribed variety, but usually is of the former. It is of slow growth, and accompanied by other symptoms of syphilis which will assist oftentimes materially in the diagnosis. It may be either of the hereditary or the acquired type. If of the former, the child nearly always dies, not from the affection of the testicle, but from the depression consequent upon syphilis. The acquired variety nearly always terminates favorably (except so far as atrophy is concerned) under a proper treatment with mercury, either alone or in combination with iodide of potassium.

**Cancer.**—Cancer of the testicle may occur under three forms,—the medullary, which is the most common in early infancy and before puberty, the sarcomatous, the next most common kind before puberty, and the carcinomatous, the most usual after puberty. The encephaloid variety has also been seen in children aged one, three, and five years.

This affection of the testis is usually not attended with much pain or

inflammation, but the organ is enormously enlarged, bosselated, and its growth is generally slow.

The circumscribed variety of syphilitic testis may sometimes simulate a carcinoma of the testis, but the absence or presence of other symptoms of syphilis is usually sufficient to enable a differential diagnosis to be easily made. The cancerous testicle is usually oval in shape, but it may be irregular, and is frequently associated with infiltration of the glands in the groin and probably also of those in the abdominal cavity. The cancerous cachexia is frequently present in these cases, and the patient usually dies either from exhaustion incident to the breaking down and suppuration of the diseased testicle, or from cancerous deposits elsewhere. Removal of the testicle is sometimes done, in the hope of checking the disease, but the termination in these cases is generally fatal.

*Sarcoma.*—Sarcoma occurs during early infant life, and is divided into the two varieties of simple and medullary. It usually develops under the same conditions as carcinoma, runs a rapid course, and in some cases is attended from the commencement with severe pain in the organ, while in other cases the course is painless. It sometimes attains to quite a large size; it is not so fatal as the former variety, inasmuch as castration will sometimes arrest the course of the disease.

*Chondroma.*—Chondroma of the testis in infants and children is exceedingly rare. I believe that only one case has been reported,—the one of O. Weber's mentioned by Bökei in Gerhardt's *Handbuch der Kinderkrankheiten*, where it occurred as a congenital tumor and was at birth as large as a pigeon's egg, increasing in fifteen months to the size of a goose's egg. This neoplasm was made up principally of cartilage, and was generally hard and nodulated, with here and there points of softening. This enchondroma probably had its starting-point in the rete testis. In this infant there was found within the albuginea a broken-down spot which was filled with a matter resembling thick pus and which consisted of cartilage-cells undergoing fatty degeneration. Enchondroma of the testis is classed among the malignant diseases.

*Benign Fungus.*—Benign fungus usually commences as the result of inflammatory action, ending in suppuration either of the acute or the chronic variety, or of a tubercular nodule, and frequently implicates the scrotum. After the evacuation of the contents of the abscess, exuberant granulations spring up above the surface of the skin. If the fungus be of the simple variety, the granulations may be destroyed by the knife, by applications of the mineral acids and treatment of the resulting cavity with stimulant applications, and by the administration internally of tonics. If due to tubercle of the testis, removal of that organ is the simplest and best method after all other means have failed.

*Cysts.*—The curious neoplasms known under the name of dermoid cysts are nearly always of foetal origin and are considered to be congenital. They may be single or multiple, and, in either case, contain hair, teeth, bones,

muscular fibres, nerve-tissue, and sometimes even the greater portion of a fetal skeleton. An interesting paper upon this subject is given by W. Macewen in the *Glasgow Medical and Surgical Journal* for 1878.

#### BALANITIS.

Balanitis in infants and young children is a common affection, and may be divided into balanitis of the foreskin and balanitis of the glans penis. Where the latter only is attacked it is, properly speaking, a balanitis, and where it is associated with inflammation of the inner lamella of the foreskin it is known as balano-posthitis. Balano-posthitis, for I shall consider the two affections together, may be divided into the catarrhal, phlegmonous, croupous, diphtheritic, gangrenous, and exanthematous varieties, the most frequent of these being the first, or catarrhal variety. This occurs in the form of superficial inflammation of the mucous membrane lining the glans penis and the inner layer of the foreskin, and may be either general or circumscribed. If the inflammation be of a subacute character, the symptoms extend no farther than the mucous membrane; but if acute symptoms be prominent, then the skin of the genitals participates in the general inflammation, and the disease becomes a dermatitis as well as a balano-posthitis.

**Symptoms.**—Simple balano-posthitis usually commences with swelling and redness of the foreskin, with eversion of its mucous lining if phimosis be present, and is attended with much difficulty and pain to the child if retraction be attempted. In the earlier stages of the disease there is no discharge, however. If retraction can be made, the mucous membrane is found to be injected, of a deep red or purple color, and if there be any secretion, superficial erosions of the mucous lining of both foreskin and glans penis are found. After a short time, a purulent discharge can be pressed from beneath the foreskin, and this discharge is usually acrid and capable of producing much irritation, not only of the external covering of the genitals, but also of the skin of the inner portion of the thigh and of the groins. The sexual parts then become enormously swollen, and not infrequently the deep purple hue seems to threaten approaching gangrene. The secretion thus expressed commences as a thin, sticky, slightly yellow discharge, which upon exposure to the air rapidly dries and glues together the meatus and the free border of the foreskin. In older children this discharge becomes abundant and may readily be mistaken for a urethritis, especially as from the swollen condition of the foreskin it is impossible to examine the meatus and the anterior portion of the urethra. Of course such cases, both in infants and in grown children, may be associated with a urethritis; and where the urethritis is the real cause, a balano-posthitis may be induced from want of cleanliness or from lack of proper attention and treatment.

**Causes.**—This variety of balanitis is in the large proportion of cases due to a want of cleanliness. The retention of the smegma or of the last few drops of urine in such children as have an elongated foreskin—and

this is the case in the vast majority of children—induces decomposition of the secretion and inflammation of the mucous membrane, with denudation of its epithelial coat. Other causes are improper handling of the genitals by the child's attendant, attrition of the penis against the clothing, and localized irritation of the parts such as exists in eczema of the genitals and of the foreskin, concealed chaneroids, and the initial lesion or other manifestations of syphilis. Among older children masturbation perhaps plays some part, but it is not by any means clear to my mind whether the masturbation, which both infants and children affected with a superficial balano-posthitis often practise, may not have been induced by irritation from the disease rather than that the balano-posthitis was produced by the masturbation. Besides these causes, rectal irritation from the presence of ascarides is supposed to induce irritation of the foreskin and external genitals, especially in grown-up children, and in some instances cretaceous deposits beneath the foreskin.

**Course.**—The course of a simple balano-posthitis is usually of short duration, provided the parts be kept clean and dry. The surgeon should seek as early as possible to find out the cause of the balano-posthitis, whether it is due to local or more distant and remote irritation, such as the presence of intestinal worms or self-abuse. In all of these cases the removal of the cause produces a rapid cure.

**Treatment.**—The treatment of this affection is in the majority of cases simple, and consists in keeping the parts scrupulously clean and dry. In children, where the foreskin is much swollen, red, and œdematous, frequent douching of the genitals with hot water and painting the external surface of the prepuce with a weak solution of nitrate of silver (from five to ten grains to the ounce), together with subpreputial injections of warm astringent solutions, will be found most effective. As soon as the foreskin can be retracted, concealed ulcerations should be looked for, and if they be of simple character, these also should be touched with a mild solution of nitrate of silver. If these ulcerations, however, are found to be chaneroidal, or due to the presence of an initial lesion, the treatment will be different from that which would be instituted in cases of balanitis from simple causes. The chaneroid should be thoroughly destroyed as rapidly as possible with some caustic, such as nitric, carbolic, or sulphuric acid, and the parts dressed with iodoform in combination with some inert powder, such as lycopodium, bismuth, or finely-powdered starch. The initial lesion should never be cauterized, provided it be unattended with inflammation, but had best be treated with powdered calomel, either alone or in combination with some of the above-mentioned powders.

The subsequent treatment in cases of simple balano-posthitis is to my mind better dry than wet,—that is to say, by the use of absorbent powders rather than by liquid applications. Wet dressings tend to macerate the parts, to cause a water-soaked condition of the mucous membrane, and to retard recovery. For that reason I seldom use the astringent solutions so often advised for that purpose, but dust the parts freely with iodoform mixed

in varying proportions with bismuth, tannin, calamine, powdered starch, and even calomel. Objection may be made to the odor of iodoform, but if the iodoform be mixed with finely-powdered coffee, either with or without charcoal, this objection will be obviated. The blackening effect of the charcoal may be diminished by the admixture of not more than ten per cent. of charcoal to the other ingredients.<sup>1</sup> Before making the dry applications, or even during their use, if the mucous membrane be still much irritated and inflamed, occasional applications of a five- to ten-grain solution of nitrate of silver will be found of much service. If the parts be well dusted, lint or absorbent cotton between the folds of the mucous membrane may be dispensed with, and in my opinion with advantage, as they tend to heat and oftentimes irritate the parts. As soon as the acute inflammation subsides, circumcision should be performed, unless contra-indicated by the presence of chancreoids.

**PHLEGMONOUS BALANO-POSTHITIS** is not a common affection, but it sometimes occurs as the result of a high degree of inflammation, and is not infrequently associated with the variety I have just described.

**Symptoms.**—The first symptoms are similar to those of the catarrhal variety, except that the redness, swelling, and pain are much intensified. Later in the course of the disease, one, very rarely two or more, small, hard points of thickening are felt in the foreskin, and the skin surrounding them becomes almost erysipelatous in hue. As the inflammation extends, the pain oftentimes becomes severe, the phimosis complete, and micturition painful. This condition of affairs may go on until the abscess is opened or until gangrene is induced from interference with the natural nutrition of the part. All movements of the body and pressure of the clothes, both of the body and of the bed, induce exquisite pain.

**Causes.**—The causes of this variety of balanoposthitis are partly local and partly general. The catarrhal variety may become phlegmonous, if irritated by masturbation, by injuries, by too severe cauterization in the process of treatment, or by improper and violent attempts to retract the swollen foreskin. A concomitant acute urethritis will oftentimes induce phlegmonous balanoposthitis, and in those cases the phlegmonous inflammation of the part may not only extend to the foreskin but may also invade the sheath of the penis, and even attack the scrotum. The same is true of concealed chancreoids beneath the foreskin; but the initial lesion, on the other hand, seldom gives rise to any acute inflammatory disturbance of this nature. The course of this variety is longer than that of the simple inflammatory type, usually lasting for several weeks, until the abscess either breaks or is opened artificially.

**Treatment.**—The treatment varies according to the cause. If due to

---

<sup>1</sup> A new chemical, called aristol, said to be a di-thymol di-iodide, and to contain a large percentage of iodine, promises to supplant iodoform in the treatment of diseases where this drug has been used, being, it is claimed, free from the pungent smell so characteristic of iodoform.

simple abscess, the attempt should be made to abort it by local fomentations in hot water, subpreputial injections, as advised for the simple type, and inunction to the swollen parts of belladonna and mercurial ointments. If such measures fail to produce the desired effect in a few days, and it is evident that the disease is going on to the formation of pus, as soon as the slightest fluctuation can be detected the abscess should be opened, cleansed, and weak solutions of nitrate of silver applied to the wound. The subsequent dressings should consist of the powders already mentioned, when the parts usually will heal rapidly and the concomitant inflammation will subside. If, however, these abscesses are due to the presence of concealed chancroids, the abortive method very seldom succeeds, the disease goes on to suppuration, and the resulting wound becomes chancroidal, either from absorption of or direct contamination by the chancroidal matter. In these instances, incisions should be made as soon as fluctuation is detected, the cavity of the abscess cauterized, and the wound treated as though it were a chancroid, which in reality it is. If the abscess threatens to produce a complete phimosis, and if micturition be seriously interfered with, the prepuce should be laid open by the bilateral method of incision, which will permit of free retraction of the foreskin, and the parts dressed as above advised. As soon as possible the resulting dog's-ears should be removed by the operation for circumcision.

**CROUPOUS BALANO-POSTHITIS** in children is a very rare affection. It is characterized by the presence of a whitish, membranous exudation which spreads over the glans penis from the fossa glandis, and sometimes over the inner layer of the prepuce. It is quite superficial, and is attended with but a slight amount of inflammation, and very little, if any, discharge. There is no constitutional disturbance, and the disease seems to be purely localized, yielding readily to treatment, especially to the application of lime-water, either in the form of subpreputial injections or as local dressings. This is one of the few instances in which wet applications answer better than the dry dressings which I have advocated for the more acute inflammatory types. The membrane becomes shrivelled, peels off, and leaves but a slight amount of redness and irritation behind it, and is not attended by local ulcerations or constitutional disturbance.

**DIPHTHERITIC BALANO-POSTHITIS** is less commonly seen than the preceding variety.

**Symptoms.**—The symptoms of this variety consist of a swelling of the prepuce, upon which circular or irregular patches of a dirty-gray membrane are seated. These usually occur on the inner lamella of the foreskin, sometimes upon the fossa glandis, and rarely on the glans penis. These patches which extend upon the surface frequently coalesce and are irregular in shape. They cannot be detached, being closely adherent to the mucous membrane, and their outlines are lost in the adjacent necrosing tissues. Sometimes the diphtheritic layer is seated on a wound of the foreskin, and when the bottom of the wound is covered with this membrane the neigh-

boring parts are inflamed and the penis thickened and swollen. Handling excites bleeding of the parts covered with this exudation.

If the course of the disease be towards an unfavorable issue, the swelling of the foreskin increases and the exudation extends over both the inner and the outer layer of the foreskin.

In these diphtheritic cases the concomitant symptoms are much more severe than in the catarrhal or the croupous variety. Thus, erysipelatous swelling of the penis or scrotum, enlargement of the inguinal glands, difficulty in micturition which may go on to retention of urine, and fever, not infrequently occur.

**Causes.**—The causes of this variety of balanoposthitis are both local and constitutional, but the latter are much more frequently the source of the disease. One of the most frequent of the local causes arises from decomposed smegma or the operation of circumcision, but even then it is extremely doubtful if diphtheria would supervene unless it was dependent upon a constitutional origin, and the so-called scrofulous diathesis is the most usual. It may also follow an attack of scarlet fever, small-pox, or measles. Some low forms of disease in the mother, especially those of an infectious puerperal nature, are said to be a cause of this disease in the child.

**Course.**—The course of this disease depends upon whether it be due to a local or a constitutional origin. If the former, it is usually rapidly cured, for the diphtheritic patches are, as a rule, small, circumscribed, and are exfoliated, leaving a very superficial ulceration behind, which heals quickly. If due to constitutional causes, the course of the disease is usually a grave one. When the membrane is cast off the resulting ulceration is generally deep, and is again oftentimes covered with a new membrane, causing the necrosis of tissues to extend and even threatening gangrene in its course. Severe deformities may result.

**Treatment.**—The treatment is twofold,—local and constitutional. The former is most efficacious when the disease is light, the latter when it is severe, although in neither case can constitutional treatment be entirely overlooked. The best local applications in mild cases of the disease are of lime-water, weak solutions of the bichloride of mercury, and dilute carbolized lotions; for the severe cases, washes of the mineral acids, nitric or nitromuriatic or sulphuric acid in the proportion of from a half to a full drachm to the pint of water. I do not think well of the application of nitrate of silver, except in mild cases, and then only as a stimulant after the membrane has been shed. Of course, in all cases the most scrupulous cleanliness must be observed. If phimosis be present, subpreputial injections of the mild solutions above mentioned should be used, but in cases where the disease threatens to extend, or where serious destruction is imminent, the foreskin should be split bilaterally, even though the edges of the wound are certain to become covered with the diphtheritic membrane. After the operation the wound and the diphtheritic portions of the genitals should be dressed with the acid solutions above described. When the ulcer cleans and the



diphtheritic layer has been cast off, powders of tannin, iodoform, or sulphate of zinc, mixed with some inert preparation, such as bismuth, charcoal, or starch, should be used. If the ulcerations become indolent or are covered with flabby, exuberant granulations, they may best be stimulated by weak applications of nitrate of silver, five to twenty grains to the ounce. The constitutional treatment must be of a supporting and tonic character, and should include the various preparations of bark, wine, iron, the mineral acids, and cod-liver oil, either iodized or ferrated.

**GANGRENOUS BALANO-POSTHITIS** is, strictly speaking, a variety of the other kinds, more commonly of the phlegmonous or the diphtheritic, and is due principally to an interference with the nutrition of the part.

**Symptoms.**—In the course of a phlegmonous balanitis where the inflammation is very acute, one or more points of a purple hue appear. This discoloration gradually extends until the limit of the interference of circulation is reached. This necrosis of the tissues, in cases where phimosis is a complication, is attended with a discharge of ichorous and fetid pus, mixed with shreds of sloughing tissue; the skin covering the glans penis becomes thin, ulcerates, and the glans penis protrudes through the slough. In this variety the glans penis seldom participates in the gangrene. The sphacelus generally tends to self-limitation, unless it is consequent or attendant upon a diphtheritic balanitis, when it usually extends with the diphtheritic exudation.

Gangrene may also follow in the course of a paraphimosis, when the glans cannot be returned, or from neglect to cut the constricting ring of mucous membrane. In these cases serious deformity from sloughing of the glans penis may ensue. In other cases, as a rule, no deformity results.

**Causes.**—The causes, as I have already stated, are due generally to some impediment to the circulation, but they are sometimes consequent upon constitutional disturbances, such as serofulosis, scarlet fever, small-pox, or as the result of an injury. It has been stated that gangrenous balanitis may occur idiopathically.

**Course.**—The course of the disease depends upon its cause. If from disturbance of nutrition, as soon as this is relieved the gangrene may sometimes be checked. In phlegmonous inflammation it is sometimes extensive, but even in these cases its tendency is towards self-limitation. In diphtheritic cases it is much more serious, because the sphacelus spreads with the extension of the exudation and the gangrene often is deep and severe.

**Treatment.**—When paraphimosis is the cause of the disease an attempt at reduction should be made, either manually or by incision. As far as is possible the extent of the gangrene should be limited by the employment of all means which tend to restore the proper circulation of the parts, such as hot fomentations, warm local baths, poultices with charcoal, and painting the inflamed tissues with nitrate of silver or tincture of iodine. If the disease be associated with phimosis, it is well to split the prepuce, and this may be done with impunity, as there is no danger of the inoculation of the

wound. Subsequent circumcision should be practised after the disease has disappeared. Other local means, such as the subpreputial injections and local applications of lime-water, astringent solutions, carbolyzed washes, iodoform, or charcoal powders, may be used, together with the internal administration of tonic and roborant medicines.

EXANTHEMATOUS BALANITIS is due to injuries, either accidental or self-inflicted, which induce erysipelatos swelling and inflammation of the parts.

**Course.**—Its course is usually rapid: the erysipelas spreads, and, if extensive, may become dangerous by inducing constitutional disturbances. As a rule, there is very little discharge with this form of balanitis.

**Treatment.**—The local treatment in such cases is to check as speedily as possible the spread of the erysipelas with iodine or nitrate of silver applications. Subsequently hot fomentations or lead and opium lotions may be used. The internal treatment should be by the administration of iron in large doses, quinine, the mineral acids, cod-liver oil, and wine, or other stimulants.

#### URETHRITIS.

Urethritis may occur in children and infants of all ages, and is divisible into two groups,—viz., those which are due to infection from impure contact and those which are due to non-venereal causes. In young infants the first variety is not common, but it is not at all rare among boys at or about the age of puberty. It may be divided into the three varieties of catarrhal urethritis, croupous urethritis, and urethritis of the external orifice or at the meatus.

CATARRHAL URETHRITIS commences with a sensation of tickling and pain during micturition, which speedily becomes quite severe and leads to a desire to pass water frequently. In the earlier stages it is associated with a thin mucous or muco-serous discharge, which rapidly becomes purulent and abundant. In cases where phimosis is present, the discharge produces irritation and inflammation of the mucous membrane of the foreskin and of the glans penis, and may lead to an attack of balanitis, which tends to obscure the true nature of the disease. The disease, at first situated in the anterior portion of the canal, rapidly invades the deeper parts and extends to the prostate gland and the neck of the bladder, producing prostatitis and cystic inflammation, precisely as it may in the case of adults. Epididymitis is also one of the complications which occur with this variety of disease. The urethral mucous membrane is red and swollen and evinces all the symptoms of an acute inflammation. In other words, it is a clap.

The variety of catarrhal urethritis which occurs in infants if due to improper attempts upon the child, runs the same course as it does in cases where impure coitus has been practised. But it must be remembered that all cases of urethral discharge in infants, even when catarrhal, do not necessarily mean impure or improper attempts upon the child's chastity. Intestinal worms, stone in the bladder, a tight and adherent foreskin, and,

it is said, masturbation, may induce urethral discharges which closely simulate a clap.

**Course.**—The course of this variety of urethritis is usually a favorable one, generally disappearing in two or three weeks' time, although it may, in rare instances, last longer. In infants it is not generally attended with any complications of the genito-urinary apparatus, although in boys it may be followed during the later stages by epididymitis or cystitis. Very rarely indeed is stricture the result of a urethritis in children.

**Causes.**—The causes which induce this disease have already been stated as due either to venereal contact or to masturbation. In addition to these it has been stated in the case of infants to occur idiopathically after vaccination, as well as from local irritation caused by the attrition of the clothing, by the use of catheters, and by the passage in the urine of gravel or small concretions of urinary salts. It has been believed that balanitis may induce a urethritis, but upon this point I am by no means convinced. It has also been asserted that exanthematous affections of the genitals, in which there is much itching and scratching of the parts, may give rise to urethritis.

**Treatment.**—The treatment of urethritis during the acute stage, when micturition is difficult and painful, when the mucous membrane is highly irritated and inflamed, and before the discharge has fairly commenced, is both local and internal. The local treatment consists of warm fomentations to the part, frequently repeated, to relieve the inflammation, but not poultices, and the application of cold compresses. Internally the administration of a few drops of the balsam of copaiba, the yellow oil of sandalwood administered in milk, or some mucilaginous or syrupy compound will be found, I think, of more service than the use of alkaline mixtures or the various remedies which are employed with the idea of neutralizing the acidity of the urine.

When the acute symptoms have passed away, mild astringent injections may be used, such as zinc, either the sulphate or acetate, alum, tannin, or red wine. With regard to the treatment of the complications, the only one which comes within the province of this paper is the affection of the testis, which has already been considered under the proper head.

THE CROUPOUS VARIETY OF URETHRITIS is an exceedingly rare affection, and one which I have never seen. It is described by Stiebel in "Das Lehrbuch der pathologischen Anatomie," III. Auflage, III. Band, 1861, and Pitha, "Ueber Krankheiten der männlichen Genitalien und der Blase."

It begins with urinary disturbances, retention, and pain in the region of the bladder which extends up as far as the kidneys. The urine, when passed, comes away in drops. The disease is attended in some cases with fever, a small, frequent, hard pulse, dry tongue, constipation, and with pain about the meatus. After the application of leeches, warm baths, and other antiphlogistic remedies, long cylindrical-shaped mucous casts are passed from the urethra, followed by a copious flow of urine, after which recovery

takes place rapidly. This usually happens about the third or fourth day of the attack. What the causes of this variety are I do not myself know, nor have I seen it stated in any work to which I have access.

URETHRITIS OF THE EXTERNAL ORIFICE is confined generally to the meatus and the first half-inch of the urethra, and is characterized by swelling of the glans penis near the urethral orifice, eversion of the mucous membrane at the meatus, and the appearance of grayish or yellowish-gray exudations scattered about the mucous membrane of the anterior half-inch of the urethra. These patches bleed readily upon being handled. The appearance of some of these patches is exceedingly suggestive of superficial chancroids or of mucous patches, for which they may readily be mistaken, but they are not inclined to extend nor to produce ulceration. After these patches of exudation have been cast off, the mucous membrane beneath is found to be intact, and the only result of this variety of urethritis is a contraction of the meatus.

**Symptoms.**—The symptoms complained of are severe smarting in micturition, which is sometimes so sharp as to prevent the child from emptying its bladder during one micturition. Sometimes the disturbance is severe enough to cause the child to cry out during micturition, which is only done as a last resort and when the bladder has become too full to hold any more urine. Sometimes the micturition induces a slight bleeding from the surfaces of the inflamed mucous membrane. There is usually no purulent discharge with this variety of disease, but the slight secretion from the surface of the patches of exudation sometimes dries and produces temporary closure of the meatus, which is forcibly and painfully separated during the first flow of the urine. As the disease goes on to recovery, micturition becomes impeded by the narrowing of the meatus, which is very readily overcome by a slight incision of the part. During the entire attack there is very seldom any fever or febrile disturbance, and the only other symptom besides the difficulty in micturition is a slight pain over the region of the bladder, from distention of the viscus.

**Course.**—The course of this disease is nearly always slow and chronic, often lasting for months. Sometimes, but very rarely, it may get well in a few weeks. The inflammation remains stationary and is not attended by any complications. In the majority of cases, as already stated, it ends with the contraction of the meatus, and this orifice loses its usual fissured shape, becomes round and narrow, and imparts to the finger the sensation as though there were a piece of stiff parchment beneath the surface of the mucous membrane. The meatus is sometimes so small that the urine comes out in a thin stream and obliges the child to take a long time to empty its bladder.

**Causes.**—The causes which induce this peculiar condition of affairs do not seem to be clearly understood. It occurs particularly in boys with a short prepuce or in those in whom the prepuce is naturally retracted. The cases which have been observed have all occurred in Jews, and it is believed that circumcision plays a part in its production, or, at any rate, that this

operation acts as a predisposing cause towards the disease. It usually occurs within the first seven years of extra-uterine life, and is very probably fostered by lack of cleanliness, dirt, mechanical irritation of the anterior portion of the canal, and inflammation from chemical causes due to changes of the urine in renal and vesical disease, as well as scrofulosis, rachitis, anæmia, and defective nutrition.

**Treatment.**—In cases where constitutional disturbances exist, attention should, of course, be paid to tonic methods of treatment, and, in addition to this, local means should be employed in the shape of frequent ablutions of warm water, strict cleanliness, touching the exudations with a weak solution of nitrate of silver, five grains to the ounce, and placing between the inflamed and swollen lips absorbent cotton soaked in astringent solutions, alum, sulphate of zinc, etc. Injections in these cases are of no use, and indeed can very seldom be employed, on account of the swollen and contracted condition of the part. For the resulting stenosis of the meatus an incision should be made, which can be kept open afterwards by dilatation with the small sounds used for dilating the meatus.

#### MASTURBATION.

Infants as well as children are unfortunately addicted to the practice of self-abuse, and in some instances to a marked degree. The symptoms in infants for which the surgeon is consulted are usually those of a nervous type, consisting either in convulsions during sleep, or else, if the child be more fully grown, of constitutional disturbances in the shape of loss of appetite, debility, and mental hebetude. In infants this habit is often practised during sleep by the little patient crossing his legs over his genitals so as to include them between the thighs and by long-continued friction to induce a species of orgasm, which is followed by clonic spasms, sometimes amounting to opisthotonus, a purple congestion of the face, stertorous respiration, upturning of the eyes so that the whites only are visible, and sometimes foaming at the mouth. The surgeon is often put upon the right track by finding, during his examination, that the penis of the boy is in a state of violent erection. Of course the cause of the convulsions and the other symptoms are at once apparent.

In grown-up children the habit is induced either by the example of their companions or by the teaching of their body attendants, and the symptoms in these cases are somewhat obscure. The child is brought to the surgeon for debility and nervous symptoms, which may range from epileptiform convulsions to chorea, dysphagia, loss of flesh and strength, and mental hebetude, in some cases amounting to idiocy. This, of course, is only in cases where the habit has been frequently repeated and for a long time. The surgeon upon examination in these cases usually finds the penis inflamed and disproportioned in size to the boy's years and stature, and sometimes associated with an œdematous condition of the free border of the prepuce.

**Causes.**—One of the most common of all causes is a long and dirty foreskin, particularly if it be adherent to the glans penis. Besides this, stone in the bladder, constipation of the bowels, the presence of intestinal worms, and balanitis of a mild form are strong predisposing causes for the habit. In grown-up children the example of their playmates, the teachings of older companions, and the reading of indecent literature also operate as causes.

**Treatment.**—Where masturbation is due to phimosis the first step towards cure is circumcision, and this simple procedure not infrequently brings about complete recovery. If caused by stone in the bladder, an operation for its removal is the only thing that can be done in the way of treatment. Where due to constipation, the presence of worms, or a balanitis, the removal of these causes is sufficient to effect a cure; but it sometimes happens that in spite of all treatment the boy persists in his habit. The most effective way perhaps of breaking it up is to blister a small portion of the penis, taking care that the skin of the scrotum is not invaded, by painting a narrow ring around this organ with vesicating colloidion, so that if any attempt at friction be made the pain obliges the infant or child to desist, and by repeating this vesication the habit may frequently be broken up. If the child is old enough to appreciate the difference between right and wrong, he should be advised as to the dangers which result to his health from a continuance of the habit, and by appeals to his sense of decency and good behavior. This in the majority of cases will, with care and attention on the part of his parents or those in authority, gradually cause him to discontinue the habit. In some cases, however, no means, physical or moral, seem to be of the slightest use, and it is usually in cases associated with some organic defect of the nervous system, either in the shape of epilepsy or in that of gradual paresis inducing idiocy, that all attempts at cure seem to be hopeless. Fortunately, such cases are rare, and it may be said perhaps in consolation that, unless associated with some congenital nervous disorder, patients outgrow the habit and suffer no evil consequences from their foolish indulgence in self-abuse. The reported cases of urethritis and urethral stricture induced by masturbation I regard with profound scepticism.

# DISEASES OF THE UTERUS, VAGINA, AND VULVA.

BY JOHN M. KEATING, M.D.

---

THE external genitals of the female child differ in appearance from those of the adult female principally in the prominence of the labia and the absence of pubic hair. "The large and the minute glands are less active functionally than in mature life, and the entrance to the vagina is less conspicuous and is more or less obscured by the hymen. As Leishman remarks, the conformation suggests the greater importance of the urinary as compared with the genital organs during the developmental period of the body. But it also means that the external genitals, with increased susceptibility to infection during childhood, are more exposed should opportunity for infection arise."<sup>1</sup>

A brief description of the anatomy of the female genital tract and external genitals is necessary before considering the affections of these parts. Such knowledge, besides insuring greater accuracy in diagnosis and more thoroughness in treatment, is especially important in view of the fact that disease occurring during the developmental period is frequently the cause of structural alterations and functional disorders found at maturity.

From a medico-legal stand-point the subject of which this article treats is of the greatest importance. It is undoubtedly a fact that the diseases of the genitals of young girls are not so carefully investigated by the physician as they should be; the result is that the diagnosis is frequently based upon the statement of the mother instead of upon a careful inspection, and to her is intrusted the treatment. A thorough examination should be made of every case, and the mother or care-taker instructed practically in the methods of local treatment.

## ANATOMY.

**Uterus.**—I quote from the article on Anatomy, in the first volume of this work: "Until the approach of puberty this organ exists as an undeveloped rudimentary body placed between the bladder and the rectum in the upper part of the pelvis (see Fig. 29). In the child it is wholly

---

<sup>1</sup> A. F. Currier, Medical News, July 6, 1889.

unlike what it becomes in the adult, not only in size, but also in its external and internal configuration. The cervix is longer, thicker, and firmer than that of the body. In truth, there can hardly be said to be any body to the organ in early life, for the arbor vitæ reaches to the top of the uterus, and there is no internal os. The upper portion is generally thinner and more flexible, and may be considered as representing the body. About the time of puberty the uterus undergoes rapid changes and acquires its adult character, the body growing faster than the cervix, together with the development of its appendages. The histology and physiology of this organ have been laboriously studied by numerous investigators, and the result of their views inclines to the belief that the uterus is normally anteflexed."

In adolescence, the mucous membrane of the body of the uterus is thin, composed of ciliated columnar epithelium on a delicate basement-membrane, and presents a punctated appearance, owing to the numerous openings of the glandular follicles which are scattered over its surface; these follicles are lined with non-ciliated, cuboid epithelium. The mucous membrane of the neck is much thicker, and is covered with squamous epithelium, the lower portion of which is furnished with villi; the glands at this part resemble those of the body, secreting a clear, tenacious substance. The Nabothian follicles are probably over-distended glands, having a cyst-like appearance, within the mucous membrane.

The arterics of the uterus are derived from the uterine artery, a small branch of the epigastric. The veins empty into the uterine plexus, a portion of the blood going to the ovarian veins. The nerves are derived from the inferior hypogastric and spermatic plexuses, and from the third and fourth sacral nerves. The lymphatics run to the pelvic and lumbar glands.

Continuity and contiguity of structure play an important part in the progress of the diseases which have leucorrhœa as a symptom.

The Fallopian tubes or oviducts, measuring about four inches in length, are lined internally with ciliated columnar epithelium, which extends even to the outer or peritoneal surface; in the interstitial portion, or that within the cornu of the uterus, the mucous membrane is entirely smooth, the opening of the tube at this point being very narrow.

**Vagina.**—The vagina is a tube composed of muscular tissue and mucous membrane, slightly curved from before backward, narrowed below where it joins the vulva, and receiving the cervix uteri at its upper part. Its usual length is two and a half inches in the adult, but it can readily be stretched to twice that length; the walls, as a rule, are in apposition. What are understood as the vaginal columns are two elevations of the mucous membrane, seen anteriorly and posteriorly. Folds or rugæ may be noted running transversely to the longitudinal ridges. (Fig. 1.) These are especially prominent on the anterior surface towards the external outlet. The anterior wall of the vagina is in the vesico-vaginal septum, the posterior in the recto-vaginal septum. By far the most important structure for



us to study is the mucous membrane. It has squamous epithelium, which covers large papillæ; the glands of Luschka, racemose glands, are situated

FIG. 1.

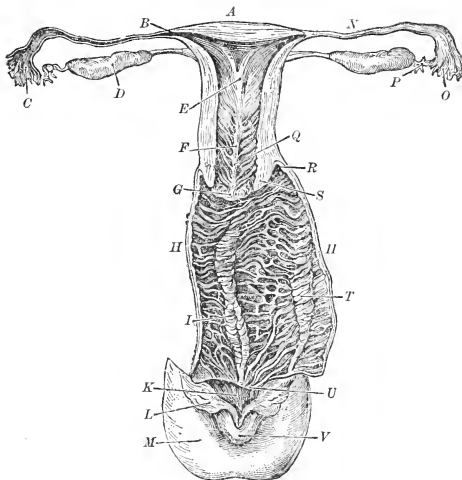

A, uterus; B, ostium tubæ uterinæ; C, ostium tubæ abdominalis; D, ovarium; E, cavum uteri; F, canalis cervicis; G, orificium vaginale; H, vagina; I, columna plicatus posterior; K, vestibulum; L, labia minora; M, labia majora; N, oviductus; O, fimbriæ; P, fimbria ovarii; Q, arbor vitæ; R, fornix; S, portio vaginalis uteri; T, columna plicatus anterior; U, hymen; V, præputium clitoridis. (From C. Heltzmann.)

at both extremities; throughout the rest of the tube the glands are of little importance.<sup>1</sup>

**Vulva.**—In this term are included the mons veneris, the labia majora and labia minora, the clitoris, and the glands of Bartholini or vulvo-vaginal glands. These glands are two in number, rounded or reniform in outline, racemose in character, and yellowish red in color. They lie between the cellular tissue of the vaginal wall and the constrictor muscle of the vagina, behind the lower part of the spongy body. The duct passes forward to open between the nymphæ and the hymen or its remains, its orifices being situated in the fossa navicularis, the space between the commissure and the fourchette. These glands, being for lubrication, are less developed in early childhood. (Fig. 2.)

The mucous membrane of the vulva is covered with squamous epithelium, and is pink in color. Around the nymphæ and urethral orifice are numerous simple racemose gland-follicles. The sensitiveness of the mucous membrane is increased by well-developed papillæ, which are extremely abundant in this position. Sebaceous glands are found at the junction of the

<sup>1</sup> Keating, Reference Hand-Book of the Medical Sciences, art. "Leucorrhœa."

skin and mucous membrane, at the free end of the clitoris, and on the labia majora. The lymphatics of the vulva are continuous with the internal iliac and the inguinal glands. This close relationship is well illustrated in the simultaneous pathological involvement of the lymphatics of the extremities or of the pelvic organs and those of the vagina.

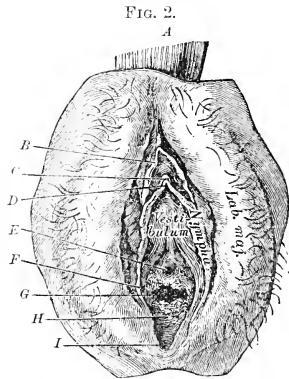

A, vagina; B, præputium clitoridis; C, clitoris; D, frænum clitoridis; E, orificium urethrae; F, orificium glandæ Bartholini; G, ostium vaginae; H, hymen fimbriatus; I, fossa navicularis. (From C. Heitzmann.)

The blood-supply is derived from the internal pudic artery, the more superficial parts being supplied by branches from the external pudic. The venous circulation is maintained through the vaginal plexus, which empties into the obturator veins. The superficial veins empty into the external pudic and into the femoral. The nerves are branches of the ilio-inguinal and genito-crural of the lumbar plexus.

**Hymen.**—The description of the hymen given by Dr. Henry C. Coe<sup>1</sup> is as clear as any I know of, and the following is taken from it :

“The hymen is a circular or crescentic fold of connective tissue, covered by mucous membrane, which immediately surrounds the orifice of the vagina and forms the lower extremity of that tube. The hymen is almost invariably spoken of as a ‘fold of mucous membrane’ which partially closes the orifice. Budin proved conclusively that it is anatomically a folding in the entire vaginal wall.”<sup>2</sup>

Pozzi<sup>3</sup> believes that it is an outgrowth from the foetal sinus urogenitalis, and hence that it is really a part of the vulva. He regards the hymen as the analogue of the bulb of the urethra in the male. To quote further from Dr. Coe, “The hymen ordinarily appears as a crescentic fold situated at the posterior part of the introitus. It lies loosely against the posterior vaginal wall ‘like a jib bellied by the wind,’<sup>4</sup> and does not assume the appearance of a tense membrane stretched across the orifice unless the thighs are widely abducted so as to separate the sides of the canal. So little obstruction does this variety of hymen offer to the introduction of a foreign body into the vagina that it frequently persists after repeated acts of coitus.” This author,

<sup>1</sup> American System of Gynæcology, vol. i. p. 117.

<sup>2</sup> Progrès Médical, Aug., 1879, p. 677; also Ledru, Thèse de Paris, 1855. Dr. Mathews Duncan has seen the hymen present when vagina and uterus were both absent. On these grounds he regarded the view of M. Budin (that the hymen is nothing but the anterior extremity of the vagina) as incorrect.—*Lancet*, Oct. 28, 1882.

<sup>3</sup> Gazette Médicale de Paris, February 23, 1886, p. 86.

<sup>4</sup> American Journal of Obstetrics, January, 1880, vol. xiii.

after again quoting Budin<sup>1</sup> as stating that in a single year he had found the hymen intact in no less than seventy-five primiparæ who were examined during labor, says, "It is unnecessary to refer to the medico-legal importance of this structure, since it is an accepted fact that neither is its presence an absolute proof of chastity in its possessor, nor, on the other hand, does its rupture imply that sexual intercourse has taken place."

The hymen is not a thin fold of mucous membrane, as it was formerly believed to be, but it is the lower end of the vagina, and consequently has a variety of shapes. This is readily shown by a section of the vagina in which the external outlet can be seen from within. (Fig. 3.)

I quote from Garrigue,<sup>2</sup> as follows :

Tardieu, who has examined more than six hundred cases with special reference to the hymen, admits five normal conformations, which he places in the following order of decreasing frequency :

1. The hymen consists of a strip of tissue bent at the lower end so as to form two lateral lips, touching one another in a vertical line; which shape is almost constantly found in childhood and sometimes after puberty.<sup>3</sup>

2. The hymen forms an irregularly circular diaphragm, with a more or less large opening in the anterior third (*hymen annularis*).

3. The diaphragm is exactly circular, with a central circular opening (*hymen circularis*).

4. The diaphragm is crescent-shaped, with a concave border turned forward, and two horns ending on the inside of the labia minora (*hymen semilunaris*).

5. The hymen is only represented by a low circular or semilunar edge. This is often overlooked and mistaken for total absence of the hymen, a condition which probably does not exist.

The first successful coitus does not destroy the hymen:<sup>4</sup> it is simply torn, and the flaps can be at once readily approximated and the integrity of the hymen apparently restored. Over-distention (Schroeder) of the vagina by parturition and subsequent involution actually destroy the hymen.

According to Dr. Mundé, physiological lacerations of the hymen are on each side of the posterior commissure, the rent on one side being usually deeper than that on the other. Next in frequency are two rents on one side, one above and one below, and possibly one rent on each side near the upper

FIG. 3.

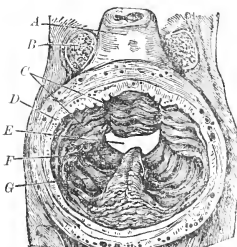

A, urethra; B, corpora cavernosa clitoridis; C, columna plicatus anterior; D, membrana mucosa; E, ostium vaginæ; F, hymen semilunaris; G, columna plicatus posterior. (From C. Heitzmann.)

<sup>1</sup> Des Lésions traumatiques chez la Femme, etc., 1878.

<sup>2</sup> American System of Gynæcology, vol. i. p. 262.

<sup>3</sup> Courty, Diseases of the Uterus, Ovaries, and Fallopian Tubes.

<sup>4</sup> Mundé, American Journal of Obstetrics, October, 1889, p. 1022.

border of the membrane. The character of these rents after forcible stretching is such that they are apt to unite upon re-occupation of the parts.

Atresia of the lower end of the vagina is a well-known cause of hæmorrhoids, hæmatometra, and hæmatosalpinx. Dr. Field<sup>1</sup> has tabulated sixty-five cases of atresia with hæmatosalpinx. In opening the vaginal canal in such cases simple incision will not be satisfactory: according to Dr. Field a circular piece of the vaginal wall should be removed. Of the sixty-five cases first alluded to thirty-four died; thirty-nine of these fatal cases had been operated upon. I mention this subject here simply to draw the great importance of careful investigation of all cases of delayed menstruation, and also to call attention to the fact that obstruction to a menstrual flow will finally induce uterine hypertrophy and distention of the tubes.

The hymen may exhibit various peculiarities which should be known. The hymen in the fetus has a serrated instead of a smooth edge; the *hymen* *adulescens* shows a fringed appearance. Then, again, the opening into the vagina may have certain abnormalities. There may be two openings, with an intervening septum. If these openings are round or lengthy and large, it is called a *hymen bifidus* or *diplacatus*; if the septum is large and the openings are small it is called a *hymen septus*. When its partition does not unite in the middle but grows from the anterior and posterior portions, it is called a *hymen bipartitus*. When perforated, it is a *hymen evirginiformis*.

I have dwelt at length upon the anatomy of these parts because I am convinced by my reading and experience that sufficient attention has not been paid to the consideration of the affections of the mucous membrane of the genital tract in young females. The catarrhs of infancy—which, as we shall see, may result from cold, pent-up secretions, want of cleanliness, etc.—act upon the mucous lining of the uterus and tubes as they do upon that of the nasal chamber, producing congestion, infiltration, and finally stenosis of the passages. The effect this has upon the uterus is to congest it, to structure, and, to increase its weight; and undoubtedly the uterine catarrhs and vermin, with their many symptoms, including dysmenorrhœa, that attend on early child-bearing, owe their origin to this cause. "Either vulvitis or vaginitis may exist alone, but more frequently the infectious disease which begins with the vulva does not end there. In adults this disease not infrequently extends to the uterus, the Fallopian tubes, the ovaries, and the peritoneum and may, finally, . . . It seems extremely probable that many of the ill-used and undeveloped uteri with which are associated so much immaturity and anæmic sterility and domestic unhappiness, are the legitimate consequences of vulvo-vaginitis in early life."<sup>2</sup> If it were generally known by mothers that vulvo-vaginal catarrh is a serious matter and needs careful and early attention, many times would the family physi-

<sup>1</sup> *Annals of Gynæcology*.

<sup>2</sup> *Cancer Medical News*, July 3, 1889.



ing from the right side of the fundus, and another from the left side; the latter was softening. Deposits covered the anterior peritoneal surface of the bladder. The uterine mucous membrane, cervix, tubes, ovaries, and vagina were healthy, though under the microscope the tumor appeared in parts of sarcomatous character; in others it was truly cancerous. Eckhardt has noted a case where a large mass which filled the vagina sprang from the cervix of a girl aged nineteen. The growth was apparently rather a sarcoma than a cancer. Gaughofner, after noting the above cases, describes<sup>1</sup> a case where the cancer attacked the vaginal portion of the cervix of a girl aged eight. For two or three years blood kept escaping from the vagina. The growth was fungous and very brittle; it was confined to the anterior part of the cervix, and the vagina was quite free from disease. The tumor was carefully cut away, and its base ("of the size of a twenty-kreutzer piece") cauterized. Under the microscope it proved, according to Professor Chiari, to be a medullary glandular carcinoma. No secondary deposits were found, and no glands were enlarged.<sup>2</sup> Schnata described a case of malignant adenoma of the cervix in a girl aged sixteen; Glätter, in one of seventeen; and Eckhardt, in one of nineteen.<sup>3</sup> The exciting cause in these cases was not definitely determined. It has been noted that this malignant growth is, as a rule, more virulent in young than in older subjects. The treatment may be palliative, but general opinion inclines to the immediate removal of the tumor, if possible, though this is, of course, not permanently curative.

#### DISEASES OF THE VAGINA.

1. SIMPLE CATARRHAL VULVO-VAGINITIS.—This is an ordinary catarrh of the mucous membranes, and has all the characteristics that belong to catarrh elsewhere. It is extremely common among the poor and uncleanly, though by no means dependent alone upon dirt and irritation. It is a common accompaniment of malnutrition, and consequently is found usually in cachectic children of all ages. A slight leucorrhœa may be noticed in delicate children, and need not cause alarm, as it will yield readily to tonics and is only an evidence of anæmia. It may also be the forerunner of puberty, and will be found especially in girls of nervous temperament, rapid growth, and early development. There is excessive secretion from the muciparous glands, and also a transudation from the blood-vessels. It can be produced by any outside irritation, or may accompany the eruption of an eruptive fever, especially scarlet fever and variola. The discharge is colorless, and at times very irritating; indeed, often attention is first called to it by the excessive itching it produces. In children the itching causes the patient to rub the parts continuously, and either produces excoriation or leads to masturbation. Frequently, if there is want of cleanliness

<sup>1</sup> Zeitschrift für Heilkunde, 1888.

<sup>2</sup> British Medical Journal, January 5, 1889.

<sup>3</sup> Annual of the Universal Medical Sciences, Sajous.

or excessive local irritation, the discharge dries upon the surface, is mucopurulent, the parts become ulcerated, or crusts form which leave sores when disturbed.

The physician should make a very thorough examination, especially of the vulva, of these cases when brought to him. The introduction of foreign bodies will cause a vulvo-vaginitis, and attempts at rape, even when gonorrhœa can be eliminated, will produce a catarrh through traumatism.

**Treatment.**—In adolescence leucorrhœa prevails as an accompaniment of the rheumatic and gouty diatheses, during convalescence from various fevers, in pulmonary phthisis, and in local tuberculosis. The treatment, therefore, in all cases has to be either constitutional or local, and in most cases both. In the child as well as in the adult, if the leucorrhœa is indicative of a cervicitis,—that is, if it is composed of a glairy mucus with destroyed endothelial cells (the whites), accompanied by more or less irritation of the parts,—constitutional treatment is most important. Fresh air, generous diet, bathing, massage, iron, arsenic, quinine, cod-liver oil, bichloride of mercury (in minute doses), and red wine are indicated.

Constipation is extremely common in all cases that have leucorrhœa as a symptom. Careful inquiry will frequently prove this though the statement be made that the child has a movement every day: an accumulation of scybala will usually be revealed by a large enema. Attention to this matter should be the initial procedure in every case. Every evening the child should have, if needed, an enema of tepid water with a pinch of salt and a small quantity of olive oil; and each morning, before breakfast, a glass of pure spring water, or a half-teaspoonful of compound liquorice powder, or Tarrant's aperient, or elixir of cascara sagrada, or bitartrate of potassium. A glycerin suppository occasionally is useful. The child should have a morning bath and rapid sponging with salt water (a half-ounce to a gallon) and friction. The genitals should then be anointed with some substance that will not become rancid. My preference is for carbolated white vaseline, or white vaseline and lanoline and oxide of zinc ointment. After this the parts should be dusted with fine boric acid such as is used by aurists. This can be done with a powder-insufflator. If the mother cannot use this, vaginal suppositories can be inserted of iodoform, boric acid, subnitrate of bismuth, acetate of lead, or tannin. If the discharge is annoying, causing much pruritus and quite abundant, a small quantity of glycerole of tannin should be introduced into the vagina in suppository form with oleum theobromæ, and retained by a cotton pad.

The cases that require the treatment just indicated are those ordinarily known as "whites," the simplest form of mild catarrh. In very mild cases, and in older children, washes may be of service, provided they are made to enter the vagina. The simple washing of the external genitals with infusion of white-oak bark or alum-water is seldom of any service in any form of infantile leucorrhœa.

Of course in all these cases constitutional treatment should be instituted:

cod-liver oil, with syrup of hydriodic acid or syrup of iodide of iron, is especially indicated.

2. THE INFECTIOUS VARIETY OF VULVO-VAGINITIS.—Although I believe that most if not all of the cases of vulvo-vaginitis that present the characteristics which accompany this form are gonorrhœal or specific in their origin, I have adopted the title of *infectious*, so as to include the doubtful cases.

The presence of the gonococcus certainly is sufficient at the present day to carry with it a strong supposition of the gonorrhœal origin of the case. Spaeth<sup>1</sup> examined the discharges from twenty-one cases of vulvo-vaginitis in girls between three and eleven years of age, and found Neisser's coccus in fourteen. In none of these cases did the inflammatory process extend to the urethral mucous membrane, whereas in adult females the urethral discharge always contains cocci. The gonococcus may be detected after the method of Neisser. A drop of the secretion is pressed between cover-glasses, dried over a spirit-lamp, stained with methyl-blue, passed through oil of cloves, and mounted in Canada balsam. The gonococci are then readily recognized, even with a one-fourth-inch dry objective and a D eyepiece; for differential study a higher magnifying power is necessary.

The form of vulvo-vaginitis under consideration has its analogue in the ophthalmo-blennorrhœa neonatorum; its highly infectious character is demonstrated by the rapidity with which it attacks children in hospitals and asylums where the little inmates are neglected, where they are washed in the same tub, possibly with the same water, and where the soap and towel are common property. It is often found in children of filthy habits.

**Diagnosis.**—Possibly attention is not called to the case until it has progressed for some time. The labia are red and swollen, the mucous membrane resembling "wet hemlock sole-leather," the secretion being purulent, muco-purulent, or sanguino-purulent. The discharge has probably excoriated the parts in the vicinity, and has dried in crusts or in the creases. Undoubtedly most, if not all, of these cases are of gonorrhœal origin, and the mucous surfaces most affected are those external to the hymen, including the urethra. Severe urethritis is almost pathognomonic of gonorrhœa, though this is most common in the adult. Should the case have lasted for some time, or if it has been caused by sexual intercourse more or less complete, the inflammation will not be limited to the mucous membrane of the outlet, but will involve the vagina and the cervix and eventually produce a salpingitis. The representation of the mucous membrane in Fig. 2 shows how easily the infectious material can become located in the vaginal folds. In asylum cases, or in children of the poor and dirty, an infectious vulvo-vaginitis is liable to take the same course, and tubal or ovarian disease and even peritonitis may result.<sup>2</sup>

<sup>1</sup> München. Med. Wochenschrift, May 28, 1889; also an interesting editorial in the New York Medical Journal for July 13, 1889.

<sup>2</sup> Francis Huber, Archives of Pediatrics, December, 1889, p. 887.



**Treatment.**—In cases of long-standing leucorrhœa the treatment should consist in first etherizing the patient and making a thorough examination. The surface should be cleansed by irrigation throughout the vaginal tract, and in all cases where applications are required to the mucous membrane of the vagina and uterus they should be made above the line where the mucous membrane seems affected.

Having thoroughly washed out the cavity, the large blade of a Skene's urethral speculum should be used in the Sims position, care being taken not to tear the hymen, and whatever application is necessary should be made at once. The mucous membrane may be wiped over with absorbent cotton, and the vaginal surface then thoroughly coated with a strong solution of nitrate of silver, twenty to thirty grains to the ounce; or we may employ a solution of sulphate of copper, boric acid, carbolic acid, and glycerin, the parts being well greased with a stiff ointment, in order to keep the surfaces thoroughly lubricated and apart.

In cases of the infectious variety the mucous membrane should be thoroughly cauterized with the solid silver stick, or with a strong solution of nitrate of silver, or some of the other materials already mentioned, great care being taken that all diseased portions of the mucous membrane have been reached. If the disease has lasted some time, it will be found that the cervix is also affected, and before a cure can be brought about it will be necessary to make a similar application to this surface; neglect of this is probably the cause of so many cases of leucorrhœa or gonorrhœa existing after the treatment has been supposed to be most thorough. The mucous surfaces should then be kept apart by means of lint or cotton covered with oleaginous material, carbolized oil, or benzoated zinc ointment, and thoroughly irrigated—not merely syringed—with either a hot solution of corrosive chloride of mercury, in the proportion of one to five thousand, or calomel  $\mathfrak{v}$ i, listerine  $\mathfrak{z}$ i, aquæ calcis  $\mathfrak{z}$ v; or the following may be used, diluted to suit the case:

R Benzoic acid, gr. xxx;  
 Oil of wintergreen, gr. lx;  
 Oil of eucalyptus, gr. lx;  
 Thymol, gr. c;  
 Salicin, gr. xl;  
 Glycerin, f $\mathfrak{z}$  ii;  
 Water, f $\mathfrak{z}$  xxii;  
 Alcohol, f $\mathfrak{z}$  xl.  
 To make O iv.

Injections of red wine are also efficacious, and, if much pain exists, belladonna and opium may be added to the injection.

Should it be found that the disease involves the uterine canal, applications should be made to the entire endometrium, even as far up as the fundus if the internal os is patulous.

The character of the application should depend entirely upon the extent of the inflammation of the mucous membrane. Ordinary simple catarrh,

which is superficial, possibly may need only the mildest form of alterative and astringent applications, such as chlorate of potassium, ferric alum, tannin, and the abundant use of hot water to diminish local congestion. The hygroscopic property of glycerin renders it most valuable in relieving congestions of the mucosa. Tampons of cotton or wool impregnated with glycerin should be inserted into the vagina to support the uterus; and astringents, such as tannin, may be incorporated with the glycerin.

Thorough cleanliness should be insisted upon, and, after this has been attended to, the physician may select for himself the wash or application which he prefers. I will offer simply a few suggestions as to treatment, referring to the articles quoted for a more elaborate exposition.

J. B. Johnson,<sup>1</sup> after dwelling upon the highly irritating character of the discharge in vulvo-vaginitis and also the danger of infection, recommends the following:

R Acid. carbol., gr. x;  
Sodii bibor., ℥ii;  
Glycerini, ℥i;  
Aquæ, f℥v.  
Misc.

Shake well, and use four times daily, after the parts have been well washed.

In severe vaginitis he recommends balsam of copaiba, three or four drops, placed in the ostium vaginæ and allowed to remain there. If pure copaiba irritates, mix with equal quantities of cacao butter or carbolized vaseline and apply with a camel's-hair brush.

T. G. Thomas<sup>2</sup> advises that the vagina should be thoroughly cleansed and then a wash used of one ounce of "black wash" to a pint of water.

Ellis<sup>3</sup> advises a thorough washing with warm water, and then a weak astringent lotion of sulphate of zinc, alum, acetate of lead, boric acid, or nitrate of silver, according to the severity of the case. He advises cold salt-water baths with friction with a coarse towel, and change of air to the sea-shore, also ferruginous and bitter tonics.

It is well not to begin treatment with materials that will stain the clothing, but of course, should the discharge persist despite milder applications, nitrate of silver, tannin, etc., will have to be used. In severe cases of vulvo-vaginal catarrh in infants, as well as in older children, it is far better to make a thorough application at once to the mucous surfaces. For this purpose the child should be etherized, the parts well irrigated with warm water and bichloride (one to four thousand) or with creoline, the vagina opened carefully by means of a speculum of the Sims pattern (a bent pewter teaspoon handle serves well), and the whole canal packed with strips of iodoform lint. The orifice of the urethra should be painted with a solution of the nitrate of silver (ten or fifteen grains to the ounce). Iodoform

<sup>1</sup> Medical and Surgical Reporter, May 12, 1888.

<sup>2</sup> *Ibid.*, March 31, 1883.

<sup>3</sup> Diseases of Children.

should be sprinkled well on the mucous membrane of the external opening, and the whole vulva covered with a mass of borated absorbent cotton. This outer dressing should be removed when the child urinates, and a fresh one applied. In twenty-four hours the lint can be removed, and the parts well irrigated with Dobell's solution or a lotion of black wash and listerine. Dobell's solution has the following formula :

R Borate of sodium, grs. 120 ;  
 Bicarbonate of sodium, grs. 120 ;  
 Carbolic acid, crystallized, grs. 24 ;  
 Glycerin, ℥ $\frac{7}{8}$   $\frac{1}{2}$  ;  
 Water, enough to make ℥ $\frac{7}{8}$  16.

Dissolve the salts in about eight fluidounces of water, and add the glycerin and carbolic acid, previously liquefied by warming. Then add the water to make sixteen fluidounces, and lastly filter.

An application of a five-per-cent. solution of cocaine to the parts with a camel's-hair brush will allay pain and smarting and allow the child to permit of the thorough washing necessary.

Should there be the least suspicion of gonorrhœa, no time is to be lost. The vagina must be thoroughly dilated, and a solution of nitrate of silver applied to the whole surface, followed by a dressing consisting of thorough packing with cotton or lint smeared with the oleate of bismuth or the subnitrate of bismuth with glycerin (Currier).

3. PHLEGMONOUS VULVO-VAGINITIS is usually either due to traumatism or may accompany or follow the eruptive fevers. Possibly in children who are otherwise diseased, the irritation of a simple catarrhal vulvo-vaginitis may be productive of ulceration and gangrene. The infectious and phlegmonous types may be associated.

**Treatment.**—Thorough cleanliness should be enforced, and modern antiseptic measures instituted, preceded, if necessary, by surgical treatment. Frequently, should ulceration and gangrene set in, cauterization will be required. Tonics, stimulants, nourishment, and fresh air are imperatively indicated.

4. DIPHTHERITIC VULVO-VAGINITIS.—This is not confined to cases of diphtheria, but may accompany all septic diseases, including scarlet fever and measles. It is, of course, of very serious import to the life of the patient, and there is great danger of infecting others. It leads to gangrene and septicæmia.

**Treatment.**—Vulvar and vaginal diphtheria should be treated with the same thoroughness as diphtheria of the air-passages. A solution of salicylic acid has been recommended as a specific by some. A frequent application of peroxide of hydrogen has been advocated by many. The parts should be treated antiseptically, washed, and packed, so that the whole surface shall receive treatment. In diphtheria the complication is apt to be very fatal, as it shows the dyscrasia to be well marked, and the treatment, as far as supporting the system is concerned, must be heroic.

Cysts of the vagina constitute a form of tumor which occurs oftener than is usually supposed, though comparatively rare in the very young. Johnston<sup>1</sup> cites fifty-two cases in which the age of the patients had been noted, and among these five were between the ages of ten and twenty years, and one was under ten years. Neither heredity nor constitutional tendency is considered a predisposing cause, but rather disease or injuries which directly alter the tissue of the vaginal wall. Among the theories which have been advanced are the following:<sup>2</sup>

1. That they are the result of an accumulation of the secreted fluid in a depression formed by the union of the crests of two contiguous folds of mucous membrane.

2. That they are the result of simple dilatation of the lymph-channels which traverse the connective tissue of the vaginal wall.

3. That they owe their origin to the ducts of Gärtner.

4. That they owe their origin to the glands in the vaginal mucous membrane.

They occur as simple, compound, single, and in masses. Usually they appear singly. Their size varies from that of a pea up to that of a pear, though a size about midway between these extremes is oftenest met with. According to Winckel, their location is on the anterior or the posterior wall of the vagina, as a rule, and usually in the lower or the middle third, though Johnston states that they occur more often in the upper part. They are frequently accompanied by a leucorrhœal discharge and a mechanical interference with function. Pain and tenderness occur chiefly where inflammation and irritation exist. Occasionally marked nervous symptoms are present.

Several modes of treatment have been advised in the removal of these growths. Johnston, in the article referred to, inclines to Schroeder's operation if the cyst cannot be cured by puncture or incision. This consists in the removal by seissors of all that part of the growth that projects above the vaginal surface, and the union by sutures of the mucous membrane of the vagina to that which lines the tumor. Enucleation, though safe and advisable in small cysts, becomes dangerous in cysts of larger size.

FIBROMA.—This is a rare condition, yet its occurrence in early childhood has been reported.<sup>3</sup> The upper third is usually the region of the vagina which is affected. Its cause is obscure. It may be a congenital growth or it may be developed later, appearing generally about the age of puberty. The symptoms produced are very similar to those of a like condition of the uterus, including the bleeding and discharge. As a rule, removal of the growth, either by ligature or by the knife, is advised, unless contra-indicated by its position, vascularity, or some form of complication.

---

<sup>1</sup> American Journal of Obstetrics, November, 1887.

<sup>2</sup> Dr. J. M. Baldy, Philadelphia Medical and Surgical Reporter, February 15, 1890.

<sup>3</sup> Mann, Gross.

Generally a small tumor should not be disturbed by radical measures. Winckel advises recourse to surgical interference when the tumor has reached the size of a walnut, for then its disturbance of function and its tendency to cause displacement become matters of serious import.

SARCOMA is even more rare than fibroma, yet various cases of its occurrence in early youth are on record.<sup>1</sup> Dr. R. W. Taylor reports<sup>2</sup> cases of melano-sarcoma in adults, and refers to Köbner.<sup>3</sup> Schuchardt, in a paper read before the second congress of the German Gynecological Society, held at Halle in May, 1888, cites two cases. According to Schubert, of seven cases reported only one was noticed at birth, the ages of the other children ranging from two to five. The etiology of these growths is obscure. Any congenital lesion or any irritation of the parts may be a primary cause. Dr. Schuchardt believes that in the cases coming under his observation the tumors originated from certain papillary structures which normally exist in the region of the vagina. The treatment is removal as soon as possible. In the article referred to above, Dr. Taylor speaks favorably of the action of arsenic injected into the mass. According to statistics, this growth has proved very malignant, metastasis occurring through the vascular system, and after removal the formation being reproduced. The prognosis is then of necessity fatal, and relief of the suffering is all that can be looked for.

CARCINOMA, like sarcoma, is exceedingly rare. Mann cites two cases between fifteen and twenty years, and one case in early childhood. The cause of this formation is the same as that of sarcoma, heredity, however, having a strong influence. Metastasis occurs along the course of the lymph-vessels, and tendency to renewed growth after excision is the inevitable consequence, should the patient survive. Palliative treatment necessarily is to be adopted, and, if feasible, the growth removed as quickly as possible, and, as in all cases of growths or disease of these organs, the patient should be given nourishing food, plenty of fresh air, and tonics, so as to build up the general system.

Foreign bodies introduced into the vagina from without are not of infrequent occurrence, comparatively. They give rise to irritation, and if left long enough produce great pain and discomfort, even going on to ulceration. Removal of the cause and treatment of the parts involved constitute the method of procedure under such circumstances.

#### DISEASES OF THE VULVA.

PRURITUS VULVÆ.—This is an annoying and very frequent condition, depending in children upon various causes, which may be either local or constitutional, but usually are both. Almost all forms of leucorrhœa will

<sup>1</sup> British Medical Journal, September 6, 1888, and January 19, 1889.

<sup>2</sup> New York Medical Journal, July 6, 1889.

<sup>3</sup> Berlin. Klin. Wochenschr., No. 1, 1881.

produce irritation of the genitals. The causes may be classified as follows: (1) animal and vegetable parasites (ascarides being most common in young girls); (2) diseases of the vulva; (3) diseases of the urinary system (diabetes, etc.); (4) vaginitis; (5) diseases of the uterus; (6) ovarian and other tumors; (7) skin-affectations; (8) diseases of the nervous system.<sup>1</sup>

Where the history of pruritus vulvæ is presented, of course it is necessary to understand thoroughly the cause, in order to treat it intelligently. It is necessary to inquire into the history of the case and the constitutional tendency of the individual, and the family record should be investigated as to the question of tuberculosis. Careful search should be made for the existence of any parasitic affection, and inquiry instituted as to the presence of vesical and urethral disorders, diabetes, etc. The genital organs should be carefully examined for evidence of leucorrhœa, psoriasis, eczema, or any other local skin-affection.

The absence of pubic hair will preclude the possibility of pediculi, but scolices may find an entrance into the tender tissue of the groin and the neighboring parts.

**Treatment.**—In regard to treatment, it should be both constitutional and local, the constitutional treatment consisting of proper hygienic measures, assimilable nutriment, tonics, if necessary, and plenty of fresh air. The nervous system requires careful attention; in fact, it may be necessary to employ sedatives for a time, but the use of opium should be avoided. A careful study of local causes should be made, that proper treatment may be instituted. The use of local applications which are sedative to nerve-termini is indicated in all cases of neuropathic origin. Of these, painting with menthol, peppermint, and cocaine is of the greatest value; but when these applications are made, it should be remembered that their favorable action does not last long, and that constant reapplication to the sensory nerve-filaments in the papillary layer of the cutis is necessary. Routh<sup>2</sup> mentions urethral caruncle as a possible cause. This should be borne in mind, and proper treatment instituted, if necessary. In the pruritus from leucorrhœa of vaginitis he advises constant bathing of the part with a solution of—

R Borax, teaspoonful;  
Oil of peppermint, gtt. v;  
Water, hot, Oi.

Shake well, and bathe the parts freely with a soft sponge.

Julien's formula is an excellent local application:<sup>3</sup>

R Zinci oxidi, gr. xxv;  
Acidi salicylici, gr. i;  
Glycerini amyli, gr. xxv.  
Apply locally.

<sup>1</sup> Wiltshire, British Medical Journal, March 5, 1881.

<sup>2</sup> British Medical Journal, April 14, 1888.

<sup>3</sup> Journal of Venereal and Cutaneous Diseases, April, 1886.

Ascarides can usually be detected, and thorough washing, with an application afterwards of carbolized oil or vaseline or the use of enemata of olive oil and lime-water, will destroy them. Should the irritation remain, a lotion of black wash and vinum opii will be of service. When the itching is associated with much inflammation of the vulva, it is advisable to employ a demulcent wash, such as infusion of marshmallow, or to apply a poultice of linseed-meal or potato-starch with vinum opii or infusion of poppy-heads, until the inflammation shall have subsided.

For pruritus ani the following will be found beneficial :<sup>1</sup>

R Hydrarg. chlor. mit., ʒi;  
 Balsam. Peruv., ʒ iss;  
 Acidi carbolic, gr. xx;  
 Lanolin, ʒi.  
 Once or twice daily.

CONDYLOMATA.—It is not necessary to go into a detailed account of this affection, as it is treated of in all works on venereal diseases. It may be stated, however, that it is a very common form of cutaneous growth, which, as a rule, is located in the neighborhood of the anus and the genital organs, and is due to irritation produced by acrid vaginal or rectal discharges. According to Winckel, "sharp or acuminate condylomata arise from a multiplication of papillæ, but occur upon parts devoid of papillæ." They are of frequent occurrence on the labia, and in the vestibule, even extending over the thighs and upon the abdomen. They are usually quite small, but the size varies from that of a millet-seed to that of a walnut and even larger. "They are always pedunculated, generally flat, at first fringed or shaped like a cock's comb, and are much softer than papillomata." They are vascular, and liable to become painful and inflamed if subjected to friction, infecting healthy skin with which they come in contact.

There is some difference of opinion as to the definite cause of these structures,—whether it be gonorrhœal or syphilitic, or whether they may not be spontaneous growths. Fritsch reports cases of children under one year on whom were pointed condylomata where gonorrhœal infection was out of the question. Other instances<sup>2</sup> are reported where children under twelve years of age were so affected, with entire absence of any venereal or constitutional infection.

Acuminated condylomata originating in the papillary layer of the skin of the labia may appear, independently of venereal or constitutional infection, but their presence should undoubtedly be looked upon with suspicion.

The treatment of these growths is chiefly local. Solutions of corrosive sublimate in alcohol and corrosive sublimate and collodion have been

<sup>1</sup> Progress, Dr. J. M. Mathews.

<sup>2</sup> Dublin Journal of Medical Science, February 2, 1880.

highly recommended; but the speediest and most effective method is the use of the knife or of caustic, perfect antiseptis being observed.

**ELEPHANTIASIS OF THE LABIA** is certainly a rare disease in this country. I have seen one marked case, which occupied the labia and which corresponded to the usual description, though the history was indefinite. The patient did not improve under various forms of treatment, and finally was lost from observation. This girl was about fourteen years of age. Her general health remained good notwithstanding the annoying character of the affection. Virchow regards the disease as originating in the lymphatic glands. The aspect of the growth is that of an hypertrophied condition of the labia, of irregular, papillary, or cauliflower-like appearance, composed of innumerable cysts, from which there is constant oozing, causing intense irritation. The elephantoid appearance is well marked.

The question in the case mentioned was in regard to the feasibility of an amputation of the labia. Emmet, in the two cases with which he had to deal, adopted this method of treatment.

**GANGRENE OF THE LABIA.**—This seems to be generally a condition resulting from some previous lesion, either traumatic or some constitutional disturbance, as fevers, measles, and diphtheria, especially measles. It has sometimes been found in connection with embolism and hæmaturia. By some it is held that it is identical with hospital gangrene and noma. Ranke<sup>1</sup> says that different forms of gangrene resulting from noma can unquestionably occur in children who have a tendency to diseases of this kind, and he ascribes its infectious character to the presence of micro-organisms. The disease is inoculable and contagious. After an epidemic of measles in the New York Foundling Asylum in 1874, gangrenous vulvitis occurred in some of those who had been affected (Smith). Occurring on the mucous surface at one or more points, it spreads with great rapidity. The labia are of a dark, livid red, as is also the adjacent mucous membrane. Gangrenous spots appear, enlarging until the part affected is covered with a fetid slough.

**Treatment.**—Antiseptis as far as possible is one of the first requirements. If the gangrene be of the dry kind, dry, hot applications should be used,—bags of sand or bran. Cold must be avoided. Hot fomentations of borie lint or poultices may be required to stimulate the separation of slough. Chlorate of potassium has been highly praised as a local agent. E. St. George Quecely<sup>2</sup> checked ulceration by the free use of solid silver nitrate, and used as an additional application zinc ointment made with vaseline and carbolic acid. Early and thorough cauterization by nitric acid or bromine is often urgently indicated. When the labia are hard and swollen, a deep incision has proved beneficial. Sometimes the actual cautery is of use, and its rapid effect favors the idea of a local cause. Tonics, stim-

---

<sup>1</sup> Jahrbuch für Kinderheilkunde, xxvii. 3.

<sup>2</sup> Lancet, January 12, 1889.



ulants, and nutritious food are necessary for constitutional treatment. Some advise the use of quinine in large doses.

Prompt and active measures should always be employed as soon as the affection presents itself; otherwise the prognosis becomes very serious.

In all cases of gangrene or ulceration of these mucous surfaces the greatest care should be exercised to prevent the closure or narrowing of the passages by union. The parts should always be separated, and the surfaces not allowed to come in contact with one another.

**NOMA PUDENDI.**—This condition has been by some considered to be identical with gangrene, and by others to be a direct forerunner of it. Its frequent occurrence in institutions where there are many inmates points towards its infectious character, and investigations recently made suggest, if they do not actually prove, the presence of micro-organisms, though the specific cocci have not been isolated. The primary cause in children is usually some pre-existing lesion induced by irritation or inflammation. A resulting gangrene should be carefully guarded against. Antiseptics and local soothing applications are indicated, and constitutional treatment for building up the whole system. Iodoform has been recommended as a specific. (Mann.)

**LUPUS** is comparatively rare in the very young, and but few cases have been recorded. As to the exact cause there seems to be a difference of opinion. Dr. Taylor<sup>1</sup> thinks that too much prominence has been given to syphilis as a causative factor of this lesion, although it certainly has much to do with it. In children, unless it be a congenital defect, the growth may be caused by inflammation, irritation, traumatism, or some constitutional affection, as tuberculosis. The size varies, in some cases the labia becoming greatly hypertrophied and very vascular. Whether it is identical with lupus of the face is still a question, though the majority of writers still agree with Huguier, who first advanced the theory. Dr. Grace Peckham<sup>2</sup> has suggested that the term lupus or esthiomène be set aside and that of hypertrophic ulcer of the vulva substituted, prefixing as an adjective the cause of the lesion, if that be discoverable.

The treatment should be, where possible, radical. Cauterization of the ulcers and of the bleeding surfaces is recommended by Dr. Peckham. Anti-syphilitic measures are always indicated where a suspicion of a venereal or constitutional cause exists.

**TRACHOMA PUDENDORUM** is a condition which Prof. Tarnovsky, of St. Petersburg,<sup>3</sup> has found. On the labia are yellowish or grayish nodules about the size of a pin-head, "surrounded by a hyperæmic halo." The feel of the affected part is gritty, like sand, and crepitation is obtained by scratching with any hard substance. The growth contains innumerable

<sup>1</sup> New York Medical Journal, January 4, 1890.

<sup>2</sup> American Journal of Obstetrics, August, 1887.

<sup>3</sup> Jour. Akusherstva.

micrococci, which are believed to be the cause. Sometimes there is pruritus, which is relieved by cold. Prof. Tarnovsky advises superficial scarification; applications of silver nitrate, five to ten grains to the ounce of water; carbolic acid, five per cent.; or corrosive sublimate solution, in the proportion of one to two-thousand. The condition is infectious.

FOREIGN BODIES have sometimes been found to give rise to irritations of the vulva, resulting, unless discovered promptly, in serious lesions. Bökai<sup>1</sup> relates a case of strangulation of the clitoris in a young girl, produced by her having tied a piece of string around its base. In this instance a knife was resorted to. Local treatment, to relieve irritation, and the removal of the cause, are, as a rule, all that will be required, provided the lesion has not been of too long duration.

---

<sup>1</sup> Medical Press and Circular, August 29, 1889.

# DISEASES OF THE OVARIES AND TUBES.

BY HOWARD A. KELLY, M.D.

---

WHILE within the past decade familiarity with diseases of the uterine appendages—the Fallopian tubes and the ovaries—has become somewhat widely diffused, so that the general practitioner, meeting a case of long-standing severe pelvic pain, or persistent profuse menstrual flow, or other severe distress of pelvic origin, may now at least suspect the existence of something more than mere functional disorder and seek special advice, the existence of such diseases in children is not only not as yet systematically treated, but is not even ranged within the limits of the extraordinarily rare in the various text-books on pelvic pathology.

One of the most admirable scientific treatises upon the diseases of the female sexual organs in children, by Prof. Hennig, of Leipsic,<sup>1</sup> seems as yet to have attracted but little attention in the English-speaking world, and this important branch of diagnosis, pathology, and therapy still rests in the mists of the unknown. Nevertheless, the writer is convinced, from personal observation, from numerous scattered notices in the journals, and from communications from specialists, that both for the gynæcologist and for the specialist in children's diseases there lies in this direction a rich uncultivated field, which will in the future yield abundant reward to the patient collector and analyst.

The importance of a careful consideration of all the diagnostic signs associated with the pelvic diseases of girls is both absolute and relative. The subject derives its *absolute* importance from the fact that a number of localized diseases strictly limited to the pelvis, such as ovarian and dermoid cysts, and inflammation of the tubes and ovaries, have been recognized and successfully treated within the period of childhood; it derives its *relative* importance from the bearing of the proper healthy development of these organs, which is continued through childhood, upon the whole life-history of the adult. Here within the limits of childhood often creep in those localized disturbances, or diseases arising from a dyscrasia, which render the regular cyclical functional activity of these organs after puberty,

---

<sup>1</sup> Gerhardt's Handbuch der Kinderkrankheiten, 4ter Band, 3tte Abtheilung, Tubingen, 1878.

whether it be in the act of menstruation or in that of childbearing, a matter of serious difficulty or even of impossibility.

#### GENERAL CLASSIFICATION.

**Congenital malformations**, such as ovaries and tubes displaced into the canal of Nuck, or absent or rudimentary ovary or tube, scarcely come within the category of diseases, owing their existence to conditions which it is at present beyond our power to trace.

**Imperfect development** of the ovaries and tubes, by which, with the uterus and the rest of the genitals, and the body at large, these organs progressively change from the infantile type to that characteristic of puberty, is either associated with the same mysterious causes producing congenital defects, or else is connected with a retardation in the general bodily development, due to rickets, syphilis, or malnutrition, in which latter case they are more properly considered under the topics hygiene of childhood or dyscrasia.

**Tumors and Inflammations of the Ovaries and Tubes.**—Although in a quiescent developmental state, the ovaries and tubes in childhood are in a lesser degree liable to the same diseases as in adult life. Thus, numerous cases of ovarian tumors have been recorded, dermoid tumors, sarcomata, and inflammation of the tubes during exanthemata. They are also liable to tuberculosis and to syphilitic inflammation.

**Diseases due to Sexual Activity.**—If we were to take into consideration all the injuries arising in cases of rape, as well as in the early marriages in India and other tropical countries, with especial reference to phenomenal cases of childbearing in childhood, we might easily reproduce the whole domain of gynecology as pertinent to our present inquiry. However, we will not trench upon this ground further than to substantiate the fact that gonorrhœa and pus-diseases of the ovaries and tubes may be found in children.

#### DIAGNOSIS IN GENERAL.

The avenues of approach for examination, and the means of making a diagnosis of diseases of the pelvic organs in children, present very important differences from the means of approaching the same structures in the adult woman. The history, in cases associated with much pain, rests more upon very general indications as to the region of the body affected, to be determined in the case of very young children more by the habit of the body of the sufferer, in the absence of the possibility of succinct statement, and by such facts as the very unsatisfactory observation of attendant adults may have developed.

**The physical examination** has two avenues,—the rectum and the abdomen.

*The vagina*, the chief avenue of approach for the palpation of peritoneal structure in the adult, cannot be used at all in small children; and

in those who are older, and in whom a small index finger could possibly be introduced, the tightness with which the finger is grasped and the shortness of the canal very seriously limit its excursus in the attempt to palpate, demonstrating the futility of seeking information *per viam vaginæ*.

*Rectal Palpation.*—The rectum, however, offers an approach as satisfactory as the vagina is unsatisfactory, for by means of a carefully-applied rectal touch much more can be discovered than by both rectum and vagina in the adult. The lower bowel should be well emptied beforehand by a soap-and-water injection, and the index finger, with a short nail and well oiled, gently introduced, avoiding with the utmost care any roughness or haste in the procedure, thus obviating any lacerations of the delicate integument at the anal orifice, or the more serious injury, not only possible, but probable under a rough examination, of rupture of the coats of the bowel.

The difficulty sometimes experienced in the adult in finding the lumen of the bowel above the large lax ampullar distention (the rectal pouch) does not exist here, and the smaller and straighter canal is readily followed by the index finger gently pushing its way upward into the pelvis.

While in the adult the finger can with difficulty reach the deeper portions of the pelvis, and often reaches the ovaries and tubes only by firm upward pressure, with considerable invagination of the skin-surface, in the smaller pelvis of the child the finger at once easily touches all parts.

Upon pressing forward with the pulp of the examining finger, the first object distinctly recognized is the relatively bulky cervix; above this can be traced, like a broad cord, the uterine body. The ovaries and tubes, if enlarged in any way or involved in inflammatory masses, can be distinctly recognized, but in the normal condition cannot be separated from numerous similar structures felt gliding over the pulp of the finger.

*Combined Rectal and Abdominal Palpation.*—While the rectal touch is the most certain way of approaching tubes and ovaries to be questioned as to their condition of health or disease, the same examination combined with palpation by the other hand *per abdomen* is greatly enhanced in its value.

(Fig. 1.) Thus, while soft, yielding, and small structures escape the detection of one hand by gliding at once to one side or the other as soon as pressure is made upon them, when counter-pressure is made by means of the outside hand pushing down thoroughly the superior strait from above, all the structures in question are readily caught and detained, and their relations and consistence determined without difficulty.

In this way the uterus is most clearly felt, the ureters, on account of their peculiar course, are readily palpated, the ovaries are often recognized, and the tubes, in common with the other broad-ligament structures, slip with a characteristic jumping sensation between the fingers.

*Anæsthesia in the Pelvic Examination of Children.*—In well-

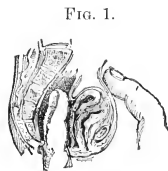

FIG. 1.  
Rectal and bimanual palpation in the child.

conditioned children, where the belly-walls are often very fat and distended, or where resistance is probable or much pain is liable to be produced in the course of an examination which it is important should be thorough, it is best to anaesthetize at once. Indeed, anaesthesia is advisable in almost all cases, so rapid is it in taking effect, so short is the duration, and so slight are the after-effects. The entire relaxation, and the absence of all resistance, thus produced afford every facility for the most complete examination.

**Exploratory Incision.**—In all cases of doubtful diagnosis where the health or life of the child seems seriously threatened by an abdominal growth, the exploratory incision offers a safe and satisfactory solution of the difficulty. If the growth is of such a nature that it can be removed, the operator should be ready to complete the operation at once; if, however, owing to its attachments, it is impossible to remove it, the incision can be closed within five or ten minutes, and the patient left in no worse condition than she was in immediately before this simple operation. The incision should be carefully made in the median line, beginning about an inch above the symphysis pubis, and extending an inch and a half upward. After incising the skin, the subcutaneous fat, the white tendinous structures composing the linea alba, and the subperitoneal fat, the peritoneum appears as a delicate membrane, which should be picked up between two forceps, raising it in a distinct fold; a slight nick with the knife opens the sac, and at once the air enters the small opening and the intestines drop away out of the reach of danger. Removing the forceps and introducing both index fingers into this opening, it should then be torn to the full extent of the external incision, after which one finger can be carried into the pelvis to conduct the exploration.

It is best to explore in an orderly manner, according to rule, seeking out the uterus first, as a landmark most easily recognized, then palpating to the right and to the left from this as a fixed point, over the broad ligaments, tubes, and ovaries.

It frequently happens that a considerable accumulation of ascitic fluid is found at the same time. A great deal of relief will often be experienced if nothing more is accomplished than its complete evacuation.

In thin walls six and in thick walls four silk sutures will close the incision. A powder of iodoform and boracic acid (R Iodoformi, ʒss; Pulv. acidi borici, ʒiv. M.) having been dusted freely on the line of incision, absorbent cotton placed over this, and an abdominal bandage applied, the patient is ready to be lifted from the table and returned to bed.

The dressing need not be disturbed for a week, when all the sutures are removed at once, and the sides of the incision supported for a week longer by narrow adhesive strips.

It rests with the general practitioner to conduct these cases to a specialist and to afford them the benefit of this procedure. There is no possible reason why the rule so universally recognized in the treatment of doubtful conditions in the adult should not equally apply to the child. Simple as the

exploratory incision is, its safety lies in the most rigid application of the antiseptic principle throughout. Carelessly undertaken, in forgetfulness of this principle, it will surely entail a certain percentage of deaths.

#### OVARIAN TUMORS.

In Sir Spencer Wells's list of one thousand ovariectomies, three operations upon children are recorded, giving an average which probably exhibits with some degree of accuracy the relative frequency of this affection in juvenile and in adult life, some allowance being made for the fact that children are not so readily brought to operation as adults.

The largest tumor ever removed from a child was operated upon by Dr. H. Marion Sims (personal communication) in 1883. The patient, aged eleven and a half years, came to Dr. Sims from Tarrytown, New York, where she had not escaped the comment of the village gossips, who declared her to be in a family way. Her abdomen was enormously distended, and she had been unable to lie down for several months. Dr. Sims diagnosed a multilocular ovarian cyst, and operated, removing a cyst made of loculi containing solid and fluid material. The whole tumor weighed sixty-one pounds, the patient weighing seventy-six pounds. The recovery was excellent, and the patient is still living and well.

Such an operation, trying the mettle of the operator and the endurance of his frail patient, teaches us in no undecided manner what skilful aid may do even in the most extreme cases.

The smallest tumor of which I find a record of operation in childhood is a case recorded by T. Spencer Wells.<sup>1</sup> The tumor weighed but two pounds. The little girl, eight years of age, was a patient of Dr. Lane, of San Francisco: she made a good recovery, and was living and well seven years later.

Dr. Boldt, of New York, has operated upon a patient four years old.

Dr. Joseph Taber Johnson, of Washington, has had two cases of ovarian tumors in children. The first patient, twelve years old, was referred to Dr. Thomas, of New York, who removed a sixteen-pound ovarian cyst; within a year a tumor equally large developed in the other ovary, and before she could be operated upon this burst, and she died suddenly.

Dr. Johnson has himself operated upon a girl of thirteen, removing successfully a tumor weighing eight pounds; she was fifteen at date of writing, and had not yet menstruated.

Prof. Koerberlé, whose genius has anticipated most of the steps of modern advanced gynecology, reports a case<sup>2</sup> in the *Gazette Médicale de Strassbourg*, 1876, in which he successfully operated upon a girl aged thirteen, removing a large multilocular ovarian cyst through an incision sixteen centimetres in length.

<sup>1</sup> Ovarian and Uterine Tumors, London, 1882, p. 374, Case 604.

<sup>2</sup> Hennig, loc. cit., p. 48.

**Diagnosis of Ovarian Tumors.**—The diagnosis of an ovarian tumor will be made by the discovery of a large multilocular encysted mass of slow growth springing from a pelvic attachment, yielding everywhere over its mass a flat percussion-note.

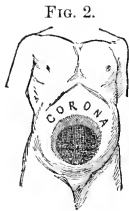

FIG. 2.  
Area of tympany around an ovarian tumor, called the "corona ovariana."

The ovarian tumor, having a pedicle at the broad ligament of greater or less length, and being free to move, as soon as it escapes from the pelvis is floated up and pushed to the front by the lighter intestines; in this way a dull area corresponding to the prominence of the tumor is produced, while above the tumor, and pressed down into the flanks, lie the intestines, giving a crescentic area of tympany, appropriately called the *corona ovariana*. (Fig. 2.)

**DIFFERENTIAL DIAGNOSIS.**—The importance of being able to make a correct diagnosis before operation has greatly diminished since the safety of the exploratory incision has been established, but for scientific accuracy every simple means at our command will naturally be first employed.

The *exploratory puncture*, so much employed a few years ago, in the days when "humoral" pathology held sway in the study of abdominal tumors, will now, in view of its uncertainty as a means of diagnosis, and its dangers, and of the equal if not greater safety, with the added certainty, of the exploratory incision, be scarcely admitted under any circumstances. The diagnosis will be determined upon the facts afforded by the history, inspection, percussion, and palpation. The differential diagnosis of any single disease in the realm of medical science derives its importance not from the lengthy list of all the various pathological conditions which can be enumerated as bearing any of its important characteristics and hence liable to be mistaken for it, but from a certain class or classes of conditions which are constantly cropping up and in one way or another demanding separation from the disease in question. The disease thus acquires, apart from the characteristics which it has when viewed alone, a certain definite physiognomy derived from its more or less constant relation or association with other diseases. Some of these characteristics are equally appreciated by all operators, while to a certain extent the difficulties and experiences of each particular operator give a certain amount of individualization to the disease in question. Thus, "cystic ovarian tumor" in the adult at once calls up a well-defined picture of fibroid and fibro-cystic tumor, of dermoid and parovarian cysts, with a background of renal, splenic, intestinal, mesenteric, and malignant ovarian tumors. In children, on the other hand, the picture of the conditions which are liable to cause an error in the diagnosis thus summoned is very different. They are dermoid cysts and sarcomata of the ovaries, and malignant and cystic renal diseases, together with various atypical retro-peritoneal renal affections. The prognosis in children, therefore, in advance of accurate investigation, is far more serious than in adults.



It is not the purpose of the writer to enter elaborately into the intricacies of differential diagnosis. Suffice it to say that *dermoid cysts* are frequently found double, and are of much slower growth than ordinary ovarian cysts, and consequently (as Hennig observes) are much more liable to be carried over into the years of puberty than the ovarian cysts.

*Malignant diseases* in general are to be distinguished by their more rapid growth and by the marked affection of the general health of the patient, as well as by the frequent association of large ascitic accumulations.

If this accumulation be tapped under the impression that it is an ascites proceeding from hepatic or renal disease, the fluid will often be of a deep-red color, from the abundant red blood-cells present, or will contain in the thick sediment vacuolated or round and spindle cells. At other times the examination of the fluid is perfectly negative.

In retro-peritoneal disease of a malignant nature, when the tumor springs from the pelvis its base is broad, and hence it is more or less immobile, and the function of one pelvic organ or another is often seriously interfered with. Thus, in the case of a child three years old in the hands of the writer, a soft sarcoma eight centimetres in diameter, springing from the anterior face of the sacrum, in position, shape, and consistency closely simulated an ovarian cyst, but its retro-peritoneal origin was to be inferred from the marked deviation of the rectum and from the frequent agonizing efforts at micturition caused by a large hydro-ureter of the right side.

Malignant or congenital cystic disease of the kidneys requires careful consideration and separation from ovarian tumors. In a certain percentage of cases<sup>1</sup> of malignant disease hæmaturia will give the clue to the difficulty; in the majority of cases the urine is in no respects abnormal.

Before the tumor has reached a size sufficient to fill more than one-fourth of the abdomen, its renal origin may be detected by the reniform shape, by its position more in one or other (chiefly the right) flank, by the greater facility with which it can be displaced into either lumbar region, and, above all, by the clear percussion-note over the tumor. When larger in size, the more elongate barrel-shaped abdomen contrasts markedly with the prominent spheroid of the ovarian cyst. In some cases the exploratory incision alone will solve the difficulty.

An enlarged spleen is to be recognized by its notched border, its regularity of outline, and its peculiar resistance, together with the mobility and the readiness with which the tumor can be displaced into the left hypochondrium and its evident want of pelvic attachment.

**Technique of Ovariectomy in Children.**—The conduct of the operation for the removal of an ovarian tumor in a child is, in general, similar to the same operation in the adult, and may be briefly summed up in the stages enumerated below.

Daily baths should be given beforehand, to cleanse and soften the skin.

---

<sup>1</sup> Three times in twelve cases, according to Dr. Victor Faludi.

Twenty-four hours before the operation, the bowels should be well opened; and half an hour before, a small dose of morphine with thirty grains of subnitrate of bismuth should be administered, to insure contraction of the intestines.

1. Perfect antiseptis (whether attained by a thorough preliminary use of soap-and-water or by chemicals).

2. An incision in the linea alba large enough to allow rapid work.

3. Exposure of the cyst, and puncture and evacuation of its contents.

4. Turning the cyst inside out, like an inverted sac, through the incision.

5. Ligation of the pedicle in two or more parts.

6. Cleansing of the peritoneum, including the removal of all water, escaped cystic contents, and blood, usually gravitating into Douglas's pouch and the iliac fossæ.

7. Drainage by means of a straight glass tube, if there is any persistent oozing, or complete closure of the incision by means of silk sutures, about four to the inch.

Adhesions to abdominal walls, pelvic viscera, omentum, and intestines must be separated with extreme care, so as to leave no bleeding points, and to avoid sacrificing any of the coats of the viscera. This can be accomplished where the tumor is attached to the omentum, or where the adhesions are in the form of bands, by double tying and cutting between. Flat adhesions can be separated by carefully peeling apart the annexed surfaces with thumbs and forefingers, always remembering that, if the adhesion is inclined to tear, the coats of the tumor which is being extirpated must be sacrificed.

In one important respect this operation when performed in the child differs from the same operation in the adult,—that is, in the far greater liability to serious shock. It is necessary to bear in mind continually that the size of the tumor in proportion to that of the subject is far greater in children, that the relative exposure to evaporation and loss of heat is much greater, and that the same loss of blood which in the one case would at the most produce a shock to be recovered from in two or three days would in the other prove inevitably fatal.

The same rule applies also to the time consumed in the operation. The diminished powers of resistance of the more delicate child's organism must be constantly borne in mind.

#### DERMOID CYSTS.

Dermoid cysts are frequently met with in childhood. In the closed abdomen they present all the characteristics of simple ovarian cysts. They contain abundant fat, either liquid or of a tallowy consistence, skin, hair, sebaceous and sweat glands, bones, and teeth. They are much slower in growth than ovarian tumors, and hence are liable to be carried much longer, even into the years of puberty.

## CANCER.

Cancer of the ovary has been observed in childhood. Hennig (*loc. cit.*) was able to collect four cases in 1878, in addition to which he has since added the references cited at the end of this article.

The writer operated upon a remarkable case of this kind several years ago. The patient, twelve years old, was an unusually bright child, of very slight frame. The abdomen began to swell very suddenly. She was tapped a number of times, discharging dark bloody fluid containing round cells. The fluid reaccumulated very rapidly, and she was evidently fast becoming exhausted by the drain. At the operation the writer removed a large sarcoma of the ovary, flat, and large enough to fill a hat, attached by a broad membranous pedicle, about an inch and a half in length, to the left broad ligament. The patient made a perfect recovery, but succumbed two years later to an attack of dysentery.

## TUBERCULOSIS.

Tuberculosis of the ovaries or tubes will with difficulty be recognized during life, or will at the utmost be detected upon making an exploratory incision.

Hennig cites a case of a child from Amboyna, twelve years old, who had tubercular disease of both ovaries, one tube, and the uterus. Gusserow (see literature by Hennig) reports cases of tuberculosis of the ovaries and uterus without participation of the tubes, and Kiwisch and Neureutter cite cases of tuberculosis of the tubes and uterus.

## PUS DISEASES.

Inflammatory diseases involving the tubes and extending to the ovaries, sealing the tubes, or extending to the pelvic peritoneum, undoubtedly occur, although rarely reported.

Dr. M. Sänger, of Leipsic, related to the writer a case in which a man with gonorrhœa infected his whole family, including a little daughter, who developed all the symptoms of an acute pelvic peritonitis, in common with a well-marked gonorrhœa, from which she recovered only after a protracted illness.

Dr. Edis<sup>1</sup> reported a case of a child twelve years of age, dying after a wasting illness of four months, in which he found a pelvis full of pus surrounding a ruptured ovary and a cheesy tube.

## EXANTHEMATOUS INFLAMMATION.

As early as 1851 Hennig observed hyperæmia and infiltration of ovaries and tubes in scarlet fever.

The effects of the severer forms of the exanthemata upon the female

<sup>1</sup> Lond. Obstet. Soc. Trans., 1872.

genitals urgently demand more careful observation and the report of a number of cases, to assist in determining the relation of these diseases to dysmenorrhœa, sterility, and imperfect development in later life.

---

BIBLIOGRAPHY.

In addition to the references given in Prof. Hennig's monograph referred to in the text, I am indebted to his courtesy for the following records of operations upon ovarian tumors.

- Küster, *Zeitschr. f. Geb. u. Gyn.*, x. 164.  
 Kidd, *Dublin Quarterly Journal*, Feb., 1880.  
 Römer, *Deutsch. Med. Wochenschr.*, Dec. 26, 1883.  
 Schröder, *Zeitschr. f. Geb.*, ix., 1882.  
 Thornton, *British Medical Journal*, Dec. 10, 1881.  
 Chenoweth, *American Journal of Obstetrics*, 1883.  
 Péan, *Gazette hebdomadaire*, Nov. 21, 1879.  
 Kaltenbach, *Wien. Med. Blatt*, xxix., 1880.  
 Neville, *New Dublin Journal*, 1880.  
 Busch, *Pitha-Billroth*, vol. iv. Part 9.  
 Schwartz, *Arch. f. Gyn.*, xiii., 1878.  
 Barker, *Richmond and Louisville Journal*, 1879.  
 Thiersch and Wagner, *Arch. f. Klin. Chir.*  
 Howard, *Lancet*, May 15, 1886.

See also the following :

- Winckel, *Path. d. weibl. Sex.-Org.*, Taf. xxxvi. ; *Lancet*, Dec. 16, 1871.  
 A. Leared, *Trans. Lond. Path. Soc.*, xxix. 171.  
 Ch. Talamon, *Ann. de Gyn.*, 1878, ix. 416.  
 Schnobel, *Württemberg. Correspondenzblatt*, p. 10, 1844.  
 H. Unverricht, *Breslauer Aerzt. Zeitschr.*, No. 2, 1879.

*Tuberculosis :*

- Talamon. Five cases under fifteen years.

*Cancer :*

- E. Evers, *Courier of Medicine*, St. Louis, Aug., 1884. Cancer in a child two and a half years old.  
 Barth, *Leipsic*. Case in a child of ten years.  
 Schröder, *Zeitschr. f. Geb. u. Gyn.*, Berlin, 1883, ix. 369.

# ABNORMALITIES OF THE FEMALE GENITAL ORGANS AND MAMMARY GLANDS.

By CLARA MARSHALL, M.D.

---

ABNORMALITIES of the female sexual organs when studied in connection with the development of the human embryo no longer assume the character of natural curiosities, but become explainable, in the large majority of instances, under the head of *arrest of development*. To the scientific student they are of perhaps greater interest than are the normal types, because in them is afforded an opportunity to study in a permanent form certain transitory embryonic states. These malformations have been aptly spoken of as "development caught in the act and fixed permanently for after-investigation."

The space allotted to this paper will permit only a cursory glance into this illimitable and fascinating field of investigation.

Since most of the malformations of the genitalia do not receive attention and are not even suspected until some defect in function demands relief, it happens that most of the recorded cases are those which were seen first in adult life. This being the case, it necessarily follows that most of the illustrations made use of by the writer have been taken from reports of cases which were noted at or after the period of puberty.

Some account has already been given of the normal anatomy of the female sexual organs at birth, and allusion has been made to their mode of development (vol. i. pp. 41, 42). It may be well, however, to refer to the fact that the Fallopian tubes, the uterus, and the vagina are developed from the ducts of Müller, which appear first as solid filaments, and then as tubes whose walls approach each other and afterwards (at the lowest part) coalesce, with a final absorption of the septum so that the two tubes unite in one, forming the uterus and vagina. Above they remain separated as the right and the left Fallopian tube. The illustration on the following page (Figs. 1, 2, 3, 4), from Skene, is suggestive of these changes.

## OVARIES.

The rarest of all the abnormalities of the sexual system is the *absence* of both ovaries, and it is also the abnormality which is most frequently

associated with defective development of the remaining sexual organs. According to Courty, "in two-thirds of the cases in which absence of the ovaries has been observed, the vagina, uterus, and Fallopian tubes were also absent; in the remaining third the uterus existed, but was imperfectly

FIG. 1.

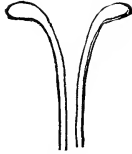

Müller's ducts.

FIG. 2.

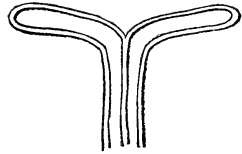

Coalescence of ducts.

FIG. 3.

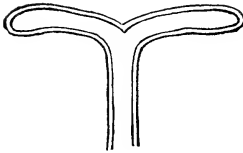

Disappearance of septum.

FIG. 4.

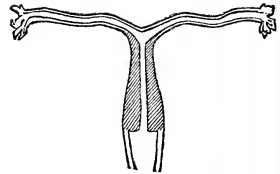

Appearance of fundus and cervix.

developed, presenting after puberty the characteristics of fetal or infantile life." A diagnosis of this condition during infancy and childhood is not likely to be made except upon the post-mortem table; it may be suspected at puberty if there is no evidence of ovulation, and especially if there is evidence of the non-existence of the uterus and vagina.

*Rudimentary ovaries* in the living subject are diagnosed or suspected for the same reasons as those just given. While rudimentary ovaries may exist with a fully-developed uterus and external genitalia, they are far more frequently found in connection with a rudimentary uterus. It is also important to remember that occasionally fully-developed ovaries may be found associated with non-development of the uterus.

The ovaries may be more or less deeply notched, or the fissure may be so extensive as to divide the ovary into two segments, not a very rare abnormality; or there may be an *accessory* ovary: in a most interesting case of the latter condition reported by Winkel there were three ovaries and three ovarian ligaments.<sup>1</sup>

The presence of a third ovary becomes of especial significance during the child-bearing period, as a probable explanation of those rare cases of pregnancy following a double ovariectomy.

A *single* ovary is not unfrequently associated with a one-horned uterus and upon the same side with the undeveloped horn.

The ovaries are developed in the abdomen, gradually descending during

<sup>1</sup> Pathologie der weiblichen Sexualorgane, p. 28, table xxxiv., Fig. 7.

intra-uterine life, reaching the brim of the true pelvis at birth, and after birth gradually assuming their final position at the sides of the pelvis. There may be *excessive descent*, in which case the ovary may be found in the inguinal canal or even in the labium majus, and it may drag with it the Fallopian tube and the uterus.

FALLOPIAN TUBES.

Among the abnormalities of the Fallopian tubes their complete *absence* (usually associated with absence of the uterus) is first in the order of rarity.

Remembering the origin of the Fallopian tubes from Müller's ducts, it is very easy to understand that there may be any degree of departure from the normal type, corresponding to the stage of development at which the arrest has taken place. Absence of one tube is usually associated with a uterus unicornis.

The tubes may be *rudimentary*, or they may be supplied with *supernumerary fimbriae* together with *supernumerary ostia*; or they may fail to descend from the lumbar region, or there may be *excess of descent* (hernia): the Fallopian tubes may descend alone (this is very rare) into the inguinal canal, or, as is more frequent, they may accompany descent of the ovaries.

UTERUS.

The uterus in the child is higher above the pelvic brim than in the adult, and, if so movable an organ can be said to have a normal position, its most frequent position is that of slight forward inclination, with flexion of the body upon the cervix. The position of the uterus, together with its relations at birth to other organs and to the pelvic cavity, is illustrated by Fig. 5, from Courty.

Fig. 6, also from Courty, illustrates the following characteristics of the uterus at birth: its size, the distribution of the arbor vitæ, which extends to the fundus, the absence of an internal os, the two cavities of the body and the neck being continuous with each other, the larger size of the neck and its relatively thicker walls as compared with the body, the shortness of the vaginal portion of the cervix and its cylindrical shape. The body is more flattened than in the adult, and its upper border is straight or even slightly concave.

FIG. 5.

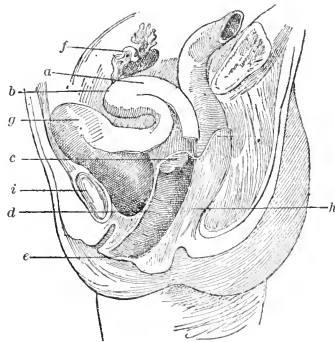

UTERUS OF A FŒTUS AT BIRTH, side view, seen in its relations, showing the normal ante-flexion natural during fetal and infantile life. (From Courty, after Boullard and Bourguery.)—a, body of uterus flexed forward; b, fundus uteri looking forward; c, cervix; d, vagina; e, hymen; f, Fallopian tube, behind which the ovary is seen; g, bladder; h, rectum; i, symphysis pubis.

If the growth of the organ stops at this point, the characteristics which have just been described as normal in the child constitute in the adult an abnormality correctly styled the "infantile uterus."

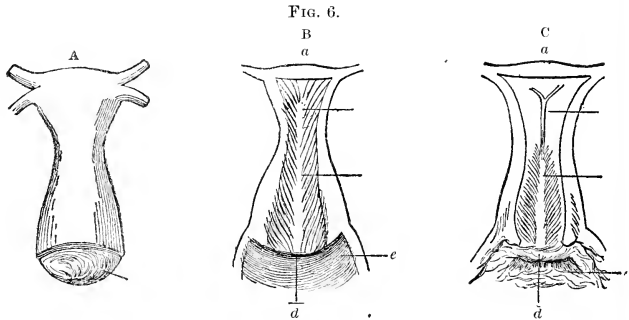

The uterus may be *absent*, in which case there is usually absence of or defect in other portions of the genital system or elsewhere in the body.

*Rudimentary Uterus.*—The uterus may consist of a band of connective tissue interspersed with muscular fibres; it may be a solid nodule of fibrous

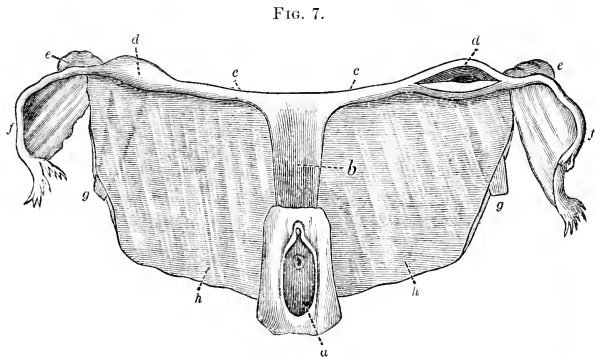

UTERUS BIPARTITUS.—*a*, vagina; *b*, a band of cellular tissue mixed with muscular fibres, having the form of a uterus; *c*, *c*, muscular cords representing the uterine cornua and terminating in enlargements, *d*, *d*, of the size of a bean, hollowed out into a cavity capable of holding a lentil and lined with mucous membrane; *e*, *e*, rudimentary ovaries; *f*, *f*, oviducts; *g*, *g*, round ligaments; *h*, *h*, broad ligaments. (Küssmaul, after Mayer.)

tissue; it may be that rudimentary form described by Mayer, in which the position usually occupied by the normal uterus is filled by a body composed of muscular fibres and connective tissue, and sending off from each side of



its superior border a cord, ending in a swelling, which may or may not be solid, and which is found at the insertion of the round ligament. Fig. 7 represents such a uterus, which was named by Mayer *uterus bipartitus*.

FIG. 8.

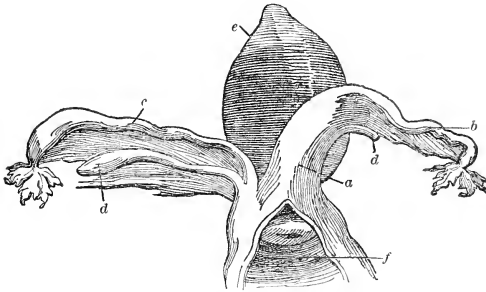

UTERUS UNICORNIS OF A CHILD, seen from behind. (After Pole.)—*a*, right unicorn uterus; *b*, right Fallopian tube; *c*, left Fallopian tube; *d*, *d*, ovaries; *e*, bladder; *f*, vagina, in which is seen the uterine orifice.

This form of non-development is not necessarily associated with non-development of the ovaries. The breasts and external organs of generation may also be well developed.

*Uterus Unicornis*.—In this variety of arrest of development one Müllerian duct has been developed while the other is either entirely absent or exists in a rudimentary state. The fundus (if we may be allowed so to call the fully-developed single horn) is curved to one side, and is continuous with the Fallopian tube and ovary. There may or may not be a Fallopian tube and ovary connected with the undeveloped horn of the uterus. There may be an absence or a rudimentary condition of the kidney on the same side with the undeveloped horn. (Fig. 8.)

*Uterus Didelphys*.—This deformity originates in an entire want of contact of those portions of the Müllerian ducts which should by their coalescence form the uterus. Consequently there are two separate uteri, or rather the two halves of the uterus are separate. (Fig. 9.)

This variety is also known as *uterus duplex separatus*.

FIG. 9.

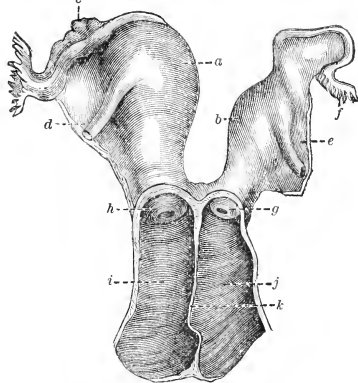

UTERUS DIDELPHYS.—*a*, right cavity; *b*, left cavity; *c*, right ovary; *d*, right round ligament; *e*, left round ligament; *f*, left tube; *g*, left vaginal portion; *h*, right vaginal portion; *i*, right vagina; *j*, left vagina; *k*, partition between the two vaginæ. (De Sinéty, after Ollivier.)

FIG. 10.

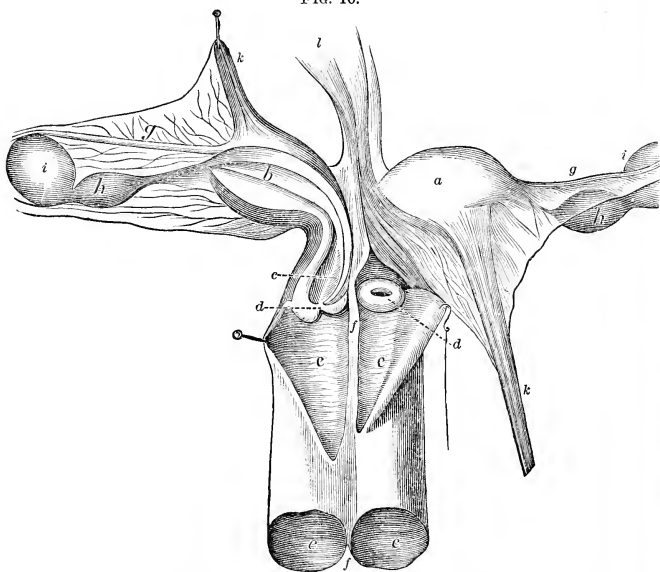

UTERUS BICORNIS DUPLEX.—*a*, left horn; *b*, cavity of right horn; *c*, right cervical canal; *d*, *d*, external orifices; *e*, *e*, the two vaginal canals; *f*, the partition between the vaginal canals; *g*, *g*, tubes; *h*, *h*, ovaries; *i*, *i*, cysts of the ovaries; *k*, *k*, round ligaments; *l*, suspensory ligament of uterus. (Küssmaul, after Cassan.)

FIG. 11.

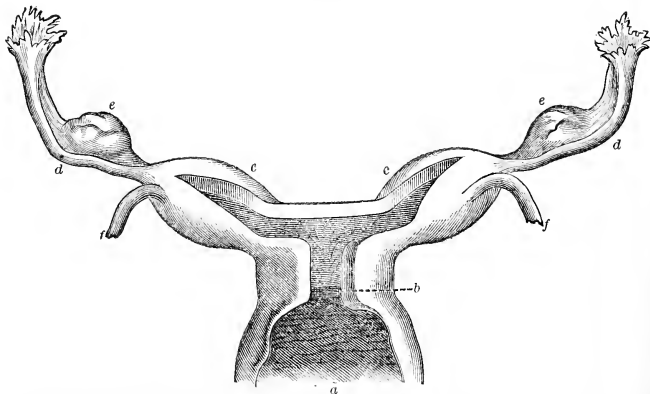

UTERUS BICORNIS UNICOLLIS.—*a*, vagina; *b*, single neck; *c*, *c*, horns; *d*, *d*, tubes; *e*, *e*, ovaries; *f*, *f*, round ligaments. (From Küssmaul.)

*Uterus Bicornis*.—If those portions of the ducts of Müller which coalesce to form the upper part of the uterus fail to unite, the result is a

FIG. 12.

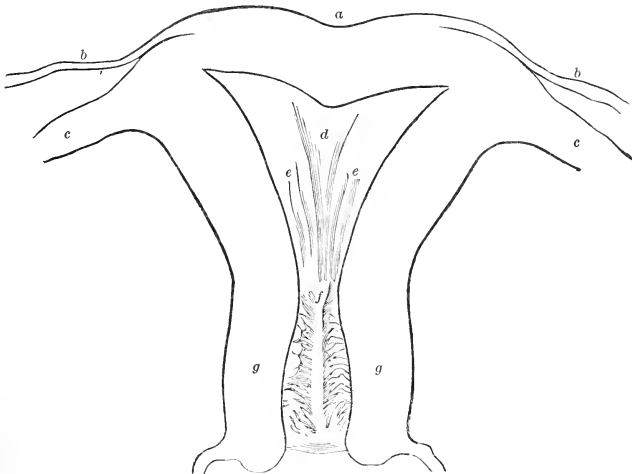

UTERUS ARCUATUS.—*a*, indented fundus; *b, b*, tubes; *c, c*, round ligaments; *d*, central longitudinal ridge on the posterior wall of the cavity of the body; *e, e*, lateral ridges of the same; *f*, internal os; *g, g*, cervix uteri. (From Küssmaul.)

two-horned uterus. If the cavities remain separate throughout, it is known as a *uterus bicornis duplex*. (Fig. 10.)

There may be a two-horned uterus with a single cervix,—*uterus bicornis unicollis* (Fig. 11).

A very slight tendency to separation may exist, shown by a depression in the fundus, and, from its resemblance to a heart, such a uterus is known as *uterus cordiformis* (*uterus arcuatus*) (Fig. 12).

FIG. 13.

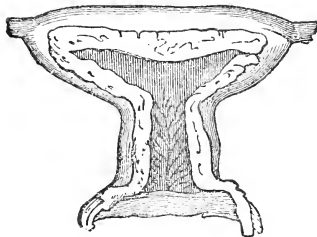

UTERUS INCUDIFORMIS.

Or there may be the anvil-shaped uterus, in which the upper border does not present the normal degree of convexity (*uterus incudiformis*) (Fig. 13).

*Uterus septus* is one which to outward appearance is normal, but in which the cavity is divided by a longitudinal septum into two halves. A complete division constitutes a *uterus septus duplex* (Fig. 14).

FIG. 14.

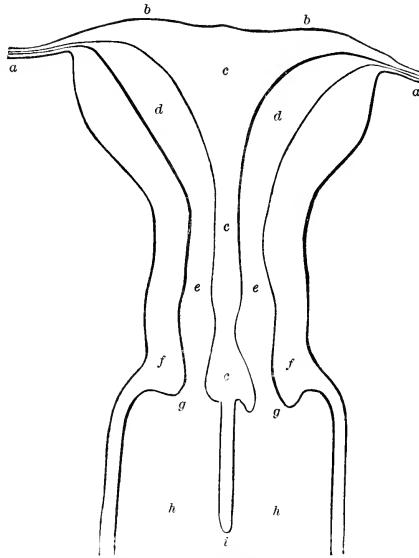

UTERUS SEPTUS DUPLEX.—*a, a*, tubes; *b, b*, fundus of double uterus; *c, c, c*, partition of uterus; *d, d*, cavities of uterine bodies; *e, e*, internal orifices; *f, f*, external walls of the two necks; *g, g*, external orifices; *h, h*, vaginal canals; *i*, partition dividing the upper part of the vagina into two halves. (From Küssmaul.)

If the septum is incomplete, the deformity is known as *u. subseptus*; and again the *u. subseptus* has various subdivisions according to the extent of the septum. If the partition extends from above downward to the external os (leaving one os), it is a *u. subseptus unijoris*: a still shorter partition, just reaching the internal os, is a *u. subseptus unicollis*. The vagina and neck may be divided without division of the body of the uterus.

*Uterus parvicollis* is one in which the neck is undeveloped. *Uterus acollis* is one in which the neck is absent.

*Hernia of the Uterus*.—Congenital inguinal hernia may be complicated with hernia of the uterus, or much more frequently with hernia of the uterus and its appendages, in which latter case the appendages descend first and the uterus is dragged down afterwards. Courty states that in the "Atlas of Bovin and Dujes, Pl. XI. Fig. 3, there is a drawing after Cloquet of a right *crural* hernia of the uterus, ovaries, and Fallopian tubes in a newly-born child, in which the fundus of the uterus seems to have been first displaced."

## VAGINA.

The vagina may be *absent*, being represented only by a cord, in which case the uterus may be absent, rudimentary, or well developed. It may be narrow (*stenosis*), frequently associated with a bicorn uterus. It may be *double*, a continuation or not of a so-called double uterus. It may be entirely closed (*atresia vaginæ*) by one or more transverse septa or by an imperforate hymen (*atresia hymenalis*). In the "London Obstetrical Transactions" for 1887 (vol. xix.) a case is reported in which atresia of the vagina was found in a newly-born child combined with a large cyst formed by the distended upper part of the canal and occupying most of the abdomen: the uterus communicated with the cyst.

## HYMEN.

The hymen, according to recent observations, especially those of Tardieu, may vary greatly in appearance, even within normal limits. The most marked abnormalities are imperforate hymen (absolutely no opening), biperforate hymen (two openings), which may or may not be continuous with a double vagina, and eribriform hymen (perforated like the rose of a watering-pot). The hymen may be the site of congenital cystic growths.<sup>1</sup> Reported cases of congenital *absence* of the hymen rest upon a somewhat doubtful basis.

## VULVA.

There may be absence of the vulva (in monstrosities), or its elements may be slightly developed, or there may be excess of development of the labia or nymphæ, which may be double or triple in number, or they may be quite beyond the usual proportions, or there may be a bifid clitoris (due to arrest of development), or the clitoris may be undeveloped, or there may be union of the greater or lesser labia. This last condition is one of the few abnormalities of the sexual organs which may be detected, and, where the union is superficial, may be easily operated upon during infancy or early childhood: failure to separate the labia by early surgical interference may result seriously in adult life (difficult coitus and parturition). A combination of some of the above features—viz., large bifid clitoris, with union of the labia up to a point which will just allow of exposure of the clitoris (thus simulating a scrotum), with hernia of ovaries into the labia—gives an appearance of female hermaphroditism. There may be a cleft in the anterior wall of the urethra (*epispadias*) or in the anterior wall of the bladder (*extroversio vesicæ*), or a deficiency in the posterior wall of the urethra (*hypospadias*). These abnormalities, together with the subject of hermaphroditism, are considered elsewhere in this volume.

## ANOMALIES OF COMMUNICATION.

If at that period of embryonic life at which the hollow organs of the genito-urinary system together with the rectum communicate with a

<sup>1</sup> Archiv f. Gynäkol., 1884, vol. xxiii. p. 427.

common cloaca there is a partial or complete arrest of development, the result is seen after birth in anomalies of communication, to which belong the congenital recto-vaginal, uro-vaginal, and uro-recto-vaginal fistulae. Any of these abnormal passages may be associated with an imperforate rectum or anus. Imperforation of the vagina may exist with an opening between the vagina and the rectum allowing in after-years of the escape of the menstrual fluid through the anus. In a case which came under the observation of the writer the septum which separates the rectum from the sinus uro-genitalis, and which is completed in the tenth week of embryonic life, had never been developed, and as a consequence the rectum opened into the vagina and the anus was marked by a simple pitting of the skin. In another case of imperforate anus the rectum opened just within the fourchette. These and other abnormalities are much more clearly made out in the adult, because of the larger size of all the parts which enter into the deformity.

#### EXCESS OF DEVELOPMENT.

Under the above head may be classed the rare cases of very early sexual development: this excess in growth usually corresponds with precocious menstruation, this function having been established in some instances at a very early period of the child's history, and even, it is stated, in the new-born. One of the most interesting cases of early sexual development is that reported by Dodd,<sup>1</sup> of a girl who began to menstruate at twelve months of age and who became pregnant during her ninth year, being delivered of a child weighing seven pounds, and this, too, after a labor which was not difficult. There was a profuse growth of hair in the axillæ and on the pubes, and the breasts were well developed and secreted a good supply of milk. Another reported case of pregnancy, with abortion at the end of four weeks, in a child aged eight years, seems to be authentic.<sup>2</sup> Dr. A. Vander Veer<sup>3</sup> reports the case of a girl who began to have a regular menstrual flow at the age of four months. Dr. Cortejarena calls attention to the fact, as illustrated by a case reported by himself, that the mental and moral development does not necessarily correspond with the physical evolution.<sup>4</sup>

#### ABNORMALITIES OF THE MAMMARY GLANDS.

The most frequent abnormalities of the mammary glands are included under the two heads of supernumerary mammeæ (*polymastia*) and supernumerary nipples (*polythelia*).

<sup>1</sup> Lancet, April 9, 1881, p. 601.

<sup>2</sup> Journal des Sciences Médicales, No. 5.

<sup>3</sup> American Journal of Obstetrics, September, 1883.

<sup>4</sup> El Siglo Médico; Le Réveil Médical, 1880, p. 202.

Rudimentary mammae and nipples were at one time considered to be of extremely rare occurrence and to be confined in the majority of cases to females, but, thanks to Leichtenstern<sup>1</sup> and others, both of these opinions have been greatly modified. Leichtenstern estimates (this is only an estimate, and not an accurate calculation) the occurrence of supernumerary nipples and mammae, taking the two sexes indiscriminately, to be one to five hundred. Dr. J. Mitchell Bruce<sup>2</sup> found in a series of cases including both sexes, examined by himself, that the abnormality occurred in more than seven out of one hundred cases. The mistaken belief in the greater frequency of the anomaly in the female than in the male, together with its explanation, has received consideration by Leichtenstern and subsequently by others. The mammary gland being rudimentary in boys, and hence not assuming functional activity, it is not strange that many cases are overlooked; even in girls the anomaly may not be noticed or even suspected until, the function of lactation being established, the presence of a secreting gland in an abnormal situation for the first time attracts attention. It is not always noticed even in the first pregnancy, cases being recorded in which it is asserted that the anomaly was not observed until the sixth or seventh pregnancy.<sup>3</sup>

A systematic observation of a series of persons of both sexes, such as that undertaken and reported by Dr. J. Mitchell Bruce, establishes the fact that supernumerary mammae and nipples are of even more frequent occurrence in boys than in girls. He makes the following record. In one hundred and four females there were five cases, or four and four-fifths per cent., of the abnormality, and in two hundred and seven males there were nineteen cases, or nine and one-tenth per cent. Leichtenstern collected from literature ninety-two cases: of these there were twenty-two males and seventy females. Of the thirteen cases observed by himself there were nine males and four females.

The usual situation of supernumerary nipples is below the level of the normal nipple and nearer the median line. When the abnormality is single, it is in the majority of instances found on the left side: the explanation of this is not well made out, but it is interesting in this connection to note the fact that it is the left breast which is, as a rule, more developed than the right. Hyrtl accounts for this latter condition on the ground that the left breast is commonly more used during lactation than the right, because of the greater facility with which the child is held upon the left arm, allowing

<sup>1</sup> Ueber das Vorkommen und die Bedeutung supernumerärer (accessorischer) Brüste und Brustwarzen, von Prof. Leichtenstern in Tübingen, Virchow's Archiv, 1878, Part II., vol. lxxiii. p. 222.

<sup>2</sup> On Supernumerary Nipples and Mammae, with an Account of Sixty-Five Instances observed, by J. Mitchell Bruce, A.M., M.D., etc., Journal of Anatomy and Physiology, 1879, vol. xiii.

<sup>3</sup> On a Case of Secretion of Milk from the Right Axilla, by Charles J. Hare, M.D., etc., Lancet, 1860, vol. ii.

the right to remain free: this is an illustration of what Darwin would style the "inherited effect of use." On the other hand, when there is unilateral amazia, or when with the normal number of breasts one is less fully developed than the other, the anomaly in either case, according to Leichtenstern, is on the right side. When supernumerary glands or nipples appear *above* the normal, they are outward as well as upward; but their presence in this situation is extremely rare (four cases, according to Dr. J. Mitchell Bruce).

Four is the abnormal number of glands or nipples most common; there may be three, still more rarely five, and Alexander<sup>1</sup> records a case of six nipples.

The *axilla* is one of the rarer sites of this anomaly, Leichtenstern recording five such cases and Bruce none. Such a gland may have a nipple,<sup>2</sup> or there may be a minute orifice not larger than one of the sweat-ducts (as in the case already noted as reported by Dr. Hare), or, as witnessed of course only in adult life, the milk may exude from several minute orifices,<sup>3</sup> in which respect these glands resemble the axillary glands of the monotremata. Usually the supernumerary glands are entirely separate from the gland proper, but exceptionally they appear to be prolongations of the mammary gland, being connected with it by a cord. Such a case was observed by M. Notta.<sup>4</sup> In fifteen post-mortem examinations M. Notta found only one case in which there was an axillary prolongation of the breast in the shape of a cord.

Leichtenstern denies the possibility of the presence of supernumerary breasts and nipples upon the abdomen, but Bruce claims that in more than one instance observed by himself the abdominal wall was the seat of the abnormality. Other locations, according to Leichtenstern, are the back (two instances), the acromion (one instance), and the outer side of the thigh (one case).

J. Bland Sutton<sup>5</sup> quotes from Ahfeld's "*Missbildung des Menschen*" a case of supernumerary mammæ upon the labium majus. Barth,<sup>6</sup> of Berlin, tells of a girl who while under treatment for another trouble asked to have a wart removed from her face. This growth, of which a detailed account is given, was situated just below the origin of the lobe of the right ear, and was congenital. It was surrounded by an areola of pigment, and it increased in size during menstruation. After removal it was exhibited

<sup>1</sup> Human Retrogression, by E. W. Alexander, etc., Medical Times and Gazette, July 21, 1885, p. 71.

<sup>2</sup> As in a case reported by S. A. Brown, M.D., of Sioux Falls, Dakota, in *Northwestern Lancet*, St. Paul, April 1, 1888. See also *Lancet*, 1846, vol. ii. p. 227.

<sup>3</sup> *Nashville Journal of Medicine and Surgery*, 1883, vol. xxxi. p. 195, Lacteal Cyst in Axilla, by H. L. Turney, M.D.

<sup>4</sup> *Medical Times and Gazette*, 1882, vol. i. p. 311.

<sup>5</sup> *Supernumerary Mammæ and Nipples in Man, Monkeys, etc.*, by J. Bland Sutton, F.R.C.S., etc., *American Journal of the Medical Sciences*, N. S., vol. xcvii. (January to June, 1889) p. 247.

<sup>6</sup> *Virehow's Archiv*, Bd. cxii. S. 569.



before dissection to many physicians, who declared it to be a nipple, and microscopic study confirmed this opinion.

Bruce gives a critical analysis of the several cases seen by himself with reference to the degree of development of the gland, the areola, the number of hair-follicles, etc., but it is only necessary to say that the supernumerary gland is usually much smaller than that in the normal situation, and that in the cases reported all grades of development of the nipple have been noted, from those doubtful cases the real nature of which it is difficult to determine unless lactation supervenes, up to the fully-developed and destined-to-be-functionally-active papilla with its well-marked areola.

There is a deformity which in adult life interferes with the performance of its function by the breast, and which may be traced to embryonic development and may show itself even when there are the normal number of breasts. According to Leichtenstern, when the human embryo is seven and a half centimetres in length a single furrow appears in the superficial layer of the skin, and at this early stage in the life of the embryo there exists neither areola nor nipple, nor are milk-ducts present. The milk-ducts (according to the same authority) when first observed in the embryo are ten centimetres long, appearing later in communication with the pre-formed papillæ which out of the original furrow in the skin have gradually been elevated. If the development is arrested, so that the embryonal skin-furrow does not rise into a complete papilla, then in the adult the nipple retains its original embryonic form, appearing as a "quite low prominence, superficially flattened, with a linear cleft in the middle like an os uteri."

There are very few cases in which heredity can be traced. Leichtenstern could trace inheritance in none of the cases observed by himself and in only seven of those recorded in literature. Among the latter is the case in which a woman who had three mammary glands, one on the left and two on the right side of the chest, bore a daughter who also had three mammae, two in the normal situation, and one, well formed, upon the outer side of the left thigh, a few inches below the great trochanter; this third mamma during childhood was thought to be a mother's mark, but in adult life it, in common with the other two glands, furnished an abundant supply of milk. This is the famous case so often misquoted as a case of inguinal mammary gland.

Alexander (already referred to) tells of a mother and several children all of whom, except one brother, possessed supernumerary pectoral nipples.

Amastia is exceedingly rare. An interesting case of absence of one breast is reported by Paull.<sup>1</sup> In this case the mother became acquainted with the absence of the left breast in the person of her child about three weeks after its birth, the nurse being loath to inform her before. The circumstance was then told to her surgeon, who gave it as his opinion that the

<sup>1</sup> Total Absence of Left Mammary Gland from Non-Development, by Frederic Paull, M.R.C.S., in a letter to the *Lancet*, 1862, vol. i.

breast might be developed at the age of puberty. The mother attributed the defect to her having been frightened during the third month of pregnancy by a woman who called at the door and exposed marks left by the removal of the left breast for cancer. Since it has been stated that cases of partial or complete absence of one or both breasts are usually associated with some other developmental defect, it is interesting to follow the subsequent history of this infant. She was attended in her first confinement (showing activity of the sexual organs) at the age of twenty-two. The writer states, "On examining the case I could not find the slightest trace of the [left] gland, the ribs being in fact less covered than usual, in consequence of the imperfect development of the pectoral muscle. A small pimple represented the nipple. During her pregnancy this rudimentary nipple had increased in size and had become very painful. With the exception of a slight narrowness of the chest, she was well formed."

Marandel<sup>1</sup> observed a case of absence of one breast, and Lousier<sup>2</sup> mentions the same deformity in a woman and her daughter. A most interesting case of the entire absence of both breasts, with its accompanying congenital defects, in a boy three and a half years old, is reported by Hutchinison.<sup>3</sup> He had no nipples, and their sites were occupied by little patches of scar. Nothing like a mammary gland could be traced.

Leichtenstern believes that human polymastia and polythelia may be explained as an example of retrogression, and ascribes to every man the latent tendency to produce more than two breasts. While Darwin<sup>4</sup> admits that this theory is greatly weakened by the appearance of supernumerary breasts in unusual situations (such as the back), Leichtenstern says that such exceptions "probably show retrogression to still more primitive ancestors." If we accept the view, which according to Handyside<sup>5</sup> was first brought forward by Laycock, that a mamma is simply an aggregation of highly-specialized sebaceous glands, it is less difficult to understand their appearance in various parts of the body where nutrition is especially active, such as the axilla.

Dr. J. Bland Sutton, in the interesting article already referred to, after a careful analysis of the facts, seems to be justified in his conclusion, which is as follows: accessory mammae may arise in three different ways,—viz., (1) by atavism, (2) as "sports," and (3), very rarely, by dichotomy.

The writer wishes to express her thanks to Dr. Mary Fisher for valuable assistance in looking up the literature of this subject.

<sup>1</sup> Dictionnaire des Sciences Médicales, xxx. 378.

<sup>2</sup> Dissertation sur Lactation.

<sup>3</sup> Congenital Absence of Hair and Mammary Glands, with Atrophic Condition of the Skin and its Appendages, in a Boy whose Mother had been almost wholly bald from Alopecia Areata from the Age of Six, by Jonathan Hutchinson, F.R.S., etc., *Medico-Chirurgical Transactions*, London, vol. lxxix. p. 474.

<sup>4</sup> *Descent of Man*, 1871, vol. i. p. 120.

<sup>5</sup> *Journal of Anatomy and Physiology*, November, 1872.

# DISEASES OF THE BLOOD AND BLOOD- MAKING APPARATUS.\*

By J. P. CROZER GRIFFITH, M.D.

DISEASES of the blood and blood-making apparatus constitute a subject so extended and of such scientific importance that the limits of the present article necessitate a discussion of those matters chiefly which possess practical value, and with special reference to features peculiar to the age of childhood.

The characteristics of the blood in children differ but little from those of the blood in adults. In the latter, as in the former, the blood consists of a nearly colorless, alkaline fluid—the plasma—and of corpuscular elements of various forms.

It is usually estimated as equalling  $\frac{1}{13}$  of the total body-weight. In children its relative weight is probably somewhat less ( $\frac{1}{19.5}$ , Weleker),<sup>1</sup> though in the newly-born it is temporarily rather greater. The total weight of the corpuscular elements in adults is estimated by Robin<sup>2</sup> to be about 45 per cent. and that of the plasma 55 per cent. of the whole weight of the blood. The specific gravity is generally stated to be somewhat lower in children than in adults (1045–49 : 1055, Denis),<sup>1</sup> owing to a smaller proportion of solid constituents. This does not, however, apply to the newly-born, in whom there is a specific gravity of 1066, according to Keating and Edwards,<sup>3</sup> and to Jones,<sup>4</sup> who has made careful studies on this subject, finding also at the end of the second week a sudden fall in the specific gravity. The high specific gravity is due to a decided excess in the amount of hæmoglobin. This is the opinion most widely held. The recent researches of Scherenziss,<sup>5</sup> however, lead to a different conclusion,—namely, that the blood of the newly-born is of a lower specific gravity than that of the adult, being defi-

\* It has been impossible to place this article in vol. ii., where it belongs, as Dr. Griffith was asked to undertake its preparation at a late date.—EDITOR.

<sup>1</sup> Vierordt, in Gerhardt's Handb. d. Kinderkr., 1877, i.

<sup>2</sup> Dalton, Human Physiology, 1875, p. 243.

<sup>3</sup> Archives of Pediatrics, 1887.

<sup>4</sup> Journal of Physiology, 1887.

<sup>5</sup> Currier, Ann. Univ. Med. Sci., 1890, ii. L.

cient in hæmoglobin, though rich in stroma. Krüger,<sup>1</sup> too, believes that there is less hæmoglobin in the blood at birth than a short time later. According to the investigations of Leichtenstern,<sup>2</sup> the amount of hæmoglobin is greatest at or soon after birth, and is least from the middle of the first year to the age of five years, when it again begins to increase. The diminution in hæmoglobin takes place even within the first two weeks of life.

The statements regarding the fibrin in the blood of children are conflicting. Of recent writers, Krüger<sup>1</sup> says that the quantity at birth is decidedly diminished, while Silbermann<sup>3</sup> concludes that the fibrin-ferment is increased.

The plasma consists of 90 per cent. water, and contains, besides the corpuscles, albumen; fibrin-forming substance; salts, especially sodium chloride; traces of fat; nitrogenous bodies in small amount, such as urea, uric acid, hypoxanthin, and creatin; traces of certain extractives, as cholesterol, lecithin, sugar, and lactic acid; and gases. The amount of albumen and of salts is generally considered to be diminished in the blood of children, though Scherenziss<sup>4</sup> claims that in the new-born there is an increase of salts.

The corpuscular elements are of four forms: 1. The blood-plaques of Bizzozero, or hæmatoblasts of Hayem. 2. The nucleated red blood-corpuscles. 3. The ordinary red blood-corpuscles, or erythrocytes. 4. The white blood-cells, or leucocytes.

1. The first consist of colorless, minute, homogeneous or finely-granular, disk-like bodies, measuring from 1.5 to 3.5 micro-millimetres,<sup>5</sup> occurring isolated, or frequently agglomerated into the so-called Schultze's granule-masses. Their origin and function are still subjects of much discussion, but they are supposed to bear some part in the production of fibrin and the formation of clots.<sup>6</sup> They are by most observers considered to be independent bodies; but in an elaborate paper recently published by Löwit<sup>7</sup> it is claimed that they are only the products of retrograde metamorphosis, the result of a destruction of the white blood-cells or of a precipitation from the plasma. There are probably 250,000 to 300,000 of them in the cubic millimetre of adult blood, but in infants and young children their number may likely be doubled.<sup>8</sup> Cadet,<sup>8</sup> however, found that the number was decreased in the new-born, as twenty-one children whom he examined exhibited an average of only 171,000 per cubic millimetre.

2. The nucleated red blood-cells are found normally in the red marrow, and are probably intermediate forms between the marrow-cells and the red

<sup>1</sup> *Jahrb. f. Kinderheilk.*, 1888, Bd. xxvii. H. 4.

<sup>2</sup> Vierordt, in *Gerhardt's Handb. d. Kinderkr.*, 1877, I.

<sup>3</sup> *Jahrb. f. Kinderheilk.*, 1887.

<sup>4</sup> *Ann. Univ. Med. Sci.*, 1890, II. L.

<sup>5</sup> Osler, *Medical News*, April 3, 10, 17, 1886.

<sup>6</sup> For a full discussion, with references, see Osler, *loc. cit.*; also Hayem, *Du Sang*, 1889.

<sup>7</sup> Henry, *Ann. Univ. Med. Sci.*, 1890, ii. E; from Virchow's *Archiv*, September, 1889.

<sup>8</sup> Hayem, *loc. cit.*

blood-corpuseles, and, though they are not found in the blood of healthy adults, they are present, according to Ehrlich,<sup>1</sup> in all varieties of anæmia. They occur in that of the fœtus and the young child up to two or three years of age. They consist of distinctly colored discoid bodies, somewhat larger than the ordinary red blood-cells, and containing one or more nuclei.

3. The red blood-cells form by far the largest portion of the corpuscular elements of the blood, and offer much the greatest interest from a practical stand-point. They are pale-yellow, circular, bi-concave disks, without nuclei, and consist of a stroma colored by hæmoglobin. They constitute the means by which oxygen is carried to the tissues. In the adult they vary but little in their size, which is about  $\frac{1}{3200}$  inch, or, according to Hayem,<sup>2</sup> 7.5 micro-millimetres. The number found in a cubic millimetre of blood varies considerably even in health, but averages 5,000,000 in men and 4,500,000 in women. Flexible and elastic and easily changing their shape under pressure, they at once resume this under normal conditions when the pressure is removed.

The number of red blood-cells in the newly-born is relatively increased,<sup>3</sup> but as the child grows older it gradually falls below normal. Silbermann<sup>4</sup> calls attention to the varying size of the red corpuseles in the newly-born, and to the occurrence of "shadows" (*schatten*), or pale corpuseles deprived of their hæmoglobin.

4. The white blood-cells, colorless corpuseles, or leucocytes are masses of finely-granular protoplasm, exhibiting amœboid movements, containing one or more nuclei, and measuring about  $\frac{1}{2500}$  inch in diameter. They bear an important part in inflammatory processes, and have also been claimed by Metschnikoff to have a destructive action upon bacteria, preventing their spread in the tissues. The average number present in a cubic millimetre is from 8000 to 15,000. Their relative number compared with that of the red blood-cells in adults varies, as a rule, from 1 : 350 to 1 : 600-700 (1 : 750, Reinecke),<sup>5</sup> though a decided increase of the number of the white blood-cells over this may exist without constituting any indication of illness.

The blood of children contains normally a larger proportion of leucocytes than does that of adults; the ratio being 1 : 135 up to 1 : 210 from the age of twelve hours up to that of one hundred and fifty days,<sup>6</sup> or, according to Moleschott, an average of 1 : 256 from the age of two and a half up to that of twelve years. Children at the breast possess a greater percentage of leucocytes than do those fed on cow's milk (Demme).

The origin of the red and white blood-cells is not even yet definitely

<sup>1</sup> Berlin. Klin. Wochenschr., 1880, 405.

<sup>2</sup> Du Sang, 1889.

<sup>3</sup> Lepine, Comptes-Rend. d. l. Soc. d. Biol., 1876; Demme, Jahrb. f. Kinderheilk., 1882, 357; Hayem, loc. cit.; Henry, Archives of Medicine, 1883, x. 97.

<sup>4</sup> Jahrb. f. Kinderheilk., 1887.

<sup>5</sup> Fortschr. d. Med., 1889, vii. 408.

<sup>6</sup> Demme, loc. cit.

understood. Briefly stated, it would seem almost certain that the white cells are formed in the lymphatic glands and other similar adenoid tissue, while the red cells are developed from the leucocytes, from the nucleated red blood-corpucles in the bone-marrow, or from the hæmatoblasts.

In the study of the diseases of the blood and blood-making apparatus, it becomes all-important to understand the most practically useful scientific methods for its examination. Much may be learned from simply viewing with the microscope a drop of blood upon a glass slip. A rough determination can be made of the presence of an increase in the number of the white blood-cells; and the color, shape, and arrangement of the red corpuscles can be noticed, as well as the number of hæmatoblasts and the occurrence of nucleated red blood-cells or of parasites. But for the thorough study of the condition of the blood in disease more exact methods must also be used.

For practical clinical purposes the two important matters to be determined by the employment of special apparatus are the percentage of hæmoglobin and the absolute and relative number of the white and red blood-cells. For the first we may employ the hæmoglobinometer of Gowers or the instrument of Fleischl.

The apparatus of Gowers, shown in Fig. 1, consists simply of a small guarded lancet, a twenty-cubic-millimetre capillary glass pipette, a small

FIG. 1.

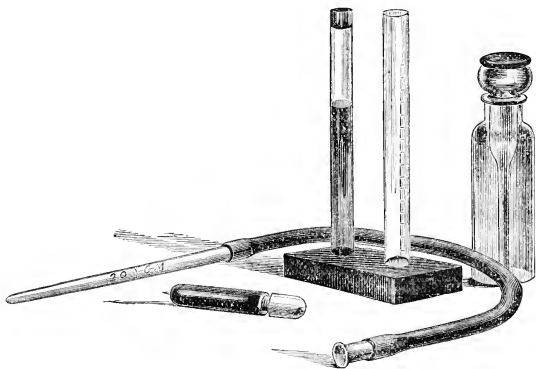

bottle with pipette-stopper, and two narrow glass tubes of the same size, one filled with a transparent colored matter which is regarded as the standard, the other graduated with an ascending scale of percentages from 10 to 120. In using this apparatus a few drops of water are first put into the graduated tube, to prevent coagulation of the blood; the finger is then pricked with the lancet, and twenty cubic millimetres of blood are drawn into the pipette and blown into the tube. Water is now carefully added from the bottle, with frequent shakings of the tube, until the color of the

diluted blood, both by transmitted light and when held against a white background, is the same as that of the standard. The percentage of hæmoglobin is now read off and recorded. It is evident that the richer the blood is in hæmoglobin the more water will be required to produce a dilution of a color corresponding to that of the standard, and the higher the indicated percentage will be.

Gowers's apparatus is to be recommended for its simplicity as well as on account of accuracy quite sufficient for clinical purposes. A great disadvantage sometimes attending its use lies in the fact that a rather large drop of blood is required to fill the pipette, and that it is sometimes difficult to obtain this in cases of extreme anæmia. Fleischl's hæmometer (Fig. 2) is

FIG. 2.

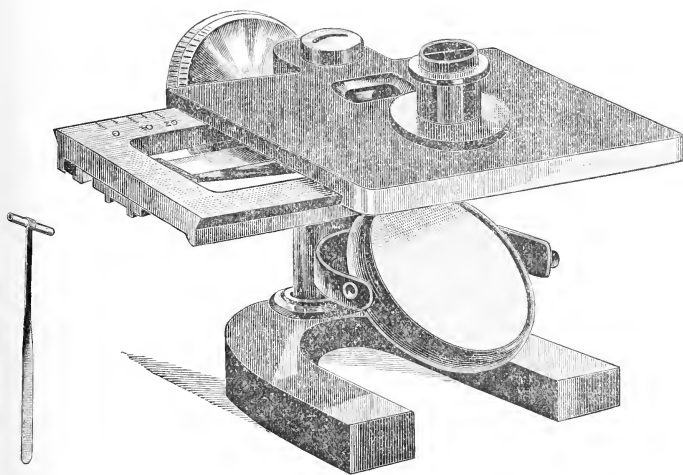

as accurate and quite as convenient as the instrument of Gowers, and, moreover, requires but a very small amount of blood. The apparatus consists of a small metal table with an opening in the centre, and under this a reflector made of plaster of Paris. The opening is occupied by a small well having a glass bottom and divided into two equal compartments. The most important part of the apparatus consists of a wedge-shaped piece of ruby glass, the more intense color of whose thicker end shades off gradually into the nearly colorless thinner end. The glass is mounted in a carriage moving under the table by a rack and pinion, and on a portion of the carriage, as seen in the illustration, a percentage scale is engraved, the "0" of which is at the same end with the thinner portion of the glass wedge. One-half of the well receives simply the white light from the plaster-of-Paris reflector, while the other rests over the ruby glass and obtains light through it. A small pipette and several capillary glass tubes about three-

eighths of an inch in length and mounted on slender metal handles accompany the instrument. The tubes are carefully made of such a capacity that the blood contained in one of them, when of the normal richness in hæmoglobin, and when diluted with the proper amount of water in the well, will indicate a percentage of 100 on the scale. To use the instrument, one end of a capillary tube is lowered carefully upon a drop of blood drawn from the finger, whereupon the whole of it immediately becomes filled. The blood is now washed from the tube into one of the compartments of the well, by blowing water through the tube from the pipette. The compartments, which previously contained some water, are now completed and equally filled with it, and the well so placed that the side containing blood receives white light, while the other receives light through the ruby glass. The glass is now moved by the rack and pinion until the intensity of the color in the two compartments is the same, and the percentage is then read off through the small opening behind the well.

I have made comparative tests with these two instruments, and find the readings to be practically the same. Sioling<sup>1</sup> has made careful comparative estimates of the instruments of Gowers, Hayem, Malassez, Bizzozero, and Fleischl, and finds that the latter combines the greatest accuracy with simplicity of method. It should be noted that Fleischl's hæmometer can be used only with artificial light and Gowers's instrument only with daylight. A special tube has been devised to permit the use of the latter at night-time.

For the estimation of the number of red and of white blood-cells several hæmacytometers have been devised, that of Thoma-Zeiss (Fig. 3) being one

FIG. 3.

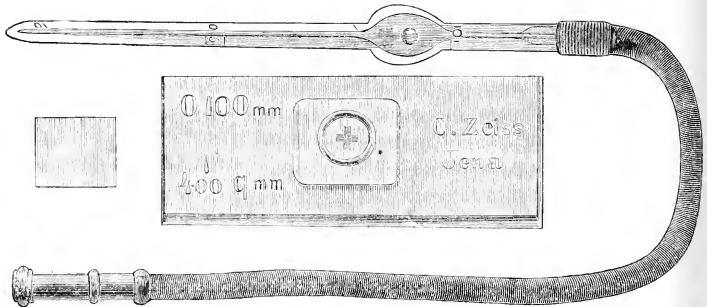

of the most satisfactory. One portion of this instrument is the "Potain's mélangeur," a glass capillary tube with the lower portion graduated to hold  $\frac{1}{2}$  and 1 cubic millimetre, and the upper portion widened into a bulbous enlargement of a capacity of 100 cubic millimetres, and containing within

<sup>1</sup> Ann. Univ. Med. Sci., 1888, i. 407.



its cavity a small, freely movable glass ball to aid in mixing the blood. The second part of the apparatus is designed for the counting of the blood-corpuscles, and consists of a glass slide on which is constructed a cell exactly  $\frac{1}{10}$  millimetre in depth. The periphery of the cell is surrounded by a circular gutter, to prevent the fluid from finding its way between the cover-glass and the slide, as in this event the correctness of the estimation would be vitiated. The bottom of the cell is ruled with intersecting lines forming a large number of squares each having an area of  $\frac{1}{400}$  square millimetre. The squares are arranged in larger squares outlined by double lines, and containing 25 of the smaller ones (Fig. 4). A carefully-ground cover-glass covers the cell. An easy calculation shows that the cubic space over each small square, between the cover and the bottom of the cell, equals  $\frac{1}{4000}$  cubic millimetre.

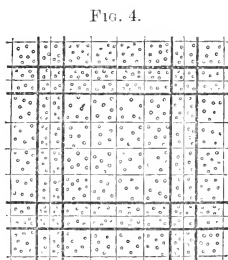

After Jaksch.

To use the instrument the finger of the patient is pricked, and half a cubic millimetre of blood carefully drawn into the pipette. The point of this is quickly freed from all excess of blood, and plunged into a  $\frac{1}{3}$  per cent. salt solution, or a 5-per-cent. solution of sulphate of sodium, and the liquid drawn into the bulb until it reaches the mark "101." Meanwhile the tube is constantly revolved between the fingers, in order that the movements of the glass bead may facilitate the thorough dilution of the blood. The mixing being complete, the excess of salt solution remaining in the capillary portion of the *mélangeur* is blown out, and a drop of the diluted blood then placed in the centre of the cell. The cover-glass is now applied, care being taken that no fluid passes between it and the slide, and that no bubbles be present. It is now pressed firmly against the slide until Newton's color rings appear. Lyon and Thoma<sup>1</sup> lay great stress upon this point. Should the rings not develop, it is evidence that there is not good apposition between the slide and the cover; and both must be carefully cleaned and a fresh drop obtained from the *mélangeur*. After allowing about five minutes for the corpuscles to settle, the slide is examined with the microscope under a lens of rather low power, to see that they are evenly distributed, and is then studied with a power of from two hundred to four hundred diameters.

To calculate the number of corpuscles in a cubic millimetre, those are counted which are contained in a series—say 25—of small squares; the corpuscles which touch the upper and left-hand border lines of any given square being considered as belonging to it. A simple equation gives the result,—viz.:

<sup>1</sup> Virchow's Archiv, lxxxiv. 131.

Number of times the volume of fluid over one square is contained in a cubic millimetre  $\times$  Dilution  $\times$  Total number corpuscles counted

Total number of corpuscles in a cubic millimetre of blood.

Number of squares counted

=

The capacity of the space over each square is, as already stated,  $\frac{1}{4000}$  cubic millimetre. Supposing, then, that 25 squares be counted, and that, say, 150 corpuscles be found, the equation would be expressed in figures as follows :

$$\frac{4000 \times 200 \times 150}{25} = 4,800,000$$

As the first three figures of the equation always reduce themselves by cancellation to 32,000, it is an easy process simply to multiply the number of corpuscles in 25 squares by this factor in order to obtain the desired result. Some slips are ruled in squares containing only 16 smaller squares. In this case the factor becomes 50,000. In cases where still greater accuracy is desired, it is better to count many more than 25 squares; and in patients with extreme anaemia one cubic millimetre of blood should be employed instead of half a cubic millimetre.

Although special forms of apparatus have been devised for the determination of the number of leucocytes in a cubic millimetre, the method just described for the enumeration of the red corpuscles may be satisfactorily employed. It is necessary, however, to count a large number of squares in order to attain any degree of accuracy in the result. The fluid used for diluting the blood should be a  $\frac{1}{3}$  per cent. solution of acetic acid, as recommended by Thoma,<sup>1</sup> or some solution similar to that suggested by Toison.<sup>2</sup> This consists of distilled water, 160 grammes; glycerin, 30 cubic centimetres; sulphate of soda, 8 grammes; chloride of soda, 1 gramme; methyl violet, 0.025 gramme. The solution should be diluted with an equal volume of water before using. The former dissolves the red cells, allowing only the white to appear; the latter differentiates the leucocytes by staining them.

Various other instruments are sometimes employed in studying the blood, but for purely clinical purposes are not needed or require too great a degree of skill. Among these are the spectroscope, the hamato-spectroscope of Henoeh, and the chromo-cytometer of Bizzozero.

Before taking up the consideration of the more generally recognized diseases of the blood and blood-making apparatus, some attention must be directed to certain of the altered blood-conditions, perhaps more properly viewed as symptoms.

**I. Changes in the Morphotic Elements.**—A. *Leucocytosis*.—By this title may be designated an increase, usually temporary, in the number of

<sup>1</sup> Virchow's Archiv, lxxxvii. 201.

<sup>2</sup> Jour. des Sci. Méd. de Lille, February, 1885.

white blood-cells. The ratio of the white to the red cells in this condition may equal 1 : 100 or even 1 : 50, Henry<sup>1</sup> giving the latter figure as its limits. V. Jaksch<sup>2</sup> even claims that the ratio may in children reach 1 : 20 or 1 : 12 without constituting a true leukaemia. In children, as in adults, leucocytosis may be physiological or pathological. The first is witnessed from one to two hours after a full meal, but does not reach the degree seen in the second form. Demme<sup>3</sup> has made careful observations on physiological leucocytosis in infants, and has found a marked increase in the number of leucocytes even within twenty-five or thirty minutes after nursing. Pathological leucocytosis occurs in acute inflammatory diseases, suppurative processes, chronic cachectic conditions, as tuberculosis and cancer, and in many forms of anæmia. Limbeck<sup>4</sup> claims that inflammatory leucocytosis is witnessed only in those diseases in which there exists an exudation somewhere in the body; while in infectious diseases, in which there is none, as intermittent and typhoid fevers, there is no increase in the number of white blood-cells, and in the latter disease even a diminution. Virchow says that all conditions in which the lymphatic glands are involved produce leucocytosis.

Leucocytosis is most apt to be confounded with leukaemia, especially if amyloid spleen or carcinoma in the splenic region be present.

B. *Poikilocytosis*.—This term was first employed by Quincke<sup>5</sup> to indicate a tendency of the red blood-cells to assume variously-distorted shapes, such, for example, as seen in Plate I, Fig. 1. Amoeboid processes have also been described.<sup>6</sup> The condition has been supposed to be characteristic of pernicious anæmia, but is not always present in this disease, and may be witnessed in any disorder which is accompanied by marked changes in the blood. Jaksch<sup>7</sup> reports its occurrence in chlorosis, severe anæmias of all kinds, cancer, amyloid degeneration, and leukaemia; and I have rarely seen it to greater advantage than upon one occasion in a severe case of post-hæmorrhagic anæmia.

C. *Microcythæmia*.—In microcythæmia, as described by Vanlair and Masius,<sup>8</sup> the blood contains a small or a large number of minute red, globular or discoid bodies containing hæmoglobin and measuring from  $1\frac{1}{2}$  to 5 micro-millimetres in diameter. With them are often found red blood-cells of usually large size (macrocytes, megalocytes) but of normal appearance in other respects. These measure from  $8\frac{1}{2}$  up to even 15 micro-millimetres in diameter. The diagnostic signification and mode of origin of the

<sup>1</sup> Anæmia, 1887, p. 97.

<sup>2</sup> Wien. Klin. Wochenschr., May 30, 1889; in Ann. Univ. Med. Sci., 1890, vol. ii. J.

<sup>3</sup> Jahrb. f. Kinderheilk., 1882.

<sup>4</sup> Münch. Med. Wochenschr., January 14, 1890.

<sup>5</sup> Deutsches Archiv f. Klin. Med., 1877, xx. 1, and 1880, xxv. 577.

<sup>6</sup> Pilz, Eichhorst, Spec. Path. u. Therap., 1885, iv. 37.

<sup>7</sup> Klin. Diag., 1887, p. 19.

<sup>8</sup> Bull. de l'Acad. Roy. Méd. de Belgique, ser. iii. tom. v.

microcytes are not definitely ascertained. They are probably either young corpuscles in process of growth, or the remains of corpuscles which have disintegrated. Gräber<sup>1</sup> maintains that neither microcytes nor poikilocytes are present in the circulation, but are the result of changes occurring after the blood is drawn from the body.

It would appear that they are most commonly increased in anæmia, of whatever variety. Osler<sup>2</sup> believes that they are most constantly and abundantly present in the so-called primary anæmias, but especially in pernicious anæmia. They are also found in infectious and toxic diseases.

In the newly-born microcytes are normally found.<sup>3</sup> Demme<sup>4</sup> has found them so numerous in sucklings that the enumeration of the red blood-cells was rendered difficult. He estimates that there are 350,000 to 420,000 in the cubic millimetre at the age of from two to eight days.

D. *Melanæmia*.—This condition, which Pilliet<sup>5</sup> considers more common than is generally supposed, was first described by Meckel<sup>6</sup> in 1847. It is to be regarded as a symptom of melanosis of the organs rather than as a primary affection of the blood, and consists in the occurrence in the blood of granular pigment, generally black, but sometimes brown or yellow. (See Plate I., Fig. 2.) It is either free in the plasma or, more usually, enclosed in the white blood-cells or in other more spindle-shaped or irregularly round cells derived probably from the endothelium of the liver or spleen. The free pigment-granules may be molecular or may exceed the size of the blood-cells. They are sometimes combined with an albuminous matrix into aggregations of various sizes and forms.

The cause of melanæmia is almost invariably malarial poisoning, generally of a severe type; and the pigment is produced by the transformation of hæmoglobin into melanin, through an excessive destruction of the red blood-cells. This destruction takes place either within the blood itself or, more probably, within the spleen, the red bone-marrow, the liver, and the lymphatic glands.

Pigment-granules have also been found in the blood of relapsing fever, and rarely in Addison's disease and in melanotic sarcoma. Soyka<sup>7</sup> has reported melanæmia in a case of extreme anthracosis, in which dark granules of carbon circulated in the blood, and were deposited in the spleen, kidneys, and liver.

II. **Chemical Changes in the Blood.**—To these, other than as already described, only passing reference lies within the province of this article.

*Uræmia*, which is probably the most important of them, is the term

---

<sup>1</sup> Fortschr. d. Med., 1887.

<sup>2</sup> Medical News, April 3, 10, 17, 1886.

<sup>3</sup> Osler, loc. cit.

<sup>4</sup> Jahrb. f. Kinderh., 1882, 357.

<sup>5</sup> La Trib. Méd., July 4, 1889, in Ann. Univ. Med. Sci., vol. ii. E, 1890.

<sup>6</sup> Neuman, Virchow's Archiv, May, 1889.

<sup>7</sup> Virchow's Archiv, lxxxiv.

PLATE I

FIG. 1.

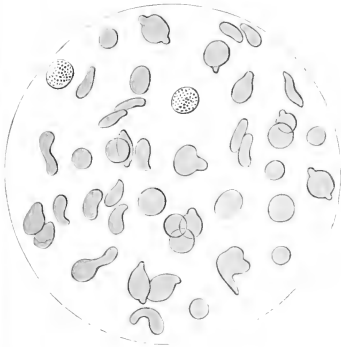

POIKILOCYTOSIS.

FIG. 2.

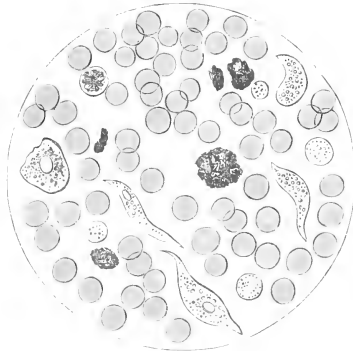

MELANEMIA.

FIG. 3.

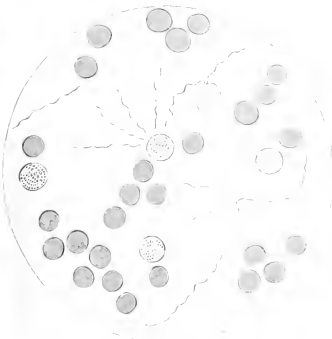

BLOOD IN RELAPSING FEVER, SHOWING THE SPIRILLUM.

FIG. 4.



BLOOD IN LEUCEMIA.



employed to indicate the presence in the circulation of certain substances peculiar to the urine. Which of these is the exciting cause of the symptoms cannot as yet be determined.

*Ammonæmia* is a condition but little understood. It is supposed to be a state of the blood caused by the absorption of ammonia and probably of alkaloidal substances or other products of decomposition from the diseased mucous lining of the bladder.

*Acetonæmia* describes that condition in which the blood is laden with acetone. It has been carefully studied by Von Mikulicz and others. Though most frequently present in diabetical patients, I have seen two instances occurring in other affections,<sup>1</sup> in which the symptoms seemed to be due to acetonæmia. Tuzek<sup>2</sup> reports the occurrence of acetone in the urine, and of symptoms probably due to acetonæmia, in a child of four years, in whom antipyrin had been used for pertussis.

*Cholæmia* denotes the presence in the blood of the constituents of the bile, especially of the biliary acids. These acids appear to be the active toxic agents, retarding the pulse, and even destroying the red blood-cells. By delicate chemical processes small amounts of the biliary acids can be found in the blood in cholæmia.<sup>3</sup> The biliary coloring-matters can be detected more easily.<sup>4</sup>

*Lipæmia* is the term used to indicate the presence of a considerable amount of fat in the blood. The minute fat-globules occur free in the plasma, and frequently are contained within the white blood-cells also. The condition develops physiologically to a slight degree during digestion. It has also been witnessed<sup>5</sup> in chronic nephritis, diabetes, injuries of the bone-marrow, and chronic alcoholism. I have myself seen in a case of ulcerative endocarditis in a male adult an exquisite example of a form of lipæmia in which fat in large quantities was present within the greatly enlarged white blood-cells, although there was none free in the plasma. The somewhat diagrammatic illustration of these is taken from a photograph of the blood of this patient, made for me by Dr. George A. Piersol. (See Fig. 5.)

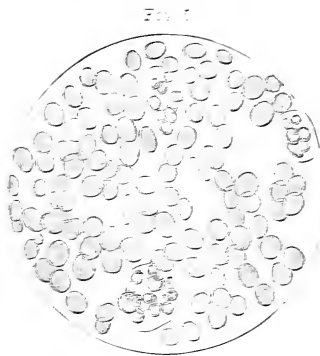

*Hæmoglobinæmia* is that condition of the blood in which hæmoglobin is

<sup>1</sup> Ueber Acetonurie u. Diaceturie. Berlin, 1885.

<sup>2</sup> Medical News, October 3, 1885.

<sup>3</sup> Berlin. Klin. Wochenschr., April 29, 1889.

<sup>4</sup> Hoppe-Seyler, Handbuch der phys. u. path.-chem. Analyse, 1885.

<sup>5</sup> Von Jaksch. Klin. Diagnostik, 1887, 45.

circulating free in the plasma. If a certain amount of blood be removed from the body—as by wet-cupping—and allowed to stand for some hours, the fluid above the clot which forms will be transparent but of a red color if it contain free hæmoglobin. In normal blood the serum is transparent and of a yellow color. The presence of hæmoglobinæmia is not by any means always evinced by the occurrence of the hæmoglobinuria. As Ponfick has shown,<sup>1</sup> the liver is able to dispose of a certain amount of the hæmoglobin, converting it into bile-pigment, and producing an unusually rich bile, and feces of a dark-brown color. When the amount of hæmoglobin exceeds this, it passes through the liver and appears in the urine. Silbermann<sup>2</sup> says that there is physiologically a hæmoglobinæmia in the new-born, as shown by the presence of bile in the urine, and by the occurrence of “shadows” (*schatten*) in the blood. The cause of hæmoglobinæmia is any agent operating to produce a destruction of the red blood-cells within the general circulation, such as the intravenous injection of certain substances, as glycerin, water, blood from other animals, or the occurrence of severe attacks of some of the infectious diseases, etc. Infectious hæmoglobinæmia of the newly-born, the so-called Winekel’s disease, is more conveniently discussed as a distinct affection under Diseases of the Blood.

Among other alterations in the chemical constitution of the blood are the presence in it of a large amount of *peptone*, as indicated in some cases by peptonuria; *mellitæmia*, or the presence of increased quantities of sugar, as seen chiefly in diabetes; the development of *methæmoglobin*, resulting from the poisonous action on the blood of such substances as acetanilid, phenacetin, chlorate of potassium, pyrogallie acid, permanganate of potassium, nitrite of amyl, nitrite of potassium, etc. In addition may be mentioned the occurrence of considerable quantities of *uric acid* in the blood of gouty patients, and *lipacidæmia*, signifying blood containing small amounts of fatty acids.

III. *Parasites in the Blood.*—Some of the vegetable parasites present at times in the blood are found much more frequently in other parts of the body. The *Bacillus tuberculosis* has been occasionally seen in it in cases of general miliary tuberculosis, though in very small numbers. Weichselbaum<sup>3</sup> was the first to observe it in this situation. The *Bacillus anthracis* is not infrequently present in the blood, and that of *glanders* and of *typhoid fever* has also been discovered there.

One of the most interesting of the micro-organisms in this connection is the *Spirillum Obermeieri* or *Spirochæte Obermeieri* of relapsing fever, first discovered by Obermeyer.<sup>4</sup> (See Plate I., Fig. 3.) It is generally described as a distinct species, though classified by Sacheroff<sup>5</sup> as only one stage in the

<sup>1</sup> Verhandlung d. Congr. f. innere Med., 1883, ii. 205.

<sup>2</sup> Centralbl. f. Klin. Med., 1887.

<sup>3</sup> Wien. Med. Wochenschr., 1884, xxxiv. 333.

<sup>4</sup> Centralbl. f. d. Med. Wissensch., 1873, xi. 145.

<sup>5</sup> Rev. Scientif., July 6, 1889, quoted by Henry in Ann. Univ. Med. Sci., 1890, vol. ii. E.



development of a large hæmatozoon. The spirillum consists of a very slender spiral filament, from 16 to 40 micro-millimetres in length, which exhibits very active snake-like movements in the direction of its long axis. It can be found in the blood only during the febrile stage of the disease. Even with a lens of low power a certain disturbance may be noticed among the red blood-cells, due to the movements of the parasite. Its structure seems to be entirely homogeneous. It is exceedingly sensitive to and easily killed by different reagents, but may be kept alive for days in blood, or in a one-half per cent. salt solution. A cover-glass preparation of blood containing it may be best stained with fuchsin. For a discussion of relapsing fever, see the article by Curtin in this Encyclopædia.<sup>1</sup>

The peculiar *Plasmodium malarie*, which has awakened so great interest, is fully described, with illustrations, in the article on malaria contributed to this Encyclopædia by Foreheimer.<sup>2</sup> I have repeatedly witnessed its various forms in the blood of malarial patients, and even based a diagnosis upon its presence.

Of animal parasites, the *Filaria sanguinis hominis*, as seen in the blood, is the embryonal form of a nematoid worm. The larva was first discovered by Wucherer<sup>3</sup> in the urine, and afterwards by Lewis<sup>4</sup> in the blood. (Fig. 6.) It is  $\frac{7}{10}$  inch in length and  $\frac{1}{3500}$  inch in thickness, and is provided with a blunt head and a long pointed tail. Mackenzie<sup>5</sup> calculated that from 36,000,000 to 40,000,000 were present in the circulation in his patient at night. They can be found, in fact, only about the time of day during which the patient is at rest in bed.

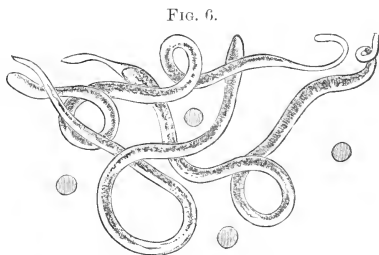

A few red blood-corpuscles are introduced to show relative size of parasites. (After Lewis.)

The parent worm (*Filaria Bancrofti*) is from three to four inches long, and about as thick as a hair. It has been found in the larger lymphatic vessels in a few cases. The embryos may remain a long time in the human body without doing damage, but may finally, by bursting through the blood-vessels, give rise to hæmaturia or chyluria. Though indigenous to the tropics, the parasite has been discovered by Guitéras<sup>6</sup> in the blood of a patient who had never left the United States. It is probable that mosquitoes draw into themselves the larval filaria with the human blood. This then develops within its host, reaches the perfect form, is deposited in water by the insect,

<sup>1</sup> Vol. i. p. 504.

<sup>2</sup> *Ibid.*, p. 825.

<sup>3</sup> *Gazeta Medica da Bahia*, December 5, 1868.

<sup>4</sup> "On a Hæmatozoon inhabiting Human Blood," Calcutta, 1872.

<sup>5</sup> *Trans. Path. Soc. Lond.*, 1882.

<sup>6</sup> *Medical News*, April 10, 1886.

and is ingested by man, to again produce larvæ within him. The parasite exists in children as well as in adults; in fact, the second autopsy made by Lewis was in the case of a young girl of sixteen years.

The *Bilharzia hæmatobia*, or *Distonum hæmatobium*, a trematode worm, was discovered by Bilharz.<sup>1</sup> (Fig. 7.) It is of very frequent occurrence

FIG. 7.

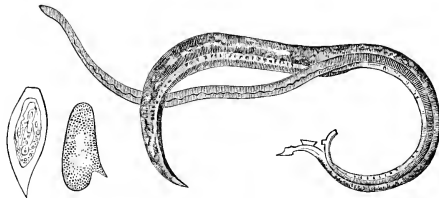

After Leuckart.

in Egypt, and is particularly liable to develop in males, and especially in boys. The male is a thread-like worm about half an inch in length, somewhat flattened, and provided with a channel into which the female is received. The female is thinner, and about three-quarters of an inch long. The parasite is present in the veins of the portal system, especially the small ones of the rectum, bladder, ureter, and pelvis of the kidney. It is not found in the general circulation. The eggs are very numerous in the vessels of the bladder and pelvis of the kidneys, and may usually be observed in the bloody urine.

#### CLASSIFICATION.

The classification of the diseases of the blood and the blood-making organs presents many difficulties. Apart from the constitutional diseases, as already described in vol. i. of this work, and from malignant and surgical affections of the hæmatopoietic system, treated of in vol. ii., the following provisional classification may be made: 1, Plethora; 2, Anæmia of various forms; 3, Addison's disease, which by some writers is included among disorders of the blood-making system; 4, Infectious hæmoglobinæmia of the newly-born (*Hæmoglobinæmia neonatorum infectiosa*),—other forms of hæmoglobinæmia either scarcely meriting the title of distinct diseases or receiving consideration in the department of this Encyclopædia treating of hæmoglobinuria.

<sup>1</sup> Zeitschr. f. Wissensch. Zool., 1853, iv. 59, 72, 454.

## PLETHORA.

Plethora or polyæmia is a condition in which the total amount of blood in the body is persistently in excess of normal; or in which some of its constituents, especially the red blood-cells, are greatly increased in amount, without any diminution in the volume of the blood.

It is the general opinion at the present time that the first of these conditions does not exist except as a transitory affection. The full-blooded appearance usually described as plethoric may be due in some cases to an abnormally large number of red blood-cells in the circulation, but in other instances it probably depends simply on an irregular distribution of the blood. It is certain, in any case, that even this plethoric appearance is of the rarest occurrence in childhood, in which age a tendency to anæmia physiologically obtains. In the newly-born, however, there may probably be immediately after birth a state of absolute plethora, due to the passage of some of the blood from the placenta into the body of the child. Independently of this, the blood at this age exhibits a relative plethora, a poly-cythæmia; being unusually rich in red blood-cells. In one of a series of newly-born infants examined by Henry<sup>1</sup> the number of corpuscles equalled 6,410,000, and in another 5,925,000, per cubic millimetre. Cadet<sup>2</sup> found the mean of his estimates of the red corpuscles of the newly-born to be 5,696,000, the highest figure being 6,920,000; while the average of the results obtained by Demme<sup>3</sup> gave 5,650,000 to 5,860,000 in one cubic millimetre. Hayem<sup>4</sup> has shown that the number depends on the time at which the umbilical cord is tied. Thus, in six children in whom the ligation was made immediately after birth, the average equalled 5,087,000; while in eight others in whose cases it was delayed until all pulsation had ceased, the average was 5,576,000 per cubic millimetre.

This condition of plethora, however, disappears very rapidly, as was shown by the observations of Henry. In the first case quoted above, the number of corpuscles was reduced in twenty-four hours to 5,810,000, and in two days more to 5,680,000.

The term "hydræmic plethora" is sometimes employed, instead of the better title "hydræmia," to express that condition in which the loss of red blood-cells or of albuminous matter has been supplied by water. It does not indicate any actual increase in the total amount of blood in the body.

A relative increase in the number of red blood-cells does not of itself constitute plethora. The amount of fluid in the blood must not be dimin-

---

<sup>1</sup> Archives of Medicine, 1883, x. 97.

<sup>2</sup> Hayem, Du Sang, 1889, p. 179.

<sup>3</sup> Jahrb. f. Kinderheilk., 1882, S. 357.

<sup>4</sup> Du Sang, 1889, p. 179.

ished. If this has occurred and is accompanied by the relative increase in the number of erythrocytes, we have to do rather with an "anhydræmia,"—an inspissation of the blood. Such a condition may be observed whenever the body has suffered a great and sudden loss of fluid, as in cholera.

## ANÆMIA.

Anæmia may be briefly described as a diminution of the amount of blood *in toto*, or of its albuminous material, red blood-cells, or hæmoglobin. The diminution simply of the amount of water in the blood, as seen in cholera, does not constitute anæmia.

Various titles have been employed to define it; as, oligæmia, oligocythæmia, spanæmia, oligochromæmia, etc.

There is perhaps no pathological condition more frequently observed in children. Children, indeed, after the first few days of life become physiologically anæmic; the blood being hydræmic, with hypalbuminosis and oligocythæmia, and a consequent diminution in the amount of hæmoglobin. Then, too, owing to the ease with which the blood, as well as the other tissues of the growing child, is affected by outside causes, there is scarcely any disease to which children are subject which, if long continued, will not produce anæmia; and often this condition is one of the earliest symptoms. It is, therefore, of paramount importance that every case of anæmia in the early years of life be investigated with particular care as to its cause.

I have found the following classification of the anæmias useful for the purposes of study, though our limited knowledge of the physio-pathology of the subject renders any classification only provisional.

Anæmia .	{ Non-cytogenic .	{ Hæmolytic . . .	{ Pernicious anæmia.
			{ Other toxic anæmias.
		{ Oligocythæmic . .	{ Parasitic anæmias (some forms).}
	{ Parasitic anæmias (some forms).}		
	{ Cytogenic . . .	{ Oligochromæmic . .	{ Post-hæmorrhagic anæmia.
			{ Anæmia from loss of albumen.
{ Leucocytic . . . .		{ Chlorosis (?).	{ Anæmia of malnutrition.
	{ Chlorosis.		
	{ Leukæmia . . . .	{ Splenic.	
{ Non-leucocytic . .	{ . . . .	{ Lymphatic.	
		{ Medullary.	
		{ Simple constitutional anæmia.	
{ . . . .	{ . . . .	{ Splenic anæmia.	
		{ Lymphatic anæmia (Hodgkin's disease).	
		{ Pernicious anæmia (?).	

The term cytogenic is used here to indicate those forms of anæmia apparently due to an organic or functional affection of the blood-making

apparatus, non-cytogenic applying to those in which some other cause seems to be the operative one. The terms *primary* and *secondary* should either be avoided altogether, or strictly limited in their application. "Primary" applies to the cytogenic anæmias and indicates a primary disorder of the blood-making apparatus, while "secondary" and "symptomatic" appertain, for the most part, to the non-cytogenic anæmias. In one sense, of course, every anæmia is secondary, being itself a symptom; for, as Hayem forcibly insists,<sup>1</sup> the blood is not to be considered apart from the different parts of the body which exert an influence upon its anatomical constitution. From another point of view every anæmia is cytogenic, in that the blood-making organs do not produce sufficient blood to meet the extra demands made upon them by wasting diseases, hemorrhage, excessive destruction of blood, etc.

With our advancing knowledge it seems to become more probable that there are no sharply-defined distinctions between some, at least, of the different varieties of anæmia. Chlorosis is usually viewed as a distinct variety of anæmia, yet cases have been reported by Henry<sup>2</sup> and by Trechsel<sup>3</sup> in which a transition from chlorosis to pernicious anæmia appeared to have taken place; and Henry<sup>2</sup> asserts that the reverse often occurs. It is extremely doubtful, however, whether these are not instances of chlorosis complicated by pernicious anæmia.

Leukæmia, which is generally considered to be a distinct disease, was claimed by H. C. Wood<sup>4</sup> to be nearly related to or perhaps identical with Hodgkin's disease; while Fleischer and Penzoldt,<sup>5</sup> and quite recently Mosler,<sup>6</sup> have reported cases in which there occurred a transition from the latter to the leukæmic affection. The position of pernicious anæmia pathologically is not even yet exactly determined, while clinically it is certainly nearly allied to some other forms of severe anæmia, and sometimes cannot be distinguished from them during life. Musser,<sup>7</sup> for example, reports a case of pernicious anæmia which would at one period have been more properly designated leukæmia, and cases showing the reverse of this have been published by Litten<sup>8</sup> and Leube and Fleischer.<sup>9</sup> Other authors have shown that many cases which once would have been designated essential or idiopathic pernicious anæmia were really instances of secondary forms due to intestinal parasites, atrophy of the gastric tubules, or some other cause.

---

<sup>1</sup> Du Sang, 1889, p. 613.

<sup>2</sup> Medical News, July 3, 1886.

<sup>3</sup> Rev. Méd. de la Suisse Romande, June 20, 1888.

<sup>4</sup> American Journal of the Medical Sciences, October, 1871.

<sup>5</sup> Deutsches Archiv f. Klin. Med., 1880, xxvi. 368.

<sup>6</sup> Virchow's Archiv, 1888, cxiv. 461.

<sup>7</sup> Proceedings of the Philadelphia County Medical Society, 1885.

<sup>8</sup> Berlin. Klin. Wochenschr., 1877.

<sup>9</sup> Virchow's Archiv, lxxxiii.

## NON-CYTOGENIC ANÆMIAS.

By far the most common forms of anæmia in childhood are those constituting the non-cytogenic group. They may be subdivided into several classes, some of the members of which shade into one another.

The class of hæmolytic anæmias include those forms which are due to a destruction of the blood within the circulation. "Oligocythæmic" expresses the prominent characteristic of all the members of the second class, though it applies equally well to the first. It is used, however, to designate the characteristic difference between these and the single member of the oligochromæmic class, chlorosis.

PERNICIOUS ANÆMIA might well be described as the first of the hæmolytic anæmias, in which division I believe that it belongs. It has, however, usually been regarded as an anæmia due to defective hæmogenesis, and its true nature is even yet determined with so little certainty that I have reserved it for the separate consideration which its importance demands.

OTHER TOXIC ANÆMIAS constitute a somewhat heterologous group of cases, some of which could better be described under other non-cytogenic forms. The poison circulating in the blood and exerting its deleterious action may be either (*a*) produced within the body or (*b*) introduced into it from without.

(*a*) It is probable that the anæmia seen in all prolonged febrile conditions belongs to this class, and that it is due to the direct destroying action on the corpuscles of a chemical poison generated by the pyrexia itself. That this is the only cause of the anæmia of fever is, however, by no means certain, as it is possible that the function of the blood-making organs may be directly interfered with, or that the imperfect absorption of food during fever may produce an anæmia of malnutrition. Gerhardt<sup>1</sup> calls attention to the anæmia sometimes developing in children who are recovering from diphtheria. It is of extreme degree, very rapid in its course, and fatal in a few days; and must be regarded as a peculiar toxic form, as it is too severe to be attributed to fever simply or to inanition.

(*b*) Among the inorganic toxic agents introduced into the body from without may be mentioned mercury, arsenic, lead, phosphorus, etc., the first of which is especially apt to be met with as a cause of anæmia in children. Certain of these substances probably produce anæmia in other ways than by a hæmolytic action, while others are directly destructive to the blood-cells. It is an important fact that a prolonged course of mercury carried out in the treatment of constitutional syphilis may itself be productive of profound anæmia. Chlorate of potassium is a well-recognized cause of destruction of the red blood-cells within the body, and other substances, among them

---

<sup>1</sup> Lehrbuch d. Kinderkrankheiten, 1881, 151.

the antipyretics, and especially pyrocin,<sup>1</sup> have been shown to have a deleterious action on the blood.

PARASITIC ANÆMIA likewise includes a variety of forms, some of them hæmolytic, others not.

(a) Chief among them is the anæmia accompanying malaria, which would appear to be due to the immediate hæmolytic action of the *Plasmodium malariae* upon the red blood-cells, though our knowledge is not yet sufficiently extended to entertain a positive conviction of this. Malarial anæmia may, on the other hand, be classified as an anæmia of malnutrition, due to the constitutional effect of the disease. Or it may be that the greatly-enlarged spleen often seen in chronic malaria is not without etiological influence; though these cases are more properly relegated to "splenic anæmia." The anæmia of syphilis possibly belongs to the group of anæmias due to the hæmolytic action of a microbial parasite.

(b) Certain intestinal worms have been found to be the cause of, or at least to be associated with, an anæmia so profound that the patients exhibited all the symptoms of pernicious anæmia, and were, in fact, considered to be examples of this disease. An instance in which the *Bothriocephalus latus* appeared to produce the characteristic symptoms in a child of thirteen years is reported by Schapiro,<sup>2</sup> and other examples are published by Reyher<sup>3</sup> and Runeberg.<sup>4</sup> It is possible that the anæmia here is of a hæmolytic type, being the result of the absorption into the blood of poisonous chemical matters produced by the worm under certain conditions.

It does not, however, seem definitely established that there exists any etiological connection between the bothriocephalus and the anæmia, since the parasite is frequently present in large numbers without producing the slightest evidence of a disorder of the blood.

The *Anchylostomum duodenale*, or *Dochmius duodenalis*, is the cause of the disorder variously denominated Egyptian or African chlorosis, brick-burner's anæmia, Gotthard-tunnel disease, tropical anæmia, etc. This profound anæmia occurs in both young and old subjects, closely resembles pernicious anæmia in its symptoms, and is attributable to the direct loss of blood produced by the suction of the worms. This form of parasitic anæmia, therefore, belongs rather to the post-hæmorrhagic type.

A small thread-worm, *Anguillula intestinalis*, and its Rhabditiform embryos have been found in the intestine in vast numbers, producing the "Cochin-China diarrhœa," and the marasmatic and anæmic condition depending on this.

(c) The *Bilharzia hæmatobia* and the *Filaria sanguinis hominis* are other worms not situated in the intestinal tract, which may produce anæmia; the latter probably by obstructing the circulation in the lymphatic vessels or by

<sup>1</sup> Renvers, Berlin. Klin. Wochenschr., 1889, 986.

<sup>2</sup> Zeitschrift f. Klin. Med., xiii. 416.

<sup>3</sup> Deutsches Archiv f. Klin. Med., xxxix. 31.

<sup>4</sup> Ibid., xli. 304.

the actual loss of chyle; the former only in severe cases, and probably by the direct loss of blood in the urine. Both of these parasites occur in children as well as in adults. (See Parasites in the Blood.)

POST-HEMORRHAGIC ANÆMIA is the first well-defined variety of the second class of cases, apart from certain of the parasitic forms just referred to. It is less frequently seen in childhood than in adult life. Among its causes in children<sup>1</sup> are mæna, hæmophilia, purpura, umbilical hemorrhage, internal hemorrhages occurring soon after birth, epistaxis, cephalohæmatomata, traumata, etc.

ANÆMIA FROM ABSTRACTION OF ALBUMEN from the blood is another form allied in some respects to the preceding. It is well seen in all diseases where this loss has occurred through long-continued suppuration, as in Pott's disease, hip-joint disease, advanced pulmonary tuberculosis, and chronic suppurative processes of other forms. It may also be observed in chronic Bright's disease with persistent loss of albumen in the urine, in cirrhosis of the liver and in heart-disease with effusion of fluid into the serous cavities, in dysentery with profuse highly-albuminous passages, in excessive onanism, in rapidly-growing neoplasms, etc.

ANÆMIA OF MALNUTRITION, or inanition-anæmia, includes by far the largest and most varied number of cases under the non-cytogenic, oligocythæmic forms.

(a) Here may be mentioned first of all that seen in simple inanition, the result of insufficient nourishment of a proper sort,—an anæmia of starvation. Many of the so common instances of anæmia and emaciation seen in young children belong to this category.

(b) A similar condition results from the imperfect absorption of nourishment, the result of organic or functional diseases of the digestive tract. Among these are probably to be classified those cases described as pernicious anæmia in which a well-marked atrophy of the gastric mucous membrane has been found. Instances of this have been reported by various observers. A feature of anæmia from this cause, too, is that there is frequently an absence of emaciation, as in pernicious anæmia. This absence is, however, by no means seen in all cases. It is very probable that the atrophy may be secondary to the blood-changes in some instances.

Another form of anæmia to be included here is that which develops in severe and long-continued diarrhœa. This is due not so much to the removal of albumen from the blood as to a lack of absorption of the undigested food and the peptones, which are hurried through and out of the intestine by the increased peristalsis.

(c) Improper hygienic surroundings, of whatever sort, are common causes of anæmia. A proper amount of oxygen is equally essential with proper food for the perfect condition of the blood, and the anæmias resulting so frequently in children from too close confinement to poorly-ventilated rooms

---

<sup>1</sup> Jacobi, Archives of Medicine, February, 1881.



is consequently to be classified here. The pallor so prevalent among the inmates of many homes for children is a good example of the influence of this factor.

(d) Perhaps best classified among the anæmias of malnutrition is that seen in congenital syphilis, tuberculosis, rachitis, serofula, rheumatism, possibly malaria, scurvy, and other constitutional diseases. The pallor may even make its appearance before any of the local manifestations of the general disorder become manifest. In various, and usually unknown, ways the general nutrition of patients with these diseases becomes profoundly altered, and the blood necessarily suffers also. The exact etiological relation of the constitutional affections to the anæmia cannot be positively determined in the present state of our knowledge. It is possible that the diseases influence directly the functions of the blood-making organs, relegating these anæmias rather to the cytogenic type; or that rickets and the extreme anæmia which is often its first symptom are both the effect of a common cause.

**Symptoms.**—The condition of the blood after a hemorrhage of considerable amount is that of simple oligæmia, which, however, almost immediately changes by the absorption of water into an oligocythæmia, combined with leucocytosis and hypalbuminosis. The fibrin net-work, too, is less marked than in health.<sup>1</sup> In the other forms of non-cytogenic anæmia described its state is very similar, but the amount of fibrin is often increased, and the number of leucocytes but slightly so.<sup>1</sup> The size and shape of the red blood-cells are generally not much altered, except in extreme post-hemorrhagic anæmia, in which poikilocytosis is sometimes quite marked. The diminution in the number of red blood-cells is often very great, though probably never so extreme as is sometimes seen in pernicious anæmia.

The other symptoms of the anæmias which have been discussed must necessarily vary to some extent in different cases, depending on the nature of the cause. In general may be mentioned pallor of the skin and mucous membranes, eventually more or less emaciation, smallness and flabbiness of the muscles if the disease has lasted for any length of time, clubbing of the fingers, irritability of the nervous system, impairment or perversion of appetite, irregularity of the bowels, and imperfect digestion. Indisposition to exercise is often, but not always, seen in anæmia in children. Jacobi<sup>2</sup> calls attention to the fact that babies who cry most of the night are often suffering from anæmia, and that the crying may frequently be prevented by food or stimulant given before they are put to bed. The urine is generally light-colored and of low specific gravity, and there is often incontinence of it even when the child is advanced in years. Some degree of œdema may appear, especially in the feet and ankles. Epistaxis is very frequent. Leucorrhœa attends anæmia in not a few cases in girls even of only two or three years of age. The pulse is small; the heart's action is accelerated; palpitation is

---

<sup>1</sup> Osler, *System of Medicine by American Authors*, 1885, iii. 888.

<sup>2</sup> *Archives of Medicine*, 1881, p. 16.

frequent. A venous hum can occasionally be heard in the jugulars in children of but two or three years of age, but Bednar<sup>1</sup> never detected it in the newly-born. Anæmic murmurs may often be heard over the præcordium, and not infrequently over the fontanel and in the carotids. Breathlessness and palpitation are sometimes present, but are not common in children.<sup>2</sup> Catarrh of the respiratory passages is liable to develop. In young children anæmia of the brain, perhaps consecutive to a profuse diarrhœa, produces general coldness, semi-stupor, and finally death.

**Pathology and Pathological Anatomy.**—The bodies of those who have died in a very anæmic condition exhibit a more than ordinary pallor, while the post-mortem rigor and the cadaveric lividity are generally but little marked. The adipose tissue everywhere is usually much diminished, and œdema and serous effusions may be present. The internal organs are pale, and often decidedly smaller than normal. One of the most characteristic changes in advanced anæmia is the tendency to wide-spread fatty degeneration of the organs, best seen in the heart-muscle and the lining of the large blood-vessels.

It is a noteworthy fact that, contrary to the statement frequently made, the bone-marrow in severe cases of the symptomatic anæmias may exhibit the lymphoid appearance often described as characteristic of pernicious anæmia. Instances of this have been reported by Neumann<sup>3</sup> and others, and the condition has been experimentally produced in dogs by repeatedly bleeding them.

Immermann<sup>4</sup> attributes the atrophy and fatty degeneration to a condition of hypalbuminosis rather than to oligocythæmia, since it is the amount of albumen supplied them upon which the nourishment of the cells of the organs depends. The oligocythæmia is, indeed, a conservative feature, since, on account of it, less oxygen is supplied to the tissues, and the rapidity of their consumption is thereby diminished.

**Diagnosis and Prognosis.**—The diagnosis of secondary anæmia is the recognition of its cause; and this is a matter of the greatest importance, on which the formation of the prognosis depends.

**Treatment.**—The treatment consists primarily in that directed against the source of the pathological alteration of the blood. In addition to this, and when not contra-indicated, attention must be directed to the treatment of the anæmia itself. For this purpose iron will be found to be the drug on which the greatest reliance can be placed. Owing to the irritability of the stomach which often exists, it should be given in some unirritating form, as the malate, lactate, citrate, or albuminate.

The administration of a proper amount and sort of nourishment is also all-important, while sufficient fresh air and exercise and the establishment

<sup>1</sup> Die Krankheiten der Neugeborenen und Säuglinge, 1853.

<sup>2</sup> Eustace Smith, Diseases in Children, 1884, p. 242.

<sup>3</sup> Zeitschr. f. Klin. Med., 1881, iii. 414.

<sup>4</sup> Ziemssen's Handb. d. Spec. Path. u. Ther., 1875, xiii. 374.

of proper hygienic surroundings are indispensable. Arsenic is a useful remedy, especially in chronic and obstinate cases, and may be given in proportionately much larger doses than adults will bear. Great reliance, too, can be placed on cod-liver oil, either alone or in combination with iron. Strychnine proves useful in some instances, as does phosphorus in others.

---

## CHLOROSIS.

**Synonymes.**—Chloranæmia, Chloroanæmia, Morbus virgineus, Green-sickness, etc.

**Definition.**—This form of anæmia, which has been known since the time of Hippocrates, may be classified either as an oligochromæmia of non-cytogenic origin, or, as seems to me more probably correct, as a cytogenic anæmia of peculiar type. It is a variety of anæmia occurring almost exclusively in girls and young women, and characterized by a peculiar greenish-yellow and exceedingly anæmic hue, but without emaciation, by a well-defined oligochromæmia without a proportionate oligocythæmia, by extreme languor, dyspnœa, and palpitation on exertion, and often by cardiacalgic attacks.

**Etiology.**—The cause of the disease has been a subject of great dispute. The influence of heredity as a predisposing factor is seen in many cases; the female members of the same family for several generations often becoming chlorotic at the same period of life. There may exist, further, a predisposition resulting from a congenital imperfect development of certain organs. Particularly have claims been made for the influence of an undeveloped state of the uterus and ovaries, but such a defect is by no means constantly present. Virchow<sup>1</sup> in 1872 advanced the theory that chlorosis was due to a congenital smallness of the heart and narrowness of the vessels, as a result of which an insufficient supply of blood was furnished to the digestive and hæmatopoietic organs at the time when the rapidly-advancing growth of puberty demanded the most perfect nutrition. According to this view, the disease is present from infancy, though latent. This explanation has been accepted as conclusive by Baginsky<sup>2</sup> and favorably regarded by many others.

But, though it may apply to many cases, it does not, I think, account for the numerous instances of rapidly-developing chlorosis, nor for the speedy cure usually, and often permanently, produced by the institution of appropriate treatment. Fagge<sup>3</sup> believes that the narrowness is not congenital, but the result of an endocarditis occurring in childhood. Moreover, this peculiar condition is seen in males as well as in females, and has

---

<sup>1</sup> Ueber die Chlorose und Anomalien in Gefässapparate, 1872.

<sup>2</sup> Lehrb. d. Kinderkrankh., 1887, 290.

<sup>3</sup> Practice of Medicine, 1886, ii. 608.

its own characteristic symptoms, not at all characteristic of chlorosis. This has been shown in the cases reported by Fräntzel.<sup>1</sup>

Sex has a strongly predisposing influence, females being those almost exclusively attacked. The disease does, however, appear occasionally in boys, according to the statements of Lund,<sup>2</sup> Nonat,<sup>3</sup> Hayem,<sup>4</sup> and others. The last-mentioned writer has seen it in all the boys in one family.

Age is also an etiological factor. Most cases develop between the ages of twenty-four and fourteen years, though the disease may appear at a period of life much younger than this, as Cantrell,<sup>5</sup> Förster,<sup>6</sup> Becquerel,<sup>7</sup> and others have shown.

Previously existing poor health or the occurrence of some severe malady, also bad hygienic conditions, insufficient food, and unsuitable occupation, are not without etiological significance. The affection appears to be quite common among factory-girls, but by no means spares girls of the upper circles of society. Influences acting upon the nervous system are of great importance: among these may be mentioned psychic disturbances of various sorts, masturbation, excessive mental or bodily labor, etc.

Finally, the establishment of the menstrual function has been largely accredited with the production of chlorosis, though it can certainly not be considered the only factor; and it is difficult sometimes to determine to how great a degree a menstrual irregularity is the cause of the blood-affection, or how far it is the concomitant or the effect of this. This is also the view which Strümpell<sup>8</sup> expresses. I have repeatedly observed cases in which the other symptoms of chlorosis appeared before the diminution in the amount of the menstrual discharge, which had previously always been normal in every particular. Stephenson concludes,<sup>9</sup> from the analysis of 232 cases, that scanty and irregular menstruation is as constantly present in chlorosis as is the imperfect formation of the red blood-cells; but he considers the conditions independent of each other,—not related as cause and effect.

**Symptoms.**—The symptoms of chlorosis usually develop insidiously, and consist of a more or less well marked yellowish-green, anæmic hue, though the cheeks are sometimes flushed (*chlorosis rubra*); no diminution in the amount of fat, and sometimes even an increase of it; occasionally slight œdema; dyspnoea, palpitation, and a sense of fatigue on the slightest exertion; languor; a tendency to dizziness and fainting; disturbance of digestion, with diminished or depraved appetite, and constipation. Irritability of the nervous system is present, and hysterical convulsive seizures

<sup>1</sup> Deutsche Med. Wochenschr., 1888, 589.

<sup>2</sup> Hayem, Du Sang, 1889, p. 744.

<sup>3</sup> Traité théor. et prat. de la Chlorose, 1864.

<sup>4</sup> Du Sang, 1889, p. 745.

<sup>5</sup> Immermann, in Ziemssen's Handbuch, 1875, xiii, 533.

<sup>6</sup> Gerhardt's Handb. der Kinderkrankh., 1877, iii., 1st Half, 206.

<sup>7</sup> Traité clin. des Maladies de l'Utérus, etc., 1859.

<sup>8</sup> Spec. Path. u. Therap., 1886, ii. 1, 178.

<sup>9</sup> Ann. Univ. Med. Sci., 1890, ii. E.; from Brit. Med. Jour., January 12, 1889.

are not infrequent in children.<sup>1</sup> Disorders of menstruation are very commonly present. The heart's impulse may be widened, with evidences of dilatation of the right ventricle. Systolic murmurs may sometimes be heard over the præcordium and in the carotids, and there is usually a well-marked venous hum in the jugular or other veins, which may even be perceived by the patient as a continuous humming sound in the head. The pulse is small and the arterial tension low. The urine is of low specific gravity and light color, and contains a diminished amount of urea and uric acid, and sometimes a trace of albumen, but casts are never found in it.<sup>2</sup> A peculiar pigmentation of the dorsal surfaces of the fingers has been described.<sup>3</sup>

Attacks of gastralgia are usually considered characteristic of chlorosis as distinguishing it from other forms of anæmia, and are probably of a purely neurotic nature and dependent on the alteration of the blood. Förster<sup>4</sup> lays particular stress on the importance of this symptom; and, having shown that in the statistics of a large number of anæmic children it was much more common after the age of six years in girls than in boys, he concludes that this is an indication that the anæmia was really a chlorosis in the case of the former. Other neuralgias, particularly of the trigeminal, are present with greater frequency in older than in younger children.

Fever is certainly of the rarest occurrence in chlorosis, though it has been reported by a few writers.<sup>5</sup> I cannot but believe that it is doubtful whether it ever occurs as an actual symptom of uncomplicated chlorosis. Hayem<sup>6</sup> reports its presence in only two out of seven cases of the disease, in which records of the temperature were taken; and in both of these there was also extreme diminution in the number of red blood-cells,—*i.e.*, an oligocythæmia, if at all a chlorosis.

The state of the blood is of the greatest interest. The most striking characteristic is a marked diminution in the percentage of hæmoglobin. This oligochromæmia, first pointed out by Duncan,<sup>7</sup> is out of all proportion to the reduction in the number of red blood-cells. Oligocythæmia cannot, in fact, be regarded as at all a characteristic of pure chlorosis, and when present—as it, indeed, frequently is—it must be considered a complication. The majority of recent investigations establish that this is one of the most marked features of the disease, and that the disproportion between the reduction of the hæmoglobin and that of the red blood-cells must be present in

<sup>1</sup> Förster, Gerhardt's Handbuch, etc., 1877, iii. 211.

<sup>2</sup> Eichhorst, Spec. Path. u. Therap., 1885, iv. 26.

<sup>3</sup> Bouchard, Pouzet, Ann. Univ. Med. Sci., 1889, iv. J.

<sup>4</sup> Gerhardt's Handb. d. Kinderkr., 1877, iii. 1, 210.

<sup>5</sup> Jaccoud, La Semaine Méd., August 8, 1888; Trazit, Jour. de Méd. et de Chir., November, 1888; Wunderlich, Handb. d. Path. u. d. Therap., 1856, iv.; Schulze, Ueber Chlorose, Berlin, 1868; Mollière, Lyon Méd., December 10, 1882, and February 8, 1885; Leclerc, Thèse de Lyon, 1885.

<sup>6</sup> Du Sang, 1889, p. 673.

<sup>7</sup> Sitzungsbericht d. Kais. Akad. d. Wissenschaften zu Wien, 1867.

order to allow of the diagnosis of chlorosis in any case. Gräber<sup>1</sup> found that the number of red blood-cells was not diminished in twenty-eight cases of pure chlorosis, the average being 4,482,000 per cubic millimetre. In all of them, however, the average amount of hæmoglobin was but one-half or one-third of the normal amount. Henry is probably right<sup>2</sup> in refusing to recognize as chlorosis the cases in which Laache<sup>3</sup> found all the clinical symptoms of anæmia but without the blood-changes. Of 13 cases which I have quite recently examined, the results were as follows, the percentages of red cells being based on a normal of 5,000,000 :

	I.	II.	III.	IV.	V.	VI.	VII.	VIII.	IX.	X.	XI.	XII.	XIII.
Percentage of red blood-cells .	69	66.5	81	57.5	80	94	83	55.5	86.4	80	97.6	76.5	80
Percentage of hæmoglobin . .	36	37	35	32	58	51	31	31	39	35	41	29	58

It will be seen that in two cases only was there a decided reduction in the number of corpuscles, while in all the amount of hæmoglobin was much below normal. In the 10th case, which was a typical example of *chlorosis rubra*, the corpuscles had increased to 5,248,000, or 105 per cent., after a month's treatment, but the hæmoglobin had reached only 57 per cent.

The red blood-cells vary greatly in size and form, and numerous microcytes and some macrocytes are often to be seen. Several observers have found the average diameter of the red blood-corpuscles somewhat diminished.<sup>4</sup> The normal relations of the white blood-cells are not essentially affected.

Immermann<sup>5</sup> says that the amount of the plasma and the contained albumen is not diminished in chlorosis, and that this is a distinguishing characteristic of the disease as compared with anæmia ; while Becquerel and Rodier<sup>6</sup> assert that the amount of albumen is even sometimes increased.

**Pathological Anatomy.**—No characteristic changes are to be found post mortem. The adipose tissue is usually well preserved. A rudimentary state of the uterus and ovaries has been noticed in some cases, and a narrowness of the arterial system with smallness of the heart and excessive thinness of the vessel-walls in others. No change has been detected in the blood-making organs which could explain the cause or the nature of the disease.

**Pathology.**—We are still greatly at sea regarding the pathology of chlorosis. If, as Zander<sup>7</sup> and Bunge<sup>8</sup> claim, the condition of the blood is due to a defective absorption of iron from the intestine, the nature of the affection would be clear, and we would class it as a non-cytogenic anæmia. Bunge's theory is, that a large excess of the products of decomposition in the

<sup>1</sup> Deutsche Med. Wochenschr., 1887.

<sup>2</sup> Anæmia, 1887, p. 92.

<sup>3</sup> Die Anämie, Christiania, 1883.

<sup>4</sup> Hayem, Du Sang, 1889, 621 ; Laache, Die Anämie, 1883 ; Willcocks, Practitioner, 1883 ; Gräber, Deutsche Med. Wochenschr., 1887.

<sup>5</sup> Ziemssen's Handb. d. Spec. Path., 1875, xiii. 560.

<sup>6</sup> Gaz. de Paris, 1844, Nos. 47-51.

<sup>7</sup> Virchow's Arch., lxxxiv.

<sup>8</sup> Practitioner, August, 1881.

intestine, and especially of sulphur, breaks up the assimilable iron and unites with it, thus preventing its absorption. Large doses of the drug are consequently required in order that these substances may be neutralized, after which absorption of iron can begin. Zander is of the opinion that there is a deficiency in the hydrochloric acid of the gastric secretion, as a result of which the iron ingested in the food is not dissolved and rendered assimilable.

These explanations are not satisfactory, for they by no means apply to all cases, notably those in which large amounts of iron are administered without effect, those which recover without treatment or under minute doses of iron, and those which are cured by other plans of treatment than iron or hydrochloric acid, or which prove intractable to all. As there is nothing in the other possible causes mentioned adequately to account for the origin of the disease, we are forced to consider chlorosis a cytogenic anæmia of peculiar form, due to an inability on the part of the blood-making apparatus to produce a proper quality of the blood,—*i.e.*, a primary, defective hæmogenesis. This inability is undoubtedly occasioned to some extent by predisposing causes, but must also in many cases depend largely on some sort of functional lack of energy of the blood-making organs themselves. The classification of chlorosis as a "primary" anæmia is adopted by Fagge,<sup>1</sup> Strümpell,<sup>2</sup> and others.

Various other views regarding the pathogenesis of the disease have been expressed. Gräber<sup>3</sup> believes it to be due to an excessive alkalinity of the blood, and Clark<sup>4</sup> and Duclos<sup>5</sup> are of the opinion that it is a toxæmia resulting from the retention and absorption of decomposing fecal matter. Henry<sup>6</sup> considers it to be the expression of a general cachexia rather than an affection of the blood merely. He is disposed, too,<sup>7</sup> to deny to chlorosis the characteristic blood-change described; and says that the condition of the blood depends in each case upon the stage of the disease. He agrees in this respect with Hayem,<sup>8</sup> who recognizes three forms or stages of the affection, determined respectively by the number of red blood-corpuscles present. I have already expressed my inclination towards the view that the oligocythæmia, when present, should be regarded as a complicating element, and not as a symptom of chlorosis.

**Complications and Sequelæ.**—Gastric ulcer is one of the principal complications, though less frequent in children than in adults, and Baginsky<sup>9</sup> believes that it is not uncommonly the cause of the gastralgie attacks. Chorea is often seen in chlorotic children, and its development is perhaps favored by the disease of the blood.<sup>10</sup> Pulmonary tuberculosis appears

<sup>1</sup> Practice of Medicine, 1886, ii. 606.

<sup>2</sup> Spec. Path. u. Therap., 1886, ii. 177.

<sup>3</sup> Therap. Monatshefte, 1887.

<sup>4</sup> Lancet, 1887.

<sup>5</sup> Revue Générale, 1887.

<sup>6</sup> Ann. Univ. Med. Sci., 1890, ii. E.

<sup>7</sup> Ibid., 1889, iv. J.

<sup>8</sup> Du Sang, 669.

<sup>9</sup> Lehrb. d. Kinderkrank., 1887, 291.

<sup>10</sup> Förster, Gerhard's Handbuch, etc., 1877, iii. 211.

especially liable to develop in chlorotic patients. Without doubt chlorosis can be complicated by anæmia, and even by pernicious anæmia; and in this way are to be explained the different grades of the disease as given by Hayem and Usac.<sup>1</sup> Virchow says that there exists a strong predisposition to endocarditis in chlorotic patients. Basedow's disease has been stated by Friedreich<sup>2</sup> to be prone to develop in chlorotic girls and women. Vergely<sup>3</sup> has been able to collect a few cases of thrombosis of the veins or arteries, and Huels<sup>4</sup> reports another instance of very widely spread thrombosis.

**Diagnosis.**—The diagnosis rests mainly on the characteristic condition of the blood, the occurrence of the disease chiefly in girls at puberty, the persistence of the adipose tissue, and the association with disordered menstruation.

From secondary anæmia chlorosis is to be distinguished by the absence of a definite, discernible cause, and usually of decided emaciation, and by the presence of the characteristic hæmic alteration and the hue of the skin.

From pernicious anæmia it differs in that the relation of the percentage of hæmoglobin to that of the red blood-cells is exactly reversed in the two diseases. There is, further, neither retinal hemorrhage nor fever: in fact, the occurrence of fever in a case reported as chlorosis would render the correctness of the diagnosis extremely doubtful, or would indicate that some complication had arisen.

The œdema and albuminuria sometimes met with in chlorosis are distinguished from those of Bright's disease by the absence of casts.

**Prognosis.**—Fatal cases the result of chlorosis itself are almost never witnessed. Death is due to some intercurrent disease. Though the duration of the malady is very variable and often much prolonged, most cases yield to appropriate treatment. Relapses are liable to occur in many instances; probably in those in which the vascular anomaly described by Virchow exists. There are certain cases, too, which prove most intractable.

**Treatment.**—Prophylaxis is of the greatest importance, and must be practised from early childhood. A proper amount of exercise, cold bathing, fresh air, and sunlight, and proper nourishment, especially of an animal nature, must be insisted upon, as well as the avoidance of the summer heat, nervous excitement, and of over-exertion either of the body or mind, and especially of close confinement and overwork in factories or schools. All suitable measures must be employed to remove indications of debility, and to preserve perfect health. The child must, in fact, be made ready to meet the demands of puberty. To combat the disease when present, iron is almost a specific, but must be given persistently. Full doses are recommended by most writers. Bland's pill is a favorite form in which to ad-

<sup>1</sup> De la Chlorose chez l'Homme, 1853.

<sup>2</sup> Immermann, Ziemssen's Handbuch, 1875, xiii. 590.

<sup>3</sup> Ann. Univ. Med. Sci., 1890, ii. E.; from Jour. de Méd. de Bordeaux, August 18, 1889.

<sup>4</sup> Ibid.; from Berlin. Klin. Wochenschr., October 14, 1889.



minister it. This consists of half an ounce each of carbonate of potassium and of sulphate of iron, divided into ninety-six pills. Three of these may be taken three times a day. Other preparations of iron may be selected, and when there is any digestive disturbance, and particularly where the existence of gastric ulcer is suspected, some entirely unirritating form of it must be employed. Other tonics, such as cod-liver oil or strychnine, will also be found useful as adjuvants. The digestion will frequently need to be carefully regulated, and may require the administration of dilute hydrochloric acid. Hygienic conditions must be carefully looked after, and massage, cold sponging, and sea-bathing are of value. In cases in which there is no catarrhal or inflammatory condition of the digestive tract, and in which iron has proved useless, Schultz and Strübing<sup>1</sup> have obtained good results from the administration of sulphur. Sée<sup>2</sup> gives an almost exclusively albuminous diet, and rarely administers iron. Inhalations of oxygen have also been advised.<sup>3</sup> Antiq<sup>4</sup> obtained the best results with enemata of defibrinated blood.

---

## LEUKÆMIA.

**Synonyme.**—Leucocythæmia (Bennett).

**Definition.**—A disease of hæmatopoiesis, characterized by a great and progressive increase in the number of white blood-cells, and a diminution in the number of red blood-cells, with hyperplasia of the spleen and bone-marrow, and often of the lymphatic tissue in other parts of the body.

**History.**—The peculiar appearance of the blood in leukæmia was observed and described by Craigie and Bennett in 1845,<sup>5</sup> and, indeed, by Velpeau, Piorry, Bichat, Morgagni, Rokitansky, Andral, Donné, and others previously. Virchow,<sup>6</sup> writing a month after Bennett, recognized that the condition was really an increase in the number of white blood-cells, and not due to the admixture of pus with blood, as Bennett had supposed. There seems to be no doubt that he, too, was the first to appreciate the probable connection between this increase and the change in the spleen and lymphatic glands. Fuller and Walshe in 1846<sup>7</sup> demonstrated the change in the blood of living patients, and Vogel<sup>8</sup> in 1849 diagnosed a case

<sup>1</sup> Deutsche Med. Wochenschrift, 1887, No. 2.

<sup>2</sup> L'Union Méd., 1888, No. 97.

<sup>3</sup> Jaccoud, La Semaine Méd., 1888.

<sup>4</sup> Ann. Univ. Med. Sci., 1890, ii. E, from Lyon Méd., October 20, 1889.

<sup>5</sup> Edinburgh Medical Journal, October, 1845.

<sup>6</sup> Various contributions in Froriep's Notizen, 1845, Med. Zeit. des Vereins f. Heilkunde, 1846, August and September, and 1847, January; Virchow's Archiv, 1847, i.; *ibid.*, v.; *Gesammte Abhandlungen*, 190; *Geschwülste*, ii. 565.

<sup>7</sup> Fagge, *Practice of Medicine*, 1886, ii. 343.

<sup>8</sup> Virchow's Archiv, iii.

during life. Virchow, again, in 1853 divided the disease into a splenic and a lymphatic variety; and later, in 1870, Neumann<sup>1</sup> described a myelogenous form. These three forms are still recognized; and unquestionable instances of pure forms have been reported, though they are rarely found unmixed. The spleen and probably the marrow also are nearly always involved. The lymphatic glands are in most cases but slightly, if at all, affected. Among the earliest reports of the occurrence of cases in children are those of Löschner,<sup>2</sup> Blumenthal,<sup>3</sup> Golitzinsky,<sup>4</sup> and Biermer,<sup>5</sup> and cases have since been reported by various observers.

**Etiology.**—Of the causes of the disease little is known. Heredity, or rather the existence of a family predisposition, has been noticed in a few cases. Casati<sup>6</sup> relates an instance of the disease in a girl ten years of age, whose father and grandmother were said to have suffered from it likewise; Biermer<sup>7</sup> reports the existence of it in two sisters of three and four and a half years respectively, in whose parents no predisposing cause could be detected; Senator<sup>8</sup> saw it in twins of one and a half years, and Eichhorst<sup>8</sup> observed a child of twelve years, as well as her cousin, with the disease. In some instances the existence of syphilis or tuberculosis in the parents appears to have predisposed the children to leukemia.

Age is an important predisposing factor, since the disease develops in most instances in middle life. It may, however, occur at any period of life, even in infants a few weeks or months old (Hayem,<sup>9</sup> ten months; Fagge,<sup>5</sup> twenty months; Seitz,<sup>10</sup> one year; Mosler,<sup>11</sup> sixteen months; Golitzinsky,<sup>4</sup> two cases, eleven months, and one week; Jaksch,<sup>12</sup> fourteen months; Mayer,<sup>13</sup> sixteen months). Sanger<sup>14</sup> even reports a case of leukemia in a fetus still-born at term. According to Baginsky,<sup>15</sup> from 15 to 20 per cent. of the cases are seen in children up to ten years of age; and Gerhardt<sup>16</sup> believes that it is as frequent in childhood as at a later period of life. The predisposing influence of age upon the tendency to the development of any particular form of leukemia has not yet been definitely determined. I do

<sup>1</sup> Arch. der Heilkunde, xi.

<sup>2</sup> Jahrb. f. Kinderheilk., 1859, 3, H. i.

<sup>3</sup> Jahresber. u. d. Findelanst. in Moskau, 1858

<sup>4</sup> Jahrb. f. Kinderheilk., 1861, 90.

<sup>5</sup> Gerhardt, Lehrbuch f. Kinderkr., 1881, 276.

<sup>6</sup> Rivista Clinica, 2a ser., ii., 1872.

<sup>7</sup> Virchow's Archiv, xxv. 142.

<sup>8</sup> Eichhorst, Spec. Path. u. Therap., 1885, iv. 3; Munch. Med. Wochenschr., January 1890, 49.

<sup>9</sup> Du Sang, 1889, p. 864.

<sup>10</sup> Deutsche Klinik, 1866, Nos. 15, 16.

<sup>11</sup> Berl. Klin. Wochenschr., 1864, Nos. 12, 15.

<sup>12</sup> Wien. Klin. Wochenschr., May 30, 1889; in Ann. Univ. Med. Sci., 1890, ii. E.

<sup>13</sup> Centralbl. f. Klin. Med., 1890, No. 1.

<sup>14</sup> Archiv f. Gynakol., Bd. xxxiii. H. 2.

<sup>15</sup> Lehrb. d. Kinderkr., 1887, 292.

<sup>16</sup> Ibid., 1881, 276.

not know of an instance of the myelogenous variety occurring in a child, unless the case of the girl of seventeen years described by Immermann<sup>1</sup> be included here. Golitzinsky<sup>2</sup> states that the lymphatic form is oftenest seen in children of a few months, and the splenic form more frequently in those of a year or more. Further investigations are needed upon this subject.

Sex, also, appears to be a decidedly predisposing factor, since of 201 cases collected by Birch-Hirschfeld<sup>3</sup> 135 (67.5 per cent.) were in males. Social and hygienic relations may be not without influence, as the majority of the cases occur in the lower and middle classes of society. It is possible, too, that there is a certain tendency to a geographical distribution of the affection.<sup>4</sup>

Of more immediate possible causes, malaria has often been said to exert a powerful influence in the production of leukæmia, and probably does so; but the opinions regarding this matter are very conflicting. The preponderance of medical evidence is in favor of the belief that syphilis, scrofula, and rickets, previously existing in the child, may be etiologically related to leukæmia. The acute infectious diseases cannot be said to be factors of any importance. Leukæmia has in adults sometimes developed shortly after a trauma in the splenic region,<sup>5</sup> and a possible instance of this occurring in a child has been reported by Mosler.<sup>6</sup>

**Symptoms.**—The disease begins insidiously, and there is no definite order in the appearance of the symptoms. Often the first indication is a progressive failure of health and strength, frequently with more or less irregular fever, while an enlargement of the abdomen becomes perceptible. In some cases bleeding from the nose or the bowels, or diarrhoea and vomiting, may be very early symptoms. Occasionally, too, as in two cases seen by Howard,<sup>7</sup> severe and even fatal hæmatemesis may be among the earliest indications.

Early in the affection enlargement of the spleen may be detected, and is often very considerable and accompanied by dilatation of the superficial abdominal veins. Anæmia, too, usually begins to develop early; and examination of the blood reveals the characteristic change to a greater or less extent, but the spleen or the lymphatic glands may be swollen a long time before this appears. Peculiar and unusual initial symptoms have been reported in children,<sup>8</sup> such as hysterical conditions, pain in the joints, attacks of excitement with loud crying, or dermal hemorrhages suggesting a purpuric state. After the disease is well advanced and the leukæmic cachexia well estab-

<sup>1</sup> Ziemssen's Handb. d. Spec. Path. u. Therap., 1875, xiii. 651.

<sup>2</sup> Jahrb. f. Kinderheilk., 1861, p. 90.

<sup>3</sup> Gerhardt's Handb. d. Kinderkr., 1878, iii. I., 309.

<sup>4</sup> Eichhorst, Spec. Path. u. Therap., 1885, iv. 2.

<sup>5</sup> De Chapelle, De la Leukémie dans ses Rapports avec la Traumatisme, Paris, 1881

<sup>6</sup> Berlin. Klin. Wochenschr., 1864, 152.

<sup>7</sup> Osler, in System of Medicine by American Authors, 1885, iii. 910.

<sup>8</sup> Gerhardt, Lehrb. d. Kinderkr., 1881, 278.

lished, many of the symptoms are simply those of marked anæmia. The child becomes feeble and irritable and indisposed to exertion. The pallor is marked and perhaps slightly icteric, and may rarely be even as intense as in pernicious anæmia. On the other hand, it is not unusual to see a circumscribed flush on the cheeks, even late in the disease. The appetite is generally lost; and, though it be preserved during a long period, as it sometimes is, progressive emaciation is the rule. Pustular eruptions and furuncles may occur, and intense itching has been reported. More or less subcutaneous œdema and effusion into the serous cavities take place in severe cases.

Palpitation, headache, vertigo, ringing in the ears, and attacks of syncope are indications of the presence of anæmia, but dyspnœa is often greater than can be accounted for in this way.<sup>1</sup> Sleep may be poor, or there may be decided drowsiness and in some instances delirium or coma.

Symptoms of gastric dyspepsia are rarely absent; flatulence is annoying; diarrhœa is a frequent and often fatal symptom, and is particularly liable to occur in children in whom rachitis has preceded the development of leukæmia. There is usually an increased thirst, even when there is no fever. The liver is generally decidedly enlarged, but well-marked icterus is infrequent. There may be evidences of slight bronchitis, or in advanced stages a cough due to pulmonary œdema. Dyspnœa may be further increased by the pressure of enlarged bronchial glands or of the hypertrophied spleen. The heart is sometimes displaced by the pressure of the spleen; a systolic murmur over the apex may be heard. The pulse is rapid and compressible. The temperature in the advanced stages usually exhibits a well-marked elevation, being either intermittent, remittent, or in the worst cases continuously high; and severe chills and profuse sweats sometimes accompany the pyrexia. Deafness has been observed, and has been made the subject of a special study by Gradenigo.<sup>2</sup>

Leukæmic retinitis, first described by Liebreich, is a characteristic of many cases, and may produce decided disturbance of vision. The eye-ground is pale, and the veins are tortuous, broad, pale, and of indistinct contour. The arteries are narrow and pale. Scattered retinal hemorrhages are of common occurrence. They are of a bright color, and aggregations of leucocytes are often seen as pale foci in the centre of them.

The urine is usually but little affected, though it occasionally contains albumen and a few hyaline casts. The amount of uric acid is nearly always increased. Hypoxanthin, lactic, acetic, formic, and hippuric acids, and certain other substances, are present in some cases but absent in others, and do not appear to possess any significance. The amount of urea has also been reported increased.<sup>3</sup> Obstinate priapism is a feature not rarely

<sup>1</sup> Bamberger, Wien. Med. Zeitung, 1887.

<sup>2</sup> Arch. f. Ohrenheilkunde, 1886, xxiii. 242.

<sup>3</sup> Sticker, Zeitschr. f. Klin. Med., 1888, xiv. 80.

present, as seen, for example, in the case of a boy of fifteen years reported by Edes.<sup>1</sup>

One of the most constant symptoms of leukaemia is the development of the hemorrhagic diathesis, as indicated by the frequent occurrence of retinal hemorrhages already referred to, epistaxis, hæmatemesis, petechiæ or large subdermal hemorrhages, bleeding from the gums, hemorrhage from the bowels, and, rarely, hæmaturia and hæmoptysis. Cerebral hemorrhage may also take place, but less often in children than in adults.

The condition of the blood in leukaemia is a symptom of the greatest importance. When drawn from the finger it coagulates slowly, has a pale and watery appearance, and is sometimes described as of a reddish-brown or even of a chocolate color. The number of red blood-corpuscles is usually reduced, though not excessively, and their proportion of hæmoglobin somewhat diminished. The smallest number of red corpuscles reported equalled 470,000, and occurred in a patient of Sorensen's.<sup>2</sup> They show no great alteration in size and shape, though poikilocytes and microcytes are occasionally seen. Nucleated red blood-cells are sometimes observed in small numbers. Osler<sup>3</sup> describes the number of hæmatoblasts as very variable, and refers also to the readiness with which crystals of hæmoglobin form.

The density of the fibrin net-work is increased, as is also the amount of water, according to the usual view, while the specific gravity is diminished. Sticker,<sup>4</sup> noticing the general fulness and increased tension of the blood-vessels, concluded that in leukaemia a hydræmic plethora existed. On the other hand, the investigations of Bamberger<sup>5</sup> in a case under his care showed that the solids of the blood were increased in amount, and that on this account the plethora could not be hydræmic. The lessened specific gravity of the blood was due to the large number of leucocytes present, the specific gravity of these being relatively low. He, too, has frequently noticed the abnormal fulness of the vessels, but would prefer to designate it by the title "leukæmic plethora." The alkalinity of the blood is diminished.<sup>6</sup>

Lactic and formic acids, hypoxanthin, xanthin, acetic and uric acids, urea, and certain other substances, are found abnormally present or in increased amount in leukæmic blood. Long octahedral crystals, similar to those seen in the sputum of asthmatic patients, were found by Charcot in leukæmic blood. They occur some within and some without the leucocytes, and have been described by White<sup>7</sup> under the name of "lenkosin." Damon<sup>8</sup>

<sup>1</sup> Boston Medical and Surgical Journal, 1871.

<sup>2</sup> Virchow-Hirsch, Jahresbericht, 1874, ix. 2, 314.

<sup>3</sup> System of Medicine by American Authors, 1885, iii. 913.

<sup>4</sup> Zeitschr. f. Klin. Med., 1888, xiv. 80.

<sup>5</sup> Wien. Klin. Wochenschr., 1888.

<sup>6</sup> Jaksch, Klin. Diagnostik, 1887, 14.

<sup>7</sup> Boston Medical and Surgical Journal, 1859.

<sup>8</sup> Henry, Anæmia, 1887, 84.

has described other crystals which were found by him in the blood of a leukæmic boy, and which he named "leucocrystallin."

But by far the most striking of the characteristics of the blood in leukæmia is the increase in the number of the white cells. (Plate I., Fig. 4.) The ratio of these to the red cells increases as the disease progresses, and in advanced cases very commonly equals 1 : 10 or 1 : 5, or may even reach 1 : 3 or 1 : 2, and in a patient seen by Sticker<sup>1</sup> equalled 1 : 0.5. The degree of increase of the white blood-cells which constitutes leukæmia in contradistinction to leucocytosis is variously stated by authors. Gerhardt<sup>2</sup> asserts that the ratio must at least equal 1 : 12, Fleischer and Penzoldt<sup>3</sup> give a necessary ratio of 1 : 20, while Henry<sup>4</sup> places 1 : 50 as the limits of leucocytosis. Osler<sup>5</sup> says that in the same case of leukæmia the ratio may vary greatly at different times, one week being 1 : 8 or 1 : 10, and perhaps the next week equalling 1 : 60 or even 1 : 150. Of course such a ratio as the latter, if constant, would almost exclude the existence of leukæmia.

The leucocytes of leukæmic blood possess certain characteristics distinguishing them from normal blood-corpuscles. Presenting great variations in size, three varieties may be distinguished : 1st. Those about one-half the size of a red blood-corpuscle, with single nucleus surrounded by a thin ring of protoplasm. 2d. A form of the size and appearance of the usual white blood-cell, having two or three nuclei, and with finely granular protoplasm. 3d. A large variety, even twice the size of a red blood-cell, containing three or four nuclei and finely or coarsely granular protoplasm. The first form is, according to Virchow, particularly frequent in leukæmia of the lymphatic type, while the larger cells are most common when the affection of the spleen predominates. The cells of the third class sometimes contain fine fat-globules in their interior, and probably arise in the medulla, and are characteristic of the myelogenous form of the disease.<sup>6</sup> The leucocytes in leukæmia show only sluggish and imperfect amœboid movements, or none at all.<sup>7</sup>

A further characteristic of leukæmic blood, as claimed by Ehrlich,<sup>8</sup> is its color reaction with eosin. Ehrlich describes in normal blood five varieties of leucocytes, depending upon the reaction which their protoplasmic granules exhibit with different reagents. In leukæmia there is, he states, a very marked increase of that variety of leucocyte whose granules possess the property of becoming deeply stained with eosin (*Eosinophilen Zellen*) when treated according to a certain method. In leucocytosis, on the other hand, these cells are diminished in number. Jaksch<sup>9</sup> concludes, as the result of

<sup>1</sup> Zeitschr. f. Klin. Med., 1888, xiv. 80.

<sup>2</sup> Lehrbuch der Kinderkrankh., 1881, 278.

<sup>3</sup> Jaksch, Klin. Diagnostik, 1887, 15.

<sup>4</sup> Anæmia, 1887, p. 97.

<sup>5</sup> System of Medicine by American Authors, 1885, iii. 919.

<sup>6</sup> Mosler, Berlin. Klin. Wochenschr., 1876, No. 49, 704.

<sup>7</sup> Cafavy, Lancet, 1880, ii. 769; Laking, *ibid.*; Neumann, *ibid.*

<sup>8</sup> Zeitschr. f. Klin. Med., i. 553.

<sup>9</sup> Klin. Diagnostik, 2e Aufl., 25.

PLATE I

Fig. 1

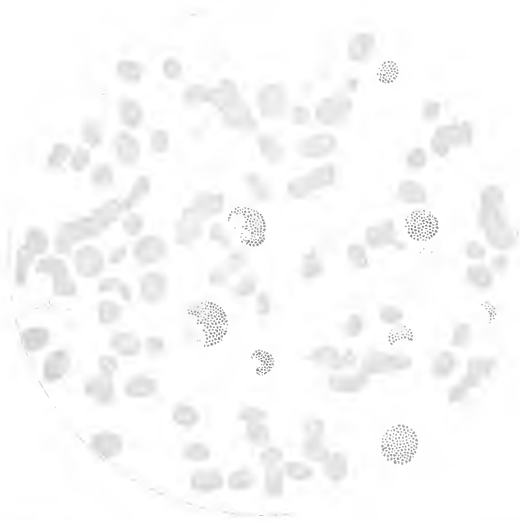
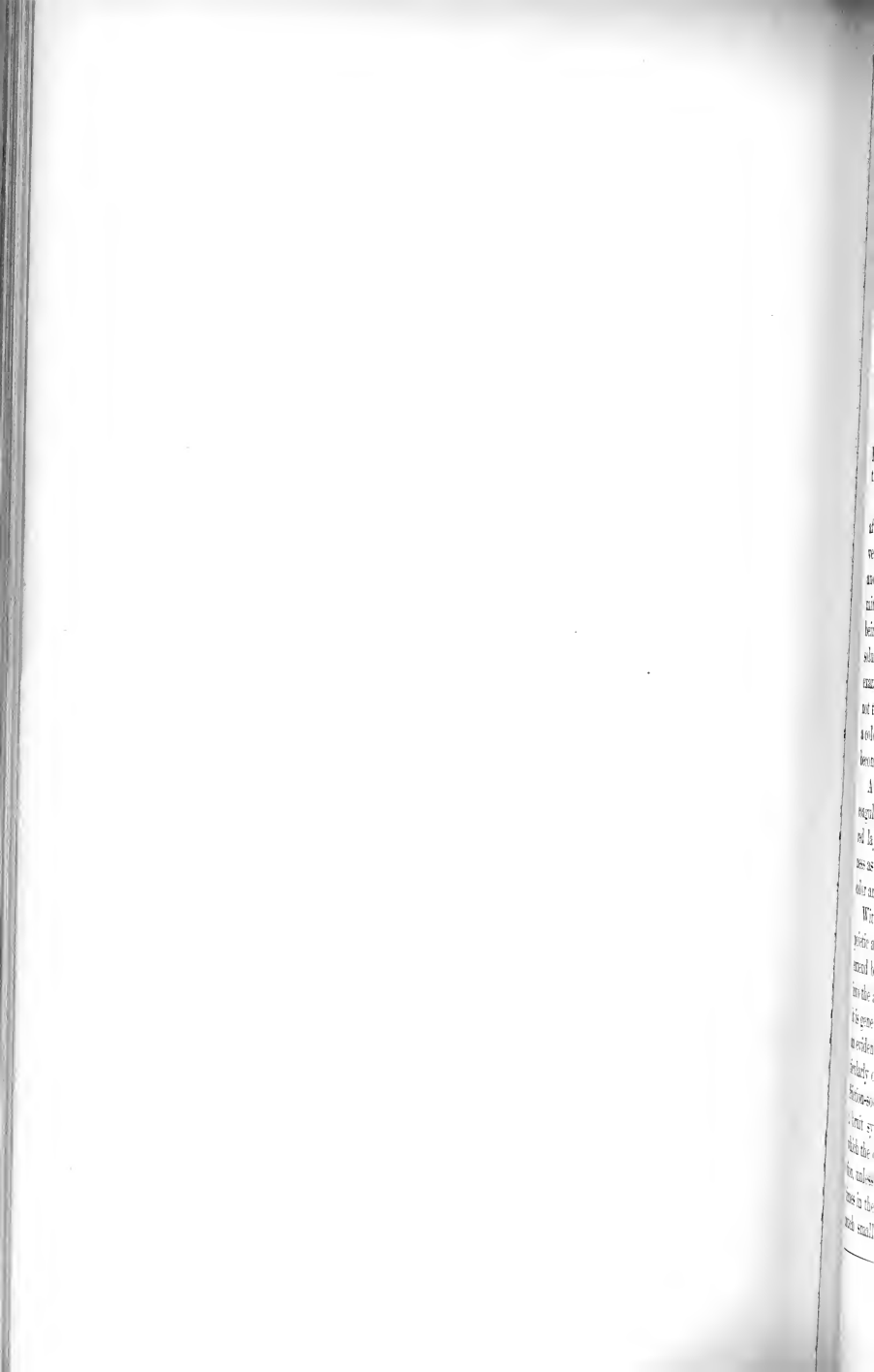

FIG. 1. Distribution of particles in a circular field of view.





his examination of blood in many diseases, that the presence of an increased number of these cells is generally characteristic of leukaemia, though it may very rarely be seen in other conditions.

The method consists in preparing a very thin layer of blood on a cover-glass and drying this at a temperature of about 120° C. for half a day or longer. It is then stained in a concentrated solution of eosin in glycerin, washed in water, dried in the air, and examined in oil of cloves. Huber<sup>1</sup> employs a triple stain consisting of a mixture of indulin, aurantia, and eosin, two grammes of each, in thirty grammes of glycerin. The preparation is stained with this for a half-hour or several days, and washed as before. The red blood-cells by this method should be colored a reddish yellow, and the leucocytes blue; while large leucocytes will also be found which are partly or completely filled with brilliantly stained bright-red granules,—the eosinophilous granules.

Huber's method has not proved at all satisfactory in my hands, and after much experimentation I have adopted the following procedure, with very satisfactory results. The cover-glass preparation of blood is prepared and dried in the way already described. It is then covered for fifteen minutes or longer with a concentrated solution of eosin in glycerin. After being washed in water it is immersed for a second or so in a dilute watery solution of methyl blue, at once again washed in water, dried in the air, and examined in turpentine balsam or xylol balsam. Care must be employed not to overstain with the blue. By this method the red blood-cells assume a color similar to that seen in fresh blood, or a little redder, the leucocytes become blue, and the eosin granules a brilliant red. Plate II., Fig. 8.

As a result of the great increase in the number of leucocytes, the blood coagulates outside of the body into three characteristic layers. The lower red layer, consisting of red blood-cells, is decidedly diminished in thickness as compared with that usually seen, while the middle one, of a milky color and consisting of leucocytes, is of unusual thickness.

With regard to the symptoms of leukaemia pertaining to the haematopoietic apparatus, the spleen is in most cases decidedly enlarged, and may extend beyond the median line downward even to the pelvis, and upward into the axilla. Its edge is hard and one or more notches can be felt, and it is generally somewhat painful on pressure. The enlargement produces an evident distention of the abdomen and lower portion of the thorax, particularly on the left side. A rough fremitus can often be detected, and a friction-sound heard over the organ, due to the presence of adhesions; while a bruit synchronous with the pulse is sometimes present. The position which the organ occupies varies in different cases. It moves with respiration, unless held in place by adhesions, and may vary in size at different times in the same case; being sometimes larger after a meal, and becoming much smaller after a profuse diarrhoea or hemorrhage. A diminution in

<sup>1</sup> Die Path. Hist. u. Bacteriol. Untersuchungsmeth., 1886, 49.

the size of the organ is not always followed by an improvement in the symptoms.<sup>1</sup>

The lymphatic glands are in most cases not much involved, though it is stated that the lymphatic form of leukaemia is commoner in children than in adults.<sup>2</sup> Some swelling of the glands, especially in the neck, may exist for years in lymphatic leukaemia before other symptoms of the disease make their appearance. Then, as in lymphatic anaemia, a more general glandular involvement either slowly or rapidly comes on, and the cachectic state develops. The enlarged glands are usually isolated, not tender on pressure, and not attached to the overlying skin. They vary in size, but most observers agree that it is exceptional to see them as large as in lymphatic anaemia. Leukaemic glands rarely suppurate.

The existence of medullary leukaemia can only be determined with any degree of certainty when swelling, softening, and tenderness of the bones are present, though changes in the marrow may exist without these symptoms. Even the tenderness is by no means an infallible test of medullary leukaemia. This is shown in the cases recently reported by Mayer,<sup>3</sup> in six of which the tenderness existed, though in only two cases was any actual lesion of the marrow found on post-mortem examination.

**Pathological Anatomy.**—The spleen, which naturally attracts the chief attention, is shown by post-mortem examination to be much enlarged, and may even fill the abdomen to a great extent. An adult spleen weighing eighteen and a half pounds has been reported by Brown.<sup>4</sup> In the early stages it is swollen and soft, the hyperplasia having been confined principally to the pulp, which is of a dark-red color, while the Malpighian bodies are grayish white and not much enlarged. It is at this period that rupture has been known to occur. A more advanced stage, however, is that in which the organ is usually seen. It is then hard, and the capsule much thickened and often adherent to neighboring peritoneal surfaces. It resists the knife, and on cutting it there is seen a great overgrowth of the fibrous tissue of the organ, the reticulum being very abundant and the cells scanty. The section does not look the same in every case. In many it is of a brown-red color and homogeneous appearance, much like that of liver, but sometimes fresh infarcts may be observed, or shining, yellowish or rust-colored patches indicate where previous hemorrhagic extravasations have been. The Malpighian bodies are, as a rule, indistinct or invisible, but more rarely they are hypertrophied and appear as yellowish nodules. The rarity of lymphoid new growths in the spleen is in sharp contrast with their frequency in this situation in lymphatic anaemia.

Enlargement of the lymphatic glands, when present, is probably nearly always secondary to the splenic affection, or at least accompanies it. The

<sup>1</sup> Henry, *Anaemia*, 1887, 87.

<sup>2</sup> Osler, *System of Medicine by American Authors*, 1885, iii. 915.

<sup>3</sup> *Centrabl. f. Klin. Med.*, 1890, No. 1.

<sup>4</sup> *Lancet*, 1877, ii.

glands seldom attain the dimensions seen in Hodgkin's disease, and there appears to be no invariable order in which they become involved, though the internal glands are rarely affected, and those in the neck are oftenest first attacked, especially in children. They may be of either the hard or the soft variety. In the latter they are usually isolated and movable under the skin; although the lymphatic tissue sometimes ruptures the capsule, uniting the individual glands into large masses, or even extending into the surrounding connective tissue. The soft gland exhibits on section a gray or grayish-red color, and contains numerous cells but scanty reticulum, while patches of hemorrhagic extravasation are sometimes seen. The hard gland is often a second stage of the soft variety, but may be hard from the outset. It exhibits an overgrowth of connective tissue, with a thickening of the capsule, and its section is of a gray color.

The changes in the bone-marrow may be of two sorts, forming the lymphoid and the pyoid marrow, which, however, are probably but different stages in the same process. In the pyoid variety, the one most frequently seen, the normal marrow of all the bones, or of the short and flat ones, is replaced by a yellowish-gray or yellowish-green substance, often much resembling thick pus. This was the condition in the first case studied by Neumann.<sup>1</sup> In the lymphoid variety the marrow becomes grayish red or even deep red in color, and somewhat of a jelly-like consistency. Foci of hemorrhagic extravasation may be discovered in the marrow in some instances.<sup>2</sup> The difference in the two forms seems to depend purely on the degree of increase in the number of the leucocytes, this being enormous in the pyoid form, while but few red blood-corpuscles are to be found. Three forms of cells may be recognized,—large granular ones with distinct nuclei; those resembling ordinary white blood-corpuscles; and small ones like lymph-cells, with large nuclei and a narrow ring of protoplasm. Nucleated red blood-cells are also very constantly found, and Charcot's crystals are very abundant. Cells containing red blood-corpuscles are not so common as in normal red marrow.<sup>3</sup> The bone-substance itself may be either normal, or expanded and spongy.

Of other organs containing lymphatic tissue the thymus gland may rarely exhibit great hypertrophy, as in the case of a boy five years of age reported by Cnyrim.<sup>4</sup> The tonsils may be early much enlarged and ulcerated, and the lymph-follicles of the mouth, pharynx, and base of the tongue affected to such a degree that Mosler<sup>5</sup> has described a leukæmic stomatitis and pharyngitis. A prominent seat of leukæmic change is the intestine, in which the solitary glands and Peyer's patches may present very marked hypertrophy. The cell-growth does not confine itself here to the adenoid

---

<sup>1</sup> Archiv d. Heilkunde, xi.

<sup>2</sup> Ponfick, Virchow's Archiv, lxxvii. 367.

<sup>3</sup> Osler, System of Medicine by American Authors, 1885, iii. 917.

<sup>4</sup> Verhandl. d. ärztl. Verein in Frankfurt, April 24, 1871.

<sup>5</sup> Die Path. u. Therap. d. Leukaemie, 1872, 182.

tissue proper, but may in advanced cases spread beyond it, forming large projecting and broadly-extending masses, which may ulcerate. The affection of the intestine is often so pronounced that an "intestinal leukæmia" has sometimes been described as one of the primary forms of the disease. Birch-Hirschfeld<sup>1</sup> does not consider this classification warrantable, in spite of the fact that, especially in childhood, leukæmia sometimes develops after intestinal catarrh.

A heteroplastic development of lymphadenoid tissue is not infrequently seen. These lymphomata are lymphoid new growths of local origin, consisting of a delicate reticulum containing leucocytes. They may occur, for example, in the larynx, trachea, bronchi, lung-tissue, pleura, thyroid gland, salivary gland, skin, suprarenal bodies, peritoneum, stomach, pancreas, brain, meninges, and heart. The lymphoid deposits in the retina have already been described. In the mucous membrane of the respiratory apparatus they often strongly resemble miliary tubercles, as was pointed out by Virchow. It is possible for these nodules to reach a considerable size, break down, and form cavities, thus presenting an appearance very like to that of phthisis.<sup>2</sup> Decided enlargement of both lachrymal glands in a leukæmic boy of four and one-half years has been reported.<sup>3</sup> The kidneys at times give evidence of leukæmic disease in the form of a pale-gray, spotted appearance in the cortex and fine gray lines between the rays in the pyramidal portion, while under the microscope are found fatty degeneration of the renal epithelium, a diffuse cellular infiltration, especially about the glomeruli, and a crowding of the capillaries with leucocytes. More rarely distinct lymphatic tumors can be observed.

By far the most common seat of heterologous lymphoid development, however, is the liver. In almost all advanced cases it is decidedly enlarged and is firm on section. The lymphoid new growth is in the form of a lymphatic infiltration, perceptible as a whitish line around the lobules, but penetrating also inward between the liver-cells, displacing and compressing them, and finally producing their fatty degeneration. The lymphoid cells lie partly within and partly around the capillaries. Less frequently large aggregations of these cells are seen, constituting definite, small, grayish-white, lymphoid tumors, the size of a miliary tubercle or larger.

Excepting the hemorrhages often to be found in different parts of the body, the only remaining characteristic post-mortem appearances to be noted are those depending on the condition of the blood within the heart and vessels. The heart usually contains a large amount of clotted blood, especially in the right side; and these clots have a greenish or yellowish color. The blood in the heart may so resemble pus that the impression may be given, as in a case of Virchow's, that an abscess has been opened. Similar clots

<sup>1</sup> Gerhardt's Handb. d. Kinderkr., 1878, iii. 1, 318.

<sup>2</sup> Böttcher, Virchow's Archiv, xxxvii. 63.

<sup>3</sup> Gallasch, Jahrb. f. Kinderheilk., 1874, vi.

occupy the larger and smaller veins, and the capillaries throughout the body may be distended with leucocytes. Softening of the brain may result from the thrombosis of the small cerebral vessels with white blood-corpuscles.

**Pathology.**—The disease consists in a change in the composition of the blood, depending on a hyperplasia of the blood-making tissue. How this change of composition is produced is still an unsettled question. On the theory that the red blood-cells are formed from the white, or mediately through the nucleated red blood-cells, the disease would appear possibly to be a failure on the part of the leucocytes to reach the perfect development of red blood-corpuscles; so that vast numbers of the latter are put forth into the circulation in an imperfect condition,—*i.e.*, as white blood-cells. Leukæmia, then, would be primarily a disturbance of the normal production of red corpuscles. This view is rendered more probable by the fact that not only are the leucocytes increased, but the colored cells are usually diminished in number. As the spleen, the lymphatic glands, and especially the red bone-marrow are usually regarded as the place of the production of the red blood-cells, the cause of the defective corpuscular formation is to be sought for in pathological changes occurring there. Directly connected with this subject is the custom of dividing the disease into splenic, lymphatic, and medullary leukæmia, according as the spleen, glands, or bone-marrow is the primary seat of the disease in certain cases. The question arises whether there actually exist any such different forms, and, if not, which of the three tissues is in reality the one primarily to be affected. Moxon<sup>1</sup> held the view that the spleen is the only starting-point of leukæmia, and that the great number of leucocytes found in the lymphatic glands and the marrow are only secondary deposits from the blood. The view is perhaps favored too by the readiness with which the bone-marrow appears to become affected in various anæmias, even of the non-cytogenic type. It appears to be very probable, however, that the medulla is often the primary seat of leukæmia, Neumann<sup>2</sup> even suggesting that this is the case in all instances. The subject is still very obscure, and needs further investigation.

Pure medullary leukæmia has been reported, but is rare. The combination of medullary and splenic disease constitutes the variety oftenest observed. Next in frequency is lieno-lymphatic leukæmia, consisting usually of a primary disease of the spleen with secondary involvement of the lymphatic glands. The pure splenic form is uncommon, and the pure lymphatic variety certainly rare. The theory has at various times been advanced that leukæmia is a primary disease of the *blood itself*, and that the lymphatic organs are secondarily affected.<sup>3</sup> Sprouck<sup>4</sup> claims that the

<sup>1</sup> Henry, *Anæmia*, 1887, 92.

<sup>2</sup> *Archiv d. Heilkunde*, 1870, xi. 12.

<sup>3</sup> Kottmann, *Die Symp. d. Leukaemie*, Bern, 1871; Lambl, *Il Tempo*, 1858; Variot, *Thèse de Paris*, 1882; Renant, *Archives de Physiologie*, 1881; Griesinger, *Virchow's Archiv*, v.; Biesiadecki, *Wien. Med. Wochenschr.*, 1876.

<sup>4</sup> *Centralbl. f. Klin. Med.*, 1889, August 31; also in *Ann. Univ. Med. Sci.*, 1890, ii. E.

leucocytes multiply in the circulation by kariokinesis, and compares the process to that going on in a neoplasm. He designates leukaemia "*leucocyphoma sanguinis*." Bard<sup>1</sup> goes so far as to call it "cancer of the blood." Other writers believe leukaemia to be a specific infectious disease, due to a microbe.<sup>2</sup>

**Complications and Sequelæ.**—Complications are unusual, the most frequent in children being the occurrence of a low form of pneumonia, which is often fatal. Among other complications occasionally seen are tuberculosis; parenchymatous nephritis; amyloid liver, kidneys, and intestine; fatty or cirrhotic liver; and inflammation of the serous membranes.

**Diagnosis.**—In well-advanced cases the diagnosis is easy, if the examination of the blood show the characteristic increase in the number of leucocytes. But the ratio of the white to the red cells varies considerably at different times in the same case, and repeated examinations of the blood must therefore be made in some instances. These will probably render the diagnosis clear, except in the early stages of the disease. At this period it may be confounded with leucocytosis, especially if this chance to be attended by a large amyloid spleen the result of suppuration, or by a cancerous mass in the neighborhood of this organ.

It has been stated<sup>3</sup> that one of the differences between leukaemia and leucocytosis consists in the fact that in the former there is, for the most part, a steady increase in the number of white blood-cells, while that of the red corpuscles is correspondingly diminished. In leucocytosis, on the other hand, the number of leucocytes varies greatly at different times, and the inverse ratio of red to white by no means obtains. This is, however, far from being an infallible rule, as shown by the case of Laache,<sup>4</sup> in which the number of red corpuscles was not materially diminished, although the leucocytes stood in the ratio of 1 : 17 with them. The diagnosis is rendered particularly difficult in children by the frequent combination in them of a high degree of leucocytosis with enlarged tubercular glands, or with the hypertrophied spleen of congenital syphilis. Undoubtedly some of the reported cases of leukaemia in children are spurious. Jaksch,<sup>5</sup> indeed, goes so far as to maintain that nearly all of them are so. He claims that there is in children a disease which he names "*anæmia infantum pseudoleukæmica*," characterized by very decided leucocytosis (1 : 20; 1 : 12) with enlargement of the spleen and lymphatic glands as seen in leukaemia, but without the proportionate enlargement of the liver which he deems a characteristic of it. The prognosis in the two affections is totally different. His observations are of great interest, but have not yet been confirmed and cannot be accepted as conclusive.

<sup>1</sup> Henry, Ann. Univ. Med. Sci., 1889, iv. J.

<sup>2</sup> Westphal, Berlin. Klin. Wochenschr., October 7, 1889; Mayet, Lyon Méd., 1888.

<sup>3</sup> Birch-Hirschfeld, Gerhardt's Handb. d. Kinderkr., 1878, iii. 1, 308.

<sup>4</sup> Die Anaemie, 1883.

<sup>5</sup> Ann. Univ. Med. Sci., 1890, ii. E; from Wien. Klin. Wochenschr., May 30, 1889.

The views of Ehrlich and of Jaksch regarding the eosinophilous cells afford a valuable diagnostic symptom in distinguishing the two conditions, if further investigations establish the pathognomonic importance of the cells.

Apart from the condition of the blood, leukaemia may be suspected from the existence of irregular pyrexia, progressing emaciation, and enlarged spleen or enlarged lymphatic glands, combined with a tendency to hemorrhage. In young children a rapidly-advancing splenic leukaemia might be confounded with typhoid fever, and the occurrence of intestinal hemorrhage would tend to confirm the mistake.<sup>1</sup>

Leukaemia is further to be distinguished from splenic anaemia, lymphatic anaemia, and sometimes from pernicious anaemia. In the early stages of many cases of leukaemia the diagnosis is of the greatest difficulty, and often becomes certain only when the number of leucocytes reaches a figure which places the nature of the case beyond doubt. Splenic anaemia often presents symptoms exactly similar to those of splenic leukaemia, apart from the difference in the composition of the blood. Hodgkin's disease, too, often closely resembles lieno-lymphatic or lymphatic leukaemia. In the non-leucocytic affection, however, the enlargement is generally much greater and the spleen is not much enlarged. That intermediate or transitional forms probably exist has already been stated. (See Classification of the anaemias.) In the case of the twins reported by Senator,<sup>2</sup> lymphatic anaemia existed for two months before the leukaemic condition of the blood developed.

Finally, it might not be possible to distinguish pernicious anaemia from the myelogenous form of leukaemia if the blood-affection of the latter were absent, and cases have already been referred to in which a transition seemed to take place from the former to the latter affection.

**Prognosis; Course.**—The prognosis of leukaemia is very unfavorable. Though there may be temporary arrest in its progress, or even improvement in the symptoms, the general course of the disease is onward to a fatal termination. In children the possibility of recovery is perhaps greater than in adults; yet out of thirty-nine cases occurring before adult life there are reported, according to Birch-Hirschfeld,<sup>3</sup> only four recoveries, and even these are not without question as to either the correctness of the diagnosis or the permanency of the cure. It seems at least certain that recovery is possible only in the early stages of the disorder. The progress of leukaemia is usually slow, and the affection lasts several years. In children the course is generally much shorter, and in proportion to the youth of the patient; and in some cases it has terminated within a few months. Golitzinsky<sup>4</sup> claims to have seen death occur in an infant after the disease had lasted but three weeks, and Eichhorst<sup>5</sup> reports the death of a boy after twenty-four

<sup>1</sup> Mosler, Berlin. Klin. Wochenschr., 1864, No. 12.

<sup>2</sup> Münch. Med. Wochenschr., January 21, 1890, 49.

<sup>3</sup> Gerhardt's Handbuch d. Kinderkrank., 1878, iii. 1, 333.

<sup>4</sup> Jahrb. d. Kinderheilk., 1861, iv. 90.

<sup>5</sup> Spec. Path. u. Therap., 1885, iv. 10.

days of illness. Epstein<sup>1</sup> even describes a distinct form—acute leukaemia—which lasts never more than nine weeks. It may begin quite suddenly, after a short prodromal stage of variable nature, consisting of intense headache, or slight fever, or respiratory symptoms, etc. In other cases it is preceded by severe anæmia.

The prognosis as to the duration in each individual case depends further on the rate with which the hyperplasia of the lymphadenomatous tissue advances, and on the percentage of leucocytes in the blood; though Fagge<sup>2</sup> attributes more importance to the degree of diminution of the number of red blood-cells, and to the intensity of the dyspnoea. Death generally takes place as the result of increasing exhaustion, and with hydræmic symptoms due to great anæmia. Hemorrhage from the nose, mouth, lungs, kidneys, bowels, or other parts, or into the brain, is often the immediate cause of death. Diarrhœa, too, may bring on the fatal termination, and pneumonia is a not infrequent cause of it in childhood, while other complications may in some cases be at fault.

**Treatment.**—The treatment of leukaemia is most unsatisfactory. Quinine and iron should be tried, given in large doses and for a long period, as good results have been claimed for them when administered in the early stages. Mosler<sup>3</sup> reports recovery in a boy of ten years under the use of this treatment; and this case is probably one of the most certain of the reported instances of recovery in children. He further<sup>4</sup> recommends piperin and oil of eucalyptus, on the ground that they produce contraction of the spleen. Arsenic in large doses should also be tried, as it has been claimed that success has been obtained with it. Injections of arsenic into the body of the spleen have also been recommended. Goodhart<sup>5</sup> reports improvement in six cases of possible leukaemia in children under the employment of cod-liver oil, phosphorus, or iodide of iron. Ergot internally or by injection, and the local employment of mercury, cold, and electricity, may be used, but little is to be expected from them. If there be any suspicion that congenital syphilis is the cause of the disease in a given case, a course of mercurial treatment should be instituted; though it is often valueless, and may even do harm. Transfusion of blood has been employed without much benefit. The ill results of extirpation of the spleen are seen in the twenty cases collected by S. W. Gross,<sup>6</sup> only one of which recovered, and in this the disease was in the incipient stages. The inhalation of large quantities of oxygen is a means of treatment which has recently come into prominence. Kirmberger<sup>7</sup> reports a case in a boy of ten and one-half years cured in this way. In other cases<sup>8</sup> marked temporary improvement has

<sup>1</sup> Deutsches Archiv f. Klin. Med., xliv.

<sup>2</sup> Practice of Medicine, 1886, ii. 349.

<sup>3</sup> Berlin. Klin. Wochenschr., 1864, No. 15.

<sup>4</sup> Ibid., 1876, No. 52.

<sup>5</sup> Fagge, Practice of Medicine, 1886, ii. 349.

<sup>6</sup> Medical News, 1887.

<sup>7</sup> Deutsche Med. Wochenschr., 1883, No. 41.

<sup>8</sup> Sticker, Zeitschr. f. Klin. Med., 1888, xiv. 80; Pletzer, Berlin. Klin. Wochenschr., 1887.



been obtained with it. Da Costa and Hershey<sup>1</sup> report two cases greatly improved by it; one of them being in a boy of thirteen years. Others, however,<sup>2</sup> have not succeeded in benefiting patients with oxygen. The diet and hygiene must, of course, be carefully attended to. Diarrhœa, vomiting, hemorrhage, and other disturbances call for treatment appropriate to them. The chief point to be borne in mind in this connection is the necessity of strict watch over, and perhaps of energetic treatment of, any case of chronic enlargement of the spleen or lymphatic glands in a child, lest it prove to be the prodromal stage of a leukæmia or other serious cytogenic disorder.

### SIMPLE CONSTITUTIONAL ANÆMIA.

**Definition.**—This condition may be defined as a cytogenic, non-leucocytic anæmia of moderate degree, due to some primary derangement of the blood-making organs without discoverable anatomical basis.

**Pathology.**—It has been questioned whether such an affection exists; and it is certain that many cases which might at first sight be assigned to this category will on more careful study be found to be symptomatic of some other disorder. Yet children after the first few days of life begin to be physiologically anæmic; and it is probable that many cases of anæmia in them merely exhibit a pathological exaggeration of this physiological disposition. An anæmia of this variety may even be congenital, occurring most frequently in the case of children who are born undersized and poorly developed, yet without the existence of any actual constitutional malady. Such are the children born often prematurely, or of delicate parents who yet have no discoverable disease. Henry<sup>3</sup> reports an interesting instance of congenital anæmia of this sort; the parents being immature, and the child weighing but six and three-fourths pounds and having only 3,625,000 red blood-cells to the cubic millimetre. The ratio of red to white cells equalled 1:145. In cases of constitutional anæmia there would seem to be “a congenital deficiency in the composition of the blood;”<sup>4</sup> “a congenital disproportion between the functionally active elements of the blood and the tissues of the body to be supplied by them.”<sup>5</sup> There perhaps exists in these cases an inborn inactivity of the hæmatopoietic system, producing a blood characteristic of anæmia. Treatment may remove the anæmic condition, or it may persist throughout the whole or a great part of the life of the individual. Again, though the child may not be anæmic at birth, there may be an inborn tendency to become so as growth advances, this being due in

<sup>1</sup> American Journal of the Medical Sciences, 1889, xlviii. 482.

<sup>2</sup> Schultze, Curschmann, Stintzing, Mosler; Münch. Med. Wochenschr., 1890, No. 2.

<sup>3</sup> Archives of Medicine, 1885, x. 102.

<sup>4</sup> Henry, Anæmia, 1887, p. 20.

<sup>5</sup> Immermann, Ziemssen's Handbuch d. Spec. Path. u. Therap., 1875, xiii. 1, 280.

some instances to an inability on the part of the blood-making organs to keep pace with the increase in the size of the body. A marked analogy is thus evident between the pathology of this affection and that of chlorosis.

Strümpell<sup>1</sup> believes that Virchow's explanation of the cause of chlorosis possibly applies to many cases of congenital anæmia, and Jacobi<sup>2</sup> says that he has seen a number of such cases in which the supply of blood to the body was diminished by the anomalous smallness of the heart and vessels. Strictly speaking, these cases cannot be included in this category, since they are really secondary to the anatomical condition, and have nothing to do with a functional inefficiency of the blood-making apparatus.

The **symptoms** of this type of anæmia do not differ from those usually found in the secondary forms already described.

The **diagnosis** rests on the early development of the anæmia secondary to no discoverable disease.

The **prognosis** tends to be unfavorable, since the cause is often a firmly-seated, constitutional one.

**Treatment** is similar to that recommended for the non-cytogenic varieties.

---

## SPLENIC ANÆMIA.

**Synonymes.**—Splenic anæmia, Anæmia splenica, Splenic cachexia, Splenic pseudo-leukæmia.

**Definition.**—Splenic anæmia is a cytogenic anæmia of pronounced degree depending on a decided enlargement of the spleen, and characterized by a marked diminution in the number of the red blood-cells without noteworthy increase in the number of leucocytes.

Although isolated cases of this nature have frequently been described, the disease has received little or no attention at the hands of most writers. It has, however, been discussed by Strümpell,<sup>3</sup> Henry,<sup>4</sup> and Banti,<sup>5</sup> among others.

**Etiology.**—The enlargement of the spleen appears to be the principal factor in producing the anæmia, but the cause of this enlargement cannot be discovered in all cases. Hypertrophy of the spleen is a constant attendant on profound malarial cachexia, and is also a prominent feature in hereditary syphilis. Barlowe and Bury<sup>6</sup> say that it is usually absent in rickets even when severe, and that, when present, it and the accompanying anæmia are not characteristic of rickets, but belong to a separate cachexia.

---

<sup>1</sup> Spec. Path. u. Therap., 1886, ii. 177.

<sup>2</sup> Archives of Medicine, 1881, v. 12.

<sup>3</sup> Archiv d. Heilkunde, 1877, xviii.

<sup>4</sup> Anæmia, 1887, 103.

<sup>5</sup> Ann. Univ. di Med. e Chir., Parte Rivista, 1883, cclxvi. 446.

<sup>6</sup> This Encyclopædia, ii. 231.

Although the anæmia attending these forms of splenic enlargement is often classified as symptomatic of the primary affections, yet it is too profound to be considered merely the result of the general effects of these upon the constitution. The blood-disorder owes its existence rather to the splenic affection itself,—*i.e.*, it is a splenic anæmia, and belongs to the cytogenic forms. This is shown by the fact that the anæmia does not develop to an intense degree in these diseases unless, and until, the spleen hypertrophies.

Splenic anæmia may occur in children of all ages as well as in adults. Eustace Smith<sup>1</sup> reports two interesting cases occurring in boys of twelve and nineteen months respectively, and, as early as 1856, Friedrich<sup>2</sup> published a carefully-studied case in a boy of five and three-fourths years. Smith considers the condition not infrequent in infancy and early childhood, and expresses the view that most instances of extreme anæmia in young children are of this nature.

**Symptoms.**—The symptoms begin insidiously with a progressive enlargement of the spleen, which often attains a great size. Anæmia develops simultaneously, and increases, producing at first symptoms similar to those of the non-cytogenic forms, which, however, later become extreme unless the disease is arrested. The tint of the face is characteristic, being in severe cases that of ivory or of yellow wax, with a faint olive color and a decided transparency.<sup>2</sup> Œdema and serous effusions are common in advanced cases, petechiæ and ecchymoses are also witnessed, and epistaxis is frequent. Emaciation may or may not be present, and is rarely extreme. Muscular prostration is intense. The bowels are easily affected, and the appetite in older children is diminished or perverted. Mental hebetude may be witnessed. There is often slight irregular pyrexia. The urine does not contain albumen.<sup>3</sup> The red blood-cells are greatly diminished in number, and resemble in appearance those seen in pernicious anæmia. Strümpell describes nucleated red blood-cells in blood from the pulmonary, hepatic, and splenic veins, though Banti says that they have never been seen in this affection. The white blood-cells are increased in number to some extent in certain cases, and not affected in others.

**Pathological Anatomy.**—Post-mortem lesions appear to be most marked in the spleen. This organ is much enlarged and hard, and is usually described<sup>4</sup> as of a deep-red color on section. Under the microscope the normal adenoid tissue is found to have largely disappeared, while the fibrous tissue has greatly increased in amount. There exist atrophy and sclerosis of the Malpighian bodies.<sup>5</sup> Fatty changes are visible in the heart and voluntary muscles. The marrow of the long bones may present

<sup>1</sup> Eustace Smith, *Diseases in Children*, 1884, p. 239.

<sup>2</sup> *Deutsche Klinik*, 1856, No. 22.

<sup>3</sup> Strümpell, *Archiv d. Heilkunde*, 1877, xviii.

<sup>4</sup> Wood, *American Journal of the Medical Sciences*, October, 1871; Ashby and Wright, *Diseases of Children*, 1889, p. 309.

<sup>5</sup> Banti, *loc. cit.*

in some cases the same dark-red lymphoid appearance frequently seen in pernicious anæmia.<sup>1</sup>

**Pathology.**—Splenic anæmia is sometimes described as the splenic form of Hodgkin's disease, and this is the opinion adopted by Banti. Others believe, with good reason, that it is entirely distinct from it. The distinction is based largely on the anatomical differences in the appearance of the spleen in the two affections. In splenic anæmia the appearance is as here described, while in Hodgkin's disease the characteristic change, and the one usually seen, is an hypertrophy of the Malpighian bodies, giving a variegated aspect to the section of the organ. Clinically, too, the affections are to be distinguished. I can recall two well-marked cases of splenic anæmia, seen within the last three years, occurring in a woman and a girl respectively, which seemed to bear but little resemblance to lymphatic anæmia either in symptoms or in course.

In the present state of our knowledge it is probably best to designate as splenic anæmia all those cases in which the anæmia appears to depend on enlargement of the spleen, whatever the cause of the hypertrophy may be, and in which there is no involvement of the lymphatic glands or leukæmic alteration of the blood.

**Diagnosis.**—The diagnosis rests upon the combination of extreme non-leucocytic anæmia with marked and uniform splenic enlargement without involvement of the lymphatic glands. Tumors of the spleen do not produce the symmetrical enlargement characteristic of the anæmic affection. Leukæmia is to be distinguished by the different character of the blood, Hodgkin's disease by the predominating involvement of the lymphatic glands, and pernicious anæmia by the absence of marked splenic enlargement.

**Prognosis.**—Ashby and Wright<sup>2</sup> say that most of the cases in children recover, and Eustace Smith,<sup>3</sup> though more guarded, does not give an unfavorable prognosis in all cases. It is probable, however, that permanent cures of splenic anæmia are of the rarest occurrence,<sup>4</sup> unless the splenic enlargement be due to syphilis or malaria. The disease is very apt to intermit, with periods of health lasting several months, during which time the splenic enlargement diminishes. The total duration of the disorder is from five or six months to three years.<sup>5</sup> Death in children is usually due to a severe attack of diarrhœa, or to the development of bronchitis or pneumonia.

**Treatment.**—The same internal constitutional treatment should be employed as has been recommended for the severe forms of non-cytogenic anæmia, and, besides this, especially unfavorable symptoms must be treated

<sup>1</sup> Henry, *Anæmia*, 1887, p. 105.

<sup>2</sup> *Disease of Children*, 1889, 309.

<sup>3</sup> *Disease in Children*, p. 240.

<sup>4</sup> Strumpell, *Archiv d. Heilkunde*, 1877, xviii, 112.

<sup>5</sup> Henry, *op. cit.*, p. 111.



of age; and states that the usual age at which children are attacked is from four to five years and upward.

Sex also appears to be an important factor, more boys than girls being affected: 75 of Gowers's 100 cases, and 40 of Hutchinson's<sup>1</sup> 58, were males.

**Symptoms.**—The symptoms may be divided into the regular or constitutional, and the accidental or secondary, these latter resulting from the pressure of the enlarged glands in different parts of the body. The disease further exhibits two periods or stages. Though it may in rare instances begin with a lymphomatous degeneration of the tonsils, yet the earliest symptom usually observed is a painless enlargement of the lymphatic glands, seen first, as a rule, in the neck. The swelling generally appears on one side first, and then spreads under the chin to the other side. This condition may remain unaltered for months or even for years, and during this first period of the disease there may be no constitutional symptoms of any moment, and the tumors remain isolated, painless on pressure, and movable under the skin. Sooner or later, however, the second period of the disease develops. The glands of the neck now rapidly increase in size and coalesce into large masses, and in most cases those of the axilla are also attacked, and less frequently those of the groin. The advancement of the disease to other parts of the body is attended or closely followed by a high grade of anæmia, emaciation, and prostration of strength. Some enlargement of the spleen may be detected at this stage, but great overgrowth is rather an unusual feature; though I have seen the organ in one instance, in a male adult, present a percussion-dulness extending downward from the nipple to the crest of the ilium, and horizontally from within an inch of the umbilicus to the normal dulness of the spinal region. An hypertrophy such as this is, however, very uncommon. Less frequently the more deeply situated glands of the body are involved, and may form huge masses in the abdomen and mediastinum. Sometimes, indeed, these glands may be the first to be attacked. The greater the degree of glandular involvement, the greater does the cachexia become.

Variations from the usual course of the disease may be witnessed. For example, the enlargement of the spleen may occasionally be discovered before that of the lymphatic glands,<sup>2</sup> though this is probably very exceptional. In other instances the deeper groups of glands may be first attacked, and the various pressure-symptoms may at first involve the true nature of the case in great obscurity. Sometimes, too, the anæmia and other constitutional symptoms develop before any local evidence of the affection can be found. In other cases, even when the glandular involvement is advanced, there may never be decided anæmia.

Fever is one of the most frequent symptoms. In the early stages it is slight; but when the disease is well under way it may be of an irregular,

<sup>1</sup> Transactions of the College of Physicians of Philadelphia, 1875, viii.

<sup>2</sup> Eichhorst, Spec. Path. u. Therap., 1885, iv. 17.

intermittent, hectic type, or continuous and high. Sometimes attacks of high fever are witnessed, lasting several days and accompanied by increased swelling of the glands.

Various other symptoms may be noted, some due to the anæmia, many to the enlargement of the glands or to the deposition of lymphatic tissue in various parts of the body. Among them are shortness of breath on exertion; palpitation of the heart; hoarseness from pressure on the pneumogastric or recurrent laryngeal nerve; more or less cough from pulmonary involvement, or from tracheal or bronchial stenosis; pleural or abdominal effusion from pressure on the veins, or from irritation of the serous membranes by lymphatic growths; diarrhœa or obstinate constipation; indigestion and vomiting; difficulty in swallowing; localized œdema from profound anæmia or from pressure; icterus from the growth of lymphatic tissue in the liver. Headache and dizziness may result from the anæmia, and neuralgias of various parts of the body may appear. There may be great apathy, dulness of mind, and indisposition on the part of the child to talk. Paralysis from pressure may be witnessed, as in the child of six years reported by Goodhart<sup>1</sup> and in a case of Hutchinson's.<sup>2</sup> Epistaxis is not as common as in leukæmia. Itching of the skin is frequent in advanced cases, and ulceration and hemorrhagic spots of various sizes may be present. Bronzing of the skin has been noted,<sup>3</sup> papular rashes may exist, and Wagner<sup>4</sup> has reported three cases of prurigo in lymphatic anæmia. It is a notable fact that the size of the enlarged glands may vary greatly from time to time in some patients.

The urine is usually not altered, but may occasionally contain albumen. In a child ten months old reported by Goodhart<sup>5</sup> the urine towards the end of the disease was red with blood.

The condition of the blood varies considerably in different patients. In the early stages it is usually entirely unaltered, and even after the glands in various parts of the body are affected the normal condition may persist. I have quite recently had under my care a patient in whom the submaxillary and parotid lymphatic glands on both sides were decidedly enlarged and were adherent to each other to some extent, while some of the superficial cervical and axillary glands were also involved. The blood, however, gave a hæmoglobin percentage of 90, and the red blood-cells numbered 5,920,000 to the cubic millimetre. Still, in general, as the disease advances the blood exhibits the characteristic lesions of an anæmia more or less severe. It is thin, pale, and watery, and coagulates slowly. The number of red blood-cells is often much reduced, but never as greatly as in many cases of pernicious anæmia. In a very severe case of lymphatic anæmia, with excessive

<sup>1</sup> Eustace Smith, *Diseases in Children*, 1884, 226.

<sup>2</sup> *Transactions of the College of Physicians of Philadelphia*, 1875.

<sup>3</sup> Osler, *System of Medicine by American Authors*, 1885, iii. 925.

<sup>4</sup> *Deutsches Arch. f. Klin. Med.*, Bd. xxxviii.

<sup>5</sup> Eustace Smith, *Diseases in Children*, 1884, 224.

hyperplasia of the lymphatic tissue, I still found 2,944,000 corpuscles to the cubic millimetre. Rarely there may be no reduction, even in advanced cases.

The white blood-cells are usually little if at all increased in number. Sometimes, however, they are greatly in excess, so that the disease actually approaches leukaemia and may even be apparently transformed into it. Poikilocytosis may be present to some degree. Microcytes are often abundant. Osler<sup>1</sup> has never found nucleated red blood-cells, and says that the number of blood-platelets is variable.

**Pathological Anatomy.**—In the early stages of the disease the lymphatic tumors are isolated and free from the skin, and exhibit simply an overgrowth of the glandular tissue, the natural appearance of the gland and the continuity of the capsule being preserved. In the later stages the glands may coalesce and form very large, irregularly-shaped masses, the lymphoid growth rupturing the capsule, and sometimes even spreading by continuity into the adjacent tissues, and perhaps, if superficial, ulcerating through the skin. There may also be true heteroplasic growths of adenoid tissue in different organs of the body.

The lymphomata, including the metastatic growths, are identical in nature with those seen in leukaemia. They may be of either the hard or the soft variety, according as the hyperplasia of the reticulum or that of the cells predominates. In the soft variety, which is much the more common, the glands may be even in an almost fluctuating condition. There is no sharp line of demarcation between the two forms, and a gland at one time soft may become hard, or the reverse may sometimes occur. On section the hard lymphomata are of a grayish-white, fibroid appearance, while the soft glands are of a grayish-red, marrow-like quality, and give a creamy juice when scraped. Under the microscope the soft form exhibits numerous cells like lymph-corpuscles, together with some giant-cells, but the reticulum can scarcely be seen. In the hard form the development of the reticulum varies proportionately to the hardness of the gland. The tumors may sometimes undergo an amyloid degeneration; more often they take on a fibroid induration, very seldom suppurate, and become caseous extremely rarely.

The superficial glands are those most generally involved, the cervical being oftenest attacked, and those of the axilla next. Of the internal glands those of the thorax are oftenest diseased. The retro-peritoneal glands are those in the abdomen most frequently hypertrophied.

Evidences of encroachment on different organs and of pressure in the most diverse localities may be found on post-mortem examination.

According to Gowers,<sup>2</sup> the spleen is hypertrophied or exhibits new growths of lymphatic tissue in about 75 per cent. of all cases, but the en-

---

<sup>1</sup> System of Medicine by American Authors, 1885, iii. 924.

<sup>2</sup> Reynolds's System of Medicine, 1879, v.



largement is generally not great. It is due either to a simple hyperplasia of the pulp, or more commonly to an extreme development of lymphatic tumors in the organ. These tumors are merely one or several united, greatly-hypertrophied Malpighian bodies. They vary in size from that of a pin's head to that of a walnut, and are of a white or yellowish color, in strong and characteristic contrast to the dark-red color of the splenic tissue. They are round or irregularly shaped, and may be one or two or very many in number. Histologically they are of the same structure as the hypertrophied lymph-glands. Resembling somewhat tubercular masses, they may be readily distinguished by the absence of any caseation, as well as, according to Langhans,<sup>1</sup> by the relative position of the reticulum and the cells in the two diseases; the cells occupying the centre of the nodule in the lymphoma, the connective tissue the centre in the tuberculous mass.

The marrow of the long bones has in a very few instances in adults been found red and lymphoid, as in the case reported by Ponfick.<sup>2</sup> Such a change has, I believe, not yet been found in children. In quite young children the marrow of all the bones is, of course, normally of this nature.

The thymus and thyroid glands, the suprarenal bodies, and the parotid glands have been reported involved. The tonsils and pharyngeal tonsil, and the follicles at the base of the tongue, are in some cases enormously hypertrophied. Lymphoid growths are sometimes seen in the stomach, and the small intestine may be similarly and very extensively affected and its walls much thickened. Ulceration of Peyer's glands may be the cause of diarrhœa. The large intestine also may be much involved. The liver is often enlarged and contains scattered small white lymphoid growths beneath the capsule or in the interlobular connective tissue; or there may be an interacinous lymphoid infiltration of the nature of an incipient cirrhosis. The pancreas at times contains lymphoid growths. The kidneys are enlarged in many cases, and exhibit a diffuse interstitial lymphatic growth, or a formation of distinct nodular masses. The testicles and ovaries, brain and spinal cord, are occasionally attacked. Lymphatic nodules frequently occur in the lungs, and resemble tubercular masses in appearance. They are found in greatest number about the bronchi. The heart may occasionally contain secondary lymphoid growths. It very often exhibits fatty change if the anæmia has been severe.

**Pathology.**—The pathological basis of the disease is a tendency to an overgrowth of lymphatic tissue throughout the body. This is almost invariably primary in the lymphatic glands, while the spleen is affected secondarily and to a much less degree, and the medulla of the bones but rarely. The tendency to generalization in many glands, together with the disposition to metastatic growths, renders it possible that the disease is of an infectious nature, and this view has been adopted to some extent. According

---

<sup>1</sup> Virchow's Archiv, liv. 525.

<sup>2</sup> Ibid., lvi. 550.

to Wunderlich<sup>1</sup> and others, the spleen may be primarily diseased, with secondary involvement of the glands. A classification has been made by some writers in which splenic, lymphatic, and medullary forms of the affection have been described, as in leukaemia; but the idea of pure splenic and medullary forms conflicts with the definition and the essential characteristic of the disease,—namely, an hypertrophy of the lymphatic glands. The first may be with much greater propriety referred to “splenic anæmia.” As to the second, it seems very possible that such a change in the bone-marrow is to be regarded as secondary to the anæmia, rather than as a cause of it; and in any case the nature and symptoms of this form of the disease could scarcely be distinguished from, if they be not, indeed, identical with, those of pernicious anæmia. (See Pernicious Anæmia.)

The relation of lymphatic anæmia to leukaemia is a very close one, and the lymphoid overgrowth does not essentially differ in the two affections. In leukaemia, however, the spleen and medulla of the bones are much more liable to be affected than are the lymphatic glands, and it is exceptional that the internal glands are much enlarged. The gross and microscopic appearances of the spleen in the two diseases are usually not alike; lymphomata in the organ being unusual in leukaemia, but very common in lymphatic anæmia. The difference in the character of the blood constitutes, nevertheless, the principal anatomical distinction between the two, and even this is not constant, since cases of transition from one to the other disease have been reported more than once. (See introductory remarks on Classification of anæmias.) The question has been raised whether any actual pathological difference exists.<sup>2</sup> It has been suggested<sup>3</sup> that the rapid growth of the lymphatic tissue in lymphatic anæmia did not allow time for the development of the leukaemic change in the blood; but this would not explain those cases in which the hyperplasia had always gone on slowly, yet no increase in the number of white blood-cells appeared. Fagge<sup>4</sup> takes the ground that the leukaemic condition of the blood is only an accidental circumstance complicating the overgrowth of lymphatic tissue. The remark of Birch-Hirschfeld<sup>5</sup> expresses accurately the state of the case,—viz., “that as long as we know as little of the etiology of malignant lymphoma as we do of that of leukaemia, the question as to the identity of or the difference between the two cannot be definitely determined.”

**Complications and Sequelæ.**—A scorbutic stomatitis has been witnessed as a complication of lymphatic anæmia. Diphtheria and dysentery have also occurred. Pleuritic effusion and œdema of the lungs are not uncommon, tuberculosis may develop, and catarrhal pneumonia is one of the

---

<sup>1</sup> Arch. f. Physiol. Heilkunde, 1866, 538.

<sup>2</sup> Langhans, Virchow's Archiv, liv. 512; Wood, Amer. Jour. Med. Sci., October, 1871; Pepper, *ibid.*, October, 1875.

<sup>3</sup> Cohnheim, Virchow's Archiv, xxxiii. 451.

<sup>4</sup> Practice of Medicine, 1886, ii. 352.

<sup>5</sup> Pathological Anatomy, 1883, ii. 131.

most frequent and fatal complications in children. Various affections of the skin, including bed-sores and furuncles, may arise, and erysipelas has been observed. Convulsions or coma may appear in the later stages.

**Diagnosis.**—The diagnosis, though usually easy, may at times present great difficulties, especially in the early stages of the disease. Lymphatic anæmia is to be distinguished in the first place from leukæmia, and this is to be accomplished mainly by the study of the blood, while, apart from this, leukæmia is much more apt to be attended by greatly-enlarged spleen, hemorrhages, and diarrhœa, and seldom exhibits the enormous glandular hypertrophy of the other affection. Lymphatic anæmia is further to be distinguished from local benign lymphomata and from lympho-sarcomata. The first of these is a simple but persistent hypertrophy of certain glands, and is of an entirely benign nature, without disposition to extend to other parts. The second is not uncommon in children, and may present difficulties in recognition. It is a localized, small-celled sarcoma of the lymph-glands, spreading by contiguity to the surrounding tissues, and undergoing metastases. The structures involved in the spread of the disease are organs rather than glands. There is not, in fact, the general involvement of one group of glands after the other, and of the lymphadenoid tissue throughout the body, as is the case in lymphatic anæmia. The affected gland is, moreover, sarcoma, and is usually adherent to the skin.

Scrofulous enlargement of the cervical glands is the condition most liable in children to be confounded with Hodgkin's disease, and in some cases cannot be distinguished from the early stages of the latter. Even later in the disease the diagnosis may be difficult, as scrofulous glands sometimes form masses as large as in advanced lymphatic anæmia. Yet other evidences of the scrofulous affection can usually be discovered, or there is a distinct family taint. The glands in scrofula are harder and less elastic, seldom so numerous, more often submaxillary than in the anterior and posterior triangles as in Hodgkin's disease, often early become adherent to each other and to the skin, and exhibit a decided disposition to suppurate.

**Prognosis ; Course ; Duration.**—The prognosis of lymphatic anæmia is almost uniformly unfavorable. There occurs a more or less rapid consecutive involvement of different groups of glands, with an advancing cachexia which sooner or later terminates in death from asthenia, unless the patient is carried off by some complication, as by catarrhal pneumonia, or by conditions arising through the pressure of the enlarged glands.

The duration of the disease varies from a few months to four or five years, depending largely on the rapidity with which the lymphoid hypertrophy advances and upon the position of the enlarged masses. Guitéras<sup>1</sup> reports the case of a child of five years, in whom the disease lasted but one month from the first enlargement of the cervical glands until death supervened. There may be periods during which the disease ceases to advance

---

<sup>1</sup> Ann. Univ. Med. Sci., 1888, i. 416.

and the tumors to increase in size. A few cases of recovery have been reported; as, for example, by Seitz<sup>1</sup> in an eight-year old boy. Henry<sup>2</sup> does not consider the prognosis so unfavorable as is usually supposed, particularly if the disease be recognized sufficiently early to permit of operative interference.

**Treatment.**—The most favorable hygienic conditions should be sought for the child as early as possible in the case. Cod-liver oil, iron, and quinine may be employed as general tonic measures, but are without specific action in arresting the growth of the glands. Iodine has been applied externally and injected into the tumors, and has also been given internally; and mercurial inunctions have been employed. Seitz's case recovered under the administration of iodide of potassium, digitalis, and finally of iron. Phosphorus has been advocated, and frictions and electricity locally applied have been claimed to be useful. Generally, however, all treatment is without avail, though there would appear to be more testimony to the value of arsenic than to that of any other drug. Its administration should be commenced early, and it should be given persistently and in as large doses as the child will bear. If the tumors be of small size and confined to one region, and have not been benefited by appropriate treatment, and if the general condition of the patient be good, the removal of the glands by operation is to be strongly recommended as offering the best chance for permanent cure. The earlier this operation is performed the better. Gowers<sup>3</sup> recommends that it be not performed on patients in whom the number of red blood-cells is below 60 per cent. of the normal. In case treatment directed against the disease is of no avail, a purely symptomatic method of procedure must be adopted. Tracheotomy or other surgical interference will sometimes be demanded for the relief of pressure-symptoms.

## PERNICIOUS ANÆMIA.

**Synonymes.**—Progressive pernicious anæmia, Idiopathic anæmia, Essential pernicious anæmia, Anæmatosis, Essential malignant anæmia, Essential febrile anæmia.

**Definition.**—An extreme and increasing anæmia without loss of flesh, not secondary to any discoverable adequate cause, and nearly always terminating in death.

**History.**—Though isolated instances were previously reported by Andral,<sup>4</sup> Coombe,<sup>5</sup> Hall,<sup>6</sup> Piorry,<sup>7</sup> and others, the first to describe a series of

<sup>1</sup> Deutsche Klinik, 1866, 145.

<sup>2</sup> Anæmia, 1887, 73.

<sup>3</sup> Reynolds's System of Medicine, 1879, v. 349.

<sup>4</sup> Clinique Médicale, 1823, iii. 535.

<sup>5</sup> Trans. Med.-Chir. Soc. Edin., 1823.

<sup>6</sup> Principles of Medicine, 1837, p. 207.

<sup>7</sup> Traité des Altérations du Sang, 1840.

cases was Channing in 1842.<sup>1</sup> In 1855, Addison<sup>2</sup> gave a clear account of the affection, under the title of "Idiopathic Anæmia." Renewed interest was awakened in the subject by the writings of Gussacrow<sup>3</sup> and of Biermer<sup>4</sup> in 1871 and 1872. Taylor<sup>5</sup> collected 23 cases which had been reported by various observers up to 1878. Since this time the number of published instances of the disease has greatly increased, and important contributions regarding it have appeared from the pens of Eichhorst,<sup>6</sup> Quineke,<sup>7</sup> Immermann,<sup>8</sup> Müller,<sup>9</sup> Lepine,<sup>10</sup> Osler,<sup>11</sup> Pye-Smith,<sup>12</sup> Pepper,<sup>13</sup> Mackenzie,<sup>14</sup> Musser,<sup>15</sup> and many others; including the valuable contributions to the pathology of the affection recently made by Hunter.<sup>16</sup> As the first instance in which the disease was seen in childhood may be designated one of the cases reported by Addison,<sup>17</sup> in a boy of sixteen years; or the still younger patient, a girl of eleven years, whose case is recorded by Leared.<sup>18</sup>

**Etiology.**—Locality has possibly some influence in the production of pernicious anæmia; the disease seeming to be more common in Switzerland and Northern Germany than in Southern Germany, Austria, England, France, and America; while in Italy, Russia, and the Spanish Peninsula it is rare.<sup>19</sup> Though not common in adults, it is still less often seen in children. Most cases appear between twenty and fifty years of age. The youngest case on record is said to have occurred in a girl of sixteen months.<sup>20</sup> Elben<sup>21</sup> reports it in a girl of three years, and Kjellberg<sup>22</sup> in a boy of five years. Other instances of its occurrence in persons under twenty years of age have been recorded by Quineke<sup>23</sup> (girl of eleven), Habershon<sup>24</sup> (girl,

<sup>1</sup> New England Quarterly Journal of Medicine, 1842.

<sup>2</sup> "Constitutional and Local Effects of Diseases of the Suprarenal Capsules."

<sup>3</sup> Arch. f. Gynäkol., 1871, ii. 2, 218.

<sup>4</sup> Correspondenzbl. f. Schweiz. Aerzte, 1872, ii. No. 1.

<sup>5</sup> Guy's Hospital Reports, 1878.

<sup>6</sup> Die Progressive Perniciöse Anämie, 1878.

<sup>7</sup> Volkmann's Samml. Klin. Vorträge, No. 100; Deutsches Arch. f. Klin. Med., xx., xxv., xxvii., xxxiii.

<sup>8</sup> Deutsches Archiv f. Klin. Med., xiii.; Ziemssen's Handb. d. Spec. Path. u. Therap., 1875, xiii. 1.

<sup>9</sup> Die Progressive Perniciöse Anämie.

<sup>10</sup> Rev. Mens. de Méd. et de Chir., 1876, 129.

<sup>11</sup> System of Medicine by American Authors, 1885, iii. 898.

<sup>12</sup> Guy's Hospital Reports, 1883, 219.

<sup>13</sup> American Journal of the Medical Sciences, October, 1875.

<sup>14</sup> Lancet, 1878, ii. 797, 833.

<sup>15</sup> Proc. Phila. County Med. Soc., 1885.

<sup>16</sup> Lancet, 1888, ii. 555, 608, 654; Practitioner, August, 1888, September, November and December, 1889.

<sup>17</sup> Guy's Hospital Reports, 1857, iii. 207.

<sup>18</sup> Path. Trans., 1858, ix. 438.

<sup>19</sup> Eichhorst, Spec. Path. u. Therap., 1885, iv. 32.

<sup>20</sup> Stinzing, quoted by Ashby and Wright, "Diseases of Children," 1889, p. 310.

<sup>21</sup> Ashby and Wright, op. cit.

<sup>22</sup> Nordisk Medicinsk Archiv, xvi., No. 13, 1.

<sup>23</sup> Volkmann's Samml. Klin. Vorträge, 1876, No. 100, 814.

<sup>24</sup> Taylor, in Guy's Hospital Reports, 1878.

fifteen), Kahler<sup>1</sup> (boy, twelve), Cayley<sup>2</sup> (boy, seven), Mackenzie<sup>3</sup> (boy, ten), Huguenin<sup>4</sup> (girl, eight), Gull<sup>5</sup> (boy, age not given), Biermer<sup>3</sup> (girl, eighteen), Haven<sup>6</sup> (girl, ten), and Bradford<sup>7</sup> (girl, eleven).

Of 102 cases collected by Pye-Smith only 6 were less than fifteen years of age, and 4 were between fifteen and twenty.

Statistics indicate that females are more predisposed to the disease than males. In this estimation are included the cases developing after parturition. If these be omitted, as parturition is itself a predisposing cause, the influence of sex appears to be immaterial. The number of cases which have occurred in children is too small to allow of conclusions being drawn; though rather more female than male children have suffered from the disease.

A lack of proper hygienic conditions and insufficient nourishment may possibly have a slight predisposing influence, yet this appears by no means certain. Pregnancy and parturition, common predisposing causes in adults, of course need not be considered in this connection. Bodily over-exertion or exposure, the previous occurrence of some acute disease, anæmias of other forms, gastric and intestinal disturbances, mental or nervous shock, etc., have in different cases immediately preceded and perhaps predisposed to the affection; in the case of Gull referred to, the boy had been greatly frightened by being attacked by sheep in a field. Where there has been profuse hemorrhage or diarrhœa preceding the anæmia, it is questionable whether this can be classed as pernicious anæmia, but is not rather to be considered a secondary form. Yet if the condition of the blood grows steadily worse after the apparent cause has been removed, the preceding anæmia can be looked upon as a predisposing cause of pernicious anæmia. It is always to be borne in mind in considering the etiology of pernicious anæmia that the essential feature of this affection is its origin without adequate discoverable cause apart from some as yet unknown alteration of the blood-making apparatus or direct destruction of the blood itself.

Klebs<sup>8</sup> reported the occurrence of species of *Cercomonas* in the blood, and Frankenhäuser<sup>9</sup> that of micrococci, but it is uncertain whether these possess any etiological relation to the affection. Kjellberg<sup>10</sup> believes that the disease is probably an infectious one, and the possibility of this being the case is strengthened by the fact that it appears epidemically to a certain degree in Switzerland. Very many cases do not offer even a predisposing factor in explanation of their development.

<sup>1</sup> Pye-Smith, in Guy's Hospital Reports, 1883.

<sup>2</sup> Coupland, in British Medical Journal, 1881, i. 550.

<sup>3</sup> Lancet, 1878, i. 13.

<sup>4</sup> Müller, Die Progressive Perniciöse Anämie.

<sup>5</sup> Mackenzie, Lancet, 1878, ii. 833.

<sup>6</sup> Archives of Pediatrics, December, 1884.

<sup>7</sup> Boston Medical and Surgical Journal, July, 1876.

<sup>8</sup> Real Encyclopædie, article "Flagellata."

<sup>9</sup> Centralbl. f. d. Med. Wissensch., 1883, No. 4.

<sup>10</sup> Nordisk Medicinsk Archiv, xvi., No. 13, 1.

**Symptoms.**—Pernicious anæmia usually comes on so insidiously that the date of onset can scarcely be determined. At first there simply appear increasing pallor, weakness, shortness of breath, and other evidences of anæmia. When the disease is well established, the color of the skin is often a striking one, being not ashen, but of a pale-lemon tint, simulating jaundice. The conjunctivæ may have a similar hue. This peculiar shade of the skin has been repeatedly referred to by authors, and is very characteristic when well marked. The subcutaneous fat is very rarely diminished, and is not uncommonly increased in amount. Slight œdema of the extremities and face may occur, and petechiæ may develop. The mucous membranes are very pale, the tongue is swollen and dry, and the bones are sometimes tender on pressure.

The pulse is often peculiarly full, but very compressible. Palpitation of the heart comes on with the slightest exertion. Anæmic murmurs of various sorts are often heard over the heart,—sometimes so loud that they simulate organic murmurs, especially as they may be accompanied by a distinct thrill. The cardiac dulness, however, indicates a heart of normal size or but slightly dilated, unless hydro-pericardium has developed. A systolic murmur may be heard in the arteries, and a loud venous hum in the jugulars.

Dyspnoea is often very great on the slightest exertion, and is sometimes persistent. Hydrothorax may come on near the end of life. Ringing in the ears and dizziness are evidences of the anæmia, and debility may be so great that the patient is confined to bed, and cannot sit upright on account of the symptoms of cerebral anæmia which this movement produces. The development of the hemorrhagic diathesis is a frequent symptom of the disease. Epistaxis is very common, and is sometimes among the earliest symptoms; and hemorrhages from the bowels or the gums may exceptionally occur. Retinal hemorrhages are present in the majority of cases, and may impair vision.

The appetite is usually lost, and an atonic state of the digestion, with diarrhoea, nausea, and vomiting, is very frequent. In most cases there is fever of an irregular type, usually with an evening rise of from 2° to 4° F. or even more. Sudden falls of temperature during the twenty-four hours are sometimes seen. A peculiarity of the temperature consists in the occurrence of periods of apyrexia lasting several days or weeks. Towards the close of life there is a tendency to fatal collapse, with great depression of temperature.

The urine is of low specific gravity, and generally contains more uric acid than normal. Statements regarding the excretion of urea vary. Albuminuria is rarely seen. In a case recently reported by Hunter<sup>1</sup> the urine was of a deep sherry-color, and contained a large amount of pathological urobilin. He considers that this substance, renal epithelium, and perhaps

---

<sup>1</sup> Practitioner, September, November, December, 1889.

a few casts containing blood-pigment, together with an increased excretion of iron, are features of the urine which, when present, are characteristic of pernicious anæmia. This same dark color of the urine was remarked repeatedly in a patient under the care of Pye-Smith;<sup>1</sup> and Henry,<sup>2</sup> Mott,<sup>3</sup> and others have also noticed it. Mott<sup>4</sup> has recently reported a second case, in which the same dark color was observed, and an excess of urobilin determined with the spectroscope.

There may be no symptoms pointing to the brain, except that answers to questions are often given only after a long pause, as though thinking were done slowly. Either sleeplessness or an unnatural tendency to sleep may be present. Delirium is occasionally witnessed.

Lichtheim<sup>5</sup> has reported three cases in which the symptoms of tabes accompanied those of pernicious anæmia, and believes that the combination is of common occurrence. Lepine, too,<sup>6</sup> has seen wide-spread atrophic paralysis develop in pernicious anæmia. I have recently seen a case of the disease in the practice of Dr. W. H. H. Githens, of Philadelphia, in which evident nervous symptoms were present, consisting in tingling and a subjective sense of coldness in the extremities, especially the legs and feet, and diminution of the power of walking, apparently not due to loss of strength.

The ratio of the weight of the blood to the total weight of the body has been calculated to be much diminished in pernicious anæmia, and its specific gravity also less (1028.2, Quinke). When drawn from the finger it appears strikingly pale and watery, and often scarcely enough can be expressed to permit of accurate examination. It coagulates very slowly. The amount of fibrin is diminished. The number of red blood-corpuscles is very greatly reduced, often more than in any other form of anæmia. A count of 1,500,000 or 1,000,000 represents an average case, while a reduction to even 500,000 has been repeatedly though less frequently witnessed. In a case reported by Quinke<sup>7</sup> the number of red cells equalled 143,000 per cubic millimetre. Macrocytes are generally stated to be numerous; while a photograph published by Henry<sup>8</sup> and here reproduced indicates that a majority of the red blood-corpuscles may be greatly increased in size. Eichhorst,<sup>9</sup> too, states that the average size of the red blood-cells in pernicious anæmia equals 8.9 instead of 7.6 micro-millimetres as in normal blood. Microcytes are nearly always present, and the small, round, and deeply-colored forms have been described<sup>10</sup> as very commonly seen, though some observers have not always found them.<sup>11</sup>

<sup>1</sup> Guy's Hospital Reports, 1883, xxvii.

<sup>2</sup> Personal communication.

<sup>3</sup> Lancet, March 16, 1889; Ann. Univ. Med. Sci., 1890, ii. E.

<sup>4</sup> Lancet, 1890, i. 287.

<sup>5</sup> La Semaine Méd., 1887; Münch. Med. Wochenschr., 1890, No. 3.

<sup>6</sup> Rev. de Méd., 1887.

<sup>7</sup> Deutsches Archiv f. Klin. Med., xx.

<sup>8</sup> Anæmia, 1887, 119.

<sup>9</sup> Spec. Path. u. Therap., 1885, iv. 36.

<sup>10</sup> Eichhorst, loc. cit.

<sup>11</sup> Henry, Anæmia, 1887, 125.



Poikilocytosis of very marked degree is seen to greater advantage in pernicious anæmia than in any other condition. The red blood-cells lie

FIG. 9.

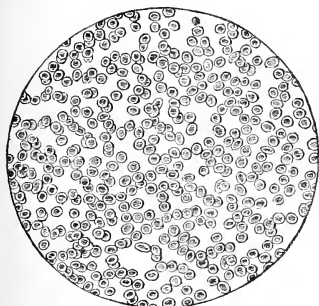

Photograph of normal blood.

FIG. 10.

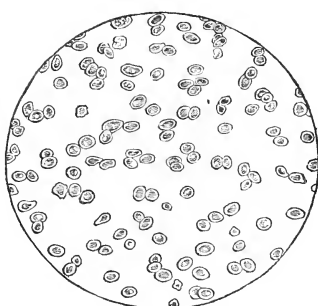

Photograph of blood in pernicious anæmia.

singly or in poorly-formed rouleaux. Nucleated red cells have been only occasionally described, though Ehrlich<sup>1</sup> claims that they are nearly always present in all forms of severe anæmia; and Neumann<sup>2</sup> also has found them in severe post-hemorrhagic cases. The hæmatoblasts are absent or very few in number.<sup>3</sup>

The ratio of the number of leucocytes to that of the red cells may be normal or diminished, or sometimes decidedly increased. It has been noticed that the hæmoglobin readily crystallizes out of the red blood-corpuscles in this disease.<sup>4</sup>

A very important characteristic, to which attention has repeatedly been called by writers, is the relatively high percentage of hæmoglobin present. In other forms of anæmia the percentage of hæmoglobin is generally much smaller than that of the red blood-cells, but in pernicious anæmia it nearly equals or very commonly exceeds it to some extent, so that the hæmoglobin value of each corpuscle is actually greater than normal. Laache<sup>5</sup> views it as almost pathognomonic of pernicious anæmia, and Hunter<sup>6</sup> says that this condition of the hæmoglobin is the only strictly characteristic feature of the blood in this disease, as all the others referred to may be present to some extent in other conditions, though he<sup>7</sup> believes the very great reduction in the number of red cells is usually a prominent symptom. Henry<sup>8</sup> believes that the altered relation is due partly to the abnormally large size of the corpuscles, and partly to the fact that the microcytes are not usually counted in estimating the number of red blood-cells present.

<sup>1</sup> Berlin. Klin. Wochenschr., 1880, 405.

<sup>2</sup> Zeitschr. f. Klin. Med., 1881, iii. 414.

<sup>3</sup> Osler, System of Medicine by American Authors, 1885, iii. 902.

<sup>4</sup> Copeman, Lancet, May 28, 1887.

<sup>5</sup> Die Anämie, 1883.

<sup>6</sup> Practitioner, 1889.

<sup>7</sup> Practitioner, 1888, 93.

<sup>8</sup> Anæmia, 1887, p. 125.

**Pathological Anatomy.**—The cadaver appears well nourished, but the skin is intensely pale and often has the peculiar lemon-tint referred to. Some degree of œdema of the extremities and face is often present, and petechiæ are not uncommonly observed; but all traces of cadaveric lividity and of ecchymoses are usually absent. The subcutaneous fat is abundant. The muscles are pale, or sometimes of an intense deep-red color.<sup>1</sup> The mucous membranes are very pale. The internal organs exhibit an intense anæmia and strongly-marked fatty degeneration. Punctiform or larger hemorrhages are very common in all of the viscera. Moderate effusion into the serous cavities is frequent, and may be hemorrhagic in character. The heart is of normal size or slightly dilated, and contains an unusually small quantity of thin, fluid blood. Its muscle-substance is pale, and exhibits patches of fatty degeneration beneath the endocardium, especially in the left chambers and on the papillary muscles of the mitral valve. The intima of the blood-vessels may also exhibit fatty degeneration. The orifices and valves are usually normal. Cases have been described in which there was found an abnormal narrowness of the arteries. The lungs exhibit no changes beyond the great anæmia, the frequent presence of hemorrhagic spots, and the occurrence of some œdema at their bases. The gastro-intestinal mucous membrane may exhibit œdema and hemorrhage and fatty degeneration of the glands. Atrophy of the gastric mucous membrane has been described in some cases, and I have seen one typical example of it. This may be secondary to the pernicious anæmia, possibly a complication, or possibly a cause of a grave symptomatic anæmia closely resembling pernicious anæmia in its clinical symptoms.

Fatty degeneration and atrophy of the nerve-plexuses of the intestine, probably of a secondary nature, have been described by Jürgens<sup>2</sup> and Sakaki.<sup>3</sup> The pancreas has been found swollen and exhibiting fatty degeneration and hemorrhages. The liver is frequently fatty and sometimes enlarged; it may contain hemorrhages; and Lebert<sup>4</sup> describes the occurrence of leucin and tyrosin in it. The gall-bladder is often very full of bile. The kidneys are pale and show fatty degeneration. The suprarenal bodies have been smaller than normal in some instances.

The brain and spinal cord are extremely anæmic, the cerebral convolutions wasted, and capillary hemorrhages into the white substance often present. The amount of cerebro-spinal fluid is often greater than normal. Hemorrhages may frequently be found on the inner surface of the cerebral dura mater. Lichtheim<sup>5</sup> found the spinal cord intact in no case of pernicious anæmia examined by him. Either small sclerotic foci, the result of minute hemorrhages, were present, or wide-spread degeneration in the pos-

---

<sup>1</sup> Osler, *System of Medicine by American Authors*, 1885, iii. 904.

<sup>2</sup> Berlin. *Klin. Wochenschr.*, 1882, No. 28.

<sup>3</sup> *Virchow's Archiv*, xvi. 287.

<sup>4</sup> *Handb. d. Allgem. Path. u. Therap.*, 1876, 73.

<sup>5</sup> *Münc. Med. Wochenschr.*, 1890, No. 3.

terior columns, extending into the neighboring parts. He believes the degeneration to be secondary to the extreme anemia.

Alterations of the semilunar ganglion have been described by Brigidi,<sup>1</sup> consisting of an increase of the interstitial connective tissue and of the nuclei, and fatty degeneration of the nerve-fibres and ganglion-cells. Osler,<sup>2</sup> however, found nothing abnormal in two cases. It is doubtful whether the pathological changes in the sympathetic system have any essential connection with the disease.

Retinal hemorrhages have been already referred to as of very frequent occurrence.

Of the organs of the hæmatopoietic system, the spleen may contain hemorrhages and infarcts, but is of normal size or only slightly enlarged. Leucin and tyrosin have been found in it,<sup>3</sup> and nucleated red blood-corpuscles have been observed.

The lymphatic glands are generally normal in appearance. Weigert<sup>4</sup> and Osler<sup>2</sup> have reported cases in which they were of a deep-red color on section, and the former has described nucleated red blood-corpuscles in glands of this character.

The tissue to which the greatest attention has been directed is the marrow of the bones. In many cases the fatty marrow of the long bones of adults is replaced by a red marrow. This change was first described by Wood<sup>5</sup> and afterwards by Pepper;<sup>6</sup> and Cohnheim<sup>7</sup> is inclined to regard it as the specific cause of the disease. There is often, too, a great increase in the number of nucleated red blood-cells. In other instances, however, the marrow has been found of normal appearance.

A feature of the morbid anatomy which has recently sprung into renewed importance is the increase of the amount of iron in various organs, but especially in the liver. In 1876, Quineke found a great increase of iron in the liver in three cases of pernicious anæmia, as shown both by microscopical and chemical examination. This observation was soon after confirmed by Rosenstein.<sup>8</sup> Later Quineke and Peters<sup>9</sup> noticed that this increase was nearly a constant feature. That it is not due to the administration of iron and its subsequent deposition in the liver was shown by the experiments of several investigators.<sup>10</sup> Peters found that the amount of iron may be slightly increased in various diseases other than pernicious anæmia. Hunter has made an extensive and exhaustive study of the subject, and discovered a great excess of iron in the liver in nine cases of pernicious anæmia.

<sup>1</sup> London Medical Record, 1878, 430; from *Lo Sperimentale*, May, 1878.

<sup>2</sup> System of Medicine by American Authors, 1885, iii. 905.

<sup>3</sup> Lebert, *Handb. d. Allgem. Path. u. Therap.*, 1876, 73.

<sup>4</sup> Virchow's Archiv, lxxix.

<sup>5</sup> American Journal of the Medical Sciences, October, 1871.

<sup>6</sup> *Ibid.*, October, 1875.

<sup>7</sup> Virchow's Archiv, 1876, lxxviii. 291.

<sup>8</sup> Berlin. Klin. Wochenschr., 1877, 113.

<sup>9</sup> Deutsches Archiv f. Klin. Med., xxxii.

<sup>10</sup> Kobert, *Arch. f. Exper. Path. u. Pharmak.*, xvi. 390; Cahn, *ibid.*, xviii. 146; Glavecke, *ibid.*, xvi. 469.

The iron shows itself in the form of altered blood-pigment, occupying the outer and middle zones of the liver-lobules, while the inner circle exhibits only fatty degeneration. This peculiar distribution appears to be characteristic of pernicious anaemia, since in some other affections, in which also the amount of iron is increased, there is no such regularity in its distribution. He regards the excess of iron and the manner of its distribution in the liver as the only constant anatomical lesion to be met with in this disease.

My own observations are not sufficiently extended to justify any conclusions. In three cases I have detected in the liver a great increase of pigment containing iron, and distributed in the manner described. The liver of one of these cases is shown in Plate III., Fig. 11, and more highly magnified in Fig. 12. In a fourth case, however, which during life appeared to be a typical instance of pernicious anaemia, there was no increase whatever of iron. The sections had been in alcohol for some years before being prepared, and I do not know whether it is possible that this long immersion could have dissolved out the pigment. In no other condition, so far as my observations extend, could an increase be recognized, except in one instance,—a curious combination of hepatic cirrhosis, typhoid fever, and ulcerative endocarditis, in which there was during life distinct evidence of a destruction of blood within the system. In this case, however, the increase was but slight, and the pigment exhibited no regularity of distribution.

The method of examination consists in immersing the sections for ten or fifteen minutes or longer in a freshly-prepared solution of ferrocyanide of potassium, and then transferring them, for a few moments only,—with a camel's-hair brush, *not* with a needle,—to a very dilute solution of hydrochloric acid. A well-marked Prussian-blue reaction is thus developed with the iron present. Microscopical examination discloses deeply-stained granules lying within the hepatic cells of the outer and middle zones.

Another method consists in the employment of a fresh solution of sulphide of ammonium, as this darkens all the tissue containing iron. The value of these methods depends on the fact that iron, as contained in ordinary haemoglobin, does not respond to these reagents, and that it is only after the haemoglobin has been set free, and has undergone a chemical modification into some other form of blood-pigment, that the blue or black color is produced.

Chemical analyses of the spleen made by Rosenstein,<sup>1</sup> Stahel,<sup>2</sup> each in one case, and by Hunter<sup>3</sup> in nine cases, have shown no marked increase of iron in it. Russell,<sup>4</sup> using simply the micro-chemical method, reports a decided increase of iron in this organ in a case of the disease, the pigment being situated mainly in the walls of the pulp-sinuses.

There is sometimes a deposition of pigment-granules in the kidney, confined entirely to the primary and secondary convolutions of the convo-

<sup>1</sup> Berlin. Klin. Wochenschr., 1877, 113.

<sup>2</sup> Virchow's Archiv, lxxxv. 26.

<sup>3</sup> Lancet, 1888, ii.

<sup>4</sup> British Medical Journal, 1889, i. 70.

PLATE III

Fig. 11.

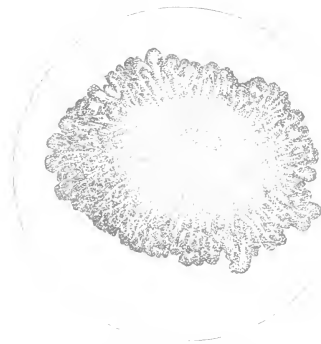

LIVER LOBULE FROM CASE OF PERLE'S ANEMIA, SHOWING DENSE ARRANGEMENT OF IRON PIGMENT WITHIN CELLS, SUPPLYING A CHARACTERISTIC APPEARANCE.

Fig. 12.



CELLS FROM LIVER IN PERLE'S ANEMIA, MORE THINLY SPREAD, SHOWING DENSE DARK IRON PIGMENT WITHIN CELLS, SUPPLYING A CHARACTERISTIC APPEARANCE.

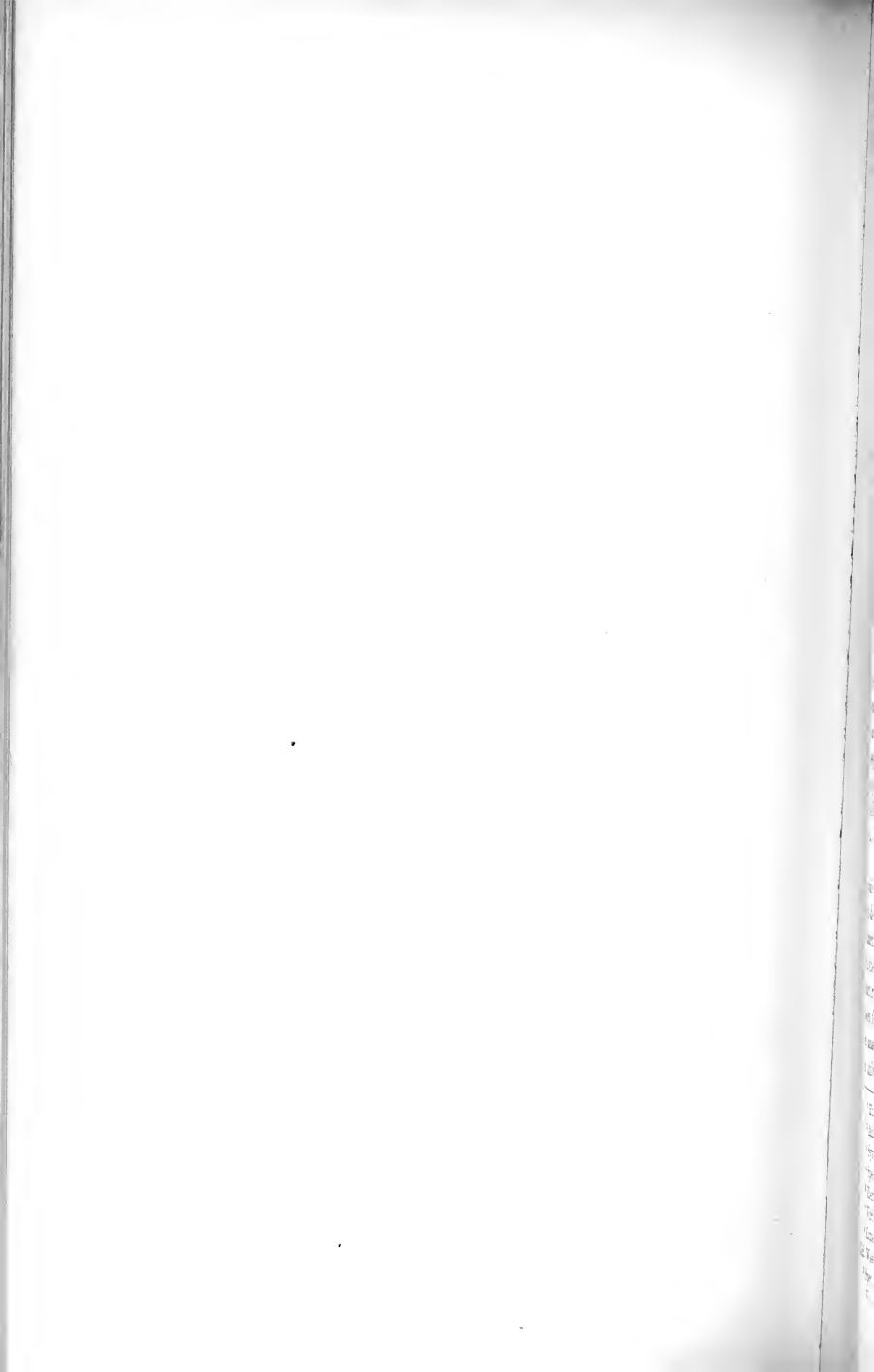

luted tubules.<sup>1</sup> The loops of Henle are comparatively free, and the collecting tubes and the glomerules show no trace of pigment.

**Pathology.**—Whether or not pernicious anæmia is a distinct pathological entity is still a much-disputed question. Henry<sup>2</sup> takes the ground that it is the final stage of several forms of symptomatic anæmia and of chlorosis. The earlier view of Quinke, too, was that pernicious anæmia is merely an anæmia which grows steadily worse and ends fatally. His later view was that the disease has a clinical but no pathological existence. Osler's<sup>3</sup> division of it into groups depending on differences in the pathological anatomy expresses a similar belief. Eichhorst<sup>4</sup> and Coupland<sup>5</sup> divide it into primary and secondary forms. Many writers, on the other hand, believe in the independence of the affection, and, like Immermann,<sup>6</sup> are of the opinion that the so-called instances of the transition of chlorosis or other anæmias into pernicious anæmia are not such, but rather cases in which the latter affection has developed as a complication of the preceding one. Hunter is one of the strongest of the more recent supporters of the independence of the disease, and has done much to establish this. He shows very conclusively that such conditions as the presence of intestinal worms, atrophy of the gastric mucous membrane, and malignant disease, to all of which the disease has been ascribed, are repeatedly met with in cases presenting none of the appearances of pernicious anæmia; and, conversely, that cases of pernicious anæmia are repeatedly seen in which no such changes are to be found. These facts, in connection with the clinical symptoms, but especially with the characteristic condition of the blood during life, and the equally pathognomonic change in the liver found after death, justify the belief that the disease is an independent one due to some cause not operating in other forms of anæmia.

The nature of this cause is another subject still very obscure. The view which has been most commonly accepted is that the blood-changes are due to defective hæmogenesis,—*i.e.*, the affection is to be classed as a cytogenic anæmia. This opinion has been based largely on the changes often found in the bone-marrow, and Cohnheim<sup>7</sup> assumes these as the specific etiological factor. In many instances, however, the marrow of the long bones has been found unaffected, while the characteristic change has been discovered in anæmia of other forms, and has even been produced experimentally in animals by repeated bleedings.<sup>8</sup> Hunter and Eichhorst<sup>9</sup> share the

<sup>1</sup> Hunter, Practitioner, September, November, December, 1889.

<sup>2</sup> Anæmia, 1887; Medical News, October 5 and 12, 1889.

<sup>3</sup> System of Medicine by American Authors, 1885, iii. 905.

<sup>4</sup> Spec. Path. u. Therap., 1885, iv. 32.

<sup>5</sup> Lancet, 1881, i. 571.

<sup>6</sup> Ziemssen's Handb. d. Spec. Path. u. Therap., 1875, xiii. I. 645.

<sup>7</sup> Virchow's Archiv, lxxviii. 291.

<sup>8</sup> Litten, Orth, Berlin. Klin. Wochenschr., 1877; Bizzozero, Salvioli, Centralbl. f. d. Med. Wiss., 1879.

<sup>9</sup> Spec. Path. u. Therap., 1885, iv. 44.

belief that the condition of the bone-marrow is purely secondary,—an evidence of an effort made by the hæmogenic tissue to make up by over-production for the great destruction of the corpuscles. If, now, the bone-marrow be not at fault, we are bound to consider the possibility of the disease being a consumption of the blood, as suggested by Immermann,<sup>1</sup>—that it consists in a direct destruction of red blood-corpuscles, perhaps due to some infectious agents.<sup>2</sup> The exhaustive studies of Hunter are worthy of careful consideration in this connection. This author takes the ground that the excretion of urine of dark color and low specific gravity, containing pathological urobilin; the evidence of an increased secretion of bile, as shown by the dark color of the feces and the presence of a large amount of bile of dark color in the gall-bladder; the lemon-color or slight jaundiced hue of the skin; and the occurrence of large amounts of altered blood-pigment in the liver, are proofs that a great destruction of the red blood-cells has been going on. He regards the disease as a hæmolytic anæmia. The process differs from that producing hæmoglobinuria in that in the latter affection the disintegration of corpuscles occurs in the general circulation, and the hæmoglobin is excreted as such; while in pernicious anæmia it is carried on in the portal circulation, especially the spleen and liver, and the hæmoglobin set free is carried to the liver and there transformed into an altered blood-pigment and deposited in the liver-cells, or excreted as bile-pigments, producing a polychoelia. This increased flow of bile is followed by an increased consistency of it, and this by a stagnation in the bile-ducts; and the attacks of jaundice or the persistence of a slight icteric tint so common in pernicious anæmia are probably to be accounted for in this way. It is possible that the jaundice in some cases may be hæmatogenous. Hunter thinks there is no doubt that the pathological urobilin in the urine is derived, through the medium of the bile-pigments, from the disintegration of hæmoglobin. Hæmoglobinuria does not occur in this disease; but, when the amount of hæmoglobin set free is too great to be disposed of by the liver, it passes through the organ into the general circulation, and is apparently thrown down in granular form within the epithelial cells of the kidney in the process of being excreted. He considers the cause of the blood-destruction to be certain poisons, probably of a cadaveric nature, absorbed from the intestinal tract. This last assumption as to the cause of the hæmolysis seems to demand further proof; although it has been shared by some writers,<sup>3</sup> and two cases are reported<sup>4</sup> which would seem to favor it, prompt recovery having followed the employment of lavage of the stomach. Hunter admits that in some other affections, as cirrhosis

<sup>1</sup> Ziemssen's Handb. d. Spec. Path. u. Therap., 1875, xiii. l. 644.

<sup>2</sup> Strümpell, Spec. Path. u. Therap., 1886, ii. 197.

<sup>3</sup> Roosevelt, Medical Record, April 14, 1888; Trechsel, Rev. Méd. de la Suisse Romande, June 20, 1888.

<sup>4</sup> Sandos, Ann. Univ. Med. Sci. 1889, iv. J, 9; Meyer, Correspondenzbl. f. Schweiz. Aerzte, June 1, 1889.



of the liver, chronic venous congestion, and malaria, there may also be a deposit of pigment in the liver, but shows that the seat of the deposition is different. The total absence or slight degree of the iron-reaction in the spleen is to be explained on the ground that, though the blood-pigment is liberated in that organ, it remains hæmoglobin until it reaches the liver, and consequently gives no reaction for iron with the tests employed. Russell,<sup>1</sup> however, does not admit that the liver is the chief seat of the altered blood-pigment in pernicious anæmia, as he has found an increased amount of it in the spleen as well.

Still another view of the nature of the disease has been advanced,<sup>2</sup>—namely, that, although there is undoubtedly a greatly-increased hæmolysis in pernicious anæmia, this occurs on account of *defective hæmogenesis*, which makes the red corpuscles abnormally prone to perish. This theory appears very plausible, especially as the assumption of a cadaveric poison is not altogether satisfactory. In the present state of our knowledge, however, we can scarcely go further than to consider pernicious anæmia a hæmolytic anæmia, the blood-destruction being due to causes unknown; and, as we are not able to prove that it is related in any respect to defective hæmogenesis, it seems best to assign it provisionally to the non-erythrogenic group of anæmias.

**Diagnosis.**—The diagnosis of pernicious anæmia rests on the existence of an extreme and progressing anæmia without evident cause; the absence of emaciation; the peculiar lemon-tint of the skin; the occurrence of hemorrhages; the presence of irregular fever; the condition of the urine, if present, and the characteristic alteration of the blood, this last consisting in decided microcythæmia and poikilocytosis, a very high degree of oligocythæmia, and a relatively large proportion of hæmoglobin. Post-hemorrhagic anæmia, even when severe, does not exhibit the characteristic blood-changes. The urine, too, is usually pale, in contradistinction to the high-colored urine of pernicious anæmia. The secondary anæmias due to cachectic conditions are usually accompanied by wasting. Pure cases of chlorosis are characterized by the condition of the blood peculiar to that disease,—*i.e.*, great loss of hæmoglobin without proportionate diminution in the number of corpuscles. Chlorosis is not infrequently complicated by anæmia, and there is no reason why pernicious anæmia should not be engrafted upon it. This might account for the statement of Bristowe,<sup>3</sup> that it is impossible at the present time to make any trustworthy distinction between the two diseases, except such as depends on the age and sex of the patient and the effects of treatment.

Most of the cases of anæmia attributed to atrophy of the gastric mucous membrane have shown some degree of wasting. Ordinary cases of leukæ-

<sup>1</sup> British Medical Journal, January, 1889, i. 70.

<sup>2</sup> Russell, *ibid.*; Henry, Medical News, October 5 and 12, 1889; Purser, Ann. Univ. Med. Sci., 1890, ii., E, from *Dubl. Jour. Med. Sci.*, May 1, 1889; Mackenzie, British Medical Journal, May 4, 1889.

<sup>3</sup> British Medical Journal, 1888, i. 1149.

mia, splenic anæmia, and lymphatic anæmia offer no difficulty in diagnosis. A pure medullary form of the latter must be considered as pernicious anæmia in which the marrow is affected.<sup>1</sup> Myelogenous leukaemia in the early stages may simulate pernicious anæmia, but the examination of the blood after the disease is advanced should settle the matter. Anæmia due to the presence of intestinal parasites may resemble pernicious anæmia very closely, but may sometimes be detected by the discovery of worms or ova in the fæces.

**Prognosis; Course; Termination.**—The prognosis of pernicious anæmia is most unfavorable. The duration varies from a few weeks to months or rarely years. Statistics do not show that it is more rapidly fatal in children than in adults. Temporary improvement may be witnessed, but the disease is liable to recur. The fatal termination is generally due to the progressing anæmia and consequent debility, with delirium or apathy before death. Pye-Smith<sup>2</sup> gives a table of twenty recoveries, but none of them were in patients under nineteen years of age. Some of these are very probably instances of errors in diagnosis.

**Treatment.**—As the name of the disease implies, treatment is almost always useless. Proper hygienic and dietetic measures are essential. All dyspeptic symptoms are to be combated with the greatest diligence, and the appetite and strength of the patient maintained by tonics and easily-digested and nourishing food. Defibrinated blood and the prepared beef foods may be found useful, given either by the mouth or rectum. The hypodermic injection of defibrinated blood has even been recommended, and an instance of recovery under this treatment reported.<sup>3</sup> Predigested nourishment will be indicated when the digestive powers seem weak. Cod-liver oil, phosphorus, iron, and arsenic may be given, the latter being the drug on which by far the greatest reliance can be placed. As children bear large amounts of it, the dose should be gradually and steadily increased until the limit of tolerance is reached. Iron is not generally of much value. The unirritating preparations, such as the malate, lactate, albuminate, etc., should be selected if the stomach of the child is delicate. When no other treatment avails, transfusion of blood may be tried, but with doubtful benefit.

---

## ADDISON'S DISEASE.

**Synonymes.**—Morbus Addisonii, Melasma suprarenale.

**Definition.**—A constitutional or blood disease characterized by extreme and progressing loss of strength, great debility of the circulation, irritability of stomach, and generally by pigmentation of the skin. In most cases there

---

<sup>1</sup> Birch-Hirschfeld, *Patholog. Anatomie*, 1883, ii. 1, 153.

<sup>2</sup> Guy's Hospital Reports, 1883, xxvi.

<sup>3</sup> Westphall, *Ann. Univ. Med. Sci.*, 1890, ii. E.

are degenerative lesions of the suprarenal bodies, usually of a fibro-caseous nature; and in many instances there are changes in the abdominal sympathetic.

As already stated, the disease can with propriety be referred to the constitutional disorders, or it may be considered here, on the ground that the suprarenal bodies are members of the hæmatopoietic apparatus.

**History.**—Addison<sup>1</sup> in 1855 gave a clear exposition of the connection of changes in the suprarenal bodies with the symptoms of the disease which bears his name. Previously to this, in 1849, he had announced his discovery to a medical society.<sup>2</sup> Isolated cases had been reported before this time by Schotte<sup>3</sup> and Bright;<sup>4</sup> and since Addison's publication many cases have been recorded, though the affection still remains a comparatively rare one. The case of Schotte's occurred in a girl of fifteen years, and was typical, except that it exhibited no discoloration of the skin. Risel and Greenhow nevertheless consider it a good instance of the disease. Among the valuable articles written on the subject are those of Wilks,<sup>5</sup> Virchow,<sup>6</sup> Averbeck,<sup>7</sup> Bamberger,<sup>8</sup> Gerhardt,<sup>9</sup> Risel,<sup>10</sup> Jaccoud,<sup>11</sup> Greenhow,<sup>12</sup> Burger,<sup>13</sup> Monti,<sup>14</sup> Merkel,<sup>15</sup> Osler,<sup>16</sup> and numerous others, to which full acknowledgment is here made for information and statements drawn from them.

**Etiology.**—The causes of the disease are unknown. Anxiety, care, unfavorable hygienic surroundings, chronic constipation or diarrhoea, malaria, injuries of the abdomen, etc., have been assigned as predisposing causes in different cases, but it is doubtful whether any of them exert any decided influence. Traumatism of the abdomen has perhaps a little more evidence in favor of its etiological connection with the disease. Persons with a predisposition to phthisis do not appear to be more liable to it than do others. The laboring classes are especially prone to be attacked. The influence of heredity is undetermined. Sex is a strongly predisposing factor, many more males than females having suffered from the disease. Greenhow analyzed 183 cases, of which 119 were males and 64 females; Jaccoud collected the

<sup>1</sup> "On the Constitutional and Local Effects of Diseases of the Suprarenal Capsules."

<sup>2</sup> London Medical Gazette, 1849, p. 517.

<sup>3</sup> Halle Hosp. Reports, 1823.

<sup>4</sup> Medical Reports, 1831, ii. 247.

<sup>5</sup> Reynolds's System of Medicine, 1879, v. 363; also Guy's Hospital Reports and Transactions of the Pathological Society.

<sup>6</sup> Krankhafte Geschwülste, 1864-5, Bde. ii., iii., and 1867.

<sup>7</sup> "Die Addison. Krankh.," 1869.

<sup>8</sup> Krankh. d. Chylo-poiēt. Syst., 1864, 2. Aufl. 662.

<sup>9</sup> Lehrb. d. Kinderk., 1881, 579.

<sup>10</sup> Deutsches Archiv f. Klin. Med., 1870, vii.

<sup>11</sup> Dictionnaire de Médecine.

<sup>12</sup> "On Addison's Disease," 1875; also Transactions International Congress, 1881, ii. 59

<sup>13</sup> "Die Nebenn. u. d. Morb. Addison.," 1883.

<sup>14</sup> Gerhardt's Handb. d. Kinderk., 1878, iv. 3, 499.

<sup>15</sup> Ziemssen's Handb. d. Spec. Path. u. Therap., 1875-80, viii. II. 283.

<sup>16</sup> System of Medicine by American Authors, 1885, iii. 939.

records of 79 males and 48 females with it, and Averbeck 80 males and 46 females. Age, too, is an important factor. The majority of cases occur between the ages of fifteen and forty-five years. In old age and before that of ten years it is exceedingly rare. Out of an analysis of 290 cases Monti<sup>1</sup> found but 11 instances of its occurrence in children under fifteen years. Of these 1 child was aged three years, 1 was aged from ten to eleven years, 3 children were aged twelve years, 1 child was aged thirteen years, and 5 children were aged fourteen years. 8 of the children were boys, and 3 girls. Gerhardt<sup>2</sup> has collected 17 cases in children before the fifteenth year. Besides these Monti<sup>3</sup> has also described another case in a boy of ten years, and Courteen<sup>4</sup> one in a boy of sixteen years. Baginsky<sup>5</sup> quotes Legg and Pye-Smith as having reported cases in boys of fifteen and fourteen years respectively. Probably the youngest case on record is that reported by Belaieff,<sup>5</sup> in a male child seven days old when first seen, who died fifty-three days later with the characteristic symptoms of the malady.

**Symptoms.**—The disease begins with languor, weakness, and indisposition to bodily or mental exertion, arising without apparent cause, and steadily progressing and becoming excessive. The heart-muscle gradually shares in the asthenia, and the heart's action becomes remarkably feeble. A discoloration of the skin develops usually after the asthenia has lasted some time, though occasionally it is the first symptom noticed. Severe digestive disturbances arise, and grave nervous symptoms may terminate the life of the patient.

Looking at the symptoms more in detail, the alteration of the skin presents itself as the most striking. There is noticed in most cases a gradually increasing pigmentation, at first light yellow, sometimes a greenish-brown or bronzed tint, or perhaps finally almost black. In typical cases the whole surface of the body is discolored more or less uniformly, but certain parts are more deeply pigmented than others; these being the more exposed portions of the body, as the face, the neck, and the backs of the hands; those which have been subjected to pressure, as the waist or the leg from the pressure of a garter; and those which naturally contain considerable pigment, as the areolæ of the breasts, the external genitals, the axillæ, and the flexor surfaces of the joints. In many cases the pigmentation is but slight, and not at all universal. It is not to be regarded as an essential feature of the disease, as many cases have been reported in which it was absent, not only in the rapidly fatal cases, in which there might not have been time for it to develop, but in those as well which had run a more chronic course. The mucous membranes may also become pigmented. That

---

<sup>1</sup> Gerhardt's *Handb. d. Kinderkr.*, 1878, iv. 3, 499.

<sup>2</sup> *Lehrb. d. Kinderkr.*, 1881, 580. Writers mentioned.

<sup>3</sup> Baginsky, *Lehrb. d. Kinderkr.*, 1887, 759.

<sup>4</sup> *Wien. Med. Wochenschr.*, 1887.

<sup>5</sup> *Med. Oboz. Moskov.*, 1886, in *Ann. Univ. Med. Sci.*, 1888, i. 474.

of the mouth may exhibit scattered patches of a very dark color upon the under surface of the tongue, on the palate, and on the gums and the inside of the cheeks and lips. The vagina may be very deeply discolored. The conjunctivæ are rarely affected. The hair, scalp, soles of the feet, nails, and palms of the hands are generally uninvolved. In the case of a child of three years reported by Pitman,<sup>1</sup> the body was covered with a considerable growth of black hairs.

Emaciation is not a characteristic of Addison's disease, though it may occur. Anæmia, too, is not a symptom of it,<sup>2</sup> as even in advanced cases the lips and gums are not bloodless, and the common symptoms of anæmia not often witnessed. The blood is often rich in red corpuscles, and there is no increase of leucocytes.<sup>3</sup> The feebleness of the circulation is remarkable. The pulse is weak, small, accelerated, thready, and often almost imperceptible. The apex-beat of the heart is weak; murmurs are generally absent. The respiration is slightly accelerated, but not generally interfered with in other respects unless complications arise. Attacks of dyspnoea are sometimes observed. The temperature is normal, or very frequently subnormal, except in the very acute cases, in which there may be high fever. Digestive disturbances are characteristic of the affection, and usually appear early in children. They consist in loss of appetite, vomiting or nausea, eructations, cardialgic attacks, annoying hiccough, and, on the part of the bowels, abdominal tenderness and constipation or obstinate and not infrequently fatal diarrhœa. The urine is usually pale and free from albumen. According to Gerhardt, there may be polyuria. The amount of uræa may be greatly reduced, and that of indican increased, and in one case Thudichum found the amount of uromelanin much less than normal.<sup>4</sup> Gerhardt and Reichardt<sup>5</sup> discovered traces of taurocholic acid and large amounts of fatty acids in the urine. In a case reported by Nothnagel, and which I had the opportunity of examining, the fatal ending came on suddenly, with mental excitement, delirium, and finally coma; a very large amount of acetone appearing in the urine at the same time.

The most characteristic and constantly present symptoms of Addison's disease are those of the nervous system. Chief of these is the great asthenia,—the complete prostration both of mind and of body, without any other cause than a lack of nervous energy. The prostration finally becomes so extreme that the patient cannot sit upright, the voice becomes weak, and the limbs tremble when raised.

Among other nervous symptoms may be mentioned the frequent and

---

<sup>1</sup> *Lancet*, 1865, i. 175.

<sup>2</sup> Wilks, *Reynolds's System of Medicine*, 1879, v.; Osler, *System of Medicine by American Authors*, 1885, iii.

<sup>3</sup> Greenhow, "On Addison's Disease."

<sup>4</sup> Osler, *loc. cit.*

<sup>5</sup> Eichhorst, *Spec. Path. u. Therap.*, 1885, ii. 622.

sometimes early occurrence of pain in different parts of the body ; as headache, and pain in the back and abdomen and in the limbs. The pain in the joints may simulate that of rheumatism. Tenderness on pressure in the lumbar region is often noticed, and is probably due in many cases to the formation of abscesses in front of the spinal column. Pain would appear to be a little less constant symptom in children, as Monti found it in only three of the eleven cases analyzed by him.

As the disease advances the intelligence grows dull, the memory weak, and sleepiness or delirium may be observed. Attacks of fainting, dizziness, dyspnoea, or palpitation become more frequent, and are evidently due to the nervous disturbance rather than to anæmia. Maniacal attacks have been witnessed. Coma or convulsions may supervene and perhaps produce the sudden death of the patient. Children are particularly liable to exhibit convulsions of varying intensity, from slight twitching of the muscles to well-marked epileptoid convulsions. Gerhardt states that two-fifths of the cases collected by him suffered from convulsions.

**Pathological Anatomy.**—The fatty tissue of the body is not materially diminished in amount ; the muscles are not pale. The skin presents the dark discoloration described. On microscopical examination there is found an increase of the pigment in the deeper layers of the cells of the rete, and, in well-marked cases, in the papillary layer of the cutis and even in the connective-tissue cells. It does not differ in nature and arrangement from the pigment seen in the skin of the negro.

The most interesting pathological change is that occurring in the suprarenal bodies. By far the most constant lesion presented by them is a fibro-calcareous condition. They are much larger than normal, hard on section, irregular and often nodular in shape, and frequently adherent to surrounding structures. The normal tissue of the gland is replaced by a firm, somewhat translucent, homogeneous substance, in which are embedded yellowish or grayish, cheesy nodules of the size of a pea or larger. These masses may either be transformed into calcareous nodules or may undergo softening and form pus. In the early stages of the disease the tissue of the gland is, according to Wilks, nearly or entirely replaced by the homogeneous substance referred to. The cheesy foci develop later, and in advanced stages may completely substitute the homogeneous material first deposited.

Microscopical examination shows the translucent substance to be composed of fibrous tissue, either in a young or a more advanced condition. The yellow nodules consist of masses of detritus. When degeneration has not become complete in them, they exhibit a growth of small cells contained in a delicate reticulum. Giant cells are sometimes present. The lesions are very similar to local tubercular affections. Tubercular bacilli have been found in many cases, but not discovered in probably as many others.

The fibro-calcareous change is not, however, the only one which has been found in Addison's disease. Carcinoma has occurred in rare instances, and produced the symptoms of the affection. This is said to have been the case

in the child of three years recorded by Pitman.<sup>1</sup> Sarcoma of the suprarenals with the symptoms of Addison's disease has been reported. Simple atrophy of the capsules has also been present in this disease, as have amyloid degeneration, interstitial hemorrhages, or gummata in them.

The condition of the abdominal sympathetic is a matter of great importance. The semilunar ganglia have exhibited a hyperplasia of the connective tissue in a number of cases, with degeneration and pigmentation of the nerve-cells. The nerves leading from the ganglia have been found degenerated in some cases, and in others normal. Jürgens<sup>2</sup> claims that a gray degeneration of the splanchnic is present in a large proportion of the cases, whether or not there has been disease of the capsules.

Of the other organs of the body the heart has been found very small in some instances, and its muscle degenerated to some extent. The spleen and thymus gland are sometimes enlarged. The lymphoid elements of the intestine, as seen in the solitary glands and in Peyer's plaques, are very commonly swollen, and ulcers in the ileum may be present, and the lymphatic glands of the retro-peritoneum and the mesentery may also be swollen and perhaps cheesy. Lymphoid deposits have been observed in the stomach. The lungs are tubercular in a large number of cases, and the bronchial glands cheesy.

**Pathology.**—As we do not know the function of the suprarenal bodies, we cannot well understand the pathology of Addison's disease. Osler gives a lucid exposition of the chief of the different theories which have been suggested. These are—

1st. The view of Addison,—that the disease is directly dependent on a destruction of the capsules and the consequent cessation of their functions. According to this view, the pigment accumulates in the blood, it being the function of the glands to destroy a substance in the blood which is readily converted into pigment. Taylor<sup>3</sup> believes that the pigmentation is induced by the destruction of the cortical portion of the gland, and the nervous symptoms by the involvement of the central portion, as this is in such close relation with the nerve-structures. The objection to this theory is that cases are reported in which the suprarenal bodies exhibit no change, and that removal or destruction of the bodies in animals is not followed by the symptoms of the disease.

2d. The belief that the disorder is an affection of the abdominal sympathetic, induced usually by disease of the suprarenal bodies, but also by other affections. This theory is accepted by probably the majority of writers, and would seem to explain the symptoms better than any other. While there are many arguments in its favor, there are certain powerful objections to it. It is, namely, uncertain what the changes in the sympathetic ganglia

---

<sup>1</sup> *Lancet*, 1865, i. 175.

<sup>2</sup> *Deutsche Med. Zeitung*, May 10, 1888.

<sup>3</sup> *New York Medical Journal*, 1856.

and nerves are in many cases; and in others it seems quite positive that no pathological changes at all existed in them. It is also difficult to understand why the symptoms of Addison's disease are not produced in the many instances in which the semilunar ganglia are very greatly implicated by other affections than disease of the suprarenal bodies. Thus, in aneurism of the abdominal aorta and retro-peritoneal cancer no bronzing of the skin is, as a rule, observed.

3d. The view, for which there is no good support, that the disease is due to some poisonous agent introduced from without, or the result of imperfect metabolism.

4th. A theory allied to the first,—that the blood is gradually poisoned by the retention of some material the destruction or alteration of which it is the function of the suprarenal bodies to effect. From this point of view the disease is analogous to chronic uræmia.

In any case it does not seem justifiable to assume, as Wilks and others have done, that that only can be called Addison's disease in which the degeneration of the glands is of a fibro-caseous nature. Rather is the affection not a definite anatomical disease so much as a peculiar aggregation of symptoms.<sup>1</sup> If it depends solely on a lesion of the suprarenal bodies, this lesion might well be of any nature which would accomplish their destruction. If, on the other hand, it is due to a disturbance of the function of the abdominal sympathetic, there would seem to be no reason why this must depend on a lesion of the suprarenal bodies alone.

**Complications and Sequelæ.**—The only one deserving of notice is tuberculosis of various organs, which is of very common occurrence. Oppenheim<sup>2</sup> reports a case complicated by exophthalmic goitre.

**Prognosis; Course; Duration.**—The prognosis is absolutely unfavorable, if the diagnosis of the disease has been correctly made. Gull<sup>3</sup> and Finney<sup>4</sup> report cases of recovery. The course of the disease is onward until life is terminated slowly and quietly by the asthenia. Sometimes convulsions, syncope, coma, or diarrhœa cut the affection short. Tubercular complications are very seldom the cause of death. The duration of the disease is very variable. The course may be very acute and resemble that of typhoid fever to some extent. In such cases the affection begins with high fever, vomiting, diarrhœa, and excessive prostration, which rapidly grow worse until death occurs in a few weeks or months. In other cases this rapid course may change into a more chronic one, and in still others it may be chronic from the beginning, and the patient live for several years. Temporary remissions occur and last some months, during which time there is either improvement or cessation in the progress of the symptoms.

**Diagnosis.**—The diagnosis is easy if there be present the combination

<sup>1</sup> Strümpell, *Spec. Path. u. Therap.*, 1886, ii. 96.

<sup>2</sup> *Deutsche Med. Zeitung*, December 29, 1888.

<sup>3</sup> *Transactions of the International Medical Congress*, 1881, ii. 75.

<sup>4</sup> *Dublin Journal of Medical Science*, 1882, lxxiii. 293.



of the nervous symptoms with the coloration of the skin. Pigmentation of the skin alone is not, however, a diagnostic symptom. It may be quite deep and intense in abdominal growths, but is not usually so uniform as in Addison's disease. In tubercular peritonitis, however, it may be very marked.<sup>1</sup> In hepatic diseases spots of pigment are often seen about the face. A wide-spread pigmentation has been reported in persons suffering from melanotic growths, and might render a diagnosis uncertain.<sup>2</sup>

The pigmentation of pregnancy and of uterine disease does not, of course, come into consideration in a work of this nature. In persons of uncleanly habits the irritation of pediculi may cause a pigmentation resembling that of Addison's disease, but the presence of the parasites or of the scratches and the white cicatrices should make the diagnosis plain. Argyria is known by the history; intense icterus by the condition of the conjunctivæ; cyanosis by the disappearance of the color on pressure.

**Treatment.**—Treatment, except that directed to the symptoms, is useless. Absolute rest is to be enjoined, to avoid the danger of syncope. The best of food and the employment of stimulants are indicated to support strength, and tonic drugs may be given for the same purpose. Diarrhœa and vomiting need treatment appropriate to them. Arsenic, strychnine, iron, cod-liver oil, phosphorus, quinine, have all been recommended, and may accomplish temporary good. Morphine will be needed in some cases. Strong purgative medication should never be given to relieve constipation, as there is danger of collapse following. Galvanism, counter-irritation, and the administration of iodide of potassium or syrup of the iodide of iron ought to be tried.

---

## INFECTIOUS HÆMOGLOBINÆMIA OF THE NEWLY-BORN.

**Synonymes.**—Epidemic hæmoglobinuria of the new-born (Birch-Hirschfeld), Acute hæmoglobinæmia of the new-born (Hirst), Cyanosis afébrilis icterica pernicioso cum hæmoglobinuria (Winckel), Epidemic hæmoglobinuria with icterus in the new-born (Runge), Maladie bronzée hématique des nouveau-nés (Laroyenne and Charrin), Tubulhématie rénale (Parrot), Maladie bronzée hématurique des nouveau-nés (Bar and Grand'homme), Winckel's disease.

**Definition.**—An acute and usually epidemic affection of the blood, developing in the newly-born, characterized by cyanosis, icterus, and hæmo-

---

<sup>1</sup> Osler, *System of Medicine by American Authors*, 1885, iii.; Mussey, *Étude sur la Pigment. de la Face dans la Tuberc. abdomin.*, 1879.

<sup>2</sup> Wagner, *Archiv d. Heilkunde*, 1864, v. 280; Legg, *Trans. Path. Soc. London*, 1884, xxxv. 367.

globinuria, running a rapid course and ending fatally in almost every instance.

**History.**—In 1871, Pollack<sup>1</sup> gave a brief report of twelve sporadic cases which he had observed within the year, and which would appear very probably to be instances of the disease under consideration, though none of them are individually described.

In 1873, Laroyenne<sup>2</sup> described an epidemic of the disease which occurred in the Maternity Hospital at Lyons, and in which fourteen infants were attacked; and his pupil, Charrin, later made the affection the subject of a thesis.<sup>3</sup> Very shortly after Laroyenne, Parrot<sup>4</sup> reported two cases seen by him not occurring at the same time. Two years afterwards, in 1875, Bigelow<sup>5</sup> gave an account of an epidemic seen in the Boston Lying-in Hospital, in which ten infants were affected. In 1877, Herz<sup>6</sup> published two cases which he denominated “acute fatty degeneration of the new-born,” but which appear to be doubtless instances of the disease now under consideration.

By far the fullest description of the malady is that of Winckel,<sup>7</sup> in 1879. Twenty-four children in the Dresden Maternity Hospital were attacked by it in the course of little more than one month. He called it a “hitherto undescribed endemic disease of the newly-born;” and it is probably on this account that the disorder has usually and unjustly gone by his name. Some additional remarks on its pathological anatomy, based on some of these cases, were afterwards published by Birch-Hirschfeld.<sup>8</sup>

Epstein<sup>9</sup> states that he has observed cases in the Prague Foundling Hospital similar to those described by Winckel. Baginsky<sup>10</sup> says that he has seen a typical example of the disease, but I have not been able to find any further description of it. Sandner<sup>11</sup> gave a careful description of a case seen by him in 1886, and Bar and Grand’homme<sup>12</sup> and Strelitz<sup>13</sup> each reported one seen in the year 1889, and Hirst<sup>14</sup> one in 1890.

**Etiology.**—The cause of the disease is very obscure. No condition of the mother is recorded which could have produced the disease in any of the cases. The only possible, though altogether improbable, exception is in the

<sup>1</sup> Wien. Med. Presse, April 30, 1871, 457.

<sup>2</sup> Congrès pour l'Avancement des Sciences, 2e Session, Lyon, 1873, 877.

<sup>3</sup> Thèse de Paris; Rev. des Sciences Méd., 1874, 229.

<sup>4</sup> Arch. de Physiologie, September, 1873, v. 512.

<sup>5</sup> Boston Medical and Surgical Journal, March 11, 1875, 277.

<sup>6</sup> Oesterreich. Jahrbuch f. Pädiatrik, 1877, viii. 139.

<sup>7</sup> Deutsche Med. Wochenschr., 1879, 303, 319, 415, 431, 445.

<sup>8</sup> Ibid., 1879, 463.

<sup>9</sup> Prager Med. Wochenschr., 1879, 343.

<sup>10</sup> Lehrb. f. Kinderkr., 1887, 54.

<sup>11</sup> Münch. Med. Wochenschr., June 15, 1886, 413.

<sup>12</sup> Jour. de Méd. de Paris, June 9, 1889, 361.

<sup>13</sup> Arch. f. Kinderheilk., 1889, xi. 11.

<sup>14</sup> Univ. Med. Magazine, March, 1890, 285.

two cases of Herz's, in which the fact is to be noticed that both were children of the same parents.

Only one of Winckel's twenty-four cases was born with instruments; eighteen of the cases were fed only on the breast-milk; the possibility of poisoning having taken place was excluded by the careful chemical examination of the organs; and the children were not in any way exposed to cold. The same total absence of discoverable cause existed in the cases of Laroyenne and Charrin's. The influence of extremes of cold and heat in producing hæmoglobinuria has been shown by Ponfick,<sup>1</sup> and two of the cases reported illustrate a possible connection between these factors and the disease,—the patient of Strelitz's, namely, had the operation of ritual circumcision performed in a quite cold room, and Hirst's case had suffered several burns on the legs and buttocks from the too close application of hot-water cans shortly after birth. There is reason to believe, however, that in both instances other causes were more probably active.

The disease attacks the vigorous as readily as the feeble child. In Polack's rather doubtful cases severe intestinal catarrh preceded the discharge of bloody urine. In very few instances could the existence of any focus be discovered from which the absorption of septic matter could have taken place. The wound on the penis of Strelitz's case was perfectly free from pus. In nine of Bigelow's patients there was a diphtheritic inflammation of the mucous surfaces, which developed, as a rule, on the same day with the discoloration of the skin, and can hardly be said to have clearly stood in any causal relation to the cyanotic disease. The same statement applies to the appearance, in Parrot's cases, of "*muguel*" on the buccal mucous membrane some days after the symptoms of the disease had appeared. There is no record of the existence of any septic process in the umbilical wound in any instance, unless it be in one of the cases of Bigelow's, and there is no evidence that this antedated the appearance of the characteristic symptoms. In both of Herz's cases, however, a diphtheritic deposit appeared on the palate some days before the constitutional symptoms developed.

**Symptoms.**—The disease begins in most cases with a very marked degree of restlessness, a refusal of the child to nurse, and a wide-spread cyanotic discoloration of the skin, combined with a more or less icteric hue. In other cases apathy replaces the restlessness, and in some instances convulsions are among the earliest symptoms. The skin is usually cool, but may be hot; the pulse and respiration are often accelerated. Urine of a dark and often coffee color is voided, and makes a brown or greenish stain on the diapers. As the disease advances, the discoloration of the skin becomes extreme, convulsive movements of some sort are liable to appear, and the child dies in a few hours or days with convulsions and in collapse.

The age at which the symptoms first appear is subject to some variation. Bigelow gives the average age at about eight days. Winckel says the dis-

---

<sup>1</sup> Verhandl. d. Congr. f. innere Med., 1883.

ease develops at about the fourth day of life, though in one of his cases it began on the first day, and in one on the twelfth. Pollack states that all of his twelve cases developed within the first six weeks of life. The symptoms in Strelitz's patient did not show themselves until the ninth or tenth day, and the discoloration of the skin in one of Herz's cases not until the eleventh day and in one of Parrot's cases not until the twelfth day.

Looking at the symptoms more in detail, the peculiar tint of the skin is very striking, that of the visible mucous membranes being somewhat of the same sort. It has been variously described as violet (Laroyenne), olive-green or like the color of a bruise (Pollack), color of old copper or olive-bronze (Bar and Grand'homme), bluish (Winckel), brownish black (Sandner), bronze or a mixture of yellow and violet (Parrot), brownish green (Hirst), etc. These differences clearly depend upon the varying proportions of cyanosis and of icterus present. The cyanosis is probably nearly always the predominant feature.

Equally important with the discoloration of the skin is the altered condition of the urine. Its color varies from pale brown to that of coffee-grounds. This alteration was clearly shown in the cases of Winckel's, Hirst's, and Epstein's to be due not to the actual presence of blood in the urine, but to its liberated coloring-matter, either as hæmoglobin or some modification of it, since no or but few red blood-cells were found. In Parrot's cases it would seem that there had been some degree, at least, of hæmaturia, and the same remark applies to the cases of Pollack's. Hæmaturia is ascribed to Bigelow's and Herz's cases, while Sandner describes the urine in his case as that of hæmoglobinuria, though no microscopical or chemical examination was reported in any of them. Strelitz speaks of the violet-brown stain made by the urine on the diapers, and Bar and Grand'homme of the dark-brown coloration produced in the same way, but in neither case was an examination of the urine made. Winckel reports some albumen, renal epithelium, and brownish granular casts. Pollack found a small amount of albumen, renal epithelium, blood-cells, and casts filled with blood-cells. Epstein reports much albumen, and epithelium and epithelial casts containing hæmatoidin crystals. Both Winckel and Epstein observed the presence of micrococci in the urine. The urine in Hirst's case contained albumen and some shells of corpuseles. Parrot found brownish granules and the débris of corpuseles. No bile was present in the urine in the cases of Winckel's, and no other observer refers to this matter. The urine in Herz's and Winckel's cases was voided frequently, and in the latter instance in small quantities and with straining efforts. In one of Parrot's cases but small amounts of urine are said to have been passed.

The nervous symptoms of the disease are of interest. Very frequently among the early symptoms is a peculiar irritability and restlessness. Pollack calls attention to this, and it was noticed also in the cases of Winckel's, Strelitz's, and Bar and Grand'homme's. Convulsions of an epileptoid nature occurred frequently in one of Parrot's cases during eleven days before the

affection of the skin and of the urine appeared on the twelfth day of life. These were probably entirely independent of it. Convulsive movements are very commonly present in the course of the disease, as seen in the extremities, as twitchings and trembling of the eye-muscles, rolling of the eyes, strabismus, and finally as general convulsions (Winckel). Strelitz reports the presence of trismus in his patient. Sandner observed apathy at the beginning of the disease, changing later into somnolence. Winckel refers to the evident somnolence and stupid condition seen in several cases. Parrot's first case, too, went into a comatose condition as the characteristic symptoms of the disease developed, as did one of Herz's patients. Sighing and moaning have been noticed in several instances (Laroyenne, Bigelow, Winckel), and Strelitz's patient occasionally uttered loud cries. Both of Herz's patients passed into a state of collapse with the sudden onset of the disease. Nervous symptoms may, however, be absent or slight. Bigelow makes no mention of any, and Laroyenne and Charrin saw no cerebral phenomena in any case.

The temperature varies in different cases, though it would appear to be usually normal or subnormal. Winckel uses the word "*afebrilis*" in his definition of the disease. Epstein, on the other hand, states that in diseases of the newly-born frequent and great variations in temperature are apt to take place. Consequently the presence of fever may be easily overlooked in this disease unless records are taken at short intervals. In one patient of Winckel's the temperature reached 100.5° F., but in all the others it ranged from 97.5° to 99.2° in the rectum. In one of Parrot's cases the temperature reached 102° F., but fell to 93.2° some hours before death; while in the other case the temperature was usually about normal, rising only once to 100.4°. In one of Herz's cases there was decided lowering of the temperature; in the other it equalled 104.9° F. at first, but was much depressed later. The temperature of Hirst's patient was normal until the day before death, when it reached 102° F.; and that of Strelitz's patient equalled 101.2° on the day before death. Other reporters of cases make no definite statements regarding the degree of temperature, excepting that Laroyenne states it to be lowered several degrees in the last hours of life. It would thus appear that there is a tendency in infectious hæmoglobinæmia to a depression of temperature, but that some elevation of it may be present without militating against the diagnosis, as would be the case did Winckel's statement hold good.

Regarding the symptoms appertaining to the digestive apparatus, one of the most prominent is probably the partial or total indisposition or inability to nurse which developed early in a large number of cases, as in those of Bar and Grand'homme's, Pollack's, Hirst's, and some of Bigelow's. In the patient of Sandner's and in those of Herz's swallowing is described as difficult or impossible. An ulceration of a diphtheritic nature appeared on the hard palate of both of Herz's cases soon after birth, and a diphtheritic inflammation of the mouth was present in nearly all of Bigelow's

patients. In both of Parrot's cases an affection of the oral mucous membrane was present which is described as thrush ("*muguet buccal*"), but the exact nature of which remains a matter of doubt. Thrush is mentioned in three of Winckel's patients. Repeated vomiting was noticed in the patient of Bar and Grand'homme's and in a number of Winckel's cases.

The fecal passages are usually altered in color and incline towards diarrhoea. Bigelow draws especial attention to this point, having found dark-greenish and offensive stools in eight of his ten cases. Faeces of this same dark-green color, sometimes accompanied by mucus, were noticed by Laroyenne and Charrin, Parrot, Herz, and Strelitz. Winckel describes the passages as ochre-yellow or brownish, and seldom diarrhoeic. The diarrhoea preceding the development of the symptoms in the cases reported by Pollack can scarcely be regarded as a symptom of infectious hæmoglobinaemia.

The respiration varies in different cases. It has been described as accelerated by Strelitz, Sandner, and Herz; and decided dyspnoea was observed by Winckel in a number of instances, as well as by Parrot in both of his patients. On the other hand, Bar and Grand'homme describe the respiration as not increased in frequency, and in one of Bigelow's patients it was even slower than normal.

The pulse is, as a rule, little, if at all, altered. This was the case in the patients of Sandner's, Bar and Grand'homme's, and Winckel's. Laroyenne, on the other hand, describes it as rapid in his cases, and Herz found it small and impossible to count in one of his. Parrot, too, could not count it in the early stages of the disease in one instance.

The condition of the blood is a matter of great interest. Laroyenne says that it is brownish black when drawn from the finger, with the number of leucocytes and the volume of the red cells increased, and "granulations" present. Parrot found the number of erythrocytes in one of his cases equaling 1,700,000, with a ratio to the leucocytes of 48:1. In the other the number of erythrocytes was only 1,140,000. In the second case the blood as drawn from the finger was clear. In the first, however, it was very dark, and like pitch. The leucocytes were larger than normal, and very many of the red cells greatly altered in shape; some being of great size, some having a sort of nucleus, or being flattened or lengthened, or shrivelled and small and containing a small or large number of granules. Similar granules were found free in the plasma, either isolated or in groups. In one of the veins of the kidney Bigelow found the ratio of white to red cells equaling 1:20. Winckel describes the blood as syrupy, dark brown or grayish brown in color, and containing a decidedly increased number of white blood-cells of a larger size than normal, and numerous granules. Strelitz examined the blood from the heart of his patient twelve hours after death, and found it brown-red and with almost no normal red cells. Those still containing hæmoglobin were irregularly shaped, or only in the form of fragments of corpuscles, or apparently grouped in masses. Most noticeable

was the very large number of "shadows,"—the corpuscles which had lost their hæmoglobin. Cultures made from the blood revealed the presence of a coccus. Birch-Hirschfeld found cocci in the blood of one of Winkel's cases. The number of red blood-cells in Hirst's patient was reduced rapidly from 5,700,000 to 3,400,000, or 61 per cent., while the hæmoglobin equalled 89 per cent.,—a noteworthy fact, which appeared to indicate the presence of free hæmoglobin in the circulation. The ratio of white to red cells equalled 1:13.5. Poikilocytosis was very marked. Culture experiments made with the blood of this patient taken before death revealed a coccus, the exact nature of which is not yet determined.

Of symptoms only exceptionally observed may be mentioned enlargement of the liver and spleen (Herz); numerous metastatic abscesses, with diphtheritic inflammation of the vulva (Bigelow); inflammation of the eyes (Bigelow); opacity of the cornea (Parrot); erysipelas of the scalp (Parrot); tenderness in the renal region (Pollack); alteration of the size of the pupils (Parrot, Sandner); bronchial râles, irregular respiration, continuous flow of saliva (Winkel).

**Pathological Anatomy.**—The color of the skin and mucous membranes persists after death, though sometimes it is not so intense, and the internal organs exhibit more or less of an icteric color. The chief interest centres on the condition of the urinary organs. Winkel, who has made a much larger number of autopsies than any other one observer, describes the kidneys as not enlarged; and no contradictory statements are made excepting by Pollack, who considers them larger than normal. The color of the organ is variously stated. Pollack described the cortical substance as dark brown, while in the pyramids could be seen dark lines, which he considered to be clots, the extension of large thrombi present in the renal vein. That these lines were true thrombi is not certain. Similar black lines have been remarked by Parrot, Sandner, Hirst, Bar and Grand'homme, and Winkel. Strelitz considered it a very characteristic feature, and depicts it in a lithographic plate. Laroyenne describes the kidneys as chestnut-colored; Hirst as cyanosed, and the cortical and medullary layers well separated. Strelitz says they are dark brownish red, and that the two portions are not well distinguishable. Herz describes the cortex as pale, Sandner as dark red, and Winkel as widened and of a brown color. Parrot calls the kidneys pale cinnamon, with rose-colored spots and evidences of foci of softening; the pyramids being brownish red and exhibiting the dark lines referred to. It is evident that the only characteristic pathological appearance in the kidney, discoverable by the naked eye, consists in the presence of these dark lines.

Echymoses are often present under the capsule or in the cortex (Herz, Winkel, Sandner). Coagula or black or dark-green masses of considerable size are often found in the calices, pelvis, and in the bladder (Parrot, Bigelow, Laroyenne, Herz, Sandner, Bar and Grand'homme). The description of the microscopical appearance of these masses in the different cases

is approximately identical with that given by the different writers of the substance found within the tubules of the kidney. A further account of them will therefore not be necessary.

A microscopical examination of the kidney reveals the presence of masses of a yellow or a nearly black color filling many of the ducts of Bellini and the blood-vessels, as well as the convoluted tubules in some cases, but seldom involving the capsules. Parrot described these masses as without doubt made of corpuscles, although he admits that in many tubules not the slightest form could be discovered which resembled a corpuscle. In some of the tubules, however, he detected genuine blood-casts, while the veins in the kidney could be seen distended with corpuscles. Bigelow describes the substance in the convoluted tubules and the ducts of Bellini as a gray or brown granular mass with no trace of blood-disks, and containing granules of hæmatin. Herz speaks of coagulated blood in the tubules, but gives no details of any microscopical examination of it. Bar and Grand'homme state that the convoluted and the straight tubules are filled with a finely granular exudate containing some deformed red globules. Epstein describes hæmatoidin infarcts in the kidney, and Winckel, Strelitz, Sandner, and Hirst agree that the granular matter is partly or chiefly made up of hæmoglobin, containing few or no blood-cells. I have treated sections of the kidney from Hirst's case with potassium ferrocyanide and hydrochloric acid, in the manner employed by Hunter for the recognition of iron in pernicious anæmia. Thus prepared, the cortex exhibited numerous brightly-colored tubules, the result of the formation of Prussian blue out of the altered blood-pigment present. The glomeruli remained unstained. As hæmoglobin will not respond to this test for iron, it would seem that it must have undergone some further change into an altered blood-pigment. The condition of the renal epithelium varies in different cases, sometimes being entirely unaffected (Pollack), oftener exhibiting some cloudy swelling and perhaps extensive desquamation (Herz, Strelitz, Hirst, Sandner) or fatty infiltration (Winckel). Micro-organisms were present in the kidney in some cases (Bigelow, Winckel, Strelitz, Hirst, Bar and Grand'homme), sometimes within the tubules, sometimes in the blood-vessels, sometimes scattered throughout the substance of the organ.

Parrot describes the liver as of normal color and size, and Laroyenne states that it was of a brown color and on section did not redden; but he makes no further observation regarding it. Bigelow found it normal in all except one instance, and in this there were alterations resembling those of yellow atrophy. Other observers who refer to its condition, though mentioning no special alteration in size, and though attributing different colors to it, uniformly describe a microscopic alteration of the parenchyma, consisting of cloudy swelling or fatty degeneration of varying intensity. This was noted by Herz, Winckel, Sandner, Strelitz, and Hirst. Small ecchymoses under its capsule are described by Winckel. Sections of the liver, which I had prepared from Hirst's case, showed very decided changes in



the parenchyma, the cells being very decidedly granular and indistinct, and the nuclei for the most part invisible. Treated with ferrocyanide of potash, the liver exhibited a decided increase in the amount of iron, but not by any means so great as in pernicious anæmia, nor was the pigment distributed with the same regularity.

The spleen is reported as enlarged,—often very greatly so,—and as dark or almost black, by nearly all writers. Only Bar and Grand'homme speak of it as of normal size, though noticing the black color. It is also said to be congested (Hirst), to contain pigment-granules (Hirst, Strelitz), to be filled with red blood-cells (Sandner), and to exhibit hemorrhages (Herz). Numerous small groups of cocci were found in it by Hirst.

The lungs are described as black by Laroyenne, and as black-red and œdematous by Sandner. In both of Parrot's cases they exhibited points of hepatization, and in Hirst's patient numerous infarcts. Ecchymoses are not uncommon on the pleura (Strelitz, Herz, Winckel). Herz describes the mucous membranes of the respiratory passages as reddened. A diphtheritic deposit was found in the larynx in some of Bigelow's cases, and enlargement of the bronchial glands by Winckel.

Winckel says that the heart-muscle was fatty in most of his cases, and Hirst has confirmed this observation in his patient. Laroyenne and Sandner found respectively a chocolate-colored and a dark-red fluid in the pericardial sac, while Herz describes it as icteric in his case. Winckel refers to the presence of ecchymoses on the pericardium and sometimes on the endocardium.

As regards the digestive apparatus, Bigelow found a diphtheritic deposit in the œsophagus in one instance. Swelling, injection, and ecchymoses of the mucous membrane of the stomach and intestines are described by Winckel, and Sandner also refers to the ecchymoses in the gastric mucous membrane and the presence of a few small black coagula in the cavity of the stomach. Winckel found the mesenteric and inguinal glands enlarged, and patches of ecchymoses on the peritoneum.

Among other post-mortem lesions noticed may be mentioned foci of softening in the brain, apparently independent of the hæmoglobinæmia (Parrot), a chocolate-colored cerebro-spinal fluid (Laroyenne), and minute ecchymoses on the meninges of the brain (Winckel). Obstruction of the renal veins by clots is described by Pollack and Parrot, and thrombophlebitis of the umbilical vessels in one instance by Bigelow. The latter also noticed diphtheritic membrane on the vulva in one case.

**Pathology.**—In the absence of a fuller knowledge of the etiology of the disease, no positive conclusions can be drawn regarding its pathology. Pollack claimed that as the result of an exhausting diarrhœa thrombosis occurred in the renal vein, and that this was the immediate cause of what he designated hæmaturia. Parrot, however, showed that the lesions and symptoms were essentially different, since no blood was present within the tubules after thrombosis, and discoloration of the skin never, in his experi-

ence, accompanied it. The possibility also exists of exposure to cold being the cause of hæmoglobinuria in Strelitz's case; and the occurrence of burns in that of Hirst's. But the similarity of the symptoms and post-mortem lesions in all the different cases points to a more generally acting etiological factor.

One of the most impressive features regarding the pathology of the disease is the fact that in the great majority of cases it has occurred endemically. This was true in the fourteen cases reported by Laroyenne and Charrin, the ten of Bigelow's, and the twenty-four of Winckel's. Facts such as this render it almost certain that the malady is of an infectious nature. The development of diphtheritic processes in the cases of Herz's and of Bigelow's, and possibly also in those of Parrot's, is an additional proof of this. The nature of this infection and the manner in which the child acquires it are still matters fully unsolved. In no instance has the mother of the affected children suffered from any septic puerperal processes.

In almost every instance, too, no wound could be found on the child which exhibited any unhealthy condition. It is to be remembered, however, that every child during the first few days of life possesses an open wound,—the umbilicus,—through which infection may be acquired, and it may be that this can happen even when the wound shows no abnormal appearance. In the absence of infection by this channel, the possibility of this taking place by way of the digestive tract must be taken into consideration. This is the explanation adopted by Winckel for the origin of the disease in his patients, and it would seem that Pollack's cases may be explained in the same way.

Finally, the infectious nature of the disease in question is sustained by the discovery by several observers of micro-organisms in various parts of the body. These microbes are certainly cocci,—except in the case of Bar and Grand'homme's, in which bacilli were also found,—but whether pathogenic or some septic form is not yet known. Strelitz, who has made very careful bacteriological studies in his case, comes to the conclusion that the microbes found by him are to be placed in the group with the streptococcus pyogenes. Smith, in studying Hirst's case, concludes that the organism is the streptococcus pyogenes, while Hatch, in the same case, expresses the belief that, though very similar, it is not identical with it.

Assuming that the disease is infectious, we can readily understand its true nature,—viz., a rapid destruction of the red blood-cells within the vessels, due to the presence of the toxic agent, and producing hæmoglobinæmia, and the consequent hæmoglobinuria, cyanosis, icterus, and ecchymoses. That we have indeed to do with hæmoglobinæmia was evident in the cases of Winckel's, Epstein's, and Hirst's, and Strelitz and Sandner also attribute the symptoms to hæmoglobinæmia; and, though Bigelow and Bar and Grand'homme speak of hæmaturia, yet their descriptions of the renal changes show the truly hæmoglobinæmic nature of the affection. Herz mentions hæmaturia, but his observations are not at all complete. The

cases of Pollack's and Parrot's undoubtedly exhibited blood-cells in the urine and kidneys, and probably in considerable quantity. The blood, however, was certainly in a greatly altered condition, and it is exceedingly probable that the abnormal color of the urine was due in great part to the excretion of the altered coloring-matter of the corpuscles. It is possible that the poison acted also upon the walls of the blood-vessels or upon the red blood-cells in such a way that the latter were able to pass out of the renal capillaries in some numbers, while at the same time the majority were destroyed in the circulation and their coloring-matter excreted in the urine.

**Diagnosis.**—The question has been raised whether infectious hæmoglobinæmia is not identical with acute fatty degeneration of the new-born, described by Buhl in 1861; and the diseases do, in fact, present many points of similarity. In Buhl's disease, however, the infants are usually born in an asphyxiated condition without any adequate discoverable cause for this, and then either die or rapidly develop the symptoms of that disease. Hæmoglobinuria does not occur in it. Hemorrhages from the stomach and bowels and often from the navel, and extensive extravasations of blood into the skin, mucous membranes, and various organs, and the much more chronic course, also serve to distinguish it from infectious hæmoglobinæmia. The autopsy, too, is said to reveal a constant and much more extreme fatty degeneration of the various viscera. One cannot, however, but be impressed with the close resemblance, in many particulars, existing between the two diseases. The reported cases of acute fatty degeneration are too few in number, and the condition too little understood, to determine positively the question of its relation to, or identity with, infectious hæmoglobinæmia.

Infectious hæmoglobinæmia is further to be distinguished from poisoning by potassium chlorate, carbolic acid, and phosphorus. The diagnosis of the affection from poisoning by potassium chlorate must rest very largely on the absence of the possibility of the occurrence of the latter, as the symptoms are very similar. Thus, in poisoning with the chlorate there is cyanosis and often icterus, and the excretion of a dark urine containing hæmoglobin or methæmoglobin and brownish casts exhibiting remnants of red blood-cells. The blood is chocolate-colored and gives the spectrum for methæmoglobin, and many of the corpuscles have lost their coloring-matter. The tubules of the kidneys examined post mortem are found filled with brownish casts, and ecchymoses are frequent in the different mucous membranes. Nevertheless, as distinguishing poisoning with the drug are the greater frequency of dyspnoea, vomiting and diarrhoea, and the presence in many cases of small ecchymoses over the surface of the body; while after death the liver is found enlarged and filled with brown matter, the result of the disintegration of the corpuscles.

Carbolic-acid poisoning may be present in the newly-born, due to the employment of the acid about the mother or the child. It may simulate infectious hæmoglobinæmia to some extent in the dark-colored urine and the cyanosis. The blackish or blackish-green urine, however, is not, as a

rule, due to hæmoglobinuria. When it is treated with nitric acid and then with potash it becomes reddish, then pea-green, and finally violet. Without this peculiar character of the urine the case is not one of carbolic-acid poisoning.<sup>1</sup> Further, dyspnœa is excessive in poisoning by carbolic acid, vomiting and purging are common, and convulsions are exceptional.

Poisoning with phosphorus, which may also in some points bear a close resemblance to infectious hæmoglobinæmia, is scarcely to be expected in children so early in life. Usually one of the first and most constant symptoms is vomiting, and the vomited matter smells strongly of phosphorus and exhibits a phosphorescence in the dark. The stools are light-colored and rarely bloody. Icterus commences only after from thirty-six hours to several days, and is accompanied by dermal hemorrhages, but not by cyanosis. Fever of slight degree is usually present. Enlargement of the liver may often be detected. Hæmoglobinuria rarely if ever occurs, but the urine often contains bile and blood, nearly always sarco-lactic acid, and sometimes sugar, fat, leucin, and tyrosin. At the autopsy the liver is generally found to be greatly enlarged, and to have undergone extensive fatty degeneration resembling the condition of acute yellow atrophy; and there is wide-spread fatty degeneration throughout the tissues of the body. All these symptoms are in sharp contrast with the rarity of vomiting and the absence of enlargement of the liver in infectious hæmoglobinæmia, and the presence of tarry stools, rapidly-developing icterus, cyanosis, and hæmoglobinuria.

A congenital heart-disease, though accompanied by cyanosis, would not exhibit the other symptoms of infectious hæmoglobinæmia.

**Prognosis; Course.**—The prognosis of the disease is exceedingly unfavorable. Only five instances of recovery have been reported, one in the practice of Winckel, two in that of Bigelow, and two in that of Pollack. The duration is somewhat variable, but in all cases short. Pollack's cases died on the second or third day of the disease. The average duration of it in Bigelow's cases was five days, the longest being eleven days, and the shortest sixteen hours. In Winckel's cases the average was thirty-two hours, the shortest time being nine hours and the longest four and a half days. Sandner's patient lived only six hours, Strelitz's two days, Herz's one to two days. Most of Winckel's patients died in convulsions and collapse, and this appears to have been true of most of the cases of other observers.

**Treatment.**—The course of the disease is so rapid and pernicious that efficient treatment is usually out of the question. The chief dependence must be placed on nourishment, tonics, and stimulants. As the child will not nurse, milk must be expressed from the breast and given in small quantities. The patients of Bigelow's who recovered were given tincture of the chloride of iron and wine. Temporary benefit was obtained in Hirst's case by the use of inhalations of oxygen.

---

<sup>1</sup> H. C. Wood, *Therapeutics, its Principles and Practice*, 1888, 603.

# PART III.

## SURGERY.

---

### MINOR SURGERY AND EMERGENCIES IN CHILDREN.

BY CHARLES W. DULLES, M.D.

---

#### MINOR SURGERY.

THE limits of this work make it undesirable to attempt to go in detail over the whole ground of minor surgery in the present article, and it will therefore be restricted to the consideration of the points likely to arise in the practice of every practitioner. These will be discussed in as general a way as possible, leaving to each reader to fill up the outline from his own experience or reading in treatises specially devoted to the subject.

At the risk of repeating what may be said in other parts of this work, a few general remarks in regard to the management of children who require surgical care may not be out of place here. The treatment of patients of this class calls for great skill and judgment in matters which are usually much more simple in the case of adults, and the conditions presented often demand peculiar address in meeting them.

Usually one of the first things to be done when called to attend a child in an emergency is to secure the confidence of its parents or care-takers. This can generally be accomplished by maintaining a thoroughly composed bearing. There must be no evidence of excitement on the part of the surgeon; and, while his mind misses nothing of the gravity of a serious case, his actions must be calm and steady and he must never make too much of trifling injuries. Very often his first investigations will convince him that no great danger threatens; and, as soon as he feels fairly sure of this, he should communicate his opinion to those who anxiously await it. In doing

this it is generally easy to make any reserves which prudence may dictate, without lessening the effect of his comforting assurances.

At the outset it is also necessary sometimes to quiet the commotion caused by an accident and to restrain the zeal of unwise helpers. This calls for a discretion which may be recommended but cannot well be taught. It is much helped by an avoidance by the surgeon of everything like fuss or display and of too great haste to do his work. By-standers whose feelings require that they should do something may be quietly sent to bring towels or water, or given any commission which will occupy them, and those of steadiest nerves can be kept in the room.

Another important first step in the care of children who have met with an accident is to secure their own trust. This is usually not so hard as it sometimes seems. A gentle and composed manner in the surgeon is usually appreciated by even the youngest children, and a few kindly or comforting words will often work wonders with them. Of course there should be no display, before a young patient, of excessive zeal or of surgical instruments. Then there is an art in securing an examination which comes only with practice, and is generally best understood by those who have children of their own. If a child has not been taught to dread "the doctor," it will usually submit to being taken in his arms and soon "make friends" with him.

When this point is reached, the next step is to make a physical examination, in order to ascertain the exact nature of the trouble or injury present. This may be a comparatively easy task or a very hard one. The account gathered beforehand may give the surgeon a good idea of what he will find, or it may leave much to be learned by personal investigation. In any case it is of the utmost importance that the surgeon shall not be led, by the history of the case or by its most striking features, to overlook any condition requiring attention. I happen to know of a case in which an infant was treated almost to its death for an intestinal disorder, without detection of a fracture of the humerus, the pain of which probably caused the fatal result, and of another case in which a fracture of the femur in a very young infant escaped the detection of a physician for several weeks.

It is not always necessary to examine every part and organ of a child's body; but a surgeon should never forget that he may have much more to deal with than what he is asked to treat, and he should never neglect to examine or inquire about the condition of a child's nervous, respiratory, circulatory, and digestive apparatus, or to ascertain if there is present any gross lesion which has not attracted the attention of others. I think it is of importance also to pass in review, at least mentally, the various natural passages or openings on the surface of the body,—the conjunctival surfaces, the nose, the ears, the mouth (with the teeth and tongue), the anus, and the cavities of the genitalia. In regard to these matters less thoroughness is required in some cases and more in others; but the surgeon should never be hasty or careless, and he should always decide for himself what sort of investigation is expedient, and what is not.

After making an examination of his patient, the surgeon determines what is to be done, according to the special conditions present. In some cases operative procedures are required, in others none. In many cases pain demands special consideration. In these I think the surgeon should bear in mind the fact that the relief of pain is of much greater importance to children than it is to adults, and use opium, in some form, without timidity. Six or seven hours of sleep will often transform the appearance of a child who has suffered much pain, and produce a wonderful improvement in its condition.

To produce surgical anæsthesia in children, I think chloroform the best agent, if administered with prudence; although ether is usually a satisfactory agent, while it is regarded as safer than chloroform by many medical men.

In concluding these preliminary remarks, I would call attention to the very great importance of observing—and, if necessary, treating—the general condition of every surgical case as long as it is under the surgeon's care. One who would be a skilful surgeon must be a good general diagnostician and therapist, and he must know when to call the materia medica to the assistance of his surgical armamentarium. This is as true in those conditions which I have been asked to discuss as in the graver ones assigned to other contributors to these volumes.

#### DRESSING-MATERIALS.

It has not been long since articles treating of surgical dressings were filled with descriptions of a large variety of materials and many methods of arranging them; but the practice of surgery in the present day calls for few dressings, and these are applied in very simple ways.

Wounds may be rendered aseptic by washing with boiled water and sometimes by the application of solutions of corrosive sublimate (one to two thousand) or carbolic acid (one to one hundred), after which they may be strewn with powdered iodoform or naphthalin or bismuth, while pulverized white sugar or powdered sulphur may be used for the same purpose. After this they are covered with an aseptic layer of gauze or absorbent cotton or fine jute, over which is placed an impervious layer of rubber tissue or waxed paper, the whole being retained by a suitable bandage.

Such dressings often remain in place until a wound is healed, or until some rare accident demands their removal for inspection of the wound.

*Antiseptic gauze* is composed of cheese-cloth thoroughly boiled and impregnated with corrosive sublimate or iodoform, and can be procured at a very moderate price from any instrument-maker, or can be made without much trouble.

*Lint* is now used chiefly in making wet applications or to hold ointments, when its bulk, softness, and uniform texture are of advantage.

*Absorbent cotton, jute, and fine carded wool* are used to make and maintain uniform and equable pressure: they are usually applied over the dressing of gauze, or over its protecting rubber tissue or waxed paper.

*Bandages* are made of soft muslin or flannel, and, as a rule, they are more comfortable and easier to apply if of cheap and rather open-meshed material.

*Splints* are made of thin metal, very light wood, binder's board, or felt fabric. Many useful splints are obtainable from the instrument-maker; but there are few cases in which a perfectly suitable splint cannot be made out of thin strips of pine wood, or pasteboard obtained from boxes or, if necessary, from large books. The function of splints is often overestimated, and a little ingenuity will usually secure satisfactory means of fixation and support anywhere.

*Adhesive plaster*, as now in use, is made of resin plaster or rubber plaster spread upon strong twilled cotton cloth. The latter is often preferable to the former because it does not require heat for its application; but it is less desirable when the plaster must remain long on the skin, as it is likely to give rise to the formation of an acneform or eczematous eruption. In removing adhesive plaster dressings, it is especially important in the case of children to remember that it is not always necessary to remove all that has been used, and that it may suffice to cut through the strips over or near the wound, leaving the sides undisturbed, and placing any new strips that may be needed over and upon the old ones. Much irritation may be saved a patient in this way. It is also well to remember that when a strap crossing a wound is to be removed, the proper plan is to loosen it from both ends and draw on them towards the wound, and *never away from it*. Another little point of importance is that the removal of an adhesive strip is less painful, as a rule, if it is done quickly and with a steady pull, instead of slowly and by jerks; also, that to pull in the direction of the hairs causes less pain than to pull against it.

#### THE CLEANSING OF WOUNDS.

It is a cardinal point of modern surgery that no wound shall be dressed until it is perfectly clean. This rule may sometimes be relaxed in cases in which nature has already covered a wound with a healthy scab, and sometimes after machinery accidents, when the grime which accompanies them is very tenacious. But in most cases, and especially in the wounds of children, a preliminary cleansing is imperative. This can often be effected by touching or pressing the part with dry absorbent cotton, or cotton which has been moistened and then squeezed nearly dry, or lint, or either of these very slightly moistened; actual lavement is by no means always necessary. When actual washing is required, there should be two vessels, one to contain the water and another to receive it as it flows from the part. The water may be conveyed through a small hose, or may come directly from a spigot, or it may be allowed to fall in a steady stream from a sponge or a mass of cotton, squeezed in the hand, the size of the stream being regulated by the compression, and its force by the height at which the hand is held.



## THE CONTROL OF HEMORRHAGE.

An important part of the preparation of a wound for dressing is the control of hemorrhage,—not the hemorrhage from large vessels, but that from small ones, such as are usually encountered in the surgery of general practitioners and with children.

In almost all bleeding from small vessels, the pressure of a well-applied dressing, especially if elevation be also employed, will do all that is needed in the way of controlling hemorrhage. Such a dressing may be made of dry lint, or lint moistened and squeezed nearly dry, bound on with moderate firmness,—actual tightness is not called for; and often one will have in a little while an imitation of nature's favorite method of healing, by the formation of a scab made up of the dried blood and the tissue of the dressing. The essentials for controlling moderate hemorrhage are dry or nearly dry dressings and moderate compression. Pressure alone is sufficient to control the bleeding from scalp-wounds, which are sometimes spoken of as if they were troublesome to deal with. A compress and bandage will occlude any vessel in the scalp, and almost anywhere else; and, if an unruly patient is likely to pull a bandage off, a pin may be thrust under the vessel and brought out again beyond it, so as to hold it as long as any one could wish. If still greater security be desired, it can be had by adding a "figure-of-eight" to this pin.

## DRESSING OF WOUNDS.

Nature's method of protecting wounds is by the process of scabbing; and when we reflect upon the successful way in which this operates in the lower animals, and often in man too, we may wonder that it should be almost a matter of routine to remove scabs in surgical practice. It may gratify our curiosity, it may even aid our study at times, but it is often of no advantage to the patient, to remove from a disfigured face or a cut head the crusts which are nature's reliable antiseptic dressings. It is often well to leave such crusts undisturbed, and, if they are objectionable in an æsthetic sense, simply to cover them with something better-looking. An artificial scab made with lint, or tarlatan, or thin muslin, and collodion, forms one of the best dressings which have ever been devised for simple incised and not a few lacerated wounds. Many cut heads and simple incised wounds, even after the removal of tumors, go to a prompt and uninterrupted healing under the first dressing of this sort. Efficient scabs may be formed by allowing lint to become saturated with the oozing of a wound exposed to the air. Dry powdered borax, or boric acid, or iodoform, may also be used to promote the formation of a crust. In all these cases, however, it is important to watch lest the crust bind down offensive discharges, as any scab may do: when this happens, the crust must, of course, be removed, and the wound cleaned.

In the case of strumous ulcers and the weak granulations of large burns, the happiest results may sometimes be obtained by setting aside ordinary

dressings, and applying a powder in this way. In these latter cases, exposure of the granulating surface to the air until the serous film covering them has coagulated and formed a species of skin over them is at times of great service.

Lead-water and laudanum is but little better than cold water, so far as my experience would indicate, although it is suited to cases in which there is much heat and pain. This dressing ought never to be covered up, as it very often is, with impervious coverings. Pure laudanum is often a very soothing application.

Dilute alcohol is a refreshing dressing, if it be allowed to evaporate and be removed at the first sign of pain.

The ointments in use in simple surgery are very numerous. The best are fresh cold cream, vaseline, oxide-of-zinc ointment, and equal parts of this and carbolic-acid ointment. The latter are stimulating in their action. A piece of lint or muslin should be spread with the ointment and trimmed down to the exact size of the sore. If spread on the adjacent skin, it will often after a while set up an artificial eczema, very annoying to the patient.

The use of poultices is often overdone. Poultices are of service when it is desired to increase vascular activity in low grades of inflammation, with depressed circulation, and when it is desired to promote or increase pus-formation. But they do their work in a short time, and their prolonged use may bring about a condition in which nature seems unable to get beyond the production of a very feeble and unhealthy sort of tissue. Kept hot and frequently changed, so as to get away filthy discharges or sloughing tissue, for a few days they are invaluable; but allowed to cool, left on long at a time, and continued for many days, they may do great harm. When a slough is to come away, as after cauterization or the opening of a felon or carbuncle, nothing equals poultices for comfort and effectiveness. But, even in these cases, one should give them up as soon as the slough is away, and treat the wound as a simple ulcer.

There are no cases which so much enforce this conviction as those of deep inflammations of the hand and foot,—felons and palmar and plantar abscesses. I have seen many cases which have illustrated the advantages and disadvantages of the use of poultices in the most impressive manner. Hands affected with deep palmar inflammation are sometimes almost sacrificed to the persistent use of the poultice; and they would turn back to recovery if the poultices were laid aside and nature given a chance to do what she could without them. Felons well opened and then too long poulticed may keep unhealed for a long time, the tissues of the finger becoming boggy and of low vitality.

A felon should be opened deeply whenever there is pus actually present,—never before, for then it can be aborted; then bleeding should be encouraged by a good soaking in very hot water; then a poultice should be used for *one day only*, soaking frequently in water as hot as can be borne. After

this the part may be dressed with pure laudanum, or lead-water and laudanum, or a simple ointment, unless there is obviously a slough forming; and the patient may usually be dismissed in a few days. When a felon has gone on to destruction of the vitality of bone or tendon, poultices may be used longer; but one should be always on the lookout for the time when they can be thrown aside.

The best treatment of palmar and plantar abscess, or rather of deep inflammations of the hand and foot, cannot be stated in a few words; but alas for the patient whose doctor is too timid to use the knife and too assured of the saving grace of the poultice! Too little of the one and too much of the other is a sad combination.

The pressure which can be secured with adhesive straps is useful in a number of inflammatory conditions. The application of narrow straps will furnish great relief in the case of boils and carbuncles, and I have had cases of paronychia which resisted assiduous treatment for a long while, but in which immediate relief and rapid recovery followed the application of a circular dressing of adhesive plaster round the end of the finger.

Collodion is another agent which may do good service in minor surgery. Many wounds can be easily and effectively coaptated by drawing the edges together, laying over them a strip of tarlatan or other bandage, and saturating it with collodion. It should be remembered, however, if one is dealing with children, that collodion applied to a raw surface is very painful for a while. In applying dressings to the face a bandage may often be entirely dispensed with by using collodion in this way, or by placing against a small wound or ulcer or fistulous opening a little absorbent cotton and gluing its edges down with the collodion; and a neat, soft, absorbent, but impermeable dressing will be made.

A mistake is sometimes made in bandaging too tightly. There is another error, much commoner, and that is bandaging too heavily. Children sometimes come to dispensaries with a member firmly bound to a splint, with the laudable object of preventing injurious mobility, but loaded down with successive layers of bandage, till the heat has set up an active inflammation, with the customary accompaniments of pain and swelling, which subside when the lightest possible splint is used and the thinnest possible bandage.

Sometimes it is desired to apply water after a bandage has been put on. In such cases, of course, the bandage should be thin and open-meshed, and put on as loosely as is consistent with safety. For this purpose the cheap unbleached muslins are far better than the fine ones furnished by the instrument-makers, and cheese-cloth may be better still. Water can also be insinuated under a bandage, if the member has first been wrapped in a layer of absorbent cotton or lint.

The placing of cotton under a bandage has other important uses than to facilitate the application of water,—*e.g.*, to exert uniform pressure, to prevent swelling, to promote absorption of effusions. One who has not

tried it systematically would hardly believe what this sort of compression will accomplish ; and it might be set down as a rule, that all contusions of joints, and most inflammatory swellings, should be subjected to the equable compression and gentle warmth of dry cotton and a pretty firm bandage. This method is better than the traditional lead-water and laudanum.

An important point in regard to splints, and worthy of particular mention, is their weight. A splint should be no heavier or thicker than is absolutely necessary. The lighter the better, is a good principle. Let light pasteboard be used when possible, or the very thinnest wood. Nor need the weight and thickness be increased by padding. This is especially true in regard to splints for the arm, where wooden splints are oftenest used. In most cases in which splints are used it is sufficient to wrap a thin wooden splint in waxed paper, to make it perfectly smooth and keep it clean, and to interpose between it and the arm a double strip of lint. These may be fastened in place on the arm with three or four strips of adhesive plaster, avoiding the seat of fracture or other injury, and covering all with a light bandage. Then the parts can be examined at any time by simply removing the bandage, without taking off the splint or disturbing the seat of injury. Cotton may be placed where the member does not touch the splint, and bony prominences must not be pressed too hard against it.

The best splint for the forearm and hand is, I think, the posterior straight splint. Any one who studies a forearm will see that when the hand and fingers are extended, the dorsal surface is almost an accurate plane, while the ventral surface is very uneven. A straight splint fits the back of the arm and hand accurately, secures perfect fixation, and permits use of the fingers so as to avoid the risk of stiffening better than any other. The posterior splint has decided advantages in the way of lightness and the facility it affords for examining the seat of injury without disturbing it. The Bond's splint, on the other hand, as frequently applied, is heavy, hot, more or less painful, and troublesome to remove for subsequent examination.

It ought to be an *invariable* custom, with those rare exceptions in which for the purpose of drainage it must be reversed, to have a sling so regulated that it will *support the hand at a higher level than the elbow*. A neglect of this very simple and, I believe, very important rule is sometimes followed by great pain and swelling of the hand and by a degree of discomfort which would be incredible to one who had not investigated the matter. Further, a sling should be broad enough to support more than a narrow strip of the arm, or one will be apt to find its position marked by a furrow dividing two swollen parts of the arm, in a manner which is not neat, and which suggests possible injury or interference with the most rapid recovery. Another point about slings concerns the length of time they should be used. Here our routine is sometimes too rigid. It cannot be stated exactly how long a sling may be useful ; but I have often found it of advantage to let an arm be taken out and allowed to swing at the side, at least occasionally, long before the splint could be dispensed with.

In the treatment of children for minor injuries it is well to bear in mind that their tissues usually heal kindly and promptly, and that there is such a thing as making too much fuss over them and investigating them too frequently. There are probably cases in which a few strips of adhesive plaster and a neat bandage would do better than a formal dressing and a splint. On the other hand, there are some injuries which in children require a splint, although in adults none is needed.

In conclusion, it may be said that in all the minor surgery and treatment of accidents in children the surgeon should aim to exercise keenness without fuss, thoroughness without severity, gentleness without weakness, patience without indifference, and foresight without apprehension. There are no patients who demand more good qualities of head and heart, and none who make better returns for their exercise.

---

## EMERGENCIES.

The accidents and emergencies to which children are liable are different from those of adults, in that there are some to which the former are more exposed than the latter, and some to which children are not liable while adults are. The most usual emergencies in children we will consider, taking those which are more or less surgical in their nature and omitting those which are purely medical.

### OBSTRUCTIONS TO RESPIRATION.

**Drowning.**—In cases of drowning, if natural breathing has ceased, the first thing to be done is to free the body from any clothing which binds the neck, chest, or waist, and to turn it over upon the face for a moment, thrusting a finger into the mouth and sweeping it round, to bring away anything that may have got in or accumulated there. Then the body should be laid out flat on the back, with something a few inches high under the shoulders, so as to cause the neck to be stretched out and the head to be carried well back. The tongue should now be drawn forward out of the mouth and held by an assistant, or, if there be no one to do this, a pencil or small stick may be thrust across the mouth on top of the tongue and back of the last teeth, to keep the mouth open and the tongue out of the throat. A very good way to get the base of the tongue clear of the windpipe is to carry the head well back from the chest and to press the angles of the jaw forward with both thumbs applied just behind the rami of the lower jaw-bone.

To secure artificial respiration the operator should place himself on his knees behind the patient's head, seize both arms near the elbows and sweep them round horizontally, away from the body and over the head, till they meet above it, when a good, strong pull must be made upon them and kept up for one or two seconds. This effects an inspiration. (Fig. 1.) The

second manœuvre consists in returning the arms to the anterior surface of the chest, and making strong pressure against the lower ribs, so as to drive

FIG. 1.



the air out of the chest and effect an act of expiration. This need occupy but a second of time. (Fig. 2.) Another plan is to hook the fingers under the ribs and draw them up firmly, though gently, and then release them.

FIG. 2.

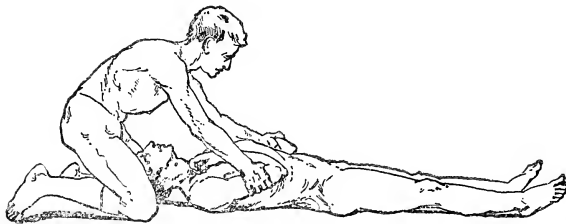

If either of these plans is regularly carried out, it will make about twenty complete acts of respiration in a minute. It should be kept up for a long time, and not abandoned until recovery of natural respiration or until the heart has ceased to beat. The cessation of the pulse at the wrists must not be taken for a sign of death. Often life is present when even an acute ear cannot detect the sound of the heart. Deep pressure with the finger-ends just below the lower end of the sternum may sometimes reveal pulsation in the aorta when it cannot be found anywhere else.

Wet clothing should be removed from a drowned person as soon as possible. This can always be done without interrupting the artificial respiration or exposing the person. Something may be laid over the body and the wet clothes loosened under it and drawn down over the feet. Then the body may be quickly slipped on to something dry, and covered with some other fabric, if the first has become wet, while this, in its turn, is pulled away from underneath.

Warmth is to be secured by any means which ingenuity may suggest,—hot bottles, or plates, or bricks, or stones, or even boards that have lain in

the summer sun. At the sea-shore there is plenty of hot sand, and often plenty of baking bathing-costumes. The body and limbs may be gently, but constantly, rubbed towards the heart, to help the blood in its labored circulation. None of these things need interfere with the efforts to secure respiration, which must be uninterrupted.

Some stimulant is to be given as soon as it can be swallowed. Half-teaspoonful doses of whiskey or brandy, in two teaspoonfuls of hot water, may be given every ten minutes, till an ounce has been taken.

As natural respiration begins to be attempted, it should be aided as much as possible by timing the artificial to it. It may be stimulated by carefully applying smelling-salts, or hartshorn, to the nose, by slapping the skin lightly but smartly, or by dashing hot water upon the chest. Where it is available, there is no stimulus to respiration better than that of a good faradic battery used so as to cause a reflex sobbing, or deep breathing, by the pain it causes. Little by little natural breathing will take the place of the artificial; but it must not be left unwatched for some time.

Nothing but danger from cold, or pressing necessity, should prompt the removal from one place to another of a child who is being resuscitated, before this has been thoroughly accomplished. If removal cannot be avoided, it must be effected with great care. After resuscitation the child should be put in a warm bed, being carried carefully, with the head low, and a watch should be kept to see that the breathing does not suddenly stop.

Where natural breathing has not ceased, all the steps just described should be carried out, with the exception of artificial respiration. But this should be had recourse to upon the first evidence that natural respiration is failing.

**Strangulation by hanging**, or by anything which compresses the trachea from the outside, is to be treated by re-establishing the respiration in the same way as for drowning. The obstruction is, of course, to be removed, and natural respiration stimulated or artificial respiration employed. Hanging is not an unheard-of accident with children, as they may hang themselves accidentally, and a child has been known to hang a younger one in imitation of what it had heard described by its parents.

**Suffocation with noxious gases or vapors** calls for instant removal to the fresh air and for the establishment of natural respiration, or of artificial until the natural is re-established, as described in speaking of drowning.

**In strangulation caused by a foreign body** in the throat, œsophagus, or trachea, it is not always easy to tell which of these passages is clogged, but usually there is an active irritation, with coughing, when a foreign body lodges in the larynx or trachea, while swallowing can be done quite readily. On the other hand, when the œsophagus is stopped it is usually impossible to swallow, and there is little or no tendency to cough, no matter how much the breathing may be interfered with. Foreign bodies in the fauces or larynx are not so hard to discover.

If a foreign body be within reach of the fingers, it may often be easily

removed. If not, a pair of forceps may be used, or, in a pinch, a pair of blunt-pointed scissors. Or a hair-pin may be straightened out and one end bent round so as to make a loop, and this used to dislodge the foreign body; or the handle of one blade of a pair of scissors may be used in the same way. It has been stated that for foreign bodies in the throat, such as pieces of meat, etc., a simple mode of relief is to blow forcibly into the ear. This sometimes excites powerful reflex action, during which the foreign body is expelled. Such a plan is so easy of execution that it is certainly worth trying.

Children not infrequently get buttons, coins, or marbles in their throats. These may often be pulled out or expelled by vomiting induced by titillation of the fauces, or by an ordinary emetic or a hypodermic injection of one-sixth of a grain of apomorphine. Holding the body up by the legs, with the head hanging down, may sometimes aid other efforts to get rid of such things. Attempts to push the foreign body down may prove successful.

If foreign bodies get into the larynx or trachea, a moderate blow on the back with the open hand, or a quick strong squeeze of the chest, sometimes aids the coughing act; and inverting the body may assist in dislodging the foreign body if it be not too tightly wedged in. If this does not succeed, they may be removed with forceps, or laryngotomy or tracheotomy may be required.

When coins, marbles, slate-pencils, or nails are swallowed by children, it is usually a mistake to give an emetic or a purgative. The proper plan is to let the bowels alone and to give plenty of good solid food, especially vegetables, so that the foreign body may be surrounded with the waste and carried out of the body without injuring the walls of the intestines.

#### FOREIGN BODIES IN THE EYE, NOSE, AND EAR.

**Foreign Bodies in the Eye.**—Small substances, like cinders, dust, or small chips of stone or metal, can often be removed from the eye by very simple means. Sometimes the flow of tears washes them out. At other times catching the upper lid by the lashes and pulling it away from the eyeball and down over the lower lid, then letting it go so that as it recedes its under surface is swept by the edge of the lower lid, will clear it out. If this does not prove successful, a loop made of a horse-hair or of a long human hair can be passed under the lid and swept from the outer side towards the nose and drawn down. This may serve the purpose. If it does not, the upper and lower lids must be everted and examined with a good light and the aid of a lens if necessary.

The eyeball must also be examined and any foreign substance removed.

One must be on his guard against the sensation which is sometimes left after a foreign body has been removed from the eye. But a most careful search should be made before this is taken to be a self-deception.

After removing a foreign body from the eye, the irritation may be sufficient to demand cool, wet applications, or even anodynes. Nothing is



better than a thin mucilage of pure, clean gum-arabic poured freely in the eye; or a drop of a four-per-cent. solution of cocaine, or of a one-per-cent. solution of atropine, may be applied to the eye. A bandage loosely applied often does much good.

When lime gets in the eye, the eye should be deluged with water, and a little vinegar or lemon-juice and water (a teaspoonful of vinegar or lemon-juice to a teacupful of water) poured over the eyeball.

**Foreign Bodies in the Nose.**—Children sometimes place, or have placed, in their noses small bodies, such as marbles, buttons, peas, beans, or small grains. To get rid of them the nose should be blown hard, or sneezing may be excited by tickling the nose or giving snuff, or the child may be told to take a full breath and then be given a smart blow on the back. Some one of these plans may dislodge the foreign body. If it does not, the affected nostril may be closed while the other is blown into, through a rubber tube, and on suddenly releasing the closure of the side occupied by the foreign body it may be driven out. If none of these methods succeed, instrumental extraction will be required.

**Foreign Bodies in the Ear.**—The removal of foreign bodies from the ear is so delicate an operation that, when possible, a specialist should be asked to do it.

If the body be a metal or mineral one, the ear may be syringed out thoroughly. When instruments are used, it must be remembered that great damage may be done by the least roughness. The use of the forehead mirror is almost always indispensable, and care must be taken not to mistake the glistening of the membrana tympani for a foreign body.

If live insects get into the ear, oil or glycerin or salt-and-water should be poured in. Or a plug of cotton soaked in a strong solution of salt and vinegar may be placed in the ear and the head turned over on that side. A method which has sometimes been successful is to turn the ear to a bright light, so as to tempt the insect to back out.

#### LOSS OF CONSCIOUSNESS, AND CONVULSIONS.

The causes of unconsciousness may be classified as disorders of the circulation, disorders of the brain, poisoning, and intoxication. The latter, of course, is very rare in children.

**Unconsciousness due to disorder of the circulation** is familiarly illustrated in fainting. It is marked by paleness of the face, and usually by coldness of the extremities.

**Unconsciousness due to disorder of the brain** may depend upon disease or injury. Disease of the brain is recognizable from its gradual approach. Injuries of the brain are usually accompanied by external signs, such as dirt, swelling, bruises, or cuts, which show that violence has been inflicted, or they occur under circumstances which make a suspicion of violence reasonable. In apoplexies some of the external evidences might prove misleading, but besides these there are often found an unequal dilata-

tion of the pupils and paralysis on one side of the face and body. In the unconsciousness of epileptic convulsions there are usually frothing, biting of the tongue or lips, and the peculiar cry before unconsciousness sets in.

**Unconsciousness due to poison** may be caused by a poison generated within the body, as in serious kidney-disease. In such cases there are usually convulsions as well as unconsciousness, and often a dropsical appearance about the eyes and legs, very profound stupor, and a smell like that of urine about the person affected.

The cause of poisoning by gases is generally easy to detect. In insensibility due to opium or chloral the pupils are strongly and rigidly contracted, the very opposite of what is seen in drunkenness.

**Unconsciousness due to intoxication** is marked by many signs of other insensibilities, but it has these peculiarities: the face is usually flushed, the body relaxed everywhere, the person capable of being roused by loud cries, the pupils dilated evenly, and a distinct odor of liquor may often be discovered.

In determining the cause of unconsciousness the following plan may be adopted:

1. *Examine the head.* If there is a cut or a bruise, it is to be suspected that there is a brain-injury.

2. *Examine the pupils.* If they are permanently contracted and do not dilate when the eyes are shaded, it is probably a case of brain-disease or opium-poisoning. If one pupil is contracted and the other dilated, it is a case of injury or disease of the brain.

3. *Examine the face.* If it is drawn and wrinkled on one side and smooth on the other, the case is one of apoplexy, or embolism in the brain, or pressure upon some part of the brain.

4. *Examine the mouth.* If it is frothy and if the tongue or the lip is bitten, it is probably a case of epilepsy. Of course it will be borne in mind that the tongue may be bitten accidentally by being caught between the teeth in a fall.

5. *Examine the arms and legs.* If one is rigid and one relaxed, or if one moves when pinched and the other does not, it is hemiplegia or hysterics. If it be the latter, the person affected will usually resist any attempt that may be made to open the eyelids; and when the eyelids are forcibly opened the eyeballs will usually be found persistently rolled up, which may be regarded as an almost infallible evidence of hysterics. At the same time, close watching will generally lead to the discovery of some sign that the affected person is listening to what is being said about him or her.

6. *Examine the temperature of the skin.* If the skin be burning hot and dry, sunstroke or heatstroke may be suspected.

*The treatment* suitable for all cases in which there is doubt as to the cause of unconsciousness is to secure quiet and rest, the body being laid upon the back, with the head a little raised. If there be great paleness and a cold surface, with slow, sighing breathing,—the signs of prostra-

tion,—smelling-salts or hartshorn may be held under the nose, hot tea or coffee given, and heat applied to the body. If there be great heat of the surface, cold may be applied to the body and head, and cold drinks given.

*Fainting.*—A fainting person must be laid out flat at once, so that the heart may not have to work against the force of gravitation in sending blood to the brain. Sprinkling water upon the face and holding smelling-salts to the nose tend to excite the nerves of sensation and rouse the brain and heart to renewed activity. Nothing else is usually necessary; though if a person is very slow in coming to, it may be well to apply heat in the form of a mild mustard plaster or hot moist cloths to the pit of the stomach.

**Hysterics** are best treated by the exercise of calmness and patience, sometimes by taking no notice of the attack, or by leaving the sufferer in a room alone. Heroic measures, like dashing water into the face, are not to be generally recommended. Good is sometimes done by giving valerian or Hoffmann's anodyne.

**Epileptic fits** are to be treated very much like fainting-fits, because in them also the brain is temporarily bloodless. At the same time, any movements calculated to injure the person must be controlled. There is no use in struggling against such as will do no injury; they had better be simply regulated, and no attempt made to prevent them entirely; but a piece of folded cloth or a piece of soft wood may be—if it can be—thrust between the teeth, to prevent the usual biting of the tongue. When the height of the convulsion is passed, rest, quiet, and perhaps a moderate stimulation may be secured. Here again the flat position of the body must be maintained.

**Convulsions** of children and infants are generally (in the absence of brain- or kidney-disease) due to some irritation of the digestive apparatus or to teething. They are usually preceded by some other evidence of irritation, such as restlessness and fretfulness. The spasms may affect the whole body at once, or only a half, or only one limb at a time. The eyeballs sometimes roll about or squint, or, they are turned far up, so that only the lower part of them can be seen.

When convulsions occur, the child should have cold applied to the head and heat to the body. It often seems to do good to place it in a tub of hot water to which some mustard has been added. A large injection of hot soapsuds should also be given, to clear the bowels out, and, if possible, an emetic, in the hope of removing any cause of trouble from the stomach. Irrigation of the colon with moderately cool water, as taught by Monti, of Vienna, is sometimes of the greatest service in convulsions of children. For the production of vomiting, one-sixth of a grain of apomorphine may be given hypodermically. In some cases of convulsion the administration of chloroform, or an enema containing five grains each of chloral and bromide of potassium or of sodium, will bring the spasms to an end.

**Apoplexy.**—For this condition, which is very rare but not unknown in children, rest and cold to the head constitute the best treatment. The

bowels should be emptied, if possible, with an injection of hot soapsuds, and a purgative given by the mouth as soon as it can be swallowed.

#### INJURIES TO THE BRAIN.

**Concussion of the brain** may be caused by blows or falls on the head, or even by falls upon the feet or the buttocks. In such cases there is sickness, sometimes fainting, with paleness and depression. There is also usually confusion of ideas, and the sufferer cannot talk continuously and coherently. There may even be unconsciousness.

The proper treatment for this condition is rest in bed, quiet, and plenty of fresh air. If the skin becomes cold and clammy, heat should be applied to the body and limbs. No whiskey or brandy should be given.

**Compression of the brain** is marked by loss of consciousness, sometimes paralysis, sometimes twitching of the muscles, or even convulsions, and usually heavy snoring breathing, with wide dilatation of one or both pupils. The treatment is the same as for apoplexy.

#### EFFECTS OF HEAT.

**Burns or scalds** are usually dangerous in proportion to their extent and depth. Those which involve as much as half the surface of the skin are almost necessarily fatal.

After an extensive burn or scald, so much of the clothing as has to be removed must be clipped away, so as not to burst blisters that have formed. These may be punctured at one edge and their contents allowed to run out, and the elevated cuticle to fall down upon the deeper layer. Then a dressing of pure sweet oil, castor oil, or vaseline is to be applied on strips of soft old linen, and disturbed as little as possible afterwards. Iodoform is a very soothing application to burns, either in powder or in an ointment; although its prolonged use has a tendency to promote or prolong suppuration. Carron oil is also an excellent application, and stimulants or anodynes may be given as required. In case of a severe and extensive burn, the entire body may be immersed in a bath, to be kept at a temperature of 100° F.

Slight burns or scalds are best treated by applying a cloth soaked in a strong solution of baking-soda—the bicarbonate—in the proportion of a heaping tablespoonful in a teacupful of water, or it may be powdered on without using any water. Carron oil is a good application for such burns. So is the white of egg. In an emergency damp earth may be used, or white-lead paint. Anything may be used which will prevent friction and exclude the air; but nothing should be used which will stick in cakes and prevent after-examination or make this very painful. For this reason flour and cotton batting, though often recommended, had better not be used. For small burns, simple cool water is better in every way than these. Indeed, for any but the most extensive burns it is one of the best remedies: an arm or a leg can be immersed in it and left there a long while with great advantage.

**Burns with acids** must be deluged with water and then treated like other burns.

**Burns with caustic alkalies**, such as soap-lye, should be treated with an application of vinegar, followed by applications of oil.

**Burns with hot pitch.**—After such burns the pitch often sticks. In such a case it ought not to be removed immediately unless in excessive amount.

**Sunburn**, and the burns caused by external applications, like mustard, may be treated very successfully with bicarbonate of sodium. This may also be mixed in equal parts with vaseline, cosmoline, or lard from which the salt has been boiled out, and used as an ointment.

**Sunstroke**, or more properly **heatstroke**, is not usually due to the direct rays of the sun, but rather to a prolonged elevation of the bodily temperature, especially in confined places. When it takes place in the open air it is apt to be on oppressive, heavy, or murky days. It is generally preceded for some time by pain in the head and a sense of oppression. The attack, however, culminates in loss of consciousness, with heavy, labored breathing, and an intense burning, dry heat of the skin, while the bladder and bowels are often involuntarily evacuated. The absence of perspiration in the presence of so great heat is one of the most characteristic symptoms of heatstroke.

The treatment consists in first lowering the temperature. As much of the clothing as practicable must be removed, and the patient should be transported to a cool and airy place if possible. Cold must then be applied to the head and body, and ice may be rubbed over the chest and placed in the armpits. Pouring or dashing cold water over the body is not to be advised, as it conveys a needless shock to the system; but there is nothing better than to place the body in a cold bath, or to wrap it in sheets kept wet and cold by renewed applications of cold water or ice. The temperature of the body must be watched, as there is some risk of pushing its reduction too far. When the temperature has been brought down to 100° F. or consciousness has returned, the cold may be discontinued, to be renewed only if the surface becomes again very hot.

**Heat-Exhaustion.**—This is a condition of great depression of the system due to the action of heat, and, occurring in hot weather, it might be confounded with sunstroke or heatstroke. But in heat-exhaustion, instead of a hot, dry skin, there is a cold, moist one. This calls for rest, fresh air, and a cool apartment, but for no application of cold to the surface. Small doses of brandy or whiskey thoroughly diluted may be given, and the system gradually brought back from its depression.

**Lightning-Stroke.**—This is marked by evidences of shock, with reduction of the force of the circulation, weak pulse, and slow, sighing breathing. It is to be treated with rest and stimulants, and warmth applied to the body.

## EFFECTS OF COLD.

Freezing is best treated by gradually bringing the temperature up to that which is normal and maintaining it there. When fingers or toes are frozen or frosted, warm baths and gentle friction are to be used, afterwards covering with a thick, hot poultice. In such cases gangrene not infrequently follows the freezing. Frozen ears or noses are of less frequent occurrence, but must be treated on the same principles.

If the whole body has been exposed to extreme cold, there will follow a depression which requires the most cautious treatment. To restore its warmth is the first demand, and for this a warm bath, made gradually warmer until as hot as can be well borne, surrounding with heated blankets, or exposure before an open fire, may be used.<sup>1</sup> At the same time, stimulants may be given internally, such as hot tea or coffee, with the addition of small quantities of spirits.

## SPRAINS.

Sprains of the fingers or of the wrist require cold and moist applications. In the latter the hand and forearm should be covered with cotton, bandaged smoothly, and laid on a straight splint and lightly secured to it with a soft bandage or broad strips of sticking-plaster. One of these should go round the hand and one or two round the forearm above the wrist,—not over it. Sprains must be treated by rest, and by heat or cold, whichever gives the most comfort.

Sprains of the ankle are not infrequently complicated with a fracture of one of the malleoli. This complication may give rise to much trouble, and requires very skilful and patient treatment. The general principle in the case of a sprained ankle is, first, to put the joint at complete rest, to allay inflammation if it arises, and afterwards to promote the absorption of inflammatory products. The foot and ankle should be covered with cotton or carded wool and a bandage carefully and smoothly applied. The use of a splint may usually be dispensed with, if the bandaging is well done. In some cases, however, a splint such as is used after tenotomy for club-foot is of great service. The dressings may remain undisturbed for days if the ankle is comfortable. If the dressings become loose from rapid diminution of the swelling, they should be removed and reapplied. When this is done, careful massage or douching with alternate streams of hot and cold water may be useful.

After the inflammatory stages—if they have not been averted—any deposits may be removed by massage, douching, and careful passive motion.

---

<sup>1</sup> This recommendation is contrary to popular belief, and contrary to what is taught in most text-books, as well as in books on the treatment of emergencies. But it has been proved to be correct by experiments made in Russia, where it was found that the best way to resuscitate dogs which had been frozen was to put them at once into a hot bath. Of twenty animals treated by the "gradual" method in a cold room, fourteen died; of twenty introduced at once into a warm room, eight died; of twenty placed immediately in a hot bath, *all recovered*.

## WOUNDS.

Wounds may be classified as contusions, contused, lacerated, punctured, poisoned, incised, and gunshot wounds.

**Contusions** are best treated at first, when painful, by the application of cold wet cloths. Pure laudanum is often a very acceptable application. Later, when the pain has subsided, hot wet cloths are best, as they favor the carrying off of the blood that has escaped.

In contusions of the chest or abdomen internal organs may be injured. Evidence of this may be seen in spitting of blood, or vomiting it, or passing it from the bowels or from the bladder; or there may be great depression. In such cases complete rest must be secured, and the strength of the sufferer sustained by means of warmth applied externally and careful stimulation internally, until the nature of the injury is exactly made out and a suitable line of treatment may be adopted.

**Contused Wounds.**—These are cuts or tears accompanied with bruising of the tissues. They are to be treated like lacerated wounds. Unless they bleed freely, warm applications are better suited to such wounds than are cold ones.

**Incised wounds**, if simple and small, call only for a piece of adhesive plaster and perhaps a bandage. If large, the edges should be brought as near together as possible, and supported so by adhesive plaster or by bandages. If an entire part be cut off, as an ear, a nose, a toe, or a finger, it should be cleaned with lukewarm water, and put in its place, with sutures, bandages, and a splint. Some very remarkable cases of reunion of such parts are on record, and an attempt to save them is not to be lightly rejected.

**Lacerated Wounds.**—In lacerated wounds the torn parts can be placed as nearly as possible in their natural position (after removal of any foreign matters that have entered them) and covered with cool wet lint, or with lint soaked in laudanum or in alcohol and water. If the tear has been very great and the sufferer is depressed and cold, teaspoonful doses of brandy or whiskey in hot water may be administered, and lint wrung out of hot water placed over the injured parts.

**Punctured wounds** are made with sharp-pointed objects, like arrows, pins, needles, tacks, fish-hooks, glass, thorns, splinters, or teeth.

If a needle is run into the flesh, the surgeon should make sure whether any of it is still in the tissues or not before making an incision. In most cases this is not hard to do, but sometimes it is impossible.

Fish-hooks may be removed by a simple incision, or the string may be cut and the point of the hook pushed through the skin and the whole drawn out, as a needle would be in sewing. If it can be done, the broad part of the hook may be cut off before trying this. But this is usually not easy for the operator or the patient.

Splinters are dangerous in proportion to their size and according to the

part they enter. Small splinters may be picked out with a needle. Splinters under the nails may be removed by scraping the nail as thin as possible over the splinter, then splitting it or cutting a little tongue out.

Splinters of glass must be removed by incision, and the wound treated on general principles.

Splinters in the eye should be removed with the greatest care, and, if possible, by a specialist. Afterwards the eyelid should be gently closed, both eyes covered with a layer of absorbent cotton soaked in cool water, and a bandage placed round the head, so as to keep the lids as still as possible. This bandage should not be too thick nor put on too tight, and the application should be kept cool, with ice, if need be.

**Poisoned wounds** are usually punctured, and result from the bites or stings of animals or insects.

The bites of venomous serpents usually demand the prompt removal of the part bitten. It may be cut out instantly. Before this the part should be encircled above the wound with a tight ligature, and, if small enough, thrust into the mouth and sucked hard, so as to extract the poison. Cauterization may be effected with anything at hand, like a knitting-needle or a nail, heated to redness. Stimulants may be administered if necessary.

The stings of tarantulas, scorpions, centipedes, etc., are to be treated with cold, and hartshorn applied to the point where the sting entered.

The stings of insects may be treated with cold wet alkaline applications: wet earth is a very good one. The application of a drop of hartshorn or some wet salt often gives great relief.

The bites of cats and rats are sometimes followed by severe inflammation. The treatment consists in cleansing the bites, and treating them as lacerated wounds.

**The Bites of Dogs.**—If any one be bitten by a dog in good health, only the simplest treatment will be necessary. If the dog be sick, local inflammation or severe constitutional disturbance may follow. In case of reasonable suspicion, the wound may be thoroughly cleansed and an application of hartshorn made to it, in addition to energetic sucking to extract any irritating material which may have entered it. A prolonged study and considerable experience with regard to the subject have convinced me that the general practice of cauterizing dog-bites with nitrate of silver is dangerous and should be abandoned.

Most medical men know that it is a foolish thing to kill a dog that has bitten anybody, soon after this has taken place. Such a dog should be caught and kept under the observation of a person of great carefulness, intelligence, and special information. The too speedy slaughter of a dog has robbed many a sufferer of the assurance that would have been gained by seeing it living and well, and has sent many a one to the grave, as dying of hydrophobia, who never had it, but had been bitten by a healthy and harmless animal.



## SPECIAL HEMORRHAGES.

Bleeding from the nose, in children, is often nature's way of getting rid of an excess of blood; but it may be so profuse as to threaten life. If this be the case, salt-and-water or vinegar may be snuffed up the nose, injected by a fountain-syringe, or applied by pouring with the head thrown back. A strong solution of alum in very warm water is also useful; but vinegar is less disagreeable, and will seldom fail to check the bleeding. In rare cases the nares must be plugged.

In hemorrhage from the lungs the blood is bright red and generally frothy. It is rarely profuse, and yet, as it is usually coughed up and caught in a handkerchief, it seems to be so. The amount can never be safely estimated in this way. The best treatment is rest in bed with the body raised in the sitting posture, and the swallowing of lumps of ice. The application of cold to the chest, if the patient is not too weak, is of some use, and a saltspoonful of salt and a teaspoonful of vinegar may be given every fifteen minutes. Five-grain doses of gallic acid may be very serviceable.

In hemorrhage from the stomach the blood is usually very dark, looking like coffee-grounds. If it is mixed with any other contents of the stomach, its appearance may be masked. In such cases ice-water or broken ice may be swallowed, and teaspoonful doses of vinegar. Rest in bed must, and the application of cold to the stomach may, be employed, with tannic acid in five-grain doses.

Hemorrhage from the bowels may be treated with ice-water injections, the application of ice to the abdomen, and five-grain doses of tannic acid.

In severe hemorrhage, rest in bed, without a pillow, and *with the head lower than the body*, must also be secured.

## POISONS.

As it is better to prevent accidents than to correct them, it is a good plan to have dangerous articles kept invariably out of reach of children, and to have any bottle containing what may be dangerous marked by a ball and chain, such as the druggists sell, or by tying a stout piece of tape round its neck. This gives warning in the dark as well as in the light.

When there is reason to believe that a child has taken a poison of some sort, it may be known what has been taken, or it may not be known. We will consider first

**Unknown Poisons.**—If the child should vomit, this should be encouraged; if not, it must be provoked. The simplest way to do this is to give large draughts of lukewarm water, and to titillate the fauces. If there is time, and it is at hand, a teaspoonful or two of ground mustard may be stirred up in the water, or a teaspoonful of powdered ipecac, or a tablespoonful of the syrup of ipecac. There is no occasion for fastidiousness. Any water will do. Water in which hands—or dishes, for that matter—

have been washed, may by its very repulsiveness act more quickly than anything else ; and if soap has been used, it will be all the better for that, as soap is an antidote for acid poisons. The quantity used must be large ; the sufferer must be urged to drink and drink, a large quantity at a time, until he can contain no more, and has been made to vomit over and over again.

After copious vomiting, soothing liquids should be given,—oil, milk, beaten-up raw eggs,—all in moderately large quantities. These are especially valuable when the poison has been of an irritating character.

If the sufferer be much depressed, some stimulant may be administered. Strong, hot tea, without milk, is the best, because it is a chemical antidote to many poisons. Strong coffee is next in value. To either of these can be added brandy, whiskey, wine, or alcohol, in half-teaspoonful doses, mixed with a little hot water. Warm coverings are not to be forgotten ; and if the depression be great, hot-water cans or hot bricks, wrapped in one or two thicknesses of blanket, should be laid by the side of the chest, or a large poultice placed round the body, or a blanket wrung out of hot water and covered with a dry one.

**Mineral Acids.**—For these the proper treatment is to give an alkali. A tablespoonful of hartshorn may be mixed with two teacupfuls of water, and given ; or almost unlimited quantities of soda, magnesia, potash, white-wash, chalk, tooth-powder, whiting, plaster, soap, or even wood-ashes, stirred up in water. After this should come the provoking of vomiting ; then the bland fluids mentioned above should be administered, rest secured, and stimulation employed if necessary.

**Oxalic Acid.**—For this the best antidote is lime in some form. If lime-water is at hand, it may be given freely, or whitewash, tooth-powder, chalk, whiting, or plaster from a wall. The latter may be crushed and stirred up in water, without regard to the grittiness, which will not do any harm.

**Carbolic Acid** is a very dangerous poison, because it acts rapidly and benumbs the stomach, so that it is hard to provoke vomiting. This must be attempted, however, and large draughts of oil, white of egg, magnesia and water, or milk must be given. Rest, warmth of the body, and stimulation must also be secured.

**Alkaline Poisons.**—Strong alkalies must be combated with an acid. Vinegar can always be had, and there is nothing better. It should be given undiluted and in large quantities. Lemon-juice may be used, or even orange-juice, though the latter is too mild an acid to be of much service, unless the oranges are very sour. Vomiting should then be provoked, and followed by bland drinks, rest, and stimulation if necessary.

**Arsenic** usually excites vomiting and violent pain in the stomach. At once large quantities of milk, white of egg, flour-and-water, or oil and lime-water must be given. The vomiting must be encouraged or provoked, and dialyzed iron should be given freely, in tablespoonful doses, each dose being followed at once by a teaspoonful of common salt in a teacupful of water ; or, if this is not at hand, equal parts of sulphate of iron and of

carbonate of sodium may be dissolved in separate cups of hot water and then mixed and drunk. Afterwards vomiting should be again provoked, and followed by a dose of castor oil.

**Acetate of lead** calls for vomiting, Epsom salt, milk, eggs, and castor oil.

**Corrosive Sublimate.**—When this is taken, vomiting must be provoked, and some form of tannic acid given. Strong tea is the handiest thing containing this, and its administration should be followed up with eggs and milk.

**Tartar emetic** is best treated in the same way.

**Phosphorus** is sometimes chewed off matches by children. It is a poison which acts slowly. Five-grain doses of sulphate of copper dissolved in water may be given, at intervals of ten minutes, until vomiting comes on. Then a dose of magnesia should be administered, but *no oil*.

**Nitrate of Silver.**—The antidote for lunar caustic is a very strong brine of salt-and-water, given again and again; and vomiting should be provoked until the vomited matters cease to have a look like thin milk.

**Iodine**, in the form of a tincture, is also sometimes swallowed by mistake. The antidote for this is starch-and-water.

**Opium preparations**, such as opium, morphine, laudanum, paregoric, black drop, must be combated with emetics, used promptly. Strong coffee must be freely given as a stimulant. So long as the breathing does not fall below ten to the minute, there is no *immediate* danger of death; but the important matter is to keep up the breathing. The custom of walking a patient up and down and slapping him with wet towels is to be deprecated, because it adds exhaustion to stupor. If an electrical battery can be obtained, the faradic current should be used, and applied so as to stimulate the sensory nerves in the skin, so that they shall excite reflex acts of deep breathing. The next best thing is to lay the patient upon a lounge and slap his skin with the back of a broad brush or with a slipper. This is all the rousing that is necessary, so long as the breathing keeps above ten to the minute. Should it fall below this, or if the breathing should cease, artificial respiration should be employed.

**Chloral.**—The treatment for chloral poisoning is the same as for poisoning by opium.

**Strychnine poisoning** should be treated by provoking vomiting, giving a purge, and doses of fifteen grains of bromide of potassium or ten grains of chloral, or both. The greatest quiet must be secured. The poisoned person should be put to bed in a darkened room, with doors, windows, and shutters arranged in a way that shall exclude all sights, sounds, and draughts, though permitting good ventilation.

**Aconite.**—In case of aconite poisoning vomiting must be brought on, and followed by the administration of stimulants. Strong coffee may be used, hartshorn (a teaspoonful in a teacupful of water), wine, whiskey, or brandy. If there is depression, warmth should be used, as described when speaking of unknown poisons.

*Veratrum viride* poisoning is to be treated like aconite poisoning.

Hemlock, deadly nightshade, the Jamestown (or jimson) weed, monkshood, and toadstools are sometimes eaten, without knowledge of their poisonous character. Tobacco, too, sometimes causes poisonous effects. All produce deep depression, and must be treated by the induction of vomiting, if it has not already occurred, followed by stimulation and warmth, very much as in the case of aconite poisoning.

Alcoholic liquors are sometimes taken in such large quantities as to be poisonous. When this is the case the course to be pursued is to cause vomiting, give hartshorn-and-water (a teaspoonful in a teacupful), and keep the body warm.

Decayed meats or vegetables usually excite vomiting, which should be encouraged till the stomach is empty, and followed by a dose of castor oil and some powdered charcoal.

In conclusion, let it be remembered that when there is an alarm of poisoning it is important to *keep cool*. In many cases of poisoning there is much more alarm than danger. Death from accidental poisoning is very rare. To save time in an emergency, the following table may be consulted, which gives the name of each of the poisons we have already studied, and the proper treatment for it.

POISON.	TREATMENT.
<i>Unknown</i> . . . . .	{ Provoke repeated vomiting ; Give bland liquids ; Stimulate, if necessary.
<i>Acids :</i>	
Sulphuric, } . . . . .	{ Give an alkali ;
Nitric, } . . . . .	{ Provoke vomiting ;
Muriatic, } . . . . .	{ Give bland liquids ;
Oxalic, } . . . . .	{ Secure rest ;
Carbolic, } . . . . .	{ Stimulate, if necessary.
<i>Alkalies :</i>	
Hartshorn, } . . . . .	{ Give an acid (vinegar) ;
Soda, } . . . . .	{ Provoke vomiting ;
Potash, } . . . . .	{ Give bland liquids ;
Lye, } . . . . .	{ Secure rest ;
	{ Stimulate, if necessary.
<i>Arsenic :</i>	
Paris green, } . . . . .	{ Provoke vomiting ;
Scheele's green, } . . . . .	{ Give dialyzed iron and salt ; } repeat several times ;
	{ Give dose of castor oil ;
	{ Secure rest ;
	{ Stimulate, if necessary.
<i>Acetate of Lead :</i> } . . . . .	{ Give Epsom salt ; } repeat several times ;
Sugar of Lead, } . . . . .	{ Provoke vomiting ; } repeat several times ;
	{ Give bland liquids ;
	{ Give dose of castor oil.
<i>Corrosive Sublimate,</i> } . . . . .	{ Provoke vomiting ;
<i>Tartar Emetic,</i> } . . . . .	{ Give strong tea, without milk ; } repeat several times ;
	{ Give raw eggs and milk ;
	{ Give dose of castor oil ;
	{ Stimulate, if necessary.

POISON.	TREATMENT.
<i>Phosphorus</i> . . . . .	{ Provoke vomiting ; Give five-grain doses of sulphate of copper, or teaspoonful doses of turpentine.
<i>Nitrate of Silver</i> . . . . .	{ Give dose of magnesia, but <i>no</i> oil. Give strong salt-and-water ; } repeat many times. Provoke vomiting ;
<i>Iodine</i> . . . . .	{ Provoke vomiting ; Give starch-and-water ; Give bland fluids.
<i>Opium :</i> Morphine, Laudanum, Paregoric, etc., <i>Chloral,</i>	{ . . . . . { Provoke vomiting repeatedly ; Give strong coffee, without milk ; Keep up the breathing.
<i>Strychnine</i> . . . . .	{ Provoke vomiting once or twice ; Give a purgative ; Secure absolute quiet.
<i>Aconite,</i> <i>Veratrum Viride,</i>	{ . . . . . { Provoke vomiting ; Stimulate well ; Keep head low.
<i>Jamestown Weed,</i> <i>Hemlock,</i> <i>Nightshade (belladonna),</i> <i>Toadstools,</i> <i>Tobacco,</i>	{ . . . . . { Provoke vomiting ; Stimulate well.
<i>Alcohol</i> . . . . .	{ Provoke vomiting ; Give hartshorn-and-water.
<i>Decayed Meat or Vegetables</i> . . . . .	{ Provoke vomiting ; Give a purgative ; Give powdered charcoal.

To provoke vomiting, warm water may be used, with or without ground mustard (a teaspoonful to half a pint of water), or ipecacuanha (a teaspoonful of the powder or a tablespoonful or so of the syrup), and titillating the fauces. It is best to give large quantities (half a pint at a time) of warm water whenever vomiting is to be excited.

Bland liquids are milk, raw eggs, some sort of oil, gruel, etc.

Stimulants are tea, coffee, whiskey, wine, etc., or hartshorn-and-water. A teaspoonful of hartshorn in a teacupful of water will be enough for a dose. In making tea or coffee one must not wait to do it as if for the table, but mix hot water and the leaves or grounds, squeeze them well, stir together, and give the whole,—leaves, grounds, everything. At the same time, some may be made regularly, if there are conveniences for it.

Alkaline antidotes are hartshorn-and-water (a tablespoonful in two teacupfuls of water), soap-and-water, lime, whiting, soda, chalk, tooth-powder, plaster, magnesia, whitewash, and even wood-ashes.

Acid antidotes are vinegar and lemon-juice.

In giving an antidote, never wait for it to dissolve. Just stir it up in any fluid at hand, except oil, and have it swallowed immediately.

# PLASTIC SURGERY.

By THOMAS G. MORTON, M.D.

---

THE term "plastics" or "plastic surgery" has been made to cover a wide range of procedures which are in the main reparative, formative, or reconstructive; in other words, such as have for their primary or principal object the remedying of natural physical defects, or the restoration of lost tissues or organs or parts of organs, including operations extending from skin-grafting to transfusion of blood.

Although such operations are occasionally referred to in the writings of the ancients, and have been practised by the Hindoos and Egyptians from time immemorial,<sup>1</sup> it has been only during the last half-century that general surgery has advanced to a position that would permit the development of plastic surgery into a distinct department of medical science. Stimulated by the subcutaneous division of tendons by Stromeyer, about 1831, and by the discovery of skin-grafting by Reverdin, in 1869, plastic surgery may be said to have entered upon a new era with the advent of anæsthetics and antiseptic methods into surgery. By the former, absolute control of the patient is afforded; by the latter, the successful result (or at least the prevention of suppuration) can generally, if not invariably, be assured. At the same time, the proportion of cases requiring plastic operations is very much smaller than formerly, because the methods pursued in the modern treatment of wounds prevent suppuration and loss of tissue after operation; and, since mercury is now given with less freedom, instances of ulcerative stomatitis with sloughing of the lips or cheek rarely, if ever, occur. Plastic operations are infrequent in children, and most of them will be found described elsewhere in this work under appropriate headings,—“Congenital Defects and Deformities of the Face, Lips, Mouth, Tongue, and Jaws,” “Hare-Lip and Cleft Palate,” “Congenital Affections of the Bladder and Penis,” “Club-Foot and Torticollis,” “Deformities of Bone,” etc.,—and need not be further referred to in this paper.

The principles involved in plastic surgery of childhood in no way differ from those governing similar operations at any other period of life.

The preparatory treatment is all-important: indeed, we may lay down

---

<sup>1</sup> Ashhurst's *Encyclopædia of Surgery*, vol. i.

the rule that a condition of the tissues favorable to repair is absolutely necessary for a successful result. A plastic operation should not be considered, nor undertaken, unless the disease necessitating it is practically eradicated.

The conditions of the operation and surroundings and the after-treatment likewise should be such as will most readily conduce to success. Sufficient care must be exercised to secure rest for the part operated upon and proper nourishment to the transplanted tissue; there must also be no strain upon the flap, which should be of ample proportions; and, moreover, thorough antiseptic precautions should always be carried out.

Congenital defects do not generally yield as good results as acquired ones; but it is to be observed that where the skin has been destroyed by burns or scalds, the new tissue never exhibits the same anatomical characters as the old, and usually does not possess the vitality of the surrounding skin. Operations requiring transplantation of flaps of skin are rarely performed at the present day. On account of the miserable results obtained by the rhinoplastic and other methods of restoring lost noses, such operations are held in rather low estimation, and the opinion gains among operators of most experience that the very admirable artificial noses which are now made are in every way superior, and, when compared with the results of rhinoplasty, far less objectionable.

In performing plastic operations the operator should avail himself of true skin in order to have a successful result. Skin-grafting, by using small pieces of epidermis or scrapings of the skin, in the treatment of ulcers, is a well-established procedure in surgery, and need not be described, as it is performed in the child in precisely the same manner as in the adult. The same may be said of transplantation of bone-fragments in cases of ununited fracture, to replace osseous tissue and stimulate union where the ends of the divided bone are even widely separated. An extemporaneous plastic operation is occasionally required when the edges of a wound will not approximate unless with an extreme amount of tension, which may be sufficient to threaten the vitality of the flaps. In such a case part of the wound may be left to granulate and gradually cicatrize, or the operator may at once transplant a portion of skin to fill up the cleft and thus avoid the production of a large or a contracted cicatrix. Where this is not done at the time of operation it may be resorted to later, as by Reverdin's method of transplanting skin upon the surface of open wounds. The same procedure may be called for after there has been absorption of the flap or loss of part of it from gangrene.

Recently efforts have been made to improve vision by transplanting the healthy cornea of the rabbit upon the human eye, but thus far the operations which on several occasions have been performed have not been attended with any success. When the graft has become vitalized it has become opaque; it is not only useless, but is also a blemish, even worse than the condition it was designed to remedy.

There are some precautions to be observed in operations requiring transplantation of flaps of skin, such as those performed to save an eyeball from destructive inflammation, those to remedy various deformities of the eyelids by scars, those to afford relief in cases of exstrophy of the bladder, etc. The flaps should in all cases contain a fair supply of blood-vessels and cellular tissue, they should be large enough to allow for shrinkage, and scar-tissue should be avoided. When it becomes necessary to twist the flap, great care should be taken that it be placed so as to avoid all tension, or, if that is impossible, so as to exert the least possible strain, in order that there shall be little or no interference with the circulation; all tension is injurious. Large blood-clots should be removed, so that there shall be fairly close approximation of the raw surfaces; and strict antiseptic precautions should prevail.

In performing the open incision for club-foot, often a wide gap is left when the deformity is corrected, and incident to the healing of this considerable contraction occurs: to avoid this and a recurrence of the varus, I have suggested and performed transplantation of a flap of skin from the dorsum of the foot.

**Dressing.**—Unusual care should be observed by the surgeon and his assistant as to personal cleanliness and the preparation of the necessary instruments and dressings. The mercuric-chloride solutions afford the greatest protection, and should be freely used before, during, and after the operation. While the operation is in progress a douche of distilled or recently-boiled water can be substituted for the mercuric solution.

All the instruments should be boiled before being used, and all ligatures, carefully selected and prepared for the operation, should be kept in a weak carbolic solution. The line of sutures after the wound is closed, as well as the drain, should be covered by a narrow strip of protective; the gauze dressing, wrung out of a weak mercuric solution, is next applied; the gauze bandages should be of a light, fine, soft material, and also kept in a weak mercuric solution. Where there is a probability of considerable oozing, the dressing should then be covered with bichloride absorbent cotton, and this retained in position by dry, gauze, bichloride bandages. Very free or troublesome oozing of blood from the raw wound-surfaces may be readily controlled by the use of hot water or of a solution of the peroxide of hydrogen. It is always better to avoid ligatures if possible; if necessary, fine gut should be used. Occasionally a drain of gut, or in certain cases one of rubber, may be required. Owing to the irritability of the skin in children, only very weak solutions of bichloride of mercury (one in three thousand or one in four thousand, or even of less strength) should be employed. The field of operation should be surrounded by towels wrung out of warm mercuric solution. Before the operation the wound and the skin to be transplanted should always be carefully cleansed with soap and water, the surface shaved, then washed with turpentine and ether, and lastly well doused with the mercuric solution; in other words, the strict antiseptic precautions which are demanded in all surgical operations should be adopted.



By this means immediate union of the transplanted tissues is generally secured, which is particularly important in all plastic work.

In this place it will not be necessary to describe in detail the manner of executing the various formative or plastic operations, or to discuss further the technique of the dressing of the wound. It is proper to state, however, that if the operation be of any gravity an anæsthetic will be required, in order to prevent the surgeon from being disturbed by the cries and struggles of the little patient. Nitrous oxide does well for short operations; in more protracted ones chloroform or ether may be used,—preferably the latter. Chloroform, however, is far less dangerous in infancy than in later years, but under any circumstances it should be given with great care and a very free admixture of air allowed, so that the vapor of chloroform shall not be present in the inspired air in larger proportion than from three to five per cent. For tedious operations the best washed ether should alone be used. In such as promise to be unusually protracted, mixed anæsthesia may be resorted to, either by the preliminary administration of alcohol (whiskey, brandy, or wine) or by the method of Nussbaum,—the hypodermic injection of morphine. In the latter case, on account of the well-known want of tolerance of children to morphine, the dose should be very small, and might properly be accompanied by atropine; or in very young children atropine alone, or belladonna, should be administered in place of morphine. However, in the use of such agents in children for this purpose the writer has no personal experience to speak from.

Plastic operations are called for in children for two classes of cases,—(1) to correct congenital malformations or deformities, and (2) to remedy lesions resulting from disease or traumatism.

Of the former class the following may be cited: 1, webbed fingers and toes, and the like; 2, hare-lip and cleft palate; 3, imperforate anus, nares, or auditory canal; 4, exstrophy of the bladder; 5, congenital hernia; 6, spina bifida; 7, sinuses, branchial and others; 8, various malformations of the genital organs; 9, abnormalities of the eye and its coverings; 10, some conditions of club-foot, etc.

Among the lesions produced by disease or traumatism requiring plastic operations in childhood the most frequent are—1, contracting cicatrices (from burns, caustics, ulcers, etc.); 2, loss of portions of the body by sloughing (as of the lips, cheeks, or vulva) from the abuse of remedial agents (mercury), or following acute eruptive fevers (measles, small-pox, etc.); 3, mutilation or loss of parts of organs by traumatism (ears, nose, lips, etc.), or the development of fistulous tracts after various forms of disease or injury (urethral, perineal, etc.).

# WOUNDS.

By JAMES McCANN, M.D.

---

THE injuries to which children are liable do not differ in any important feature from those which are sustained by grown persons. In their immediate effects, however, as well as in their remote consequences, there are many points of divergence.

Shock—"that depression of all the vital functions which follows a severe injury," at all periods of life—is peculiarly intense in early childhood, especially when associated with terror, long-continued and severe pain, exposure to cold, or loss of blood. Reaction, however, is usually prompt, and when once fairly established is not followed by the fatal secondary depression so often encountered in the injuries of adults.

In its mildest form it appears as a mere temporary disturbance of the functions of the nervous system, manifested by dizziness, faintness, and trembling. This mild form disappears spontaneously. In its severer form it causes symptoms of the most alarming character, indicating the peril in which the child is placed. These symptoms are usually very characteristic. "All the nervous and circulatory functions are in a state of collapse." The child lies in a state of semi-stupor, or tosses from side to side in extreme restlessness. The face is usually pale and death-like, the lips livid, the eyes glassy, the body cold and damp with perspiration, the pulse small, very frequent, feeble, or imperceptible, and the respiration shallow, sighing, or moaning; convulsions are not uncommon in very young children. Thirst is generally a distressing symptom (when the stupor is not too profound), and the efforts to relieve it are frequently rendered ineffectual by persistent vomiting. Death may occur from shock alone, independent of hemorrhage, extent of injury, or lesion of important viscera. Fortunately, this perilous condition is usually of short duration; reaction soon appears, the pulse becomes fuller and stronger, warmth returns to the body, and the face regains its normal color and expression.

When shock is severe, reaction should be hastened by placing the child in a perfectly horizontal position, with the head low, and by the application of dry warmth to the extremities and the administration of diffusible stimulants. Brandy or whiskey in half-teaspoonful doses may be given every half-hour or hour to a child of two years, with hot milk or broth, and, if

the depression be extreme, large enemata of water at a temperature of 106–110° F. should be used. All bleeding must be checked, for continued hemorrhage, even if moderate, will greatly delay reaction.

Acute pain, which is so distressing a symptom of many injuries at all ages, is especially depressing in its effect in childhood, and tends to prolong and intensify shock. Hence anodynes and anesthetics are often required to lull the pain following an accident, as well as the inevitable suffering caused in the dressing of severe injuries.

Primary hemorrhage is at times very disastrous in its immediate effects in early childhood: all the tissues are exceedingly vascular, and every severed vessel bleeds furiously. The flow of blood, however, is nearly always easily controlled, and, once arrested, shows little tendency to recur.

Secondary hemorrhage is very rare except when there is extensive and rapidly-destructive ulceration or suppuration. The hemorrhagic diathesis is not peculiar to early life.

Although rather high febrile excitement follows all severe injuries and operations in childhood, its duration is brief, and gangrene, ulceration, and profuse suppuration, as immediate results of injuries, are very rare except when the main vessels and nerves of the limb are destroyed, the tissues reduced to a pulp, or a joint penetrated. Children are, indeed, remarkably free from those profound traumatic constitutional disturbances so commonly met with in the adult; and hence sapræmia, septicæmia, and pyæmia are less frequent and less formidable complications of injuries, while the severe forms of erysipelas and phagedæna are almost unknown. Mild or cutaneous erysipelas, however, is not very uncommon.

While there is marked freedom from all the lethal complications which so commonly follow severe injuries in the adult, the remote effects manifest themselves by various structural changes. Chronic indurations and low sluggish forms of inflammation, ending in caseous degeneration or in tedious and exhausting suppuration, are common sequels of wounds in children. Not infrequently the damaged part becomes the focus of malignant degeneration, especially sarcoma.

Owing to the perfection of the nutritive processes and the almost universal absence of the visceral and vascular degenerations common in adult life, repair goes on in childhood with surprising rapidity and perfection; the most extensive wounds heal quickly and uninterruptedly, even in very unfavorable cases; badly bruised and torn structures retain their vitality, or regain it when apparently devitalized, and are often unexpectedly reunited. So intense is the physiological activity of the tissues of the child that repair after injury, except in very extreme cases, can be confidently looked for, and no tissue should ever be hastily sacrificed, no matter how badly it appears to be damaged. When an entire limb is so badly mangled that it is doubtful whether it is wiser to try to save it or proceed at once to amputation, the advice of Mr. Holmes should be followed: "In compound fracture, amputation should never be practised except when the limb is

hopelessly crushed and disorganized. In all doubtful cases the limb ought to be preserved until the onset of gangrene renders the effort to save it no longer justifiable."<sup>1</sup>

The bad sanitary conditions which surround the children of the poor exert no markedly injurious influence upon the healing of their wounds. The so-called "strumous" or scrofulous diathesis cannot be regarded as militating against necessary operations, nor as retarding recovery after accident. The success which follows removal by operation of the profusely-discharging surfaces of chronic suppurative synovitis or ulcerating glands affords striking evidence of the power which children possess not only to repair injuries and to recover from formidable operations, but also to regain health as soon as the source of irritation and exhaustion is removed.

#### REPAIR OF WOUNDS.

The healing process in all varieties of wounds is accomplished by changes in the nutrition of the parts, which result in the development of new tissues from material supplied by the old. "A wound is a solution of continuity of the external soft parts." The newly-formed tissue is the bond that unites the divided parts which retain or regain their vitality, and makes good the loss of tissues disorganized beyond recovery by the original violence or subsequent suppuration. The quantity of new tissue, obviously, varies greatly in different wounds. The healing process, though essentially the same, varies considerably with the quantity of tissue lost, the treatment employed, and the special circumstances of the case. The new tissue is at first embryonic, and then passes rapidly through the intermediate stages of development to the mature tissues of the cicatrix. The original structures surrounding the wound also return more or less to the embryonic condition and become continuous with the new tissues uniting them. The whole complex process may be regarded as "growth followed by organization."

Whatever determines the variations of the healing process, clinically it follows one or other of five methods,—viz., first, by immediate union; second, by primary adhesion, or union by first intention; third, by granulation, or union by second intention, accompanied often by suppuration; fourth, by union of granulations; and, fifth, by union under a scab. This is the classification of Macartney, and is adopted by Paget.

1. **Immediate union** is extremely rare, though occasionally secured in clean incised wounds which are promptly and accurately coaptated and kept absolutely at rest. The divided ends of the various structures in the opposite walls of the wound unite again immediately, without appreciable inflammation or febrile excitement. They become continuous without the development of a bond of new tissue between them, and the process is, of course, free from the symptoms arising from its development and the acci-

<sup>1</sup> Surgical Diseases of Children, p. 242.

dents which befall it. The time required is much shorter; union is complete in from twenty-four to forty-eight hours, and there is no visible scar. This method of union requires an almost unattainable accuracy in the adjustment of each severed tissue, the wound itself must be absolutely free from all foreign bodies, blood, or clots, and there must be perfect asepsis. It is the ideal mode of repair, and should always be sought, but can very rarely be attained.

2. **Union by primary adhesion**, "adhesive union," or "healing by first intention," is the most frequent as well as the best attainable method of repair of incised wounds. It is less frequent in other forms. Following every wound in which the conditions requisite for immediate union do not exist, there is a brief period of calm, during which all the hemorrhage ceases and the reparative processes have not begun. This stage of quiescence is quickly succeeded by an active dilatation of the vessels in the vicinity, and by a copious migration of leucocytes, red blood-corpuscles, and hematoblasts from the gorged capillaries, which together with the exuded liquor sanguinis infiltrate the tissues immediately surrounding the wound and appear as a glossy film, "glazing" its surfaces. In a few hours this glazed appearance changes first to a grayish and then to a pinkish white, and a covering of soft adhesive material is visible on the surface. Organization has now begun in the exudate. This covering is embryonic granulation-tissue, which the microscope shows to be rich in lymph-corpuscles and other cells in various stages of development into the types found in mature granulation-tissue. The borders of the wound now become swollen, soft, and juicy, its lips pout, and a serous or sero-sanguinolent fluid escapes from it. If it is aseptic, and at this stage its edges be accurately approximated, they will unite by a process not very different from immediate union. Ordinarily this is prevented by a film or clot of blood, which, although affording some protection against putrefaction and serving to hold the wound together, prevents close contact of its walls, and consequently repair cannot be perfect until it disappears or is removed. Its removal is effected very soon by natural processes. The clot is rapidly infiltrated by leucocytes, the red corpuscles disappear, the fibrinous net-work which formed its basis softens and is in part changed into a homogeneous mass which blends with the lymph covering the wound-surfaces. The round cells of the exudate very early become club-shaped, fusiform, or branched, with attenuated extremities which arrange themselves in interlacing bundles. In this way the opposite surfaces of the wound are brought together by new fibro-connective tissue.

Vascularization occurs by the development of new capillaries in the organizing exudate from the dilated and tortuous vessels of the walls of the wound. Starting probably from their endothelial cells, bud-like offshoots are seen very early in the evolution of the new tissue; a little later, thread-like processes push their way through the soft embryonic granulation-tissue uniting the wound until they meet other processes like themselves or the

original capillaries. They join at the point of contact; the central portion liquefies, forming a tube continuous with the lumen of the capillaries on each side. The new channels at first transmit only plasma, but soon dilate enough to permit the corpuscles to pass. The walls of these rudimentary capillaries acquire strength through the adhesion of new particles of protoplasm and the rapid development of fibroblasts upon their free surface. Endothelial plates are developed from the leucocytes which adhere to the inner surface of the new-formed vessel. A new vascular bond is thus formed, rudimentary at first, but in a few days presenting all the histological peculiarities of the normal capillaries.

As the new bond of union organizes and becomes vascular, the cells of the skin at the margins of the wound proliferate rapidly. Owing to the constant tendency of all impaired tissues to reproduce structures similar to the part lost, young epidermic cells are formed. Their presence is indicated by a bluish-pink line bordering the edges of the wound and advancing towards the central line, where union of the opposite borders occurs, which completes the scar superficially. Organization in the deeper parts is slower, and is followed by contraction of the new fibro-connective tissue. The general obliteration of the new capillaries by this contraction restores the part to its normal color.

3. **Healing by granulation**, or by second intention, occurs when, as a result of improper closure of the wound, of too long exposure of its surface to the air, of loss of substance, or of extent of injury, repair by the methods just described fails. Hemorrhage is arrested by coagulation of the blood in the injured capillaries, extending as far as their first branches. A temporary local stagnation comes first, which effectually stops all bleeding. An exudate from the vessels poured out into the perivascular and interstitial spaces bathes the surfaces of the cavity of the wound and saturates the dressing with a thin, reddish-yellow, serous or sanious fluid.

If this fluid is allowed to become infected, it decomposes, and irritates the wound, and may give rise to constitutional septic infection. The discharge in this case is converted into pus, and the unfortunate change is betrayed by the offensive odor coming from the dressings. When it escapes infection, the exudate coagulates, and covers the surface with a grayish-white or ashy gray, viscid, albuminous film of plastic lymph. The connective-tissue corpuscles and muscle-cells proliferate with great rapidity. The surrounding tissues become gelatinous, and the edges are hot, swollen, and juicy. New capillaries are formed from the old; those nearest the surface travel in the direction of least resistance, push their way in vascular loops into the soft adhesive glaze which covers the wound, and appear as minute red points dotting its surface. These new capillary loops return the blood to the parent vessels.<sup>1</sup>

---

<sup>1</sup> Hamilton, of Aberdeen, in his recent work, "Text-Book of Pathology," declares that these vascular loops are merely the original capillaries elongated by the blood-pressure no longer counteracted by the tension of the skin.

This process continues until the entire wound-surface is transformed into a soft, ruddy, highly vascular mass of embryonic granulation-tissue, which blends intimately with the underlying structures. An active outgrowth of epithelioid cells or fibroblasts, derived undoubtedly from the proliferating connective-tissue corpuscles, together with a part of the migrated leucocytes, develops into bundles of interlacing fibrils and forms a framework of young fibro-connective tissue throughout the granulating surface.

Thus far the process is perfectly physiological: the thin film which covers the granulations, though it may be rich in dead leucocytes, is bland and unirritating, and free from micro-organisms. It is strictly a dead inflammatory exudation, but not suppuration. Suppuration forms no necessary part of the healing process; its occurrence indicates that pathological changes have supplanted physiological repair, and that the wound is no longer aseptic.

It is inevitable that a part of the superficial formative elements should lose their vitality, because of their remoteness from the channels of nutritive supply, the mechanical irritation of the dressings, or the corrosive effects of the antiseptics with which they are charged. This debris, mingling with the sanguinolent serous fluid which moistens the surface of the granulations, appears as a discharge, seldom abundant in purely aseptic wounds. When present it is a pinkish-yellow, watery fluid, which under the microscope shows the presence of dead leucocytes, in this respect resembling pus; but the fluid differs from that of suppuration, in the absence of specific micrococci, which are an essential etiological factor of the latter process.

If contact with unsterilized instruments or other objects or with the atmosphere—which usually contains the *staphylococcus pyogenes aureus*, *albus*, and *citrens*, or the *streptococcus pyogenes*—is not avoided, these micro-organisms, finding a suitable habitat, increase rapidly in numbers, and, irritating the surface of the granulations, cause increased vascularity and an abnormal outflow of plasma, leucocytes, and the like. Under their influence the leucocytes die and become pus-corpuscles, and the exuded elements are rendered incapable of coagulation; the granulations are covered with a film of so-called laudable pus, which greatly retards the healing process, though it seldom prevents it.

Cicatrization commences by the generation of young epidermic cells from the old ones at the margins of the wound. The young cells are more or less rounded in form, and resemble those of the rete Malpighi. "They do not really adhere to the underlying surface, but throw down long processes, which pierce the tissue underneath, and thus adhere to it."<sup>1</sup> They give rise to a bluish-pink film or pellicle, which gradually spreads from the margins over the granulations until the whole surface of the wound is covered by a rudimentary epithelium. The process is hastened by the contraction of the new connective-tissue in the deeper parts of the wound,

---

<sup>1</sup> Hamilton, op. cit.

which draws its edges together. This process of deep cicatrization continues until repair is complete in the entire wound. The scar is larger and more distinct than that which follows in healing by primary adhesion, but without other difference. The color is restored in the same way, by obliteration of the capillaries, which is often so complete that the scar is white and appears bloodless. It becomes pliable and elastic, but remains during life.

When devitalized tissues or foreign bodies are retained in the wound, the healing process is retarded. If the wound can be kept in a perfectly aseptic condition, and is properly drained, the growth of new granulation-tissue goes on uninterruptedly; the devitalized tissue is separated from the living structures by the formation of a border of young granulations,—“a zone of demarcation,”—and the dead portion occupies a position on the surface somewhat similar to that of a scab, and a species of “desiccation” goes on underneath. When an insoluble foreign body remains in the wound, it is first surrounded by a zone of inflammatory infiltration: this undergoes organization into granulation-tissue and then into a fibrous capsule, and the foreign body becomes encapsulated or encysted.

If, however, the wound is not properly drained, and if through imperfect antiseptics the retained discharges become infected by any of the germs of suppuration or putrefaction, inflammation is at once intensified, and increased exudation of leucocytes and plasma bathes the surface of the wound with pus. The dead tissues separate by an ulcerative process, purulent infiltration invades the surrounding structures, and the dangers of septic absorption and general blood-pollution are immeasurably increased.

4. **Repair by union of granulations**, or by “secondary adhesion,” occurs when two granulating surfaces are held in contact either by surgical appliances or by the growth of the granulations themselves. New connective tissue is formed and unites apposed granulations; and capillaries are formed by union of vascular processes derived from those of each surface. Cicatrization completes the process of repair by union of granulations.

5. **Healing under a scab**, or “subcutaneous cicatrization,” resembles union by primary adhesion, and, next to that, is the most favorable mode of repair. A perfectly aseptic wound is hermetically sealed by its own exudation. Blood and serum collect and dry upon the surface in such a manner as to form an impervious covering for the wound; air and septic materials are excluded, and the severed structures unite with an almost imperceptible degree of inflammation, and with the formation of a delicate and unindurated scar. The wounds of animals heal in this way. It is a very desirable mode of repair. The crusts which form on a wound, especially of the face, should not be disturbed until they become so loose as to be ready to drop off. If the scab be removed too soon, a second scab does not form, and the wound heals by granulation.



## DEFINITION AND CLASSIFICATION.

“A wound is a solution of continuity of the external soft parts, recent, and the result of violence.” For convenience, the wounds of children, like those of adults, are primarily divided into open and subcutaneous, and are further classified as incised, contused, punctured, and poisoned wounds.

---

## INCISED WOUNDS.

The incised wound is the form most frequently encountered. It is an injury inflicted accidentally or intentionally by any sharp-edged instrument or weapon, as a knife, razor, chisel, axe, sharp fragment of glass or bone, etc. The tissues are all smoothly severed, without appreciable injury to those in the immediate vicinity. The symptoms which distinguish incised wounds are pain, hemorrhage, and gaping or separation of the divided structures. The pain is usually sharp, cutting, and very severe at first, then burning or smarting, and finally subsides into a dull aching sensation, with more or less stiffness of the affected part. It varies in intensity in different portions of the body. Most painful are wounds of the face and lips, of the palms of the hands and soles of the feet, and of the arms and genitals. When severe and long continued, pain becomes extremely depressing and adds to the intensity of the shock.

Hemorrhage is always profuse at first, on account of the clean division of the blood-vessels; the blood pours from the whole surface of the wound; when an artery is divided, it spins or spurts furiously at single points in a bright red stream, *per saltum*, as if thrown from the nozzle of a syringe. Such a hemorrhage may soon destroy the life of a child. The blood from an incised or a divided vein wells up from the wound in a sluggish stream, dark purple in color, and accelerated during expiration if one of the large venous trunks in the neck is wounded, and death from hemorrhage or from entrance of air into the vein may occur before assistance can be obtained.

Gaping or separation of the edges depends upon the elasticity of the skin, the situation of the wound, and its relation to the fibres of the underlying muscles. Wounds which are transverse to the long axis of a limb gape more widely than those parallel to it, while if the underlying muscles be involved the retraction of the severed fibres will be greater than that of the skin, causing a deep cavity wider at the bottom than at the surface. Great care is required in closing such a wound, lest a pocket be left in which blood and discharges will collect, which not only prevent the healing process, but also, by decomposing, expose the patient to danger from septic absorption. Wounds of the face, when deep, display a great tendency to gape widely, because of the elasticity of the skin and its firm

arterial branches will usually require special measures,—the ligature, torsion, pressure, etc.

Torsion is certainly the most rapid, efficient, and safe method of permanently controlling hemorrhage at all periods of life, but especially in childhood, which the surgeon has at his command. An extensive experience with this measure in the surgical wards of the Western Pennsylvania Hospital has demonstrated its superiority over other methods of controlling hemorrhage, and fully confirmed Mr. Bryant's opinion of its value. During the past sixteen years it has been relied upon almost exclusively in that institution, and it has frequently been applied to the brachial, axillary, popliteal, and femoral arteries, to the arteries of the forearm and leg in amputations, and to the arteries after removal of the breast, and no case of secondary hemorrhage has followed its use. In one instance in my own practice secondary hemorrhage followed torsion of the interosseous artery, and a similar misfortune happened recently to another surgeon in this city; but in both cases there had evidently been some defect in the method of application. In the same period, in that hospital, two fatal cases of secondary hemorrhage followed the use of the ligature,—in one from the axillary artery after amputation at the shoulder for injury, in the other after disarticulation at the hip for disease.

The following table, collated by Prof. Murdoch, of Pittsburg, from the records of the Western Pennsylvania Hospital,<sup>1</sup> exhibits the frequency with which torsion has been employed in that institution for the control of hemorrhage from large arteries. It includes cases at every period of life, from early childhood to advanced age.

Femoral . . . . .	95 times.
Popliteal . . . . .	14 "
Axillary . . . . .	15 "
Anterior tibial . . . . .	276 "
Posterior tibial . . . . .	276 "
Brachial . . . . .	62 "
Radial . . . . .	40 "
Ulnar . . . . .	40 "
Total . . . . .	818 times.

Torsion is a very simple operation, requiring no special instruments for its performance other than the strong serrated (not toothed) artery-forceps carried by every surgeon. The ends of the divided artery should be caught in the jaws of the forceps, and the vessel drawn gently from its sheath, and twisted or rotated on its long axis until the feeling of resistance is overcome: five or six turns are usually sufficient. The brittle internal and middle tunics of the vessel break, curl up, and reduplicate themselves, forming a valve-like plug, while the elastic external coat twisted into a ball gives additional support. A firm clot forms within the vessel, and an

<sup>1</sup> Chicago Medical Journal and Examiner, June, 1889.

attachment to the subjacent muscles; and this tendency is aggravated by the violent contraction of the facial muscles when the child cries. Much patience and skill are required in closing these wounds, to prevent disfiguring scars; and sutures when used should be closely inserted, and reinforced by strips of aseptic adhesive plaster and carefully-adjusted compresses and bandages.

The shock which follows all forms of incised wounds depends for its intensity and duration upon the depth and location of the wound, the nature of the divided structures, and the presence or absence of hemorrhage. Reaction should be hastened by the measures set forth in the beginning of this article.

#### TREATMENT OF INCISED WOUNDS.

The primary object in the treatment of all wounds is to secure rapid, painless, and complete repair of the damaged parts. To accomplish this, an effort should be made to secure union by primary adhesion wherever possible. "*Union occurs in every aseptic wound the surfaces of which are brought into exact apposition.*" (Trélat.)

It is assumed at the very beginning that every detail of the treatment of all forms of wounds, from the moment of infliction until the end of the healing process, shall be carried out with the strictest regard to the conditions of asepsis. For this purpose it is absolutely necessary not only that the wound shall be clean, but also that the skin contiguous to it shall be thoroughly scrubbed with soap-and-water and afterwards bathed and irrigated with some antiseptic solution. The hands of the surgeon and his assistants must be rendered absolutely free from every possible source of contamination, all instruments, sutures, and the like, liable to come in contact with the wounded tissues, must be taken directly from a germicide solution, and the external dressings must be so charged with one or other of the many antiseptics now in use that they will protect the surface of the wound from contact with the air and prevent the occurrence of putrefaction in the discharges. Attention to details is of the utmost importance, and strict cleanliness is of far greater value than a cumbrous paraphernalia of instruments and dressings.

The indications of treatment are to arrest hemorrhage, to cleanse the wound, to provide for its drainage, to secure apposition of its surfaces, to protect it from the entrance of septic or putrefactive germs, and to secure absolute rest for the damaged part.

**Arrest of Hemorrhage.**—Although the blood pours out freely at first from the whole surface of an incised wound, its force soon abates, unless a large artery is divided. The ends of the smaller vessels contract spontaneously upon exposure to the air or to a stream of cold water, and cease to bleed. Elevation of the part and moderate pressure upon the surface of the wound hasten this result. Hot water—115° to 120° F.—produces a similar effect, by stimulating the divided vessels to contract, and possibly also by coagulating the albumen of the blood. Bleeding from larger

arterial branches will usually require special measures,—the ligature, torsion, pressure, etc.

Torsion is certainly the most rapid, efficient, and safe method of permanently controlling hemorrhage at all periods of life, but especially in childhood, which the surgeon has at his command. An extensive experience with this measure in the surgical wards of the Western Pennsylvania Hospital has demonstrated its superiority over other methods of controlling hemorrhage, and fully confirmed Mr. Bryant's opinion of its value. During the past sixteen years it has been relied upon almost exclusively in that institution, and it has frequently been applied to the brachial, axillary, popliteal, and femoral arteries, to the arteries of the forearm and leg in amputations, and to the arteries after removal of the breast, and no case of secondary hemorrhage has followed its use. In one instance in my own practice secondary hemorrhage followed torsion of the interosseous artery, and a similar misfortune happened recently to another surgeon in this city; but in both cases there had evidently been some defect in the method of application. In the same period, in that hospital, two fatal cases of secondary hemorrhage followed the use of the ligature,—in one from the axillary artery after amputation at the shoulder for injury, in the other after disarticulation at the hip for disease.

The following table, collated by Prof. Murdoch, of Pittsburg, from the records of the Western Pennsylvania Hospital,<sup>1</sup> exhibits the frequency with which torsion has been employed in that institution for the control of hemorrhage from large arteries. It includes cases at every period of life, from early childhood to advanced age.

Femoral . . . . .	95 times.
Popliteal . . . . .	14 "
Axillary . . . . .	15 "
Anterior tibial . . . . .	276 "
Posterior tibial . . . . .	276 "
Brachial . . . . .	62 "
Radial . . . . .	40 "
Ulnar . . . . .	40 "
Total . . . . .	818 times.

Torsion is a very simple operation, requiring no special instruments for its performance other than the strong serrated (not toothed) artery-forceps carried by every surgeon. The ends of the divided artery should be caught in the jaws of the forceps, and the vessel drawn gently from its sheath, and twisted or rotated on its long axis until the feeling of resistance is overcome: five or six turns are usually sufficient. The brittle internal and middle tunics of the vessel break, curl up, and reduplicate themselves, forming a valve-like plug, while the elastic external coat twisted into a ball gives additional support. A firm clot forms within the vessel, and an

<sup>1</sup> Chicago Medical Journal and Examiner, June, 1889.

exudation of plastic lymph cements the reduplicated tunics and renders the lumen of the artery impervious. Organization of the lymph soon follows, and all the structures are thus bound together in the cicatrix.

Easily and rapidly performed, torsion seems to be more absolutely safe than the ligature. The twisted ends of the vessel are not devitalized, and hence no dead tissue is left in the wound to slough or decompose, no foreign body to irritate, and no ligature to loosen, ulcerate, or slip. It is difficult to conceive of the necessity of any other method of controlling hemorrhage in the wounds of children, except in punctured wounds of large arteries, where both distal and proximal ends of the vessel must be dealt with; ligature is then the simpler and more convenient method.

*The Ligature.*—The ligature is a safe and efficient means of permanently controlling hemorrhage, but it is open to the objection that, no matter how carefully it may be applied, a foreign body is left in the wound, and the vitality of that portion of the ligated vessel which projects beyond the point of ligature is destroyed. A limited necrosis must result; the dangers of septic contamination are therefore greatly increased, and, unless careful antiseptics are observed, disaster is liable to follow.

Ligature of a bleeding vessel is accomplished by grasping its severed end with forceps and gently drawing it out from its sheath, so as to free it from the surrounding structures; the ligature is then thrown around the vessel close to the sheath, and tied with a single reef or sailor's knot, which is drawn tightly enough merely to divide the internal and middle tunics of the artery, without inflicting too great damage upon the external tunic. Both ends of the ligature are now cut short, and the ligated vessel is allowed to retract within its sheath. When bleeding from a number of small vessels situated close together persists, it is better to include them all in a single ligation than to waste time and blood in an effort to isolate each vessel.

The materials employed for the ligature of vessels are the same as those used for sutures, and the same scrupulous care should be taken to render them aseptic. Too great vigilance cannot be observed in this matter. Fine hard-twisted carbolized sewing-silk probably possesses as much merit as any other substance, and can always be obtained. Catgut, if properly prepared, is quite reliable, and is in time absorbed by the tissues. Greater care is required in tightening the knot, however, and the second turn of the knot should be reinforced by a third turn, as a guard against slipping of the ligature.

Pressure is useful as a temporary means of controlling hemorrhage, but it must be used cautiously, lest serious damage be inflicted upon uninjured parts. It should always be applied directly to the bleeding point, and not to the limb above the seat of injury, except during an operation, and must be removed as soon as other and more efficient measures can be employed. As a method of permanently controlling hemorrhage it is very unreliable and likely to end in failure. The practice of encircling a limb by a tourniquet to arrest bleeding is an exceedingly dangerous one, and in three cases

of which I have personal knowledge it was the direct cause of death, by producing gangrene in the limb. It should never be employed except during the performance of an operation.

Styptics are seldom required for the arrest of hemorrhage, and their use cannot be too strongly condemned. Unfortunately, it is the custom with some practitioners to resort to styptics in every case of active bleeding, and the wounds which fall into their hands are systematically daubed or tightly crammed with some styptic, most commonly the solution of the sub-sulphate or perchloride of iron. It is true that this treatment will arrest hemorrhage in many cases, though *not in all*; but, in doing so, it so irritates and befouls the wound that union by primary adhesion or "first intention" is absolutely impossible. Unreliable and unsafe, the use of styptics renders a clean cut surface unfit for rapid repair, adds to danger and suffering, and retards recovery. It is a practice dictated by timidity and ignorance, and ought to be abandoned altogether.

**Cleansing the Wound.**—The skin in the neighborhood of the wound must be well washed with soap-and-water and afterwards with water holding some germicide in solution, preferably the one to one-thousand solution of corrosive sublimate, thrown from a syringe or squeezed from a sponge or a pledget of antiseptic cotton. All foreign bodies—fragments of wood, glass, iron, etc.—and clots of blood must be carefully removed from the wound, either by picking them out with clean forceps or by washing them away with a stream of antiseptic fluid.

**Drainage.**—No part of the treatment can ever be more important than that which provides for the escape of the putrescible animal fluids discharged by the wound itself. Unless free outlet is left for the escape of these fluids (blood, serum, etc.), they accumulate in the wound, force its surfaces asunder, defeat repair, and increase the danger of septic absorption. Drainage may be attained by counter-openings, tents, setons, and the like, but is best accomplished by the insertion of perforated tubes of glass, decalcified bone, or the common black-rubber tubing, into the cavity of the wound, through its most dependent angle. The ends of the tubes should be allowed to project a short distance beyond the level of the skin and be held in place by aseptic safety-pins. Wounds of slight extent require only provision for the escape of the serum, and efficient drainage may be secured by the introduction of a few strands of carbolized silk, catgut, or horse-hair. Openings must always be cut in the first layer of the dressing, to free the projecting ends of the drain from pressure and consequent obstruction. No invariable rule can be laid down for the removal of the tubes; they should be withdrawn when there is no longer a discharge to be drained away,—usually not sooner than forty-eight hours; but it is better to allow them to remain longer than is absolutely necessary than to remove them too soon.

**Closure of the Wound.**—It is necessary for the perfect repair of a wound that its surfaces shall be placed in exact contact as soon as possible after its infliction. This object is effected by various measures,—

viz., sutures, adhesive plaster, compresses, and bandages. Simple incised wounds of limited extent usually require no other treatment than to arrest the bleeding and to bring the edges together and retain them by a few strips of adhesive plaster firmly drawn, supplemented by an absorbent compress and bandage. The divided parts adhere promptly, organization follows, and the surfaces are quickly joined together by a living bond of union.

In more extensive wounds the tendency of the divided parts to separate must be overcome by more effectual mechanical measures. It is not sufficient to retain the edges in contact; the deeper parts must be kept in apposition until organization can take place throughout the adhesive lymph which cements them together. This can be accomplished only by deep or "buried" and superficial sutures, aided, as already advised, by compresses and bandages.

**Sutures.**—The materials usually selected for sutures are silk, catgut, horse-hair, silver wire, or "silk-worm-gut." Pure well-annealed silver wire, as fine as possible (No. 28 to No. 30), possesses decided advantages over other sutures. It is strong, pliable, easily introduced, readily tightened by two or three turns, affords perfect support to the wound without constriction, is not absorbable, can be adjusted and readjusted in closing the wound, and if accidentally drawn too tight can readily be relaxed by un-twisting a turn or two or by cutting it between the first turn and the skin. When this is necessary, the constriction is at once relaxed, and the hook-like form of the suture still affords support to the edges of the wound. Sutures of silver may be left for an indefinite period without causing irritation. Horse-hair possesses similar advantages in a less degree. It is very easily introduced, but is a little difficult to tie, and is not strong enough for use in large wounds unless doubled. In wounds of the eyebrows and eyelids, and in plastic operations generally, it is an excellent suture. Silk sutures are easily introduced, and afford abundant support to the edges of the wound; but, unless thoroughly aseptic, they are irritating, and, if retained long, act as setons; if drawn tightly, they constrict and strangulate the edges and cut their way out. The very best quality of finely-twisted or braided silk must be selected, and may be rendered perfectly aseptic by boiling for thirty minutes in a five-per-cent. solution of pure carbolic acid. It may be kept for an indefinite period in the same solution, or in alcohol or carbolized oil (five per cent.). Catgut is a favorite suture with many surgeons, but really possesses no advantages over carbolized silk. If not properly prepared, it is unreliable, and, owing to the difficulty of sterilizing it perfectly, it is not free from the dangers of conveying infection. Volkmann reports a case of anthrax clearly traceable to its use. Silk-worm-gut makes an excellent suture, but is unabsorbable, and remains unchanged in the tissues for many months.

For the introduction of sutures, a straight needle, somewhat spear-pointed, and having a large *countersunk eye*, is the easiest to use and the most generally serviceable. In wounds of the cheeks and eyelids fine

curved needles are required to surmount the irregular contour of the surface.

Sutures are applied in various forms,—viz., the interrupted, the continuous, the twisted, and the quilled. The interrupted is the form most generally used, and for nearly all purposes is the best. The stitches are introduced at short intervals, so as to hold the edges of the wound together at many separate points. The first suture should be placed at the middle, the others alternately on one side or the other of this one until the wound is closed. Each suture must be carefully adjusted so as to hold the edges in exact contact, without inversion or eversion of the skin, and without constricting any portion of the tissues encircled by the loop. "One suture too tightly drawn may result in the death of the patient." (Esmarch.)

In deep wounds with division of muscles, as in the face, superficial sutures are not sufficient, and the advice of Mr. Keely should be followed, "to bring all the severed parts together by means of *buried* aseptic sutures." Chromicized catgut, carbolized silk or silk-worm-gut answers best for this purpose. This measure secures perfect contact of the entire surface of the wound, and more speedy union. As a general rule, strips of adhesive plaster should not be employed to support the sutures, and when resorted to should be always applied over aseptic compresses placed on each side of the wound. When applied directly to the skin they cause irritation, become foul, and interfere with drainage.

The continued suture is inserted in an uninterrupted seam, in the manner employed by glovers and seamstresses. It secures close apposition of the edges and is a good suture, but in large wounds must always be supplemented by very free drainage. This form of suture is especially applicable in wounds of the intestines, carbolized silk and chromicized catgut being the materials best suited for use.

The twisted suture is usually employed in plastic operations where support and moderate pressure are required, as in hare-lip and deep wounds of the face; it is clumsy at best, is extremely liable to become foul from absorbed discharges, and certainly has no advantages over the interrupted silver-wire suture.

**External Dressing.**—Having secured coaptation of the surfaces of the wound, and ascertained that the drainage is perfect by passing a stream of antiseptic fluid through the tubes, the external dressings must be applied. These dressings must be absorbent, germ-destructive, and so adjusted as to sterilize the air as it comes in contact with the discharges, to exert accurate and continuous pressure upon the sides of the wound, and to retain the affected part in a state of absolute rest. The wound is first rendered sterile by the means detailed; its discharges must be prevented from decomposing by being strained through an antiseptic covering, and the wound itself hermetically closed. The edges should first be well dusted with iodoform or powdered boric acid, so as to sterilize the discharge by bringing it in contact with a germicide as soon as it escapes. The impervious strip of pro-



tective material formerly deemed essential may be safely discarded, and its place supplied by a loose layer of moist iodoform or carbolized gauze, perforated for the ends of the drainage-tubes. External to this several layers of sublimate gauze must be arranged so as to exert a moderate degree of pressure and at the same time absorb the discharges from the drainage-tubes. A thick layer of borated cotton or of salicylic wool surrounds all, and is retained in position by an accurately and snugly applied roller bandage. If, in spite of deep or buried sutures, there be much tendency to separation of the deeper portions, aseptic pads should be applied on each side, and held in position by soft absorbent bandages. "This keeps the parts mechanically together, prevents nerve-tension, and promotes absorption." (Gamgee.)

No impervious material for the external dressing is required. When an extremity is involved, a light splint should be adjusted to it, and the part elevated, so as to prevent all motion in the damaged tissues, to secure absolute rest, and to avoid venous engorgement. This dressing ought not to be disturbed for several days, unless the wound becomes hot and painful, the child feverish and restless, and the dressing soiled with offensive discharges. Usually the dressing remains dry or but slightly soiled, the pulse and temperature are but little affected, and there is no pain. A wound in such a state should not be touched; nothing can be gained by removing the dressing and inspecting the parts, the child is only subjected to unnecessary pain, and the wound-surfaces are disturbed injuriously. The less it is interfered with, the more rapid and perfect will be the repair. When it becomes proper to remove the first dressing, it should be well moistened with an antiseptic lotion and cut layer by layer with scissors, and then gently lifted from the wound; the skin should be well washed, the drainage-tubes shortened or withdrawn, the stitches removed, and a new dressing in every way similar to the first applied.

If the surgeon does not have at his command all the elegant and expensive appliances for the antiseptic dressing of a wound, he will be obliged to improvise them from whatever crude materials he can find within reach. Strips or shreds of clean old linen or muslin are soft, pliable, and chemically pure, and will absorb fluids rapidly. Such materials placed for a few minutes in some hot antiseptic solution—as the solution of corrosive sublimate, one part to one thousand (made by dissolving seven and a half grains of the sublimate with an equal quantity of common salt in one pint of water), tincture of iodine in water, one to one hundred and fifty, carbolic acid in water, one to twenty, or a saturated solution of boric acid in hot water—will be transformed into a very perfect antiseptic dressing, from which pads, compresses, and bandages can readily be made. Silk, linen, or cotton thread similarly treated is rendered perfectly innocuous, and affords material for sutures and ligatures which is just as reliable as the most expensive that can be purchased from the dealers. A skein of this thread inserted into the wound, in the absence of the perforated tubes, secures good drainage. The wound, properly cleansed with a portion of the

same solution that has been used to render the dressing antiseptic, may now be closed and dressed with these improvised materials, and repair will go on just as rapidly and perfectly as it does under the most complicated dressings.

**After-Treatment.**—If properly applied, the first dressing is very often the only one required; the exposed surfaces of the wound unite without febrile excitement or systemic disturbance and without sufficient discharge to soil the dressing. The union, however, is not yet firm, and compresses and bandages will be required for several days to give support to the newly-formed tissues. Removal of the sutures will depend upon the progress of repair; they should be withdrawn as soon as possible,—usually in from forty-eight to seventy-two hours, but in large wounds, with tendency of the edges to separate, they should not be disturbed for several days; time must be allowed for deep cicatrization to occur before their support can be dispensed with. If any of them are too tightly drawn, or show a tendency to cut out, they should be removed at once, as they only cause irritation and endanger repair in other parts of the wound. They are best removed by grasping them gently at the twist or knot with a pair of forceps, dividing them with scissors, and withdrawing them carefully, so as not to put any strain upon the wound. Metallic sutures must be cut close to the skin, and the hook-shaped ends straightened before attempting to remove them. Withdrawal of the sutures must always be followed by the support of compresses and bandages, and these must be employed until everything has consolidated.

Ordinarily very little treatment is required beyond the occasional adjustment of dressings and bandages, to keep the parts at rest until nature completes the reparative process. If, however, a portion of the wound fails to unite or breaks down before union is perfect, additional care must be exerted to keep the parts aseptic until healing by granulation occurs. If the parts become hot and painful and the child feverish, the dressing must be removed, the sutures taken out, and the source of irritation sought for and removed. If discharges have been retained, provision must be made for their escape, and it may be proper to substitute cool or antiseptic irrigation for the dry dressing heretofore employed.

Attention to the hygienic surroundings of the child will also be necessary. The diet should be bland, nutritious, and easily digested; broths, milk, etc., should be given generously from the first, and later may be reinforced by wine and more substantial food. The child should be kept, if possible, in an airy, well-lighted, and well-ventilated upper room; the bed, bedclothing, and garments worn must be clean, and should be cleansed frequently. It is true that children living on impure and insufficient food, and breathing a foul animalized atmosphere, recover well from severe injuries; but it is equally true that they do infinitely better when surrounded by proper hygienic conditions.

## CONTUSED AND LACERATED WOUNDS.

A contused wound is inflicted by a blow from a blunt instrument or missile, as a club or stone, or the toe or heel of a heavy boot, or is caused by a fall in which the brow or face strikes against a curbstone. The edges of the wound are inverted, abraded, and greatly ecchymosed, and the vitality of the tissues is seriously impaired, often far beyond the apparent limits of the injury.

Lacerated wounds present many of the features of contused wounds, and the two forms of injury may properly be considered together. In them the "tissues are both bruised and torn," and the edges are inverted, irregular, and often darkly discolored. The skin is torn from the underlying fascia, and hangs limp and loose, having lost its elasticity by the stretching to which it has been subjected; in severe injuries the underlying fascia is torn to shreds, and the muscles are disintegrated and reduced to a pulp. Such injuries are commonly caused by machinery, by railway accidents, or by the passage of a carriage- or wagon-wheel over the body. In adults they are very often followed by more or less sloughing of the damaged tissues. In childhood this result is scarcely to be feared unless the entire vascular and nervous supply of the part has been destroyed.

**Hemorrhage.**—The hemorrhage caused by contused or lacerated wounds is usually trifling, except when large arterial and venous trunks are severed. Even then there is no active hemorrhage beyond the momentary gush of blood which immediately follows the accident. I have several times seen the torn end of the brachial artery so effectually closed by a clot that not a drop of blood escaped from it, although the arm had been torn from the body just below the shoulder and the artery hung loose amid the mangled tissues of the stump. The violence which severs the vessels lacerates and contuses the internal and middle tunics, and thus favors the rapid formation of a clot; the clot is temporary, but it effectually prevents any further bleeding. A troublesome oozing, however, not unfrequently comes from the surface of the wound, and, while the quantity of blood lost may not be great, its continued escape increases and prolongs the shock.

**Pain.**—The pain of contused and lacerated wounds is not usually severe; the tissues are benumbed by the bruising force of the accident, and a child suffering from a crush of a limb severe enough to necessitate amputation rarely makes much outcry if the injured parts are not disturbed. Laceration and contusion of the toes and fingers are excessively painful, however, and such injuries are not unfrequently followed by tetanus.

The constitutional effects may be so mild as to merit little attention, or so severe as to imperil the life of the child.

**Shock.**—The shock which follows severe wounds of this character is always very profound, and death may result from syncope or asthenia. When reaction occurs it is usually prompt, and is sometimes attended by

undue febrile excitement, with mild nocturnal delirium. The wound during this period becomes painful, hot, and swollen, and a copious sanious discharge escapes from it. The surrounding skin becomes tumid, and sometimes is covered by bullæ filled with a blood-stained serum. This period is usually short, and is succeeded by a rapid subsidence of all alarming symptoms; the pulse and temperature fall, the skin becomes cool and moist, and the wound assumes a healthy appearance. If proper care be observed in the primary dressing, this febrile state can in great measure be averted.

**Complications.**—Since the structures in the vicinity of the wound are always injured, and sometimes so seriously that their vitality cannot be restored, necrosis results, and sloughing of the damaged parts must precede repair. In many cases of extensive injury the disintegrated textures perish over a wide area by a localized gangrene. The dead skin, at first dark purple in color, becomes ashy gray or brown; an active cell-infiltration and the development of young granulation-tissue follows in the borders of the living skin; and the dead tissues separate slowly from the living, and leave a granulating surface underneath. Unless perfect antiseptics is maintained, suppuration, often dangerous and exhausting, is very liable to occur. The danger of septic infection is, fortunately, not great in childhood; but it is, nevertheless, important to protect the wound from all sources of contamination and to keep it pure. Putrefaction of the discharges, and the consequent formation of irritating and poisonous alkaloidal products of decomposition in the wound, are prevented by this care, and physiological repair by granulation goes on uninterruptedly.

#### TREATMENT.

The treatment of contused and lacerated wounds differs from that adapted to the simpler forms. The tissues have been subjected to greater violence, a wider area has been severely damaged, and important textural changes, limited necrosis, and sloughing are often unavoidable. Union by granulation is the only method of repair usually attainable, and the prevention of septic infection becomes of paramount importance. But in superficial wounds, whether contused or lacerated, especially in wounds of the scalp or face, healing by first intention is possible, and an effort should always be made to secure it.

The indications for treatment, accordingly, are not only to stop bleeding, to cleanse, close, and drain the wound, and to apply external dressings, but also to preserve the vitality of all tissues not hopelessly damaged, to hasten the separation of disintegrated and dead tissues from the living, and to prevent the occurrence of decomposition and suppuration by adherence to a rigid antiseptics.

The hemorrhage having been controlled by the measures detailed under Incised Wounds, and the skin carefully washed with soap-and-water and afterwards with some antiseptic solution, the wound should be thoroughly cleansed and freed from all foreign bodies.

Great care must be taken to bring the antiseptic fluids in contact with the whole surface, by inserting the nozzle of the syringe or irrigator underneath the flaps of loose integument; but the utmost gentleness must be observed in handling the damaged tissues.

The surgeon should hesitate to clip any loose shreds of skin not absolutely detached from the wound: it is better practice to cleanse them carefully and replace them as nearly as possible in their former position. Vitality is sometimes preserved in very doubtful-looking tissues, with a corresponding decrease in the size of the scar. In wounds of the hand this precaution should be strictly observed: extensive and hopeless-looking crushes of the hand and fingers are sometimes repaired in a remarkably perfect manner, and, no matter how unshapely and imperfect the condition of the member may be, no artificial substitute can ever equal it in value.

**Closure of the Wound.**—If the wound be slight or situated in the scalp or face, its edges must now be united by a few points of interrupted suture, a protective dressing applied, and the wound treated as an incised wound. Where the injury has involved a wider extent of tissue, with laceration of the skin, fascia, and muscles, no attempt should be made to close the wound tightly. A few points of interrupted suture may be inserted to lessen the separation of the skin and to give temporary support to the torn muscles, but they must not be drawn tightly nor placed so close together as to interfere with free drainage. As a general rule, adhesive plaster should be avoided.

**Drainage.**—The introduction of drainage-tubes for the discharge of the wound-secretions will generally be required, and if necessary counter-openings should be made at the most dependent part. In extensive wounds the drainage-tubes should be of large size, not less than one-third of an inch in diameter.

**External Dressing.**—When the wound has been thoroughly cleansed with the antiseptic lotion, and sutures and drainage-tubes inserted at the points deemed necessary, it is ready for the external dressing. The whole surface should now be dusted with powdered iodoform and covered by a few layers of iodoform or carbolized gauze through which openings have been cut for the ends of the drainage-tubes. Several layers of moist sublimate gauze are now applied to cover the entire area of the wound and the skin for some distance beyond its margins. A thick layer of borated cotton or salicylated wool is placed outside of all and held in position by a carefully-adjusted roller bandage. The utmost care must be observed to avoid constriction of the wounded parts, especially in the extremities, lest the feeble circulation be still further impeded and gangrene be induced. The dressing must be so adjusted as to support and protect the wound and keep it at perfect rest. The moderate elastic compression afforded by the external layer of cotton wool is highly beneficial by retaining its surfaces in contact; but beyond this all pressure and all tight bandaging are mischievous and injurious.

After the dressing is completed the wounded extremity should be slightly elevated by placing it upon a pillow, and dry warmth by hot bricks or bottles of hot water will be required when the vitality of the part is low. A light splint is useful by affording additional support. No further interference will be needed until after a period of forty-eight hours, unless the dressings become foul with the discharges, the child be restless and sick, the wound painful, or the temperature elevated above 101° F. Usually at the end of forty-eight hours the first dressing should be removed and the wound dressed again. If its appearance is satisfactory and there is no sign of suppuration or extensive death of tissue, the sutures may generally be removed, the drainage-tubes should be examined, readjusted, or removed, the surface of the wound again lightly dusted with iodoform, and the new dressing applied at once with the same rigid antiseptic care as was observed in the primary dressing. It should not again be disturbed for several days, unless febrile symptoms arise or the dressing becomes foul. Frequent dressings certainly retard the healing process.

If, however, the wound is hot and painful, its edges swollen and everted, its surface covered with ashy-gray sloughs, the discharge profuse and ichorous, and the child feverish and sick, the wound is no longer aseptic, it is practically a phlegmon, and repair without more or less extensive suppuration and sloughing becomes impossible, unless some other and more efficient method of treatment is employed. Warmth and moisture are now required. A water dressing by fomentations or by continuous irrigation with cool or tepid antiseptic solutions must be substituted for the dry antiseptic dressing. The advantages of this change consist in the prevention of decomposition of the necrosed parts, the continuous removal of irritating discharges, and the more speedy separation of the dead tissues; primary adhesion has failed, and it becomes necessary to "encourage the process of sloughing in order to bring into operation that of healing by granulation." (Gant.)

In those very severe wounds which occasionally involve the extremities and in which no hope of repair without great loss of substance can be entertained, the *continuous local bath* by immersion of the wounded part in a vessel filled with tepid water rendered antiseptic by the addition of corrosive sublimate (one to five thousand), or carbolic, boric, or salicylic acid, possesses many advantages over other methods of treatment.

The apparatus required for the continuous local bath is a box or tub of tin or zinc, which can be placed at the foot or side of the bed by cutting away one or more of the slats. The outer edges of this tub are provided with hooks, from which a sling of muslin is suspended across the cavity of the tub, and upon this sling the injured extremity must rest while immersed in the antiseptic solution. The temperature of the solution may be kept up by means of a spirit-lamp placed underneath the tub. The continuous bath should not be employed, however, immediately after the injury. The recently-injured tissues commonly require the influence of dry heat rather than of moist, and hence they should first receive the benefit of a dry anti-

septic dressing, with dry heat and moderate elevation of the limb, until the structures not hopelessly damaged have recovered their vitality and some degree of cellular proliferation is present in the wound; otherwise the little life remaining may be destroyed through vascular disturbances induced by the too early application of an unusual degree of moisture. It is a method of great value in cases of deep sloughing and progressive suppuration with burrowing of pus beneath the muscles and fascia. The limb is placed in water at a temperature regulated by the sensations of the patient, and must be kept in this bath for a week or longer, until all the sloughs have separated. The water in this bath must be kept fresh and pure by frequent changes, and its temperature may be elevated gradually, so as to hasten the separation of the sloughs. The limb usually swells enormously and becomes discolored from imbibition of fluid, and the granulations are blue-looking and œdematous; but this discoloration and œdema disappear when it is removed from the bath, the granulations soon regain their natural appearance, and cicatrization is completed in the same way as in ordinary granulating wounds.

Occasionally, despite the utmost care, the granulations become pale and unhealthy or florid and exuberant, and cicatrization ceases. Wounds in this condition require the application of stimulating lotions to rouse the feeble granulations to a healthy activity or to repress the inordinate vascularity which delays the completion of the healing process. Weak astringent lotions, as the solution of sulphate or chloride of zinc, or dilute nitric acid, become valuable adjuncts to treatment: where a more positive impression is desired, the solid nitrate of silver brushed lightly over the surface of the wound will be useful in hastening "desiccation." The oxide-of-zinc ointment, rendered aseptic by the addition of boric or carbolic acid, is sometimes useful in hastening cicatrization; but, as a rule, salves and ointments may be very generally discarded.

---

## PUNCTURED WOUNDS.

A punctured wound is an injury inflicted by a sharp- or dull-pointed instrument or body, as a nail, a fragment of iron, of wood, or of bone, a thorn, the tooth of an animal, or the slender blade of a knife. Its depth far exceeds the extent of the external injury or visible lesion, and its character will vary with the form and nature of the vulnerating body. A puncture with the sharp blade of a knife causes a deep incised wound, while that caused by a nail or a thorn is both contused and lacerated.

Punctured wounds acquire importance from their depth, their locality, and the nature of the structures injured. If the skin and subcutaneous fat alone are punctured by a clean instrument, no serious consequences are likely to follow, and the wound will heal kindly and without suppuration

under a simple antiseptic dressing. If, however, the weapon penetrates a joint or wounds a large arterial trunk, the consequences will be of a very serious character,—a violent traumatic synovitis in the one case, a fatal hemorrhage or a diffused traumatic aneurism in the other.

But if the wound is caused by a rough-pointed instrument, as when a rusty nail or a fragment of wood or of iron penetrates the skin, muscles, and fascia, it is deep, lacerated, and liable to become poisoned, either by the puncturing body or by foreign or septic matter conveyed from the skin to the bottom of the wound.

Drainage of such an injury is very difficult to secure, and decomposition of the retained extravasation, with violent and destructive inflammation and widely-diffused suppuration, is almost certain to follow. Accidents of this character involving the palms of the hands or the soles of the feet are always liable to be followed by most serious consequences, among which tetanus and general blood-infection are not rare. Such injuries require prompt and careful treatment. If the puncture has been inflicted by a blunt body, as a rusty nail, the wound should at once be freely incised, so as to give abundant room for the escape of blood and extravasated fluids, its entire surface should be thoroughly cleansed and irrigated by some efficient antiseptic fluid, as the corrosive-sublimate solution, one to five hundred, a drainage-tube inserted, and an antiseptic dressing applied. Where the wound is so located as to permit it, the part should be immersed in the antiseptic for an hour or two, and then cauterized with pure carbolic acid before the application of the primary dressing.

In treating bites of animals, the method pursued at Bellevue Hospital, New York, is to immerse the bitten part in a hot solution of bichloride of mercury, one to two hundred, for thirty minutes, then to cauterize the wound freely with fuming nitric acid, and afterwards to dress it antiseptically.

If the wound has been neglected, it must be incised freely upon the first evidence of inflammation in the part, and a careful search made for foreign bodies, while counter-openings must also be made if needed to secure free drainage.

Wounds involving joints require a rigid antiseptics, with extension and fixation of the joints, and the external application of cold by ice-bags, cold compresses, and the like.

When a large artery has been punctured, clearly the safest practice is to enlarge the external wound and secure the vessel by ligatures applied to both proximal and distal sides of the puncture, and then to divide the vessel entirely between the ligatures. Such wounds are always attended by danger, and require energetic treatment from the moment of accident. It is useless to temporize with them: valuable time is wasted and the life of the patient may be sacrificed by hesitating. No punctured wound should ever be regarded as trivial, and certainly no other form of wound requires more careful management.



## POISONED WOUNDS.

When certain specific emanations from living or dead animal bodies are introduced into wounds, whatever their form may be, they acquire new and deadly qualities, and the traumatism sinks into insignificance in the presence of a poison "acting upon the blood, contaminating the constitution, and developing distinct and special symptoms." (Poland.)

The sources of wound-contamination are varied, but may be classified as follows: first, the poisonous secretions from healthy but venomous reptiles or insects (bites of serpents, stings of bees, etc.); second, the discharges from diseased animals (glanders, hydrophobia, etc.); third, fluids from recently-dead animal bodies (dissection-wounds, etc.). The poison (or poisons, for they are probably numerous) from dead animal bodies undoubtedly belong to the alkaloidal products of decomposition, the *ptomaines* or *cadaveric alkaloids*, which in their action upon the animal economy resemble several of the poisonous vegetable alkaloids. That present in the venom of reptiles and poisonous insects probably belongs to the same class of animal poisons,—the poisonous agent being a chemical product, incapable of multiplying in the blood, requiring no period of incubation, not transmissible to other persons, and exerting its toxic power in proportion to the amount absorbed. On the other hand, inoculation by the discharge from diseased animals—from a dog suffering with hydrophobia, or from a horse afflicted with glanders—depends upon the introduction of specific germs into the bite, or at least a virus, which contaminates not only the wound, but also the blood of the individual. The disease acquired by inoculation may be transmitted from one individual to another, and after death the blood teems with micro-organisms. The smallest quantity inoculated is sufficient to produce all the characteristic effects, but the outbreak does not occur until after a period of incubation or quiescence, during which the germs multiply and acquire destructive energy.

## POISONED WOUNDS RESULTING FROM STINGS OF INSECTS, BITES OF SERPENTS, ETC.

The stings of insects—bees, wasps, and the like—although very painful, usually require very little attention. The pain is promptly allayed by bathing the part with a solution of soda or ammonia, or by covering it with olive oil, and the swelling disappears in a few hours. If, however, a young child is stung simultaneously in many places, as sometimes happens during the swarming of bees, the severity of the pain and the quantity of poison introduced into the blood produce an alarming degree of constitutional disturbance, and death occasionally results. Stings involving the tongue and fauces are followed by great swelling of the parts, and death may speedily follow from œdema of the glottis. Such cases are best treated by alkaline gargles and washes, but, if symptoms of suffocation occur,

free scarification of the glottis becomes necessary, and tracheotomy may be demanded to save life.

The sting which conveys the poison is a slender, barbed, needle-like weapon, which is often left in the skin, and, as its presence is a source of irritation, it should be grasped with fine forceps and removed; afterwards the part should be bathed with a solution of soda or carbolized oil. The alarming depression which occasionally follows multiple stings is best combated by diffusible stimulants, brandy, ammonia, etc.

In the southern and southwestern parts of the United States, the wounds inflicted by the mandible of the tarantula and the centipede and the stings of the scorpion are said to be followed by serious local inflammation and sometimes by violent constitutional disturbance. Dr. Linceium, of Texas, reports the case of a child four years old who died in six hours after the bite of a very large centipede. Dr. Thomas A. Pope, also of Texas, reports a death from a tarantula-bite; the man was bitten in the neck, and died from asphyxia due to the swelling.<sup>1</sup> In southern Italy and in the Orient death is said occasionally to follow the sting of the scorpion. The treatment consists in neutralizing the local effects of the poison by alkaline washes and in combating the constitutional depression by diffusible stimulants.

The bites of poisonous serpents constitute a very serious class of injuries; the bites of the cobra, duboia, and other reptiles in India are rapidly followed by death. In the United States the only poisonous serpents are the rattlesnake, the copperhead, and the moccasin-snake, the latter found only in the Gulf States. The bites of the rattlesnake and the copperhead are very similar in their effects, both being followed by an alarming train of symptoms, which not uncommonly end in death.

The venom of all serpents is secreted by a pair of glands situated on either side of the upper jaw below the eyes, which communicate with a groove or tube in the fangs. The fangs are movable, very sharp, grooved or channelled for the transmission of the venom, and in their quiescent state lie in folds of the mucous membrane lining the roof of the mouth. When the serpent strikes, the muscles attached to the base of the fangs contract and throw them into an erect position, and compress the glands or poison-sacs simultaneously, injecting the venom along the grooves when the fangs are driven into the flesh of the bitten animal.

The venom is a yellowish-green, albuminous fluid, acid in reaction, with a specific gravity of 1.044, and, according to Mitchell and Reichert, contains three proteid substances,—venom-globulin, venom-peptone, and venom-albumen.<sup>2</sup> It is not affected by heat, cold, acids, alkalis, or decomposition, may be taken into the stomach with impunity, and does not render the flesh of animals destroyed by it unfit for food.

**Symptoms.**—The wounds inflicted by all venomous serpents are

---

<sup>1</sup> Wyeth, Text-Book on Surgery, p. 78.

<sup>2</sup> Philadelphia Medical News, 1883; Lancet, July 21, 1883.

speedily followed by pain of an intense character, and by rapid swelling and discoloration of the parts. The swelling extends rapidly towards the trunk; the skin is livid, mottled, and sometimes vesicated; in severe cases the subcutaneous connective tissue is infiltrated with an ichorous, offensive fluid like that of gangrene, and the wound itself may become gangrenous.

Severe constitutional symptoms, manifested by intense shock, tremor, dizziness, nausea, and vomiting, with feeble, irregular heart-action, appear very early. In fatal cases death may occur in a few hours or may be delayed for several days, and may result from either heart-failure or coma, or may be preceded by the typhoid state or by symptoms of a septic character, with delirium, convulsions, and coma. The condition of the reptile at the time the bite is inflicted, the age and health of the person bitten, and the quantity of venom injected into the tissues, undoubtedly influence the result. The bite of a full-grown, active serpent that has not recently bitten any other animal will be followed almost instantly by extremely violent symptoms even in a vigorous person of adult age, and possibly by death; whereas a similar bite inflicted after the serpent has bitten several animals will be followed by comparatively mild symptoms. The poison of all venomous serpents—except possibly that of the cobra, whose victims die too promptly to permit such a change—destroys the coagulability of the blood and disintegrates its red corpuscles; hence the chief post-mortem appearances are a fluid condition of the blood, and extravasations and sanguinolent effusions into the serous cavities.

**Treatment.**—As there seems to be no absolutely reliable antidote for the venom, the treatment of serpent-bites must aim to prevent the entrance of the poison into the blood, and to overcome the depression of all the vital functions which follows its absorption even in small quantity. The first object is best accomplished by immediately applying a very firmly drawn ligature to the bitten extremity some distance above the wound, so as to stop all circulation in the part, and then by encouraging the wound to bleed by freely incising it and employing active suction with the lips, or preferably with a cupping-glass, if one can be obtained, for there is always danger that the venom may poison an unobserved abrasion on the lips. The wound must then be washed freely with diluted aqua ammoniæ or diluted tincture of iodine. Recently a five-per-cent. solution of potassium permanganate in water is recommended by Dr. Lacerda Filho<sup>1</sup> and by Mr. V. Richards,<sup>2</sup> either locally applied to the wound or injected underneath the contiguous skin. It is asserted to have effectually neutralized the cobra-poison. If the bite is on the face, cauterization with a hot iron is recommended before using the permanganate lotion, and certainly will be effectual.

If the patient survives, more or less sloughing of the skin and sub-

---

<sup>1</sup> Medical Times and Gazette, August 27, 1881.

<sup>2</sup> Lancet, September 15, 1883.

cutaneous connective tissue may be expected, and this should be favored by free incisions and by warm detergent irrigations. Constitutional depression is best met by moderate doses of morphine to relieve the pain (and terror), and by the free administration of alcoholic stimulants in the form of whiskey or brandy. These should be given, not in moderate but in very large doses, until signs of intoxication are unmistakable; after this the patient should be kept mildly under the influence of the stimulant until danger is past. The quantity of whiskey or brandy required to produce intoxication in men suffering from the bite of the rattlesnake is stated to be enormous; and the late Surgeon G. E. Cooper, U.S.A.,<sup>1</sup> reports one instance in which a bottle of brandy and a bottle and a half of whiskey were drunk before any effects were observed. It is asserted that as soon as intoxication occurs the muscular tremors stop in the bitten limb and the swelling ceases. Children are usually very susceptible to alcohol, and care must be observed in its use, lest the depression of large doses intensify the effects of the animal poison.

#### WOUNDS POISONED BY CONTACT WITH THE SECRETIONS FROM DISEASED ANIMALS.

**HYDROPHOBIA (RABIES CANINA, LYSSA, HUNDSWUTH).**—This fearful malady originating in the canine race is communicable to man and to all warm-blooded animals by inoculation with a specific virus present in the saliva and blood of the rabid animal. The common source of inoculation is the bite of an infected dog, but the bite of the rabid wolf, fox, or badger is no less dangerous, and it is stated by General Dodge, U.S.A.,<sup>2</sup> that in the valley of the Republican River, Colorado, the bite of the skunk is almost invariably followed by hydrophobia. Rabies is not transmissible from man to man, nor from man to the dog. Pasteur has produced rabies in healthy animals by inoculating them with the cerebro-spinal fluid and brain-substance of animals recently dead of the malady.

Inoculation may occur through trifling abrasions on the hands or face if in any way brought in contact with the saliva of a rabid animal; even the bite of an apparently healthy dog has been followed by rabies. The virus is also communicable by the blood of a rabid animal. A student, while examining the body of a dog that had died from rabies, accidentally inoculated himself by wounding his finger, and died six weeks afterwards from hydrophobia. (Hertwig, Van Buren.)

Fortunately, about one-half of the persons bitten by rabid animals escape infection; but bites upon unprotected portions of the body are extremely liable to be contaminated. Of those bitten in the face ninety per cent., of those bitten on the hands fifty-three per cent., and of those bitten where the part was protected by clothing twenty-four per cent., were

<sup>1</sup> Smith's Surgery, vol. i. p. 445.

<sup>2</sup> The Plains of the Great West.

infected. (Anderson.) The excessive frequency of inoculation in bites of the face is largely due to the vascularity of the tissues and to the activity of absorption.

**Symptoms.**—Inoculation is followed by a period of incubation which varies greatly in length in different cases. The period in the human subject ranges from two weeks to eight months; the most accurate observations seem to fix about forty days as the average period of latency. No constant symptoms are present during this process of incubation. The scar left by the bite sometimes becomes irritable and is the seat of various neuralgic disturbances, while the lymphatic glands in connection with it swell. Small papules beneath the tongue, occurring from the third to the ninth day after the bite, are noted by Anderson.

The onset of the disease is marked by rather vague symptoms. The patient's disposition changes; he becomes gloomy, irritable, and despondent,—and this feature is marked even in young children; the face wears an expression of anxiety and suffering; the heart-action is frequent and irregular; chills succeeded by fever occur at short intervals, and there are generally evidences of disorder of the central nervous system. This period, the "melancholic stage," is of variable duration,—from a few hours to several days,—and is followed by or imperceptibly runs into the active stage, stage of excitement, or "convulsive stage," which is usually ushered in by some stiffness of the neck, twitching of the muscles of the face, pain in the region of the fauces and glottis, and slightly-spasmodic respiration. The tongue is dry, and efforts to quench thirst give rise to violent spasms of the muscles of deglutition and respiration. Mental disorder, marked by delirium, spectral and hysterical illusions, and paroxysms of violent maniacal excitement with active rabid manifestations, are present, but are generally succeeded by lucid intervals. The difficulty of swallowing increases rapidly, and the effort induces fearful spasms of the muscles of deglutition and respiration. Hyperæsthesia increases coincidently with exaggerated reflex excitability, and a current of air, a flash of light, or the jarring of a door is sufficient to excite a violent recurrence of the spasms. The voice becomes weak and husky, "like the bark of a dog;" a profuse viscid salivary secretion, which cannot be swallowed, is expectorated in every direction; præcordial pain, vomiting, excessive thirst, and dysuria add to the general suffering. Albumen and sugar are occasionally present in the urine. The spasms increase in frequency but diminish in force, and the patient either dies asphyxiated in a convulsion, or drifts into the third or "paralytic stage," when, with entire loss of muscular power, he lies utterly prostrate and helpless, but often entirely conscious and rational, despite the exhaustion, until death ends his suffering, an event which usually occurs in from two to five days in adults, while children generally succumb in less than twenty-four hours.

**Diagnosis.**—There can be little doubt that many nervous disorders, and especially hysterical manifestations, are mistaken for true hydrophobia.

It is also altogether probable that many of the deaths reported from this disorder have been due to other and less serious maladies, and that the influence of terror, acting upon weak and diseased nervous systems, has many times served to intensify conditions which were otherwise not necessarily fatal. That true human rabies is an exceedingly rare disease cannot be denied. It is evident, therefore, that a correct diagnosis is a matter of extreme importance.

The diseases from which human rabies must be distinguished are tetanus and hysterical convulsions. The absence of a recent wound, the long period of incubation, the fact that spasms are *clonic* and involve the muscles of deglutition and respiration, and not those of mastication, the absence of general muscular rigidity or spasm, and the presence of spectral illusions and maniacal delirium, should very clearly distinguish rabies from tetanus. From hysteria the disease may usually be distinguished by the age and sex of the patient, the suddenness of the onset, the violence of unimportant symptoms, and the absence of symptoms which most certainly imperil life.

**Pathology.**—The nature of the virus which induces rabies has not yet been ascertained; but it seems probable that it is of bacterial origin, and that the specific germs, after being introduced into the tissues of a healthy animal, remain dormant during a period of incubation, and then manifest their presence by inflammatory changes at the seat of inoculation, together with the formation of some specific and deadly but unisolated ptomaine, which entering the blood exerts a poisonous and destructive influence upon the central nervous system.

**Morbid Anatomy.**—The post-mortem appearances point to the action of some blood-poison,—viz., fluidity of the blood; ecchymotic spots beneath the pleura, pericardium, and membranes of the brain and spinal cord, with minute hemorrhagic infarctions of the smaller vessels and miliary abscesses in the gray matter; organic changes in the ganglion-cells of the ninth, tenth, and eleventh cranial nerves; and copious infiltration of leucocytes into the perivascular spaces of the cerebral cortex and the medulla oblongata. Cheadle has discovered rod-like bodies resembling bacteria in the extravasations of blood in the same region. Klebs has found highly-refractive granular corpuscles arranged in bands or stellate groups in the lymphatic and submaxillary glands; and Gibier has recently claimed the discovery of a micro-organism constantly present in pigeons inoculated with the virus of rabies. Thus far, however, the discovery of a specific microbe in rabies has not been confirmed.

**Treatment.**—The fact that there is no remedy or method of treatment which either modifies the progress of the disease or limits its fatal effects renders the importance of a perfect prophylaxis self-evident.

Prophylactic measures are directed, first, to the destruction of the virus immediately after its introduction into the tissues and while it is yet localized in the wound, and, secondly, to efforts to neutralize the virulence of

the poison before it can enter the system, or rather to render the bitten person unsusceptible to its effects by inoculating him with an attenuated rabic virus during the last stages of its incubation, after the method of Pasiour.

The first object is best attained by promptly encircling the limb at a point some distance above the bite with a tightly-drawn ligature, to arrest the circulation and prevent absorption. The wound should next be vigorously sucked with the lips, if there are no abrasions upon them, or by a cupping-glass, and as soon as possible should be bathed or immersed in a hot solution of corrosive sublimate, one to one hundred, for half an hour, and then cauterized freely with a red-hot iron, fuming nitric acid, or pure undiluted carbolic acid: nitrate of silver is too shallow a caustic to be of any value. The ligature must be removed as soon as the cauterization is completed. As the pain of the cauterization is intense, an anæsthetic will usually be required; after this the part must be enveloped in an antiseptic dressing and kept at rest until healing is completed. When done with a free hand, this treatment is more reliable than excision of the part, though excision should be resorted to if the wound has already healed.

Dogs are very filthy animals at best, feeding constantly upon all sorts of putrid matter, and their teeth are liable to be charged with poisons but little less deadly than that of rabies; their bites cause not only punctured and lacerated but also poisoned wounds, and for these reasons all bites inflicted by a dog, whether the animal be suspected of rabies or not, should be subjected to thorough cleansing and cauterization. The bitten person should avoid the use of all intoxicants.

The second form of prophylaxis, by inoculation with attenuated rabic virus, has been extensively practised in France and Russia under the direction of Pasteur and his pupils, with results which are claimed to be highly satisfactory. Grancher asserts that the mortality in persons bitten by mad dogs was reduced in Paris in 1888 to seventy-seven hundredths of one per cent. by inoculation, against fifteen and nine-tenths per cent. in bitten persons who were not submitted to this treatment.<sup>1</sup> The attenuated virus is obtained from the dried spinal cords of rabbits dead of rabies artificially produced by inoculation from dogs known to be rabid, and is introduced in the form of emulsion in water by means of a Pravaz syringe.

The efficacy of this treatment is denied by very competent authority, and it is asserted that death has resulted from its employment. The question of its value may therefore be regarded as still unsettled, although the weight of evidence seems to be in its favor. Certainly cauterization of the wound should not be neglected even if the protective inoculations are employed. It would also seem rational to use some method of internal medication during the incubative stage, similar to that employed in syphilis,

---

<sup>1</sup> Medical News, December, 1888.

in the hope of either eliminating the poison or rendering it inert in the tissues.

The symptomatic or curative treatment is very unsatisfactory. The most that can be done is to relieve the sufferings of the patient. As the disease is rapidly fatal, there is little time for the employment of remedies. Owing to the difficulty or impossibility of swallowing, all nourishment should be administered by the rectum, and hypodermic injection is the only practicable method of medication. The remedies which possess any value are few. Chloroform, chloral, morphine, atropine, curare, and pilocarpine are probably the most reliable. Three recoveries are claimed (by Offenburg, Polli, and Watson) to have followed the use of curare. The dose in one case was two-thirds of a grain and was repeated at intervals as the effects passed off. In the second case three and a half grains were given in five and a half hours to a child of twelve years, and in the third it was given in doses gradually increased from one-sixteenth to one-half grain every three hours. The drug arrests the rabic spasms by paralyzing the motor nerves, and therefore requires caution in its use. The patient should be kept in a dark, quiet, well-ventilated room, and be protected from draughts of cold air, noise, and all sources of excitement. Nourishing broths, stimulants, and liquids must be given by enemata to sustain the patient's strength.

**GLANDERS.**—Glanders is a disease occasionally prevalent among horses, and is sometimes communicated to man by inoculation or by absorption of the virus through the mucous membranes. It is due to a specific micro-organism, the bacillus mallei, first isolated and cultivated by Schütz and Loeffler in 1882, though previously seen by Christatt and Keiner and by Bouehard, Capitan, and Charrin. It is a small, rod-like bacillus, resembling the bacillus of tubercle. It may be cultivated in solid blood-serum, potato, beef peptone, and agar-agar jelly: the cultures retain their vitality for a year.

In horses the disease first appears upon the nasal mucous membrane, in the form of nodules or of small, deep, excavated ulcers, surrounded by marked cellular infiltration. The submaxillary glands become involved early, and the disease spreads by metastasis to other organs.

In man the inoculation with the virus of glanders is followed in about eight days by chills and general febrile excitement, and by the appearance of nodules in the mucous membrane of the nostrils; deep, foul ulcers soon after appear from rupture of the nodules, and the nostrils discharge a thin, offensive, sanious pus. The submaxillary and cervical glands become involved, the face is swollen, the nodules break down into deep, excavated ulcers which appear upon the skin, the mucous membranes of the air-passages and of the digestive tract are similarly attacked, and vomiting and diarrhœa are present. The febrile condition assumes an adynamic form, with low muttering delirium, extreme prostration, and evidences of general septic infection.

The diagnosis is difficult, and in the very early stages almost impossible



without some antecedent history. The disease has been mistaken for rheumatism, for varicella, and for small-pox, and in its later stages for pyæmia and typhus fever.

The treatment should be supporting and mildly stimulating. If a point of infection can be discovered, it should at once be destroyed with fuming nitric acid. Internally quinine in large doses, three to five grains every six hours to a child of five years, with the mineral acids or the tincture of the chloride of iron, should be administered. The diet should be nutritious, and moderate stimulation by wine, whiskey, or porter will be valuable. Locally the nostrils and throat should be frequently washed or irrigated with some active detergent lotion, as Condry's fluid or Thiersch's solution, and afterwards well dusted with iodoform by means of an insufflator. Ulceration upon the skin should be similarly treated, and, if deep and foul, should be actively stimulated by dilute nitric or hydrochloric acid.

The treatment is very unsatisfactory, and few cases recover.

#### WOUNDS POISONED BY CONTACT WITH THE FLUIDS FROM RECENT DEAD BODIES.

Wounds of this character are infected either with a specific germ, or with the products of putrefaction resulting from the action of germs upon dead animal matter. They are very seldom encountered in childhood, unless accidentally received through the contact of an abrasion or wound in playing with or handling the bodies of dead animals. When met with, the peril equals that of similar wounds in the adult, and for this reason they merit brief consideration. In the adult they are of much more frequent occurrence, and occur in the form of dissection-wounds, or the wounds received by butchers, "fallmasters," and persons engaged in handling half-putrid hides.

It has long been known that dangerous and even fatal consequences follow wounds received in the dissection of human bodies. Two forms of poisoning, apparently depending upon the virulence and activity of the poison, are met with,—the mild and the severe. A third form, perhaps not properly a wound, is occasionally seen in the form of dark-colored warty excrescences, the so-called "anatomical tubercle," or verruæ necrogenicæ, on the hands and about the knuckles of persons engaged in handling dead bodies. As this third form is due to the influence of an irritant, removal of the cause and the application of mild antiseptic lotions—as weak sublimate solution or a borated ointment—are all that will be required in the way of treatment.

The mild form of poisoned wounds is attended by a moderate degree of inflammation, with some redness and tenderness along the course of the lymphatics leading from it, and more or less constitutional disturbance. This usually subsides in a few days, or culminates in the formation of a circumscribed abscess at the seat of the wound or in the axillary glands. The febrile excitement disappears with the discharge of the pus. The prog-

nosis is favorable, and little is required in the way of treatment, except to modify the severity of the local inflammation by cooling lotions and the evacuation of the pus as soon as it can be detected. If the patient is feeble, quinine with the mineral acids will hasten recovery.

The severe or acute form of dissection-wounds, usually received in the dissection of a recently-dead human body, or by contact of a wound with animal matter which has not advanced too far in decomposition, is followed by the rapid development of symptoms of the most alarming character, indicating the local effects and constitutional consequences of a virulent specific poison. Undoubtedly the condition of health of the wounded person, as well as the character or source of the poison with which he is infected, modifies the final result. Persons in feeble health or exhausted by overwork are ill prepared to resist the effects of the toxic agent, and the wounds contaminated during the dissection of bodies in which death has resulted from puerperal peritonitis, scarlet fever, or erysipelas are peculiarly liable to be followed by fatal results.

Usually at the end of twenty-four or forty-eight hours after contamination the wound becomes painful, and a minute vesicle or pustule appears at the seat of lesion. This is rapidly followed by an extension of the inflammation towards the body; a red and painful line marks the course of the lymph-vessel leading to the axilla, the epitrochlear and axillary glands become indurated and tender, and the hand and arm swell rapidly and enormously. Severe and frequently-recurring chills followed by febrile heat, violent pain in the back, deadly nausea with constant efforts to vomit, rapid and feeble pulse, extreme restlessness, intermittent delirium, and utter prostration mark the constitutional effects. In the worst cases gangrene attacks the wound and extends to the hand and arm, abscesses form on the axilla and beneath the pectoral muscles, deep and violent erysipelatous inflammation extends over the side of the chest from the clavicle to the buttocks, and the skin, greatly congested and indurated, becomes dusky brown or black in color from the supervention of gangrene. The constitutional symptoms are rapidly aggravated, and low muttering delirium, frequent, feeble, or imperceptible pulse, cold damp skin, and extreme depression of all the vital powers mark the approach of death, which usually occurs from coma and exhaustion. The fatal result sometimes occurs very early; in one case of which I have personal knowledge, death took place forty-eight hours after the onset of the symptoms.

The poison usually finds entrance through some trifling wound on the finger or hand, as the puncture of a needle or spicula of bone; but any scratch or abrasion may absorb it. Sir James Paget believes that the poison from which he suffered was absorbed by the unbroken skin from the pleuritic fluid with which his hands were bathed during a post-mortem. "It soaked through the skin. I had no wound or crack of any kind."<sup>1</sup>

---

<sup>1</sup> Clinical Lectures.

Hayward states<sup>1</sup> that he wounded his forefinger very slightly with several needles, and soon afterwards touched the intestine of a child that had recently died of peritonitis. Fourteen hours afterwards he was aroused from sleep by intense pain in the wounded finger, which soon became swollen, livid, and finally gangrenous. Severe constitutional symptoms followed, but he recovered in a month.

In my own case the poison was absorbed through an abrasion on my left middle finger, from the fluids in the peritoneal cavity of a man who had died eight hours previously from gangrene of the bowels. Forty hours afterwards the hand became excessively painful, and constitutional symptoms of very great severity followed rapidly. Despite free incision, the hand and arm swelled to double their natural size, and abscesses formed in the course of the lymph-vessels. The symptoms subsided in a fortnight, but the hand remained swollen, stiff, and useless for many months.

All cases do not terminate so happily. Travers<sup>2</sup> mentions the case of a student who, after puncturing his finger while examining the body of a man that had died in the hospital, himself expired within forty hours afterwards from the effects of the puncture, with symptoms nearly resembling those of hydrophobia. Dr. Christy, in this city, punctured his finger with a needle while finishing an autopsy upon a man dead of erysipelas; at the end of the second day afterwards his arm showed marked evidences of poisoning, and forty-eight hours later he died from its effects. The literature of surgery abounds with similar histories.

The nature of the specific poison (or poisons) has not yet been absolutely determined, but it undoubtedly belongs to the ptomaines or volatile alkaloidal products of putrefaction of animal matter. Bergmann in 1866 first isolated a crystallizable substance, sepsin, from putrid blood, which when injected into the tissues of animals he found to be actively poisonous by the production of a fatal form of septicæmia. The investigations of Zuelzer and Sonnenschein, Selmi, Rörseh and Fasbender, Brieger, Gautier, and others led to the discovery of a number of other volatile alkaloids or ptomaine substances (Selmi) in dead human or animal bodies and in decomposing albuminous matter, among which may be mentioned putrescine, mydaleine, choline, mydatoxine, tetanine, etc. Several of these putrid products are isomeric with the vegetable alkaloids and correspond more or less closely with them in their physiological effects, all of them being actively poisonous and rapidly destructive to life when injected into the tissues of the lower animals.

**Treatment.**—The treatment of poisoned wounds of the character under consideration necessarily varies with the period at which it is instituted and the severity of the symptoms. All wounds received in post-mortem examinations, or in any way liable to become infected by the poison-

<sup>1</sup> Remarks on Dissection-Wounds, American Journal of the Medical Sciences, January, 1844.

<sup>2</sup> Essay on Constitutional Irritation.

ous emanations from dead animal matter, require prompt and energetic treatment. The wound should always be well washed with soap and running water, and immediately afterwards cauterized with fuming nitric acid, strong hydrochloric acid, or acid pernitrate of mercury. Nitrate of silver is entirely too feeble an agent to be of any service; it forms an insoluble albuminate of silver, which covers the wound like a scab and interferes with the escape of serum; its effects are very irritating to the wound, but it does not destroy any poison which may have entered it. Where no wound exists, but the hands have been brought in contact with putrefying animal matter, they should always be thoroughly cleansed with soap-and-water and afterwards washed with strong acetic acid.

When the poison has been absorbed and local and constitutional symptoms appear, the treatment must be supporting and eliminative. Morphine or opium will be required to relieve pain, lessen the shock of the onset of the attack, and secure rest. In my own case a full dose of morphine given hypodermically afforded marked relief, and probably enabled me to resist the depressing influences of the poison.

Mild catharsis by calomel or Rochelle salt will be useful by increasing hepatic activity. Quinine in large doses—six to eight grains every four hours to an adult—will, next to morphine, prove the most valuable remedy, and champagne or brandy-and-soda will be useful in allaying gastric irritability and supporting the strength. The diet must be of the most nutritious quality,—concentrated animal broths, beef peptonoids, milk, eggs, etc.,—and a moderate quantity of wine will be required. No actively-depleting measures should ever be adopted, and, if signs of depression are urgent, active stimulation by wine, brandy, ether, etc., is demanded.

The condition of the wounded part will require attention, but no further cauterization of the wound is permissible. The limb should be enveloped in cloths wrung out of a hot antiseptic solution, and slightly elevated. If the swelling increases rapidly, free incisions must be made in the part, so as to afford sufficient outlet for the putrid serum or pus which may be present and to relieve the tension of the skin. This is especially necessary when the inflammation assumes the form of diffused cellulitis or when gangrene attacks the skin; and the incisions must be free enough to liberate the pus and permit the discharge of dead cellular elements. Abscesses usually form at the bend of the elbow, in the axilla, or under the pectoral and trapezius muscles. They must be evacuated by free incisions as soon as detected, and drainage secured afterwards. In cases of deep-seated local tenderness and induration without distinct fluctuation, it is always wise to search for pus by introducing the needle of a hypodermic syringe or aspirator, and if a deeply-located abscess is reached it must be opened at once and treated antiseptically. Recovery is always tedious, and the health is often permanently impaired.

## COMPLICATIONS OF WOUNDS.

It is probable that every variety of wound-complication depends upon septic contamination and is therefore preventable in a majority of cases. These complications are met with under two conditions: first, morbid processes depending upon specific forms of microbial infection,—tetanus, erysipelas, spreading gangrene, and phagedæna, and in a mild form lymphangitis and lymphadenitis; second, constitutional disturbances depending on septic germs present in suppuration,—sapræmia, septicæmia, and pyæmia.

## MORBID PROCESSES DEPENDING UPON SPECIFIC FORMS OF MICROBIC INFECTION.

**TETANUS.**—This terrible complication is met with at all periods of life, at all seasons of the year, and after every imaginable form of wound. Age does not influence its occurrence, and it is encountered in about equal frequency in children and in adults, nearly sixty per cent. of the cases occurring between the tenth and the thirtieth year. It is a disease marked by violent continued *tonic* spasms, involving all the muscles of the body (except those of the hands), and most severely affecting the muscles of the back and those of mastication, deglutition, and respiration. The spasm is continuous and unremitting, and is aggravated at variable intervals by the occurrence of sudden paroxysms during which the intensity of the muscular contraction is violently increased. It may follow the most trifling injury. I have seen it follow a slight wound of the thumb in a boy of seventeen years, a crush of the tip of the ring finger in a child of seven, a lacerated wound of the skin over the knee in a boy of nine, and an operation performed by a dentist upon an inflamed tooth in a boy of thirteen. No wound is free from this danger. Exposure to cold after a wound is a common predisposing cause. On the other hand, prolonged heat during the day, followed by damp, chilly nights, seems to favor its development.

It is probable also that wounded persons who sleep near the earth are more liable to be attacked than those who occupy upper rooms.

No characteristic train of symptoms can ever be relied upon as indicating the approach of tetanus, but the first complaint which attracts attention usually indicates the nature of the malady. The attack comes on generally from the second to the tenth day after the injury. Mr. Poland<sup>1</sup> tabulates two hundred and seventy-seven cases, as follows:

“ Previous to the tenth day . . . . .	130 cases, of whom 101 died.
From the tenth to the twenty-second day . . . . .	126 cases, of whom 65 died.
Above twenty-two days . . . . .	21 cases, of whom 8 died.”

My own observations in thirty-two cases confirm the opinion that an early attack is always extremely violent and rapidly fatal. In all the fatal cases which I have seen, the attack came on before the tenth day, in some

<sup>1</sup> Holmes, System of Surgery, 3d ed., vol. i. p. 202.

of them as early as the third day, and in most before the sixth day after the injury. The cases which occurred after the tenth day were usually milder and more easily controlled, though they did not all recover.

Usually the first symptoms of which the patient complains are slight sore throat, with some stiffness and soreness about the back of the neck; and this complaint is usually made at the morning visit. If the face of the patient is now closely scrutinized, a peculiar expression of countenance will be observed; the brow is very slightly wrinkled, the eyelids and lips seem drawn at the angles, and if an attempt is made to protrude the tongue it is done with difficulty, and the jaws cannot be separated widely.

The wound almost always assumes a dry, unhealthy appearance, and repair ceases. The disease has already commenced. The muscles of the neck, back, chest, and abdomen rapidly become involved in the general rigidity, the tightly-drawn lips compress the teeth, the eyelids hug the eyeballs and give the eyes a staring expression, the brow is corrugated, and the face grins with the *risus sardonius*. The pain of a universal cramp seizes the muscles, the body is bent backward, the jaws become clinched, deglutition and respiration become difficult, and violent paroxysms of spasm increase the suffering and imperil life by impeding respiration. During these paroxysms the jaws, if separated, close with a snap, and the tongue when caught between the teeth is terribly bitten; respiration is almost impossible, the face is livid, and the breath is forced through the clinched teeth with a hissing sound, and, carrying the saliva with it, covers the lips with a bloody foam. The tongue is foul, and the skin bathed in perspiration. The pulse is not greatly accelerated except during the paroxysms, and the temperature seldom exceeds 103° F. except just before death, when it has been known to reach 112° F. The mind remains clear until the end, unless disturbed by the influence of drugs given to relieve the spasm. Death occurs by asphyxia or exhaustion.

The exact pathology of the disease is obscure, and the pathological appearances are by no means constant or characteristic. Lockhart-Clarke, Clifford-Allbutt, Dickinson, and others have described changes in the medulla and spinal cord, transparent exudation around the vessels, greater in the gray than in the white structures, granular degeneration, or actual cavities, in the gray substance, exudations in the gray matter of the posterior columns, and alterations in the ganglion-cells. Other observers, equally careful and competent, have failed to discover these changes. It is evident that the disease is not a myelitis and that it is not inflammatory.

The recent observations of Nicolaïer and Rosenbach seem to establish the fact that the disease is septic in origin and depends upon the entrance of a specific microbe or bacillus into the wound. Verneuil contends that the specific virus exists in the excretions and emanations from horses, and that wounds so contaminated are very liable to be followed by tetanus.<sup>1</sup>

---

<sup>1</sup> Revue de Chirurgie, October and December, 1887.

Nicolaïer has succeeded in producing a disease similar to tetanus by introducing garden earth beneath the skin of guinea-pigs and rabbits; and Beumer and Rosenbach have obtained similar results by inoculating mice, rabbits, and guinea-pigs with pus taken from the wounds of tetanic patients, and also from cultivations (in blood-serum) of the bacillus obtained from the same source. Hochsinger has produced tetanus in rabbits by injecting the blood drawn from a tetanic patient during life. Brieger<sup>1</sup> isolated four toxic ptomaines from cultivation of the bacillus tetani,—namely, tetanine, tetano-toxin, toxin-muriate, and spasmotoxin,—all of which produce convulsive movements with well-marked tetanic symptoms in animals (rabbits); and he has also isolated tetanine from the amputated arm of a man suffering from tetanus. These observations seem to establish beyond cavil the dependence of the tetanic condition upon certain specific toxic agents produced by the action of a bacillus upon the albuminous matter in the wound; these toxic agents influence the medulla oblongata and spinal cord in a manner similar to strychnine; and they also prove that the disease is communicable from one animal to another and probably to man, though transmission from man to man has not been proved.

The diagnosis of tetanus in childhood is not difficult: the previous existence of a wound, the manner of onset of the disease, the more or less rapid progress and constantly-increasing severity of the tonic contractions, the inability to open the jaws or protrude the tongue, and the absence of delirium or spectral illusions are unfailing guides to a correct diagnosis.

The prognosis is generally unfavorable. The venerable Prof. S. D. Gross stated that in a practice of fifty years he had seen but three recoveries. Hennen never saw a recovery from acute traumatic tetanus. During our late civil war three hundred and sixty-three cases were reported, with twenty-seven recoveries. In my own personal experience seven cases have recovered in thirty-two cases attacked, and I have reliable information that two other cases recovered in the practice of another surgeon in this city. Death may occur from the second to the twentieth day or even later; in one case in my own practice it occurred on the sixteenth day.

**Treatment.**—The treatment is both local or prophylactic, and general or symptomatic. The local treatment consists in the removal of every possible source of irritation or infection from the wound, and the protection of the wound-surfaces from contact with the germ-charged air or with other and more tangible sources of contamination. A rigid antisepsis after thorough cleansing of the wound is the best prophylactic measure. Care must be taken that no impure water, or water obtained from troughs used by horses, and possibly contaminated by their excrement, should ever come in contact with the wound.

The patient must be kept in a warm, quiet room, preferably on an upper floor, and must be carefully guarded from draughts of cold air. If the

---

<sup>1</sup> Virchow's Archiv, Bd. xcii., H. 3.

wound is sloughing and unhealthy, it must be cleansed as thoroughly as possible and enveloped in a warm antiseptic dressing. The medicinal treatment is very unsatisfactory, and in the majority of cases is confined to efforts to prolong life and to afford some degree of relief from the terrible suffering. The disease is fearfully exhausting, and the strength must be supported by a nutritious liquid diet,—rich, strong broths, milk, eggs, etc.,—with a moderate quantity of wine or brandy. As it is often impossible for the patient to swallow anything, his food must either be given by rectal enemata, or preferably by means of the stomach-tube, introduced through the nostril and pushed well down the œsophagus. A few ounces of broth or other liquid aliment can easily be thrown into the stomach through this tube by means of a syringe, and can be repeated at intervals of one or two hours without annoying the patient or adding to his distress.

The remedies which possess any real value in mitigating the violence of the disease are few in number. Chloral, bromide of ammonium, pilocarpine, Calabar bean and its alkaloid eserine, coniine, atropine, and morphine are the most valuable.

Chloral, alone or in combination with the bromide of ammonium, is probably the remedy upon which most reliance can be placed, and in my own experience has yielded the best results. It must be given in doses sufficiently large to control the muscular spasms and to procure sleep; after this is attained the patient must be kept in a condition of mild chloral intoxication until the violence of the attack has passed. It must be given in full doses, but its effects should be watched, and as soon as the spasm relaxes it should be withdrawn temporarily or the dose lessened and the bromide of ammonium substituted for it. Five grains of chloral with an equal quantity of the bromide may be given hourly or every second hour to a child of five years, as long as the intensity of the spasms continues, but it must be withdrawn as soon as relief is obtained. Owing to its tendency to weaken the heart, this effect must be counteracted by moderate alcoholic stimulation and an abundant nourishing diet. In four out of seven cases of recovery in my own experience, favorable results followed the combination of chloral with bromide of ammonium.

Pilocarpine given hypodermically has recently been employed with success by Dr. L. Cassati, of Forlì,<sup>1</sup> in three cases (in one after failure of chloral and bromide of potassium). The dose given was one centigramme every two hours night and day, and in one very severe case seventy centigrammes were given in fifteen days. Beneficial results have been obtained from eserine given in a daily quantity equal to one-fourth or one-third of a grain; the tincture of Calabar bean is not reliable, or at least has yielded no results in my hands.

The bromide of coniine has been successfully used by Demmer, in a single dose of one-sixth of a grain to a boy, hypodermically, followed by

---

<sup>1</sup> Raccoglitore Medico.



one-twelfth-grain doses internally every two hours. Atropine and morphine are useful by temporarily allaying the violence of the spasm and in securing rest: in one instance recovery followed the combination of morphine with bromide of potassium.

Where recovery occurs, there is a gradual relaxation of the tonic spasm, the paroxysms become milder and less frequent, and the patient is convalescent in from two to six weeks; some rigidity of the jaws remains for many weeks after the disease has terminated.

**LYMPHANGITIS.**—Inflammation of the lymphatic vessels occurs as an occasional consequence of every variety of injury, whether wound, abrasion, or sprain, and is more frequently met with in childhood than in adult life. An irritative or inflammatory process starts in the wound and involves the lymph-radicles in the vicinity, spreading from thence to the larger lymph-channels; these become inflamed, and extend in red painful lines towards the trunk, involving the glands with which they communicate. Commonly the attack is ushered in by a chill followed by febrile excitement, with nausea, headache, thirst, and prostration of strength. If several lymphatics are involved, the part becomes hot, painful, and oedematous, and the glands in the line of the inflamed channels are swollen and tender.

The inflammatory process involves the entire structure of the walls of the lymph-vessels, and may spread from thence to the adjacent tissues; the contents of the vessels become turbid or even puriform, and the vessels themselves may be obstructed by coagula or obliterated by inflammatory thickening. In severe cases the process ends in suppuration in the lymph-vessels and in the surrounding connective tissue, with sloughing of the adjacent parts. In mild cases resolution occurs in a few days; the red lines disappear from the skin, and the tissues regain their natural appearance. Some oedema is apt to remain for some time after the subsidence of the inflammation, and the swollen glands continue to be tender and painful. This swelling usually subsides slowly and ultimately disappears, but in severe cases or in badly-nourished children may end in suppuration, which does not cease until the entire gland is destroyed.

The occurrence of lymphangitis indicates the existence of a mild form of sepsis; but, unless dependent upon infection of the wound with some of the products of decomposition, it is almost free from danger.

**Treatment.**—The wound, if one exists, should be thoroughly cleansed and treated by warm antiseptic fomentations; if collections of pus exist, they must be freely opened by incisions, so as to allow escape for the discharges. If the limb is hot and tender, cool anodyne lotions, as the common lead-and-landanum lotion, will be serviceable; and elevation of the limb will add to the comfort of the patient. Internally a mild saline cathartic followed by full doses of quinine should be given, and will usually be all the medication required.

**LYMPHADENITIS.**—The lymphatic glands are inflamed as a secondary

result of the absorption of morbid or septic material from a wound, or by extension from an inflamed lymphatic vessel. It may also result from direct injury to the gland. The gland swells, and becomes hot, tender, and firmly attached to the surrounding structures. The blood-vessels dilate, an exudation of leucocytes invades the gland, blocks the lymph-channels, and extends to the surrounding tissues, and the gland is hard, resisting, and painful. The ultimate result depends upon the severity of the process and upon the mode of treatment adopted. In mild cases the inflammatory process abates, the hyperæmia diminishes, and resolution follows. The exuded leucocytes are absorbed or undergo fatty degeneration, and the gland softens and decreases in size. In severe cases the tension within the capsule of the gland increases until the capillaries are obstructed by the pressure, and necrosis of its structures follows. An abscess speedily forms, and when opened discharges a quantity of grumous pus and broken-down gland-tissue. Sometimes the inflammation assumes a chronic form, and the gland ceases to be painful, but remains swollen and indurated for an indefinite period. Having once been inflamed, a gland rarely returns to a perfectly normal condition, but remains as a possible focus for future tubercular manifestations.

**Treatment.**—Cleansing of the wound and removal of all sources of irritation, with rest to the part, are indispensable elements of treatment. During the early acute stage cold by means of an ice-bag affords relief by lessening the hyperæmia and thus retarding suppuration. Later, warm fomentations are usually more agreeable to the patient, and when it is evident that suppuration cannot be prevented they should always be employed to hasten that result. As soon as pus can be detected it should be evacuated by an incision large enough to allow free escape for the pus and débris of the disintegrated gland-structure. The cavity should be washed out with a warm solution of boric or carbolic acid, and hot antiseptic fomentations continued until the discharge ceases. When the pus shows a disposition to burrow beneath the skin, the edges of the wound and the track of the forming sinuses must be laid open, the pyogenic membrane which covers the surface destroyed, and the cavity packed with carbolic or iodoform gauze, so as to secure healing from the bottom of the cavity. When the glands do not suppurate, but remain swollen and tender, resolution may be hastened by the application of an ointment of the iodide of lead or iodide of cadmium. The general health of the patient requires attention, and tonics and nutritious food are indispensable.

**ERYSIPELAS.**—An “acute, spreading, and infectious inflammation of the skin, or of the subcutaneous connective tissue,” is occasionally met with as a complication of wounds which have not been well cared for or which occur in feeble cachectic persons with bad sanitary surroundings. Its origin is undoubtedly microbial, and due to infection (of the wound) with a specific materies morbi, the *streptococcus erysipelatosus*, which enters the tissues through a lesion on the surface, no matter how insignificant, and

diffuses itself by the lymph-channels through wide but sharply-defined areas or zones of tissue, and gives rise to distinct, severe, and often destructive forms of inflammation in the invaded structures. What seems to be positive evidence of the dependence of erysipelas upon microbial infection has been furnished by the observations of Orth, Lukomsky, Tillmanns, and Koch, confirmed by the successful cultivations of the specific microbe by Fehleisen, and the transmission of the disease to animals and to man through inoculation from these cultivations. Erysipelas is very rarely encountered in childhood, and is usually very mild in its course; but in very young infants it is extremely fatal. Most of those attacked within the first month after birth perish. It is not uncommon in infancy, and generally starts from an abrasion on the lips, at the angle of the mouth, or upon the genitals. It almost invariably assumes the mild or cutaneous form, and, although attended by an active febrile disturbance, is nearly always easily controlled. As a complication of wounds it may be entirely prevented by a careful antiseptic. A mild mercurial cathartic, followed by tonics, as quinine and tincture of the chloride of iron, with local applications of weak solutions of sublimate or the ordinary lead lotion, is commonly all that is required. For further details the reader is referred to the article on erysipelas.

GANGRENE and PHAGEDÆNA, except as seen in the specific form of noma or cancrum oris, or when dependent upon complete obliteration of the blood- and nerve-supply of a part, are extremely rare in childhood, and spreading traumatic gangrene is almost unknown. I have never met with it before the twentieth year.

#### CONSTITUTIONAL DISTURBANCES DEPENDING ON THE SEPTIC GERMS PRESENT IN SUPPURATION.

Three forms of blood-contamination, closely related to one another and frequently occurring together in the same subject, though dependent upon distinct conditions, are met with as results of wounds at all ages,—viz., *sapræmia*, *septicæmia*, and *pyæmia*. Although less frequent and far less serious in childhood than in adult life, they nevertheless merit brief consideration, as the most serious and fatal of all complications.

A certain degree of pyrexia follows nearly every severe form of wound or injury, even when subcutaneous and aseptic,—due in part to the local irritant effect of the traumatism, but probably in greater degree to absorption of some leucomaine-substance which is developed in the fluids poured out at the seat of injury, and which possesses qualities capable of temporarily disturbing the functions of the heat-centres: a mild form of so-called traumatic or “inflammatory” fever results. This soon disappears, probably by elimination of the exciting cause.

SAPRÆMIA, PUTRID INTOXICATION, OR TOXIC MYCOSIS OF THE BLOOD.—When unsterilized air gains access to a wound, certain microorganisms are carried with it, and, if among them are those saprophytic

germs which thrive in the various putrescible fluids that bathe its surface, "they break up the complex organic compounds and reduce them to simpler forms." (Cheyne.) Decomposition, fermentation, and chemical changes result, and the various unstable alkaloidal products of putrefaction are formed abundantly. As already stated elsewhere, many of these animal alkaloids, or ptomaines, possess intensely noxious properties, and are actively poisonous to all animals and to man. They are not destructible by boiling, even if it be prolonged for ten hours. They require no period of incubation, but, when absorbed into the blood in sufficient quantity, immediately develop most violent and dangerous symptoms, and may destroy life in a few hours. The *materies morbi* is a chemical product resulting from putrefaction of the albuminous wound-secretions; it is not a germ, but is the product of germ life, and the chain of symptoms to which the term *sapremia*, *septic intoxication*, or *putrid intoxication* is applicable results from its toxic effects upon the blood and the nerve-centres. Every imperfectly-drained wound, abscess, or granulating surface which becomes infected is a source of danger from absorption of these putrid substances. No germs are present in the blood immediately after death. The blood coagulates imperfectly, the red corpuscles are disintegrated, the lining membrane of the vessels and that of the heart are darkly stained, and decomposition progresses rapidly. The symptoms of putrid intoxication are those present in the bad forms of dissection-wounds,—viz., severe chill, followed by sudden rise of temperature to 104° or 106° F., vomiting, thirst, frequent or irregular pulse, delirium, and extreme prostration; and if the quantity of the poison absorbed is large, or if absorption continues, collapse, bloody diarrhœa, coma, and death follow one another with startling rapidity.

The treatment involves efforts to prevent further absorption of putrid material, by cleansing and draining the wound. This must be done by washing its surface with antiseptic and detergent lotions, relieving tension by the removal of sutures or by evacuating abscesses, affording abundant outlet for the discharges, and guarding against further infection by antiseptic dressings. The internal treatment should be eliminating and supporting,—free mercurial catharsis if prostration is not present, followed by full and frequently-repeated doses of quinine, with nourishing food and moderate alcoholic stimulation.

**SEPTICÆMIA.**—This condition is caused by infection of the living tissues, and later of the blood, with certain specific micro-organisms, which, after a brief period of incubation, multiply rapidly in the blood and tissues, causing capillary embolisms and thromboses, impairing the nutrition, "deranging the function of important organs" (Senn), and causing the formation of ptomaines within the living body. The effects do not depend upon the dose: the smallest quantity inoculated into the tissues is followed by the specific results in all their intensity. The blood after death teems with microbes (most commonly the *staphylococcus pyogenes albus*), and if inoculated into another animal produces the same specific train of symptoms as

were observed in the first subject. When once established, the tendency of septicæmia is towards death: there is a gradual and progressive increase of all the symptoms, without any improvement, such as is seen occasionally in sapræmia after the source of the poison in the wound is removed.

Two forms of septicæmia, the acute and the chronic, are recognized. The acute form is probably complicated by the coexistence of the sapræmic condition. The symptoms therefore vary with the nature of the attack. Ordinarily in the acute form they are those of sapræmia. The wound shows some evidence of inflammation,—is hot, painful, and contains a small amount of pus. The attack is usually preceded by a distinct rigor, followed by rapid increase in temperature; there are nausea, thirst, headache, watchful, anxious delirium, feeble, frequent pulse, rapidly-alternating temperature, and marked loss of strength. The urine is scanty and albuminous, and the bowels are greatly relaxed. Collapse followed by coma precedes death, which occurs from the fourth to the seventh day. In the chronic form the symptoms are milder, and the disease runs a more protracted though rarely less fatal course, sometimes lasting for three weeks, the skin in the mean time being covered by petechial spots, or by an eruption resembling that of scarlet fever. Pneumonia, bronchitis, or pericarditis may hasten the fatal result.

The morbid changes are similar to those seen after sapræmia: the serous cavities contain bloody serum; the liver, spleen, and lungs are congested and softened; the blood is almost diffuent and contains micro-organisms (*staphylococcus pyogenes albus*) in abundance, but abscesses are extremely rare.

**Treatment.**—The wound should be drained and disinfected as advised in sapræmia, in the hope of preventing further infection. Beyond this the general treatment consists in supporting the strength by nutritious food, moderate stimulation, and full doses of quinine. Sulphurous acid, hyposulphite of sodium, and salicylic acid are worthy of trial; but the treatment is generally very unsatisfactory.

**PYÆMIA.**—This term is applied to a pathological condition which, though intimately related to sapræmia and septicæmia, differs from both of them in the clinical fact that during its progress secondary or metastatic abscesses form in various portions of the body, and that fever of an intermittent character is commonly present. Occurring only while the suppurative and putrefactive processes exist in some part of the body, it evidently depends upon contamination of the blood by some materies morbi present in the suppurating part, most probably by the micro-organisms of suppuration, and possibly with other forms of microbial infection. The noxious element probably gains access to the blood through the medium of a suppurating surface, by first infecting the minute clots or thromboses which are so abundant in the capillaries at the surface of a wound, and which under the influence of the microbes of suppuration do not organize, but break down in minute semi-purulent fragments, and, in the form of infected

emboli, are disseminated to every part of the body by the blood-stream. They are finally arrested in the smallest vessels or capillaries, where they cause hemorrhagic infarctions or localized necroses and become the foci for new septic inflammatory processes, ending in the formation of abscesses. Every organ in the body—the lungs, liver, spleen, serous cavities, joints, and connective tissues—may thus become the seat of fresh purulent collections. The pus from such metastatic abscesses contains the same forms of micro-organism as are present in the wound or other source of infection. Rosenbach (quoted by Senn) has detected streptococcus pyogenes and occasionally staphylococci in the pus and in the blood of pyæmic patients. Besser, of St. Petersburg, has made similar observations, and Schüller has found streptococci in metastatic abscesses in the joints in cases of puerperal pyæmia.

Infection may occur at any time in any septic (and suppurating) wound, though most generally met with in wounds or other injuries which implicate the medulla of bone or in which blood-vessels (veins) are punctured by bony spicula. Pyæmic invasion may or may not be preceded by a brief period of feverishness; but its onset is usually announced by a severe rigor, quickly followed by a marked rise in bodily heat,— $103^{\circ}$  to  $108^{\circ}$  F. The rigors recur at irregular intervals, and the temperature undergoes wide and abrupt variations, rising or falling five or six degrees in a few hours. The wound assumes an unhealthy appearance, its edges are œdematous, the granulations become pale and shrivelled, and the discharge is offensive. The pulse soon becomes frequent and feeble, the tongue is red, dry, and glazed, and the teeth are covered with sordes; the skin is icteric, bathed in clammy perspiration, and exhales a sweetish, sickening odor; respiration is hurried, tremulous, and irregular, and a peculiar watchful delirium is present. At about the end of the first week of illness, purulent (metastatic) collections appear in different parts of the body, unpreceded by the usual local evidences of phlegmonous inflammation. A slight degree of redness and swelling appears in the skin, or a joint becomes distended by effusion; a rapid formation of pus follows, and the resulting embolic abscess, when opened, discharges a quantity of dirty, grumous pus, loaded with débris of broken-down connective tissue, and swarming with micro-organisms. Low, muttering delirium takes the place of the previous vigilant form, bloody discharges occur from the bowels, extensive bed-sores or sloughs form wherever there is pressure, the body wastes with fearful rapidity, and the patient dies of exhaustion by the end of the second or the early part of the third week.

**Pathology.**—The chief post-mortem appearances are purulent collections or embolic abscesses disseminated throughout various portions of the body,—in the joints, in the serous cavities, and in any or all of the viscera,—petechial spots beneath the skin and serous membranes, disintegration of the blood, and a marked tendency to early and rapid decomposition.

**Treatment.**—Pyæmia is a malignant sepsis, and, in acute cases, all its

processes tend to a fatal result. The treatment must therefore be directed to prevention rather than to cure. Pure air, proper hygienic conditions, and a rigidly antiseptic treatment of the wound consequently become important prophylactic measures. When the disease is fairly established, little can be done to counteract the lethal tendency. The treatment must be supporting and stimulating throughout. If, however, the disease is recognized early, it will generally be proper to precede the adoption of the supporting treatment by a moderately active mercurial catharsis by full and repeated doses of calomel. Used early and given in positive doses, so as not only to purge, but also to deplete mildly, this measure in my hands has seemed to control dangerous symptoms and to avert morbid processes which threatened to be very destructive. If possible, the wound should be rendered aseptic by the plentiful use of detergents; free escape must be provided for future effusions, and its surfaces must be protected from further infection. Abscesses, whether involving the joints or other accessible portions of the body, should be opened, drained, and treated antiseptically as soon as detected. No possible good can arise from the presence of the retained pus, and unless speedily evacuated it has a marked tendency to burrow widely beneath the fascia and along the intermuscular planes, and thus adds to the constitutional distress. When a joint is involved, it should be freely opened on both sides, drainage-tubes should be inserted, and the limb rendered immovable by a fixed dressing. Internally, quinine in full doses, with sulphurous acid, salicylic acid, and the hyposulphites of sodium and lime, is worthy of trial. Nutritious broths, milk, and wine are indispensable. The patient must be kept alive as long as possible, in the hope that he may survive the activity of the attack and eventually eliminate the poison.

# ANÆSTHETICS AND ANÆSTHESIA.<sup>1</sup>

BY OSCAR H. ALLIS, M.D.

---

THE terms "anæsthetics" and "anæsthesia" are both from the Greek *α*, privative, and *αἰσθάνομαι*, "to feel." The former has reference to the agent that deprives of feeling, the latter to the condition of the patient or animal under the influence of such agent. It is plain that the subject has a wide range and includes all agents that have either a local or a constitutional anæsthetic effect. The present article will be restricted to the consideration of ether and chloroform and their employment for the relief of pain in surgical operations.

**Ether.**—In the year 1540, Valerius Cordus described the method of making ether. I have seen no mention of the discoverer. It is thought that the drug was known to Raymond Lully two centuries earlier. In 1730, Frobenius first brought it prominently before the medical and scientific world and gave to it the name of ether. In 1795, Richard Pearson employed the vapor of ether in allaying pulmonary distress. In 1799, Sir Humphry Davy, writing of nitrous oxide, said, "it will probably be used with advantage during surgical operations in which no great effusion of blood takes place." In 1818, Faraday published a brief notice of it, in which he alluded to its anæsthetic effect, but with a caution, that was no doubt accepted and promulgated in medical schools.

The knowledge of the fact that physicians had recommended it for a long time for spasmodic pulmonary affections, no doubt led drug clerks to familiarize themselves with its effects, and, strange to say, just prior to its more general introduction it was purchased and inhaled by riotous youth for its exhilarating effects. Being familiar with this fact, and knowing that a negro boy had recovered from an hour of deep sleep and total unconscious-

---

<sup>1</sup> Many diseases are almost peculiar to infancy and early childhood, and when they occur in adult life the experience derived from their study in childhood is turned to the advantage of the adult. In regard to anæsthetics the reverse obtains. What we know of their clinical effects and dangers is derived chiefly from their employment in adult life. If we compare the surgical maladies and accidents of childhood with those of adult life, we shall find that the demand for anæsthetics in the latter is much more frequent than in the former. In the limited space allotted this subject, I shall treat first of matters of general interest, adding from time to time that which is peculiar to infancy and childhood.



ness from its use, Dr. C. L. Long, of Georgia, turned his knowledge of the effects of ether to a practical use by administering it to a patient for the purpose of removing a tumor from the neck. Success was complete, and other patients were induced to inhale the drug for the same purpose and with similar results. This occurred in 1842, and had Dr. Long realized the value of his discovery and given it to the world his name would have been bright in the galaxy of imperishable names.<sup>1</sup>

A little later (1844), Horace Wells, a Hartford dentist, was present at a public exhibition of the effects of laughing-gas upon persons to whom it was administered. Recognizing its benumbing effect, he on the following day requested Mr. Colton, the lecturer, to administer it to him while he had a tooth extracted. This was done, and Mr. Wells, having felt no pain, turned his experience to the advantage of his patients. Having satisfied himself of its value in dentistry, he believed that its application could be extended to surgery, and offered to give a practical demonstration before the medical students of Harvard. During the extraction of a tooth the patient screamed, though on recovering consciousness he confessed that he had experienced no pain. The result must have been extremely mortifying to Mr. Wells, for he seems from that moment to have lost confidence in the entire project.

The work of Mr. Wells had, however, its good effect, for a student of his, W. T. G. Morton, no doubt relating the experiments of his preceptor to Charles T. Jackson, a distinguished chemist, was induced by a suggestion of the latter to make trials with ether. Full of ardor, he went home to inhale it himself, and soon after extracted a tooth from a patient under its influence. On the 16th of October, 1846, Morton etherized a patient in the Massachusetts General Hospital, from whom Dr. J. C. Warren removed painlessly a tumor of the neck. Thus was given to the world the first practical demonstration of the value of ether as an anæsthetic in surgery.

**Chloroform** was discovered in 1831 by Samuel Guthrie, of Sackett's Harbor, New York. In 1834 its chemical formula, from which it derives its name,—viz., *perchloride of formyl*,—was made known. Its value in medicine was early recognized by Prof. Ives, of New Haven, who employed it (in 1832) for the relief of pulmonary spasm. Its anæsthetic effect upon animals was first pointed out by Flourens; and when the news of the great American discovery reached Europe, J. Y. Simpson, at the suggestion of Waldie, took up the clinical study of chloroform, and, carefully noting its effect in fifty cases, gave his results to the world. Thus Simpson's name will always be associated with chloroform, as Morton's with ether.

At the outset there bade fair to be a decided rivalry between the two anæsthetics. European surgeons early adopted chloroform, and still adhere to it, in spite of the hundreds of sudden deaths that have followed its administration. Ether, first introduced in Boston, has never had a rival in

---

<sup>1</sup> J. Marion Sims, in *Virginia Medical Monthly*, May, 1877.

that city, and, with the exception of Prof. Gross, the prominent surgeons of Philadelphia and New York have always maintained a marked preference for ether. In the South and West there always has been a decided preference for chloroform, and such was also the case in the armies during the late war. During the last ten or fifteen years of his life Prof. Gross relied principally upon ether, and now in all the medical schools and hospitals of this city chloroform is rarely administered.

My experience with anæsthetics began with my appointment as interne to the Philadelphia Hospital. On completing my service I was placed on the clinical staff of Jefferson Medical College and given in charge of the chloroform. At the time of which I write, the surgical clinics were divided between S. D. Gross, Professor of Surgery, and Joseph Pancoast, Professor of Anatomy. The former almost invariably employed chloroform, the latter ether: thus the students had an opportunity during their course of study of watching the effects of the two agents upon hundreds of cases.

Of all the circumstances under which an anæsthetic may be administered, none is more trying than a public clinic,—trying to the one to whom it is administered, and trying to him who administers it. The former is denied the advantage of a quiet room with all undue excitement removed; the latter is expected as if by magic to have his patient fully anæsthetized the moment the operator is ready. Embarrassing delays frequently occur, and when these are met by reckless haste dangerous symptoms often arise.

I often wondered during my student days, and for years afterwards, why Prof. Gross employed a drug that was manifestly so dangerous,—for many hair-breadth escapes from death were witnessed by every medical class,—and only recently have I struck, as I think, upon the true solution of the mystery. In "The Principles of Surgery" Prof. Gross says, "I have never seen alarming symptoms but in three cases." Alarming symptoms seldom occurred in his private surgical practice,—at least I never saw him exhibit alarm in a private case. This was my own experience, and it is confirmed by others who assisted him for years. Prof. Gross was a teacher. He knew that the only safety in administering chloroform was in vigilance, and to impress this upon his class he took advantage of and magnified every seeming danger.

On retiring from the college service I made a comparative clinical study of chloroform and ether. Procuring a small graduated bottle with dropper, I found that constitutional effects could usually be obtained with twenty drops of chloroform, and artificial sleep with thirty. To secure the value of every drop, I used a small tin funnel, which conveyed the chloroform upon a diaphragm of muslin, from which it was instantly liberated; but when I attempted to produce anæsthesia with this contrivance and ether, I failed utterly. Patients would say, "Pour it on faster," and when inhaling it myself I found that I made no progress. I thus learned, what ampler experience has confirmed, that to produce anæsthesia quickly with ether a large amount of ether vapor must be rapidly liberated. A sponge permits

of a large surface for the evolution of ether, and could not be improved upon were it not that many of its loculi or cells are so small that the tendency is to keep the ether in its fluid state. To obviate this, I passed a bandage about three inches wide back and forth between the wires of a frame, and thus gained a large surface upon which a stratum of ether would be in contact with the air. I add below a description of the instrument which I presented to the medical profession in an article published in the *Philadelphia Medical Times*, October 14, 1874. I had no idea that the inhaler would ever come into general use, and I merely introduced it at that time to illustrate better the proper method of administering ether. Its very great popularity is my only excuse for introducing both it and the rules I then formulated for its use.

*Description of the Inhaler.*—It consists (Fig. 1) of a metallic frame, sufficiently large to cover the lower part of the face. The bars are nearly a quarter of an inch broad, leaving a quarter of an inch between each and its fellow. The spaces are made by a punch, which

FIG. 1.

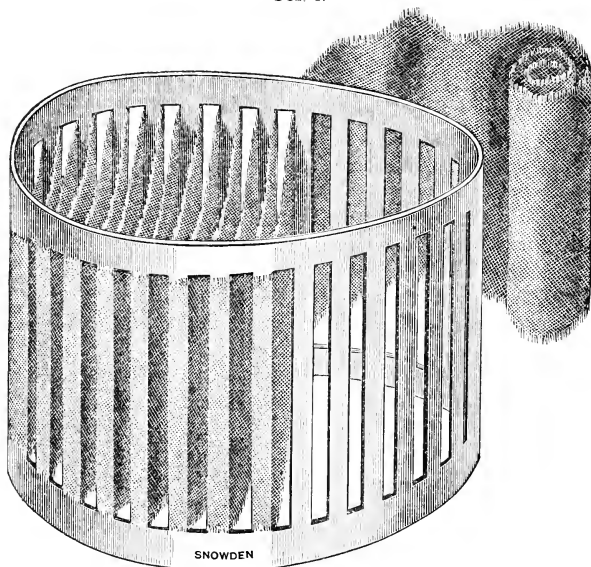

removes a section from a solid sheet of metal. It will thus be seen that there can be no danger of the bars giving way, as they would were they soldered upon a band.

Upon the left a bandage will be seen passed to and fro from bar to bar, dividing the instrument into parallel sections. This will be better understood by comparing Fig. 1 with Fig. 2.

The instrument is then completed by encasing in a leather hood (Fig. 2). I do not think the hood is any advantage, and much prefer a folded newspaper constructed to take its place. After using, the hood should invariably be removed.

The advantages of this mode of construction are,—

1st. It gives the patient (Fig. 2) the freest access of air. It is a mistake to think that air must be excluded. All that is necessary is that *the air should be saturated with the vapor of ether.*

2d. It affords a series of thin surfaces upon which the ether can be poured, and from which it will almost instantly evaporate. In this respect it differs from the sponge, which

FIG. 2.



retains the ether in a fluid state much longer. Should the bandage become soiled, a new one can be inserted in a few minutes.

3d. By leaving the instrument open at the top the supply can be kept up constantly, if desired; and, as *ether vapor is heavier than air*, there is no loss by not covering it. The top should never be covered.

*Mode of using the Inhaler.*—1st. Place a towel beneath the chin of the patient, as experience has taught that a towel should always be within reach in administering anæsthetics.

2d. Place the instrument over the face, covering the nose and chin, and let the patient breathe through it before any ether is applied. This will convince him that he is not to be deprived of air.

3d. Begin with, literally, a few drops of ether: this will not irritate the larynx. Add, in a few seconds, a few drops more, and as soon as the patient is tolerant of the vapor increase it gradually to its fullest effect.

4th. When the patient is fully influenced, it is well to add a few drops at short intervals, and thus keep up a gradual anæsthetic effect.

*The Advantages of the Inhaler.*—1st. It presents a large surface for the liberation of ether vapor. The partitions are made of thin bandage, and the air coming to both sides of each layer sets the ether vapor free more rapidly than is possible in the use of a towel or sponge.

2d. It is open at the top, and the ether can be added *constantly*, if desired, and in small quantities without removing from the face. The sponge and towel both require removal, and the ether is usually poured on them in quantities.

3d. The ether vapor falls by its weight, as it is heavier than the air; and as the instrument fits the face the patient gets the full advantage of it.

4th. It does not cover the patient's eyes,—does not terrify him, and he often passes under its influence without a struggle.

5th. By its proper use the laryngeal irritation may be wholly avoided, the anæsthetic effect will be as easily gained as is possible with the use of ether, there will be a great economy of ether, and great comfort will be secured to the patient.<sup>1</sup>

With this I could in the average case produce anæsthesia in from five to ten minutes, but it required from ten to twelve times as much ether in bulk as of chloroform. It will be noticed that I did not employ any apparatus by which I could measure absolutely the quantity of the anæsthetic inhaled, or graduate its strength. Still, allowing for waste, I found that I could accomplish full and complete anæsthesia with as small a relative quantity as was claimed for scientific inhalers, and as speedily. The full effect of chloroform could often be gained in from three to six minutes, and usually with less than a drachm, and nothing better than a single layer of a towel or napkin could be desired. With ether the chief difficulty was to produce ether vapor rapidly enough, and I occasionally found cases which the most concentrated vapor would but partially anæsthetize.

Every surgeon has been annoyed by the tardy effects of ether, and would have abandoned it for chloroform were the latter as safe. To render chloroform safe and ether more effective a great variety of inhalers have been invented by the medical profession; but it should ever be borne in mind that safety, the great desideratum, does not lie in inhalers. Through their use it has been found that only a five-per-cent. admixture of chloroform with atmospheric air can safely be employed, and yet death has followed the use of this safe quantity in a Snow's inhaler. The pertinent query is, if a five-per-cent. admixture will produce such profound anæsthesia as to permit of a capital operation without reflex manifestations, will not the thoughtless continuance of the vapor produce coma and death?<sup>2</sup> It is possible with the use of a scientific inhaler to know just how much of the anæsthetic has been taken, but no instrument has ever yet been contrived to measure the effect upon the patient.

When chloroform is administered on a towel, the latter is usually folded into eight layers. Some teach that "it is not necessary to begin with more than a drachm," while others recommend enough to moisten the towel for a space about the size of the palm, the precise quantity used being a matter of no consequence whatever. How such instructions are consistent with safety I do not understand. In all such administrations there is a needless waste if the towel is held at a distance from the face, and a criminal recklessness if it is held close to the face. Instead of taking a folded towel, I take but a single layer, and then if I drop on more than is necessary it is promptly dissipated. With a single layer there can be no retention of the anæsthetic, and hence it must be constantly renewed. I do not think I am

---

<sup>1</sup> Dr. George R. Fowler published in *The Medical Record*, July 2, 1887, the description of an instrument to which he has given the name of "A Folding Allis's Ether Inhaler." It is constructed on the principle of Fig. 1, but is square instead of oval. When packed for transportation it is nearly flat. Space will not permit of an illustration.

<sup>2</sup> Holmes and Hulse, vol. iii. p. 598.

over-confident when I state that one thousand administrations of chloroform, without distinction as to age or sex, could be accomplished with less than one thousand drachms of the drug, and in each instance a degree of anæsthesia be obtained sufficient for the inception of the gravest surgical undertaking. A few large, powerful adults might require more than a drachm, but in the majority of men and women and invariably in children the amount would be less. When I administer chloroform and accomplish the desired effect in four minutes, when I consider that in this time there have probably been but sixty full respirations and that I have used but sixty minims of chloroform, then it is that I realize the value of a minim of the agent; and I cannot but dread the dissemination of a doctrine that would dispel all fears of its deadly action. Scores of witnesses have declared that death occurred after a fresh supply of chloroform was put upon the towel, and, for one, I do not doubt that in persons fully anæsthetized a single deep inspiration from a saturated towel has produced death, since a single minim properly administered has definite anæsthetic value.

I have but little to say in regard to the administration of ether. In most cases there will be no difficulty in administering it upon a folded or funnel-shaped towel or sponge. Unlike chloroform, the ether should be sprinkled on freely, but, as with chloroform, it is better to sprinkle it on at short intervals than to saturate the towel. If the administrator watches his opportunity he can sprinkle on fresh ether in the interval between expiration and inspiration, and thus not lose a single inhalation. In some instances the vapor is irritating to the larynx. In such cases it is humane, to say the least, and a saving of time, to suspend the administration and permit the patient to take one or two deep inhalations of pure air.

With females and with most men anæsthesia can be readily accomplished with ether. But it occasionally happens, as I have already intimated, with children as well as with adults, that ether seems to have scarcely any anæsthetic effect. The difficulty with this class is, they do not breathe; *i.e.*, their breathing is so shallow that the minimum of respired air consistent with comfort is inhaled. This class will be no more under its influence in ten minutes than after the first inhalation. To produce anæsthesia in them with ether, resolute, determined action is necessary. They must be compelled to breathe, and to breathe deeply. The towel or sponge being fully saturated with ether, hold it a little above the mouth and nose, but so tightly about the face that no air that is not saturated with ether can be respired. As soon as this is done, a struggle for supremacy will begin, for which the anæsthetist must be prepared. With the struggles come deep respirations, and often in a single minute the struggles cease, the characteristic deep respirations of beginning etherization are heard, and the victory is complete. As soon as the deep respirations are noticed and the struggling abated, the ether must be administered with more care. It is only to overcome, to gain the mastery, that such measures are at times required, and as soon as the mastery is obtained the further effect must be continued as in

other cases. It will be asked, "Is it safe to administer ether in this manner? Is there no danger of suffocation? Have not persons been suffocated in this way?" I answer, I have never witnessed a single alarming symptom, nor a single case in which following this struggle for supremacy it was necessary to discontinue the ether and resort to efforts at resuscitation. Ether administered in this way—or, in fact, in any way—must be administered with judgment: the effect must be watched, and when the effect is gained, no matter how, or how quickly, no intelligent or watchful administrator will increase its influence.

Some physicians, annoyed by the frequent delays of ether, and unwilling to incur the risks of pure chloroform, have thought to improve upon both by mixing them. A mixture of one part of chloroform and two parts of ether was at one time extensively used, but has been abandoned as unsafe. For my part, I consider it far more dangerous than pure chloroform, and the reason why I so fear it is that it is regarded as being as safe as ether while it has five times the latter's anæsthetic potency.

In many cases, and almost invariably with children, I begin with chloroform, and, having gained the first anæsthetic effect, transfer the patient to my assistant, who administers ether.

Whatever anæsthetic is employed, as soon as the requisite degree of anæsthesia is obtained, the effect should not be increased, but should be steadily maintained by a constant supply of the minimum quantity possible. To establish and maintain complete anæsthesia—neither carrying the patient beyond the limit of safety nor suffering him to return to partial consciousness—is an accomplishment worthy the ambition of every practitioner of medicine and surgery.

In the administration of anæsthetics to children the same series of phenomena are noticed that occur in adults. The majority of children cry and struggle after the first few seconds, and, as this is attended with deep and rapid inspirations, the anæsthetic effect is, as a rule, rapidly obtained. The struggling imperatively demands a strong and resolute assistant, one who is familiar with the effects of the agent and whose sympathies are not a matter of sentiment. In many instances the anæsthetic irritates the bronchial mucous membrane. Mucus is poured out rapidly and in large quantities throughout the entire bronchial tract, and often to a distressing degree, respiration is embarrassed and accompanied with large moist râles, the lips become livid, the face is cyanosed, and all the signs of non-oxygenation of the blood are present. Under these circumstances the only relief the little sufferer obtains is from incessant spasmodic coughing. To withdraw the anæsthetic entirely in such cases while a painful surgical operation is in progress is manifestly undesirable, but prudence will hold the anæsthetic effect on the confines of consciousness. I have often witnessed this condition, and believe it to be a more frequent accompaniment of ether than of chloroform. I have never witnessed any serious results from this condition.

Although I have stated that the majority of children resist the administration of anæsthetics, my own experience is that the opposition to ether is much more decided than to chloroform. In cases where I have been required to complete a painful surgical procedure, I have had the little patient plead for chloroform, especially if it has once experienced its effects. The question often arises, can a person be put under the influence of an anæsthetic during sleep? I cannot speak from experience with ether, or in adults, but I am positive that chloroform can be administered to a sleeping child without its waking to consciousness.

Although chloroform is dreaded by the profession generally, the popular verdict being manslaughter when a death occurs from its administration, still my decided preference in every case, and especially in children, is for that anæsthetic. When I say especially in children, I do not wish to be understood as endorsing the oft-repeated assertion that "you cannot kill a child with chloroform." The supposed immunity enjoyed by children is not borne out by statistics or clinical practice. Deaths have occurred in early life, and would be more frequent were operations as common in childhood as in adult life. The real source of safety is the chloroformist's instinctive caution. I shall never forget the mortification I felt, when in charge of the anæsthetic in the clinic of the elder Gross, at not being allowed to administer to an infant that was about to be operated upon. In this instance Dr. F. F. Maury, the chief clinical assistant, took a single layer of a towel and, cautiously sprinkling on a few drops of chloroform, shook it, to guard against excess, and then held it first at a distance from the infant's face, to avoid frightening it, and, gradually bringing the agent nearer the face, as the little patient became accustomed to it, soon obtained the desired effect. Wherein, I ask, lay the safety in this single instance? and the ready response will be, "In the cautious administration." In marked contrast to this were the haste, precipitancy, and I might almost say recklessness with which at times it was given to adults. Only a few clinics previous to the one mentioned, I was administering chloroform to a consumptive female from whom a tumor was to be removed, and, as she came slowly under its influence, Dr. Maury took the two-pound bottle of chloroform and dashed on, possibly, a half-ounce. The effect was decidedly too great, and but for the timely and energetic action of Prof. Gross, whose quick perception took in the situation, a fatal issue might have been the result. Wherein lay the danger in this case? Certainly not in the chloroform, but in its maladministration.

When, however, I commend chloroform, I always do so on the sole condition that it shall be properly administered. Unless the anæsthetist can be made to realize that each minim of chloroform has positive anæsthetic value, and unless he can devote his entire attention to the condition of the patient, he is unfit to handle it; and for this reason, and no other, I endorse the popular verdict that ether is the safer anæsthetic.

It occasionally happens that an infant requires an anæsthetic within a



few hours after birth. Clinical experience has shown that so grave an operation as a laparotomy or a herniotomy can be safely undertaken at this tender age. I have never administered an anæsthetic under these circumstances, but should not hesitate to give either when required. Under such circumstances I should strongly recommend the course of Dr. Maury already referred to,—namely, to add a few drops of chloroform to a single layer of a napkin or handkerchief, and begin the administration by holding it first at a distance of six inches from the face, and gradually approach the face as the first irritating effect passed off.

In membranous or spasmodic laryngitis the administration of, so to speak, an atmosphere of chloroform has in my hands had a magical effect. I have entered the room and found the father carrying his struggling child, cyanosed and gasping for breath, and, following the movements of the father as he walked about the room, have held a little chloroform above the child's face. In a few moments the struggling ceases, the color returns to the lips, the patient becomes quiet, and is in as advantageous a condition for an operation as could be desired. I have heard surgeons, speaking of the imminent danger under these circumstances, declare that there was no time to administer an anæsthetic, and that a moment's delay would have been death. I do not wish to put my own judgment against the experience of any surgeon, but I am strongly of the opinion that spasm is an element of great importance, and often the immediate cause of death.

In a neighboring city a child, while playing with a piece of broken china in its mouth, passed the fragment into the larynx. Physicians were summoned, and while efforts at extraction were made the child was suffocated. The foreign body lay in the larynx, but did not completely close it: had it done so, the child would have died as suddenly as from drowning. As it was, there was time to summon physicians and time for fruitless attempts at extraction. Under such circumstances, chloroform would have made the larynx tolerant of the foreign body until a surgeon could have been obtained, when laryngotomy might have rescued the child from impending death.

Anæsthetics are often administered in early childhood with a view of making a positive diagnosis in hip-disease. The painful nature of the affection often precludes the possibility of handling the joint, and hence a resort to ether or chloroform. Such a procedure for mere purposes of diagnosis I believe to be unwise and unsurgical. After full anæsthesia the fixation of the hip often entirely disappears, and the unwary examiner pronounces the joint sound, and recommends a course of action as unwise as his diagnosis is incorrect.

The elder Gross almost invariably operated upon hare-lip in early infancy without an anæsthetic, and some, fearing lest blood should find its way into the larynx, have in like manner attempted staphylorrhaphy without it; but this course is, I think, seldom followed by surgeons nowadays. For myself, I have never witnessed any unpleasant symptoms from opera-

tions within the buccal cavity. Tonsillotomy is usually performed with the consent and co-operation of the patient, but there is no danger in performing it with the child recumbent or semi-recumbent and under the influence of an anæsthetic.

Persons of limited experience in the use of anæsthetics often ask for information on the following points.

1. Is it safe to administer them in cardiac or pulmonary diseases, or to persons suffering from shock or from loss of blood, or prostrated by long and wasting disease? And, if so, which is preferable?

2. Can they be safely administered to the very young and to those of advanced age?

3. How long is it safe to continue the anæsthetic effect at one time?

4. Are repeated administrations prejudicial to health?

5. Have permanent bad effects ever been traced directly to anæsthetics in surgical use?

6. Are there circumstances under which ether is preferable to chloroform, and *vice versa*?

Cardiac disease, though relatively infrequent, is possible in all its phases in infancy and childhood. With the exception of interstitial changes, the accompaniment of advancing years, the child's heart does not differ in its physiological actions from that of the adult. What is true of cardiac is true also of pulmonary affections: every type of disease may be found in infancy and childhood. It behooves the administrator of the anæsthetic to discriminate carefully as to the character, extent, and depressing influence of the disease in question. So, too, in shock, anæmia, prostration from loss of blood, etc. In such conditions the solution of the problem hinges not on the state of the system, but on the urgency and magnitude of a surgical disorder, whose attention imperatively demands an anæsthetic, and without which the surgical procedure would be impossible. When such embarrassing circumstances arise, the only resource lies in the judicious handling of the anæsthetic. For the comfort of the anæsthetist, I will say that death seldom follows the administration under these conditions, the long list of casualties showing no disease whatever to which the fatal result can be attributed.

Under these circumstances, shall ether or chloroform be given? Ether is said to be a cardiac stimulant or excitant. That this is so in the early stage of anæsthetization is of little practical moment. The fact that it is not a prolonged stimulant, the stimulation not continuing after the full effect is obtained, places it practically upon a par with chloroform. Both are cardiac depressants when pushed beyond the proper limit of anæsthesia. In the above-mentioned conditions the majority of surgeons would prefer ether, and when I give an opinion in favor of chloroform I shall be asked to defend it. My reasons therefore are—

1. It requires only *one-tenth* the amount of chloroform to produce the desired effect, and therefore the system does not become so saturated with

it, and there is not subsequently such profound and long-continued nausea and distaste for food.

2. Chloroform is a much more manageable agent than ether. I regard each minim as possessing anæsthetic value. Hence I feel that with it I can control the anæsthetic effect with great precision.

Both these reasons are of the utmost importance when an anæsthetic is to be administered to one in an exceptionally feeble condition.

I have already spoken of anæsthetics in the tender years of infancy, and given detailed instruction upon that head. Man is never twice a child physically. The succulent, elastic, rapidly-developing condition of childhood contrasts strongly with the shrinkage, attenuation, and aridness that are consequent upon old age. Hence the conclusion that, if care is necessary in infancy and youth, it is of fourfold imperativeness in decrepitude.

The length of time that one may safely inhale an anæsthetic will vary with the circumstances of the case. When there is much loss of blood, when the shock, as in amputation of the thigh, is necessarily great, when the patient is almost bloodless at the time the operation is undertaken, then there must be a minimum amount of the anæsthetic, and the greatest possible despatch. Despatch—not reckless haste—is too little appreciated in these days of anæsthesia. I fear there are many victims to what is now boastfully styled deliberation. The pendulum has swung to the other extreme. The time was when students took out their watches to count the seconds of an operation. Now they may go out to lunch, and stroll back to the finish!

As to repeated administrations, they are seldom required in infancy. In childhood and youth they are as well borne as in adult life. I have never witnessed permanent bad effects from the use of chloroform or ether.

Are anæsthetics ever inadmissible? Surgeons who rely upon chloroform use it for nearly everything, just as others employ ether. There are some points that should never be lost sight of. When the cautery is required, do not bring the heavy ether vapor near it. I have seen a conflagration on three occasions, and, strange to say, in every instance it occurred to persons long familiar with the inflammable nature of ether and ether vapor. When the erect posture is required, then use ether, not chloroform. Some fear lest blood may run into the larynx during operations on the mouth and nose. I have never witnessed an alarming symptom from strangulation on these occasions. Vomiting will, of course, follow, but this is a very common occurrence with anæsthetics.

Flagg demonstrated as early as 1848<sup>1</sup> that it was possible to etherize a patient sufficiently for the removal of a scirrhus breast, without reflex manifestations or consciousness of pain, and yet retain a drowsy consciousness of everything passing, and ability to understand and give correct

---

<sup>1</sup> Medical Examiner, No. xxxvii., January, 1848; also "Ether and Chloroform," by J. F. B. Flagg, Lindsay & Blakiston.

replies to questions asked during the entire operation. The experience of practical surgeons is that the graver the operation the more complete the anæsthesia should be, since there is a corporeal suffering or shock from an operation when too little is administered, that can be greatly lessened by full anæsthesia.

Packard has availed himself of the first loss of consciousness to open abscesses, reduce a luxation, etc. The patient is told to raise the arm and hold it up while inhaling, and when it becomes unsteady and drops, the abscess is opened, and the patient returns promptly to consciousness. Of course, if a further anæsthetic effect is desired, it can be readily obtained. It requires an experienced surgeon to know when a few seconds will suffice for an operation.

#### SUGGESTIONS FOR THE ADMINISTRATION OF ANÆSTHETICS.

1. If the patient has taken opiates for the relief of pain, the amount should be carefully inquired into. I have never known any unpleasant effect to occur in infancy or childhood, but I have repeatedly witnessed profound coma, in one instance a narrow escape from death, and in one death, which was clearly the result of the enormous amount of morphine administered after an injury. In these cases the drug was manifestly unabsorbed, owing to the degree of shock and pain, the patient being apparently unaffected by the morphine and calling continually for more, but absorption took place during the exhibition of the anæsthetic, and dangerous and even fatal narcosis followed.

2. The condition of the heart, lungs, and kidneys should be ascertained prior to the operation. All discussions of the safety of administration, etc., should be settled beforehand, not at the time of administration. If this has been neglected, it should be done before administration, as ignorance on this point is unfavorable.

3. The patient, if robust, should be denied food and drink for six hours before inhaling. If feeble, hot beef tea, or peptonized food, should be given an hour before the operation. In infancy and childhood no rules are obeyed. In childhood do not restrict the food, but regulate it. Mushy foods are more easily and safely vomited than meat, apples, and chestnuts.

4. All restrictions in the clothing that will embarrass respiration should be removed. Look to the neck and waist. See that everything is loose: take no patient's word for it.

5. All parts of the body, especially in infancy and in the weak and aged, that do not require exposure should be covered and shielded against cold. This simple injunction is too often disregarded.

6. Always inquire about false teeth. Make a habit of it. It will do no harm to ask the question, even if it be done in sport. Neglect to form the habit may lead to oversight and disaster.

7. Basins and towels should be in readiness before the administration is begun. Vomiting is likely to occur in every case, and not to provide for

it is certainly inexcusable. Vomiting occasionally occurs before the full effect of the anæsthetic is obtained. More frequently it occurs on returning to consciousness. I have often remarked that patients who secreted and swallowed much saliva during the inhalation invariably vomited as the effect was passing off.

8. Forceps, tenaculum, mouth-gag, tongue-depressor, ammonia, brandy, and pounded ice should be placed where they can be reached.

9. The administration should be begun in retirement. No conversation. No busy getting things ready. No fussy doctor to hold the pulse. Assuring words from the administrator in a low tone will act as a diversion and be of advantage.

10. When the patient is fully influenced, and not before, let an assistant hold the pulse. This of all precautions is the least essential; but, if it be required, omit it while the patient is conscious.

11. The working anæsthetic zone is usually preceded by deep, heavy breathing. As soon as this is heard, the desired effect has been reached, and a more profound effect should be guarded against. The administrator should hear every breath, but he should hear nothing else. He should be deaf to all general conversation. Inconsiderate by-standers will ask him questions: these should be rebuked by silence.

12. The effect produced is best known by the character of the breathing. One ear is worth a dozen eyes. Were all anæsthetists blindfolded, there would be fewer deaths.

13. When the eyes are used, let them be used to the advantage of the patient, and not to the advantage of the operator or his assistant. So long as the lips have a healthy color, the capillary circulation is good. When they become livid and the face ashy pale, proceed with caution. Watch the lips,—not the steps of the operation.

14. When the working anæsthetic effect is reached, hold it by repeated additions of a minimum quantity of the anæsthetic.

15. To hear every breath and to keep the patient in a safe but unconscious state demands the fullest attention of the administrator. His sole duty is with the anæsthetic. If the surgeon has failed to supply himself with proper assistance, if an artery spurts and no one is at hand to attend to it, if any emergency arises that could not have been foreseen, leave these with the surgeon. Your duty is wholly with the anæsthetic.

16. When the operation is over and the patient is to be prepared for his bed, do not leave him on any account. Don't abandon the ship as she is entering the harbor. See your patient safely in bed, either fully conscious or in gentle sleep, and leave others to look after other matters.

It is a matter that denotes healthful progress that, in our large cities, a skilled, experienced assistant is usually secured to administer the anæsthetic. Undergraduate medical assistants and nurses are now detailed to duties better suited to their capacities. It is also to be noted that the anæsthetist is now compensated, though meagrely, for his services.

## ACCIDENTS FROM ANÆSTHETICS.

An "overdose" often occurs through ignorance or want of attention on the part of the administrator. I attribute the "clean record" of those who have been life-long friends of anæsthetics to their personal vigilance. Prof. Gross never put absolute trust in any assistant.

One of the most alarming symptoms, especially to those who have had little experience, is the sudden stoppage of respiration, as if through closure of the larynx. The patient struggles, becomes livid, but cannot inhale. In such a case, if the tongue is drawn forward and depressed at its base, air will promptly enter the lungs, and all danger will vanish. The danger in these cases is often more apparent than real. It is not always safe to put the finger in the mouth to depress the tongue. The jaws have closed on many a hand with a will that proved that danger was far off.

When the anæsthetic has been pushed too far, when too profound an effect has been obtained, when symptoms of coma or syncope arise, then the danger is far greater. In this condition the tissues are poisoned with the agent: blood, heart, brain, lungs,—all are saturated. For this class Nélaton suggested depression of the head and elevation of the lower part of the trunk, or, as some have termed it, "hanging the patient up by the heels." The rationale of this course is that the blood impinges on the brain, from gravity, and stimulates centres that a feeble or pulseless heart could not reach.

Cold or hot water dashed on the exposed chest, and slapping the chest with a towel dipped in water, either cold or hot, are valuable means for provoking reflex action. Ammonia held near the nostrils acts as a restorative. In severe cases the trachea has been opened and the lungs filled by means of a bellows.<sup>1</sup> Insufflation (mouth to mouth) has, no doubt, proved of advantage in some cases. Venesection in desperate cases has been resorted to.

A study of the accidents, the modes of death, and the efforts at reanimation has led me to put little confidence in restoratives. Most of those resuscitated reacted promptly,—within a few seconds, certainly within a minute or two. I do not think I ever saw dangerous symptoms continue for one whole minute. I have seen the patient profoundly influenced and have watched the effect for many minutes with anxiety, but in all these cases the heart and lungs were still in action. Unless the heart and lungs resume their functions promptly, I believe death always follows. I do not believe a life has been saved by tracheotomy or persistent artificial respiration—by Silvester's or Howard's methods—if five minutes have passed without good results. I make these statements not to discourage any one in the use of restoratives, but—

---

<sup>1</sup> This extreme measure has not been crowned with success, probably because it is delayed until after death has taken place.

First, to warn persons against inattention in giving anæsthetics,—to caution them about carrying their patients beyond prudent limits.

Second, when danger arises, every second is a lifetime : prompt efforts are the only efforts that have ever succeeded.

There is one safeguard, which consists in cutting off by means of a tourniquet the circulation of some part of the body, as, for instance, that of the entire thigh and leg, and keeping this blood free from toxic influences during the operation. When this is over, the tourniquet is removed, fresh, pure blood—as by auto-infusion—seeks the heart and brain, and reanimation is rapid and complete. This precaution has not yet been generally adopted, and no accidents for or against it have been reported. It cannot be urged as necessary if due caution is exercised, but it would be a most timely resource in case of overdose.

#### PATHOLOGY.

Autopsies have never revealed anything that could justly point to the anæsthetic. The true cause of death in the majority of cases is toxic agency, and this the microscope cannot reveal. A few cases of asphyxia have been demonstrated. Some deaths attributed to anæsthetics are mere coincidences. The “fatty heart” is alleged to be present in most cases, and is the sole comfort of the survivors.

PART IV.  
DISEASES OF THE OSSEOUS SYSTEM  
AND OF THE JOINTS.

---

CONGENITAL ABNORMALITIES OF THE  
EXTREMITIES.

BY THOMAS R. NEILSON, M.D.

---

As indicated by its title, this article includes within its scope only certain abnormal conditions of the extremities which either are present in fact, or the tendency to which exists at the time of birth. In the limited space at his disposal, the writer has found it impossible to enter into a purely scientific or teratological discussion of the subject, and has therefore endeavored to deal with its several subdivisions more from a practical point of view.

While a considerable proportion of the instances of congenital abnormalities are of such a nature as to be of little interest to the surgeon except as anatomical or pathological curiosities, there still remain a much greater number which possess a practical interest for him, inasmuch as operative interference or the selection and adjustment of an apparatus may be demanded for their improvement or cure.

The origin and causes of malformations afford a fertile field for investigation. The obstacles to pursuing systematically such a study are, of course, very great, but, through the aid of our knowledge of embryology and comparative anatomy, many of them have been overcome. In early times, when superstitions of all kinds ran rife, it is not to be wondered at that deformities or monstrosities were attributed to such causes as judgments or visitations from the Creator, the wrath of heathen gods, or the evil influences of witches. A theory which has long existed, and which has still many adherents in the profession as well as among the laity, is that in some



cases these deformities result from a profound impression made upon the mother's mind during gestation,—maternal impressions. In regard to this, while it is very obvious that through the influence of mental or nervous shock to the mother the general condition of the fœtus may suffer, and even its death ensue, there is no ground, other than pure theory, for assuming that because the mother has been shocked by the appearance of a malformed member belonging to some individual whom she may have encountered, she will give birth to a child similarly malformed. In many cases, if the circumstances be inquired into, it will be found that the occurrence of such a shock took place at a period too late in the development of the fœtus for it to have had the influence attributed to it; and nearly always it is recollected or spoken of *after* the birth of the child and the discovery of the existence of an abnormality. In many instances, too, the likeness of the deformity to the object which produced the shock in the mother is purely fanciful, and fades into nothingness before a careful examination of the part.

The origin of all congenital deformities will be found to fall under one or other of the four following heads:

1. Excess of development,—including supernumerary limbs and digits.
2. Arrest of development,—whole or partial absence of extremities.
3. Mechanical injuries by amniotic bands and the umbilical cord,—distortions of the extremities (club-hand and club-foot) and intra-uterine amputations.
4. Original fault in the germ, either ovum or spermatozoön,—hereditary malformations.

#### CONGENITAL HYPERTROPHY OF THE EXTREMITIES.

This must be classed as a comparatively rare abnormality. It consists in an excessive growth of all the parts which make up an extremity. The affection is usually unilateral, one extremity alone, or part of it (and in this case its lower end), being involved. The fingers and toes, in fact, afford the most numerous examples. The subject has engaged the attention of various writers from time to time, contributions to its literature having been made by Trélat and Monod,<sup>1</sup> Battersly,<sup>2</sup> and others, and more recently by Anderson.<sup>3</sup>

The origin of the condition cannot be certainly stated, nor can it be always asserted, save when the digits are affected, that it is present in any marked degree at the time of birth. It seems probable that the cause lies in an affection of the nerve-centres governing the nutrition and development of the part; but this has not been demonstrated. Heredity has nothing to do with it.

The disease is progressive, sometimes rapidly so, and, as has been said, implicates all the normal structures of the member. The bones are en-

---

<sup>1</sup> Archives Générales de Médecine, 1869, vol. xiii.

<sup>2</sup> Dublin Medical Press, vol. xxiii.

<sup>3</sup> St. Thomas's Hospital Reports for 1881.

larged, markedly so at the epiphyses; the ligaments are increased in thickness; the muscles and tendons are excessively developed; and as to the blood-vessels, while the arteries may not be affected to a noticeable degree, the occurrence of varicose veins and aneurismata is frequent; the lymphatics are said to be prone to dilatation; the nerves do not appear to be altered. The subcutaneous fat is increased in thickness, lipomatous tumors being quite common in hypertrophied limbs. The disease is usually painless. The temperature of the limb is generally unaffected, but cases have been reported by Reid<sup>1</sup> and by Trélat and Monod (*loc. cit.*) in which it was somewhat above the normal. The degree of mobility and usefulness of the limb varies: in some cases it is quite good, in others moderately restricted, and in still others the part is entirely useless. Fingers and toes, when affected to any considerable extent, are apt to be distorted or bent in one direction or another, usually laterally or backward, the distortion being explained by Curling as due to tension of the displaced extensor tendons which have not elongated proportionately to the length of the digit.

Although the deformity is usually unilateral, cases have been recorded by Curling<sup>2</sup> and by Annandale<sup>3</sup> in which it was bilateral. In these instances, however, it was limited to the digits, the remainder of the limbs being normal.

The degree which the hypertrophy may attain is exemplified in the two following cases. In the first case, reported by Dr. William Osler,<sup>4</sup> the right upper extremity was affected.

The patient was a girl eight years of age. Comparative measurements showed the following excesses in favor of the affected limb: half of chest, four centimetres larger; humerus, three and one-tenth centimetres longer; circumference of arm at biceps, extended, two and nine-tenths, flexed, four and four-tenths centimetres greater; forearm, four and two-tenths centimetres; wrist, three and five-tenths centimetres; hand, four and six-tenths centimetres; middle finger, five millimetres; index finger, seven millimetres. The muscles of the arm, especially the biceps, were well developed, as were also those of the forearm, and the muscular power of the limb was greatly increased. The wrist was thick, the hand square, thick, and short, the fingers small in proportion, and kept strongly flexed, all but the middle one having the motion of extension.

In the other case, recorded by Dr. T. W. Hurley,<sup>5</sup> the malformation was limited to three digits,—the thumb and the index and middle fingers of the right hand.

The patient, a child thirteen years old, exhibited at the time of birth some enlargement of the affected fingers, and their relative size had continually increased up to the time of observation, when the measurements were found to be as follows: index finger, seven inches in length, five and three-fourths inches in circumference; middle finger, nine inches long,

<sup>1</sup> London and Edinburgh Monthly Journal of Medical Science, 1843, vol. iii.

<sup>2</sup> Medico-Chirurgical Transactions, 1845, vol. xxviii.

<sup>3</sup> The Malformations, Diseases, and Injuries of the Fingers and Toes, Philadelphia, J. B. Lippincott & Co., 1866.

<sup>4</sup> Journal of Anatomy and Physiology, London, 1879, vol. xiv.

<sup>5</sup> American Medical Bi-weekly, Louisville, 1878, vol. ix.

and about the same in circumference as the index; thumb proportionately enlarged. The diseased digits were amputated, and their condition was shown to be due to an affection—"obliteration"—of their lymph-channels.

Fig. 1, from Annandale, shows an instance in which the middle and index fingers were hypertrophied, the patient being a child three years of age, and the deformity having been noticed at birth.

FIG. 1.

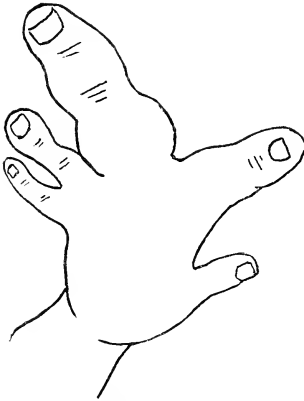

(After Annandale.)

True hypertrophy must be distinguished from an increase in the size of a member due to excessive growth of its cellular and adipose tissues. In the latter the muscular, ligamentous, and osseous structures are unaffected.

**Treatment.**—Where a whole limb is hypertrophied, the prospect of benefit from treatment is not encouraging. Pressure has been tried, but usually without success. Mr. Holmes, however, in his "System of Surgery," mentions one instance in which the persistent use of an elastic stocking was followed by a diminution in the size of an hypertrophied leg. When the

lower extremity is affected, and active interference does not seem to be called for, the increase in length of the hypertrophied limb over that of the normal one should be compensated for by the use of a thick-soled and high-heeled boot upon the latter. In either extremity, if the disease progresses to such an extent as to render the member useless or a burden to the individual, or if, contrary to the general rule, there be persistent and unbearable pain, the case will be one for operation.

The first resource lies in ligating the main artery of the limb. Mr. Christopher Heath<sup>1</sup> has reported a case of hypertrophy of the leg successfully treated by ligation of the external iliac artery. If the deformity be of an extreme degree, it is not likely that this operation will be rewarded with success, and the only resource is amputation.

For hypertrophied fingers and toes the only treatment to be recommended is amputation, care being taken to remove along with them the heads of the metacarpal or metatarsal bones if they are involved in the affection. Care must also be taken that the operation does no damage to the neighboring normal digits. If it be impossible to remove the affected digits without inflicting injury upon the healthy ones, the operation should not be undertaken.

<sup>1</sup> London Lancet, 1877, vol. ii.

## CONGENITAL DEFICIENCIES.

The class of malformations included under this head is by no means a small one, and includes defects of development varying in extent from the absence of a portion of a single digit to the lack of one or more entire limbs. While often confined to one extremity, the deficiency is not seldom observed to be bilateral, and cases are recorded in which all the extremities of the individual have exhibited some failure of development, and in at least two recorded instances, one reported by Hardy<sup>1</sup> and one by Hare,<sup>2</sup> both upper and both lower extremities were entirely wanting. Cases in which both upper extremities were absent have been met with by T. Smith,<sup>3</sup> by Ramon,<sup>4</sup> by Gee,<sup>5</sup> and by Curran.<sup>6</sup> Barwell<sup>7</sup> reports two cases in which both arms were truncated and bore upon their ends rudimentary hands.

In his comprehensive work entitled "*Histoire générale et particulière des Anomalies de l'Organisation chez l'Homme et les Animaux*" (Bruxelles, 1837), Isidore Geoffroy Saint-Hilaire has divided malformations of the extremities due to defect into three classes:

1. "Ectromélie" (from the Greek *ἔκτρωμα*, "an abortion," and *μέλος*, "a member"), the condition in which the extremities, either upper or lower, are entirely absent or nearly so. The term applies only to cases in which the deficiency is the result of arrest of development, not to intra-uterine amputations. Individuals thus deformed are designated "ectromèles."

2. "Hémimélie" (*ἡμισυς*, "half," and *μέλος*), the condition in which the limbs are very incomplete, terminating as stumps, and possessing either no digits or very imperfect ones. Persons presenting this abnormality are called "hémimèles."

3. "Phocomélie" (*φώχη*, "a seal," and *μέλος*), the monstrosity in which the limbs are absent and the hands and feet are joined immediately to the trunk, the subjects of the deformity being named "phocomèles."

A considerable number of instances of partial deficiency—*i.e.*, the absence of one or more bones, or portions of them, of the upper extremity—are to be found in the literature of the subject. Cases in which the radius was absent have been reported by Swaagman (double),<sup>8</sup> Ledru (double),<sup>9</sup> Letulle,<sup>10</sup> Hodge,<sup>11</sup> Gruber,<sup>12</sup> Erichsen,<sup>13</sup> Parker (one case double, another

<sup>1</sup> Baltimore Medical and Surgical Journal and Review, 1834.

<sup>2</sup> Transactions of the Pathological Society of London, 1858-59, vol. x.

<sup>3</sup> Transactions of the Clinical Society of London, 1873, vol. vi.

<sup>4</sup> Bulletin de l'Académie de Médecine, Paris, 1842-43, vol. viii.

<sup>5</sup> Liverpool Medico-Chirurgical Journal, 1859, vol. iii.

<sup>6</sup> Medical Press and Circular, London, 1887, vol. xliii.

<sup>7</sup> Transactions of the Pathological Society of London, 1881, vol. xxxii.

<sup>8</sup> Archiv f. Path. Anat., 1865, vol. xxxi.

<sup>9</sup> Bulletin de la Soc. d'Anat., Paris, 1855.

<sup>10</sup> Bulletin de la Soc. d'Anat., Paris, 1875.

<sup>11</sup> Transactions of the Pathological Society of Philadelphia, 1875-76.

<sup>12</sup> Archiv f. Path. Anat., 1865, vol. xxxi.

<sup>13</sup> London Lancet, 1858, vol. i.

double with double deficiency of tibia),<sup>1</sup> and others. The ulna is much less frequently missing, the only cases that have been met with in my search being reported by Schnelle,<sup>2</sup> Senfleben,<sup>3</sup> and A. Sydney Roberts,<sup>4</sup>—one each. Defects of the bones of the forearm are usually associated with a deformed condition of the hand, diminution of the number of fingers and metacarpal bones being most common, and when the radius is the deficient bone the condition known as club-hand is apt to be present.

As to the bones of the lower extremity, a case of entire deficiency of both femora has been recorded by Williams,<sup>5</sup> and instances where it was in a rudimentary state are reported by Ehrlich<sup>6</sup> and Hirst.<sup>7</sup> Deficiency of the tibia has been observed, so far as I know, in thirteen recorded instances. J. K. Young<sup>8</sup> reports an interesting case, in which the defect was bilateral (complete upon one side and partial on the other), and mentions eleven other cases which he had gathered from the literature of the subject, the observers being Billroth, Albert (two cases), Myersohn, Pauli, Parker, Ehrlich (three cases), Thümmel, and Busachi. In three of these the defect was bilateral, completely so in two of the three. W. Henry White<sup>9</sup> reports the last case to which I find reference. It is an instance of complete bilateral absence of the bone associated with deficiency of the condyles of the femora, and with defects in both hands, the right one having only the thumb and the little finger (the other fingers and their metacarpal bones being missing), and the left having the thumb and the index and little finger (the ring finger and its metacarpal bone, and the middle finger, though not its metacarpal bone, being wanting). Thus, then, of the thirteen cases of tibial defect, in five the condition was bilateral—complete in three—and unilateral in eight.

In all these instances the fibulæ of the deformed limbs were shorter than normal, and the feet are without exception reported as being in a position of more or less extreme varus.

Deficiency of the fibula has been met with somewhat more frequently than the last-named deformity. Eighteen cases were collected by Myersohn,<sup>10</sup> and more recently two have been reported by Gould,<sup>11</sup> and one by Brothers and Pope,<sup>12</sup> associated in each instance with absence of two toes and diminution in the number of metatarsal bones, and being unilateral, the

---

<sup>1</sup> Transactions of the Pathological Society of London, 1882, vol. xxxiii.

<sup>2</sup> Inaugural Thesis, Göttingen, 1875.

<sup>3</sup> Virchow's Archiv, vol. xlv.

<sup>4</sup> Transactions of the Pathological Society of Philadelphia, 1885-87, vol. xiii.

<sup>5</sup> London Lancet, vol. xii.

<sup>6</sup> Virchow's Archiv, vol. c.

<sup>7</sup> Transactions of the Obstetrical Society of Philadelphia, 1887.

<sup>8</sup> American Journal of the Medical Sciences, 1888, vol. xcv.

<sup>9</sup> Transactions of the Clinical Society of London, 1888, vol. xxi.

<sup>10</sup> Virchow's Archiv, vol. lxxvi.

<sup>11</sup> Transactions of the Pathological Society of London, 1881, vol. xxxii., and Transactions of the Clinical Society of London, 1886-87, vol. xx.

<sup>12</sup> New York Medical Record, 1885, vol. xxviii.

foot in one of Gould's cases being turned outward, while in the other it was in the position of equino-varus.

As in the case of the upper extremity, deficiencies in the bones of the lower extremity are usually associated with a defective or deformed condition of the distal segment of the member, and thus with any of the foregoing there may be observed a diminution in the number, and a faulty position, of the bones of the tarsus and metatarsus, and absence of one or more toes.

Deficiencies of the fingers and deficiencies of the toes are so similar in many respects that they may be spoken of together.

There may be a diminution either in the number of the digits or in the size or the number of their segments; and sometimes, in addition to the absence of certain digits, those which are present will be observed to be smaller than normal, and to be lacking in the number of phalanges.

Fig. 2, from Annandale (*loc. cit.*), represents the hand of a girl, four and a half years old, which lacked the index, middle, and ring fingers, and the metacarpal bones of the two former.

The thumb was double, there being two first phalangeal bones. The two digits which were present were perfectly movable and useful for purposes of prehension.

FIG. 2.

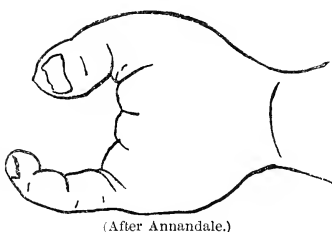

(After Annandale.)

FIG. 3.



(After Annandale.)

Fusion of two or more digits may occasion an apparent deficiency in development. Fig. 3, from Annandale, is from such a case, the patient being a child sixteen months old, the hand having apparently but three fingers, the ring finger being absent and the middle and little fingers webbed. Careful examination showed that the first phalanx of the ring finger lay obliquely in the web between the middle and little fingers, and that the other two phalanges were united to the corresponding ones of the little finger.

Cases may be met with, although rarely, in which the phalanges are deficient in number, one, two, or even all being absent from the digit. Dr. William Carson, of Cincinnati,

has kindly furnished me with the description of the following interesting case. The patient was a boy eight years of age, an only child, who presented a deformity consisting in the absence of the distal phalanx, and part of the second, from all the fingers of both hands, the thumbs being

normal. His mother exhibited the same deformity. Her father was the parent of twenty-four children, of which number, however, but five had survived to any age, and of these three had the same malformation as their sister and her son. The grandfather was one of eleven children, in five or six of whom the defect existed. He stated that it had been observed in the family for over one hundred years.

In contrast to this hereditary transmission of the same malformation is a case reported by W. S. Montgomery Smith,<sup>1</sup> in which hereditary defect of the digits was observed for two generations, while a representative of the third changed the routine by possessing a supernumerary thumb. The usual deformity of the family present in several instances for two generations had been a deficiency in the toes, the big toe being present, the second absent, the third rudimentary, and the fourth and fifth webbed. The paternal grandmother, from whom the malformation could be traced, exhibited, in addition to it, absence of both thumbs and a webbed state of the fingers.

The cause of congenital deficiencies is somewhat obscure. Doubtless in the great majority of instances they originate very early in fetal life. According to the theory of Hasse and Pauli,<sup>2</sup> they result from inflammatory adhesions between the amnion and the integument at a very early stage of development, the subsequent increase in the amniotic fluid causing the bands of adhesion to break up, the process bringing about distortions, amputations, etc.

Cases of intra-uterine amputation resulting from pressure of the umbilical cord would, of course, fall under the category of congenital deficiencies; but they are obviously of a different nature from instances where the member is present although imperfect in its development.

**Treatment.**—So great is the variety of malformations of this class that each case will, for the most part, have to be dealt with according to its own merits. To supply that which nature has failed to provide for an individual is plainly beyond the resources of surgery. On general principles, a malformed limb, unless the distortion is of an extreme degree, is of more use to its possessor than any artificial appliance could be, and therefore it is advised that the plan of treatment adopted be a conservative one. By the employment of properly-constructed apparatus a distorted hand or foot may be brought into a fairly good if not normal position, and compensation for the lack of a bone in the forearm or leg be made. To increase the muscular development of the part, massage and electricity, judiciously used, will be of service.

Operative measures may in certain cases be called for to correct the influence of a shortened muscle or a contracted fascia, or to remedy an otherwise irremediable deformity of a bone.

---

<sup>1</sup> Guy's Hospital Reports, 1888, vol. xlv.

<sup>2</sup> Archiv f. Klin. Chir., vol. xxiv.

Cases may be met with in which conservatism is out of the question, in consequence of the extreme degree of deformity of the limb, its articulations being so imperfect as to permit of little or no motion, and the member being rather an encumbrance to the individual than otherwise. Under such circumstances its removal would be advisable.

Hands deformed in consequence of the absence or defective development of fingers may sometimes be improved in appearance by surgical measures. Thus, rudimentary fingers, the phalanges of which are entirely absent or but ill developed, and which are of no service whatever, should be amputated, the scar resulting from such operation being far less unsightly than the deformity itself; and the webbed condition of some of the fingers, sometimes met with in association with defects of the hand, should be remedied by an appropriate operation. (See section on webbed fingers.)

Cases of deficiency in the toes will seldom require surgical treatment unless combined with some other deformity of the foot or leg. The unnatural appearance being concealed by the foot-wear, no interference will be called for on that score. A rudimentary or ill-developed and distorted toe, however, may be the source of annoyance, or may interfere with locomotion, and, under such circumstances, should be removed.

#### CONGENITAL CLUB-HAND.

This deformity is seldom seen by itself, being in most instances associated with osseous defects in the hand, wrist, or forearm.

In addition to these defects—notably imperfect development or absence of the radius, and deformities or deficiencies of the carpal, metacarpal, and phalangeal bones—its causes are similar to those which produce club-foot,—namely, pressure in utero, muscular contractions or anomalies, and paralysis.

**Varieties.**—Club-hand is either simple or compound. The simple varieties are named the radial, the ulnar, the palmar, and the dorsal, according to the direction of the deviation of the hand at the wrist. In the radial form the hand is in the position of abduction, in the ulnar it is adducted, in the palmar it is flexed, and in the dorsal it is extended. The most common is the palmar, in which the wrist and fingers are flexed, and the palm looks towards the flexor aspect of the forearm.

The simple forms are less frequent than the compound. Of the latter the radio-palmar is the most common. In this deformity the thumb and its metacarpal bone, some of the bones of the carpus, and part or the whole of the radius are usually absent. The hand is placed at an angle with the external border of the forearm, its radial aspect being sometimes in contact with the surface of the latter. At the inner side of the wrist the lower extremity of the ulna forms a marked projection.

The compound variety next in point of frequency is the cubito-palmar. In this form the wrist is flexed and the hand directed towards the ulnar or inner border of the forearm.



Dorsal club-hand, either simple or compound, is seldom seen.

**Treatment.**—Cases of an extreme degree of club-hand in conjunction with marked distortion of the extremity resulting from osseous and muscular deficiencies will seldom be improved by treatment other than the application of an apparatus with the object of partly compensating for these failures of development. Indeed, in some instances nothing whatever can be done to improve the condition, and the useless hand should be amputated. In cases of a simpler kind measures such as are employed for the correction of club-foot should be adopted: contracted tendons should be divided, an appropriate apparatus to overcome the deformity provided, and the tone of ill-developed or paralyzed muscles improved by the use of massage and electricity. After tenotomy has been performed, three or four days should be allowed to pass before the retention apparatus is applied and the process of bringing the hand towards its normal position by that means begun.

#### SUPERNUMERARY LIMBS.

Deformities of this kind are of extremely rare occurrence, the only cases that have been recorded, so far as I know, being the following: one of supernumerary arm, reported by Hartley,<sup>1</sup> the patient, a boy ten years of age, possessing an entire additional arm on the right side. A very singular case, reported by Grandin,<sup>2</sup> is that of a child having in the right arm two humeri, each articulating with a radius and an ulna, and between these were a third radius and ulna. There were three hands, that in what would be normally the radial side having four fingers and one thumb, the latter in a state of contraction, and on its ulnar side two rudimentary fingers. The middle hand possessed four fingers, all of them contracted, and the third hand had five fingers. Each hand was capable of independent motion.

Murray<sup>3</sup> has described the case of a woman with double hand, and Giraldes<sup>4</sup> that of a child with the same condition.

#### SUPERNUMERARY DIGITS—POLYDACTYLISM.

The largest group of cases of abnormalities of the extremities is that in which the deformity is due to an increase in the number of the digits or in the number of segments of which they are composed. While in the majority there is but one additional finger or toe, many cases are on record in which there have been more. Thus, Mason<sup>5</sup> reports an instance in which there were nine toes on the left foot. Annandale (*loc. cit.*) mentions a case in which there were seven toes on the left foot and six on the right, the individual having had also, at the time of birth, fourteen fingers; another

<sup>1</sup> New York Medical Journal, 1887, vol. xlvi.

<sup>2</sup> American Journal of Obstetrics, 1887, vol. xx.

<sup>3</sup> Proceedings of the Medico-Chirurgical Society of London, 1861-64, vol. iv.

<sup>4</sup> Leçons cliniques sur les Maladies chirurgicales des Enfants.

<sup>5</sup> St. Thomas's Hospital Reports, 1879, vol. ix.

case in which each hand had ten fingers, and each foot ten toes; and another in which there were six fingers and two thumbs on each hand.

Polydactylism is frequently hereditary, the deformity sometimes showing itself in several successive generations of a family.

Adopting the classification of Annandale, supernumerary digits will be found to comprise four varieties:

1. A rudimentary digit attached loosely or by a pedicle to any part of the hand or foot, or to another digit.

2. A more or less developed digit articulating with the head or side of a metacarpal, metatarsal, or phalangeal bone.

3. A perfect digit articulating with a metacarpal or metatarsal bone of its own.

4. A more or less developed digit united throughout its length with another digit, and articulating either with a metacarpal or metatarsal bone of its own, or with one common to it and another digit.

In regard to the first class, the digit is more or less rudimentary, having one or two ill-developed phalanges, and being attached by a slender pedicle. In the case of the hand such digits are seen most frequently on the ulnar border, sometimes growing from the hand itself, sometimes from the side of the little finger. They have been met with on the radial side, in the palm, and on the dorsal surface of the hand.

In the second kind the supernumerary digit may articulate either with an expanded or a broadened head of a metacarpal or metatarsal bone or phalanx, in conjunction with the normal digit, the two being enclosed in a common capsular ligament, or with an articular surface of its own, the head of the metacarpal, metatarsal, or phalangeal bone being in this case bifurcated so as to form two separate articular extremities, and the capsular ligament being sometimes, as in the former instance, common to both digits, and sometimes separate from that of the normal digit. When the additional digit articulates with the side of a metacarpal, metatarsal, or phalangeal bone, the articular facet for it will usually be found below the distal extremity of those bones. The articulation, as a rule, possesses a distinct and separate capsular ligament. Digits of this second variety are of little use, being generally limited in their mobility, and frequently ill developed.

In the third variety the supernumerary digit, having a metacarpal or metatarsal bone of its own, is well developed, movable, and useful, as a rule.

In the fourth class the union between the supernumerary digit and its neighbor is usually complete, and extends through their entire length.

FIG. 4.



Supernumerary finger, first variety.  
(After Annandale.)

Sometimes, however, this is not the case, the union being but partial, both in extent and in firmness. Instances of this variety are met with most frequently in the thumb and the great toe.

FIG. 5.



Supernumerary thumb, second variety. (After Annandale.)



FIG. 6.

Supernumerary toe, second variety. (After Annandale.)

It will be understood that these remarks apply to both the fingers and the toes.

**Treatment.**—Taking each variety separately, we shall be enabled to see more clearly the treatment appropriate to each. Digits of the first variety should be dealt with by removal, the operation being performed at as early an age as possible. The procedure is of the simplest kind, and consists merely in cutting through the pedicle with scissors or knife, taking care that none of it be left and that any arterial spurt-

ing which may occur be controlled by either a fine ligature or a suture.

Additional digits of the second class should also be removed; but the utmost care should be taken to preserve strict asepsis, for should there be but one capsular ligament and synovial membrane for the extra digit and the normal one, and should suppuration follow the operation, the result would be disastrous to the usefulness of the latter. When the head of the metacarpal or metatarsal bone is bifurcated, the part supporting the abnormal digit should be included in the removal. In the instances where the supernumerary digit articulates with the side of the metacarpal, metatarsal, or phalangeal bone, and the articulation is provided with its own capsule, the risk of injuring the articulation of the normal finger is not so great, but none the less the amputation should be carefully performed, with the observance of thorough asepsis. In some cases of the second variety the association of the articulation of the supernumerary digit with the normal one is so intimate that its complete removal without damage to the latter might be impossible. Under these circumstances it would be better to divide the proximal phalanx of the supernumerary digit just beyond its base, with either bone-forceps or a very fine saw, and so avoid disturbing the normal finger at all.

In the case of the toes, if in addition to a supernumerary digit of this variety there be much distortion of the normal one adjoining it, as is sometimes the case, both should be removed.

Superfluous digits of the third variety had better, as a rule, be left alone. Their removal, if attempted, would involve interference with the supernumerary metacarpal or metatarsal bones supporting them, and the resulting scar would be quite as unsightly as the normally-formed although superfluous digit, if not more so.

In cases of the fourth variety it will usually be found that the union between the supernumerary and the normal digit is so complete as to endanger the latter if removal be attempted. If the thumb be the subject of the deformity, even if the distortion be considerable, its usefulness may not be impaired to any great extent, and, although its appearance may be a source of annoyance, it does not justify our running the risk of impairing the utility of the member by an operation. In certain cases of incomplete union it may be possible to remove the supernumerary thumb with but limited injury to the normal one, care being taken, however, to preserve ample flaps from the soft parts to close in the gap left behind.

If the great toe be the seat of this deformity, and the degree of distortion be so great as to cause inconvenience or distress from pressure of the shoe, amputation of the entire toe is the only means of securing relief.

#### CONGENITAL UNION OF DIGITS—SYNDACTYLISM.

This deformity, like polydactylism, is one that is often met with. It consists in the union of two or more digits (1) by means of loose folds of skin,—the true “webbed” condition,—or (2) by a more complete connection of the soft parts of the fingers in addition to the skin, or (3) by fusion of the bones. The union may extend along only part of the length of the fingers, or it may be complete. Cases have been met with in which the condition was limited to the distal ends of the digits. An extreme degree of syndactylism is sometimes met with, in which all the digits of a hand or a foot are fused together and lose their identity in one ill-shaped mass or lump.

The first kind is that which is most common, and consists virtually in an exaggeration of the normal folds of skin between the fingers and toes. It is seldom that more than two digits of a hand or a foot are so united, but occasionally cases are seen where three, or even all, are “webbed.” While the condition does not necessarily interfere with the motions of flexion and extension, it may limit adduction and abduction, and certainly it diminishes the freedom of individual motion of the united digits.

In the second variety the digits are held together more or less firmly, the covering of skin and fascia being common to both or all so united, and their individual movement being an impossibility. Each digit may possess its own nail, or there may be but one nail for both (or for all, in case more than two fingers be the subjects of the deformity), a longitudinal groove (or grooves) indicating the portion belonging to each. The line of separation between these digits is generally indicated by a line or depression in the integument.

Fig. 7, from the hand of a patient of mine, a twin two months old, is an example of the second variety.

In the third class fusion of all the phalanges is rare, the union existing more commonly between only the proximal phalanges, or sometimes the medial phalanges as well. Each digit has, of course, its own metacarpal

or metatarsal bone. The individual movements are necessarily absent, and, although they may be separate, the distal phalanges are but slightly movable.

FIG. 7.

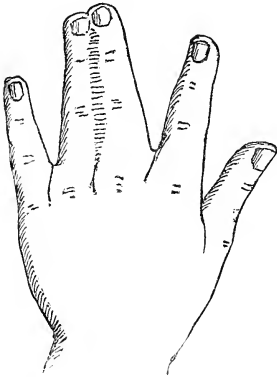

Webbed fingers, second variety.

exists, however, for the raw surfaces to unite and thereby cause the reproduction of the web. After its division, therefore, care should be taken to keep the fingers well separated by placing between them some folds of bichloride, iodoform, or borated gauze, and keeping them there, renewing them if necessary, until the fresh surfaces have skinned over.

When the web is more extensive, one of the following operations should be chosen.

*Norton's Operation.*<sup>1</sup>—The first step consists in raising small triangular or rounded flaps on the dorsal and palmar aspects of the hand, in the clefts between the fingers, the base of the flaps being on a line with the heads of the metacarpal bones. Next the web is divided, and lastly the flaps are united by fine sutures, any tissue which prevents their easy approximation having first been divided or removed.

*Didol's Operation.*—An incision is made along the median line of the palmar surface of one finger, and short incisions at right angles with it are made at its extremities. A longitudinal flap, which should be as thick as

**Treatment.**—For obvious reasons, in the majority of the cases of this deformity which come under the surgeon's observation, the fingers are affected. United toes, free from other abnormalities, give rise to little or no inconvenience, and therefore generally require no treatment. With the fingers, of course, the case is different, and it is a matter of great importance to the individual that the united digits should be liberated, as can always be done in at least the first and second varieties. There are several methods of effecting the separation.

In cases of true "webbed fingers" (first variety), if the web be not extensive, the simple division of the folds of skin is all that is necessary. A strong disposition

FIG. 8.

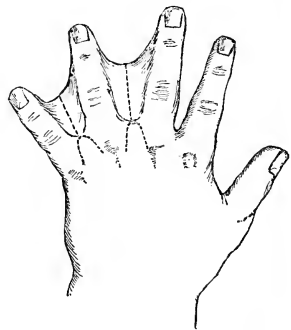

Norton's operation. (After Reeves.)

<sup>1</sup> For full description see British Medical Journal, 1881, vol. ii.

possible, is then dissected up. A flap of similar shape is then raised from the dorsal aspect of the other finger, the longitudinal incision being made along its median line. Each flap is then folded around the finger to which its base is attached, and secured by sutures.

FIG. 9.

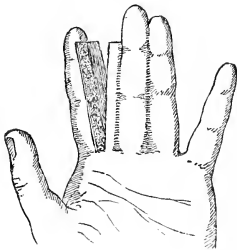

Didot's operation. (After Noble Smith.)

FIG. 10.

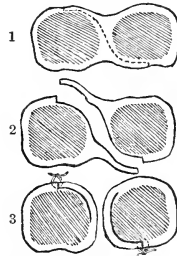

Didot's operation. Transverse section of fingers, showing the line of incision (1), the separation of the fingers (2), and the adjustment of the flaps (3). Diagrammatic. (After Noble Smith.)

In order to prevent the web, or the tissues which bind together the fingers, from reuniting, as they are especially prone to do in cases of the second variety, in which the association of the digits is quite close, it may be necessary to perform two operations. One consists in making a perforation in the base of the web and inserting a foreign body to be retained there until healing is complete, and the other in completing the cure by the division of the rest of the web. The foreign body used may be a small silver rod, having a broad, flat head at one end, and a screw upon which a nut is placed at the other. Or a rubber cord may be drawn through the perforation, and its ends, one passing up the palm, and the other up the back of the hand, secured to a wrist-band or bracelet. Of the two the last is to be preferred, for, being soft and pliable, it is not likely to give rise to much discomfort while it is worn, whereas the silver rod, being unyielding and projecting to a greater or less degree upon both the palmar and the dorsal aspect, might occasion some annoyance.

FIG. 12.

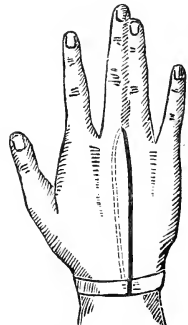

(After Noble Smith.)

FIG. 11.



(After Noble Smith)

CONGENITAL CONTRACTIONS OF THE DIGITS.

Although often seen in association with other malformations of the hand or foot, congenital contractions of the fingers and toes may occasionally be met with when no other abnormal condition of the extremity is present.

The deformity is caused by either fascial or tendinous contraction, either the flexor or the extensor tendons, or both, being at fault. It is usually not prominent at birth, but becomes more noticeable as the child grows, having a distinct tendency to increase slowly. Frequently it is an hereditary peculiarity, a particular finger or toe being affected in certain members of successive generations of a family.

In all the instances that I have met with of contracted fingers, the position of the digit was that of semi-flexion, full extension being impossible, the condition depending on shortening of the flexor tendons. In the toes, while contraction in the position of flexion is more common, I have seen a few individuals in whom, owing to contraction of extensor tendons, the toe was pointed more or less upward and could not be flexed so as to rest upon the same plane as the other toes. In all these cases the great toe was the one so affected. The second toe seems to be the one most liable to contraction in the position of flexion, the degree varying in different cases. Such a deformity may give rise to discomfort, either from an ingrowing condition of the nail, which in some cases, owing to the amount of flexion, is directed vertically downward, or else from the formation of a corn, as the result of pressure of the shoe, over the prominent first interphalangeal joint.

Sometimes one or more toes will be observed to be contracted in consequence of contraction of the plantar fascia.

**Treatment.**—Steps should be taken to correct the deformity, especially when it is slight, at as early an age of the patient as possible. In some such cases the employment of manipulation of the contracted digit may succeed in straightening it, but, if the condition exists in consequence of contracted tendons or fascia, other means must be resorted to. When the contraction is more marked, although moderate in degree, it may perhaps be corrected by the application of a splint of wood, rubber, or metal. If this fail, operative interference will be demanded, as it always is in cases where the deformity is very marked. Under these circumstances subcutaneous division of the contracted tendons or fascia must be performed, and the digit maintained in its proper position by the use of a splint. The operation will be more successful if not performed at too early an age, for it will be found a most difficult task to keep the retaining splint in position in very young children. Cases will sometimes be met with in young persons or in adults in which a contracted toe gives rise to much distress in consequence of its overlapping the adjacent toes. In these it will be proper to see first whether tenotomy, or division of the contracted fascia, if there be any, will correct the conditions. If these measures be found useless, amputation should be advised.

# CONGENITAL DISLOCATIONS.

BY SAMUEL KETCH, M.D.,

AND

LE ROY W. HUBBARD, M.D.

---

**Definition.**—The definition of a congenital dislocation is implied by the term which is used to designate this class of deformities, and signifies a loss of contiguity at birth between the bones forming an articulation.

**Synonymes.**—German, Angeborene Verrenkung; French, Luxation congénitale.

**History.**—While Hippocrates and others of the ancient writers undoubtedly observed these deformities, the first scientific knowledge of them was presented by Paletta and Dupuytren in the latter part of the last century and the first part of this.

It is possible, of course, for any articulation in the body to be the seat of a congenital dislocation, and a case has been reported where every joint presented this anomaly. We have personally seen one case, to be hereafter described, in which many congenital dislocations existed; but of all the articulations the hip-joint is the one most often affected. The knee-joint has been mentioned as coming next in frequency, and isolated examples of congenital dislocation at the shoulder, the inferior maxilla, and the smaller articulations have been reported.

Among fifty-seven cases of congenital dislocations collected from the case-books of the New York Orthopædic Dispensary and Hospital, there were fifty-five cases of dislocation at the hip, one case at the knee-joint, and one at the metatarso-phalangeal articulation. Most of our knowledge, therefore, regarding this class of cases must be derived from an investigation of the conditions which present at the hip-joint, as the trouble occurs so rarely at the other articulations that little or no opportunity is afforded for their study. Consequently we shall in this article deal principally with congenital dislocations of the hip-joint.

The statistics differ somewhat in regard to the relative frequency of the bilateral and the unilateral variety of this deformity. Thus, Pravaz<sup>1</sup> met

---

<sup>1</sup> Traité théorique et pratique des Luxations congénitales du Fémur.  
VOL. III.—60



with four bilateral and fifteen unilateral examples; Boyer with thirteen bilateral and twelve unilateral; of twenty-six cases which Dupuytren saw, only two or three were single, and of twenty cases reported by Holmes, sixteen were double. Stedman<sup>1</sup> analyzed twenty-five consecutive cases, and found fifteen unilateral and ten bilateral examples.

Of the fifty-five cases of congenital dislocation of the hip-joint, representing the total number applying for relief at the New York Orthopedic Dispensary during a period of ten years, from 1878 to 1888 inclusive, both joints were affected in twenty instances and one joint alone in thirty-five instances.

All of these cases have been personally examined by the authors, and they have been analyzed with special reference to etiology, sex, and location, with the following results. Of the total number, twelve occurred in males and forty-three in females. Of the thirty-five cases in which only one joint was affected, in eleven it was the right and in twenty-four the left. Three of the eleven cases with right-side deformity were males and eight females, and of the twenty-four cases whose left hip was affected four were males and twenty females. The twenty bilateral cases included five males and fifteen females. A comparison of the total number and each separate class will show that the proportion of females to males afflicted with this deformity was in the ratio of about three and one-half to one. Of Dupuytren's twenty-six cases twenty-two were females and four males, and of Holmes's twenty cases seven were males. There have been attempts to explain this preponderance of female cases, but none of them have been satisfactory, though the disproportion has been noticed by all observers. The left hip seems to be the favorite seat of the affection in the proportion of five to one. The proportion of bilateral to unilateral cases was greater than that observed by some writers and smaller than that observed by others,—viz.,  $36\frac{2}{3}$  per cent.

**Etiology.**—The etiology of all congenital deformities is obscure, and that of congenital dislocations is no exception to the rule. The theories advanced have been almost as numerous as the authors of articles on the subject, but none of them has trustworthy proofs behind it, and few are even plausible.

It may be interesting briefly to mention a few of the causes advanced.

1. Heredity (Dupuytren, and afterwards Stromeyer and Schreger).
2. External violence acting upon the fetus in utero (J. L. Petit).
3. Primitive alteration in the germ, or an aberration of the primitive force (Dupuytren).
4. Arrest of the development of the osseous portion forming the cotyloid cavity (Breschet).
5. Articular maladies occurring in the fetus during intra-uterine life (M. Parise and others).

---

<sup>1</sup> Buck's Hand-Book of the Medical Sciences.

6. Primitive alteration in the nervous centres (Chaussier, revived by Delpech and Guérin).

7. "Pathological spasmodic contractions of the muscular tissue, resulting from a perverted or disturbed condition of the excito-motor apparatus of the medulla spinalis" (Carnochan).

A careful examination of the histories of the cases reported above was made with reference to the cause of the deformity as stated by the mothers of the patients, and produced the following results. In forty-six cases no cause whatever could be assigned. Two were ascribed to a fall of the child in infancy, one to a fall of the mother before the birth of the child, one to a supposed accident to the mother, but of which she was very uncertain, one to an early attack of erysipelas, one to an abscess at the left external malleolus in a case of double dislocation, one to convulsions at fifteen months, one to measles, and one was a premature delivery.

Brodhurst<sup>1</sup> states that this deformity never occurs except in preterm-labor, and usually in breech presentations. But a careful inquiry in these cases showed that most of the labors were perfectly normal.

Dupuytren based his idea of heredity upon one remarkable case, but subsequent investigations have not strengthened the argument. In the cases analyzed by us no well-marked history of the deformity appearing often in the family was observed.

Moreover, all the causes assigned, with possibly one exception, could have no connection with the deformity in question, as they occurred either at a time when the joint was fully formed or after the birth of the child. The exception which might be noted is the case of the woman who fell early in pregnancy; but cases occurring during confinement from forcible delivery, etc., ought to be included, strictly speaking, under traumatic dislocations. Hueter has shown that where sufficient violence occurs to dislocate the femur a diastasis or separation of the epiphysis is more likely to result.

The theory of intra-uterine joint-inflammations seems to be scarcely tenable, as the results of such ante-partum diseases are never present when the joints are examined after birth.

If the deformity were due to marked changes in the spinal cord, either as the result of deficiency in nerve-tissue or in consequence of inflammatory action producing paralysis of certain groups of muscles, we should suppose that the effects of such paralysis would be apparent after birth. While it is true, as Guérin<sup>2</sup> states, that in some cases there is atrophy of the thigh-muscles, we have never observed anything like a true paralysis.

The theory of Carnochan<sup>3</sup> seems to be a very fanciful one and incapable of demonstration, for it is difficult to imagine spasmodic contraction of

<sup>1</sup> Lectures on Orthopædic Surgery.

<sup>2</sup> Recherches sur les Luxations congénitales.

<sup>3</sup> Etiology, Pathology, and Treatment of Congenital Dislocations of the Head of the Femur.

muscles sufficient to produce luxation of the femora which would disappear as soon as the child was born.

The idea that congenital dislocations are the result of developmental anomalies is the most rational of all, and receives support from the fact that children who are the subjects of the deformity are generally healthy at birth, showing entire absence of disease, past or present, of the joint-structures involved. Again, the occurrence of cases of multiple congenital dislocations would tend to support the theory of improper development or vice of conformation.

The following case will perhaps serve as an illustration. For the photographs (Figs. 1 and 2) and very careful notes upon the case we are indebted to Dr. T. Halsted Myers, of New York City.

Francis M., a patient in the service of Dr. Ketch at Randall's Island Hospital, was first seen in the spring of 1887. For some time the attendants and physicians at the hospital had noticed the peculiar walk of the child, but it had been ascribed to the condition of the feet, as they were in the position of a marked talipes equinus. It was impossible to obtain any early history of the patient. The following are Dr. Myers's notes on the case.

Francis M. Bilateral congenital dislocation of the femora; bilateral dislocation of the head of the radii; abnormal laxity of all the joint-ligaments; double congenital talipes equino-varus.

FIG. 1.



Shows the talipes, the hyperextension at the knee, the prominence of the trochanters, the consequent spinal lordosis, also the prominence over the head of the radius.

FIG. 2.



Shows the prominent trochanters, the lordosis, the dislocation of the radial head, and the hyperextension at the wrist and metacarpophalangeal joints.

In this case the typical pose and walk are exaggerated by the condition of talipes. To maintain a position of stable equilibrium there must be, and is here, a hyperextension at the knee to allow the heels to touch the ground, and this in turn requires a compensatory exaggeration of lordosis.

Examination of the individual joints shows that the inter-phalangeal joints of the toes

allow an extreme lateral and antero-posterior gliding motion without actual dislocation, flexion to ninety degrees and extension to one hundred and ten degrees.

The metatarsophalangeal joints present the same degree of laxity of their ligaments. Flexion is possible to eighty degrees, extension to one hundred and ten degrees.

The tarsal and ankle-joint motions are restricted, owing to the equino-varus deformity. The inner band of the plantar fascia is tense and prominent, and the tendons of the posterior tibial group of muscles prevent full flexion at the ankle.

At the knee-joint flexion is allowed till the leg touches the thigh; extension is possible to one hundred and thirty-five degrees. There is also a marked lateral mobility at this joint. Slight rotation also is allowed in the extended position, while in flexion of forty-five, ninety, or one hundred and thirty-five degrees as much as forty-five degrees of rotation is possible. The patella can be inclined on either its inner or its outer edge at an angle of fifty degrees.

At the hip-joint the characteristic deformity is present, the head of the femur being readily felt on the dorsum ilii. There is very little telescoping of the joint, but rotation is possible through ninety degrees inward as well as outward. The trochanter major lies half an inch above the level of the anterior superior iliac spine, even when the child is lying down. Extension, abduction, and adduction are normal. Flexion can be made to forty degrees.

The spine is flexible, but not markedly so.

In the upper extremity the inter-phalangeal joints allow the same free lateral and antero-posterior gliding motion as was observed between the toes. Flexion and extension to ninety degrees are possible. The metacarpophalangeal joints allow extension to one hundred degrees.

At the wrist there are flexion and extension to seventy degrees, and at the inferior radio-ulnar articulation motion is very free, allowing complete dislocation of the bones in an antero-posterior direction.

At the elbow-joint pronation and supination are not restricted; there is also free flexion except in extreme supination; extension is exaggerated twenty degrees. The head of the radius is completely dislocated upward and forward, lying directly in front of the external condyle of the humerus in the radial depression; and the dislocation cannot be reduced. The prominence at the outer aspect of the joint usually produced by the external condyle is here formed by the head of the radius. (See Fig. 2.)

At the shoulder-joint no abnormalities were discovered. The lax ligaments of the sterno-clavicular articulation allow almost a complete dislocation upward and backward.

Both sides of the body are similarly affected, but the left side to a more marked degree.

To summarize, then, we may say that the cause of congenital dislocations is probably some change in the central nervous system of the fetus, which produces a perverted development and growth of the osseous, the ligamentous, or the muscular tissues of the joint, or perhaps of all of them together.

**Pathology.**—The appearance of joints which have been the seat of congenital dislocation varies somewhat with the age of the patient, and there is consequently some difference in the descriptions made by the several observers. In the essential points, however, all agree.

The acetabulum is sometimes deficient, but more commonly exists as an oval or triangular shallow depression in the bone: in rare instances it may present as a bony protuberance. Sometimes there is an abortive attempt to form a new acetabulum on the dorsum ilii, without, however, any true bony deposit, and the depression so formed may be lined with a synovial membrane and have a fibrous capsule attached to its margin, or it may be smooth and hard. The old capsule usually remains attached to the margin of the rudimentary acetabulum if one exists, and may be simply stretched

and loosened, allowing the head of the femur to play up and down within itself, or may be perforated so as to allow the head of the bone to escape entirely. Sometimes it is found converted into a ligamentous cord, and in such cases there is no attempt to form a new acetabulum. Carnochan (*loc. cit.*) found, in the case of a subject seventy years of age, that a new capsule had been formed of fibrous tissue, which was attached to the annular rent in the old capsule. The head of the femur is sometimes merely changed in form, being smaller than normal and flattened, or it may be entirely absent. In Carnochan's case it was friable, and the articular cartilage was very thin and delicate. The muscles about the joint present some changes, part of them being contracted and perhaps showing evidence of fatty degeneration, while others are hypertrophied.

In congenital dislocation of the knee-joint the tibia is generally drawn backward, presenting in the popliteal space, but several cases of forward dislocation have been reported. When the dislocation is backward, the ligamentum patellæ is stretched and the hamstring tendons are contracted; when forward, the reverse is true. The crucial ligaments are relaxed in both cases. The patella is sometimes absent, but generally is present, though out of its usual position.

Luxations of the other joints have been so rare that their pathology has not been studied.

**Symptoms.**—The symptoms of a congenital dislocation at the hip vary materially, depending on whether the affection is unilateral or bilateral.

In either case the deformity is not discovered until the child begins to walk, and it is doubtful if a diagnosis could be made before that time, as, in all probability, the head of the femur does not leave the acetabulum until the weight of the body is brought upon it. In case the deformity is bilateral, the gait of the child is a peculiar rolling or wobbling one, which is characteristic, and is the result of an endeavor to balance the side of the pelvis upon the sliding head of the femur. The heels are not usually brought to the ground, the weight being borne upon the balls of the feet. This peculiar method of locomotion is most marked when the child walks slowly, since in rapid walking or in running the weight of the body is transferred so quickly from one side to the other that the femora slide up only a short distance upon the ilii.

If the patient is stripped, two things will be prominently noticed,—viz., the extreme breadth of the pelvis and a lordosis of the lumbar spine. There is also obliteration of the normal joint-outlines, the nates being flattened below, while at the level of the iliac crests the hips are flaring. The thighs are separated from each other above, giving the perineum a square appearance. The lordosis of the spine is produced by an effort to sustain an equilibrium, since the heads of the femora are placed posterior to the normal acetabula.

If the child is placed upon a flat surface on its back and the thigh is flexed to a right angle with the pelvis, which is at the same time held

firmly in position with one hand, and with the other grasping the thigh upward traction is made, generally the head of the bone can be felt to move up and down upon the ilium. The range of motion varies from half an inch to two inches, and frequently the head of the femur can be felt passing over a depression or slight projection, accompanied by a distinct click. If the case has existed long enough to have formed a new socket and new attachments, of course this sign will be wanting or greatly modified. An application of Nélaton's line test will show the great trochanter to be distinctly raised, often as much as two inches.

In unilateral dislocation the walk is characterized by a distinct limp, varying in degree according to the amount of shortening and the age of the patient. Inspection will show only one joint affected as described above. The lordosis of the spine is less marked, and there is generally some lateral deviation, with the convexity towards the affected side. Examination on the table shows an inequality in the length of the limbs, but by using traction and making counterpressure upon the perineum this inequality can frequently be greatly lessened, and sometimes obliterated. There is the same telescoping of the joint as in the bilateral variety, and the trochanter on the affected side lies above Nélaton's line. Motion of the joint in both cases is usually nearly or quite perfect in all directions, except a slight restriction to adduction and outward rotation.

FIG. 3.

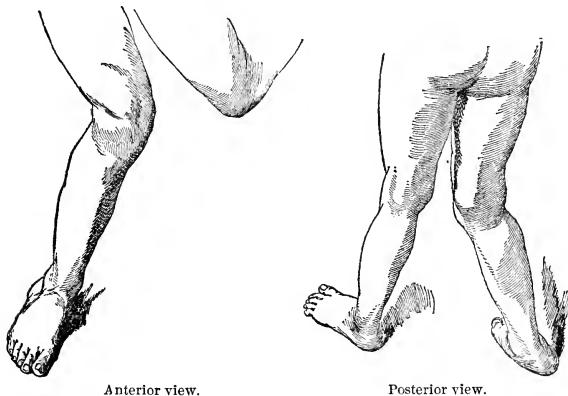

Anterior view.

Posterior view.

Congenital dislocation of the tibia forward and outward. (From a photograph of a patient at the New York Orthopædic Dispensary.)

Dislocation at the knee is generally discovered quite early, as the deformity is well marked and the joint is more exposed than the hip. In case of dislocation of the tibia forward, the limb is in a partly-flexed position and complete motion in either direction is impossible, while the condyles of the femur are prominent in the popliteal space. In the backward dislocation,

extension is impossible, the condyles can be felt anterior to the joint, and the head of the tibia in the popliteal space. The illustrations on the preceding page are from a photograph of a patient at the New York Orthopædic Dispensary. She was eighteen months old when she came, and the parents had noticed ever since she began to walk that the right knee "gave way" when she stepped upon it. There was no hereditary history of similar deformities. Examination showed relaxed ligaments at the joint, especially the internal, and a dislocation forward and outward of the tibia, with rotation outward, making the internal condyle of the femur prominent.

The condition resembles a marked genu valgum, as is easily seen by the illustrations.

**Diagnosis.**—It seems scarcely possible that a case of bilateral congenital dislocation could be mistaken for anything else; but Hilton<sup>1</sup> reports two cases seen by him in which apparatus for spinal disease had been worn, and we have recently seen a child at the New York Orthopædic Dispensary who wore for several weeks a plaster jacket which had been applied under the impression that the case was one of lumbar Pott's disease. The mistake doubtless arises from the lordosis of the spine which is present in these cases, as this is frequently a symptom of lumbar spondylitis. But an examination will show no deformity or rigidity of the spine nor any limitation of the thighs to extension, all of which are prominent symptoms in Pott's disease involving this region. The mistake is rather a serious one, for the application of any apparatus to overcome the lordosis of course destroys the compensating position, and the patient walks more unsteadily than before.

A mistake might be more easily made in the case of a unilateral deformity.

The unilateral congenital dislocation can be distinguished from the traumatic variety by remembering that the latter is very rare in children, that there is generally a history of injury, and that the child once walked all right, while in the congenital form the limp has been noticed from the time the child began to walk.

Separation of the epiphysis is sometimes met with in children; but here there is pain on motion, and usually distinct crepitus, which differs from the tendinous click sometimes found in moving a joint which is congenitally dislocated.

A congenital dislocation is distinguished from hip-disease by the absence of pain and reflex muscular spasm and by the freedom of motion in all directions.

Congenital shortening of the limb or the shortening which accompanies an infantile paralysis might be mistaken for a congenital dislocation, but a careful examination of the joint will at once establish the diagnosis, since in congenital shortening or that accompanying infantile paralysis the femur is held firmly in its normal position and the trochanter is not raised.

---

<sup>1</sup> Rest and Pain.

The distinction between a traumatic and a congenital dislocation at the knee is readily determined by the history.

The case illustrated resembles very much an exaggerated form of genu valgum; but manipulation of the joint disclosed the luxation of the bones and made the diagnosis easy. If every case is examined carefully and thoroughly, it is scarcely possible to make a mistake; but a careless, superficial examination may easily lead to error.

**Prognosis.**—The deformity under consideration, of course, has no influence upon the general health of the individual suffering from it, and there is no reason why such children should not live as long as those whose hips are normal. But the prognosis, regarding the cure of the deformity, is unfavorable, and the shortening usually increases. Cures have been reported, but treatment must be begun very early and kept up unceasingly for months, or even years, while the result is still uncertain. The plan demands not only employment of proper means on the part of the surgeon, but also such co-operation on the part of the patient and parents that it can seldom be carried out. Cases of self-cure do occur, as we have seen ourselves,—*i.e.*, the heads of the femora become fixed in a new position, and the gait is improved,—but the shortened extremities and the lordosed spine remain.

**Treatment.**—If the treatment of this affection is attempted, it must be begun, as stated above, very early, and must be unremitting and long continued. The general plan which has been adopted by all surgeons, outside of operative measures, consists in the gradual drawing down of the head of the bone by traction until it reaches the acetabulum on its proper site, and keeping it there until it will remain without the use of retentive force. When the dislocation is bilateral, the child must be kept upon its back fixed in one position while traction is made upon the thighs. Pravaz, of Lyons, has employed this procedure, and reports several perfect cures. The cure reported by Buckminster Brown<sup>1</sup> was certainly a very satisfactory one, and illustrates what can be done in these cases by perseverance on the part of both surgeon and parents.

If this plan of treatment is adopted, the child must be placed upon a smooth and moderately hard bed, and the trunk so secured that it cannot move up or down or from side to side without assistance. The thighs are flexed upon the trunk at an angle of about one hundred and fifty degrees, and traction is made in this direction. The force employed must be graduated according to the resistance, and may be increased as the patient becomes accustomed to it. After the head of the bone is brought down, it must be kept in this position for such a period that when the traction force is relaxed there will be no tendency to a return of the deformity. Then is the time to begin passive motion. This must be done in a most careful manner, for the application of undue violence might destroy in a moment the work of months.

---

<sup>1</sup> Boston Medical and Surgical Journal, June 4, 1885.



During the period of traction and following it, pressure should be made upon the trochanters by means of an elastic belt passing around the hips, and prevented from slipping up by means of padded straps passing under the perineum. After the bones show no tendency to displacement, an apparatus similar to that employed for double hip-joint disease may be applied, and the child may be allowed to move about in a wheel-crutch. After six months or a year the extension-apparatus may be removed, and the patient, still wearing the trochanteric support, may be permitted to use a wheel or other crutch, and gradually begin to bear some weight upon the limbs.

The unilateral variety has been treated, in some cases with marked success, by means of the Davis hip-splint or a modification of it in connection with pressure over the trochanter. Dr. John Ridlow has reported a case<sup>1</sup> treated in this manner in which he obtained a very excellent result, reducing a shortening of two and one-half inches to half an inch in about one year and a half. If this cannot be tried, the lameness may be greatly modified by means of the trochanteric belt and a high shoe. If there is atrophy of any of the muscles, of course massage, douches, and electricity are indicated.

Several attempts have been made within the last few years to cure this condition by an operation, but the results have not been sufficiently satisfactory to lead to a general adoption of any of the plans proposed.

In 1874, E. Rose performed resection of the articular extremity of the femur, and the same operation has been done by Margary.<sup>2</sup> The latter opens the joint freely by a straight incision from the trochanter to the posterior superior spine, the thigh being adducted and flexed to an angle of forty-five degrees. The head is severed by means of an Adams saw. A drainage-tube is inserted and the wound is dressed antiseptically. Extension of about seven pounds' pull is made immediately. He reports two cases, in which the results were excellent. The deformity was markedly less, the trochanters were not prominent, the lordosis of the spine had disappeared, and both patients walked with hardly a perceptible limp.

In 1882, Margary performed another operation, which on theoretical grounds seems preferable to exsection. He opened the joint by means of a T-shaped incision, and chiselled out the acetabulum sufficiently to receive something over half of the head of the femur. The dislocation was reduced, and the capsule strengthened by a strip of periosteum. Unfortunately, the boy died of pyæmia on the eleventh day, probably caused by septic catgut. We have not seen a report of any subsequent operation.

A congenital dislocation of the knee-joint is treated by reducing the deformity, which is generally easily accomplished, and then applying a splint which will retain the displaced bone in its new position. The results in these cases are quite satisfactory.

---

<sup>1</sup> Medical Record, Nov. 16, 1889.

<sup>2</sup> Archivio di Ortopedia, 1884, fasc. 5 and 6.

# CLUB-FOOT.

By E. H. BRADFORD, M.D.,

AND

E. G. BRACKETT, M.D.

---

**Synonymes.**—Reel-foot, Stump-foot, Talipes, Pes contortus, Kyllosis; French, Pied bot; German, Klumpfuss.

**Definition.**—Club-foot, or talipes, is an abnormal position of the foot in its relation to the leg. The name is popularly applied to that deformity in which the foot is twisted inward, so that the weight is borne on the outer side and front, instead of on the sole.

**Etiology.**—The deformity is usually congenital, but it may also be acquired after impairment of muscular strength, as occurs in infantile paralysis. As to its frequency authorities vary. Tamplin, out of ten thousand two hundred and seventeen cases of deformity, met with one thousand seven hundred and eighty club-feet. Of this number six thousand seven hundred and fifty-four were congenital. Duval found in one thousand cases five hundred and seventy-four congenital. Choussier, out of twenty-two thousand nine hundred and twenty-three newly-born infants, reports thirty-seven cases of club-foot, and Lannelongue, in fifteen thousand two hundred and twenty-nine births at the Maternity Hospital, found eight.

## CONGENITAL TALIPES.

**Causation.**—Heredity, on the part of both the father and the mother, has been established without doubt in a certain number of cases, but in a very large majority no trace of similar deformity in ancestors can be found. Devay and Boudin report that more cases are found in children from marriages of kin than among others,—one in one hundred and sixty-four births from marriages of kin, to one in nineteen hundred and three births from other marriages.

There are three chief theories which are advocated to explain the deformity in uterine life: (1) abnormal compression in the uterine cavity,—the mechanical theory; (2) retraction or paralysis of muscles, depending on lesion of the nervous system; (3) arrest of proper development of the foot.

The first of these theories is as old as Hippocrates. Ambrose Paré and

Cruveilhier maintained the same idea, with the addition of a suppressed blow received by the mother. Cruveilhier states that when club-foot is single it always affects the foot which lies anteriorly, and that when double this foot is affected to a greater degree. Malgaigne held the same opinion. The claim that this is caused by deficiency of liquor amnii is not substantiated by fact, and much is urged against the theory on this ground, as an absence of amniotic fluid is not found, as a rule, in cases of birth of infants with club-foot, the reverse being asserted by Duval, while scantiness of amniotic fluid has not been noticed as giving rise to the deformity. Furthermore, the deformity is noticed before the fourth or fifth month of intra-uterine life, at a time when the amniotic fluid is abundant and when no intra-uterine pressure is possible.

The theory of pressure is based on mechanical principles, and involves the disturbance of those changes in position of the fœtus which seem to be essential to its perfect development. Of this view there are many supporters, among whom are Berg, Volkmann, Cocher, Vogt, Banga, Parker, and others. It was brought into prominence in 1884 by Berg, who claimed that in an early stage of fetal development the feet are placed in a position of equino-varus, and that later, by a rotation inward or torsion of the lower extremities, the soles of the feet are brought in contact with the uterine wall and this abnormal position is corrected. The maintenance of this deformity after birth is due to a change in the structure of the foot from the normal, this difference being both in ligaments and in bones.

Against this theory of mechanical pressure it may be objected that prominently flexed knees, which should show distortion, are very rare. The normal rotation of the foot is due, not to the muscular power, as it occurs at a time when there are no muscles, but to the growth of the parts. At an early stage of uterine life these are rotated outward, so that when the surface of the thigh and the tibial border of the leg are pressed against the abdomen, the legs crossing each other at their middle and the limbs being bound at the knees, uterine pressure with the limb in this position necessarily confirms the position of equino-varus. But the lower extremities alter their position: the thighs are drawn inward and rotated so that the anterior surface instead of the inner surface lies next to the abdomen, and the soles instead of the outer surface of the foot are pressing against the uterine wall.

The second theory has the support of many writers. The theory has been held of alteration of the muscles with or without lesions of the central nervous system. Morgagni, Benjamin Bell, and Delpech believed that a contraction of certain muscles occasioned the deformity. Bécларd believed that the cause lay in the weakness of other muscles. In both of these theories the chief rule holds. In the nervous system they are results of central or peripheral disturbance, and in confirmation of this view may be cited the fact that the deformity is often seen in hydrocephalic and anencephalic fetuses, and in those suffering from spina bifida. On the

other hand, however, in a large majority of cases no alteration of the nervous system can be found. Out of six hundred and eighty-eight cases of congenital varus in the London hospitals, only two were affected with spina bifida. Duval, out of five hundred and seventy-four cases, found no case with other deformity. Lannelongue in seventy-eight cases of monstrosities found twenty-seven free from club-foot, and in thirty-two cases of spina bifida and encephalocele found only four with club-foot.

In favor of this, examples of analogy are quoted,—as, that deformity from nervous diseases often attains a higher degree on the right than on the left side, and that this is true with congenital club-foot, that from cerebro-spinal affections talipes varus is more common than talipes valgus, and that distortion is more common in the lower extremities.

The third theory, that of arrest of development of the foot, is the one maintained by Meckel, St.-Hilaire, Adams, Hueter, and others. According to these authors, as the feet are developed, at the sixth or seventh week, the foetus normally has the sole turned inward, and a permanence of this position would give a club-foot. Cruveilhier has denied this anatomical fact, but it is maintained by Martin and others.

Although this theory explains the deformity of varus, it is incapable of explaining the other forms of congenital talipes. But it has been modified so as to admit not only the arrest of development, properly so called, but also the malformation of the bone which forms the skeleton, an opinion defended by Bouvier, Brocher, Lannelongue, and others.

In short, it may be said that we are entirely ignorant of the causation of club-foot, and unable to give a satisfactory explanation of it.

*An acquired deformity*, which is not paralytic, may result from several causes, mostly mechanical, such as long-continued faulty position of the foot in bed, the weight of the bedclothes falling upon the toes causing the foot to drop down and turn in. This, however, is rarely of sufficient severity to simulate true club-foot. Inversion of the foot may also follow inflammation of the tarsus, but this is seldom severe. These acquired deformities are often the result either of chronic inflammation of the joint, as in rheumatism or gout, or of the weight of the body in standing, the latter causing flat-foot or valgus. Any interference with the muscular equilibrium may give rise to deformity and to faulty attitudes of the foot. When the foot is abandoned without support to its own weight, it is drawn in the direction of the strongest muscles, and an equinus results, as is often seen in fracture of a leg or after inflammation of the tibio-tarsals.

True club-foot is rarely produced by spasm of the muscles, although distortion is often brought about by certain nervous conditions attended with spasm. The deformity is usually nothing more than an exaggeration of a normal motion, most frequently being an equinus from contraction of the soleus and gastrocnemius, in spastic hemiplegia and paraplegia. The usual form occurs after paralysis, when certain muscles or groups of muscles are left either entirely paralyzed or weakened. A partial is always

more to be dreaded than a total paralysis. The foot in the act of walking, instead of striking the ground as it normally should, is not sustained in its proper position, and thus the weight of the body still further twists it and develops the tendency to deformity. Volkmann has shown that positions which are assumed as the result of gravity become permanent, and that the shortening is due, not to contraction of the muscles, but to the growth of the limb.

**Anatomy.**—In congenital talipes there are essential structural changes involving both ligaments and bones. In bone this change consists mainly in a deviation from the normal of the axes of the articular surfaces, this being associated of necessity with actual change in the shape of the bones. The changes in the ligaments are such as result from the former condition, they being shortened over the concave surfaces and lengthened over the convex, and therefore so arranged as to hold the bones firmly in the unnatural position which is assumed, thus preventing the return of the foot to a normal condition. The greatest variation in structure from the normal occurs in equino-varus. Each will require individual consideration.

**Varus.**—This variety is almost universally associated with equinus, making the equino-varus, so that in description this form alone will be regarded.

**Equino-Varus.**—The great majority of cases of club-feet are of this form. All degrees are seen, from a slight twist to a condition in which the soles are in apposition with the inner surface of the leg.

In this deformity the foot is flexed and inverted and the toes are turned inward. Pressure is borne either on the outer border of the foot, or, if the inversion be greater, on the dorsum. The position of the foot is such that the weight of the body tends to increase the deformity rather than to correct it, and in uncorrected cases bursæ and callosities form over the anterior part of the dorsum, which frequently become inflamed and limit the person's activity.

The distortion is of two kinds,—a movement of extension which takes place at the ankle-joint, and a movement of inversion which takes place at the transverse tarsal joint. The heel is so elevated that the sole and the toes are turned to the inside instead of downward, and the flexion of the inner border is such that the internal border presents a concavity and the external a convexity.

Extension of the foot is prevented by the tendo Achillis, and eversion by the tibialis posticus, deep flexors, fascia, and ligaments of the sole and the inner side of the foot. In this deformity the dissection will show anatomical changes varying according to the age of the distortion.

The os calcis by the elevation of the tuberosity is drawn from a hori-

FIG. 1.



Dorsal surface of club-foot.

zontal into a more or less vertical position. It is also rotated on its vertical axis, so that its anterior extremity is directed inward, and the posterior outward towards the fibula. Its posterior tuberosity is less developed than normal.

The cuboid bone maintains its connection with the os calcis, and follows the inward direction of the anterior extremity of the bone.

The astragalus does not partake of this rotation on the vertical axis, but follows the os calcis in its rotation forward on its horizontal axis, so that only the posterior portion of its superior articular surface is in contact with the articular surface of the tibia, and the anterior part of its anterior facet projects beneath the skin of the dorsum of the foot. Besides this displacement, the structural changes occurring in the astragalus are of great interest, being more pronounced, and playing so important a part in the maintenance of the deformity and forming an obstacle to its correction. This change consists in an alteration

of the angle which the neck makes with the body, this being so increased that the neck and articular facet point to a greater degree inward. The normal angle is thirty-eight degrees (average),

as given by Parker, and in the adult healthy foot the average is twenty-six and one-sixth degrees. In five cases of equino-varus the average was forty-nine and one-half degrees, varying between sixty-four and thirty-one. This deviation from the normal structure is shown in Fig. 2.

The formation which ordinarily exists in this deformity is considered by Parker and Shattuck as the normal one in monkeys; yet these animals are not talipedic, and this formation is not constant in them, if it exists at all. In two specimens examined the angle of inclination was not over twenty degrees. In two it was thirty degrees and thirty-five degrees, but in these the perpendicular of the plane of the articular surface was not a continuation of the line of the neck, but was nearly directly forward.

This condition also has the effect of approximating the scaphoid and the inner malleolus, so that in some cases on the inner side of the malleolus there is formed a facet. The cuneiform bones, with the scaphoid, are drawn inward and upward towards the internal malleolus. The three cuneiform and the three metatarsal bones, being closely connected with the scaphoid, are more twisted than the cuboid, though the metatarsals are not equally drawn in the rotation from without inward, but are spread out somewhat like the branches of a fan, in such a way that the anterior part of the foot is enlarged more than normal. In the medio-tarsal articulation a species of subluxation occurs by which the head of the astragalus is partly uncovered, the scaphoid being brought to the inner side towards the internal malleolus, sometimes touching it, so that in some instances a bursa is formed between them.

FIG. 2.

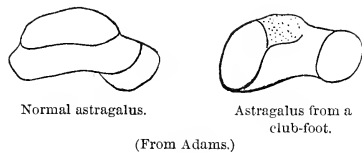

In addition to the changes in the foot there is frequently a slight alteration in the shape of the femur.

The alterations in the ligaments vary with the degree of deformity, but in all except the slighter cases form a serious obstacle to the cure. The internal lateral and posterior and plantar ligaments are chiefly involved. The anterior portion of the internal lateral, which passes from the malleolus to the scaphoid, frequently offers great resistance in the attempt to correct the position. Parker and Shattuck found on dissection that the deformity persisted after the muscles were dissected off, and not till certain of the ligaments had been divided was reduction possible. Parker considers the ligaments as holding the chief place in the maintenance of this deformity, and as being the only constant anatomical hinderance to rectification.

The different tendons assume an abnormal direction, and in general are carried farther to the inside, this being especially true of the tibialis anticus, the common extensor of the toes, and the long extensor of the great toe. The extreme extension of the phalanges on the metatarsal bones makes the extensor tendons of the toes very prominent, and this may cause painful pressure, which makes walking so painful as to necessitate their section.

As a rule, the muscles do not present at birth any alteration in structure. This is true of the nerves also.

*Valgus*.—Congenital valgus is much more rare than varus. It consists of a turning out of the foot, and usually the heel is drawn up. In standing the external border of the foot leaves the ground, and the whole weight of the body falls on the internal side of the os calcis, the inner malleolus, and the tubercle of the scaphoid. Walking is much more uncertain than in varus, and the nerves and vessels are liable to be compressed, causing painful locomotion.

The shape of the bones is but little altered, but their relative positions undergo more or less change. The axis of the os calcis is turned obliquely from behind forward and from within outward, and an articulation is formed between the os calcis and the external malleolus. The tuberosity is raised, and the bone tilted forward. The cuboid and scaphoid are rotated outward, and their outer border raised so that one part of the articular surface is left uncovered by the scaphoid.

*Equinus*.—Equinus is the rarest of congenital deformities and the most common among the acquired. All degrees occur. It may be so severe that the dorsum of the foot is simply a continuation of the line of the leg, or the heel may be only slightly lifted from the ground. In some cases the deformity is due less to the raising of the calcaneus than to a depression of the head of the astragalus. The axis of the astragalus may form an obtuse or even a right angle with that of the os calcis, so that the facet of the astragalus on the latter may be obliquely forward, and the astragalus depressed almost in a vertical line. A strong flexion of the medio-tarsal joint may take place, increasing the arch of the foot.

*Calcaneus*.—In this deformity the anterior part of the foot is raised, and

locomotion takes place on the heel. The degree of distortion varies from a right angle with the leg to a complete parallelism of the axis of the foot with that of the leg. There is usually a certain amount of abduction of the foot, which is due to a greater prominence of the action of the external extensors of the toes and the peroneus brevis. A calcaneo-valgus is thus produced, and in place of the normal arch this part of the foot presents a marked convexity. (Fig. 3.)

FIG. 3.



In many of the older cases there is no contraction which prevents the foot from being brought to a right angle with the leg, but the extensors are so weakened that there is little control over the anterior part of the foot. The articular displacement is exactly the reverse of what is found in equinus. The os calcis is deformed and enlarged, and in extreme cases its axis may be vertical, the weight of the body falling entirely on the end.

*Flat-Foot.*—In this condition the normal arch of the foot is obliterated, the inner border approaching the ground in proportion to the amount of deformity, so that in some cases the entire sole rests upon the ground. There are two forms, the congenital, which is analogous to valgus, and the acquired. The congenital form may be observed in certain infants, especially negroes, and is compatible with a useful member. In addition to this is the rachitic flat-foot, sometimes appearing before the child begins to stand.

Ordinarily there is no structural change in congenital flat-foot, but certain conditions have occasionally been observed, which, however, must be regarded as anomalous. Hall reports two cases of dorsal union: 1st, of the scaphoid with the os calcis; 2d, of the scaphoid with the cuneiform, resulting from an inflammatory process. In the former the foot was held in the position of a severe degree of flat-foot; in the latter, in that of a light grade of the deformity. Four specimens in the Vienna Anatomical Institute show congenital union of the os calcis with the scaphoid, with a marked valgus.<sup>1</sup>

*Acquired Flat-Foot.*—According to Duchenne, this form is always painful and causes notable interference with the usefulness of the limb. Hayward found sixty-five per cent. of cases of flat-foot between the ages of fifteen and twenty. As a predisposing influence of this deformity, the rapid growth, which may be accompanied by general muscular weakness, is important.

This condition is the result of the giving way of some portion of the structures which form the arch. The astragalus is usually considered the

<sup>1</sup> Archiv für Klin. Chir., 1880, Hft. 1, 4.



key-stone of this arch, but this is denied by Collin, and with good reason. The posterior pillar is formed by the os calcis, and the anterior by the scaphoid, cuneiform, and three inner metatarsal bones. The extremities of the two pillars are anchored by the ligaments, and strengthened by the tendons of the tibialis posticus and the peronei. This is the most important part of the arch, so far as its relation to this deformity is concerned. As long as the foot rests on the horizontal surface the os calcis is capable of supporting any reasonable amount of weight without the intervention of the ligaments, but if the heel is raised the body-weight is not transmitted directly through the os calcis, but the astragalus slides forward on the os calcis and throws the weight on the calcaneo-scapoid, interosseous, and plantar ligaments. In long standing the muscles become affected, and fail to afford the necessary support to this joint, so that the ligaments stretch in time, and an extension at this astragalo-scapoid joint takes place. In consequence of this altered relation of the pillars of the arch, the astragalus is rotated inward, so that it falls inside the plane of action of the tendo Achillis, which interferes with the action of the muscles whose function it is to raise the ankle and heel on the fulcrum of the ball of the foot. The muscles of the tibial and flexor side become relaxed, and the extensors and peronei become contracted. Whitman would, in general, formulate the cause as a disproportion between the weight which the foot is called upon to bear and the ability of the muscles to sustain it, and the simple breaking down from overwork.

Injury of the long peroneus may give rise to this deformity without other cause, which condition Duchenne believes to be due to a functional impotence of the long peroneus. If to the enfeeblement of the long peroneus, which has been termed the check-rein of the plantar arch, there is joined the perpendicular action of the tibialis anticus, and to this is added the action of the weight of the body, the calcaneo-cuboid ligament is weakened, so that the rising of the front of the foot is not checked. The weakening of this ligament is incident to flat-foot. In painful flat-foot there is an increasing disappearance of the plantar arch, so that in inveterate cases there may be a convexity of the under surface. Gosselin claims that painful flat-foot is due to a painful medio-tarsal arthritis. That this exists has been demonstrated, but it is uncertain whether it is a primary or a secondary condition.

*Pes Cavus.*—This term has been given to that deformity in which the ball of the foot is approximated to the heel, converting the normal arch into a vertical sulcus and rendering the dorsum very prominent. There is usually but little power over the anterior part of the foot, and locomotion occurs mainly on the heel.

Three varieties are recognized. One is due to the peroneus longus. The characteristic signs of this deformity are effacement under the projection of the metatarsals, an increase of the plantar arch, a diminution of the transverse diameter at the level of the heads of the metatarsals, and a twist

of the front of the foot on the dorsum, producing oblique folds on the plantar surface, a valgus movement in the calcaneo-astragaloid articulation, and projection of the tendon of the long peroneus below the external malleolus.

The second variety of cavus is due to paralysis of the gastrocnemius and soleus, in which the astragalus drops. In this the sole of the foot is lowered through the contraction of the long flexors, and a cavus is developed, either with or without the varus or valgus distortion.

The third variety of pes cavus has by Duchenne been designated *griffepied creux*. It may be acquired, but is often congenital. In either case it is due to a paralysis of the interossei and lumbricoid muscles and of the muscles which are inserted into the sesamoid bones of the great toe. By the paralysis of these, the tonic force of the muscles which extend the first phalanges and of those which close the last is not checked, and a forced extension of the first phalanges takes place, with an exaggerated flexion of the last. This depresses the heads of the metatarsals with so much force that the first phalanges are almost subluxated on the heads of these metatarsals. The plantar fascia contracts.

Duchenne claims that it is possible to confound this form of pes cavus with valgus or flat-foot, if the foot is examined while the patient is standing or walking instead of when it is in muscular repose. In the latter condition, the foot which is in the attitude of valgus touches the ground on the internal as well as on the external border, simulating flat-foot, but it may be distinguished from true flat-foot by lifting the foot. This form of pes cavus rarely produces pain in walking, and differs entirely from flat-foot due to paresis of the long peroneus.

*Non-deforming Club-Foot.*—Shaffer has described a deformity before not regarded as a distinct variety. In this the flexors of the ankle-joint proper are not able to perform the act of flexion, owing to the resistance of the plantar fascia or of the gastrocnemius or of both. There is generally a slight exaggeration of the tarsal arch, with little or no adduction of the tarsus or metatarsus; that is, the deformity is antero-posterior, not lateral. The ball of the foot is thus slightly approximated to the heel, the shortening being on the inner side, increasing the arch just posterior to the junction of the first metatarsal bone with its phalanx. Extension beyond a right angle is usually impossible, and with the effort to accomplish this the patient puts the toes in extreme extension.

Shaffer classifies these cases as follows: (1) those following acute poliomyelitis anterior; (2) those following simple uncomplicated malposition, habit, etc.; (3) those produced by traumatism, sprains, etc.; (4) those found after infectious diseases of children, especially diphtheria and scarlet fever; (5) those due to some remote trophic disturbance, sometimes seen associated with lateral curvature.

#### DIAGNOSIS.

There is no difficulty in recognizing the deformity of club-foot. In infancy a true club-foot is sometimes thought to exist when the trouble is

simply a temporary spasm of the tibialis muscle which turns the foot inward; this, however, passes away in a short time.

#### PROGNOSIS.

Nothing need be said as to the prognosis of the deformity. It does not correct itself, and if left remains persistent as a type of obstinate disfigurement. Although club-foot is not an affection which interferes with activity or usefulness, the deformity is so marked that it is a source of great mental suffering. Dieffenbach states that of all the women treated by him only one was married, indicating that this malposition is a great impediment to marriage. Lord Byron was afflicted with this deformity, and it is said to have been the cause of Talleyrand's entering the church.

The reputed growth of a child's foot is indicated by the measurements of Quetelet and Lange, who found the feet at three months of age to be from seventy-five to eighty-five millimetres long, at six months one hundred and one millimetres, at fifteen months one hundred and twelve, at eighteen months one hundred and sixteen, at twenty-one months one hundred and nineteen, and at twenty-four months one hundred and twenty-two millimetres long: that is to say, the foot increases with less rapidity the older the child grows, and if the foot is left to itself the deformity increases greatly in the first months of life.

#### TREATMENT.

The treatment of club-foot varies according to the patient's age and the duration and nature of the deformity, whether congenital or acquired. The object of the treatment is the correction of the malposition and the retention of the foot in the corrected position until any return of the deformity is impossible. The treatment may be purely mechanical, or may be both operative and mechanical. Mechanical treatment requires patient attention on the part of the nurse, and in certain cases is not possible.

CONGENITAL CASES.—TREATMENT IN INFANTS.—The treatment of club-foot in infants should begin as soon as practicable, and should be instituted as soon as the child is taking its nourishment well and is free from digestive disturbance. The position of the foot should be entirely corrected before the child begins to walk, and the sooner the correction is completed the better, for as long as the malposition persists there is danger of obstinate osseous deformity. If correction by mechanical means is possible, it is preferable to operation in infants, for the reason that it is usually more acceptable to the parents. It may be done by the hand or by mechanical appliances.

The hand was recommended by Hippocrates, who advised twisting the foot outward. Later writers have advocated the same method; but the results are not encouraging, although by persistent effort on the part of the parents in cases of slight degree it may be sufficient to overcome the deformity so that at the proper age a walking apparatus may be worn. For

other means, bandages, repeatedly applied, may be used, or some of the many appliances which have been devised. Many kinds of bandages have been used, but there is one object to be attained with all,—that the bandage shall harden quickly and shall be firm enough to hold the foot in the corrected position. Glue, starch, dextrin, and plaster of Paris have been tried, but the last-named has the advantage in rapidity and in strength.

**EQUINO-VARUS.**—The correction of this deformity should be divided into three steps, and should be, as far as practicable, brought about in the order mentioned: 1st, bringing the foot to the outer side; 2d, raising the outer edge of the foot; 3d, bringing up the front of the foot.

It should be borne in mind that it is desirable to bring the foot from its distortion to a position in which it shall point to the outer side of the leg. The outer edge of the foot should be brought to the same plane as the inner, or even to a higher one. The ball of the foot should be so raised that the heel may strike the ground first.

If it is attempted to correct the distortion by daily manipulation, the foot should be grasped with the sole in the palm of the hand, the fore-part of the inner border pressing against the ball of the thumb, the fingers over the dorsum, and the foot gently everted, abducted, and flexed. To do this the right hand must be used for the left foot, and *vice versa*. No limit can be made to the extent to which this should be employed, but only persistent effort will be successful, and it is unwise to attempt this method unless the physician is sure of intelligent aid from the mother or nurse, and then only in cases of slight degrees of deformity. Mechanical appliances will be necessary later, as after correction by other means.

**BANDAGES.**—Correction by bandages is the same in principle whether plaster or other material is used. The foot must be well protected by cotton, care being taken to insert small pieces between the toes, and the bandage should extend from the toes to a little above the knee. Considerable correction may be obtained while putting on the bandage by so adjusting the turns as to pull the foot into the desired position, but reliance must be placed mainly upon the forcible holding of the foot in as nearly as possible a corrected position while the plaster is hardening. The bandages should be renewed every two or three weeks until the foot is so far corrected that a retentive appliance can be worn.

Beely, of Berlin, has devised an apparatus which is useful in correcting the deformity in infants, and may be used in place of the bandages. It is shown, slightly modified, in Fig. 4. It consists of a steel strip, *A*, jointed at the knee and hip, with a band which encircles the pelvis, *B*, and is secured to the outer side of the leg by straps above and below the knee. At the ankle this is made to pass in front of the leg *C* to the other side, and is then continued downward and bent so as to pass beneath the

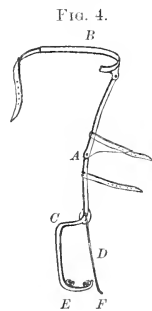

foot. This portion is provided with two buckles, *E* and *F*, which are attached to adhesive plaster applied to the leg in much the same manner as for extension in hip-disease, and serves to keep the foot from slipping up away

FIG. 5.

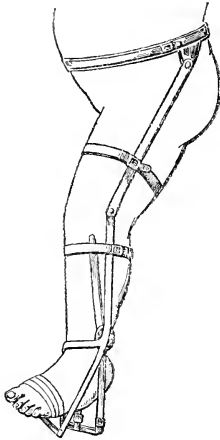
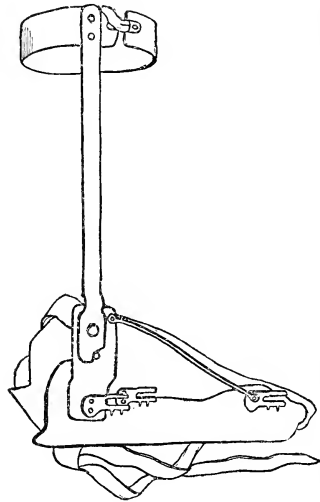

FIG. 6.



from the appliance. At the point where the upright turns to cross the ankle is fastened a rod of soft tempered steel, *D*, which projects downward and forward and is bent to suit the direction in which the pull is to be made. Adhesive plaster is then wound round the foot at the level of the ball of the toes, in the direction of over the dorsum to the inside and under the sole, and the end is fastened to the extremity of the spur. By this means the deformity should be corrected in a few weeks, after which a retentive shoe will be necessary. The apparatus applied is shown in Fig. 5.

For correction by mechanical means Taylor's club-foot shoe has the advantage of being simple and easily applied. It is useful for slight degrees of deformity or after the foot has been nearly corrected by other means, but its greatest value is in its use as a retention apparatus. It is shown in Fig. 6, and consists of a piece of steel fitted to the shape of the sole, with an upright on the inner side, and provided with an ankle-joint so arranged by a stop as to arrest flexion at a right angle. In applying the apparatus the sole is pressed firmly into the shoe, and the foot held in its place by the straps and buckles. To do this it is necessary that the upright should be bent forward, and it will then lie obliquely across the leg. This should then be carried into its position on the inside of the leg and secured by the strap at the upper extremity, which is for that purpose. By this motion the foot is brought forcibly into position. It is important that the

heel should be retained well down on the sole-plate, but occasionally it is difficult to accomplish this. It may, however, be done by applying adhesive plaster to the leg and securing it to buckles at the heel of the shoe before carrying the upright into position. The foot in position is shown in Fig. 7.



It often happens that there is an obstinate tendency in the toes to turn in or out: this is beyond the control of the patient, and it becomes necessary to overcome it by means of apparatus. This protection is more obviously necessary after operation, and may be easily accomplished by extending the upright to the pelvis, to which it may be secured. The arrangement is shown in Figs. 8 and 9.

This case was one of extreme deformity, as shown in Figs. 10, 11, and 12. One foot was corrected by the employment of extreme force, the other by the same method with the addition of astragaloid osteotomy. The result after four weeks is shown in Fig. 13.

FIG. 8.

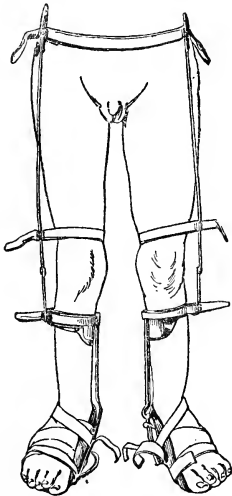
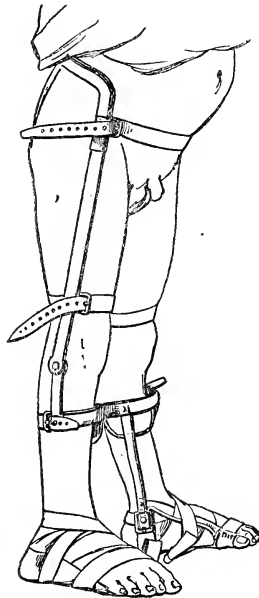

FIG. 9.



In many cases mechanical treatment alone fails to effect a cure, and division of the unyielding structures becomes necessary. Tenotomy is required because the muscles are powerful structures, but their division is not an essential part of the treatment. It is a mistake to divide the

FIG. 10.



FIG. 11.



FIG. 12.

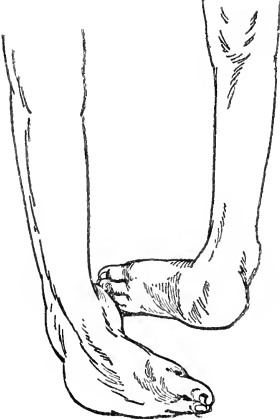

FIG. 13.



tendons according to any fixed plan or rule, the only wise course being to wait till the progress of the foot towards rectification indicates that some structure must be cut. Division of anything except the tendo Achillis is rarely necessary, and this should not be done until after the foot has become unfolded, so that the deformity has become an equinus.

Some writers, however, advocate division of the shortened tendons and ligaments before the mechanical treatment. The age at which patients should be operated on is a matter of discussion. Some assert that it should not be done before the end of the first year, others that it is advisable to interfere as soon as possible. Stromeyer operated on an infant twenty-four hours old. In some cases division of the calcaneo-scapoid ligament is necessary. After tenotomy the foot should be forcibly straightened, so that any remaining fascia or shortened tissue shall be torn or stretched, and it is absolutely necessary that the foot be over-corrected. It can be placed in this position in a fixed bandage, and allowed to remain until the incisions have healed. This practice is not recommended by some surgeons, on account of the fear of non-union of tendons; but clinical experience warrants the statement that such fear is groundless, and much time and discomfort of the patient are saved by this procedure. The details of the operation are described farther on. For fixation the writer prefers the application of silicate-of-potash bandages directly to the foot, which is first protected by a layer of sheet wadding, or by a bandage neatly applied so as to avoid wrinkles. Over the silicate, which requires two or three days to harden, a plaster-of-Paris bandage is wound. If this is properly made, it becomes stiff in a few minutes. In three or four days this can be cut away, leaving the hardened silicate bandage, which is light and not clumsy.

Both the silicate and the plaster-of-Paris bandage should be applied above the knee, with the knee slightly flexed, otherwise an inversion of the foot will take place. While the plaster is hardening it is essential that the foot should be held well corrected, otherwise the desired amount of over-correction will not be obtained, and a second operation or subsequent mechanical treatment will be required.

There are two objections to the use of fixed bandages,—the danger of sloughing of the skin, and the impossibility of further correcting the foot from the position in which it has been placed. The first objection may be avoided by skill in applying the fixed bandages; the second must be made as slight as possible by care to correct fully while the plaster is hardening. Mechanical means to complete the correction are rarely necessary if the operation is properly done, but the use of a retentive appliance is required till the child walks with the foot in a perfectly normal position, which may be a long time.

**TREATMENT OF OLDER CASES.**—Of the treatment of this deformity in older children, who are able to walk, very much the same may be said as of that in infants, except that mechanical correction is much more tedious, and therefore operative means are to be preferred.



In children of five years and upward there is required, as a rule, the use not only of the tenotome, but also of considerable correcting force. Mechanical means alone require much patience on the part of the surgeon and much time on the part of the patient, which can be avoided by the use of the tenotome and a forcible correction, while with older, relapsed, and resistant cases still more difficulty is encountered.

Of the treatment of club-foot by the employment of apparatus, Panas speaks as follows: "The results obtained by the employment of appliances alone not only leave a great deal to be desired, but in a small number of fortunate cases when the cure has taken place it is only attained at the price of a great deal of suffering and a very long time, several months or one or two years, and sometimes more."

This difficulty lies partly in the firm condition of the tendons, fascia, and ligaments, and partly in the amount of distortion of the tarsal bones. Simple tenotomy will not ordinarily suffice to overcome the distortion, but combined with the use of force may, if persisted in, result in a cure, although in some cases, even with the successful employment of mechanical force, a great deal of time is required.

**OPERATION.**—For operative measures the following are open for choice: tenotomy, open incision, use of extreme force, tarsal osteotomy, tarsal resection.

No definite rule can be laid down for the application of the above procedures, but in general it may be said that the simplest methods should be first considered, and the others used only as in each case the indications for extreme measures present themselves.

**Tenotomy.**—Tenotomy is one of the simplest and least weighty factors in the treatment of club-foot, but it should be regarded as merely an adjunct to other means. Applied for the first time in the treatment of congenital torticollis, it was practised later by Lorenz, Sartorius, and Michaelis for club-foot. Delpret, guided by accidental section and rupture of the tendon, was the first to divine the indications for a scientific tenotomy, and Stromeyer, Bouvier, and Guérin have made the operation indispensable.

In the section of muscles of the foot, one proceeds differently according to the case, sometimes making the incision from the skin towards the tendon, and sometimes passing the tenotome underneath the tendon and cutting towards the skin. Bouvier calls the two methods of procedure sub-tendinous and supra-tendinous section. According to many surgeons, the choice is a matter of indifference, but the sub-tendinous method is sometimes to be preferred as the simplest in its execution, and as permitting complete section of the tendon without risking the skin. The supra-tendinous method is to be preferred where the tendons are not very salient, as in young children, or where they lie close to bone or in the neighborhood of vessels and important nerves.

The reparation of divided tendons has been made a subject of numerous investigations since Hunter's original experiments in 1767. After division

the cut ends are separated to a variable extent, depending on the length of the muscle to which the tendon belongs, on the position in which the limb is placed, and on the surrounding attachments of the tendon. There extends between the cut ends a tubular sheath of active tissue, which chiefly furnishes the reparative material. This sheath becomes vascular, and after the absorption of any blood that may have been effused within it the interval between the divided ends of the tendon becomes filled with lymph, which gradually becomes fibrillated and forms a firm bond of union between them. The new material so closely resembles the old tendon, and is so intimately blended with it, that for a time it would be difficult to distinguish them, except for a certain translucency which is possessed by the former and is not natural to the latter. The tendon is thus increased in length to the extent of the interval by which its ends are separated. The separation should not be maintained at its full extent at once, lest the uniting medium be thin and weak, but should be gradually produced by altering the position of the limb.

The time occupied in obtaining the required elongation varies from two to six weeks, according to the activity of the repair and the severity of the case, and with proper operative procedure with a healthy subject a perfect use of muscle of normal length is obtained. Doubtless adhesions often form between the divided tendons and the surrounding structures, but in ordinary cases they are not of the least consequence, for they give way to the manipulation or use of the foot, and do not interfere with the function of the muscle.

*Section of the Tendo Achillis.*—The patient should lie on his face, an assistant holding the foot. Having made a longitudinal fold of the skin, the surgeon enters the knife parallel to the border, passing it flatwise between the tendon and the skin. The blade of the knife is then turned towards the posterior surface, and by pressure of the left index finger on the skin over the back of the tenotome the sensation of the cutting of the tendon can be felt. The assistant should raise the end of the foot, so as to make the tendon somewhat tense during the section. The only protection necessary is to be assured of complete division.

*Section of the Tibialis Posticus.*—If the muscle is to be divided in the leg, the foot is placed on its external border. The surgeon divides the skin by means of a pointed tenotome two centimetres above the tip of the internal malleolus, and on a vertical line situated half-way between the posterior border of the malleolus and the corresponding border of the tendo Achillis, and passes the tenotome perpendicularly downward to the depth of ten or fifteen millimetres. The handle of the instrument should then be turned so as to describe the arc of a circle, and the tendon divided vertically inward. The tenotome is then withdrawn and a blunt-pointed one inserted. This should be so directed as to pass behind and under the tendon, and it is then sufficient to turn the cutting edge forward and to move the instrument gently forward and back, the assistant at the same time turning

the foot in the direction of abduction. It is essential, in order to avoid wounding important parts, to adhere strictly to the rules laid down. If the incision is made too near the malleolus, the internal saphenous vein may be opened, and the nerve of the same name may be cut. If the incision is made too near the tendo Achillis, there is danger of dividing the tendon of the long flexors of the toes and the posterior artery and nerve. Bonnet thinks that he has wounded this artery more than once, but without serious injury. To avoid this possibility, Velpeau advised cutting this tendon in the foot, in a line from the top of the internal malleolus to the scaphoid; but this is not easily done in infants.

*Section of the Tibialis Anticus.*—The division of this tendon is more easy, and it is sufficient to be guided by the prominence of the tendon put on the stretch by abducting the foot. To avoid wounding the deep parts it is better to enter the tenotome under the tendon.

*Division of the Plantar Fascia.*—It is advised by some writers to divide the plantar fascia before the tendo Achillis, as the latter acts as a support for stretching the foot when the fascia is divided. No fixed rules are necessary for this operation, but the tense fascia should be felt, the tenotome inserted subcutaneously, the blade turned inward, and the division made with care. Walsham<sup>1</sup> reports the appearance of an aneurism as large as a marble two weeks after this operation in a boy of seven. It was cured by pressure maintained for two months over the posterior tibial artery.

Many times the tenotomy combined with forcible correction is not sufficient to complete the restoration of the foot to the normal position. The obstacle is often the resisting fascia, which cannot be thoroughly divided subcutaneously. In such cases section by open incision may be performed.

**Open Incision.**—The advantage of this operation in club-foot is the facility of complete division of all the soft tissues. The method is as follows. An incision is made along the inner side of the foot from the top of the malleolus well down to the inner edge of the first metatarsal bone. After the skin the other tissues are divided with care, using a director if necessary. The tibialis tendon is cut across at its insertion, and the plantar fascia is divided by a tenotome or a long thin knife. The artery can be spared by careful dissection, but may be sacrificed if necessary. A cross incision towards the sole of the foot from the middle of the long incision is sometimes essential, but it is desirable, if possible, to avoid this. The foot is then brought into as normal a position as possible, thorough aseptic dressings are applied, and the foot is fixed in a plaster-of-Paris bandage.

**Use of Extreme Force.**—By this is meant the application of such force, in the direction of correcting the deformity, that the ligaments are torn or stretched; and this should be done under an anæsthetic. The chief difficulty is that of applying the force directly, as, owing to the shape and

---

<sup>1</sup> Lancet, January 28, 1888.

size of the foot, it is almost impossible by the use of the hands alone to twist the foot in such a way as to stretch or tear the resisting ligaments. An apparatus has been devised for this purpose by Dr. T. G. Morton, of Philadelphia, a modification of which is indicated in the accompanying diagram (Fig. 14). The object of the appliance is to exert pressure, under control of the operator, in three directions, and also to enable him to twist and raise the front of the foot. It is inapplicable to small children.

The apparatus consists—

1. Of a plate large enough for any foot.

2. Of three steel buffers or padded plates which are attached at the ends to steel screw rods playing through sockets with a

female screw thread at the sides of the large plate. By turning the screws, which is done by the handles, the plates or buffers are pushed forward. They should be placed so as to press (1) upon the side of the first metatarsal, (2) on the side of the os calcis just beneath the inner malleolus, and (3) on the outer side of the foot over the projecting head of the astragalus. The female screw through which the male screw plays is adjustable upon an arm curved so that pressure can be applied when it may be found necessary.

The sockets and arms are arranged so that they can be shifted and placed at any point along the side of the large plate, or can be shifted from side to side, so that the appliance can be used for either foot.

3. A straight rod, extended in the plane of the plate, gives increased power in raising the front of the foot. This is not always needed, and can be removed.

The procedure in this method is as follows. Tenotomy is performed in the usual way, the plantar fascia being divided first, then the tendon of the tibialis posticus if necessary, and, after the deformity at the arch of the foot has been in a degree corrected, the tendo Achillis. The foot is then forcibly manipulated with the hands, pressure being exerted in a direction to overcome the deformity. If this is not sufficient for correction, the instrument is to be applied so that the screws will press on the foot as described. The correction will be done gradually, although at times the fibrous tissues will be felt to tear. An assistant steadies the leg, and the operator first attempts to change the varus into a valgus, without reference to the equinus. By turning the plate outward or upward the twist of the

FIG. 14.

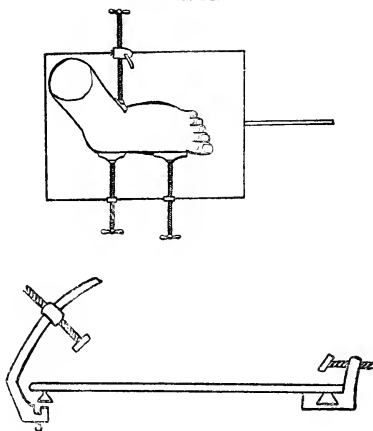

foot and the equinus can be corrected. The skin on the inner side of the foot frequently becomes tense, but the danger of its rupture is not a practical one. In many cases the correction may be accomplished at once, but if much resistance is encountered it is best to use some time, and allow the stretching to be gradual. The foot should then be put into a plaster bandage, and firmly held until the bandage is fixed.

The objections to this forcible correction after tenotomy are chiefly theoretical, no ill results having been known to follow. The injury done to the foot is not greater than that of a severe strain, and the patient is given the advantage of a painless correction and rapid cure. An objection which is sometimes raised against this method is the sup-

FIG. 15.



Girl of eighteen treated by the method of extreme force.

FIG. 16.



Result in the same case.

posed risk, but this is not so great as would be thought. Experience with osteoclasis has proved that the temporary pressure on the skin does not cause sloughing, or even an abrasion, and the same is true with this operation.

FIG. 17.

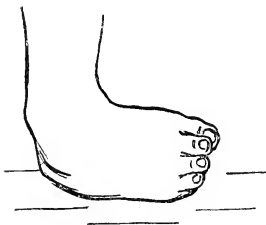

Figs. 15 and 16 show the condition of the foot before and after treatment by this method.

Fig. 17 is a drawing from a cast of a foot in every way similar to the above: the result of treatment by this method is shown in Figs. 18 and 19.

**Tarsal Osteotomy.**—In certain cases the distortion of the bones is so great that no operative procedure directed simply to the ligaments and tendons will be sufficient permanently to correct the deformity; but, fortunately, cases of this kind are rare. To

meet such a condition either osteotomy or resection of the tarsal bones is required. The most important condition lies in the distortion of the as-

FIG. 18.

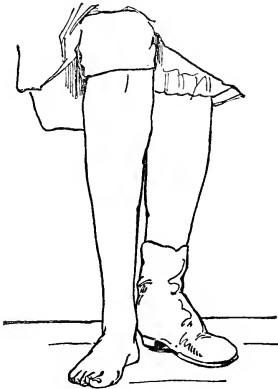

Result, front view.

FIG. 19.



Result, side view.

tragalus, and especially in its neck, and it is against this part that the operation is usually directed.

The simplest way of doing this operation is through an incision down to the bone, from the tip of the inner malleolus to the inner side of the head of the first metatarsal bone, which will be found in severe cases close to the malleolus. The incision is close to and nearly parallel with the tibialis anticus tendon, and in the direction of the metatarsals. The scaphoid will be seen before the astragalus, and will be always first within reach of the knife. The foot is then straightened, which separates the scaphoid from the malleolus, and, if still further straightened, the scaphoid begins to uncover the astragalus, and the neck is seen. A small osteotome is entered on the neck of the astragalus to the distal side of the scaphoid articulation, and the bone divided, or nearly so, after which the fracture is completed by forcibly straightening the foot. The section should be at such a plane that when the equinus deformity is corrected the gap at the section shall be as small as possible. A fixed bandage is then applied, with the foot in a corrected position.

**Tarsal Resection.**—This operation should be resorted to in the most resistant cases only. Excellent results are obtained by this method, and the danger is not great, but undoubtedly both by cuneiform resection and ablation of the astragalus a great deal of bone is removed unnecessarily, and the foot is considerably shortened.

The following methods may be used: enucleation of the cuboid and the astragalus, with or without removal of the end of the external malleolus;

removal by curette of a portion of the astragalus, leaving the cartilaginous surfaces untouched; enucleation of the astragalus, the cuboid, and the scaphoid, or simply of the scaphoid and the cuboid; enucleation of the head of the astragalus, or resection of a portion of bone on the outer side of the neck; resection of the wedge-shaped portion of the bone at the medio-tarsal articulation.

Of these methods but two will be likely to come into general use,—the removal of the astragalus and the wedge-shaped resection of the tarsus. Enucleation of the astragalus is sufficient to enable the foot to be brought to a right angle, except in rare cases where the calcaneus is entered to the posterior surface of the tibia. Supination of the calcaneus can be cured by removal of the astragalus, though in severe cases the end of the fibula must also be removed; but supination of the whole foot is not directly cured by this procedure, although correction by appliance is rendered more easy. In severe adult cases more bones have to be removed.

*Excision of the Astragalus.*—Ablation of the astragalus is best done by Hoehel's method, in which an incision is made back of the external malleolus down to the outer side of the foot, the peroneal tendons divided, and the foot forcibly twisted to the inner side. The astragalus is thus brought into view.

*Excision of a Wedge-Shaped Piece.*—An Esmarch bandage is applied to the foot, and an incision made along the entire border of the foot from the

FIG. 20.

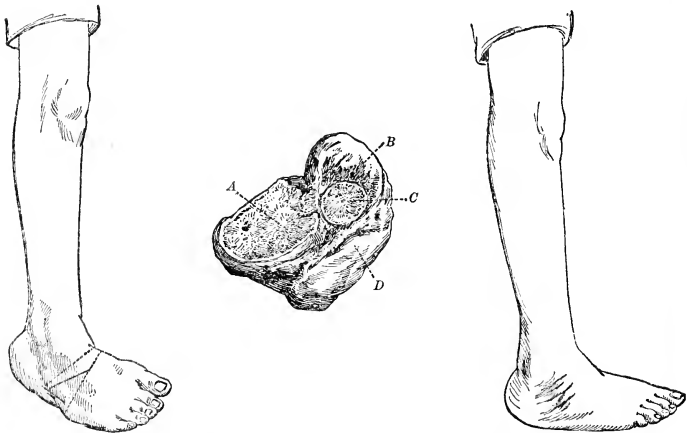

Excision of wedge-shaped piece. (Bryant.)—A, calcis; B, scaphoid; C, astragalus; D, cuneiform.

middle of the os calcis to the middle of the fifth metatarsal bone. This is joined at right angles by another across the dorsum of the foot. (Fig. 20.) The soft parts being reflected, the cuboid is first removed, and a wedge-

shaped portion of the tarsus is then excised, of sufficient size to allow the foot to be brought into position without much force. The wedge, which may be removed with a chisel or saw, should have its base of a width corresponding to that of the cuboid, and should be rather thicker above than on its lower surface.

**FLAT-FOOT.**—The principle in the treatment of this deformity consists in the restoration of the natural arch, but the method of accomplishing this necessarily varies with the case. In acquired forms mechanical means are sufficient in most instances. Whitman advises a light steel plate (Fig. 21), slightly elastic, which reaches from just behind the ball of the great toe, *A*, to just in front of the bearing point in the heel on the inner surface of the foot, *B*. It should run just above the head of the astragalus, *C*, which carries it nearly to the internal malleolus, and extend under the sole of the foot just behind the fifth metatarsal, *D*. The plate must be fitted from a cast of the foot taken with the foot in a restored position. When the weight is put on the properly-shaped plate, not only is the arch of the foot held up, but the inner flange of the plate acts as a lever pressing up against the sustentaculum tali and the tuberosity of the scaphoid.

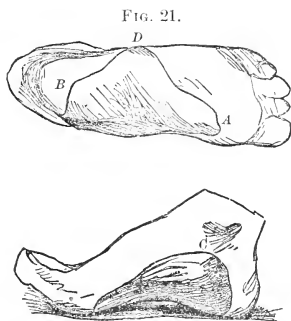

This support is particularly useful in acquired cases in adults, and it has the advantage of allowing natural motion to the foot. Light cases, particularly in children, do very well with a plate of thin steel fitted to the shape of the sole and elevated on the inner border to conform with the normal arch of the foot.

The elastic extension applied so as to support the arch of the foot has been advised by Barwell; but it requires considerable care on the part of the patient, and accomplishes no more than the supports described.

In congenital cases and in some of the severer instances of the acquired deformity, although the same mechanical treatment is required, other means may be necessary to bring the foot into a position in which support would be of value. Forceful restoration of the foot and fixation for a time will be sufficient in some cases. Duchenne thinks that the only muscle which can be contracted is the short peroneus, and that section of the long peroneus in valgus is not feasible. Ogston refreshes the astragalo-scapoid articulation and nails the bones in a corrected position, and Stokes<sup>1</sup> removes a wedge-shaped piece from the inner side of the neck of the astragalus; but it is very seldom that these severe procedures will be required. Usually restora-

<sup>1</sup> Transactions of the Academy of Medicine of Ireland, 1885.



tion of the foot to its normal position, followed by a period of rest and the fitting of some proper support, is all that will be needed.

**VALGUS.**—There are three things to be done in the treatment of valgus, —the elongation of the shortened structures, the overcoming of the distortion, and the promotion of the function of the limb.

In infants manipulation may be all that is necessary, or the foot may be corrected forcibly and retained by plaster until a normal position is obtained, after which a retentive appliance can be worn. These cases, if taken early, rarely give much trouble.

In older and acquired cases a supporting appliance is necessary. It may be sufficient to retain the foot in an inverted position by means of plaster or bandage, but more often some form of external appliance is needed. For this an excellent support is obtained with Taylor's club-foot shoe reversed and applied to the outside of the foot, with a strap passing from the upright round the leg over the internal malleolus and secured again to the upright. By this the eversion of the foot at the ankle-joint can be controlled.

Tenotomy of the peroneus may, however, sometimes be necessary.

**TALIPES EQUINUS.**—It is seldom that the surgeon is required to do more in the congenital cases than to overcome this deformity by simple manipulation or by fixed bandages, although tenotomy will save time.

In neglected and acquired cases section of the tendon and the application of a retention shoe are required.

**TALIPES CALCANEUS.**—In the simple forms of the congenital variety little more is needed than manipulation. If the deformity persists, a retentive appliance which prevents extension to the desired limit may be worn. If the deformity is severe and resistant, tenotomy of the tendons of the anterior portion of the foot, especially the tibialis anticus, may be required. Excision of a portion of the tendo Achillis is of benefit in more advanced cases, although this procedure is by some writers considered unnecessary.

**PES CAVUS.**—Restoration of the foot to a natural position in cases of pes cavus is hardly possible, as they have usually existed for a long time when first seen by the surgeon, and have become very resistant. If restoration be attained by operative means, mechanical treatment will still be necessary for a long time, if not always, as the condition is paralytic in its origin and will tend to recur if the foot is left unprotected. The best form of apparatus is the Taylor club-foot shoe, fitted with a stop-joint the reverse of that used in equinus, if there is much tendency to calcaneus deformity.

# TORTICOLLIS.

By E. H. BRADFORD, M.D.,

AND

E. G. BRACKETT, M.D.

---

**Synonymes.**—Wry-neck, Caput obstipum, Collum distortum; French, Cou tors; German, Schiefhals.

The name torticollis is given to that distorted position of the head in which it is held awry. This condition is either congenital or acquired, and may be constant or intermittent. The affection involves a contraction, tonic or clonic, of the muscles of the neck, usually those of one side alone, but occasionally of both sides. The position of the head varies with the muscles affected, those usually involved being the sterno-mastoid, the anterior edge of the trapezius, the scaleni, the platysma, and the splenius capitis.

Males are more subject to wry-neck than females, and the right side is oftener the seat of the affection than the left. In thirty-seven cases collected by Dieffenbach five were on the left and thirty-two on the right side.

## CONGENITAL TORTICOLLIS.

The true congenital form is very rare. A few cases have been noticed in which an imperfection in the atlas and cervical vertebræ existed, in consequence of which the head was held in malposition. An intra-uterine origin is assumed by some writers, but without other than theoretical reasons. A case has recently been reported<sup>1</sup> of this deformity occurring in a still-born infant, which was caused by a shortened condition of the trapezius and sterno-mastoid muscles, but the distortion could not be entirely overcome until after section of the supra-spinous and interspinous ligaments; but such a condition is one of great rarity, and the author states that no analogous case could be found. One case accompanied by unilateral atrophy of the head has been reported.<sup>2</sup> In a certain number of instances the so-called congenital wry-neck is due to injury at the time of birth, either from forcible stretching of the muscles or from traction in difficult labor, with

---

<sup>1</sup> Archives de Tocologie, 1888.

<sup>2</sup> Boston Medical and Surgical Journal, June 1, 1882.

a rupture of certain fibres of the sterno-cleido-mastoid. Examination will show this muscle to be contracted, and careful palpation will reveal that a portion of the muscle has been torn, and that the spasm of the internal portion gives rise to the distortion.

#### ACQUIRED TORTICOLLIS.

Acquired wry-neck presents several forms, their distinction being based on the etiology rather than on any essential difference in symptoms. These may be classed into spastic, paralytic, compensatory, idiopathic, and those following fracture or dislocation.

The *spastic* may be due to direct nerve-irritation, either central or along the course of the nerve, or it may be the local manifestation of a more general nervous irritation, as in spinal irritation: these, however, are very rare. Arising from a local neighboring disease it is more frequently met with. Conditions causing this are disease of the cervical vertebrae, enlarged cervical glands, deep cervical abscess, etc., being analogous to muscular spasm around other joints.

*Paralytic*.—This form is rarely met with, but may occur from unantagonized muscular action after paralysis of muscles of one side, which may result from central or peripheral cause; but this should not be regarded as true wry-neck. Any deficiency of nervous tone, although not causing actual paralysis, and such as may result either from direct nervous influence or from overwork of one particular set of muscles, may result in a spasmodic condition of the corresponding group from failure of proper antagonism. Several instances of this have been observed.

*Compensatory*.—Various examples of this have been noted where the head has assumed an abnormal position in consequence of some existing inequality or deformity. Instances of this are seen in some lateral curvatures, in which the relation of the head to the shoulders is distorted in the effort to keep the head in an upright position. Wry-neck has also been observed as the result of inequality of the two eyes, although this is usually compensated by accommodation. Quignet has termed this "torticollis oculaire."

*Idiopathic*.—In many cases, such as come under this head, there is obviously no lesion to explain this pathological condition, but it occurs as the result of general malnutrition, having this as a local manifestation. Not infrequently in these cases there will be found a definite exciting cause, such as fright, grief, etc. In this class are also included those acute cases which are due to an inflammatory condition of the muscle itself.

Many of the above causes seem to be but one or more of many factors. In a large percentage there will be found a neurotic family or personal history. The general condition seems also to have a very considerable influence, many cases occurring after severe overwork. Excessive use of the muscles of one side has in several instances apparently occasioned attacks, as in seamstresses who have worked on heavy material, and one case has been reported in a factory-girl whose occupation required her to turn her

head frequently to one side. This position is sometimes assumed when the condition can hardly be considered pathological. Bouvier states that voluntary torticollis is habitually connected with different temperaments, and, in fact, the position is a means of expressing emotion.

#### PATHOLOGY.

In the acute form of torticollis there is nothing to be said as to the pathological anatomy.

In the chronic forms such changes occur as result from long-continued malposition or disuse. Fibrous degeneration, adaptive shortening, loss of tonicity, and over-stretching take place in the muscles, as well as shortening and lengthening of the fascia around the bones. Alteration in size of the bodies of the vertebræ occurs in a certain number of instances, but this osseous deformity is not so common as would be supposed, and is denied by Bouvier.

Other changes noted are cervical spinal curves with a compensatory curve in the dorsal region, shortening and secondary affection of other muscles than those involved in the spasm, asymmetry and difference in length of the clavicles, and asymmetry of the face, the long axis of the face striving, as it were, to gain a vertical position not possible to the head. This gives a deviation of the line of the nose from the ordinary line of the eyes. Furthermore, the two eyes and the two commissures of the lips are not of the same size, the cheek on the contracted side is less prominent, and the features on that side are smaller. This asymmetry diminishes, however, if the deformity is corrected at the proper time. Dubreuil asserts that the cranium itself also indicates a change, and that inequality of the cerebral hemispheres results. Broen concludes from this that a diminution in intelligence would necessarily result; but this is contrary to clinical evidence.

The affection involves essentially, in the great majority of cases, the distribution of the spinal accessory nerve. Conditions causing paralysis of this nerve indicate the same area to be affected, the sterno-mastoid and the upper part of the trapezius, that which passes between the occiput and the acromion. The former receives only a few unimportant filaments from the cervical nerves, while the latter has branches from the cervical and the dorsal nerves distributed to its lower portion. These muscles are most frequently affected, and the sterno-mastoid more frequently than the other; it is, however, rarely affected alone, but, being a terminal muscle, its contraction is more usually noticed than that of the others. Bouvier found that in three cases out of four the sternal branch was the only one contracted. Delore believed that the posterior muscles of the neck were the chief ones affected; and they certainly are affected secondarily, if not primarily.

#### SYMPTOMATOLOGY.

The congenital form is perhaps without exception of the tonic form of spasm. The condition is noticed soon after birth, and the deformity alone

calls attention to the affection. On examination, the sterno-mastoid and possibly a portion of the trapezius will be found contracted, and in cases due to injury of the muscle palpation will often reveal the site of rupture, but later the deformity alone exists. Here a true shortening of the muscle is the cause of the deformity. (Fig. 1.)

FIG. 1.



The usual attitude in the so-called congenital cases.

The acquired form is either acute or chronic. In the acute variety the history is that of acute muscular rheumatism, with some constitutional disturbance. There may be pain in the neighborhood of the affected muscles and their insertions. Any motion, and especially a sudden one, is particularly painful, and to prevent this the head is held rigidly on the shoulders by muscular spasm, the patient turning the trunk and the head together.

The position assumed is essentially the same as in the chronic variety, which is described later. The duration is of a few

days only, but some stiffness may remain for a week or more.

Ordinary "stiff-neck" must be considered as a mild form of this affection, but involving the deeper structures.

The chronic form may develop from the acute, or may be of gradual development from some unknown cause. Congenital cases are also usually chronic.

The position assumed by the head depends on the muscles affected. When the sterno-mastoid is attacked, the ear of the affected side is brought nearer the sternum, the face turned and slightly rotated to the opposite side, and the chin elevated above its normal level. The features may be drawn below those of the opposite side, while in severe and especially persistent cases the jaw is rotated so that the teeth cannot be approximated. In proportion to the extent to which the trapezius is affected the head is drawn towards the shoulder, and when this muscle alone is involved the head is drawn backward and towards the shoulder, which occurs in posterior torticollis, described chiefly by Delore, who declares it to be the more frequent form. In this the other posterior muscles are involved in the spasm. (Figs. 2 and 3.)

Physiologically, the splenius if contracted would draw the head to the side and turn the face to the same side; but this, according to Delore, never takes place in torticollis, and it is therefore assumed that the splenius and the sterno-mastoid never are affected on the same side. When the levator anguli scapulæ is affected together with the sterno-mastoid, there is an increase of the lateral obliquity and of the rotation.

Combinations of different muscles have been observed, but are of infrequent occurrence. Such are a combination of the contraction of different

FIG. 2.



FIG. 3.



Torticollis of several years' duration.

muscles on different sides, a simultaneous contraction of the splenius and the levator anguli scapulae, of the scalenus anticus and the splenius, of the two platysmas, and of the sterno-mastoid on one side and the splenius on the other.

The attitude is the most characteristic feature of this form of the affection. On palpation certain muscles will be found hard to the touch and others flaccid. Bands of contracted fascia are frequently seen in old cases. There is no pain, but attempt to rectify the deformity is painful if persisted in. Rotation of the head is free within certain limits. A deviation of the spinal column—a lateral curvature with rotation—necessarily follows torticollis. In order to retain the head in the vertical position, the patient, unable to twist the cervical spine, will twist the trunk, raising one shoulder, which is accompanied by a complete rotation of the vertebrae and projection of the ribs backward on the concavity of the lateral curve. Although the head is twisted, strabismus rarely results, and although the movement of the larynx in extreme cases is apparently limited by the distortion, the voice is not affected for speech. A slight difference of the surface-temperature has been observed, it being lower on the affected side.

Paralytic cases differ from the above, as the condition is one of un-antagonized action rather than of spasm. The patient cannot move the head nor produce any prominence of the muscles on the paralyzed side. The surgeon can easily correct the deformity, meeting with little resistance, unless the case is of long standing and retraction of tissues on the opposite side has occurred.

A variety of torticollis called by Dally occipito-atloidian has been described, as follows. Its development is usually due to rheumatism. It is

characterized anatomically by a subluxation of the atlas on the occipital bone in such a way that the lateral masses are transverse to the vertical plane. Clinically there is a projection on the transverse process posteriorly. There is a spiral torsion of the head which may resemble muscular torticollis. This may afterwards result in a bony ankylosis.

The spasmodic or clonic form usually begins later in life. It may be unilateral or bilateral, and, as in the other form, there are very slight subjective symptoms, except the pain caused by the cramp. However, there may be occasionally a sense of uneasiness in the back, and later, after the friends have noticed that the head is not held straight, there may be pain near the insertion of the sterno-mastoid. In other cases slight twitching of the muscles is observed for some time previous to an outbreak of the spasmodic condition. In some instances the head can ordinarily be held in proper position, but locomotion, any excitement, or the apprehension of being observed will produce such a contraction of the head that it will be twisted violently to one side and rotated to an extreme limit. A slight pressure of the hand steadying the head will ordinarily correct it, but where the muscular contraction becomes excessive, great force is required to hold it in place. Often there are occasional contractions which are at first partially under the control of the will, but increase in frequency and severity until they cannot be controlled either by voluntary effort or by mechanical force. The annoyance and pain dependent on this spasmodic condition may be so great as to unfit the patient for work and to impair his health to an alarming degree. The motion is one either of rotation, or of rotation combined with depression of the head towards the affected side, and elevation of the shoulder. The rate of contraction varies from occasional contractions to an almost constant one,—in one case eleven in fifteen seconds.

No true picture of the spasmodic variety can be drawn which can in any way be applied to all these cases. The affection may consist of an occasional twitching of the muscles, coming on frequently for some days and then disappearing for several weeks or months. Again, the condition may begin as in the above, and increase gradually or rapidly until the spasm is nearly constant. A clonic contraction may at times become tonic for a while, and this spasm in time change to clonic again; but even in very severe cases there may be complete remission for days or weeks, although this is not common in this class of cases. This form is rare under thirty, and more frequently is found in women.

#### DIAGNOSIS.

There is no difficulty in recognizing the deformity called wry-neck, but the determination of its cause and of the parts involved frequently requires considerable skill. The diagnosis of the muscles affected must be based on an inspection of the position of the head and on palpation.

It is of the greatest importance to distinguish this deformity from other affections which give rise to malpositions of the head resembling it. Such

are cervical caries, enlarged cervical glands, deep cervical abscess, and ordinary stiff neck from cold.

For the diagnosis of torticollis from caries of the spine the reader is referred to the article on the latter disease; but the following points may be mentioned. In caries the head is, as a rule, held more rigidly, and there is greater stiffness of the muscles in attempting to twist it. Ordinarily in torticollis there is no pain nor difficulty when the patient lies down, while in caries (Fig. 4) in the acute stages the patient usually steadies the head with the hand when any motion is required, and there is more pain in the back of the head and shoulders. The facial expression is often suggestive.

In distortion arising from enlarged glands or from abscess the diagnosis must depend on the recognition of their presence.

A diagnosis between posterior muscular torticollis and torticollis due to cervical arthritis is in some cases impossible. In general, however, it may be stated that there is less evidence of contraction of individual muscles or of groups of muscles in the former. The latter is a rare affection.

The recognition of spasmodic intermittent torticollis is, of course, not difficult, but the diagnosis sometimes involves a consideration of the causes which will produce a deterioration of general nervous strength.

#### PROGNOSIS.

Acute muscular torticollis ordinarily corrects itself, though in a few cases it may become chronic. Torticollis due to abscess of cervical glands terminates with the complete discharge of the abscess, as a rule. Intermittent spasmodic torticollis may cease spontaneously, or may, as is more common, remain without change for many years. Congenital forms of torticollis, and the acquired form due to muscular contraction which has become chronic and developed fibrous muscular degeneration, are, of course, incurable without surgical interference. Little or no constitutional disturbance follows this affection, which is more distressing on account of the unsightliness than from any actual discomfort. The deaths that are reported as following torticollis have been in a few instances due to septicæmia following operation.

#### TREATMENT.

The treatment will vary greatly with individual cases, and it is always necessary to bear in mind the cause of the affection to insure any probability of success.

FIG. 4.

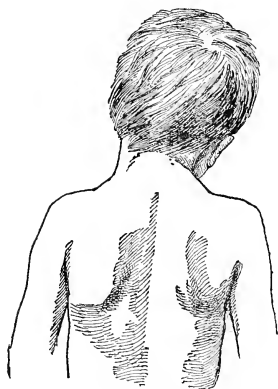

Position in torticollis from caries.



In acute torticollis due to inflammation of the muscles the treatment is largely directed to the alleviation of the symptoms. This is best done by the application of moist heat in the form of cataplasms or poultices and by rest. Oleate of atropine, oleate of morphine, or morphine subcutaneously may be used if necessary. More than this is rarely required.

In all cases the general health should be inquired into, as well as any particular kind of work which would bring excessive use to one set of muscles. In many cases arising from a deficiency of nervous tone, no other treatment than that directed to restoring the health, combined with rest, will be necessary. Such are usually found in overworked adults.

Treatment of cases resulting from caries, from enlarged glands, and from cervical abscess will not be considered, the recognition of the cause being sufficient indication for the line of treatment.

Galvanism to the affected muscles is apparently of benefit in some cases, but these are almost without exception of the spasmodic form, and in patients whose system has been overtaxed, and in whom attention to the general health is fully of as great importance as the local treatment. Some writers deny the advantage of electricity in any case, but the statement is too strong to be fair. In a few cases which were apparently due to faulty antagonism, faradization of the muscles of the opposite side has resulted in a cure.

The treatment of the spasmodic and that of the tonic form differ essentially. For treatment the latter variety is to be divided into two classes,—anterior and posterior torticollis,—the first including those cases in which the sterno-mastoid is the muscle chiefly affected, the second those in which this muscle is involved but slightly or not at all.

The treatment of anterior torticollis is either purely mechanical or both operative and mechanical. Mechanical treatment without the aid of operation is ordinarily unsuccessful, but in a few light cases correction is possible by slight supports which relieve the muscles from the strain of the weight of the head. After complete correction some form of retention appliance is needed for some time, for the purpose of habituating the unaffected muscles to their new functions, and for preventing the patient from assuming the position which has become natural.

The only efficacious treatment of posterior torticollis is that of forcible correction without tenotomy, for the reason that the muscles are too deep or too extensive to be tenotomized. In correcting the deformity the patient should be thoroughly anæsthetized, and an assistant should firmly hold the shoulders, the head of the patient projecting beyond the edge of the table, where it can be grasped by the hand of the surgeon and rotated in all directions. The danger of fracturing the spine is slight, and considerable force can be used. Frequently there are superficial bands of contracted fascia; these may be divided by the tenotome, and all such bands and adhesions as cannot be divided should be stretched by manual force. After the head has been over-corrected and fixed in an over-corrected position, a retaining

appliance should be used. For this purpose a plaster-of-Paris or a silicate-of-potassium bandage may be employed.

For the correction by mechanical means, or retention after correction, the following devices are useful. All have the principle of obtaining a point of fixation on the trunk from which counter-pressure is made on the head, usually on the mastoid or the parietal region or on the jaw, or else by a circular bandage.

The appliance of Buckminster Brown is simple and effective. It consists of a wire collar which has in front a plate so placed as to press the chin to the middle line. Another plate is attached posteriorly, so as to exert pressure behind the ear on the side towards which the head inclines. To the side of the collar is fastened a ring which rests on the shoulder. Behind is an upright, furnished with straps, one of which passes round the body, and one over the shoulder on the side of the deflected chin, and by tightening this pressure is made on the chin and head. This principle is illustrated in Fig. 5, in which the pressure made is the same, but a steel frame is substituted for a wire collar.

FIG. 5.



A simple means is by adhesive plaster and the ordinary roller bandage.

FIG. 6.

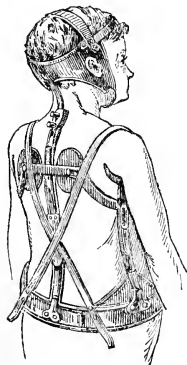

Apply a long strip of adhesive plaster around the forehead and occiput, and make it secure by a bandage round the head, over the vertex and under the chin, pinning these together where the one passes over the other above the ears. Another band of adhesive plaster is carried round the waist, and over this a roller bandage. A ribbon is then fastened to the head-bandage directly above the ear of the unaffected side, and carried diagonally across the trunk to the other side and secured to the waist-bandage.

A similar form of appliance has recently been described by Levrat,<sup>1</sup> in which silicate-of-potassium bandages are wound round the head, one horizontally over the forehead and one vertically under the chin, and at the point of intersection above the ear a bent wire is secured to the bandage. Another bandage is then placed round the body, and the

two are connected by a strap.

Another form of appliance (Fig. 6)<sup>2</sup> consists of a padded metal plate

<sup>1</sup> Medical Record, February 2, 1889.

<sup>2</sup> From Dictionnaire de Médecine et de Chirurgie, 35.

secured to the back by straps beneath the axilla and around the chest upon the shoulder of the side to which the head inclines. From this plate a rod extends up along the side of the neck to the parietal region, with a padded plate adjusted to this part. The lower end is attached by a ratchet and endless screw, by means of which pressure is made upon the head.

Several complicated appliances have been devised which in principle are similar to the one just described, and which have for their object the forcing of the head into its normal position. The head is held firmly by large plates or by a helmet, which is connected with a complicated trunk-piece by leverage. (Fig. 7, A and B.)<sup>1</sup> They are all ingenious in principle, but too elaborate and complicated to be practical.

FIG. 7.

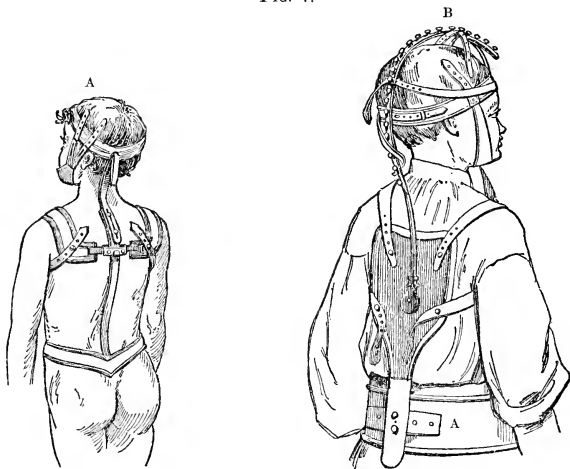

A simple form, useful for mild degrees of distortion or for retention after operation, is shown in Figs. 8 and 9. Support is obtained by two uprights, one extending along the side of the spine, continued over the shoulders, joined in front over the chest, and secured by straps passing round the body. To these is fastened, by means of stout wires soldered at the point over the shoulder, a metal or hard rubber plate, which is so applied to the side of the jaw as to keep the face in the median line, while another plate is made to give support to the mastoid and the surface immediately above.

**Operative Measures.**—Division of the contracted tissues may be done either by subcutaneous tenotomy or by open incision. The advantages of the tenotome are two,—less danger of suppuration, and a smaller scar; but

<sup>1</sup> From Dictionnaire de Médecine et de Chirurgie, 35.

thorough cutting is difficult, and the danger of wounding important vessels in the neck is considerable.

Open incision, on the other hand, allows more bold and intelligent use of the knife, but the disfigurement is much greater, although with adherence to asepsis one may be reasonably sure of union by first intention.

FIG. 8.



FIG. 9.



The division should include tendons of both portions of the sternocleidomastoid, if necessary, and any bands of fascia which prevent the return of the head to its normal position. If subcutaneous tenotomy of the mastoid is to be done, the puncture should be made between the two tendons, close to their insertion. A director can then be passed beneath the sternal attachment until the point is felt projecting beneath the skin on the margin of the muscle. This can be divided with a blunt tenotome, and by a careful sawing motion the tendon is felt to give way. Some surgeons pass the tenotome under the skin and cut downward; others pass it beneath the skin and cut upward. The danger of the latter proceeding is incomplete division; that of the former is division of the deep vessels. The superficial veins are to be avoided by careful inspection before the introduction of the tenotome. The clavicular origin can be divided in the same way, passing the director from within outward. The operation is not devoid of danger: Mr. Erichsen mentions three fatal results.

Dieffenbach operates on the left side in the way just described. On the right he inserts the knife between the trachea and the anterior portion of the muscle, and divides first the anterior portion, then the posterior.

If open incision is undertaken, the ordinary precautions of aseptic sur-

gery should be observed. An incision parallel with the clavicle and an inch above it, reaching across the contracted muscle, should be made, a director passed under the muscles and fascia, and the whole divided with care.

After division of the contracted tissues the head should be kept in a corrected or an over-corrected position, either by a plaster bandage or by some mechanical means, until union of the divided structures has taken place.

FIG. 10.



The accompanying illustrations are of a case treated by open incision, followed by extension in bed, and later by the use of an appliance. (Fig. 10.) In this case the head was drawn towards the left shoulder, and the chin elevated and turned to the right. After operation the child was kept in bed, and, as soon as the condition of the wound would allow, continuous extension by means of weights was made. The arrangement of the straps for this purpose is shown in Fig. 11.

A piece of adhesive plaster was applied to the right side of the face just in front of and above the ear, and to this was attached webbing, *c*, which passed under the chin to the left side. For the correction of the rotation of the face, a strap, *b*, was carried beneath the occiput and secured to the

FIG. 11.

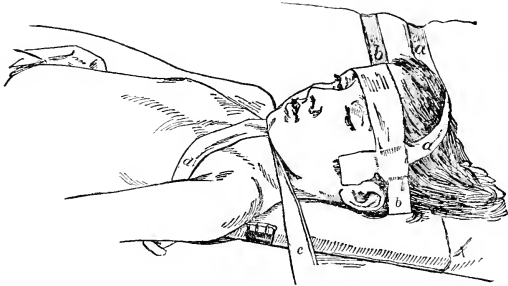

forehead with adhesive plaster, while another, *a*, was passed over the vertex and secured to the side of the face in the same manner. To the end of each strap a weight was attached.

After two weeks of extension, the apparatus shown in Figs. 8 and 9 was applied.

The result is shown in Fig. 12.

In severe cases of *spasmodic* torticollis neurotomy or neurectomy often becomes necessary. Tenotomy, with the rest which follows, affords relief in a certain number of cases, but in cases unrelieved by these means the condition of the patient becomes so serious that extreme measures are justifiable, this treatment being directed against the nerve.

Three courses are open,—nerve-stretching, nerve-division, and nerve-resection. Nerve-stretching has been done a few times, but the results are not encouraging. Probably in cases of this sort requiring surgical interference there is profound central disturbance, which requires complete paralysis of the nerve to put an end to the irritative condition.

The situation for reaching the spinal accessory nerve is along the anterior border of the sterno-mastoid. The nerve enters the muscle obliquely about an inch and a half below the mastoid process, and can be found by an incision in this situation. An aid in finding it (Richardson) is to scratch with a director the tissues at the bottom of the wound as the dissection is made, by which the nerve is irritated into causing a contraction of the muscle.

Annandale operated through an incision three inches long commencing at the lower border of the mastoid process and extending along the anterior border of the muscle. Southam exposed the nerve in the posterior triangle by an incision two inches in length along the posterior border of the sterno-mastoid muscle, with the centre on a level with the upper border of the thyroid cartilage. Beneath the fascia the nerve was found running obliquely downward and outward to terminate in the trapezius. This operation was for nerve-stretching; but some operators have advised this site for first finding the nerve.

FIG. 12.



# ACUTE INFLAMMATION OF BONE.

By WILLIAM MACEWEN, M.D.

---

HEALTHY bone, in children as in adults, is itself an insensitive structure, whose function is in the main purely mechanical. Its formative stage, the deposit of calcareous salts in the matrix, fibrous or cartilaginous according to situation, is in progress in one portion or another of the skeleton, from its commencement in the clavicle at about the end of the first month of foetal life, until adult age is fully entered upon, and the epiphyses and diaphyses are thoroughly consolidated with one another. The precise period of this completion varies in different individuals.

The process of inflammation in bone is similar to that in the soft tissues, being modified, however, by the peculiarities of the structure. In bone the vessels of the abundantly-cellular medulla and those of the Haversian canals and the periosteum play the chief part in inflammation. When inflammatory action originates in any part of a bone, all the other parts participate in the action, and, though the terms periostitis, osteitis, and endosteitis are used to denote the part where the inflammation is chiefly located, it must be understood that the contiguous structures are likewise involved, though to a less degree. Further, inflammation originating in one part may induce destruction in other parts, as in the case of periostitis inducing necrosis. Bones which ossify in membrane are by no means so liable to acute inflammatory diseases as those which ossify in cartilage. In childhood the bones are far more vascular than they are at a later period of life, and especially so at their epiphysial extremities, where the active processes of osseous formation are taking place. It is during this most active developmental period that bones are most apt to become affected with acute osteitis and with the slower invasions of tubercular disease, and these diseases attack most often the growing extremities of the diaphyses, the tubercular disease attacking also the epiphyses.

Acute inflammatory action commonly arises in the diaphysial extremities of the long bones in childhood. The osseous tissue is here in process of active development, the cancellated tissue abounding in blood-vessels: hence when inflammation occurs it quickly involves the surrounding soft bony tissue along with the medulla. The inflammatory products thus formed do not spread into the epiphyses, as the epiphysial disk of cartilage prevents

that, and owing to the manner in which the periosteum is attached to this disk of cartilage the inflammatory products are guided into the subperiosteal areolar tissue. When inflammation once involves this tissue, it spreads with great rapidity over the whole shaft, stripping the periosteum from the bone. It does so the more readily as there exists a minute interval between the periosteum and the bone, filled with loose connective tissue, along which inflammation travels with great rapidity, as it does in somewhat similar structures, such as the areolar tissue of the pelvis in pelvic cellulitis. Occasionally, especially when the inflammation in the bone is less acute, the periosteum may become soldered to the bone for some distance round the epiphysial lines, in such a manner as to shut off the periosteal areolar tissue and to protect it from the invasion of the purulent extension issuing from the diaphysial side of the epiphysial cartilage. The inflammatory products in such cases escape by ulcerating directly through the periosteum opposite to the epiphysial line. This is somewhat similar to what takes place in serous cavities such as the pleura, where an inflammatory action in the lungs occasionally sets up adhesions between the visceral and parietal layers, when, should there be a cavity in the lungs containing pus, the latter would not be apt to occasion empyema, though the pus might make an exit externally directly through the chest-walls. The neighboring articulations are seldom involved primarily in acute periostitis, as the attachment of the periosteum to the epiphysial cartilage prevents this. The epiphysis, receiving its blood-supply independently of the periosteum, continues to live and grow. The diaphysis, deprived of its periosteal blood-supply, may become necrosed, though necrosis does not necessarily follow. Inflammation may, however, attack the centre of epiphysial ossification during infancy, before the epiphysial disk of cartilage has been formed. When this occurs, the neighboring joint is apt to become involved, this portion of bone being covered with synovial membrane.

*Abscess in Bone.*—Occasionally the pus formed at one of the diaphysial extremities of a bone remains pent up in the medulla and in the cancellated tissue of the shaft, forming an abscess in the bone. The pus may be strictly localized, or the whole medullary cavity may become converted into an abscess. It often remains for years pent up in the interior, a thick pyogenic membrane forming a lining to it. The bone externally becomes greatly thickened and frequently sclerosed. Abscess in bone is more apt to form in chronic or subacute inflammation, though there are cases where the abscess-formation is ushered in by quite acute symptoms, oftentimes attributed to some general constitutional disturbance, and only long after explained by the finding of the abscess on drilling the canal.

Acute periostitis does not always originate in the diaphysial extremity of a long bone. The inflammatory action may occur initially in the periosteum, in which case the diaphysial extremities of the long bones are not involved at the beginning of the attack, though they may subsequently become so.



Acute periostitis is by no means uncommon in early life, being most frequently seen before puberty, but occasionally occurring during adolescence and even later. It is often accompanied by osteo-myelitis, though it may be impossible to differentiate the latter at the outset of the attack.

**Causation.**—Its exciting cause is a blow or knock, often so trivial as to leave but a faint impression on the patient's mind, and so slight that it could scarcely cause an appreciable physical detriment to a healthy person. The predisposing cause is a lowered state of vitality, the patients usually being weak, pallid, poorly nourished, and living in bad hygienic conditions. The exanthemata occasionally are followed by acute periostitis leading to necrosis, but the inflammation thus induced partakes more frequently of a chronic or subacute character, and it is often localized, not involving the whole shaft of the long bones. The convalescence from enteric fever is often interrupted by periostitic formations, leading to necrosis. It also happens that acute osteitis and periostitis are more prevalent during or immediately following epidemics of the exanthemata, especially enteric fever, scarlet fever, and measles. Probably these affections, by reducing the patients' strength, render them more susceptible to the immediate cause of the periostitis.

Cases of acute periostitis have frequently presented themselves to the writer in groups of three, four, or five, occurring within a fortnight of one another, raising the suggestion of germ etiology, which is strengthened by the whole course of this acute affection and by its rapid constitutional involvement, and further supported by the demonstration of micro-organisms in the shape of staphylococci and streptococci in the pus removed from the bones and from under the periosteum. The early history of these cases shows that there is an interval of days between the slight injury and the onset of the acute symptoms, sufficient to enable germs already in the circulation to be poured into the damaged tissue, in the blood-clot of which they find a nidus, abundance of food for their development and proliferation, and numerous blood-channels through which the reinvigorated germs may find ingress to the circulation and become scattered broadcast throughout the body. Such attacks are often ushered in by symptoms which have led the parents and medical advisers to the opinion that they were dealing with one of the exanthemata, and occasionally such patients are admitted to the fever hospital certified as cases of measles.

**Symptoms.**—The attack is frequently preceded by headache and ushered in by vomiting, rigors, drowsiness passing into delirium, and high fever, ranging from 103° to 106° F. These follow one another so rapidly that in both children and adolescents the delirium may supervene within a few hours of the rigor. Other toxic symptoms may appear, such as anomalous rashes of a dull, diffuse, measly type, most marked on the extremities and trunk, though occasionally seen on the face, which is, however, free from indications of coryza. There is low muttering delirium, alternating with screeching-fits induced by pain in the affected bone and periosteum, or by secondary involvement of the joints, kidneys, pleurae, or pericardium.

During all this time the patient, especially if a young child, may not have referred or directed particular attention to the seat of the disease, and if this be not done at the outset it is often masked by the subsequent involvement of other parts and the clouded mental condition of the patient. In some cases the delirium and the screeching-fits have been erroneously attributed to meningitis, and in others to excessive irascibility. That mistakes may be made in overlooking acute periostitis cannot be wondered at when one knows that the local phenomena are not so obtrusively prominent at an early stage as to arrest attention unless specially looked for. Descriptions of the local appearances are generally given by hospital surgeons under whose notice such cases come at a late period of the disease, when the manifestations of its presence are pronounced, while at an early period the symptoms must be searched for.

When one recollects that the whole process occurs under a dense membrane, little swelling of the limb will be expected. The superficial tissues are not reddened and may not participate in the subperiosteal inflammatory action, though when the affected bone is superficial, such as the tibia, œdema of the superficial soft tissues is the rule.

There is one symptom which is always present in the early stage and which persists throughout the case and may even be elicited when the patient is plunged in a state of low muttering delirium,—that is, pain on pressure over the affected part. Even when the patient is quite unable to answer questions, and is lying in a drowsy, dazed state from toxic influences, firm digital pressure over the affected part will be answered by a sharp expression of pain and often by attempted withdrawal of the limb. In doubtful cases, when the patient is either partially or wholly unconscious, the bones in the body should be carefully and systematically gone over, commencing with the tibiæ, which are most often affected, the femora next, then the bones of the upper extremities, and so on over the body. When firm digital pressure is exerted on the part affected with acute periostitis, the response to the pain produced is immediate,—like placing one's finger on the button connected with an electric bell. When a long bone is affected, pressure upon any part of its diaphysis is generally sufficient to elicit this symptom, yet, if not at once brought out, it is better to run the whole bone over, lest the affection be of limited localization. This is especially needed in conducting examinations at an early period of the disease.

The femur lies so deeply that special care is required in conducting this examination upon it. In one instance an adolescent was sent to the writer's care by the sanitary authorities of Glasgow, to whom the case had been reported as one of fever with an anomalous rash. The patient presented all the general phenomena of acute suppurative periostitis. She was in a state of muttering delirium from which she could not be roused, and therefore she could not give any voluntary guidance as to the locality of the disease. It was only after the most deliberate examination that the painful area was detected at the intertrochanteric line and neck of the left femur. When

once found, deep pressure always produced the cry of pain, though pressure over other portions of the shaft did not elicit any complaint. The contour of the two limbs was identical. There was no swelling, redness, nor œdema to be discovered externally on the affected limb. The incision through the soft parts to the bone displayed perfectly healthy tissues until the periosteum was incised, when pus issued and the bone was seen to be bare and probably the seat of osteo-myelitis.

On another occasion a child was admitted into the Glasgow Fever Hospital certified as a case of fever. She had periostitis of the left tibia, and was quite insensible and *in extremis*. So little swelling was there over the tibia that several observers whose attention was directed to it hesitated to pronounce it in any way different from its neighbor. Even when the two limbs were placed side by side the difference, in the writer's opinion, was just perceptible to the eye. Pressure over this bone produced the instantaneous screech, which similar pressure on any other part of the body failed to do. The patient died within a few hours of admission. The periosteum as seen post mortem had lost none of its tenseness. It was stripped from the whole tibial diaphysis by a thin layer of semi-purulent exudation about a thirty-second of an inch in thickness, swarming with staphylococci, large patches of which occupied the field in many places. Organisms of decomposition were of course also present.

*Subacute Cases.*—In the subacute cases of this disease the progress of the inflammation is slower. The patient retains consciousness and localizes the seat of the affection, the pain causing him to be clamorous for relief. At a late period of the periostitis the swelling of the limb is marked both by periosteal distention and by superimposed œdema. Still later the pus may ulcerate through the periosteum and escape into the soft tissues, when the swelling is increased, the external tissues become reddened, and the limb may even assume the aspect of cellulitis.

In abscess of bone when the acute period is past, dull aching pain is felt, generally with slight increase of temperature, and there is an increase in the size of the bone and also in the sensation of weight the patient experiences.

*Necrosis following Acute Inflammation of Bone and Periosteum.*—It is sometimes asserted that the underlying shaft when stripped of its periosteum is sure to die. This is erroneous, as necrosis does not necessarily follow. Some surgeons believe that necrosis of the whole diaphysis occurs only when osteo-myelitis accompanies the subperiosteal abscess. Yet this is not wholly correct, for there are cases where total necrosis occurs after acute subperiosteal abscess without osteo-myelitis. In such cases as are being dealt with, diaphysial necrosis occurs in two ways. First, in acute osteo-myelitis, either by the intensity of the osseous inflammatory action causing a rapid proliferation of cells, which fill up the Haversian canals and occlude the vessels contained therein, the stasis of the blood in the latter favoring the occlusion, or by embolism of the minute osseous pro-

duced by micro-organisms which swarm in the medulla and spread into all the more vascular parts. Second, by sudden deprivation of blood, asphyxia, occasioned by separation or occlusion of the nutrient vessels and the simultaneous removal of the periosteal blood-supply. Although the bone becomes necrosed in each case, the appearance which it presents varies according to the cause. Where the necrosis occurs from the first cause, the osseous tissue is engorged with vascular elements, it is dark-colored, the medulla being of chocolate hue, and the probe emits a dull note as it strikes against its outer shell. Putridity is prone to ensue, and the odor can be subdued only by removal of the mass of necrosed bone. Ultimately it assumes a dark-yellow color, even when sheathed in the healthy unwounded tissues, and after exposure by an opening rapidly turns black. The necrosis which occurs from the second cause is quite different: the shaft is white, avascular, and emits a clear ring under the probe. There is little if any fetor when first exposed, and when present it is easily removed by free aseptic ablation. The analogy to the moist and dry gangrene of the soft parts is clear.

In dealing with acute periostitis it must ever be borne in mind that the long bones receive blood from both the periosteum and the nutrient vessels, the latter affording the most direct and abundant supply. When the periosteal blood is cut off from the diaphysis and the nutrient arteries remain intact, total necrosis does not occur. Superficial necrosis may do so, in the shape of exfoliations, though in many such cases the vitality of the bone is completely preserved. Total necrosis occurs when from any cause the nutrient vessels become occluded (thrombosis or embolism) or ruptured, and when at the same time the periosteal blood-supply has been removed. In the majority of cases of acute periostitis the nutrient vessels remain intact, and only partial necrosis in the form of exfoliation occurs. In a minority the nutrient vessels are destroyed: this generally occurs at a late stage of the disease, by extension of the inflammatory action causing thrombosis or softening.

It is desirable in any case of acute subperiosteal inflammation to ascertain whether the nutrient vessels remain intact. This may be done in either of two ways. First, at the time of relieving by incision through the periosteum the pent-up inflammatory exudation, the probe, or the finger where possible, may be carefully inserted under the elevated periosteum to the position where the main nutrient vessels enter the bone. If the fold of membrane enclosing the vessels be found intact, it is clear that separation has not occurred, and the probability is in favor of their lumen being patent. Thrombosis, however, may have occurred. Such an examination must be carried out with the greatest gentleness, or the parts which ought to be preserved may thereby be detached. The slower and safer method is to observe the conduct of the denuded bone, which, though when first exposed by the incision made for the relief of the inflammatory exudation it shows an avascular, white, polished surface, yet, when the nutrient vessels are preserved, after the lapse of a few days presents a blush of life, and soon

after becomes roseate, the vessels springing from the deeper layers ultimately throwing out granulation-tissue, part of which forms a new periosteum. In the contrary case, where the vessels have become occluded or separated, the bone remains opaque white, gradually changing to a yellowish neutral tint if the purulent secretion is allowed to decompose.

It is fortunate that in the great majority of cases the nutrient vessels are not destroyed, or that, when they are, their destruction is consummated only at a late period of the disease. When their destruction is effected at the outset and synchronously with the complete separation of the periosteum by acute suppurative periostitis, and when both results are sudden and complete, not only does total necrosis occur, but there may also be no bone-reproduction. When the process of the inflammation has been slower and the osteoblasts have been poured out in great numbers from the Haversian canals into the periosteum before the separation of the latter, or when those already existing on the under layer of the periosteum are not subjected to a destructive degree of inflammation, the reproduction of bone is assured, even in total necrosis, the diaphysis becoming buried in a peripheral layer of new bone which grows inward as the necrosed bone becomes absorbed. So that the consequences of this acute periostitis may be divided into three groups: first, where there is no necrosis, or only superficial exfoliation; second, necrosis of the diaphysis, with complete subperiosteal restoration of the shaft; and, third, not only total necrosis, but also destruction of the osteoblasts in the periosteum, and consequent permanent ablation of the bone.

*Non-implication of Epiphyses of Joints.*—The epiphysis seldom becomes involved in the necrosis, and, when it does, the corresponding joint participates in the suppurative action, which often leads to destruction of the articulation. The inflammation is then very acute. The neighboring joints are often affected with synovitis of a simple kind, which disappears rapidly when the acute inflammation under the periosteum has subsided. Pyæmic involvement of the joints also occurs as a secondary effect, and any of the articulations may be involved. When pyæmia attacks the system, the evidences of it will be looked for in the internal organs. Short of pyæmia, serous effusions frequently occur into the pericardium and pleuræ.

*Prognosis.*—The prognosis of acute diffuse periostitis and osteo-myelitis is always serious. If permitted to run their course uninterruptedly, these affections are generally fatal from systemic involvement. In forming a prognosis an examination of the internal organs ought to be made for evidences of pyæmia or septicæmia, which, if present, contribute greatly to the gravity of the case. Pericarditis and albuminuria are serious complications.

Regarding the local affection, though the bone be stripped of its periosteum, yet if the nutrient vessels be sound the bone will probably live. If both sources of blood-supply be cut off, the bone will necrose, and when the periosteum and the bone become necrosed there will be no new

bone-formation, and a defect in the continuity of the bone will result. When, however, such cases are seen at a very early period and promptly treated, much may be done to avert the more serious consequences both to the life of the patient and to that of the bone. In some such cases the malady has been actively treated by incision at a period when the inflammatory products, though containing pus, were chiefly composed of leucocytes, after which not only did the patient promptly recover, but the localized affection also rapidly disappeared, leaving no subsequent trace of its presence except the linear cicatrices made for its relief. There was not even an appreciable thickening of the bone.

**Treatment.**—In acute suppurative periostitis free aseptic incisions through the periosteum are to be made *as soon as possible*: first, to remove the pus filled with micro-organisms, and so to prevent septicæmia and pyæmia; secondly, to allow the periosteum to fall into its normal position relatively to the bone, and so to restore its functions; thirdly, to diminish the intense pain suffered. After the free incisions have been made in the long axis of the bone, an antiseptic douche ought to be applied, in order to clear away the whole of the subperiosteal pus, and, if possible, to render the parts aseptic. Delay in freely incising the periosteum, while leeches and fomentations are applied, means disaster. It is better even to err by making the incision too soon than to make it too late. When all the pus has been removed, antiseptic dressings ought to be applied.

As a rule, this proceeding is followed by a rapid reduction in temperature when the case is distinctly local and when there is no osteo-myelitis of a pronounced kind. When the temperature has not been greatly reduced within the first forty-eight hours, inquiry ought to be made regarding the possible involvement of the lungs, heart, and kidneys, and also the joints. If all these are free and the high temperature persists, in the absence of pockets containing pus, there is a probability of osteo-myelitis, which is generally accompanied by a dull aching pain in the bone. When osteo-myelitis is present, the bone ought to be freely drilled, so as to expose the medullary canal and permit the inflammatory products to escape. In order to preserve the epiphysial cartilage and the epiphysis itself from inflammatory invasion, which is apt to occur by extension from the pent-up inflammatory products in the vicinity, the diaphysial extremities ought to be perforated near to, but not involving, the epiphysial lines.

After the relief of the periostitis the exposed bone ought to be carefully protected, and occasionally closely scrutinized, with the object of noting its behavior. As long as there are any signs of vitality it ought to remain undisturbed. Even when appearances indicate the probable death of the bone, this may be only partial and superficial, and while preserved aseptic it is well to allow it to remain until fresh bone be developed in the vicinity of the old. Exfoliation and sequestra may form, and yet there may be a considerable framework of bone left, sufficient to preserve the continuity of the shaft. When it is evident that total necrosis has

occurred, it is well to delay removing the shaft for at least several weeks, until a new shell of bone has formed in the periosteum and until there has been a line of granulation-tissue formed between the epiphyses and the shaft, when the shaft may be levered out of its position with the least possible disturbance of the epiphysial extremities.

In those unfortunate cases where the osteoblasts and the bone have perished by the intensity of the inflammation, and no bone-reproduction takes place, after removal of the bone and the products of decomposition it is best to allow the wound to heal, to restore the health of the patient, and subsequently to build up a new bone from fresh osseous grafts. In the mean time there may have been some slight osseous reproduction from the epiphyses, but, as a rule, this is so slight as not to be of practical value. In order to prevent shortening of the limb until the grafting has been completed, extension should be maintained, especially when the femur or the humerus is involved.

# LATERAL AND FUNCTIONAL CURVATURES OF THE SPINE.

BY V. P. GIBNEY, M.D.

---

**Definition.**—A deviation of the spinal column to one or the other side, frequently accompanied with rotation of the bodies of the vertebræ on the vertical axis, is what the profession generally understands by the term lateral curvature of the spine.

The effort made by the patient to maintain a vertical bearing very early converts a single curve into three, giving primary and compensating curves. One seldom, therefore, finds less than a letter S, more or less perfectly formed, as the shape which this deformity assumes.

Functional curvatures represent antero-posterior and lateral deviations, with or without compensating curves. The rotation element in this class is absent. The term functional is in this connection very nearly synonymous with compensatory. The deviation depends upon the interference with function in certain organs, and is remedied when the function is restored.

**History.**—Spinal curvature was divided by Hippocrates about the year 400 B.C. into *cyphosis*, *lordosis*, and *scoliosis*. Curiously enough, the latter term is the most scientific at the present day. While references may be found in the works of Ambroise Paré, 1650, and in those of Glisson about the same time, nothing of special importance pertaining to this deformity is found in medical or surgical writings until the beginning of the present century.

Rotation of a vertebra was first alluded to by M. Le Clercq in 1710. This reference was in a work entitled "The Compleat Surgeon." In 1824, Andrew Dodds, of London, developed this idea, and gave to lateral curvature the name of rotated or contorted spine. In the same year Rogers Harrison, in a work on "Deformities of the Spine and Chest," wrote as follows: "To conceive the cause of this extraordinary derangement it is necessary to imagine that, in a well-marked curvature of the spinal column continuing to sustain the weight of the body, the vertebræ of the middle of that curvature are, in fact, in the same situation as if they were urged by a direct and horizontal force on the side of the concavity towards that of the convexity. In this impulsion the body of the vertebra, isolated in its anterior and lateral parts, experiences no resistance, but the articular processes are powerfully restrained by their reciprocal connection. The



transverse processes find in their articulation with the tuberosities of the ribs a resistance to their deviation, which would be very weak on the part of an isolated rib, but which becomes considerable by its union with the adjoining ribs. It results from this exposition that behind the central part of the dorsal column there is efficacious resistance to its lateral displacement, and, consequently, the vertebra must necessarily turn on its axis to arrive at the position which observation so frequently presents."

In presenting the history of the deformity under consideration, it certainly seems necessary to give space to this theory, and at the same time to refer my readers to the ingenious contrivance of Dr. Judson presented to the Academy of Medicine in 1876. Cuts of this device have been so often reproduced that I take it for granted that all are familiar with its appearance. It consists simply of vertebræ placed in normal position over a flexible rod, of which the lower end is fastened to a board and the upper end passes through a hole in a board parallel to the lower board, pressure on the top of this rod downward giving a deflection of the column to one or the other side, which deflection is combined with rotation.

The most exhaustive treatise on lateral curvature is by Mr. William Adams, of London, the first edition of which was published in 1864. The history of the suspension treatment dates as far back as 1650, when Glisson's work "De Rachitide" was published. Glisson's swing was for many years popular in Germany and England. It is not strange, therefore, that this method should be revived from time to time. To the late J. K. Mitchell, father of one of America's most distinguished physicians, we are indebted for the introduction of the suspension treatment of spinal curvature into this country.

**Etiology.**—The dorsal region is more frequently the seat of deformity, and the convexity, as a rule, is towards the right. A much smaller proportion of cases present the primary deformity in the lumbar region, and a still smaller proportion in the cervico-dorsal: these are usually to the left. In the *Centralblatt für Chirurgie*, No. 21, 1886, Kölliker, in an analysis of seven hundred and twenty-one cases, found four hundred and sixty-six single curves, three hundred and ninety-one of which were dorsal. Two hundred and eight of this number had the convexity to the right, and one hundred and eighty-three to the left. There were two hundred and twenty-two double curves, one hundred and seventy-two of which presented the convexity to the right in the dorsal region, and to the left in the lumbar. Without making an analysis of the cases that have come under my own observation, I am fully prepared to accept the statistics of Kölliker as reasonably accurate.

Sex seems to be a predisposing cause, as we find the deformity more frequently in girls than in boys, the proportion being about four to one. Ketch, of New York,<sup>1</sup> found one hundred and eighty-nine females to forty

<sup>1</sup> Medical Record, April 24, 1886.

males, and Kölliker, of Leipsic, five hundred and seventy-seven females to one hundred and forty-four males.

The above statistical references lead naturally to a consideration of predisposing causes. The profession, in this country at least, is indebted to Dr. Ketch for calling attention to the frequency with which curves are seen in infants and young children. The general impression is that curves develop most frequently between the ages of eight or ten and fifteen years. My own experience coincides with this impression, although a certain proportion develop in infancy. The claim is made that mothers and nurses are so defective in their powers of observation that many infantile curves are overlooked. I am not satisfied that this is true. The mother, in my experience in both private and dispensary practice, is, as a rule, quite observant on this point. Occasionally, however, I have asked her how she happened to observe so slight a deviation in a baby, and the answer has been that some relative or intimate friend of the family had such a curve, and in this way her attention had been directed to the subject. It is certainly gratifying to the orthopædic surgeon to find a more general interest, in both the medical and the lay mind, in deformities and joint-diseases. The result is that many cases in their incipiency come under treatment, so that our concern is to prevent, rather than to correct, deformity. Age, therefore, is a predisposing cause.

Congenital asymmetry is regarded by some German authors as a predisposing cause, yet this certainly lacks demonstration. Muscular weakness, which is so common in the wake of certain fevers, is one of the most prominent of the predisposing causes.

So far as my own observation goes, rickets takes the leading place in the way of predisposition. Reasoning *a priori*, one can readily see how important a cause this defect in nutrition may be. There is a lax condition not only in the soft parts, but also in the osseous. The flabbiness of muscles, the laxity of ligaments, the epiphysial enlargement, and the general lack of bony hardness render the child incapable of withstanding the slighter traumatism of infancy. When one considers the normal symmetry of the spinal column, how accurately the lamina of one vertebra fits upon the lamina of another, and how essential it is to preserve this symmetry during the period of development, it becomes all the more remarkable that lateral curvature is not of more frequent occurrence. It is hardly fair to assume that rickets is more prevalent now than formerly, but it is fair to assume that it is more frequently recognized. The profession in general has become so well informed on this subject that one no longer looks for rickets among the poor alone, but finds it very frequently among the upper walks of life. Any inequality, therefore, in the articular facets of the vertebra will predispose to lateral curvature; this inequality may be induced by position long maintained or by traumatism. A striking analogy may be had in rachitic knock-knee and bow-leg. (See Fig. 1.)

Some writers on this subject attach much importance to an inherited

diathesis, as predisposing to the deformity under consideration: I do not believe, however, that diathesis

FIG. 1.



Rachitic scoliosis in a case of genu valgum.

plays any important part. I am quite willing to admit that an acquired diathesis—or, rather, a cachexia produced by long illness or by poor hygiene—does take an important place in the list of predisposing causes. I wish here to make a distinction between hereditary diathesis and heredity. By the former is meant scrofula, or, to use a more modern term, tuberculosis, while by the latter is meant the transmission of a deformity direct. We are all more or less familiar with cases occurring in two or more members of a family while the mother or the father also presents a similar deviation from the normal. I have at present under observation two daughters in one family, one of whom has a marked rotary lateral curvature, the other a slight one, while the mother herself presents a rotary curve in the lumbar region.

The exciting causes in the order of their prominence are as follows: *weight*, *static*, *inflammatory*, and *neurotic*. By

*weight* is understood the superincumbent weight of the body acting, by reason of faulty attitude, in a direction not in the line of the vertical axis. Faulty positions in sitting or standing, that become habitual, are among the most frequent conditions producing a curvature. One can readily see how a boy or girl at school may assume these positions quite unconsciously because of impaired health or lack of symmetry in the laminae or articular facets. Before public attention was so forcibly called to school hygiene, the construction of the benches, chairs, and desks was so faulty that children were often compelled to take awkward positions in order to secure rest. Fortunately, in the more enlightened schools of the present day this necessity seldom exists.

Another cause which may be properly classed under the weight theory is vocation. By this is meant the more constant use of one side of the body, supplemented by the employment of a greater or less amount of strength. This, of course, develops the muscles of one side to excess, and curvature becomes quite easy of production, especially when the predisposing cause exists. After ossification is complete, these vocation scolioses are less apt to occur: hence the importance of a full knowledge of the danger of requiring of children any prolonged occupation. (Fig. 2.)

By static is understood a cause which depends upon unequal length of

PHOTO. 1.



SHOWING SCOLIOSIS FROM SHORTENED LIMB.

PHOTO. 2.

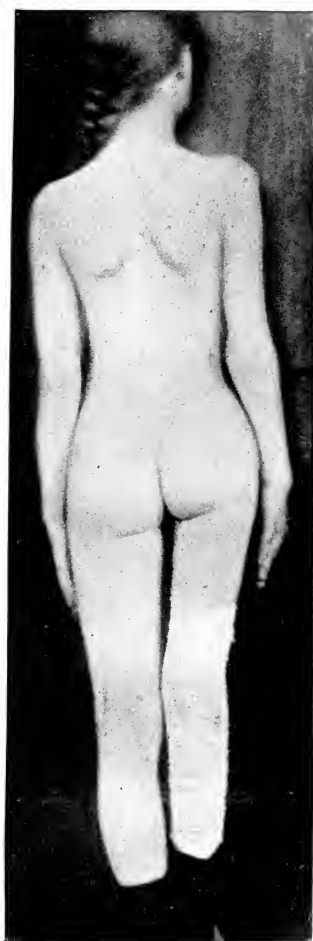

SHOWING SCOLIOSIS CORRECTED BY EQUALIZING THE PELVIS.

of the  
some  
Al  
scific  
functio  
Am  
rine aff  
tory con  
as a rule  
tance in  
(Fig. 3.)  
nearly  
material  
to the 10

the lower extremities, or upon unequal functional power. Photos. 1 and 2 are from photographs of a patient now under treatment for disease of the hip, third stage, with shortening. Photo. 1 shows the deformity as she attempts to place both feet on the floor. Photo. 2 shows the deformity of the spine corrected by bearing her weight on the left—the sound—limb. (The bandage on the right limb was applied for the retention of adhesive plaster, and is nothing pathological.) The pelvis itself may be oblique, and hence the column above it is deflected even where the limbs are of equal length, so that there is practically a crural asymmetry. Some writers describe a curvature dependent upon this cause as incidental. In affections

FIG. 2.

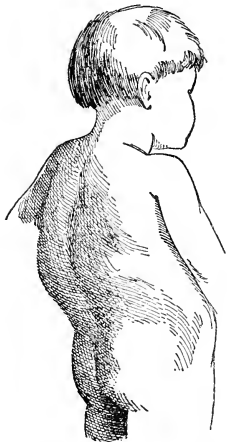

Rachitic scoliosis to the left, with cyphosis.

FIG. 3.

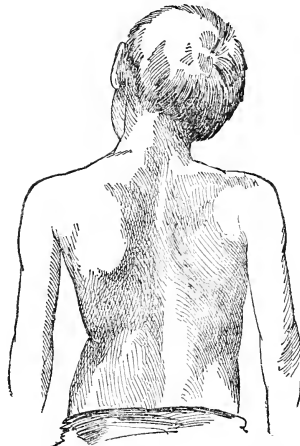

A case of torticollis showing cervico-dorsal scoliosis.

of the hip where the function of the joint is for a long time impaired, we sometimes find a curvature which is known as static.

Albert and Nicoladini have described cases of scoliosis that depend upon sciatica, and we can readily understand how prolonged impairment of the function of a limb thus affected could produce a lumbar deviation.

Among the inflammatory causes we have torticollis, cicatrices, and pleuritic affections, notably empyema. In recording wry-neck as an inflammatory condition, I desire to explain, as follows. Congenital torticollis is due, as a rule, to a hæmatoma of the sterno-cleido-mastoid, and about this blood-tumor inflammatory changes take place, resulting in shortening of the muscle. (Fig. 3.) In acquired torticollis, malaria and rheumatism figure most prominently. I am quite willing to admit that the torticollis which results from malarial poisoning is neurotic in character. Authorities differ somewhat as to the locality of the lesion,—as to whether it is in the nerve or in the

muscle. A mild grade of myositis is often recognized in rheumatism. Rheumatism most commonly invades the fibrous structures, and rheumatic torticollis is usually regarded as a cervical peri-arthritis, directly implicating the nerves in their course to the different groups of muscles.

FIG. 4.



Scoliosis from empyema.

With the deformity which results from empyema we are all more or less familiar. A curvature results by reason of impairment of function of one side of the chest, with corresponding increase of function of the other. (Fig. 4.)

The deformity in empyema is a pure lateral curve, with very little of the rotary element. Not only is the chest-wall expanded on the convex side, but the column itself is also drawn in this direction. The curve is generally easy of correction, and the usual form of brace is well adapted to an empyemic lateral curvature.

rection, and the usual form of brace is well adapted to an empyemic lateral curvature.

FIG. 5.



A scoliosis dependent on myositis ossificans. The right arm is raised from the side to the full limit, the resistance being due to ossification of the tendon of the latissimus dorsi.

In certain forms of rheumatism—the arthritis deformans, for instance—the curve sometimes occurs as a result of muscular shortening or spasm.

I distinctly remember a curvature which developed as a result of myositis ossificans in a case that I presented to the Pathological Society many years ago. (Fig. 5.) Among the inflammatory lesions which produce scoliosis may be mentioned cicatrices from burns, lacerated wounds, and old sinuses.

The neurotic curve is not an infrequent one, and may be either akinetic or hyperkinetic. In the former we have loss of power in the muscles, and ordinary stimulants do not have any effect. In this instance the equilibrium is not maintained, and the opposing muscles, of course, act without the necessary restraint, and a curvature results. (Fig. 6.) Polio-myelitis is the

FIG. 6.

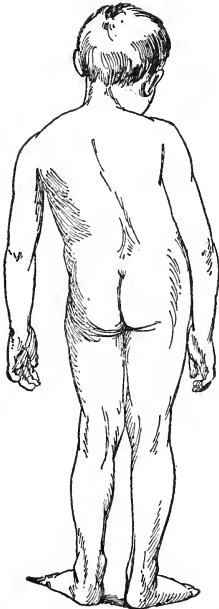

High dorsal scoliosis from infantile cerebral hemiplegia.

FIG. 7.

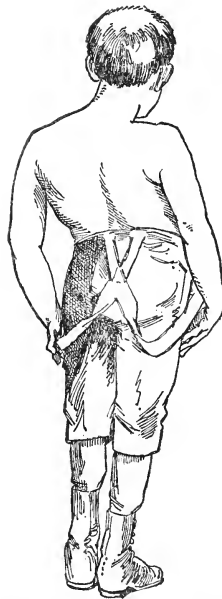

High dorsal scoliosis to the left, dependent upon paralysis resulting from polio-myelitis.

most common form of paralysis which belongs to the infantile period. The curve dependent upon paralysis is usually lumbar, for the reason that the groups most commonly affected are those having their attachments to the spinal column and one or the other of the lower limbs. Where the shoulder group of muscles are involved, the curvature is naturally dorsal or cervico-dorsal. (Figs. 7 and 8.) I have at present under observation a case of paralysis of the transversalis and oblique (external and internal) caused by



a polio-myelitis seen eighteen months ago, and the case is a lordosis confined to the lumbar region. By reason of the lack of symmetry, the paralysis of the muscles on the right side being more extensive than that of the muscles on the left, the scoliotic curve was towards the left side. (Fig 9.)

FIG. 8.



High degree of scoliosis, with cyphosis, the result of paralysis from polio-myelitis.

FIG. 9.



Lordosis with slight scoliosis in a case of paralysis of the transversalis and oblique, resulting from polio-myelitis.

The lack of muscular power is most beautifully shown when the child cries.

In enumerating the causes, both predisposing and exciting, I may have unwittingly passed over some of minor consideration; but I am sure that all of any practical value have been included.

**Pathology.**—Naturally, in going so fully into the etiology, much that pertains to the pathology will of necessity be included. The distinction between Pott's disease and lateral curvature is that in the one the osseous changes are due to an osteitis, in the other they are due to mechanical pressure. It is seldom that any inflammatory changes are found in scoliosis. The pain that is often an underlying feature is induced by pressure on nerve-roots or on other sensitive structures. We find in a confirmed case a specimen, which may be described as follows:

**General.**—A rotation or twisting of the spinal column, producing not only lateral but also antero-posterior curves, a distortion of the head and neck, a prominence of one shoulder, a flattening of the ribs on one side, with an increased curve on the other, an inequality of the thoracic cavities, a

shortening of the vertical diameter of the abdominal cavity, with overlapping of the free ribs and the *alæ* of the pelvis,—besides an alteration in shape of the thoracic and abdominal viscera.

*Special.*—An amount of transverse rotation of one body on the other, proportionate to the severity of the case and to the locality of the deformity; a wedge-shaped appearance of the bodies of the vertebrae, the base of the wedge being towards the convexity; an alteration in the transverse processes, with a like change in the articular facets,—this is best shown by a diagram I have taken from Mr. Adams. This diagram (Fig. 10) shows a slight deviation of the apices of the spinous processes, and the altered relations of the transverse processes; a posterior projection of the angle of the ribs on the concave, and a recession of this angle on the convex side; and a diminution in the height of the spinal column. Minor appearances, of course, are noted, but, pathologically speaking, the changes above noted comprise the most important features. Some recent writers maintain that an osteitis takes place, and that we have very nearly the same lesion in a lateral curvature that we have in a Pott's disease. Proof is wanting, however, for this, and for the present, at least, in children, no authorities of any note can be quoted in confirmation of this view. It is true that atrophy of bone takes place, and that contact of one transverse process with another, by reason of the twisting and the deviation, may produce a peripheral osteitis, and there may be osseous adhesions here; but these are all secondary to the original lateral curve, and cannot be considered as a pathological process in rotary curvature.

FIG. 10.

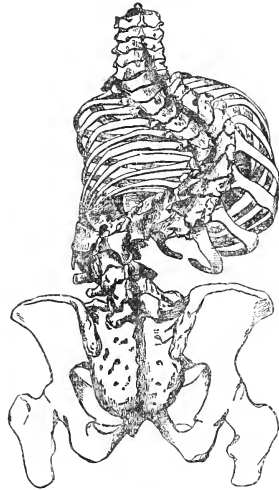

**Clinical History and Diagnosis.**—In the early years of child-life it must be understood that certain signs are present, and that these can be found on close examination. A child should be stripped quite naked, and an observation for symmetry made with the patient standing, sitting, walking, and lying down. One can readily discover any discrepancy that may exist on one or the other side of the body. This discrepancy is usually in the form of a projection of the ribs backward and outward, a slight prominence of the angle of the scapula on one or the other side, and a raising of one shoulder, the child habitually carrying one shoulder higher than the other. (Fig. 11.) These signs can be discovered, I say, quite early, and, while the mother may overlook this, it occurs to me that mothers should be taught this inspection of their children, who must continuously come under

their observation while bathing them. A further sign is some irregularity of the sternum, either a "pigeon-breast" or a "bird's nest." The costal cartilages below the ribs may be irregular. These changes in front are suggestive, to say the least, and indicate, as we know, a rachitic cachexia. One will at this period look in vain for any deviation of the spinal column to the right or to the left: this is a later sign. Comparative measurements of the two sides of the chest will reveal an inequality,—slight, but still present.

FIG. 11.

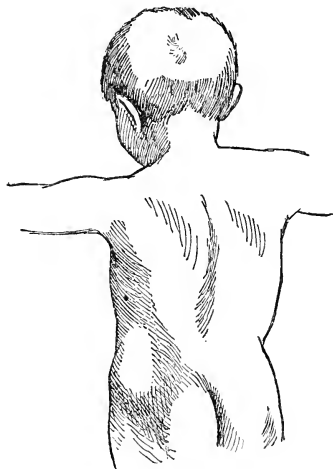

Early stage of scoliosis in a small child.

More prominent signs are found as the child is older,—in fact, as the child approaches the age of adolescence,—and I am sure I shall be pardoned for giving these signs as they may be found in early life. They are as follows.

There is an apparent obliquity of the pelvis,—a depression of the ilio-costal space on one side, with obliteration or partial obliteration of this space on the other; the free ribs approximate the crest of the ilium; the chest-walls may be apparently a little large, or may form a ridge in a vertical line, instead of presenting the rounded appearance of health; the spinal column itself has the shape

of a letter S, more or less exaggerated; the spinous processes are conspicuous in certain regions and hidden in others; the erector spinæ muscles, and other muscles intimately associated with the spinous and transverse processes, show a ridge-like prominence on the side of the convexity. The scapulae are very uneven, the one on the convex or bulging side projecting forward and backward rather, giving the name of "angel's wing," while the one on the concave side hugs the chest-walls closely, and its lower angle looks forward rather than backward, and approximates the vertical line; the muscles running from the head to the shoulder show prominence on one side, dependent altogether upon the locality of the curve; and the mammae are unequal in size, the one on the concave side being usually the smaller. (Figs. 12, 13, 14, 15, 16.)

In addition to all this, there may be much pain in the back. In females very often there is a sensitive spine, such as one finds in hysterical subjects. There may also be intercostal neuralgia. If the patient be made to bend forward, with limbs parallel and knees extended, bending chiefly at the waist, the rotation can be distinctly seen. (Fig. 17.) In slight cases a rotation can be observed in this way. At the point of distortion the spinous

FIG. 12.

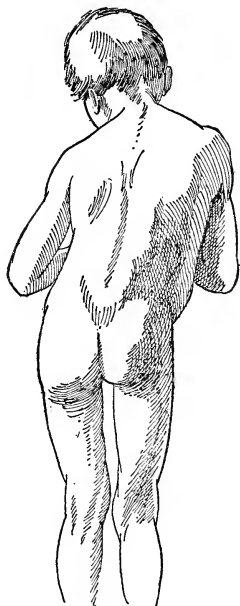

High dorsal scoliosis to the right.

FIG. 13.

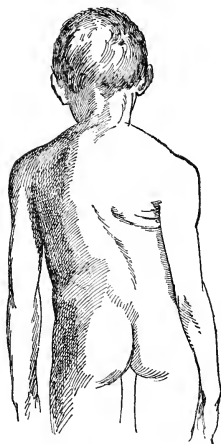

High dorsal scoliosis to the left.

FIG. 14.

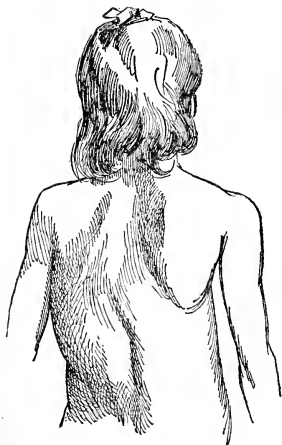

Lumbar scoliosis to the right, with compensating curve in dorsal region to the left.

FIG. 15.



The most common form of scoliosis,—dorsal to the right.

processes can with difficulty be recognized. The meaning of this is obvious. One can readily see how a twist in the bodies of the vertebræ will deflect the tips of the processes to one side, and thus render them inconspicuous.

FIG. 16.



Dorsal scoliosis to the left in a boy.

FIG. 17.



A case of right dorsal scoliosis, the patient bending forward to show the amount of rotation.

Such are the signs and symptoms observed in the case of lateral curvature of the spine. With a knowledge of these facts one can readily make a diagnosis very early in the affection; and, as the science of medicine progresses, the duty of the physician to recognize diseases early, before the stage of deformity comes on, cannot be too strongly emphasized.

**Treatment.**—In discussing the treatment of curvatures of the spine, regard must be had to the age of the patient, to the intelligence of the parents, and to the stage at which the deformity comes under surgical observation. In very young children—infants, in fact—I do not often find it necessary to apply apparatus. The mother's hands can be made to serve a useful purpose in correcting a slight amount of deformity at this period of life, and, if one instruct her how to press upon the convex side from behind forward, and upon the concave side from before backward, a pretty fair amount of rotation in the opposite direction can thus be induced. This procedure should be repeated several times during the day; and, in the second place, a position should be taught by which the child will get the weight of its head and lower extremities acting against a fulcrum of some kind at the point of greatest deformity. Thus, the mother or nurse can be taught to seesaw the child, as it were, with the hand, when holding it, and when lying down a hard pillow can be placed under its side. In other words, teach the mother the principles of treatment, tell her just what you hope to accomplish thereby, and enlist her fullest co-operation. Her sympathy and her attention you are sure to enlist. If evidences of rickets be present, treat this condition by appropriate remedies, such as cod-liver oil, sto-

machies, and phosphates. The nutrition of the child, of course, must be improved. If much deformity exists, then a very simple form of apparatus, consisting of a brace made so that pressure will come on the convex side, can be employed.

After using various forms of appliance, I am convinced that the brace known as the Knight brace, used by Dr. James Knight for many years at the Hospital for the Ruptured and Crippled, serves the best purpose. The adjustment of the appliance, of course, is all-important. It should be made of light steel, the bars should fit the body, and all unnecessary upholstery should be omitted. This apparatus is figured here (Fig. 18), and has the advantages of being light, open except where pressure is needed, and inexpensive. If one attempts, however, to fit the child to the brace, rather than the brace to the child, success will surely be wanting.

I have had no experience with the Shaffer brace in very young children, but can readily see how this could be so adjusted that the deformity would be corrected. I

regret that I am not able to present a cut of this apparatus. It consists of two bars arranged like the blades of a pair of scissors, the joint being placed just over the lumbo-sacral spine. One of the long arms carries a pad or plate which makes pressure over the ribs of the convex side, the other an axillary crutch which is held in position by a strap of webbing passing from the front of the shoulder backward to the pad just mentioned. The handles of the scissors, so to speak, are secured to the pelvis by webbing, which passes from behind around over the front, and a buckle serves to separate the handle, thus increasing the pressure over the projecting ribs.

The Barwell dressing could also be used with advantage in the lateral curvature of infants. My own experience with this dressing is confined to adolescent cases. With the aid of a dress-maker, a well-fitting appliance can be constructed, as shown in Fig. 19. The figures on the following page (Figs. 19-22) I have taken from Mr. Barwell's article on "Lateral Curvature of the Spine," published in the *Lancet* for August 13, 1887, pp. 302 and 303. The two sets of illustrations appear almost identical at first glance, but Figs. 21 and 22 have, Mr. Barwell claims, a very different action, and this bandage is to be employed when rotation is strongly marked.

However useful a plaster-of-Paris corset may be in adults or in adoles-

FIG. 18.

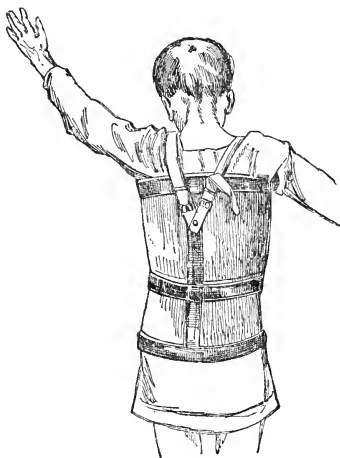

The Knight brace for lateral curvature.

FIG. 19.

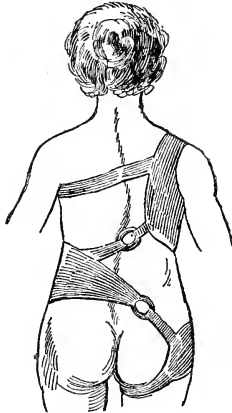

Barwell's dorso-lumbar bandage, posterior view.

FIG. 20.

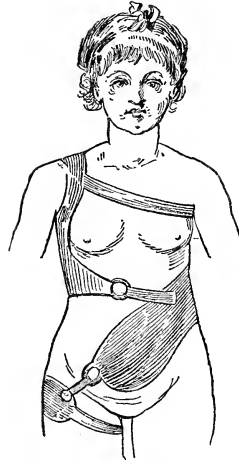

Same bandage, anterior view.

FIG. 21.

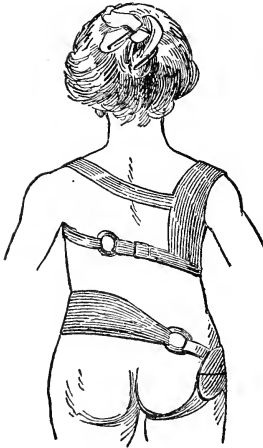

Barwell's rotation bandage, posterior view.

FIG. 22.

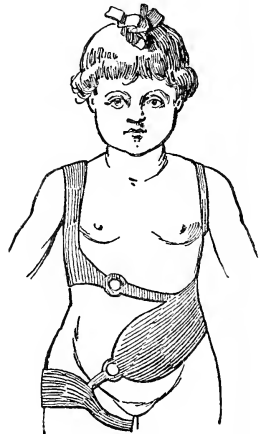

Same bandage, anterior view.

PHOTO. 3.



SHOWING THE USE OF SELF-SUSPENSION, THE PATIENT BEING IN THE SWING.

PHOTO. 4.



THE SAME PATIENT WITHOUT SELF-SUSPENSION.



i  
t  
in  
p  
us  
sic  
the  
app  
or  
and  
diff  
the  
form  
rest  
wor  
ment  
fess  
gene  
modi  
of the  
and th  
As a r  
1.  
breath  
made v  
shoulde  
ward, a  
tight et

cence, one seldom thinks of employing it in very young children. Indeed, the consensus of orthopædic opinion to-day is against the use of the corset, except in cases where gymnastic exercises are impracticable. This remark holds good with respect to all plastic appliances, such as felt, leather, raw-hide, tripolith, etc. In children under eight years of age a jacket is sometimes a necessity,—so many, I find, are hard to manage in a gymnastic class. These children require an extra amount of drilling,—individual drilling,—and home co-operation is seldom available: so that my practice is to put these cases, as a rule, in either a plaster-of-Paris corset or a steel brace, described above.

I have introduced Photos. 3 and 4 in order to show just what can be accomplished by self-suspension, and the query would naturally arise in the mind of the reader, why not employ this method of treatment? The reply is that the improved position can be retained very easily in the plaster-of-Paris corset, but as soon as the corset is removed the deformity recurs, and in an exaggerated form, because the muscles are weakened more or less by the use of the jacket; and it so happens that this special case did fail to improve, and the deformity became more marked while she was under this plan of treatment.

Much can be done by instructing the parents in the kind of chairs to use at home, or a special chair for the child can be constructed, with one side a little higher than the other, so as to force the child to sit in a position that will correct the deformity. Often an inequality in the lower limbs, not appreciable by measurement, can be corrected by raising the sole of the shoe, or even the heel. One is so prone to measure the limbs with a tape-measure, and then say there is no occasion for a high shoe, because he finds no actual difference; but the pelvis is very often tilted, and by raising the limb in the vertical axis the pelvis is placed in a horizontal plane, and the deformity is corrected. Sometimes by raising the pelvis still higher the same result is attained. All these means can be employed with great advantage.

The treatment by medical gymnastics is gaining ground, and is certainly worthy of commendation. We are indebted to Sweden for the development of this method of treatment, and no city is without a number of professors in so-called *mécano-thérapie*. For two or three years I have, in general, adopted the formulæ of Mr. Bernard Roth, of London, but have modified my exercises in accordance with what seemed to be the indications of the case. I find it necessary, as he states, to superintend this treatment, and the necessity for drilling is just as important here as in any other study. As a matter of routine I generally prescribe the following exercises.

1. *Respiratory*.—This consists in taking a deep breath, holding the breath as long as possible, and then gradually exhaling. The inhalation is made with the mouth closed, the exhalation with the mouth open. The shoulders must be thrown well back, the palms of the hands looking forward, and the body as nearly erect as possible. It is needless to say that all tight clothing about the neck must be removed. From three to five deep

breaths in succession are taken, the patient standing. This exercise is repeated with the arms extended above the head, shoulders thrown back, palms forward, the same number of times.

2. *Head Rotation*.—With the shoulders thrown well back, arms by the side, and palms looking forward, the patient rotates the head from side to side to the fullest extent, and at the same time employs as much force in the act as possible. Twenty times for this movement.

3. *Lateral Flexion of Head*.—Same position as in above, with head flexed from side to side without raising the shoulders. Twenty times for this movement.

4. *Circumduction of Arms*.—As complete circumduction as possible, shoulders well thrown back, forearms extended. From ten to twenty times.

5. *Leg and Thigh Circumduction*.—This is a circumduction of the right lower limb, leg fully extended, motion at the hip, the patient lying prone on a hard table, pelvis near the end. Five or six rotations each way, right and left. Then have the patient lie on the back and execute the same movement five or six times each way.

6. "*Pugilistic*."—This is a name I have given the exercise which is described as follows. The patient stands erect, shoulders well thrown back, forearms extended on arms and the whole limb extended forward at a right angle with the body, palm of hand looking upward; clinch fist, flex forearm vigorously on arm, which falls to the side of the body, extend again in first position, flex again as before, extend arm from the side with forearm fully extended, bring arm and forearm down to the side of the body, palm still looking forward. Let the patient count five for this movement, and execute the whole exercise from seven to ten times.

7. *Thigh Hyperextension*.—The patient, lying prone on a table, hyperextends the thigh, with leg fully extended, brings it down to the table again, up, and so on until this is done ten times. In order to hyperextend the thigh slowly and thus get a better action of the erector spinæ muscles, it is well to have the patient count five slowly while hyperextending, and five while bringing the limb down to the table. After a few days a sand-bag weighing from three to five pounds may be thrown over the leg near the ankle.

8. *The Key-Note Exercise*.—This consists in extending the forearm and arm of the concave side well above the head, while the other arm and forearm are extended from the side in abduction at a right angle with the body. Then let the patient proceed to rotate the arm extended above the head, from the shoulder, counting one while a complete revolution is made. This can be done ten times.

9. *Trunk Resisting*.—This is as follows. The patient stands at the end of a table or against a bar the height of which corresponds to the distance from the pelvis to the floor. The shoulders are thrown well back. The surgeon then, with his hand pressing against the convex portion of the chest posteriorly, and pressing against the back of the patient's heels to prevent slipping, pushes the patient forward over the table or bar, while the patient

offers resistance and counts five. Then the patient attempts to bring himself to an erect position, with the surgeon's hand resisting. This is done five or six times.

10. *The Diving Movement*.—The patient lies prone on a table, with the whole body extending over the end, while the surgeon or attendant grasps the legs in order to hold the patient on the table. Then, with the forearms folded over the back, the patient bends slowly down towards the floor, counting five during the act, then brings the body up to a line with the table, and so on, going through this movement from five to eight times, according to circumstances.

11. *Head Resistance*.—The patient stands erect, with the arms and forearms extended from the body towards the front, pressing the hands against the wall, while the surgeon with his hand pressing against the back of the head attempts passively to flex the head on the chest, the patient resisting and counting five. Then the patient brings the head up in extension while the surgeon's hand resists, counting five at the same time. This exercise can be repeated half a dozen times.

12. *The Four Count*.—Body erect, hands grasping dumb-bells, chest forward, hips back, shoulders well thrown back, chin drawn in. First, bring the arms up and forward from the side of the body to a right angle with the body; second, throw the arms outward, still at a right angle with the body; third, bring the arms downward and backward to strike the little-finger ends of the bells; fourth, a second strike.

13. *Anvil Chorus*.—Same position as in the above, with dumb-bells, arms in position of No. 4 as above. Strike alternately thumb ends and little-finger ends of dumb-bells, counting one for each.

14. *Wand Movement*.—Position, arms by the side of the body, grasping the wand with each hand. First, throw the arms above the head, taking care to have the wand parallel with the horizontal plane of the body; second, with the pelvis and limbs fixed, by voluntary effort rotate the trunk on the pelvis to the side opposite the convexity; third, back to second position; fourth, down to the side of the body. This movement is especially good for the rotation.

15. *Deltoid Movement*.—With dumb-bells in the hands, raise the forearms from the side of the body to the highest possible extent; then down, counting one, two.

I am indebted to Dr. B. E. McKenzie, of Toronto, for these last four exercises.

The above list comprises all that are really necessary, and as the patient gains in strength dumb-bells may be employed in most of the arm movements. I am convinced that light dumb-bells are much better than heavier ones, and the latter should not be allowed. I am using now half-pound and one-pound wooden bells. It is quite possible that the surgeon may see other exercises that will apply better to individual cases, and may find self-suspension necessary if the curve is high. At least one hour should

questioning elicits, as a rule, a very vague etiological description of the traumatism. Thus it often happens that in a child presenting a marked deformity the traumatism assigned as its cause is referred to a very recent period and is in character entirely out of proportion to the supposed result. There can be no doubt that, in the majority of cases presenting clinically, the relations of cause and effect, considered from the stand-point of injury, are such as in no wise to account for the symptoms presented. If it should be accepted that the most frequent causes of Pott's disease are concussions and blows, as urged by the traumatists, it would follow that many thousands of children in daily receipt of such injuries would be the victims of this disease or of some analogous joint-trouble. That this is not the fact is proved by the comparative infrequency of the disease in question. Again, the amount and character of injury are important considerations. Thus, in many children a very slight traumatism has been given as the cause of the subsequent trouble, and in many cases, if no other conditions were present, might be accepted as a definite cause. Against these may be placed the severe injuries and falls received in childhood, terminating in a short time in perfect recovery or in death. From this it follows that in the one case there must be some special or underlying condition predisposing to the production of a chronic insidious disease, while in the other case the healthy organism so modifies the process that a different result is brought about.

The fact of the matter, as it appears to me, is that injury, considered purely as a primary determining cause, has no claims to special consideration in the large majority of cases; that Pott's disease often develops without any history of such injury as would show a conclusive connection between the injury and the disease; and that at best it is but the exciting cause bringing into activity an underlying general condition, and manifested by its local expression at the site of the supposed traumatism.

Among the causes of caries of the spine which stand in the relation of direct exciting agents, the continued fevers of childhood, measles, scarlatina, etc., and in fact all depressing conditions lowering the vitality, are prominent and direct etiological factors. The same underlying condition described as giving potency to injury is undoubtedly often present, the difference in the traumatism being simply one of character and degree. The influence of a depressing poison on a tender developing bone is none the less on account of this difference in causation, although manifest often in a different manner.

**Diathetic Causes.**—Our knowledge of scrofula and tubercle in their causal relations to Pott's disease is as yet not of that definite character which is desirable, and therefore cannot receive more than a passing notice. When we speak of scrofula reference is had rather to a state or vulnerable condition of the tissues than to a complete pathological entity. Scrofula, therefore, we would refer to as a condition of the system rendering it peculiarly prone to chronic inflammations of a low type, retrogressive in character, and often occurring without adequate cause, accompanied by

certain marked tendencies to skin-affections, glandular enlargements, and bone-disease.

Tubercle at the present day plays so important a rôle in its etiological relation to bone-inflammations of the chronic type, and is of such consequence, that a detailed discussion would hardly be in place here. For a complete description the reader is referred to the article on tuberculosis, in another section of this work.

Syphilis and rheumatism may at times be diathetic conditions productive of Pott's disease, but as yet no direct evidences have been collected concerning these conditions and their manifestations in the malady under discussion.

#### PATHOLOGY.

Pathologically it may be well here to regard the lesions found in Pott's disease as identical with the changes found in other bone-structures in which there is tubercular caries. This is destructive in character, and may be confined to a single vertebra or may involve several. (Fig. 1.)

It is in many cases attended or limited by the occurrence of a rarefying osteitis. In the strumous form of rarefying osteitis the first step in the process of inflammation is that of congestion, the bone appearing as if blood were extravasated throughout its structure; secondly there is the formation of granulation-tissue; and lastly there occurs a degeneration and softening of the new formations, with purulent exudations and absorption of bone-trabeculae. Now the bone-corpuscles undergo fatty degeneration, and are presently destroyed, and, owing to strangulation of the vessels, caseation of the inflammatory products results. When the disease is rapid, the cancellous spaces and Haversian canals are filled with pus. The process, being a strumous or tubercular one, differs from simple traumatic rarefying osteitis, arising, as it does, from an internal or constitutional cause, or from such local irritation that a slight injury would bring it into activity. Even such injury is not necessary to provoke this strumous or tubercular caries, it often arising from no appreciable cause. A peculiar feature of this caries is its limitation to spongy bone-tissue, it rarely affecting the transverse, articular, or spinous processes primarily. (Fig. 2.)

Again, this degenerative process assumes different degrees of intensity, being in some cases superficial, involving only a portion of the anterior surfaces of the vertebrae, while in other cases it not only excavates the body of the vertebrae, but also attacks the intervertebral fibro-cartilages and the adjacent soft parts, giving rise to abscess. (Fig. 3.) Not infrequently the



FIG. 1.  
Showing extensive erosion of dorso-lumbar vertebrae.

abscess is confined within the bone, the exudation becoming purulent, the granulation-tissue breaking down, the pus and débris collecting into an

FIG. 2.

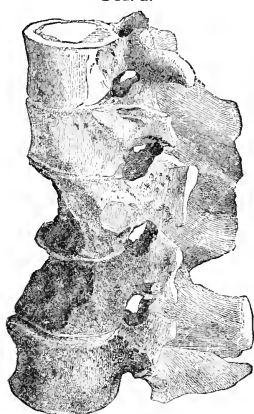

Erosion of lumbar spine, psoas abscess, without deformity.

FIG. 3.

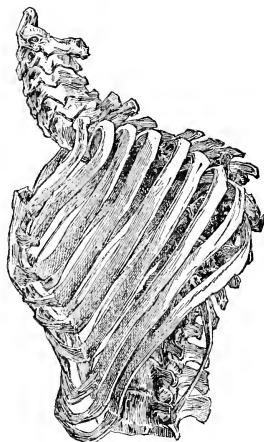

Characteristic "hunchback" deformity.

abscess-cavity, and the walls of the abscess being composed of the inflamed disintegrating bone and lined by caseous pus.

FIG. 4.

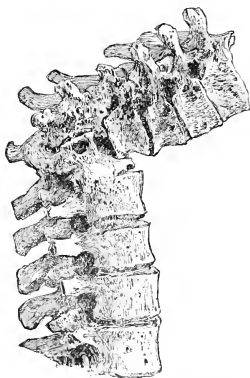

Marked angular curvature, resulting in compression, myelitis, and paraplegia.

It oftener happens that in rarefying osteitis the bone is absorbed in such a manner that an island of osseous substance is separated from the rest by a belt of granulation-tissue and dies, giving rise to the *caries necrotica*, but if it retains its vascular connection it forms a living sequestrum. While the bodies of the vertebrae are being absorbed, osteoplastic or protective osteitis takes place about the neural arches, being a conservative action, preventing by sudden dislocation a crushing of the spinal cord. (Fig. 4.)

A class of cases were first described by Brodie in which no suppuration took place, and these have at a more recent period been designated as dry caries, or *caries sicca*. They are identical with the so-called "osteitis fungosa" (Billroth), and are characterized by the presence of interstitial granulation-tissue growing throughout the bone. Here the granulation-tissue fills the Haversian canals and medullary spaces, and insidiously eats its way into the bony

meshes. In this class of cases the granulation-tissue may undergo fatty degeneration and caseation without suppuration.

It will be readily seen that the foregoing condition differs widely from the simple rarefying osteitis, or caries, the result of injury, there being in the latter no underlying vice of the system. In this class of cases we have first a simple dilatation of the blood-vessels, followed by a pouring out of liquor sanguinis and leucocytes. In many cases the process stops at this point, and, the inflammation subsiding, resolution takes place, the parts returning to their normal contour. This limited caries undoubtedly explains the rapid recovery of many cases of so-called spondylitis following traumatism, and may also happen when Pott's disease follows one of the exanthemata, the patient being of sound constitution at the time.

#### SYMPTOMATOLOGY.

Before attempting to enter into a complete description of the symptoms as met with in the different regions of the spine in a case of Pott's disease, some general consideration of the different stages is of importance, and of these we will begin with the stage of invasion.

In the vast majority of cases the general health of the patient has been for a greater or lesser time below the normal standard. Even without any tubercular or strumous history or appearance that is marked, there is a condition present best expressed by the comprehensive term *malaise*. A child shows indifference to its surroundings, its usual occupations or enjoyments, and presents a listless, dejected appearance. It is easily tired and irritable, and appears sick. The appetite, previously good, becomes affected; the child loses flesh, and the skin assumes an appearance very different from the clear look of perfect health. The muscular tissues often become flabby, and the total appearance of the patient indicates that it is affected by some insidious potent malady.

Here we have the condition met with in many bone-diseases, especially where the epiphyses are principally affected, the so-called "incipient stage," or, as it has been otherwise designated, the "pre-tubercular" or "vulnerable" condition. This stage often escapes detection, the symptoms rarely being connected with the disease, and their importance being frequently overlooked. These symptoms indicate the existence of a period, and their correct interpretation at this time is of the utmost importance as regards the ultimate result of the case, this being the most favorable time to avert an increase of inflammation and prevent deformity.

**Stage of Pain.**—Succeeding the rather general disturbance just described, we come to a period the most important symptom of which is pain. The pain of Pott's disease varies greatly in character and extent, and its location is always dependent on the site of the inflammation.

It will be well in this connection to say a few words regarding the commonly-accepted idea that the pain of caries of the spine is always to be found posteriorly localized at the seat of the disease as manifested by the de-



formity. Much importance in making an examination of the spine has been attached to the recognition of this *local* pain, by means of hot sponges and other substances passed along the spinal column. Nothing could be more fallacious, experience showing that the pain of Pott's disease is referred to the posterior portion of the spine only in very rare instances.

The pain of Pott's disease is, as a rule, subacute, varying greatly in character and in degree, in many cases being intermittent, at other times being described as lancinating and intense. There is a marked relation between the rapidity and extent of the inflammation and the amount of pain. Its location may be tersely stated as following the general law that pain which is the result of nerve-irritation is reflected to its periphery. Thus, it is often found below the seat of the disease and anteriorly (*gastralgia*), but rarely above it, the exception occurring in some cases of cervical caries. As a rule, the pain is worse in the earlier stages and at night, and is aggravated by motion and position. Cases have been recorded, however, where pain has been entirely absent through the whole course of the disease.

**Stage of Muscular Rigidity.**—We next meet with a condition of the muscles which is of importance in both diagnosis and prognosis. This is a state of spasm or rigidity, and is supposed to be due to reflex irritation of the nerves supplying the diseased bone. Its presence is regarded as pathognomonic of osteitis. Here, as in all the large articulations, where the condition of the muscles is constantly found associated with joint-disease, its function would seem to be an attempt to mobilize the part, and is nature's effort to bring about this end. It is an early sign, sometimes appearing even before pain is complained of, and continues to a very late stage of the disease. This constitutes at times the only available symptom, and is at all times of the greatest practical importance in diagnosis when properly interpreted. It is not to be confounded with the bony rigidity found at a late period of the malady, the result of partial or complete ankylosis. This reflex muscular spasm is unique in character, and its study in connection with chronic bone-disease shows peculiarities not found in other conditions. It is an unyielding tetanoid spasm, present day and night, being, so to speak, forever on guard to prevent any injury to the diseased part. It yields only to complete anaesthesia, ordinary doses of opium or chloral not affecting it. Accompanying this spastic condition of the muscles, the result of nerve-irritation, we also have a specific atrophy, reflex in character, and noticeable at times in Pott's disease where the muscles are well developed, especially in the erector spinae group, and progressing in direct ratio as the disease advances. This symptom is not always so easy to determine in Pott's disease as in other articulations, located more specifically, but is undoubtedly always present.

**Stage of Deformity.**—Although, rationally considered, the deformity of spondylitis takes place at a later period than the stages already mentioned, it is by no means unusual, especially in public practice, for it to be the first symptom of sufficient importance to attract the attention of the parents

or friends to the patient, or deemed worthy of the care of the surgeon. This projection backward of one or more spinous processes is identical with that period already mentioned when speaking of pathology, where there is a breaking down of the vertebral bodies forming the anterior support of the spine. The superincumbent weight falling on the weakened support increases the projection, causes abnormal pressure on the carious and weakened vertebræ in their changed direction, and alters the normal curves of the spinal column. Where the carious process is rapid and extensive, the amount of deformity will be proportionately large, and sharp or gradual according to the amount of disease present. Where the long gradual curve is present, it shows a large area of inflammation, but not necessarily a rapid one. On the contrary, where only one or two vertebræ are involved in the carious process, the deformity is sharper and well defined. In the cervical and lumbar regions determination of the amount of disease by the appearance of the deformity is entirely unreliable, the deformity in these situations, owing to the anatomical position and construction of the vertebræ, rarely attaining the proportions found especially in the mid-dorsal spine. By some authors it is held that the shape of the curvature establishes the suppurative or non-suppurative character of the lesion. Thus, it has been maintained that *caries sicca* frequently involves a number of the vertebræ primarily, the resulting projection partaking more of the character of a true curvature, while but few vertebræ or only a single one are involved in the acute suppurative variety, giving rise to the sharp, angular deformity.

**Stage of Abscess.**—Among the most common of the consequences of caries of the spine is the formation of abscesses, which during their formation and course give rise to important symptoms. While these, as a rule, are more frequently met with in the later periods of the disease, the patient is at no time exempt from them, and they may occur at the earliest time, even before deformity is visible. Again, some cases run their entire course without the appearance of an abscess, while in other cases abscesses have been detected, which have disappeared without opening or giving rise to any marked disturbance. These collections of pus, coming from the carious foci, follow the general rule of the least resistance, and in their passage important parts and organs are protected by the fasciæ. It may be stated that they open at some distance from the point of origin, and according to the site of the lesion. The most common situation for the formation of these abscesses may be broadly stated to be found in connection with caries of the dorso-lumbar region. The dorsal abscesses find their way beneath the ligamentum arcuatum into the sheath of the psoas muscle, and are guided by the attachment of the sheath of this muscle under Poupart's ligament and into Scarpa's triangle, where they most commonly open and discharge their contents. Caries of the lower lumbar spine gives rise to the so-called lumbar or gluteal abscess. This has its normal outlet through the great sacro-sciatic notch, and most often points at the lower border of the gluteus maximus. Sometimes these lumbar abscesses appear posteriorly,

having perforated the quadriceps lumborum, and make their appearance at or about the seat of disease. In caries of the upper or cervico-dorsal vertebra abscesses pass in front of or behind the sterno-mastoid, or into the posterior wall of the pharynx, where they are known as retro-pharyngeal abscesses. Again, they may be found in the thorax, forming a mediastinal abscess, and discharge into the trachea, bronchi, or œsophagus, or at some external point.

While we have, for the convenience of the reader, given the usual course pursued by these spinal abscesses, it is not to be understood that they all follow these methodical directions. Indeed, their course is subject to the greatest vagaries. Thus, we have records of cases where the abscesses opened at various abnormal positions,—in the mouth, lungs, bronchi, stomach, intestines, bladder, and rectum, or in external parts remote from the site of formation. A remarkable circumstance in connection with the course of abscesses connected with spinal caries is the very rare occurrence of a fatal termination directly traceable to them. We have, however, already spoken of the protection afforded to important adjacent parts and organs by the fasciæ along which the abscess passes.

As a rule, not much disturbance of a general nature is experienced during the development and course of an abscess. The patient may have an exacerbation of evening temperature, with slight chilliness and perspiration. Pain is slightly increased, the latter ceasing, however, as the pus reaches an external situation, or where inflammation does not occur in the sac itself. The abscess may, however, occasion much local disturbance, according to its location and size. In retro-pharyngeal abscess dysphagia and suffocative attacks may be experienced, and when it opens into the bronchi there is an expectoration of pus, attended by extreme dyspnoea and collapse. All the reported cases of rupture into the peritoneum and large blood-vessels have terminated fatally. Abscesses may remain stationary for a long time, and, especially in children, give rise to very little disturbance of function or of the general health. Occasionally they are, under careful mechanical treatment, absorbed; but, as a rule, they steadily increase in size and finally rupture.

**Stage of Paraplegia.**—It so often happens in disease of the lower cervical and upper dorsal region that we meet with paraplegia of the lower extremities that, while it cannot perhaps be considered as strictly a distinct stage of Pott's disease, it is still of sufficient importance to demand separate description. This paraplegia, which generally involves only the motor functions of the cord, has been usually believed to be the result of a compression-myelitis, and, while pathologically partaking rather of the characteristics of a pachymeningitis or meningo-myelitis, gives rise to such symptoms as would ordinarily result from a myelitis due to pressure, either from inflammatory products or abscess. Its onset is marked by a gradual diminution in the strength of the parts affected, until eventually there is complete loss of power, but usually little disturbance of sensation. All the reflexes

are increased, as indeed they are very early, and at times it is possible to prognosticate the approach of the paraplegic condition by this exaggeration of the patellar tendon and other reflexes. Muscles which are the seat of paraplegia become rigid and tense, and at times marked clonus is easily produced, while at a later period, where the paraplegia has existed a long time, permanent contracture may result. The paraplegia of Pott's disease is a bilateral affection, and, as before stated, usually involves the lower extremities. In rare cases of dorsal caries, more frequently of upper cervical, the upper extremities may be involved. The functions of the rectum and bladder are rarely disturbed, and there is little interference with the general nutrition of the patient, atrophy taking place only in the paraplegic parts. Indeed, it not infrequently happens that many of these patients gain flesh, probably from their forced confinement in one position. Recovery is often spontaneous, and seems to be the natural tendency of this form of paraplegia. Recurring attacks are not of unusual frequency, a case having been under my personal observation where two attacks took place with recovery, and other writers report similar results. Cases have also been reported where recovery took place with marked sensory disturbance, as in a case under the author's care, where both sensation and motion were lost. As a rule, the involvement of the sensory function would render the prognosis less favorable than where there was simple motor paraplegia.

#### DIAGNOSIS.

It may be stated as a general axiom that diagnosis is of value proportionately as it enables us to give early and prompt treatment to the patient, and in no disease is this more pertinent than in the one under consideration. No difficulty in diagnosis is experienced where, as is, unfortunately, too often the case, patients present a kyphosis and abscess well marked, or a paraplegia in full progress. Here, however, the opportunity for relief, certainly so far as deformity is concerned, is reduced to the minimum. Where we are brought into contact with a case in which we do not find this tell-tale deformity or other marked symptom,—in other words, an incipient case,—the question of diagnosis becomes a more difficult one, and will necessitate a most careful inquiry into the symptoms, both subjective and objective, before we are enabled to arrive at a proper conclusion.

Examination of a patient presenting with symptoms which would indicate the existence of spinal caries should be conducted in the following manner. A history should be taken, according to a uniform plan, and with especial reference to certain points. The general condition, hereditary tendencies to diseases, apparent cause, and mode of invasion should first occupy our attention. Secondly, the subjective symptoms—pain, etc.—should be considered. Thirdly, the attitude and aspect will often give valuable help in diagnosis.

Most important is the physical examination of the patient, and this should be conducted as follows. The patient, after being stripped, is placed

w  
H  
di  
w  
te  
st  
we  
tir  
bo  
of  
to  
ter  
jet  
mo  
sym  
eas  
reg  
upp  
ere  
par  
bei  
the  
ma  
fing  
Def  
pec  
rota  
ble  
been  
tion  
axis  
phat  
reer

borne, and we are often enabled to observe a marked broadening of the neck. In the attempt to hold the head in such a position that concussion from jar is least liable to be felt, the spinal column below the point of disease assumes a compensatory curve, giving a hollow appearance to the dorsal part between the shoulders, with a projection in the lumbar region.

In cervical disease it is sometimes possible to feel the thickened vertebræ through the mouth, especially where the caries has advanced sufficiently to occasion some breaking down of the bodies and bulging forward of the post-pharyngeal wall, or, again, where an abscess points in this region. Paraplegia may be associated with disease of this part.

Less frequently than disease of the third, fourth, and fifth, we meet with disease of the first and second cervical vertebræ, or atlo-axoid disease. Here rigidity is quite expressive, and of itself furnishes a diagnosis. In disease between the atlas and axis all rotary movements are checked, and, while it is very rare that we have uncomplicated disease of these two vertebræ, a sufficient number of cases occur to make this limitation of motion strongly characteristic. It is in this region, although not exclusively, that we meet with the torticollis dependent on spinal caries, and this is sometimes difficult to distinguish from wry-neck due to causes independent of bone-disease, but is always a valuable aid to diagnosis. The characteristic of this symptomatic torticollis is that in spinal caries the head is rotated towards the contracted muscle, whereas in the idiopathic form of wry-neck torsion takes place away from it. Again, there is a spasmodic feeling imparted to the muscles on movement, and the posterior group are more commonly involved than the sterno-mastoid in the contraction due to reflex spasm. Ether abolishes the contraction completely. With atlo-axoid disease pain is found early in the upper part of the neck and in the occipital region, or, again, is complained of in the ears, the sides of the neck, or the upper part of the chest, and is neuralgic in character. This pain is increased by pressure on the head or by any movements affecting the upper part of the spinal column. Hilton speaks of pain in atlo-axoid disease as being always unilateral, and seems to think that this indicates the side of the vertebræ affected. Swelling and broadening of the neck also occur; marked protrusion of the pharyngeal wall can sometimes be felt with the finger in the mouth, the patient being subject to attacks of dysphagia. Deformity appears at a variable period, the patient having adopted a peculiar attitude. The head may be flexed or extended markedly, with rotation, but usually it is projected forward, and supported in every possible position by the patient, recumbency being the favorite posture. It has been supposed that deformity in this region depends upon a forward luxation of the atlas upon the vertebræ beneath, and the spinous process of the axis can often be felt or seen.

Abscesses are common in this region, and present frequently as "post-pharyngeal" collections of pus, giving rise to serious symptoms, which have received detailed description in works on surgery. Abscesses may appear

also at the sides of the neck posteriorly, and follow the course of other deep-seated cervical abscesses. Nerve-symptoms are very often associated with atlo-axoid disease, varying greatly in extent, from paralysis of one arm to a more general paralysis of the parts below the neck. This is usually of the motor type, but at times anæsthesia is noticed, with loss of vesical and rectal control. Cerebral symptoms meningeal in character often occur, or sudden death may take place from crushing of the spinal cord.

**Differential Diagnosis (Cervical Region).**—We have already spoken of torticollis as being at times a symptom of caries of the cervical region easily mistaken for idiopathic wry-neck, and have given a rule for its differentiation. Among other diseases liable to be mistaken for this serious malady are lateral curvature involving the upper part of the spine, muscular rheumatism, simple abscess, adenitis, acute traumatic lesions, and hysterical simulation of Pott's disease. Lateral curvature is rare in this region, and is usually accompanied by rotation and marked by absence of pain and reflex spasm. It should be borne in mind, however, that a lateral deviation of the spine may take place early in Pott's disease, and in any region, but this disappears, as a rule, rapidly with the advent of bony deformity and other pronounced symptoms, and is entirely modified by treatment. Muscular rheumatism is marked by tenderness of the muscles themselves and by the entire absence of bone-deformity, and is more apt to take place at a later period of life. The movements of the neck, while stiff and painful, give no characteristic spastic sensation, and the transitory and shifting character of the affection should leave no doubt as to its nature. Simple abscesses are usually acute in character, attended by high temperature, and their history and superficial character leave little room for doubt. Acute traumatic lesions—dislocation and fracture—are diagnosed by the history, the sudden deformity, and the usual signs of such injuries as met with in other parts of the body.

Hysterical simulation is at times exceedingly difficult to diagnose from true spondylitis, and may be encountered in all parts of the spinal column. In the simulated condition pain is the most prominent symptom, and is always complained of at the supposed seat of the disease, differing from that of true caries, which is generally reflected to the anterior part of the body. It has all the characteristics of an intense hyperæsthesia, and light pressure apparently gives rise to great suffering, such as is found in the so-called "spinal irritation." When attention is diverted, the pain on pressure either disappears or a new locality is complained of. There is no reflex spasm, voluntary efforts being made to keep the spine quiet, and *persistent gentle force* usually overcomes the resistance to motion. Care must be taken in estimating the amount of motion present, our diagnosis depending largely on the muscular expression accompanying the disease. Whatever bulging of the vertebræ occurs is immediately reduced by placing the patient in the prone position. Paralysis of hysterical origin is very common,

and at times is difficult to distinguish from the paraplegia of Pott's disease. It is, as a rule, sudden, differing from the gradual loss of power found in the course of a spondylitis, is more often unilateral or confined to one extremity, and frequently disappears as suddenly as it came.

**DORSAL CARIES.**—The attitude of a patient suffering with caries of the upper dorsal region suggests the attempt of one endeavoring to balance the head on the shoulders. (Fig. 5.) The chin is elevated, the spinal column below the seat of disease is straightened, and at times curved forward and held rigidly, and the gait and carriage of the patient are those of extreme apprehension. When the bony deformity is large, the head sinks between the elevated shoulders, giving a characteristic "turtle-head" appearance. Pain in disease of this region is referred to the chest and sides, and often there is disturbance of the respiratory function, as manifested by a peculiar "grunting," at times accompanied by cough, dyspnoea, and partial cyanosis. Interference of motion at this portion is detected with some difficulty, owing to the fact that normally here is the most rigid and unyielding portion of the spinal column. This, however, is sufficiently well marked and appreciated, especially when the other symptoms present are taken into consideration.

Paraplegia is most often found in connection with disease of the upper dorsal spine, and affects chiefly the lower extremities. Reference to this has already been made, under the head of Symptomatology.

Mid-dorsal disease gives rise to the typical "hunchback," the most persistent deformity taking place in this region. The progressive character of the lesion is due to several reasons. It is in this locality, especially the superior dorsal, that we contend with the constant traumatism of respiration, and, having a fixed projection in the middle of a flexible column, the application of proper supports becomes a matter of great difficulty. The attitude assumed by patients with disease in this region is an exaggeration of the one described under disease of the upper dorsal spine. A marked rigidity in stooping or lifting articles from the floor is noticed. The patient in performing these movements lowers the body as a whole, bending his knees and hips, and gradually approaches the article he wishes to raise, resuming the upright position with infinite care, never allowing the spine to

FIG. 5.

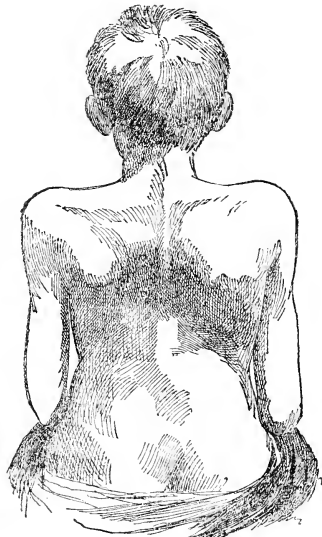

Dorsal caries.



bend. Pain is marked, especially on motion, and is referred most frequently to the lower part of the thorax and stomach, giving the "initial gastralgia" so often complained of, and at times coming on very early in the course of the disease, antedating even the appearance of the deformity. It is of great importance to realize distinctly the connection of this pain with spinal caries, as many children are treated during long periods for many different diseases, — indigestion, worms, and other disorders of the digestive tract being not infrequently assumed as the cause of the pain. The pain is frequently accompanied by the so-called "osteitic cry," and occurs most often at night, this cry being in character very much like that of acute hydrocephalus, and found in connection with disease of the bone in any part of the spine or of the articulations.

Disease of the lower dorsal spine is so intimately associated with lumbar caries that it will be best considered in the description of that region.

**Differential Diagnosis (Dorsal Region).**—Before the appearance of deformity causing abnormal curves to appear in the spine, aneurism of the

thoracic and abdominal aorta, eroding the vertebral bodies, as evinced in two autopsies the author had opportunities of making, may give rise to symptoms similar to those of spinal caries. Diagnosis by auscultation and the presence of other symptoms usually establish the nature of this lesion before the spine is much affected and the extensive curve and localized pain are sufficient to demonstrate the existence of aneurism.

Malignant growths, cancer, etc., are rarely seen in children.

Chronic pleurisy, with effusion or empyema, and other inflammatory lung-troubles, would be excluded by physical signs.



Functional spinal debility simulating caries.

Rachitic curves are very common in the dorsal region (Fig. 6), but are marked by their gradual character and extent, and are attended by the characteristic large head, flattened epiphyses, general tenderness, and inability to walk. Motion is rarely limited, the curvature mostly disappearing in the prone position. Pain, when present, is local in character, and the general listless appearance of the patient serves to explain the functional curve.

**DISEASE OF THE LUMBAR REGION.**—Disease of the lower segment of the vertebral column, which will here include the lower dorsal and lumbar

vertebræ, presents some especially important features from the stand-point of diagnosis. It is here that we have to deal with a portion of the spine largely controlled by the psoas muscles, and the reflex limitation of motion at this point gives us most valuable indications concerning not only the condition of the vertebræ, but also the presence and progress of abscess, which is more often encountered here than in disease of any other part of the spine.

Here, again, a special attitude is assumed by the patient, in most cases consisting of a "lordosis," or an anterior curvature of the spine. This is nature's mode of protecting the diseased parts, there being a conservative attempt made to throw the weight of the body from the diseased vertebral bodies on to the articulating facets. The reflex muscular spasm is best appreciated here by placing the patient in the prone position and making the movement already described in the general remarks on diagnosis. (See Fig. 7.) As stated, the condition of the psoas muscle furnishes us with excellent indications as to the presence or absence of abscess in its sheath. If, the patient being prone, the surgeon makes pressure on the pelvis with one hand, holding it firmly in one position, and, grasping the thigh with the other hand, the knee having previously been flexed, attempts to extend the thigh on the pelvis, should contraction of the psoas exist he will be met by a decided limitation in the extension of the thigh.

The application of this test, one of the utmost importance, is easily learned, and, in conjunction with palpation of the pelvic fossæ and with the general symptoms of pain, temperature, etc., will usually show the presence or absence of an abscess. This limited extension is generally found unilaterally, but may be bilateral, and on the emergence of the abscess from the pelvic cavity usually disappears. Pain from caries of the dorso-lumbar spine is referred to the hypogastric region and the lower extremities.

Paraplegia with this form of spondylitis is among the rarest of complications, for well-known anatomical reasons. Deformity, as in the cervical region, rarely reaches the degree met with in the mid-dorsal spine, and in many cases where the disease is confined exclusively to the lumbar vertebræ little or no deformity is noticeable.

**Differential Diagnosis (Lumbar Region).**—Many diseases may occur at or about this part of the vertebral column with spinal caries, and the

FIG. 7.



Lumbar caries.

knowledge and experience of the surgeon will often be severely tested in differentiating between them. Disease of the last lumbar vertebra is often mistaken for hip-joint disease, the converse being also true.

Sacro-iliac disease, perityphlitis and nephritis, sciatica, lumbago, and other diseases may also obscure the diagnosis; but space forbids a detailed account of the symptoms and methods used for differential diagnosis, the reader being referred to the articles on these subjects in other portions of this work.

#### GENERAL PROGNOSIS.

In general terms it may be stated that the prognosis of Pott's disease depends largely on that portion of the spinal column affected by the caries. Thus, the best results of treatment are usually obtained in the cervical and lumbar regions, at times lasting many years, although so-called acute cases have been reported. Much of the success achieved in later times in the treatment of spondylitis may be ascribed to a more correct interpretation of the symptoms, to a better knowledge of the etiology and of the mechanics of the parts, and, above all, to a better adaptation of the various supports used in the treatment of the diseased areas. Prognosis will always be affected by the amount of personal attention given by the surgeon, by the home care of the patient, and by the detail with which the mechanical treatment is carried out. During the progress of a case the symptoms may be held in abeyance for a long time, and the inexperienced surgeon, judging from the cessation of pain, the apparent arrest of deformity, and the non-appearance of abscess, may remove the apparatus, thinking his patient cured. Very soon, however, he is undeceived; the symptoms become more acute in character and assume an alarming aspect, the patient having one of the exacerbations known to every one familiar with these cases. The earlier the diagnosis is made and the child placed under mechanical treatment and good hygienic conditions, the better the prognosis. Notwithstanding the fact that the strumous or tubercular diathesis usually underlies the lesion, many patients recover, with more or less deformity, and sometimes live to advanced age. The deformity when once present rarely disappears, although it may be diminished at times by treatment.

Abscess was formerly regarded as a symptom of the utmost gravity as affecting prognosis, but many patients recover, with strong though sharply-deformed backs, who have had one or more abscesses. It is an undoubted fact that many abscesses form and entirely disappear, protective treatment modifying their course to a very large extent. Abscesses which suppurate and discharge by fistulous openings for a long time are necessarily of grave import in making a prognosis, owing to the ultimate involvement of internal organs, amyloid degenerations oftentimes causing death from kidney and liver complications.

Paraplegia, while a distressing complication and alarming alike to the parents and the attendants, is, as a rule, recovered from, often spontaneously, although usually it lasts for a long time. An exception to this is found in

the paralysis attending upper cervical disease, where sudden death may take place from crushing of the cord or involvement of the respiratory centre, or, again, where motion and sensation are both involved, incurable paralysis often remains. We have discussed this complication at some length in a former section.

Death often occurs from rupture of an abscess internally, from intercurrent inflammations, such as pneumonia and tubercular meningitis, or from exhaustion following long-continued discharges. The acute exanthemata have a deleterious effect on the progress of caries, and pertussis is a particularly dangerous complication, especially in disease of the thoracic vertebrae, the affection of the spine advancing rapidly, the patient often dying in a paroxysm. Hemorrhage from perforation of large blood-vessels, and suffocation from discharge of abscesses into the lungs, have also been reported as complications with a fatal termination.

#### TREATMENT.

The modern treatment of Pott's disease has attained a measure of excellence attested in a high degree by the much less frequent sight of those distressing deformities which were at one time so common. Much of this is due to the improved means not only of treatment but also of early diagnosis, and to American surgery is largely due the advance in this formerly much neglected branch of medicine. In commencing the treatment of caries of the spine a consideration of the pathological state that we have to deal with is of the utmost importance. It must be remembered that there exists in this condition a retrograde rather than a reparative process, one which in its course is entirely different from the process that follows an acute traumatic lesion. Instead of its being a question of days or weeks, months and sometimes even years are necessary to effect a cure.

There being this long-continued drain on the system, it is obvious that the care of the general health should receive as much attention at our hands as the local condition, which in most instances is but the expression of a general constitutional state.

The principles of treatment to be constantly held in view should be those which aim at (1) improvement of the general health and (2) proper rest to the diseased parts, which embraces the question of correct mechanical support.

Before mentioning those remedies which have been found of service as general reconstructive agents, we would insist, in every case where it is possible, on the importance of fresh air and sunlight, the influence of which has been recognized and has largely aided in bringing about the good results of modern treatment. We have ventured to speak of these agents before mentioning the more generally used medicines, feeling, as we do, that if restricted to a choice, we should select these hygienic means as against internal medication. All such medicines as tend to "bone-building" are of value in this disease, and the selection of one—whether it be cod-liver oil,

the compound syrup of the hypophosphites, phosphorus, or any of the tonics, mineral or vegetable—depends largely on the condition of the individual case and the judgment of the practitioner.

Under the second division all those means which have for their object proper rest of the diseased parts, and which include recumbency and splints or braces, will be considered. The question of rest encounters at present no dissent except from those whose experience and clinical opportunities hardly entitle them to speak with authority. On the mode of giving proper support there is still much difference of opinion.

The treatment by recumbency has had and still has its advocates; its chief merit consists in the fact that in the recumbent position, whether prone or supine, there is no superincumbent weight pressing upon the spine. Where other means are not at hand, it is well that the recumbent posture should be advised; but the utter failure of simple recumbency is easily explained by the difficulty of keeping a patient in bed, in one position, without other means. It is often necessary, even with good mechanical support, that a patient should be confined to bed, especially where exacerbations occur or a paraplegia is in progress. Thus recumbency becomes an aid rather than a mode of treatment, and in this way has a legitimate place in our therapeutics of Pott's disease. The effect of recumbency on the general health, especially in strumous cases, has been variously estimated. Many believe that, by lessening the pain and irritation, the general health has improved. Personally the results obtained by us with other means have been, as a rule, so favorable that we have not had occasion to test its merits from this stand-point.

Extension and suspension are modes of treatment which have been used for a long time, and which have recently been brought into prominence. The former has been used with advantage in cervical disease, but here again the treatment by this method necessitates the recumbent posture, and, unless under exceptional circumstances, we prefer the use of apparatus which allows fresh air and sunlight, while the patient receives proper support at the same time.

Suspension as a mode of treatment in caries of the spine is now generally used simply to allow of the application of plastic supports. As a remedial agent it is of no value independent of support. The idea formerly entertained, that by suspension pathological curves could be obliterated, no longer prevails, it having been demonstrated that, while the physiological curves may be altered or even obliterated, the gibbous curve does not change its character. Suspension should always be practised with the greatest care, and always under the direction and in the presence of the surgeon or an assistant.

**MECHANICAL TREATMENT.**—The plan pursued in the section on diagnosis—namely, the regional one—will be continued in the consideration of treatment. No attempt will be made to consider the numberless mechanical devices used in the treatment of Pott's disease, only those receiving atten-

tion which in the hands of the author have been found to be most easy of adjustment and modification, and which mechanically are capable of meeting the indications in the greatest number of cases. The principles underlying the question of all such apparatus as are used in the treatment of Pott's disease ought to be such as will enable us to secure certain objects. Chief among these are, first, the prevention of undue traumatism; second, the avoidance, as far as practicable, of any movement of the diseased parts; and, last, the prevention, where possible, of increase of pain and deformity. In the present state of our knowledge, there is no apparatus that will satisfactorily accomplish all these indications, and we have already stated why this lesion presents difficulties in the way of treatment, from a pathological stand-point, entirely different from those which present themselves in the treatment of an acute traumatic trouble. Were the anatomical opportunities present, as they are in other articulations, for making proper traction on the diseased parts, there could be no doubt as to the superiority of this method; but the application of continuous traction to certain localities of the spine, the subject of carious inflammation, and the limitation of such traction force, are not, in our opinion, possible.

The treatment of Pott's disease by the plaster-of-Paris jacket, as popularized by Prof. Sayre, has of late years received so many adherents and been so universally accepted as an easy mode of treating this disease that a few words concerning it and similar plastic supports will not be out of place. It is an undeniable fact that any apparatus which gives protection from undue motion and traumatism to certain diseased areas will afford relief, and for giving us a ready means of treating such localities Prof. Sayre's method is of the greatest value. This is particularly true of the dorso-lumbar region, which is the most easily controlled of any portion of the spine.

There are, however, certain disadvantages connected with the use of any plastic material, which are of sufficient importance to receive attention. The encircling of the body in any solid support prevents the surgeon from having the opportunity of carefully watching the progress of the disease, and of estimating the condition of the skin, so that it shall receive proper care. Ulcerations or abscesses may form without his knowledge, and no modification of the apparatus is possible without removal and renewal. The improvement which ensues on the application of any apparatus giving immobility is such that patients, as well as surgeons, are apt to be deceived by the amelioration of the symptoms, and hence escape the strict watch necessary in these cases. Thus the plastic envelope may be borne for months, the disease constantly advancing, and the patient returning only at rare intervals, owing to the absence of the acute manifestations. Among the poor, while it has the advantage of cheapness, the lack of cleanliness is a drawback to the use of the plaster, which those in public practice cannot have failed to notice. It is obvious, therefore, that, while possessing the advantages of economy, of needing less special experience than is required for

the application and modification of steel braces, and of being entirely beyond the control of the patient, these are offset by the disadvantages already mentioned.

It is not an easy thing to apply a proper jacket, and it requires considerable experience to apply an efficient one, its improper application being apt to do great harm. A brief description of its mode of application will suffice here; for a fuller account the reader is referred to Dr. Sayre's work on "Spinal Disease and Curvature," London, 1877.

Suspension is obtained by securing the head in a sling, which is attached to a strong cord playing in a pulley and fastened to a staple driven into a firm place above the patient's head. The patient having previously had a tight-fitting, seamless undershirt applied, suspension is begun. The cord attached to the pulleys is so pulled that the patient's heels are raised from the floor. Freshly-prepared plaster, of the best dental variety, having been rubbed into cross-barred crinoline or other loose-meshed cloth, and rolled into bandages, is then applied. These bandages should before application be placed in water until bubbles cease to appear. The parts most liable to excoriation are carefully padded, and over the abdomen a "dinner-pad" is applied, which is afterwards removed, in order to prevent too great pressure. In females the mammæ are also padded. The bandages should be put on smoothly, and as high as possible, and there should be no inequalities or differences in thickness between the front and the back portion. After the plaster has hardened, the patient is placed on a smooth soft surface, and all rough edges are cut away, making the support as comfortable as possible. Plastic supports of different materials may be applied without suspension.

**Fixative Apparatus.**—Apparatus of different constructions, and representing many principles, are in use; but we have personally had such excellent results from the antero-posterior support as modified by C. F. Taylor, of New York, that in closing the account of treatment we shall speak of this alone. (Plate II.)

The anterior-posterior splint acts upon the principle of a lever, with its fulcrum at the point of deformity. The apparatus is constructed as follows. Two uprights made of the best annealed steel, allowing of easy bending and modification of shape, are connected above by a transverse bar, giving attachment for the shoulder-pieces, and below by a pelvic band. (Fig. 8.) At the location of deformity, and where we wish them to serve as a fulcrum, are placed the pad-plates, which extend for some distance above and below the deformity, and should always be sufficiently long to include the entire area of disease. These are pieces of steel slightly wider than the uprights, and are fastened to the uprights by hinges allowing of easy removal and modification. In some cases they may be screwed to the upright without hinges. They are padded with various materials, ground cork being the best. The uprights should be so widely separated that the pressure of the pad-plates will come on the transverse processes, and never on

PLATE II.

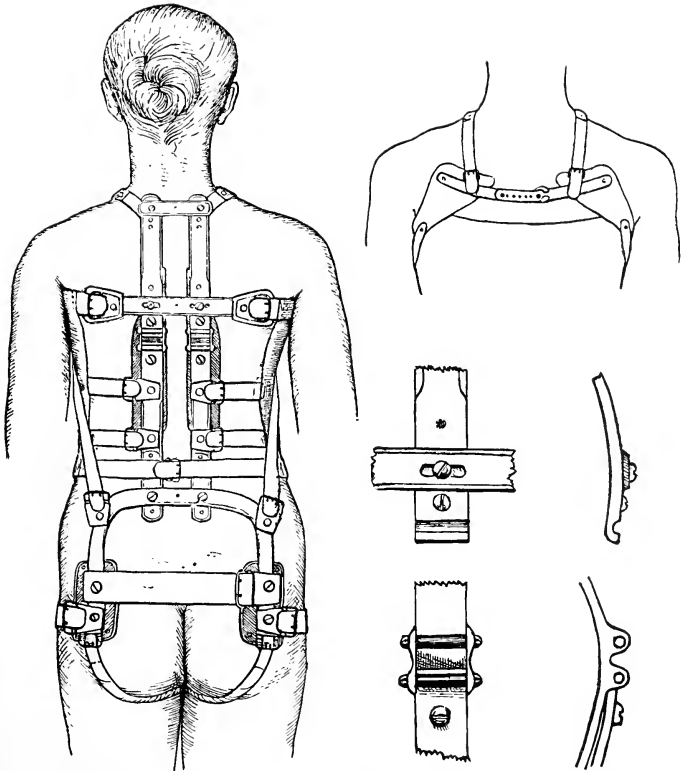

TAYLOR'S MODIFICATION OF DAVIS'S SPINAL ASSISTANT. (From Transactions of the American Orthopedic Association, vol. i., 1889.)



s  
f  
r  
a  
th  
at  
to  
pre  
she  
axi  
con



Diagram of  
of Dorsal  
under the  
the spine  
There

the spinous ones. The uprights should extend high enough to give sufficient leverage, and below to the anal commissure, and the pelvic band should be broad and strong, extending from trochanter to trochanter. Cross-pieces for the insertion of buckles which are attached to the anterior support or apron are placed at points corresponding to the upper border of the axillæ and the lower angle of the scapula, and are attached to the uprights by screws. The anterior part of the support consists of an apron made of strong jean or other similar material, and this serves to fasten the trunk to the apparatus. It reaches from the upper border of the axillæ in front to a point just above the symphysis pubis. Webbing straps are attached at different points for attachment into the buckles of the cross-pieces and pelvic band, and to the shoulder-pieces are attached padded axillary straps.

The apparatus is applied as follows. The patient is placed in the recumbent posture on a hard even couch, with the apron applied to the anterior part of the trunk. The brace, previously fitted to the contour of the spine, is first secured by the pelvic band, and by axillary straps which pass to the lower cross-piece. The upper strap of the apron is then attached to the upper cross-piece. These are the important and essential points of attachment, and should always be made firm. Supplementary webbing straps and buckles may be attached to the apron to give more firmness to the support.

*Principles of the Antero-Posterior Support.*—The antero-posterior support acts, as has already been stated, on the principle of a lever with the fulerum at the location of the deformity (Fig. 9) and acting through the transverse processes. The pelvis is another point of pressure, forming the base of the support, and the resistance is furnished anteriorly by the superior thoracic wall and the traction of the shoulder-straps passing under the axillæ. The power is maintained by the two uprights to support the spine in the same position as is gained by the recumbent posture.

There are certain rules concerning the application of the antero-pos-

FIG. 8.

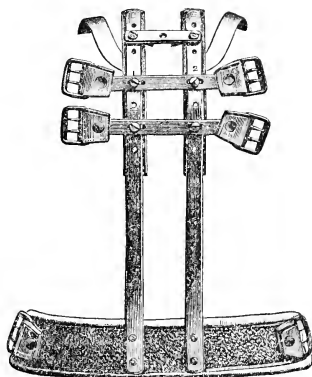

Davis's spinal assistant.

FIG. 9.

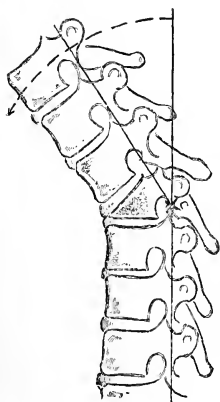

Diagram showing the principle of Davis's support.

terior brace which should be carefully followed. It should always be put on in the recumbent posture. The pressure should be entirely equable over the transverse processes, as made by the pad-plates, and the shoulder-pieces should never press on the shoulders, it being well to leave a small space between the lower surface of the shoulder-pieces and the shoulders. The axillary pads should run in such a direction that no constriction will occur on the axillary vessels and nerves. The brace should be worn day and night, unless removed for some special reason or complication, and in no case should a patient with a carious spine be allowed to assume the upright position without support. Bathing should be done by sponging the body, the patient being recumbent.

For ease of application, for convenience of modification and inspection, for comfort and cleanliness to the wearer, and for maintaining the proper pressure, we know of no apparatus which will compare with the antero-posterior brace. With a little care in adjusting the apparatus, it is within the province of every surgeon to secure with it the most satisfactory results.

*Measurements for Apparatus.*—It is important that the surgeon should be fully equipped not only to measure for his apparatus, but also, when it is sent to him in crude form, to be able to fit it and modify it, so that nothing is left to the instrument-maker but its manufacture.

It is measured for as follows. The patient is placed on a hard surface in the prone position. A strip of flexible lead or block-tin, which retains its form, is laid over the spinous processes from the neck to the anal commissure, and all the inequalities are carefully moulded with the lead. This is then placed on a stencil-board or ordinary pasteboard, and the inner outline traced with great care. This outline is then cut out with scissors, and marks places on the pattern for the position of the pad-plates, cross-pieces, and shoulder-pieces. The pelvic measurement is taken from trochanter to trochanter. The pattern serves a double purpose, being the guide for the instrument-maker, and also a record of the deformity at the time of measurement, and should be kept for future observation.

**TREATMENT OF CERVICAL CARIES.**—Under this head will be included the treatment of caries extending to the seventh dorsal vertebra, as above this point we have, in order to get efficient support, to extend the arm of the lever superiorly. This is best done by means of Taylor's chin-piece, which is secured to the uprights by means of a "keeper and pivot." (Fig. 10.) A modification of this has been devised by Dr. Shaffer, in the form of a ball-and-socket joint (Fig. 11), which allows of motion in all directions, which can be locked at any point, and in which the head can be treated in the position of deformity, and so held and modified from time to time. It is important that the chin-piece (Fig. 12) surmounting the apparatus should not be too large, and its measurement represents only the occipito-mental diameter.

In this region, it must be remembered, we are dealing with a rigid pro-

jection in the middle of a flexible column. It is thus not easy to secure adequate support, especially in the upper dorsal region, and the addition of the superior lever by means of the chin-piece is of great importance.

In the cervical region above the second dorsal vertebra, treatment, as a rule, is attended by excellent results. It is sometimes necessary still further to supplement our chin-piece by the addition of occipital uprights (Fig. 10), which increase the support.

Traction-force is not attempted with the chin-piece, immobility being the object primarily in view. In some cases where the

FIG. 10.

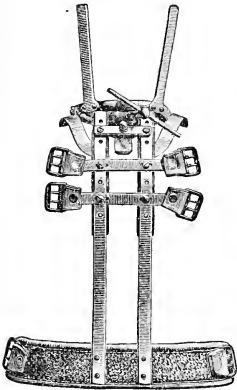

Spinal support, with chin-rest, for treatment of upper dorsal and cervical caries.

FIG. 11.



Ball-and-socket joint for accurate adaptation of chin-rest.

FIG. 12.



Chin-rest.

expense of a steel brace is of moment, disease in this region may be treated by means of a pedestal of plaster encircling the trunk, into which the chin-piece with ball-and-socket pivot can be adjusted. The advantages of the chin-piece in the treatment of disease of the upper portion of the spine are its lightness, firmness, and inconspicuous appearance as compared with the "jury-mast" used in the treatment by plaster of Paris for the same affection.

**TREATMENT OF DORSAL DISEASE.**—Disease of the dorsal vertebrae extending from the seventh to the twelfth is very common. The mechanical difficulties here, as well as in the lumbar region, are much more simple than those involved in the treatment of the upper part of the spine. We have here as a firm basis for our support the pelvis below, while the thorax and axillæ afford excellent locations for securing fixation. It is in dorsal disease that the best results are often obtained, traumatism being reduced to a minimum by the absence of respiratory and other movements, which conflict with proper support in the cervico-dorsal region. In this region sufficient leverage can be obtained by the use of the antero-posterior support without the use of a chin-piece. It is necessary, however, that the anterior support or apron should be firm, and it is often beneficial to reinforce this by the supplementary means of corsets, etc.

**TREATMENT OF LUMBAR DISEASE.**—Here the difficulties of treatment are reduced to a minimum for the same reasons as stated in speaking of lower dorsal caries. The results in this region are usually good, exception sometimes taking place in disease of the last lumbar vertebra. At times,

owing to the form of the deformity, it is difficult to prevent the apparatus from pushing or slipping upward. This may be prevented by attaching perineal straps to the apron, which pass between and are fastened to buckles inserted in the pelvic band. It is especially in the lower region of the spine that any apparatus, whether of steel or plaster, providing proper fixation and support, gives real and at times instantaneous relief to the symptoms. Care must be taken here, as well as in the other localities afflicted with caries, not to remove the splint too early.

TREATMENT OF COMPLICATIONS.—Abscess and paraplegia are the two most common complications of caries of the spine. Of the former, we would simply say that for the surgical procedures necessary for their relief the reader is referred to works on surgery. There is, however, one point to which we wish to call attention. Clinical experience has taught orthopædic surgeons that the course, progress, and treatment of cold abscesses connected with Pott's disease are materially affected by mechanical treatment. Where good support of the diseased parts is given, we are sure that the development of abscesses is less common, their course is more benign, and in many instances they are entirely absorbed. Abscesses of this nature should not be opened too early, and, when opened, it is well to do so in a position suitable for thorough drainage, and under rigid antisepsis.

Paraplegia, as has been already stated, has, when caused by caries of the spine, a spontaneous disposition to recover. Its treatment is still somewhat of a vexed question. Absolute rest in the recumbent posture, with efficient support, has seemed to us to have been of most benefit. The affection being spastic in its nature, the result usually of a direct irritation of the cord, electricity in any form would be strongly contra-indicated. Suspension as a means of treating the paraplegia of Pott's disease has not, up to this date, been sufficiently tried or recorded to give any idea of its status as a treatment for this form of paralysis.

In conclusion, the question of cessation of treatment is of practical importance. With the disappearance of pain and the non-increase of deformity, as evidenced by repeated measurement and comparison of the patterns, with the disappearance of reflex spasm, allowing of free motion above and below the deformity, and lastly with the general improvement in the condition of the patient, it may be considered that solidification has taken place and that the carious process has been arrested. Relapses may occur, or disease may appear in other parts of the spine, and a careful watch should for a long period of time be kept on patients who have been the subjects of Pott's disease.

PLATE I.



SKELETON OF CHILD ABOUT FIVE MONTHS OLD, SHOWING THE LARGE SIZE OF THE CRANIUM AS COMPARED WITH THE THORAX AND PELVIS, THE STRAIGHTNESS AND SMALL SIZE OF THE BONES OF THE LIMBS, AND THE EPIPHYSIAL CONDITION OF THEIR EXTREMITIES. (Photographed by Dr. George McClellan.)

c  
t  
a  
li  
th  
go  
th  
du  
of  
the

hair

It w  
very  
and

The

straig

ridges

in ad

part

with

to be

Fig

of abou

figure

work, a

areolar

skin. T

co-ordin

Cont

bones ar

# FRACTURES AND DISLOCATIONS.

BY JOHN H. PACKARD, M.D.

THE injuries to which the bones and joints are liable in infancy and childhood do not differ essentially from those met with in adult age. Yet they are modified by the condition of the skeleton in its formative stage, and by the circumstances and habits which belong to the early period of life. Hence they present certain peculiar features, which it is the object of this article to set forth.

Every one is familiar with the vast changes in external aspect undergone by the human body in its progress from infancy to manhood; but these changes are not greater than those which take place in the skeleton during its development. In size, form, proportion, and structure, the bones of the child at birth are as different from those of a boy ten years old as the latter are from those of an adult man.

Plate I. presents a striking view of the peculiarities of the skeleton in the very young child. It will be noted that the head is proportionately very large, the thorax and pelvis are very small, and the limbs, especially the lower, are very short. The shafts of all the long bones are seen to be straight and slender; they have none of the strong ridges and other markings which appear in them in adult life; their extremities are for the most part but slightly enlarged, and are capped each with a thick layer of cartilage, at a later period to be converted into bone, as the epiphyses.

Fig. 1, from a photograph, represents a child of about the same age. The plumpness of the figure wholly conceals the slender bony framework, and is due to the thick layer of fat and areolar tissue which everywhere underlies the skin. The muscular movements are very quick, but there is no power of co-ordination, and no stress is brought to bear upon the bones.

Contrasting with this the likeness of a boy four years old (Fig. 2), the bones are seen to have gained greatly in length as compared with the size

FIG. 1.



Child about seven months old.  
(McClellan.)



of the head. The tissues overlying them are in relatively small quantity, the fatty layer being much lessened; and the body and limbs have assumed a condition fitted for the incessant activity natural to this period of life. The clavicles, as well as the extremities of the long bones at the shoulder-, elbow-, knee-, and ankle-joints, can be perceived.

At ten years of age (Fig. 3) a further approach to the adult type may be noted. The outline of the figure seems to suggest the stronger and more

decided markings of the bones and muscles; the limbs have grown more rapidly in proportion than the head and body, and the whole framework has increased; childhood is about to cease, adolescence to begin.

The osseous system is therefore at first in a rudimentary condition, and is actually protected by the soft parts; but its developmental changes go on rapidly, it grows up to and past them, and becomes fitted to be not only a protection to them, but also the mechanism by means of which all the outward activities of the body are carried on.

Along with its increase in size there is also a marked change in the structure of the skeleton. The walls of the shafts become thicker and denser, the cancellous structures at the extremities are more clearly defined, and the

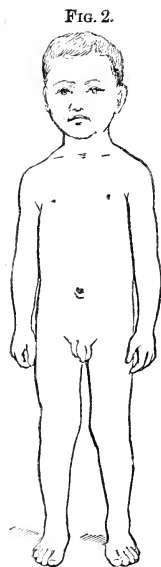

Boy four years old.  
(McClellan.)

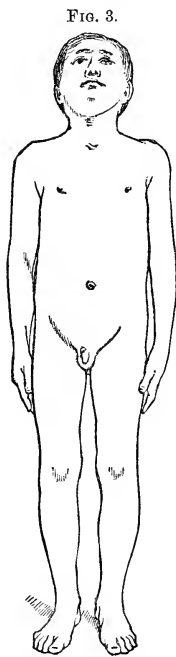

Boy ten years of age.  
(McClellan.)

medulla is less vascular. Some of the epiphyses are still ununited to the diaphyses until adult age is fully reached.

During the whole of this developmental stage the periosteum is very thick, and its blood-supply is abundant. It is more loosely attached to the bones than after they have attained their growth, and hence in some cases of injury is stripped up to a considerable extent.

As to the conditions and habits of life in childhood, they in some respects involve more, and in others less, liability to fractures and luxations than those of adults. Children are in general more carefully guarded, and in their pursuits less called upon to expose themselves to accidental violence.

Yet they combine the heedlessness of ignorance with the timidity of weakness; they rush into dangers which they do not appreciate, and when anything befalls them they are helpless. In their plays they are reckless, inconsiderate, and venturesome; they run across crowded streets, climb trees, and in many ways expose themselves to risks which older people avoid. The very habit of being watched over by others makes them less able to take care of themselves.

On the whole, however, children are much less liable to fractures than adults are; and they are in a still greater degree exempt from luxations. Not only is the actual number of cases observed in early life less, but, as the young constitute so large a majority of the population, the relative proportion is much smaller than it would at first appear to be.

Physically, there would seem to be very little difference between the two sexes in childhood; but girls are usually somewhat more carefully watched, and they are in many cases restrained from the rougher pursuits in which boys are free to indulge. Hence after the period of infancy there is a predominance of males among the subjects of fracture and of dislocation, which becomes even more marked at puberty, and obtains throughout adult age.

There are some fractures, often met with in grown persons, from which children are almost or altogether exempt; and, on the other hand, there are some which occur exclusively in early life. In like manner there are differences between children and adults in the relative frequency of the various luxations, although here the lines are not quite so clearly drawn as they are in regard to fractures. But these points will be sufficiently discussed, and to greater advantage, in considering the lesions of each part of the skeleton.

---

## FRACTURES.

The different bones of the skeleton vary greatly in their liability to fracture, in children as in adults. But those which are most frequently broken in childhood are not those which are so in later life. This is well illustrated in the tables given by Gurlt.<sup>1</sup>

From these it appears that there are from the first to the tenth year one hundred and ninety-six fractures of the upper extremities and sixty-two of the lower, and from the twenty-first to the thirtieth year one hundred and twenty-five fractures of the upper extremities and eighty-four of the lower. That is, between the first and tenth years seventy-six per cent. of the fractures involved the upper extremities, twenty-four per cent. the lower; whereas between the twentieth and thirtieth years the upper extremities

---

<sup>1</sup> Handbuch der Lehre von den Knochenbrüchen, Bd. i. p. 13.

were affected in only sixty per cent., the proportion of the lower having risen to forty per cent.

Again, it would appear, from comparison of a number of tables from the most reliable sources, that in adults the bones of the leg are oftenest broken, then the femur, the humerus, the bones of the forearm, the clavicle, the ribs, the bones of the face (including the lower jaw), and the patella, in the order named. From the experience of the Children's Hospital of Philadelphia<sup>1</sup> it will be seen that this ratio does not obtain in early life. Among one hundred and four cases of fractures treated in the wards, there are noted of the femur, thirty-four, or something over thirty-two per cent.; of the forearm, twelve, or eleven and a half per cent.; of the humerus, eleven, or ten and a half per cent.; and of the tibia, nine, or about eight and three-fourths per cent. Taking these along with the cases treated in the dispensary service of the institution, we have an aggregate of five hundred and four cases, of which there were:

Of the forearm . . . . .	163	Of the skull . . . . .	6
“ clavicle . . . . .	118	“ nasal bones . . . . .	5
“ humerus . . . . .	113	“ lower jaw . . . . .	5
“ femur . . . . .	41	“ scapula . . . . .	3
“ leg . . . . .	26	“ crest of the ilium . . . . .	1
“ fingers . . . . .	17		
“ metacarpus . . . . .	6		<u>504</u>

Coulon,<sup>2</sup> among one hundred and forty fractures treated in one year at the Hôpital des Enfants Malades in Paris, found fifty of the forearm, twenty-six of the femur, twenty-one of the clavicle, eighteen of the elbow, and fourteen of the leg.

In the report of Langenbeck's Klinik and Poliklinik from May 1, 1875, to July 31, 1876,<sup>3</sup> we find some curious facts. Thus, it would appear that out of five hundred and twenty-eight fractures treated, two hundred and forty-five were in persons in the first decade of life, and only one hundred and one in persons in the second. These fractures affected the skeleton as follows:

FIRST TO TENTH YEAR.		ELEVENTH TO TWENTIETH YEAR.	
Forearm . . . . .	71	Forearm . . . . .	51
Clavicle . . . . .	70	Humerus . . . . .	15
Femur . . . . .	56	Leg . . . . .	15
Humerus . . . . .	39	Clavicle . . . . .	9
Leg . . . . .	9	Small bones . . . . .	9
	<u>245</u>	Femur . . . . .	2
			<u>101</u>

Again, Beek<sup>4</sup> gives the records of fifteen years' practice in the Children's Hospital in Basle. There were treated during that time, in two

<sup>1</sup> Reports, 1878 to 1887 inclusive.

<sup>2</sup> *Traité clinique et pratique des Fractures chez les Enfants*, Paris, 1861.

<sup>3</sup> Langenbeck's *Archiv für Klinische Chirurgie*, 1877, Supplement.

<sup>4</sup> *Jahrbuch für Kinderheilkunde*, 1886.

hundred and thirty-three children, two hundred and forty-seven fractures, distributed as follows :

In the femur . . . . .	90, or 36.4 per cent.
“ humerus . . . . .	52, or 21.1 “
“ forearm . . . . .	44, or 17.8 “
“ leg . . . . .	25, or 10.1 “
“ clavicle . . . . .	18, or 7.3 “
“ cranium . . . . .	7, or 2.8 “
“ lower jaw . . . . .	3, or 1.2 “
“ finger . . . . .	3, or 1.2 “
“ upper jaw . . . . .	2, or 0.8 “
“ metacarpus . . . . .	2, or 0.8 “
“ pubis . . . . .	1, or 0.4 “

Upon comparison of these several sets of statistics, it will be perceived that they present discrepancies for which, in the absence of details, it is not easy to account. It is probable that they depend partly on differences in the rules of admission in the various institutions, partly on the inclusion of out-patients in some of the reports, and, it may be, in a measure upon the prejudice for or against hospitals prevailing among certain populations.

ETIOLOGY.

The causes of fracture are divided into the *immediate* and the *predisposing*; the former class including all the kinds of violence under which bones give way, while to the latter belong all the conditions, whether of the system at large, of the skeleton, or of individual bones, which either expose the latter to fracturing forces, or so influence their texture as to make them yield more readily.

**IMMEDIATE CAUSES.**—*Direct violence* acts upon the bone at the point where it breaks: a blow, the passage of a wheel over the limb, any crushing force, are instances of this kind. *Indirect violence* is transmitted through some length of the bony structure, as when the clavicle is broken by a fall on the palm of the hand. Here the mechanism is often plainly leverage, sometimes a twist being also impressed upon the bone. *Muscular action*, if sudden and excessive, as in cases of convulsion, may cause fracture. *Avulsion*, or the tearing off of a small fragment of bone by stress put upon a ligament or tendon attached to it, has been observed in children in a few instances.

**PREDISPOSING CAUSES.**—These may be considered under the head of—

*Fragility of Bones.*—There are some children who seem to have an especial liability to fracture; their bones are brittle, and give way to very slight forces. Certain constitutional disorders have been assigned in some of these cases.

Berkeley Hill<sup>1</sup> mentions the case of a child six weeks old, with symp-

<sup>1</sup> Syphilis and Local Contagious Disorders, 2d ed., London, 1881.

toms of inherited syphilis, whose left humerus gave way by the mother catching its arm in a hole in the towel with which she was drying it; examination showed the right clavicle bent and deformed from a fracture at some unknown previous time. He refers to a case recorded by Porak of a fracture sustained during its birth by a syphilitic child. But these cases are certainly not common.

Scrofula has been sometimes regarded as a cause of fragility of the bones, but there is no evidence that such is the fact, although Dupuytren is quoted by Malgaigne as having seen a case which was so interpreted.

Rickets, or rachitis,—a rare disease in the United States,—would seem to have been justly regarded as affording the explanation of some cases.<sup>1</sup>

A curious case was reported by Collins,<sup>2</sup> in which a deficiency of casein in a mother's milk seemed to have given rise in her child to a condition allied to rickets. This child was seen on the eleventh day after birth, when the left femur presented every appearance of having been fractured and recently united. Seventeen days afterwards the left humerus was found to be broken; three weeks later still, the right humerus, and four days after that, the right femur. Each fracture was near the middle of the shaft; all the bones were curved. Union took place readily.

In one instance, reported by Parker,<sup>3</sup> a girl aged six years seemed to have become the subject of fragility of the bones from general deterioration of health, the result of whooping-cough and measles.

In the same article there is a very remarkable case recorded, in which a girl of fifteen, who had a small tumor on the thigh, was descending a staircase, when the femur gave way at the junction of its middle and lower thirds. Union seemed to take place, but the bone yielded again from her starting in her sleep. On her death five months later, the place of the callus was occupied by a mass of encephaloid cancer, which had infiltrated the lower portion of the bone also; the lungs were full of cancerous deposits. I believe this case to be unique, in the youthfulness of the patient.

Sometimes there is no assignable cause, the brittleness seeming to be merely a peculiarity of structure of the bones. Arnott,<sup>4</sup> Stanley,<sup>5</sup> Gibson,<sup>6</sup> Goddard,<sup>7</sup> and Graham<sup>8</sup> have reported cases of this kind. In a few instances fragility of bones has seemed to be, as it were, a family failing. The girl mentioned by Arnott had had at fourteen years of age her thirty-

<sup>1</sup> Such are Jaquemille's case, quoted by Malgaigne; Barwell's (*British Medical Journal*, December 9, 1882); Davies-Colley's (*ibid.*, April 5, 1884). See also Lonsdale on Fractures, p. 21; Coulon, *Traité clinique et pratique des Fractures chez les Enfants*, Paris, 1861.

<sup>2</sup> *British Medical Journal*, May 13, 1882.

<sup>3</sup> *New York Journal of Medicine*, July, 1852.

<sup>4</sup> *London Medical Gazette*, June 15, 1833.

<sup>5</sup> *Treatise on Diseases of the Bones*, London, 1849.

<sup>6</sup> *Surgery*, 8th ed., 1850, vol. i. p. 234.

<sup>7</sup> Gibson, *op. cit.*, p. 236.

<sup>8</sup> *Boston Medical and Surgical Journal*, May 15, 1884.

first fracture; her sister, six years of age, had already had nine fractures. Goddard's patient, a boy aged twelve, had had fourteen fractures; his mother had had six, and his brother at thirteen had had thirteen. Graham's had had eighteen fractures in as many years, his father had had fourteen, a cousin twenty-one; and an uncle was said to be a "bone-breaker." Pritchard<sup>1</sup> reports the case of a child, fully developed and seemingly healthy, who when two days old was found to have the left humerus and femur fractured. On the next day the right humerus gave way from catching in the bedclothes, and at the twenty-first day the right femur was found broken. Union was progressing well at the time of the report. It is said that two uncles of this child, and three children of a brother, had been similarly affected.

Three generations were thus affected in a case reported by Pauli,<sup>2</sup> and in another by Greenish.<sup>3</sup>

On the other hand, Malgaigne quotes from Saviard the case of a very young child in whom the softening was confined to the femora; and a similar limitation has been reported by Howell,<sup>4</sup> in a child whose first fracture occurred in its second year, the number amounting to seven by its sixteenth.

#### VARIETIES OF FRACTURES.

Fractures as they occur in children are classified as in adults. *Simple* fractures are such as do not communicate directly with the air; if the soft parts are lacerated by the fracturing force, by one or both of the fragments being forced through them, or by subsequent morbid process,—ulceration, suppuration, or sloughing,—so that the air finds access to the broken ends, the injury is said to be a *compound* fracture.

When portions are broken off from one or both of the main fragments, the fracture is said to be *comminuted*. If, in addition to the fracture, there is other serious lesion in its neighborhood, such as luxation of a joint, extensive laceration of soft parts, or rupture of vessels, the injury is said to be a *complicated* fracture. If several different portions of the skeleton are broken at once, as sometimes happens in falls from a great height, or in cases of crushing, the case is said to be one of *multiple* fracture.

The terms *transverse*, *oblique*, and *longitudinal*, as applied to these injuries, need no other explanation than that they refer to the relation of the breakage to the long axis of the bone involved.

When a bone is broken entirely through, so as to be in two portions, the fracture is said to be *complete*. But, and in children especially, the separation may involve some of the fibres only, the rest retaining their continuity, although perhaps bent; and in this case the fracture is termed *partial* or

---

<sup>1</sup> Lancet, September 1, 1883.

<sup>2</sup> Quoted by Gurlt.

<sup>3</sup> British Medical Journal, June 26, 1880.

<sup>4</sup> Atlanta Medical and Surgical Journal, April, 1884.

*incomplete.* Another term has sometimes been used to designate these lesions; the bones so injured have been said to be *bent*. Now, the possibility of an actual bending of a bone, without fracture, has been questioned; and such a thing certainly must be very rare, occurring only in the earliest infancy. The tubular shaft of the bone is supposed to be crumpled up at the concavity of the bend, while at the convexity there is an angulation, with or without tension,—an idea which will be at once comprehended by bending a quill. But the question is not a practical one, and need not be further discussed here. What we do occasionally meet with in practice, in children, can be best defined as incomplete, partial, or “green-stick” fracture; the latter term having been applied to it more than a century and a half ago, by Turner<sup>1</sup> and Wiseman.<sup>2</sup>

*Fissures* or *cracks* are sufficiently described by the terms themselves, which have the same meaning as in their common use.

*Sprain-fractures*—described under this name by the late Mr. Callender—are those injuries which consist in the tearing off of a small portion of a bone, such as the tubercle of the tibia, by tension put upon ligamentous or tendinous structures. They are lesions not so much of childhood as of youth.

*Impacted* fracture is one in which the fragments are interlocked, one being driven into the cancellous structure of the other.

There is still another lesion to be spoken of, which may be said to be peculiar to childhood and youth,—*epiphysial disjunction*, or separation of an epiphysis, the breakage passing mainly or entirely through the not yet fully ossified material intervening between this and the diaphysis or shaft. There has been some objection to thus designating these injuries, on the ground that the separation is very seldom limited to the cartilage-like layer which is interposed between the shaft and the epiphysis. Richet and others declare that the cartilage and bone are continuous, and not merely contiguous. In Richet’s words, “when, in consequence of violence from without, there is separation at this point, it is a veritable fracture, such as takes place in the continuity of the bones.” This question is, however, one of no great importance. The fact must be admitted that in many cases there is a solution of continuity by which a growing or not fully developed bone is separated into two portions, one being the diaphysis and the other the epiphysis; and it is a matter of very little real moment whether the lesion be or be not absolutely limited to the interposed layer of cartilage. From my own observations (and I have within twenty-four hours had a case of such separation of the lower epiphysis of the femur), I should say that usually the epiphysis and cartilage are forced off, leaving the end of the diaphysis by itself. The mere fact of the detachment of a small splinter of bone from the latter does not seem to me to vitiate the character of the injury as a separa-

<sup>1</sup> Art of Surgery, 2d ed., 1725, vol. ii. p. 183.

<sup>2</sup> Chirurgical Treatises, 6th ed., 1734, vol. ii. book vii. p. 239.

tion of the epiphysis. The end of one fragment belongs to the diaphysis, the other is the epiphysis, cupped and lined with cartilage, so as to fit its convex end.

Fig. 4 represents diagrammatically the shaft of a long bone, with its epiphysis; the shaded portion being the intervening layer of osteogenetic

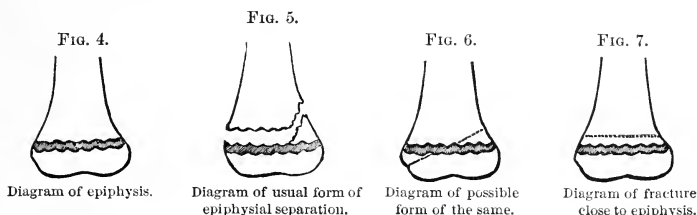

material. A true disjunction of the epiphysis would occur if the line of separation were to pass through this intervening layer only. What generally happens is that the fracture involves a portion of the shaft, as in Fig. 5, or a portion of the epiphysis, or both, as in Fig. 6. Or there may be a fracture through the shaft alone, very near its extremity, so that without very careful examination the mistake of supposing the epiphysis alone to be separated might readily be made. Fig. 7 is a diagram of such a fracture. In all these cases there is apt to be a more or less extensive stripping up of the periosteum from the shaft of the bone, and, whether from this cause or by reason of damage to the nutrient arteries, the subsequent growth and development of the bone have seemed in some instances to be interfered with.<sup>1</sup> Otherwise, these injuries do not materially differ from fractures of the ordinary kind. The subject will be again referred to in connection with the several bones.

Owen<sup>2</sup> suggests that epiphysal separations take the place, in childhood, of luxations. He thinks it may be assumed that an epiphysis toward which the nutrient artery runs is joined to the shaft soon after puberty; others not till about the twentieth year.

Gurlt quotes from Poupart the remarkable statement that in 1699, during an epidemic of scurvy in the Hôpital Saint-Louis, in Paris, separations of the epiphyses were very commonly observed, occurring from very slight causes, such as turning in bed. The bones seemed of more than normal thickness, and remained swollen, but without pain.

**INTRA-UTERINE FRACTURES.**—These injuries may be caused by blows or other violence inflicted upon the child through the walls of the mother's

<sup>1</sup> Hutchinson, Transactions of the Pathological Society of London, vols. xiii. and xvii.; Holmes, Surgical Treatment of the Diseases of Infancy and Childhood, 1868, p. 240. See also an excellent article by P. Bruns, "Ueber traumatische Epiphysentrennung," in the Archiv für Klinische Chirurgie for 1882. This writer refers to a previous article, by P. Vogt, on the influence of these injuries on the growth of the long bones.

<sup>2</sup> Medical Times and Gazette, November 14, 1886.



belly, as in a number of recorded instances. The clavicle, forearm, femur, and leg have been thus broken. Sometimes union has already taken place at the time of birth; but Mr. H. Smith has reported<sup>1</sup> a case in which the tibia and fibula, broken within the womb, were still ununited when the child was seven years old. In one instance, recorded by Guersant, a fracture of the leg had united at an angle, and resection was performed by Malgaigne, with a fatal result. Beck<sup>2</sup> records the case of a girl born with a united (intra-uterine) fracture of the leg; the two fragments had been joined at a right angle, and osteotomy was successfully performed at the age of ten months. Children have been born with multiple fractures; but in these cases there is always reason to suspect disease, or at least defective nutrition, of the bones.<sup>3</sup> Sometimes it would seem likely that the bones have been broken by convulsive movements of the fœtus; and in one or two instances the entanglement of the limbs of twins has been assigned as the cause of fracture. Branfoot<sup>4</sup> has reported a case in which, the mother having been for six weeks under treatment for acute articular rheumatism, a child was born dead, having fractures of both femora and of both bones of each leg; the broken bones were united at right angles, new bone being deposited in each case in the angle.<sup>5</sup>

**FRACTURES DURING BIRTH.**—These are sometimes, as in a case recorded by Vander Veer,<sup>6</sup> caused by the powerful expulsive contractions of the uterus. More generally, however, they are produced in the course of obstetric operations; they cannot always be prevented by the utmost skill or care on the part of the accoucheur. The humerus and the femur are especially liable to injury in this way; and the bones of the skull may be crushed in the grasp of the midwifery forceps.<sup>7</sup>

#### PHENOMENA AND SYMPTOMS.

*Pain* is always present in cases of fracture, though it may not be constant. Very young children, who cannot point out the seat of trouble, will merely cry and fret, until perhaps by chance it is observed that the handling of a certain part always increases their complaints.

*Loss of power* in the part, in some very active and restless infants,

<sup>1</sup> Transactions of the Pathological Society of London, 1867, vol. xviii.

<sup>2</sup> Loc. cit.

<sup>3</sup> See Linck, Archiv für Gynaekologie, Berlin, 1887.

<sup>4</sup> British Medical Journal, January 21, 1888.

<sup>5</sup> The reader may consult with advantage an excellent paper by Brinton, in the second volume of the Transactions of the American Surgical Association, containing two new cases of intra-uterine fracture, and fifty-one collected from various sources.

<sup>6</sup> New York Journal of Medicine, May, 1847.

<sup>7</sup> See Bouchut, Traité pratique des Maladies des Nouveau-nés, etc.; Delore, Dictionnaire encyclopédique des Sciences médicales, article on Fractures in the Fœtus; Kuestner, Die typischen Verletzungen des Extrem. Knochen des Kindes durch den Geburtshülfe, Halle, 1877; Ruge, Zeitschrift für Geburtshülfe und Frauenkrankheiten, Berlin, 1876; A. R. Simpson, On Diastases in the Bones of the Lower Extremity of the Fœtus, produced by the Accoucheur, in the Edinburgh Medical Journal, June, 1880.

would at once attract notice; and those who have learned to speak are apt to mention this and the pain together.

*Deformity*, in the long bones, may or may not be present, the thick and tough periosteum sometimes holding the fragments very firmly together. Should this membrane have been torn, however, the pull of the muscles is apt to distort the limb to a very marked degree. When the existence of fracture is suspected, the child should be stripped and carefully examined.

*Swelling* may take place very promptly, but is sometimes only slight. One of my own children, at the age of six, had his humerus broken by direct violence; but there was no displacement until he had a fall two weeks later, and no swelling though as to attract attention at any time. His only symptoms during those two weeks were pain and loss of power.

*Echymosis* is less apt to occur in children than in adults, probably because the thick periosteum is less readily torn, and because the greater relative mass of the soft parts renders the veins less liable to rupture.

*Preternatural mobility* is very often to be detected. It may be at abnormal points, as in the middle of the thigh or leg, or in abnormal directions, as when the forearm can be moved laterally on the arm, or the leg on the thigh. Sometimes, as in cases of fracture near joints, or involving them, the muscular resistance may be such as to restrict mobility.

*Crepitus*, as in adults, affords conclusive proof of the existence of fracture. It is apt to be a softer and less distinct sound, by reason of the smallness and toughness of the bones concerned, so that their broken ends are likely to be less sharply serrated; moreover, it is masked by the comparative thickness of the periosteum, and, indeed, of the whole mass of soft parts.

Whenever there is doubt about the existence of fracture, or difficulty in determining its exact seat, it is better to give the child an anæsthetic and to make a thorough examination. Often a child will be so resolute in his resistance to the surgeon that a satisfactory knowledge of the case cannot otherwise be arrived at. With the aid of ether, and with complete exposure of both the injured and the sound side, the diagnosis may be made, reduction effected, and proper steps taken for the maintenance of the fragments in position. An essential point, in injuries about the joints, is to ascertain whether or not dislocation exists; and this is sometimes impossible unless with complete anæsthesia.

#### MODE OF REPAIR OF FRACTURES.

The union of broken bones takes place in children, as a general rule, with great readiness. All formative processes are especially active at this period of life, the tissues are very vascular, and the amount of reparative material deposited is apt to be much in excess of what is needed. Such superabundant callus is, however, very readily absorbed again, and it is often difficult to detect any traces of a fracture which had seemed likely to be followed by permanent deformity.

Defects in the process of repair, delayed union, non-union, and pseudarthrosis or false joint,—fortunately, not very common among children,—will be spoken of in connection with the fractures of special bones. The methods of treatment of these conditions have been so fully discussed in works on general surgery, as well as in those devoted to the subject of fractures, that it would be needless to devote space to their consideration here.

#### TREATMENT.

If it were possible for the surgeon, after accurate reduction of a fracture, restoring the fragments exactly to their normal relation, to hold them thus until nature should have completed the reparative process, the result would be perfect. This, of course, cannot be done; and therefore we must resort to the next best thing, by substituting for the surgeon's hands apparatus which shall keep the parts controlled and prevent the recurrence of deformity. Hence in children, as in adults, we employ splints of various kinds, fitted to the parts as accurately as possible; the immovable apparatus; sometimes extension and counter-extension.

By reason of the small size of the parts, the reduction of the fragments is generally comparatively easy in children, and they are, of course, more readily handled and lifted. But the retention is rendered difficult by the want of purchase afforded. And the restlessness of many children, with the eel-like facility which they possess in getting rid of restraint, as well as the impossibility of making them feel the importance of avoiding displacement, must always constitute an element of uncertainty as to results. Moreover, the delicacy of the skin renders it very apt to become irritated, even to ulceration, by pressure: so that special care is needful in the adjustment of apparatus.

The same general principles apply here as in the case of adults, and will be developed in the discussion of the special fractures.

#### SPECIAL FRACTURES.

**FRACTURES OF THE BONES OF THE FACE.**—Fractures of the nasal bones very rarely occur in children, for obvious reasons. An accident very similar, however,—the separation of the cartilages from the bones,—is not uncommon: several instances of it have come under my own observation. It may result from falls or blows, and is attended by pain, often very severe, swelling, deformity, and abnormal mobility. Bleeding, sometimes profuse, is apt to occur, from rupture of the mucous membrane, and the contusion of the skin is followed by ecchymosis which may be very extensive. Crepitus is usually to be elicited, although it is not very marked.

Whether restored to their proper place or not, the cartilages readily unite again to the bones. Should the deformity have been left uncorrected, it becomes more pronounced as life advances, and may be a life-long source of annoyance: the utmost care should, therefore, be taken at the outset in

restoring the normal relations of the parts. Boyer<sup>1</sup> relates the case of a girl, aged eight, whose nose was fractured by the kick of a horse; reduction was postponed until the subsidence of swelling and inflammation, but was then found impossible; and not only was the nose permanently flattened, but an incurable lachrymal fistula also resulted.

Evaporating lotions may be used for one or two days, until the first irritation has subsided. Bleeding, if very free, may be checked by pressure made with a director wrapped around with cotton and passed into the nostril; or the child, if old enough, may be induced to draw hot water up into the nose. Some children have very wide nostrils, and pressure can be readily made, in which case it is best.

When the swelling has subsided, or as soon as the state of the parts can be made out, means should be adopted for the correction of any deformity that may exist. In one case I found that after moulding the parts into shape they remained so, and no retentive appliance was needed. But if there is much mobility, a quill should be cut of suitable length, wrapped around with absorbent cotton, and gently introduced into the nostril so as to act as an inside splint. Both sides may require this treatment, and then one or two narrow strips of rubber adhesive plaster may be applied outside, so as to keep the injured parts closely confined. By means of an arrangement of this kind the interference with breathing which would ensue upon the employment of a solid plug may be avoided. Occasional inhalations of steam may be useful to prevent the blocking of the tube by inspissated mucus.

In three or four days, or perhaps sooner, the cotton becomes saturated with thin mucus, and comes away, or may be withdrawn, and another inserted in its place for a day or two, after which it may be dispensed with. But for some time it is necessary to use care, in blowing the nose, for instance, lest the displacement be reproduced.

**Fracture of the lower jaw** is very rare in children, the small size of the bone affording very little leverage. When it is met with, it is generally the result of a severe blow or fall. I recently saw a case in which a girl about eight years of age was thrown out of a carriage, the horses having run away; she struck her face violently against an iron post, and sustained a compound comminuted fracture of the lower jaw on the right side. Some necrosis followed, but she recovered without serious deformity. Campbell<sup>2</sup> has recorded the case of a boy, aged nine, who was knocked down and trodden by a horse; he had a double compound comminuted fracture of the body of the lower jaw at the left side, which united well, a few bits of necrosed bone coming away. Lonsdale says he saw the lower jaw broken at the symphysis in a child aged ten, but gives no details. Caswell<sup>3</sup> has

<sup>1</sup> *Traité des Maladies chirurgicales, etc.*, translated by A. H. Stevens, New York, 1816, vol. ii. p. 46.

<sup>2</sup> *New York Journal of Medicine*, May, 1858.

<sup>3</sup> *Fractures in the Rhode Island Hospital, 1868-1878.*

reported the case of a boy, aged eight, who had a double fracture, one on each side of the symphysis, from a fall. Newland-Pedley<sup>1</sup> records a fracture at the side of the right lower canine tooth in a boy aged eight, who was run over. In the record-book of the Children's Hospital of Philadelphia there is noted a fracture of the lower jaw at the left of the symphysis in a boy aged four, run over by a cart. And Gregory<sup>2</sup> has reported a case of fracture of the lower jaw by direct violence in a child aged two years.

A good deal of shock is apt to attend an injury of this kind, and the brain may even suffer fatally. Wounds or contusions of the soft parts, within and without the mouth, are almost invariably present, and complicate the treatment. The lines followed by these fractures are very various, and not always easy to determine, on account of the rapid swelling which ensues. A greater or less degree of comminution of the bone is apt to occur.

By reason of the small size of the part, it is often difficult, and sometimes impossible, to control the fragments thoroughly, and keep them in proper relation to one another. As to mere deformity, this is not so grave a matter, as the projections of the fragments will become rounded off in time, and the appearance of the face will be better than might at first seem likely. But a more serious trouble arises from the fact that the direction of the teeth may be so changed as to prevent their accurate contact with those of the upper jaw, so that mastication will be interfered with. Hence not only should every effort be made to secure the fragments in due apposition, but the parents should be warned to have the process of eruption of the teeth carefully watched by a competent dentist, in order that any error in their position may be corrected.

The treatment consists in the coaptation of the fragments, and their retention by means of what is known as Barton's bandage. A small roller should be firmly applied in the manner shown in Fig. 8, beginning at the occiput, passing over the top of the head, down around the face, over the top of the head again to the occiput, and then around the chin to the

FIG. 8.



FIG. 9.

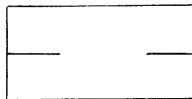

Splint cut out.

FIG. 10.



Cup for the jaw.

starting-point. Along with this may be used a cup-shaped pasteboard splint to support the chin. (Figs. 9 and 10.) Sometimes, as in Newland-Pedley's case, a vulcanite plate is made to be applied over the teeth of one or both jaws; if the latter, there are, of course, two plates, connected by vulcanite

<sup>1</sup> British Medical Journal, March 16, 1889.

<sup>2</sup> St. Louis Medical and Surgical Journal, May 20, 1880.

pillars. A long slip of cork, with indentations for the teeth, may be used in like manner.

Much ingenuity has been bestowed upon the invention of apparatus for the retention of the fragments in these injuries in adults, and other plans may be found discussed at great length in works on general and oral surgery.

Allan<sup>1</sup> refers to a remarkable case related by Morand in 1727 to the Académie Royale; it was that of a young girl who, in consequence of a fracture of the jaw, became affected with an exostosis which proved fatal.

**Fractures of the upper maxillary bone** are very rare in children. I have seen, in a boy aged six, a portion of the alveolar arch in front detached by a fall against a step; he bled profusely for a time, but complete union ensued. Hamilton mentions a case in which a block of wood fell upon the face of a child three weeks old, and forced the nasal processes outward.

The palatal portion of this bone would seem to be thoroughly protected from violence; but a case is reported by Griffin<sup>2</sup> in which a boy two years and eight months of age fell down while playing with a piccolo flute, the sharp end of which struck and fractured the hard palate. A plate was applied, attached to the molar teeth, and a good result ensued.

Sometimes, by very great violence, children sustain extensive injuries, the face being, as it were, smashed. Wiseman<sup>3</sup> recorded a case of this kind, in which a boy aged eight was kicked in the face by a horse. Another is related by Malgaigne, of a like accident, in which the condition many years afterwards was as follows. "The nasal bones were destroyed; the anterior portion of the alveolar arch, and most, if not all, of the vault of the palate, had likewise disappeared. He had no nose nor mouth; the two lips being fastened together by a thick and firm cicatrix, the chin was continued up to an oval opening formed between the two ascending processes of the maxillary bones as high as the frontal. By this one opening the patient breathed, spoke, ate, and drank; when a piece of bread was put into it, the tongue was seen to come up, and to carry it down to the molar teeth, which performed their functions very well."

Agnew<sup>4</sup> records an instance of injury apparently even more severe, but more favorable in its result. The boy was caught between two railroad-cars. "The whole face was disjoined from the head. The upper jaws were greatly comminuted, the inferior maxilla was broken into four pieces, and a number of ragged wounds involved the soft parts of the face. Notwithstanding this extensive mutilation, all the fragments of the upper jaw united; a portion of the lower maxilla, being in a great measure detached from the bone, became necrosed and was removed." The deformity remaining after recovery is well represented in Fig. 11.

Cotting<sup>5</sup> has reported a case in which a boy aged four years and three

<sup>1</sup> System of Practical and Operative Surgery, Edinburgh, 1821, vol. ii. p. 36.

<sup>2</sup> New York Medical Record, July 2, 1887.

<sup>3</sup> Chirurgical Treatises, 6th ed., 1734, vol. ii. book vii. p. 253.      <sup>4</sup> Surgery, vol. i.

<sup>5</sup> American Journal of the Medical Sciences, October, 1854.

months was run over, a carriage containing five persons passing over his face. Besides great laceration, the right malar and upper maxillary bones were broken from their attachments, and driven downward and backward for at least half an inch. The lower jaw was broken through the body on both sides, as well as at the symphysis. The left clavicle, the second, third, and fourth left ribs anteriorly, the fourth and fifth posteriorly also, and the fourth right rib anteriorly and posteriorly, were fractured. Reduction of the fractures of the facial bones was effected; but the child died from the chest-injuries in about thirty hours.

FIG. 11.



Results of a case of multiple fractures of the bones of the face. (Agnew.)

Cases are upon record in which children have been run over or otherwise subjected to great violence, and the ribs have given way; but in almost every instance such other damage has been done as to prevent recovery. Thus, Fayer<sup>3</sup> mentions the case of an East Indian boy, aged two, who had fracture of the left fifth and sixth ribs, with hæmoptysis, and died from exhaustion in a few hours. No details are given, but it may be assumed that the lung was wounded. Rupture of the lung has been repeatedly seen where the ribs, from their elasticity, have escaped fracture.

On the books of the Children's Hospital in this city there is noted in 1874 the case of a boy, aged five, who was caught under a falling pile of lumber and had two ribs broken on the right side. Some emphysema ensued, but adhesive strips were applied, and the boy went out cured on the sixteenth day. Another boy, aged eight, was admitted in 1875, having had the fifth right rib broken by the passage of a wagon-wheel; he was discharged cured on the twenty-fifth day. Coulon records the case of a child who died from rupture of the lung, and who was found to have sustained partial fracture of two or three ribs on each side.

<sup>1</sup> Deutsche Zeitschrift für Chirurgie, 1877, p. 106.

<sup>2</sup> Clinical and Pathological Observations in India, p. 223.

The symptoms of fracture of the ribs are pain, difficulty of breathing, crepitus, and perhaps emphysema. Ecchymosis may be present, and together with the history of the accident will help to indicate the seat of the lesion.

Adhesive strips of suitable width should be firmly applied over the whole of the affected side, so as to control the movements of the chest-walls. Other treatment should be instituted according to circumstances.

**Fractures of the pelvis** are of extreme rarity in early life. I have seen one in a boy of sixteen, who had fallen from a height; the exact seat of fracture could not be determined, but it was in the anterior portion; the urine had to be drawn off for four days; recovery was complete.

Bryant mentions an extraordinary case: "in a female child, great separation of the pelvic bones was present, the whole pelvic organs having been pressed out of the outlet of the pelvis by the crushing force. The large intestine for about a foot, uterus, bladder, etc., were all in view, the whole perineum having been ruptured." Complete recovery ensued, although, of course, with permanent damage to the parts.

In another case, that of a boy aged seven, Bryant says, there were "fracture of the pubic bones and laceration of the urethra, accompanied with profuse hemorrhage and retention, for which catheterism was ineffectual, and death seemed imminent." Free incision of the perineum down to the urethra gave relief, and the boy recovered rapidly.

A great deal of shock must follow an injury of this kind, and will demand attention; a wide bandage should be placed about the pelvis, and care taken, if necessary, to draw off the urine as it collects in the bladder. Other symptoms must be met as they arise.

**FRACTURES OF THE BONES OF THE UPPER EXTREMITY.**—**Fractures of the clavicle** are very common in children, and may be due to either direct or indirect violence; in the latter case the line of breakage is generally oblique from behind forward and from within outward. In the majority of cases the middle third of the bone is the part affected.

Gross<sup>1</sup> says that he has twice met with intra-uterine fracture of this bone, from violence applied to the mother's abdomen; and Gurlt gives seven instances of the kind. I myself saw such a case in 1859 with the late Dr. W. Keller, of this city.

Gibson<sup>2</sup> mentions having seen the clavicle broken during birth from an ignorant midwife pulling at the arm.

The clavicle is said to have given way to muscular action in convulsions, in the case of a boy of ten, quoted by Gurlt from Streubel, and to a violent effort at bowling in a boy of fourteen, as reported by Heath.<sup>3</sup>

Sometimes the fracture is incomplete. Malgaigne gives one case of his

<sup>1</sup> Surgery, vol. i. p. 944.

<sup>2</sup> Surgery, vol. i. p. 255.

<sup>3</sup> British Medical Journal, November 18, 1882.



own, and quotes several others.<sup>1</sup> Holmes<sup>2</sup> gives an excellent representation of a specimen.

On the other hand, Malgaigne mentions a little girl, the subject of "a double fracture, in which the middle fragment, about two centimetres in length, was situated vertically between the two others," and could not be disengaged.

When the violence producing the fracture has not been very great, the periosteum may be untoru, and the fragments are held closely together. Yet the finger carried along the bone will detect the break, and pain will be caused by pressure at this point. And in a day or two there will be notable swelling from the deposit of callus; it seems also as if the periosteum became softened, and yielded.

When there is displacement, it is due chiefly, as in the adult, to the action of the serratus magnus muscle, rocking the scapula around forward, and through the acromion process pushing the outer fragment of the clavicle inward; the pectoralis minor will act in the same way.

As a general rule, to these symptoms, pain and perceptible deformity, there is added loss of power in the arm and hand, with more or less distinct crepitus. The child refrains from play, supports the arm of the injured side with the opposite hand, and very often inclines the head toward the damaged shoulder, so as to avoid muscular tension.

Very often the union of a broken collar-bone takes place with great readiness. Berry<sup>3</sup> says that in six cases, of ages ranging between five months and five years, the consolidation was found complete in from nine to fourteen days, the longest time being noted in the youngest child.

I have recently seen a girl five months old with a fracture of the clavicle caused, her mother said, by falling out of bed; crepitus was distinctly felt, but could not be precisely located, by reason of the plumpness of the parts. Union was perfect in seven days.

Non-union sometimes, however, occurs. I saw in 1857 a girl aged ten who three months before had fallen headforemost about fifteen feet upon some sand. She had an ununited fracture of the left clavicle, about one inch from its acromial end; the inner fragment was tilted backward, the outer one upward; movement of the head toward the left side was difficult. A case is mentioned<sup>4</sup> of "a girl aged nine who had broken her clavicle a month before, and had had no treatment; the sternal fragment projected upward at an angle of forty-five degrees, its sharp extremity forming a visible prominence at the side of the neck. The other fragment was fully an inch below this, and connected with it by what appeared to be a band of

<sup>1</sup> See also Blandin, *American Journal of the Medical Sciences*, April, 1843, from *Journal de Méd. et de Chir. prat.*, Juillet, 1842; and Robert, *ibid.*, January, 1859, from *L'Union Médicale*.

<sup>2</sup> *Surgical Treatment of the Diseases of Infancy and Childhood*, 1868.

<sup>3</sup> *New England Medical Monthly*, March 15, 1883.

<sup>4</sup> *Holmes's System of Surgery*, 3d ed., vol. i. p. 948; American edition, vol. i. p. 846.

fibrous tissue passing nearly vertically between them." Pollard<sup>1</sup> resorted successfully to resection and wiring in the case of a child aged sixteen and a half months, the fracture having occurred five and a half months previously. Barker<sup>2</sup> reports another instance, in a boy aged twelve, who had, in addition to non-union, troublesome nerve-disturbances.

Fracture of both clavicles is rarely seen in children. Bennett<sup>3</sup> saw a case in a girl aged six, run over by a car; the fracture on one side was incomplete. Her other injuries proved fatal. Lonsdale speaks of a fracture of the collar-bone about half an inch from the sternum, in a boy aged three, who fell against a step; and says, "the other clavicle had been broken about a fortnight previously."

Holmes<sup>4</sup> says that he has seen a death from laceration of the internal jugular vein by one of the fragments of a broken clavicle in a child. In this case the fracture was of both bones. Such complications are infrequent; but Gross<sup>5</sup> saw a boy aged fifteen who four months previously had had a fracture of the right collar-bone by the recoil of a gun; "partial paralysis of the superior extremity, with atrophy and permanent contraction of some of the muscles of the arm, forearm, and hand," had resulted.

The *treatment* of these fractures has received much attention from surgical writers, and very many forms of apparatus have from time to time been proposed. I venture to assert, however, that the principle really involved is extremely simple; that the action of the serratus magnus and pectoralis minor must be opposed, and the scapula pushed round toward the median line of the back. When this is effectively done, the outer fragment of the clavicle is drawn into proper position, and the deformity disappears.

No pad should be placed in the axilla. I lay special stress on this, because the axillary pad, intended to force the shoulder outward and upward, was a chief feature in the apparatuses invented and advocated by Fox, Levis, Hamilton, and one or two others. But not only is it entirely inefficient; its pressure may do serious harm. A case is reported<sup>6</sup> in which a girl of eight years, having broken her clavicle, was attended by a surgeon who applied a pad in the axilla, bandaged the arm from the fingers up, and then bound the arm to the side; gangrene ensued, and amputation became necessary; a lawsuit followed, and it was held that the pressure against the pad had checked the circulation.

Sayre's method seems to me to fulfil the indications better than any other, for children as well as for adults. It consists of two strips of good adhesive plaster, of length and width proportioned to the size of the patient.

---

<sup>1</sup> British Medical Journal, March 26, 1887.

<sup>2</sup> Ibid., January 30, 1886.

<sup>3</sup> Medical Press and Circular, January 5, 1887.

<sup>4</sup> Surgical Treatment of the Diseases of Infancy and Childhood, 1868, p. 248.

<sup>5</sup> Op. cit., vol. i. p. 946.

<sup>6</sup> British Medical Journal, May 29, 1886.

One of these is carried round the upper part of the arm, thence across the back and round the thorax; it draws the head of the humerus backward toward the median line, and thus crowds the scapula in the desired direction, the acromion carrying with it the outer fragment of the clavicle. The hand is now brought up toward the sound shoulder, and the second strip placed diagonally around the elbow and shoulder, one portion going in front and the other behind.

In most cases the inner fragment needs no attention. Occasionally, however, it has been forced forward by the outer fragment getting behind it; and then gentle pressure by means of a pad of suitable size, kept in place by small strips, may be employed to push it back into its proper position.

Compound fracture of the clavicle is of extremely rare occurrence in early life. In one case, reported by Whitson,<sup>1</sup> the bone was sutured, with a good result.

Schneck<sup>2</sup> had occasion to treat a little girl aged five who had been kicked by a colt, and who had a fracture of the clavicle complicated with fracture of the upper part of the humerus. Fox's apparatus was used for the former, and a hollowed wooden splint for the latter, the arm being confined to the side, with a perfect result in each. Foulerton<sup>3</sup> met with a case in which a boy nineteen months old, whose nurse pulled him by the hand, had a fracture of the clavicle and a separation of the upper epiphysis of the radius.

**Fractures of the scapula** are very rarely met with in children. I have myself seen one, in a little girl two and a half years old, who had fallen down three steps; the neck of the bone was broken. Another case of the same kind has been reported by Dr. John Ashhurst:<sup>4</sup> in both the diagnosis was made by exclusion. Gurlt quotes from Michon a case in which a child, in getting up off the ground, fractured the scapula by muscular action. I have lately had in the Pennsylvania Hospital a boy said to be two years old, but very large for that age, who fell out of a third-story window, sustaining a fracture in the shoulder-joint, probably through the glenoid cavity; crepitus was very distinct, but could not be accurately located. On the sixteenth day all trace of the injury had disappeared.

By reason of the relations of this bone, there is very little tendency to displacement when it is broken. The treatment consists in keeping the whole shoulder and arm at complete rest,—which can be done by a cap of binder's board or thick pasteboard moulded to the part, and a bandage confining the arm to the side. A carefully-applied plaster dressing would answer the same purpose.

**Fractures of the humerus** are very often met with in children; they

<sup>1</sup> British Medical Journal, January 6, 1883.

<sup>2</sup> American Journal of the Medical Sciences, April, 1858.

<sup>3</sup> Lancet, October 2, 1886.

<sup>4</sup> Transactions of the College of Physicians of Philadelphia, 1875, 3d series, vol. i.

may result from direct or indirect violence, or from muscular action. Any portion of the bone may give way, but in by far the largest number of cases the lower third suffers. (In adults the reverse is true, the upper portion being in them much more frequently broken.)

The *anatomical neck* of the humerus is reported by Fraser<sup>1</sup> to have been fractured by machinery, in a boy aged fifteen, the head of the bone being displaced downward; reduction of both fracture and luxation was effected under chloroform, and "perfect recovery" ensued.

But in the majority of instances in early life the *upper epiphysis* is detached, when in an adult the anatomical neck would give way. Such an accident, according to Chapelain-Durocher, has occurred during birth, from the midwife hooking her finger into the axilla and making traction. Bruns<sup>2</sup> collected six instances of this kind.

Hamilton mentions a case in which a child thirteen months old fell from his cradle and was said by an empiric to have sprained his shoulder. Three weeks afterward Dr. H. was called in, and detected a separation of the epiphysis, which he treated; but no union had taken place five months later.

Esmarch<sup>3</sup> excised the separated epiphysis in a child aged five on account of osteo-myelitis and suppurative arthritis of the shoulder.

Fuqua<sup>4</sup> reports the case of a boy aged ten who made a perfect recovery from what was supposed to be a disjunction of the upper epiphysis of the humerus, caused by a fall from a horse. There may be some doubt about the diagnosis in this case.

Richmond<sup>5</sup> reports two instances: one that of a girl aged ten, injured by falling down three or four feet on her back, and treated with a moulded leather cap over the shoulder; the other that of a young man aged nineteen, treated by first raising the arm, then bringing it down and applying extension and counter-extension by means of an outside splint. In the former case there was some deformity remaining; in the latter "a perfect result" was obtained.

Hamilton mentions two cases, in boys aged thirteen and sixteen, in which the injury was supposed at first to be luxation, and treated as such. Some shortening ensued in both; the ultimate result in the younger was unknown, but the other had a perfectly useful arm.

A remarkable case is mentioned by Bouchut as observed by Foucher. A girl aged thirteen was taking a frame down from a wall above her head, when the upper epiphysis of the humerus was separated by the muscular effort she made; an abscess formed, and death ensued in about seven weeks, when the diagnosis was established by an autopsy.

---

<sup>1</sup> American Journal of the Medical Sciences, April, 1869.

<sup>2</sup> Archiv für Klinische Chirurgie, 1882, Bd. xxvii.

<sup>3</sup> Waitz, Langenbeck's Archiv, 1877, Bd. xxi.

<sup>4</sup> Louisville Medical Herald, January, 1882.

<sup>5</sup> New York Medical Journal, November, 1877.

Sometimes these separations are compound. Knox<sup>1</sup> reports such a case in a boy aged sixteen, whose horse fell on him; the end of the shaft of the humerus protruded through the deltoid muscle. Reduction was effected, and the wound dressed antiseptically; a shoulder-cap of felt and an inside angular zinc splint were applied, and the boy made a perfect recovery.

Clark,<sup>2</sup> in a similar case caused by a machinery accident, was obliged to amputate, the limb becoming gangrenous by reason of damage to the axillary artery. He refers to sixteen instances in which this lesion was simple, and to four in which it was compound; two of the latter ended fatally.

Separation of this epiphysis had been recognized by Sir A. Cooper,<sup>3</sup> and by Sir C. Bell, who says,<sup>4</sup> "I have known it occur from a boy firing a musket;" but it was first accurately described by R. W. Smith, of Dublin, in 1847. An important fact, pointed out by Mr. Jonathan Hutchinson<sup>5</sup> and myself,<sup>6</sup> is the rotation inward of the upper fragment by the action of the supraspinatus, infraspinatus, and subscapularis muscles. This idea was again brought forward by Dr. E. M. Moore, in a paper read before the American Medical Association in 1874, with the suggestion that the end of the shaft became caught in the concavity of the lower surface of the epiphysial fragment; he proposed carrying the arm upward and forward to the perpendicular (median?) line, and then making extension. I would venture to express my belief that a better plan is to follow the upper fragment with the lower, first by extension overcoming any impaction that may exist, and then carrying the elbow upward and outward so that the arm shall be at an angle of perhaps forty-five degrees with the body, in which position it can be readily supported by means of a splint, one branch of which should be applied to the side of the chest, the other to the inner side of the arm. After a week or two the splint may be changed so as to lessen the angle, and again two or three days later, and so on until the arm is brought down close to the body.

Helfferich<sup>7</sup> presented to the Society of German Surgeons a successful case in which he had cut down upon the fragments, reduced the displacement, and fastened the pieces together with a long steel pin, which was left in place for a fortnight. Bruns reported two cases, and Woelfler one, in each of which excision of the epiphysial fragment had been resorted to. Such operations, it seems to me, must be rarely called for.

Bruns (*loc. cit.*) refers to two cases in which this injury, unrelieved, was followed by serious interference with the development of the bone. In one

---

<sup>1</sup> Medical News, December 5, 1885.

<sup>2</sup> Glasgow Medical Journal, September, 1886.

<sup>3</sup> Dislocations and Fractures, etc., p. 431.

<sup>4</sup> Institutes of Surgery, 1838, vol. i. p. 110.

<sup>5</sup> Medical Times and Gazette, March 10, 1866.

<sup>6</sup> New York Medical Journal, October, 1866.

<sup>7</sup> Annual of the Universal Medical Sciences, 1889, from *La Semaine Médicale*, April 11, 1888.

a man aged twenty had had at ten years of age a separation of the epiphysis, and the arm was shortened by thirteen centimetres; in the other, a man aged forty-nine, who in his second year had "hurt his shoulder," the shortening amounted to fourteen centimetres. Bryant mentions having seen a woman aged thirty whose arm was shortened five inches, from injury to the upper epiphysis of the humerus in early infancy. Shearer<sup>1</sup> saw a man aged fifty-three whose arm was shortened by four inches, as the result of a fracture near the head of the humerus, sustained at two years of age; this was probably a similar case. It is not too much to assert that accurate apposition of the fragments will be the surest means of preventing such trophic changes.

*Fractures of the surgical neck of the humerus* are not common in early life, although they may, of course, occur as the result of direct violence. Their main interest consists in the difficulty of maintaining apposition, on account of the action of the muscles; the lower fragment is usually strongly drawn upward and inward, while the upper one is tilted over, so that the two form an angle salient outward.

Hutchinson (*loc. cit.*) says he saw a boy aged ten with fracture below the tuberosities, in whom the lower fragment was outside of and behind the upper, and was held there so firmly by bands of periosteum that reduction was impossible, even on the post-mortem table.

A boy six years old was brought to the Pennsylvania Hospital about two months since, having been struck by a locomotive and thrown about twenty feet into a ditch. He had a compound fracture of the surgical neck of the right humerus, and a simple fracture of the outer third of the clavicle. Two weeks later there was evidence of suppuration in the shoulder-joint, and excision was thought of, but a sudden improvement occurred, and all the symptoms subsided. He has now only a slight stiffness remaining in the joint.

Hamilton mentions two cases, in boys aged respectively twelve and fifteen, in both of which there was permanent shortening and deformity, but not loss of mobility or strength.

A less favorable result attended a case reported by Vogt;<sup>2</sup> it was that of a girl aged eleven, in whom, although there was an excess of callus, union failed to occur, and there was loss of sensation and of usefulness in the limb; excision of the upper fragment was resorted to, and electricity, but with no marked benefit, by reason, it is said, of neglect on the part of the parents of the child.

*Fractures of the shaft of the humerus* are not infrequent in children; they have resulted sometimes from obstetric operations, and occasionally from the compression caused by the contractions of the womb.

Powell<sup>3</sup> saw in a child four days old a fracture at the middle of the

<sup>1</sup> British Medical Journal, October 10, 1885.

<sup>2</sup> Deutsche Zeitschrift für Chirurgie, 1877.

<sup>3</sup> Medical Bulletin, January, 1884.

humerus, caused by rough handling on the part of a nurse. Prewitt<sup>1</sup> was called to a female child six days old who had a fracture of the humerus at the junction of the middle and upper thirds, said to have been caused three days before by the mother lifting her; there was some doubt whether the injury had not occurred during birth.

Campbell<sup>2</sup> reports the case of a boy sixteen days old who fractured the humerus near the middle by falling out of bed; good union took place in three weeks. The treatment is stated to have been by means of a gutta-percha splint, with a pad on the inner side of the arm, the limb being bound to the chest with adhesive plaster and bandages.

In older children blows, falls, and violence of various kinds produce these injuries. Sometimes, but rarely, they are compound; I have had to amputate the arm of a boy only seventeen months old for railroad crush, and he completely recovered. In a number of instances, in early life, the humerus has given way under muscular effort in throwing. Bellamy<sup>3</sup> records one at the age of fourteen; Perrin<sup>4</sup> one in which the same boy twice broke his humerus in the lower third in this way, a year's time intervening between the two accidents.

Occasionally in these cases the periosteum is untorn, and holds the fragments together; but there is pain, helplessness of the limb, and tenderness on pressure. Usually, however, the mobility at the seat of fracture makes the diagnosis clear. One of my own children, at the age of six, had his humerus broken in the lower third, by direct violence; but it was not until two weeks later, when he had a fall, that the fragments were disjoined. Raleigh<sup>5</sup> reported a similar case in a boy aged nine years.

Complications of these fractures are not often met with in children; but Laurent<sup>6</sup> gives a case related to him by Richet, in which a boy aged ten fell off an ass, and broke the humerus at the middle; next day a small pulsating tumor was noted, evidently an aneurism caused by wound of the artery by one of the fragments. Ligation above and below was practised, with a good result. Stamford<sup>7</sup> is reported to have shown to the Sheffield Medico-Chirurgical Society a girl twenty-one years of age with atrophy of the deltoid, supraspinatus and infraspinatus, biceps, and brachialis anticus, supposed to be due to "a green-stick fracture of the humerus over nineteen years previously."

The treatment of fractures of the humerus has varied greatly in different hands. I shall only mention that which I have always found effective. A splint of light wood, of sheet zinc, or of binder's board should be adapted

---

<sup>1</sup> St. Louis Courier of Medicine, November, 1881.

<sup>2</sup> New York Journal of Medicine, May, 1858.

<sup>3</sup> Lancet, May 11, 1878.

<sup>4</sup> L'Union Médicale, June 9, 1857.

<sup>5</sup> American Journal of the Medical Sciences, February, 1836.

<sup>6</sup> Des Anévrysmes compliquant les Fractures, p. 42.

<sup>7</sup> Lancet, May 25, 1889.

to the inner side of the arm, the elbow being flexed at a right angle; this splint should extend from well up in the axilla to the ends of the fingers, the upper end of it being rounded off. Three small splints of zinc or binder's board should next be cut out, one for the back of the arm from the shoulder to the elbow, one for the outer side, and one for the front. Each of these is now to be carefully padded with an even layer of clean, raw cotton, or with two to four layers of canton flannel. Just at the elbow, in the inside splint, a hole should be cut for the epitrochlea or inner condyle, or else a pad should be placed just above, so as to prevent pressure on that bony prominence. Reduction being now carefully accomplished, the splints are applied, and secured by a roller bandage, beginning at the fingers and ending at the shoulder. The turns should be put on as accurately as possible, just tightly enough to keep the entire limb at perfect rest. The whole is now suspended from the neck by means of a sling.

When the fracture is above the middle of the bone, it may be well to substitute for the three small splints a pasteboard cap, accurately cut out, softened, and fitted so as to extend from the tip of the shoulder to the elbow, embracing a little less than two-thirds of the circumference of the arm. Between this and the inside splint, I have never found it difficult to control the fragments.

Cases of delay or failure in union are more frequent in this bone than in any other part of the skeleton. Mott<sup>1</sup> reported an instance in which a boy of twelve had a fracture which after the lapse of eight months had not united, the ends of the fragments having become conical; setons were twice used, but failed; the ends were then cut down upon and sawn off, and the surfaces of bone wired together, with excellent success.

White is credited with the first resection in a case of this kind, in 1759; but he says<sup>2</sup> he was not the operator; the result was perfect.

A very curious case has been recorded by Clarke,<sup>3</sup> of a fast-growing boy who had a fracture of the arm, which united; he returned to school, overworked himself in trying for a prize, and broke down in health, when the fragments were found to have become disjoined.

In the Warren Museum<sup>4</sup> there is a specimen (No. 1314), from a boy fifteen years old, of the lower six and a half inches of the humerus, necrosed after fracture of the bone and compound dislocation of the elbow. After the removal of the sequestrum, healing took place, and "when heard from four or five years afterwards, he had a good arm, and sufficient motion at the elbow."

*Fractures of the Lower Portion of the Humerus.*—Close above the elbow, where the humerus widens out, becoming thinned antero-posteriorly, frac-

<sup>1</sup> Transactions of the New York Academy of Medicine, 1857, vol. i.

<sup>2</sup> Cases in Surgery, p. 69.

<sup>3</sup> Medical Times and Gazette, November 16, 1867.

<sup>4</sup> Catalogue, pp. 243-44.



ture very often occurs in children, and is apt to be followed by permanent disability.

The short lower fragment is tilted forward by the action of the flexors, pronators, and extensors, aided by the upward pull of the triceps, the biceps, and the brachialis anticus upon the radius and ulna. Hence there is formed between the two fragments an angle salient forward; and unless this is corrected it will be found, when union has taken place, that flexion of the elbow is limited, for an obvious reason. (See diagram, Fig. 12.) Of this I have myself witnessed repeated instances. A clear description of this state of things, with an illustrative case, in a boy aged eight years, is given by Coulon.<sup>1</sup>

FIG. 12.

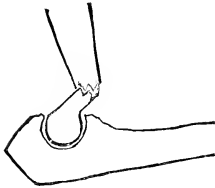

Verneuil, in a discussion at the Société de Chirurgie<sup>2</sup> in Paris, mentioned a boy aged twelve who by a fall from a horse had the humerus broken at its lower part. There was good union without deformity, but the radial nerve was paralyzed. Four months later the arm and forearm were shrunk, and the lower fragment was almost doubled in its antero-posterior diameter. The elbow had been kept immovable for seventy days. Extension was possible to one hundred and thirty degrees, flexion only to ninety degrees. Pronation and supination were free.

From luxation of the elbow backward, which it much resembles, this injury may be distinguished by three points. First, there is apt to be distinct crepitus, easily perceived. Secondly, there is abnormal mobility in every direction; on grasping the arm with one hand and the forearm with the other, the surgeon will find not only flexion and extension free, but the forearm movable also from side to side. Thirdly, the olecranon will be found to preserve its normal relation to the epitrochlea and epicondyle.

I have in one instance seen this fracture compound, in a boy about twelve years old, who had fallen from a low fence; the artery was torn across, and I was obliged to amputate.

Lange has recorded<sup>3</sup> the case of a girl aged eight, who after a fracture close to the lower end of the humerus had pain at the seat of injury, the wrist and fingers being flexed, with a very limited degree of motion. A sharp edge of bone could be felt. An incision was made, and the median nerve found flattened against the edge of bone; above this point the nerve was thickened. The nerve was loosened, and the edge of bone excised, with decided relief. A curious point is that in this case the growth of the nails was interfered with previous to the operation.

Various plans have been recommended for the treatment of these cases;

<sup>1</sup> Op. cit., p. 136.

<sup>2</sup> Bull. et Mém., 1880.

<sup>3</sup> New York Medical Journal, April 28, 1883.

but I shall mention only one, devised by me many years ago, which meets the indications, and which has given me the best results. Measuring by the sound limb, I cut out a piece of binder's board, or in a very young child a piece of pasteboard, in the shape shown in the diagram (Fig. 13). This is then again cut in the dotted lines, and it will be seen that *a* can be turned over so as to fit along the front of the arm, while *b* will be on its inner side, and *c* on that of the forearm. The portions *e, e, e, e*, turned up, will steady the forearm and hand, while *d* is turned up so as to push forward the olecranon and with it the lower end of the lower humeral fragment.

FIG. 13.

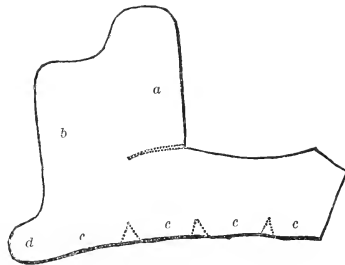

Properly padded, this splint is secured by means of a bandage accurately applied from the fingers to the shoulder, and the hand and forearm are supported by a sling.

My own practice is, in this as in all other fractures near joints, to begin very early with passive motion. Thus, a week after the injury I very firmly grasp the limb at the seat of fracture, and gently flex and extend the joint through a small arc, avoiding the infliction of any pain. The joint has not yet stiffened, and the fracture can be controlled. At every dressing this manœuvre is repeated, through a larger and larger range.

I think it is well also, at the end of fourteen to sixteen days, to cut away the hand part of the splint, and let the little patient begin to move the fingers. A week later, the whole hand can be left free; and by the time the splint is removed, the limb will be almost restored to usefulness.

No prudent surgeon will forget, in dealing with a fracture of this kind, that there is danger of gangrene from interference with the circulation in the brachial artery. Sometimes this has been unavoidable, the vessel having been pressed upon by the end of the upper fragment; but an ill-adjusted splint, or a bandage too tightly applied, may increase the evil, and, no doubt, has in some instances given rise to it.

Malgaigne mentions a remarkable case seen by him; it was that of a little girl two years old, in whom a fracture just above the lower end of the humerus, sustained several months before, had wholly failed to unite.

*Separation of the lower epiphysis of the humerus*, although much like the injury last mentioned, differs from it in the absence of any peculiar tendency to displacement. Farabœuf<sup>1</sup> has discussed the anatomy of this lesion, which he thinks must be very rare after the age of four years. At birth the whole of the lower end of the bone is cartilaginous, and ossification begins first in the condyle at the end of the second year.

<sup>1</sup> Bull. et Mém. de la Société de Chirurgie, 1886, vol. xii.

According to Gray, the lower epiphysis of the humerus is developed as follows: "At the end of the second year, ossification commences in the radial portion of the articular surface, and from this point extends inward, so as to form the chief part of the articular end of the bone, the centre for the inner part of the articular surface not appearing until about the age of twelve. Ossification commences in the internal condyle [epitrochlea] about the fifth year, and in the external one [epicondyle] not until between the thirteenth and fourteenth years. About the sixteenth or seventeenth year, the outer condyle [epicondyle] and both portions of the articulating surface, having already joined, unite with the shaft; at eighteen years, the inner condyle [epitrochlea] becomes joined."

My belief is that in young children the leverage exerted through the ulna sometimes twists off the whole or a portion of the epiphysis; for I have repeatedly observed, in subjects less than five or six years old, injuries of the elbow in which there was crepitus, and yet no traceable line of fracture; a certain looseness of the joint, and helplessness of the limb, which have seemed to me to admit of no other explanation. These cases have always done well with very simple treatment,—an angular splint for the front or inner side of the arm, with early and thorough, though very gentle, passive motion. Wight<sup>1</sup> met with a curious combination of injuries in a boy aged eight, who fell from a cart and sustained a fracture of both bones of the forearm less than an inch (two centimetres) from the wrist, together with separation of the lower epiphysis of the humerus. Passive motion of both joints was begun on the third day, and good union was obtained, although at the time of the report the movements of the elbow were still somewhat hindered by excessive deposit of callus.

Maisonneuve<sup>2</sup> met with a compound separation of the lower epiphysis of the humerus, the shaft projecting some distance through a large wound. The patient, a boy aged seven, had fallen about ten feet. Reduction was effected with some difficulty; in three months the wound healed, and a complete recovery ensued, but not before eighteen months had elapsed.

Among English and American writers there is a somewhat awkward confusion of terms in regard to the lower extremity of the humerus. The term "condyles" has been applied by anatomists to the tuberosities at the outer and inner sides, and has been so used also by surgeons, who have, however, often included in it the adjoining portion of the articular surface. Indeed, the whole of the trochlea has been sometimes spoken of as part of the inner condyle, and the rest of the joint-surface as belonging to the outer; while fissures running down into the joint have been termed "intercondylar." Such confusion may be avoided by adopting the French nomenclature, and speaking of the trochlea and epitrochlea, the condyle and the epicondyle.

*Fractures of the epicondyle* have been observed in children. A typical

<sup>1</sup> Annals of Anatomy and Surgery, October, 1880.

<sup>2</sup> Clinique Chirurgicale, tome i. p. 533.

case of this injury is recorded by Coulon,<sup>1</sup> in which a boy aged three and a half years fell from a chair to the ground; the broken piece, very small, was distinctly felt. The arm was simply kept on a pillow, and compresses soaked in tincture of arnica applied; consolidation had taken place on the twelfth day, and all the movements of the elbow-joint were perfect. But in many cases, although there is detachment of the epicondyle, this is only a portion of the injury, the elbow being dislocated, or the joint-surface being also involved. Coulon reports two other instances of what he calls intra-articular fractures of the epicondyle, one in a boy six years old, another in a boy of fourteen; both these cases resulted in serious deformity and disability, and should be classed with fractures of the elbow.

*Fractures of the epitrochlea* are much more common. Coulon gives three instances, two in boys aged ten and a half and eleven respectively, and one in a girl aged three and a half. In all, the injury was readily recognized, and the movements of the joint were completely restored, or almost so, in a short time. The same may be said of a boy aged eleven seen by Hamilton, as well as of a girl aged thirteen, and a boy aged eleven, mentioned by Stimson.

The fragment in such a case may be displaced either upward or downward (toward the wrist). Sometimes it remains loose. As the flexors and pronators take their origin partly from the epitrochlea, the lesion may sometimes at least be in the nature of a sprain-fracture, the fragment being torn away; and the same fact may explain the displacement in some cases. Occasionally, perhaps, the piece may be pulled away by stress on the internal lateral ligament.

When the articulation is invaded, as in what Coulon calls intra-articular fracture of the epitrochlea, the results are very grave. In four instances cited by him the loss of motion in the joint was such as greatly to impair the usefulness of the limbs. Granger<sup>2</sup> first described this injury, giving an account of two cases, both due to falls on the hand. One of the patients, a boy aged eleven, had also a luxation of the elbow, which was reduced; but, by reason of neglect, he failed to recover flexion and extension in the joint. In the other case, that of a boy aged eight, the fragment was retracted below the joint; there was such irritation of the ulnar nerve that the muscles supplied by it were paralyzed, and crops of vesicles appeared in the skin in that region; the use of the hand was, however, ultimately regained.

It seems to me that in both these instances, certainly in the first one, the fracture must have entered the joint; and if a portion of the trochlea is broken off, the occurrence of luxation of the forearm backward, or backward and inward, is greatly favored. Among the recorded cases I find but one, quoted by Gurlt from Senffleben, in which the result is said to have been good; it was that of a boy aged eleven. Gurlt cites from Langenbeck the history of a boy aged ten, whose elbow was ankylosed; on resection the

---

<sup>1</sup> Op. cit., p. 143.

<sup>2</sup> Edinburgh Medical and Surgical Journal, April, 1818.

broken condyle (trochlea?) was found in the olecranon fossa; death ensued from pyæmia. The same surgeon has reported the case of a boy aged seven, in whom the luxation was reduced, but the joint was permanently stiffened. In the Warren Museum<sup>1</sup> there is a specimen from a girl aged sixteen, who had a fracture of the inner condyle (trochlea?) with dislocation backward and outward of the elbow. Sloughing ensued, and amputation was performed on the forty-sixth day; "the condyle is seen to have undergone considerable change, as have also the other bones, more or less."

Let it be noted that the same muscular violence which is charged in some instances with tearing off the epitrochlea would also, through the ulna, be very apt to wrench away a portion of the trochlea itself.

The symptoms of fracture of the trochlea need hardly be discussed in detail; they are, indeed, often masked by the swelling which so rapidly ensues upon the receipt of the injury.

As to the treatment, it must be directed first of all to the allaying of inflammation in the joint; I think free leeching, with the employment of evaporating lotions for a few days, highly advisable. On the subsidence of the swelling, the deformity should be carefully corrected, and the limb placed at rest with the elbow well flexed. Passive motion should be begun early, and carried out thoroughly but very gently every day. This seems to me of more importance than anything else. I myself employ the splint shown in Fig. 13 (p. 1069); if an anterior angular splint is preferred, a short posterior splint applied from the middle of the upper arm down to the point of the elbow may be added, in order to press the olecranon, and with it the fragment, forward.

*Fractures of the condyle* are by no means uncommon in children. Hamilton (1880) says that of twenty-nine cases recorded by him, twenty-seven were in patients under fifteen years of age.

Direct violence may give rise to this injury; or, if the hand is fixed with the elbow in flexion, and a blow is received low down on the back of the arm, the condyle may be forced off by the head of the radius.

In a case shown by Bidwell<sup>2</sup> to the Hunterian Society, a boy aged five had had a fall on the hand thirteen weeks previously. He was said to have dislocated the elbow, and splints were applied for three weeks. When shown, there was deformity, widening of the elbow, and very little motion; the outer half of the articular extremity of the humerus, displaced forward and outward, was firmly united. It seemed obvious that the condyle had been forced off by the upward thrust of the radius. Excision of the joint was proposed.

Compared with fracture of the trochlea, that of the condyle is much less serious, since it does not affect the portion of the joint which is essential to its stability. The fragment, and with it the head of the radius, is apt to be displaced backward, or backward and outward. Usually it can be easily replaced, but often there is difficulty in retaining it.

<sup>1</sup> Catalogue, p. 172.

<sup>2</sup> Lancet, May 4, 1889.

The diagnosis may be made by exclusion, but is rendered certain if the fragment can be grasped and moved upon the rest of the bone.

As to treatment, the elbow may be flexed and the hand supinated, and an anterior or a posterior angular splint applied. Early and frequent passive motion should be made. Even if union fails to occur, the strength and functions of the limb are not likely to be seriously and permanently impaired.

In a case recorded by Wright,<sup>1</sup> a strumous boy aged twelve had a fracture detaching the condyle, upon which there ensued a pulpy degeneration of the joint, demanding excision.

One point should never be overlooked in any case of fracture at the lower portion of the humerus, but especially in separations of the trochlea: there is apt to be caused a change in the relation of the arm with the forearm, which seriously impairs not only the shape but also the usefulness of the limb. Normally, if the elbow is extended with the hand in supination, the forearm forms with the arm an obtuse angle salient inward, toward the median line of the body; and the fold of the elbow in front curves obliquely downward and inward. (Fig. 14.) The reason of this is the obliquity of the trochlea. If now a splint is applied which presses straight across, it pushes up the lower and more movable fragment, and the result is that the forearm either comes into a straight line with the arm, or even makes with it an angle salient outward. Union taking place under such circumstances, as pointed out long ago by Dorsey,<sup>2</sup> and later very forcibly by Allis,<sup>3</sup> there will be at all times a very notable awkwardness in the limb, besides marked interference with its strength and usefulness in many of its functions.

In order to obviate this difficulty, Allis and others have proposed treating these fractures with the limb in the straight position. I think a better plan is to make a splint which shall conform to the normal shape of the joint, and to keep the hand away from the body. This is not always easy to do; and, indeed, one may often see these fractures dressed not only with the hand in supination, but with the forearm carefully drawn forward and slung as close to the front of the body as possible. Fig. 15 shows a splint of a shape such as I have often used with satisfaction; it can be made of wood, of tin or zinc, of binder's board, or of wire netting.

FIG. 14.



Normal relation of arm and forearm in extension and supination.

FIG. 15.

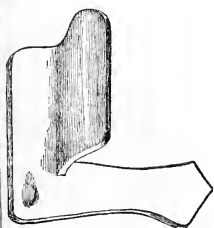

<sup>1</sup> Guy's Hospital Reports, 1879, 3d series, vol. xxiv.

<sup>2</sup> Elements of Surgery, vol. i. p. 145; also Plate V.

<sup>3</sup> Annals of the Brooklyn Anatomical and Surgical Society, August, 1880.

The opinions of surgeons have varied greatly in regard to the treatment of fractures about the elbow. Desprès<sup>1</sup> has advocated the use of a simple sling, with poultices; but was strongly opposed by Sée, Verneuil, and Lannelongue, who thought the immovable apparatus should always be employed. Sée mentioned the case of a child treated without splints, with a very bad result, the elbow being ankylosed and greatly deformed. Verneuil and Lannelongue thought there was great risk of hyperostosis under any treatment.

Hllingworth<sup>2</sup> has recommended the employment in these injuries of a "box-splint," the limb being placed in extension, with the hand pronated. It seems to me that this would rather promote the formation of the angle salient forward.

Besides the forms of fracture now specified, there are cases of general smash of the bones entering into the elbow-joint. Thus, Beach<sup>3</sup> reports a case of compound fracture and separation of the lower epiphysis of the humerus, with crushing of the ends of the radius and ulna, in a boy aged eight, who had been run over by a horse-car.

Such injuries involve almost of necessity the total loss of mobility of the elbow-joint, as well by reason of the damage to the soft parts apt to attend them, as by the irregularity of union of the fragments, and the obliteration of the joint-cavity by inflammation. Of course, if the vessels and nerves are torn, there is danger of gangrene, and amputation may be imperatively demanded. If, however, the vessels have escaped, the arm may be placed in such a position as to make it most useful, and the case treated with the expectation of ankylosis.

A much better result, however, can be attained, if the muscular and ligamentous tissues have not been destroyed, by the excision of the joint. Beach, in the case just cited, adopted this course, and his little patient made a perfect recovery, the arm being as useful as the other, although three inches shorter. The operation may be done as a primary procedure; but there are some advantages in waiting until a later period.

*Fractures of the olecranon* are very rare in children. The youngest case known was reported by Eames,<sup>4</sup> in a child only four years of age, who fell on the elbow. Hamilton records one in a boy aged seven, which occurred during the reduction of an old backward luxation of the elbow. He mentions one which had happened to a boy aged fourteen, and which he examined sixty-nine years later; the union seemed to have been bony.

In the Warren Museum<sup>5</sup> there is a specimen with the following history: a boy aged eight injured his elbow, and four or five years afterwards noticed something movable in the joint, which prevented its flexion; when he was

<sup>1</sup> Bull. et Mém. de la Société de Chirurgie, 1880.

<sup>2</sup> British Medical Journal, February 9, 1889.

<sup>3</sup> Boston Medical and Surgical Journal, January 4, 1877.

<sup>4</sup> British Medical Journal, July 16, 1887.

<sup>5</sup> Catalogue, p. 171.

twenty-three years old it was excised, and was supposed to be the detached olecranon.

Fletcher<sup>1</sup> met with a fracture of both olecranons, in a boy aged sixteen; upon his death less than a year after, bony union was found on each side.

Annandale,<sup>2</sup> in the case of a boy aged sixteen whose olecranon was fractured by the kick of a horse, found the fragment drawn up and united to the humerus; he laid open the parts, divided the triceps, and sutured the fragment to the body of the ulna, with good result.

The best position of the limb for treatment is with the elbow not straight, but nearly so,—say at an angle of about one hundred and thirty-five degrees,—so that the trochlea shall act as an aid to the splint; the fragment should be drawn down by strips of adhesive plaster properly applied.

*Fractures of the coronoid process* are claimed to have been observed in a number of cases. Hamilton doubts them all, but, as it seems to me, on insufficient grounds. Duer,<sup>3</sup> in the case of a boy aged six who had fallen from a hay-mow, could grasp the fragment between his thumb and finger.

Liston's case<sup>4</sup> has become classical, although the account is so wholly wanting in detail as to have no practical value. He says merely, "I saw a case lately in which the injury arose in consequence of the patient, a boy of eight years, having hung on for a long time from the top of a high wall by one hand, afraid to drop down."

One case presented itself to Hamilton, in which a boy nine years old had fallen, and had a backward luxation of the elbow, easily reduced, but recurring as easily; he formed and expressed the opinion that the coronoid process was broken off; but five months later, finding that the motions of the joint were perfect, and that "if the coronoid process had ever been broken it was now again in its natural position, and with every structure about it in a condition as complete as it was before the accident," he thought his view disproved.

Annandale<sup>5</sup> has reported a curious case, in which, excision of an elbow (luxated backward and rigidly fixed) being performed, the tip of the coronoid process was found broken off, drawn upward and inward, and attached by fibrous adhesions to "the *posterior* aspect of the inner condyle." The patient was a boy twelve years of age.

These four are the only instances recorded, so far as I know, in children.

It seems to me that this lesion should be classed among the "sprain-fractures." Between the forward push of the humerus and the upward pull of the brachialis anticus, the process is partly split off and partly torn off.

<sup>1</sup> Medical Times and Gazette, August 16, 1851.

<sup>2</sup> Edinburgh Medical Journal, February, 1885.

<sup>3</sup> American Journal of the Medical Sciences, October, 1863.

<sup>4</sup> Practical Surgery, p. 75.

<sup>5</sup> Edinburgh Medical Journal, February, 1885.



The symptoms need hardly be detailed, but the most important will be difficulty in voluntary flexion of the elbow, and the detection of the fragment.

As to treatment, the elbow should be flexed, and kept so by means of a suitable splint for three or four weeks at least. Extension should then be cautiously and gradually made.

**Fractures of the forearm**, involving both bones, are in children more commonly met with than those of any other part of the skeleton. Coulon says that of one hundred and forty fractures treated in one year at the Hôpital Ste.-Eugénie (Enfants Malades) thirty-eight, or over twenty-seven per cent., were of the forearm; and other authorities give nearly as large figures. The most frequently assigned cause is a fall on the hand. Humphry<sup>1</sup> saw one case, in a child, from convulsions in whooping-cough. Plunket<sup>2</sup> has reported a case in which a child was born with a fracture of the right forearm, apparently caused by the violent contractions of the mother's womb; but there was also talipes varus of the right foot, and the thumbs were flexed into the palms. The result was good.

Incomplete fracture, or bending of the bones, first thoroughly studied in this region, occurs much oftener here than elsewhere. Coulon gives seven cases observed by him, and quotes nine others from different sources. Occasionally one bone is broken through, and the other only partially so; I think in such cases it is always the radius in which the separation is complete.

Sometimes the two bones give way at the same level, but often the radius is broken higher up than the ulna. Not infrequently, however, the radius is fractured near the wrist, the ulna yielding at or about the middle. The mechanism of these fractures does not seem to need explanation.

Usually the symptoms are unmistakable. There is pain, helplessness of the limb, and deformity. This deformity generally consists in an angle more or less pronounced, and salient toward the dorsal aspect of the forearm; sometimes, however, the angle is in the opposite direction, the projection being on the palmar surface. If the fracture is complete, there is mobility and crepitus.

A good deal of bruising is apt to attend these injuries, especially toward the wrist, where there is no great thickness of soft parts; and sometimes the fragments seem very near penetrating the skin. Compound fractures of this part are not, however, common.

Along with the angle just mentioned, there is almost always a certain amount of twisting, due partly to the fracturing force, and partly to muscular action.

Union takes place readily in the majority of these cases. I have seen it firm on the fourteenth day, in a little girl three years of age.

---

<sup>1</sup> British Medical Journal, November 15, 1884.

<sup>2</sup> Nashville Journal of Medicine and Surgery, August, 1879.

Generally speaking, the great danger to be apprehended is the permanent disability of the member from union of the fragments in a faulty position. Hamilton, however, mentions an instance in which a boy aged ten, badly treated by an empiric, died of tetanus on the sixth day. And it must be borne in mind that gangrene has repeatedly caused the loss of a portion, or even of the whole, of the limb, by reason either of too tight bandaging or of interference with the vessels by the fragments. Of this Hamilton records five cases observed by himself.

When we examine the skeleton of the upper extremity, it is clear that the interosseous space in the forearm is widest when the hand is in a state of semi-pronation, with the thumb directly upward. Hence, in view of this fact only, this would be the best position to maintain in the cases now in question. But if the fracture of the radius is above the insertion of the pronator teres muscle, its upper portion will be rotated outward by the supinator brevis, as well as by the biceps; and if union takes place under these circumstances the extent of supination will be greatly limited. In such cases, therefore, the lower fragment should be made to follow the upper, by putting the whole forearm in complete supination, in which posture the interosseous space is nearly as wide as in semi-pronation.

With regard to the ulna no such precaution is needed, as it has only a hinge-motion at the elbow, and no rotation; and, being subcutaneous in its whole length, the accuracy of its line can be readily ascertained.

Upon being called to a child with fracture of the forearm, the surgeon's first duty is to determine the seat of the injury in each bone. The nearer the wrist it is, the greater the chance of damage to the vessels. Anæsthesia may be necessary to a thorough examination and reduction. If the fracture of the radius is below the insertion of the pronator teres, the fragments may be brought into proper relation by extension from the wrist, an assistant making counter-extension from the elbow. The sufficiency of the interosseous space can be determined by the surgeon passing his hand up and down, with the fingers on one side and the thumb on the other, the little patient's thumb being upward. The proper apposition of the fragments being thus assured, two splints are to be applied, one on the dorsal and the other on the palmar aspect of the forearm. The extension of the palmar splint up along the inner side of the upper arm, with an angle at the elbow, will effectually prevent rotation of the forearm; the palmar splint should also reach down as far as the ends of the fingers, so as to support the whole hand. The dorsal splint need only reach from the elbow to the wrist.

These splints should be of such width as fully to protect the forearm from the pressure of the turns of the bandage, which would otherwise tend to crowd the fragments together; but they should not be so wide as to allow of lateral displacement. It is not necessary to apply compresses to keep the bones apart, but my own practice is to make the raw cotton padding a little fuller along the middle.

Much care must be taken in putting on the bandage, lest, on the one hand, the fragments should not be duly controlled, or, on the other, there should be too much pressure. I consider the proper dressing of a fractured forearm in a child a somewhat severe test of surgical skill.

In the case of the radius being broken above the insertion of the pronator teres, the same precautions are to be taken, but, instead of the two splints, only one, an anterior angular one, is to be used.

Gayraud<sup>1</sup> has recorded the case of a girl twenty-eight months old who had had both forearms broken twenty months before; on the right side union had taken place with the fragments at a right angle "like a second elbow." On the left side the angle was much less marked. Straightening was accomplished, and the ultimate result was good.

Dunn<sup>2</sup> met with a case of incomplete fracture at about the middle of the forearm, in a girl two and a half years old; it was easily reduced, the radius giving way with a "crack," and recovery was complete in three weeks.

Robson<sup>3</sup> saw a boy six years old who when two years of age had been run over by a cart, and had probably sustained a fracture of both bones; he had had no treatment, but the only trace of the injury was a projection of the radius upward and inward just below its head; supination was impaired.

Canniff<sup>4</sup> says, "Recently I have had under my care an incomplete fracture of the radius, with compound fracture of the ulna, about two inches from the wrist-joint." The patient, a boy eight years old, had fallen on the ground on his hand.

Dr. H. R. Wharton informs me that he saw in 1888 a boy aged twelve who by a fall from a horse had sustained "a fracture of the lower end of the radius, with great deformity, the hand being markedly drawn inward, and the ulna being decidedly curved inward, the point of greatest curving being about two inches above the styloid process. In making pressure to reduce the deformity, the ulna gave way with a snap at the point above mentioned." Reduction was then easy, and the boy recovered, with "a very perfect arm."

I have recently had at the Pennsylvania Hospital a boy aged eight years who some months previously had sustained fracture of both bones of the right forearm about one inch above the wrist. Necrosis of the fragments followed, and I removed the end of the diaphysis of the ulna and part of that of the radius, leaving the epiphyses in place.

In cases where there is much bruising of the soft parts, and especially when penetration of the skin by the fragments has been threatened, it is

---

<sup>1</sup> Gazette Hebdom. des Sciences Médicales de Montpellier, Sept 3, 1887.

<sup>2</sup> Transactions of the Minnesota Medical Society, 1881.

<sup>3</sup> Lancet, March 21, 1885.

<sup>4</sup> Manual of Surgery, 1866, p. 293.

much safer to apply lead-water and laudanum, or even evaporating lotions, with somewhat loose bandaging, until the parts are in a better condition to bear pressure. Of course the fragments are to be carefully adjusted in the first place; and the child will probably of itself avoid any motion, for fear of pain.

When the fracture is compound, it must be treated on the usual principles, the healing of the wounds being promoted by the most rigid antiseptics; the proper position of the bones being meanwhile maintained as accurately as possible. A good result can often be obtained in children under circumstances which in an adult would call for amputation.

Should a case present itself in which union has taken place with the fragments at an angle, an attempt should be made to correct the deformity by bending the callus, or by refracture if consolidation is complete. Or, if there has been rotary displacement, it may be justifiable to cut down and expose the fragments, and to suture them together in proper relation.

While maintaining in the fullest degree the statements already made as to the importance of careful and accurate treatment of fractures of the forearm, I would note, as a matter of curiosity, that Hamilton<sup>1</sup> mentions three cases of young children in which no dressings whatever were employed, yet in which the results obtained were perfect. He refers to another instance<sup>2</sup> in which a boy of ten years, after a fracture near the lower end of the forearm, had so great a deformity that refracture was seriously thought of by his attendant; gradually, however, the limb became straight, and eighteen years afterwards there was no trace of the injury.

*Fractures of the radius alone* may occur at any point, but, as in adults, are far more frequent close to the wrist. Stimson mentions a curious case in which, in a boy aged thirteen, the outer half of the head of the bone was separated by a blow from the runner of a sled; the diagnosis was verified upon excision of the joint, made necessary by suppurative arthritis. Foulerton<sup>3</sup> has reported the case of a boy nineteen months old, whose hand was pulled upon, with the result of fracturing the radius through its upper epiphysial line, and the clavicle at the junction of its middle and outer thirds.

Of fractures at any point in the length of the shaft, little need be said, as the condition of things is very similar to that in fractures of both bones.

A case is reported by Waitz<sup>4</sup> in which a boy aged fifteen fell from a scaffold, sustaining a compound fracture of the right radius, and a simple

<sup>1</sup> Report on Deformities after Fractures, in Transactions of the American Medical Association, 1856, pp. 198 and 199.

<sup>2</sup> Case 28, op. cit., p. 201.

<sup>3</sup> Lancet, October 2, 1886.

<sup>4</sup> Report of Esmarch's Clinic, Archiv für Klinische Chirurgie, 1877, vol. xxi.

one of the left ; on the sixth day there was difficulty of swallowing, and on the ninth death occurred from tetanus.

When the radius is broken near its lower extremity, it is almost invariably by a fall on the hand. These fractures are generally said to be infrequent in early life ; but I recently had at the Pennsylvania Hospital, within forty-eight hours, four cases of Colles's fracture in patients between five and twelve years of age. All these were from simple ordinary falls on the hand ; there was no ice (it was in October) or any other circumstance to account for the coincidence. I have repeatedly seen this injury on both sides, from falls from greater or less heights. In one case, many years ago, a boy about ten years old fell five stories, with no other damage ; he made a good recovery.

Sometimes, no doubt, the portion separated is the epiphysis ; but I think this is very rare. A case is quoted from Brunner<sup>1</sup> in which a boy aged fourteen had an injury of this kind, followed on the fourteenth day by tetanus ; upon resection of the bulky callus, and freeing of the radial nerve, the symptoms disappeared. Butler<sup>2</sup> has recorded a curious case, in which a boy of fourteen, by a fall from a height of thirty feet, had the styloid process broken off and drawn upward an inch and a half, where it became firmly united.

The symptoms of fracture of the radius close to the wrist are very characteristic, especially in thin children. Just above the joint there is a more or less abrupt swelling on the dorsum, and on the palmar surface, corresponding to the fold of the joint, there is a deep transverse furrow. The hand is helpless, and generally strongly pronated. Crepitus is apt to be very readily elicited, and mobility of the fragments often exists. I have never seen in a child the impaction which so commonly attends these fractures in adults.

Reduction is generally not difficult, but the fragments readily slip out of place again. I think, therefore, that the treatment of these cases in children should differ from that in adults, in whom the fracture, once fully reduced, is apt to remain so. I think the Coover splint (Fig. 16) the best

for the purpose of giving the parts perfect support in a comfortable position. It is very important to select the proper size. Should this splint not be at hand, a very good substitute can be made by cutting out

FIG. 16.



Coover's splint.

a thin piece of wood of the shape of the forearm and hand, and then fastening a block of wood on it so as to fill up the concavity of the under surface of the forearm near the wrist ; this block should be thicker at its radial side,

<sup>1</sup> London Medical Recorder, July 15, 1886.

<sup>2</sup> New York Medical Journal, November, 1857.

and slope off toward its ulnar margin (Fig. 17). A small semi-oval block should be glued or nailed on to correspond to the hollow of the hand. This splint, it will be seen, resembles somewhat the "Bond" splint, which, however, is usually made with a total disregard to anatomy, and the employment of which has left many a misshapen wrist.

Levis's splint (Fig. 18) would answer very well, the small size being employed.

Thorough reduction having been made, the splint, properly padded with raw cotton or with a double layer of canton flannel, is applied, and secured by means of a bandage. In the case of restless or unruly children

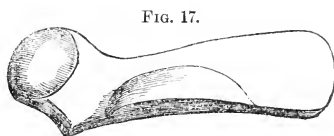
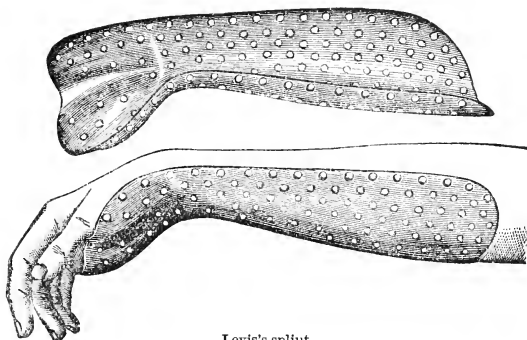

FIG. 17.

Splint for fracture near lower end of radius.

FIG. 18.



Levis's splint.

one or two wide strips of rubber adhesive plaster may be cast around the splint and the forearm before putting on the bandage. The hand should be supported by a sling.

Nearly all American surgeons use some form of palmar splint in these fractures. But if circumstances prevent the procuring or making of such an appliance, a straight splint may be adapted to the back of the forearm and hand, and will answer a very good purpose, at least as a temporary resource.

*Fractures of the ulna alone* are very rare in children. Bellamy<sup>1</sup> has reported one in the upper third of the bone from a fall on the hand, in a child six years of age. In the museum of the Pennsylvania Hospital there is a specimen of double fracture of the ulna, from a boy aged fifteen, the forearm having been bent around a revolving shaft. "The upper fracture is near the junction of the upper and middle thirds, and is somewhat

<sup>1</sup> British Medical Journal, September 16, 1876.

oblique. The lower fracture is in the lower third, and is transverse. At the time of removal the fractures were not complete, the fibres of the bone which remained unbroken being much bent."

Pain, swelling, and tenderness and crepitus at a certain point, will indicate the character of the injury.

The treatment should be the same as for fractures of both bones at or below the middle.

It should be remembered that fractures of the ulna may be seriously complicated by other injuries. Hamilton gives two instances in boys aged nine, in which the ulna was broken, and the head of the radius dislocated forward. Careful examination of the whole limb should, therefore, be instituted in every case, for the surgeon's credit as well as for the patient's advantage.

**Fractures of the carpal bones and of the bones of the hand** are extremely rare in children, except as the result of direct violence, and then the injury is apt to be compound. I have reported<sup>1</sup> the case of a boy aged three years, who two years before had had the first phalanx of the thumb broken by the fall of a heavy lid upon it, with non-union; by scoring the apposed surfaces of the fragments, and very careful splinting, consolidation was effected.

When in young subjects compound fractures occur in this region, the surgeon will do well to remember that nature sometimes exceeds our expectations; and even when the injury seems to be beyond repair, it may in a few days, under rigid antisepsis, assume a more hopeful aspect. Perhaps, at least, the amount of inevitable sacrifice by amputation may be found to be less than was at first supposed.

**FRACTURES OF THE BONES OF THE LOWER EXTREMITY.—Fractures of the femur** are, according to all authorities, among those most commonly met with in early life. The bone may give way at any point, but in the great majority of cases the shaft is the part affected.

Intra-uterine fractures of this bone have been recorded. Hofmohl<sup>2</sup> saw a case in which union had already taken place, and quotes another from Wagner; he also mentions a case of Schubert's in which the fracture was compound.

I have myself known of several instances in which, during the delivery of a child presenting by the breech, the femur has given way under the pressure of the blunt hook. Powerful expulsive contractions may produce the same effect, as in a case recently reported.<sup>3</sup> I may anticipate the discussion of treatment by saying that here the attendant thought "that the most natural position would be that which had been in utero—doubled up on the abdomen," and treated it accordingly, applying a second binder with

<sup>1</sup> American Journal of the Medical Sciences, July, 1875.

<sup>2</sup> Archiv für Kinderheilkunde, 1882.

<sup>3</sup> Lancet, March 5, 1887, communication signed "L.E."

an opening through which the leg and foot were passed : at the third week, when the report was made, there was "considerable firmness, very good position, though of course a good deal of thickening."

*Separation of the upper epiphysis*, the head of the bone, has been diagnosed more or less positively in a number of instances, and has once been proved beyond doubt by dissection, in a boy aged fifteen,<sup>1</sup> run over by a wagon. Sir Charles Bell<sup>2</sup> states that he has seen it result "from a fretful child casting himself backward while held in the nurse's arms," but in the entire absence of detail the case is without value. Hamilton mentions one instance in his own practice, in a boy fifteen years old ; he quotes one from Parker which had happened to a girl of eleven, seen seven years later, and one from Wardner in a boy of fourteen. South<sup>3</sup> had a case in a boy aged ten, suspected to be of this character ; the boy fell from a first-floor window upon the hip. Coulon's case, in which the neck of the femur gave way during the straightening of a diseased hip, although the force used was so gentle that the child did not cry, may have been a separation of the epiphysis. Barton<sup>4</sup> has reported an instance in which this injury was suspected, in a boy aged fifteen ; but it seems likely that there had been previously a pathological condition of the bone or of the joint, as the patient had limped for some weeks. Robson<sup>5</sup> saw a girl aged five, who had four years before fallen heavily upon her side ; no treatment had been instituted ; the foot was everted, and the limb shortened, measurements showing that the loss of length was above the trochanters. (If the statement of Sappey, that the upper epiphysis of the femur appears at the beginning of the second year, is correct, the probability is that the lesion here was of a different character from that now under consideration.)

I have now in my ward at the Pennsylvania Hospital a boy fourteen years old, who is just recovering from an injury of the left hip, which I believe to have been a separation of the epiphysis ; he was knocked down in a scuffle, striking on the hip.

The symptoms of separation of this epiphysis would not vary materially from those of fracture of the cervix femoris in adults,—shortening of the limb, eversion of the foot, crepitus and undue mobility, pain, and usually loss of power. All these were present in my case just mentioned. South's patient "suffered so little inconvenience that he had two or three times got out of bed and walked about for a short distance ;" and Wardner's, for twenty-four days, had only "a lameness in the hip-joint and some difficulty in walking."

As to treatment, absolute rest and moderate extension are the essentials, and should be maintained for three or four weeks at least, the condition of

<sup>1</sup> Bousseau, Bull. de la Soc. Anatomique de Paris, April, 1867.

<sup>2</sup> Institutes of Surgery, 1838, vol. i. p. 110.

<sup>3</sup> Chelius's Surgery, Amer. ed., vol. i. p. 619.

<sup>4</sup> Medical News, July 14, 1883.

<sup>5</sup> Lancet, August 21, 1886.



the part being then cautiously tested, and the extension continued if there is found to be a tendency to renewal of the shortening.

Extra-capsular fracture of the *neck of the femur* is said by Lee<sup>1</sup> to have been seen by him in a boy aged ten; but no details of the case are given. Sir A. Cooper cites a case under the care of Mr. Gwynne, in which a boy aged fourteen had a dorsal luxation of the femur of a month's standing, in attempting to reduce which, by extension with pulleys, the neck of the bone gave way. This may have been a separation of the epiphysis, but under the circumstances it is quite possible that there was an extra-capsular fracture of the form commonly met with in adults. A good deal of strength in the limb was ultimately acquired. Leisrink<sup>2</sup> mentions the case of a boy aged seventeen who had a dorsal luxation of the femur, of six months' standing; in the attempt at reduction, the bone gave way close to the trochanters, "evidently within the capsule;" consolidation took place in thirty-five days, with two inches shortening; the luxation probably remained unreduced, but it is not so stated. Allis<sup>3</sup> has reported a case in which in a child eighteen months old there was found after death "a fracture of the neck of the right femur, with loss of substance." There were other injuries, to be hereafter mentioned, and an obscure history of traumatism, besides some evidences of rachitis.

Separation of the epiphysis of the *greater trochanter* is recorded by Sir A. Cooper as having been observed by Mr. Key in a girl aged sixteen, who had fallen on a curbstone, striking her hip; the diagnosis was verified by an autopsy. Bryant mentions a similar case in a boy aged twelve, under Mr. Poland's care. McCarthy<sup>4</sup> reports that a girl eight years old, having fallen on her left side, had an abscess in the hip, and this extended into the pelvis; pyæmia, with pericarditis, pleurisy, and pneumonia, ensued, and after death the trochanter was found detached. Roddick<sup>5</sup> saw, in a boy aged sixteen, an abscess of the hip, from which the necrosed trochanter was removed; it had been separated apparently by a muscular strain during exercise.<sup>6</sup>

When this fracture occurs, the trochanter may be entirely drawn away, and it will be missed from its proper place. If still attached, it will be movable, with crepitus. In the former case very little can be done in the way of treatment; in the latter, fixation of the fragment may be effected by means of adhesive strips carefully adjusted.

*Fractures of the shaft of the femur* are for convenience divided into those

<sup>1</sup> Chicago Medical Journal and Examiner, March, 1879.

<sup>2</sup> Archiv für Klinische Chirurgie, 1872, Bd. xiv. S. 246.

<sup>3</sup> Transactions of the Pathological Society of Philadelphia, 1879, vol. viii.

<sup>4</sup> Transactions of the Pathological Society of London, 1874, vol. xxv.

<sup>5</sup> Canada Medical and Surgical Journal, November, 1875.

<sup>6</sup> In the Museum of the New York Hospital (Catalogue, p. 87) there is a specimen showing fracture of the femur through the line of junction of the neck of the bone with the shaft; a portion of the greater trochanter is also broken off. It was taken from the body of a girl aged nine, who had fallen out of a window.

of the upper, middle, and lower thirds. In children, as in adults, those of the middle third are much the most common of all.

Either direct or indirect violence may cause this bone to give way. In the latter case there is very often a twist impressed upon the bone, as well as the force at either end. A most extraordinary case is mentioned by Fayrer, in which a boy only thirty-four days old sustained a simple fracture of this bone by the bite of a jackal; union was complete in three weeks. A very few instances are on record in which muscular action has been alleged as the fracturing agent. One is the now classical case of Poupée-Desportes, in which a negro boy, in convulsions, broke both femora in their upper thirds. Another, quoted by Gurlt from Schröder, was that of a rachitic girl five years old, who for the fourth time in two years broke both femora while in a convulsion. A third, in a boy aged twelve, was reported by Lente;<sup>1</sup> an interval of eight months, however, elapsed between the two fractures, the second of which was still ununited when the boy died six weeks afterwards. Beck<sup>2</sup> has recorded an instance in which a boy six and a half years old was lifting another boy on his back, when his right femur gave way a hand's breadth above the knee.

"Spontaneous" fracture of the femur has been reported by Rankine.<sup>3</sup> A child aged six years "was simply walking across the floor, when its leg doubled up, the child falling instantly to that side." The femur was found to be broken in its middle third. The mother declared positively "that she was looking at the child walking over the floor at the time, and that there was no stumbling or anything, but only the leg seemed to double by the mere act of walking. It may be mentioned that the child did not seem to be in the best of health, although nothing very particular could be detected about it." In another case, reported by Cribb,<sup>4</sup> a boy aged eight had had coxalgia and abscesses in the right hip for four years; his left femur gave way at the junction of the middle and lower thirds as he turned in his carriage; union took place slowly but firmly.

The symptoms of fracture of the shaft of the femur are usually unmistakable. Walking is impossible; the limb is deformed, and usually curved by reason of the thickness of the soft parts, the convexity being, as a general rule, outward. In fractures in the upper third of the bone, the upper fragment is apt to be tilted upward by the action of the iliacus and psoas muscles. Of this Detmold<sup>5</sup> relates an instance in a child six years old. Here the convexity is forward, and the want of purchase on the short upper fragment makes it necessary to carry the lower one up after it, as it cannot be kept down. On handling, there is mobility at the seat of fracture, and more or less distinct crepitus.

---

<sup>1</sup> American Medical Times, July 21, 1860.

<sup>2</sup> Jahrbuch für Kinderheilkunde, 1886.

<sup>3</sup> Lancet, March 31, 1883.

<sup>4</sup> British Medical Journal, November 15, 1884.

<sup>5</sup> New York Journal of Medicine, March, 1856.

For the most part, union takes place rapidly in these cases. Coulon gives nineteen uncomplicated cases, of ages ranging from two to ten years, in which the average duration of treatment was almost exactly sixteen days. The shortest period was ten days, the child being two years old, and the longest thirty, the child being two and a half. My own experience would lead me to assign a longer time, say twenty days, as a safer limit. I think that after all restraint is removed from the limb the child should be kept in bed for a week before being allowed to try to walk. Coulon mentions the case of a serofulous boy aged seven, who had coxalgia; he fell out of bed and fractured the femur; extension being impossible, the limb was placed on a double inclined plane, and in eight days "there was a very solid callus."

Some swelling of the knee, from effusion into the joint, is apt to occur within a few days. I have never seen it persist after the uniting of the fracture, and generally it disappears in a much shorter time.

Fayer<sup>1</sup> mentions a very rare case: a Mohammedan boy aged twelve died of erysipelas supervening upon a simple fracture of the femur in its lower third.

Shortening, which is so apt to give rise to permanent lameness in adults, can generally be easily obviated in children, as the resistance to extension in them is so much less. Indeed, excellent results are often obtained without extension by special means. Unless in exceptional cases, there ought not to be an appreciable degree of shortening; and what there is may be expected either to be obviated by compensation, or to disappear with the process of growth.<sup>2</sup> Gross<sup>3</sup> records an instance in which an infant four weeks old was brought to him "on account of a fracture of the shaft of the right femur, caused two days previously by a child rolling over it in bed. The thigh was much swollen, and at least an inch and a half shorter than the sound one; all the extension and counter-extension that I could make with my hands failed to restore it to its normal length."

As to the treatment, there have been very great diversities of practice. We have the example of Paget and Callender<sup>4</sup> as a warrant for dispensing with all apparatus; "the child being laid on a firm bed, with the broken limb, after setting it, bent at the hip and knee, and laid on its outer side."

By others, notably by the late Dr. Sands,<sup>5</sup> of New York, plaster-of-Paris bandages have been warmly advocated. Bell<sup>6</sup> has spoken in strong terms of the advantages of this method. My own experience with it has been very favorable; but it needs to be carefully watched, lest, on the one

<sup>1</sup> Clinical and Pathological Observations in India, p. 237.

<sup>2</sup> The reader will do well to refer to an article by Dr. Hunt, in the American Journal of the Medical Sciences for January, 1879, in which the case of a boy aged eight is related, with interesting comments.

<sup>3</sup> System of Surgery, vol. i. p. 897.

<sup>4</sup> Bloxam, St. Bartholomew's Hospital Reports, 1867.

<sup>5</sup> New York Journal of Medicine, June, 1871.

<sup>6</sup> Archives of Pediatrics, May, 1884.

hand, the compression exerted should be too severe, or, on the other, with the subsidence of swelling, there should be too little control of the fragments. Hamilton was much opposed to it, and relates the case of a boy aged four in whom gangrene followed its use; but it seems to me that the bad result was due not to the method, but to inexcusable neglect on the part of the surgeon in charge. Mason<sup>1</sup> reports the case of a boy aged three, with a fracture in the upper third of the bone, successfully treated by this plan, the silicate of sodium, however, being substituted for plaster of Paris. I have myself employed silicate of potassium with great satisfaction, the advantage of it being that it solidifies very rapidly. Of the other materials used in solidifying dressings, glue, paraffin, starch, etc., it is needless to speak here, as the principle involved is the same in all.

Extension in some form is very generally used in fractures of the femur in children. Most of our cases at the Pennsylvania Hospital are put up like those in adults, with a proportionate weight attached by a cord passing over a pulley at the foot of the bed, for the purpose of making continuous extension. This cord is fastened to a bit of thin board about two inches square, placed in the middle of a strip of adhesive plaster, the ends of which are carried up along each side of the leg as far as the seat of fracture, and confined by strips or by a roller. Sand-bags of suitable size are placed at either side of the limb to steady it. When there is a tendency to angulation of the thigh, a splint of sheet-zinc or of binder's board is carefully moulded to the part, and bound on.

Hamilton recommends a sort of box, consisting of two long splints, one on each side, extending from the axillæ to beyond the soles, where they are connected by a foot-piece; this latter is so long as to keep the feet widely

FIG. 19.

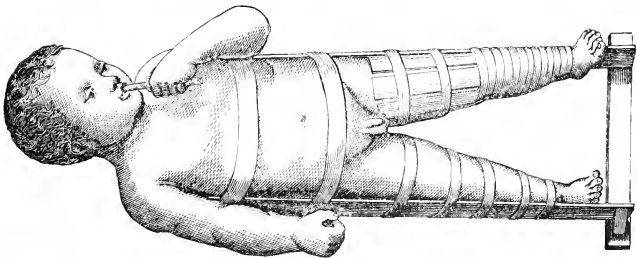

Hamilton's apparatus for fractures of the femur in children.

separated. Coaptation-splints of binder's board are applied to the injured thigh, and the leg is bound to the corresponding long splint with a roller. The remainder of the limb, the opposite limb, and the body are made fast with broad and separate strips.

<sup>1</sup> Medical Gazette, January 10, 1880.

Vertical extension, as advocated by KümmeI,<sup>1</sup> I have never employed. Lenze,<sup>2</sup> reporting a case of its use in a boy aged two, commends the plan on account of its cleanliness; he says he received it orally from Schede, and did not know with whom it originated. A curious effect of this treatment has been observed in female children,—viz., vaginal catarrh; it is said to yield promptly to appropriate measures as soon as the extension is discontinued.

Smith's well-known anterior wire frame is reported by Wright<sup>3</sup> to have been used with good result in a case of fracture somewhat above the middle of the bone, in a child five years old. This method might answer well in those troublesome cases where the fracture is near the trochanters and it is impossible to prevent tilting up of the upper fragment. Perhaps the same should be said of vertical extension.

Whatever plan of treatment may be adopted, children with fracture of the femur cannot be prevented from wetting the bed, unless care is taken to protect it. Perhaps the best way to do this is to have a thin square pad of absorbent material, with oiled silk or rubber cloth beneath it, properly placed to receive the urine, and changed as often as it becomes soiled. Even the most constant watchfulness can hardly anticipate every action of the bladder.

As to the fecal discharges, they should be received in a bedpan warmed and very carefully placed under the child, the sound limb being raised for the purpose. Children above the age of mere infancy can be soon taught to give notice of their desire to have a movement.

A case of fracture of both femora, one compound, in a boy aged six years, has been reported by Peter.<sup>4</sup> Desault's apparatus was used on each (a long outer splint, reaching from the iliac crest to beyond the sole, and an inner one from the perineum to the ankle); union took place in twenty-nine days, and on the forty-third day the boy was walking out.

Union is sometimes very slow in occurring. In one case, reported by PoinsoI,<sup>5</sup> a boy aged ten had a fracture just below the trochanters, which did not consolidate for six months; the delay was ascribed to "local scurvy." Lyford<sup>6</sup> was called upon to treat a boy who had broken his thigh at the middle eleven months before; blisters having failed, a seton was passed, and after forty days of treatment the bone became firm. Marks<sup>7</sup> has recorded the case of a girl aged fourteen who at the age of two and a half years had a fracture of the femur at two points; it did not unite for six months, when a fragment was removed from the lower portion; the

---

<sup>1</sup> American Journal of the Medical Sciences, July, 1882, from Berl. Klin. Wochenschrift, 1882, No. iv.

<sup>2</sup> Berl. Klin. Wochenschrift, December 27, 1880.

<sup>3</sup> Transactions of the Medical Association of Georgia, 1879.

<sup>4</sup> American Journal of the Medical Sciences, July, 1865.

<sup>5</sup> Bull. et Mém. de la Société de Chirurgie, October, 1878.

<sup>6</sup> London Medical and Surgical Journal, July 1, 1829.

<sup>7</sup> Journal of the American Medical Association, November 6, 1886.

muscles shrank, and the knee became stiff. At thirteen years and seven months, the bone was again broken at the junction of the middle and lower thirds; plaster of Paris was applied for three months, and then the fractured ends were rubbed upon one another; the plaster was reapplied, and she got up upon crutches; union was finally obtained with one and one-fourth inches shortening.

When union takes place with great deformity, operative interference may be called for. Clénot,<sup>1</sup> in the case of an infant only forty days old, with the left thigh united at an angle of about one hundred and twelve degrees, from what was supposed to be an intra-uterine fracture, tried extension for three months; this failing, he cut down upon the bone and divided it with a chain-saw; union ensued with a straight but considerably shortened limb. Wasserfuhr in 1816<sup>2</sup> successfully resected the femur of a child aged five years, for union of a fracture above the middle, the fragments being at an angle of nearly ninety degrees. Langenbeek records a similar operation performed by him on a girl aged three, with a fatal result on the eighth day, caused, as he supposed, by carbolic-acid-poisoning.

Refracture has been resorted to with success in many instances. Buck<sup>3</sup> reported a case, in a boy aged five, in which four operations were required at intervals of four weeks; union was at last obtained with very little (one-fourth inch) shortening. Fayer<sup>4</sup> got a good result in two cases, an English boy aged fourteen, and a Hindoo boy aged ten. Heath<sup>5</sup> has recorded two, in boys aged seven and twelve respectively.

In 1882 a child three years old was brought to me with a very great deformity from an old fracture of the femur just below the trochanters, union having taken place with an outward angle of about ninety degrees. The lameness was very like that of hip-joint disease. The child had been allowed to walk while the callus was yet plastic, and the lower fragment had tilted up the distal end of the upper. Not being then a believer in antiseptic surgery, I declined to attempt interference; refracture was out of the question, the upper fragment affording no purchase.

In 1879 I refractured the femur of a boy aged twelve, who had sustained a very severe fracture nearly three months before by his leg being entangled in a carriage-wheel, and who had been ignorantly treated in the country; the deformity, which was very great, was completely corrected.

When necrosis affects the femur, it sometimes happens that the shell of new bone breaks. An instance of this kind came under my notice in the Pennsylvania Hospital, in a boy aged thirteen, from whose thigh I had removed an enormous sequestrum some time before; union took place very

<sup>1</sup> Zeitschrift für die gesammte Medicin, 1836, Bd. iii., from Gazette des Hôpitaux, May, 1836.

<sup>2</sup> Norris, Contributions to Practical Surgery, p. 124.

<sup>3</sup> Transactions of the New York Academy of Medicine, 1855.

<sup>4</sup> Op. cit., p. 529.

<sup>5</sup> Lancet, March 5, 1887.

readily. Thompson<sup>1</sup> has reported a case in which the fracture took place very near the knee, in a boy aged nine, who died from hemorrhage, the artery having been wounded by the sharp upper fragment. A very similar case, in a boy aged sixteen, whose life was saved by amputation, has been reported by Brooke.<sup>2</sup> In the Warren Museum<sup>3</sup> there is a specimen from a case in which a boy aged fifteen jumped from a wall, injuring the femur so that inflammation and necrosis followed, and the bone was broken, uniting with a shortening of three or four inches; repeated attacks of inflammation ensued, and the knee-joint became involved, so that twelve years later amputation was performed with a good result.

Compound fractures of the femur are very rare in children; they are to be treated on the same principles as in adults, but, as in other parts of the body, the youth of the patients affords more chance for successful conservative surgery. Amputation is sometimes demanded. McFarlane,<sup>4</sup> in the case of a little girl aged two, who was run over by a wagon, removed the limb at the hip-joint; and the child, after passing through a severe attack of bronchitis with diarrhoea, was discharged cured on the thirty-eighth day.

Fisher,<sup>5</sup> in 1803, in a boy aged nine, resected three inches from the lower fragment of a femur broken at its upper part; the fracture was compound, and no union had taken place; in less than two months consolidation occurred, and a complete recovery ensued, but with the limb shortened.

Fractures at the lower end of the femur have been recorded as occurring to children in a few instances.

Sir A. Cooper relates the case of a boy who had his leg entangled in a wheel and sustained a transverse fracture, with separation of the external condyle, which exfoliated; ankylosis was expected, and the limb was dressed in the straight posture, but five months after the accident the boy walked well, with free use of the joint.

Langenbeck treated a boy aged six who by a fall had a T-fracture of the condyles, the knee-joint being full of blood; yet recovery took place with almost normal movements, and no shortening. Hamilton records the case of a boy aged seven who in jumping down about three feet broke the femur obliquely downward and backward just above the knee; the limb was placed on a double inclined plane; gangrene of the foot ensued, but the fracture united well, with fair motion of the knee. The gangrene was supposed to be due to pressure upon the artery by the end of the upper fragment.

A case of separation of the inner condyle of a boy aged fifteen, by the kick of a horse, was reported to Hamilton by Riggs; the whole leg, with the fragment, was displaced upward and inward, reduction being accomplished with much difficulty; but a good recovery ensued.

<sup>1</sup> Dublin Quarterly Journal of Medicine, August 1, 1847.

<sup>2</sup> Transactions of the Pathological Society of London, 1855, vol. vi.

<sup>3</sup> Catalogue, p. 236.

<sup>4</sup> London Medical Gazette, November 19, 1831.

<sup>5</sup> London Med. and Phys. Journal, 1804.

Separation of the *lower epiphysis of the femur* is a very grave accident, but more frequent than disjunction of any other epiphysis, nearly fifty instances being on record.<sup>1</sup> Allis has reported<sup>2</sup> a case in which there was a complete separation in one limb and a partial one in the other; the child, who was about eighteen months old, and presented some signs of rachitis, was supposed to have been hurt, about two weeks before its death, by an older one sitting on its legs.

With regard to a number of the cases the details given are very scanty. The diagnosis can be positively made only when the injury is compound, or when amputation of the limb or the death of the patient affords an opportunity for the dissection of the parts. Very great violence is necessary to produce this lesion. A curiously frequent cause of it has been the entanglement of the limb in the wheel of a moving vehicle; twenty-four such cases have been published, and one has recently been under my own care. Several of the patients had their limbs caught in ropes, or in machinery; one fell a distance of eighty feet. The mechanism of it would seem to be over-extension of the knee, with more or less twisting and traction upon the leg.

Such accidents would seem very unlikely to happen to girls, yet there are five among the subjects of the records.

When this injury is compound, the wound is generally at the back or inner side of the limb; in one case it is stated that the end of the shaft protruded forward.

My own case was a strikingly illustrative one. A boy aged nine was hanging on at the back of a wagon, when his leg was caught in the wheel. A large wound existed at the lower and back part of the thigh, and through this the end of the diaphysis, stripped of periosteum, protruded; the condyles were still in contact with the head of the tibia, but only by an edge, the whole epiphysis being rotated so that the articular face looked forward (upward) and the detached surface backward (downward); this was subsequently found to be due to the two heads of the gastrocnemius muscle. Ether was given, and a careful examination showed that, although there was very severe laceration and bruising of the soft parts, the vessels and nerve had not been torn, but had been pushed aside around the end of the shaft; they were, however, much stretched, and the blood in the artery was coagulated. Reduction was impossible, and an attempt to save the limb by

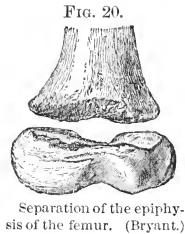

<sup>1</sup> Madame Lachapelle is quoted by Malgaigne and others as having seen this lesion produced in birth, by traction on the child's foot, the upper epiphysis of the tibia being also separated. But, as she says (*Pratique des Accouchemens*, tome ii. p. 225) that the limb was "altered by putrefaction," it does not seem to me that this case ought to be taken into the account any more than if the bones had been artificially macerated.

<sup>2</sup> *Transactions of the Pathological Society of Philadelphia*, 1878, vol. viii. p. 7.



resection seemed likely to be attended with such risks, that amputation was at once performed. The boy made an excellent recovery.

The periosteum has been noted as stripped up from the shaft in almost every instance. Seven times the tilting of the epiphysial fragment, above mentioned, has been observed.

Primary amputation was performed in eleven of the compound cases, with four recoveries, three deaths, and in four the result not stated. Secondary amputation was resorted to in ten, with five recoveries, and in five the result not stated. In three cases, and probably in two others, the amputations were intermediate, with one recovery, one death, and three results not stated. Resection was resorted to in seven cases, four compound and three simple; two of the latter were amputated later, and belong in the preceding list also. In the other five good results were obtained. In five cases, three of which were compound, reduction was effected with success; some doubt may exist as to the diagnosis in the two which were simple. Details are wanting as to seven cases; two of these, however, were museum specimens, and in one the diagnosis was verified by amputation.

Secondary amputation was performed in one case on the thirteenth day, for hemorrhage; in one after three months, for stretching of the nerve by the end of the shaft; in one case after several years, for aneurism; in two for abscess, in three for gangrene, and in the other two for reasons not stated.

Sometimes the separated epiphysis is itself broken into two or more fragments; this condition is represented in Fig. 21, which also shows (at the right) a small portion of the shaft detached along with the epiphysis. This, as already stated, has been frequently observed.

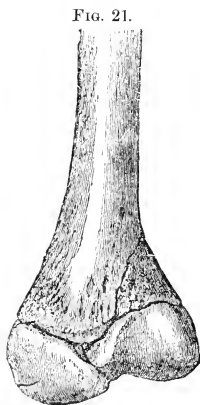

FIG. 21.  
Separation of the lower epiphysis of the femur, with fracture. (Holmes's System of Surgery.)

As to treatment, enough has been said to show that it must vary with the circumstances presented by each case. Reduction should, of course, be tried, if the damage to the soft parts has not been such as to forbid an attempt to save the limb; to effect it, the end of the diaphysis may have to be sawn off. When there is a wound, and the shaft projects through it, this is readily done; but if the skin is unbroken, an incision may be made for the purpose, as the additional risk involved in so doing would be small as compared with that of leaving the bone to itself. The displacement being corrected, a dressing such as that employed for any like case of fracture of the thigh should be applied.

The question of amputation is, of course, a very grave one, and involves points which can be settled only by consideration of the circumstances in each individual case.

(I have abstained from quoting the reported cases of this injury, because

there were no special points to be illustrated by them without extending the discussion beyond the space available to me.)

**Fractures of the patella** are extremely rare in children, the bone scarcely existing as such in them. Malgaigne's youngest case was that of a boy aged eleven; no particulars of it are given, but, from the fact that it was treated with his hooks, we may infer that it was transverse. Guersant<sup>1</sup> makes the vague statement that he had seen "only three or four" in his practice at the Hôpital de l'Enfant Jésus; but in the utter absence of details this is open to some doubt.

Hamilton says that he saw a small piece of the margin of the bone broken off by a direct blow, in a boy aged five; and S. Ashhurst<sup>2</sup> has reported the case of a girl aged four who, by falling on a marble, split the bone down vertically, near its upper and outer edge.

**Fractures of the bones of the leg** are comparatively infrequent in early life, although in a number of instances they have occurred to children within the womb. Malgaigne, among five hundred and fifteen cases, found but one as young as four years, and but twelve between five and fifteen years. Beck's tables<sup>3</sup> show, out of two hundred and forty-seven cases of fracture in children, but twenty-five, or ten per cent., in the leg, as against ninety, or about thirty-six per cent., in the thigh.

The tibia alone suffers oftener than both bones; fracture of the fibula alone is exceedingly rare. The seat of fracture, in a large majority of the cases, is in the middle third of the leg. Direct violence from falls or blows would seem to be the most frequent cause, although, of course, the exact facts can seldom be obtained, even from grown-up witnesses of an accident. D. P. Smith<sup>4</sup> saw a case in which a boy aged six sustained a fracture of both bones by the leg being caught in the wheel of a carriage. When the violence is indirect, it is probable that there is in addition to leverage a twist of the limb. In either case the obliquity of the line of fracture is, as a rule, much less than it generally is in adults.

Partial or incomplete fractures of the leg have been recorded. Thore<sup>5</sup> quotes cases observed by Campagnac, Fleury, and Voillemier, the diagnosis in the two former being verified by dissection. Another case, in a boy aged six, has been reported by Gray;<sup>6</sup> there was no crepitus, but the leg was deformed, straightening, however, in ten days under the pressure of splints. Bryant has figured a curious case in which a girl aged twelve had had a green-stick fracture united at an angle, and this angle filled up by a deposit of new bone, so that the antero-posterior diameter was six inches.

---

<sup>1</sup> Notices sur la Chirurgie des Enfants, Paris, 1864-67.

<sup>2</sup> Medical News, August 4, 1883.

<sup>3</sup> Jahrbuch für Kinderheilkunde, 1886.

<sup>4</sup> American Medical Times, July 28, 1860.

<sup>5</sup> Annales de Chirurgie Française et Étrangère, February, 1844.

<sup>6</sup> American Journal of the Medical Sciences, October, 1853.

Fracture from necrosis has been recorded by Fayrer;<sup>1</sup> an English boy aged three and a half years had necrosis of the shaft of the tibia, and a sequestrum was removed; some months after, while healing was progressing, he fell and broke the new bone; union took place, but rather slowly.

As to the treatment of fractures of the leg in children, my own practice has always been to employ splints of binder's board, one on either side of the leg; they should extend from close to the knee to the foot, supporting the latter so that it cannot rotate. They should be well softened in hot water, and carefully moulded to the limb; they are then lined with an even layer of raw cotton, and bound on with a roller bandage. I have never seen a case in a child in which there was any difficulty in reduction. The inner edge of the patella, the inner malleolus, and the inner edge of the great toe should be in a line with one another.

Zinc or tin splints may be used in the same way. Some surgeons employ the immovable apparatus, with plaster, paraffin, or glue, from the first; but I think removable splints preferable. Care should be taken not to bind the limb too closely, lest the circulation be interfered with, as in Fleury's case above referred to, in one recorded by Holmes,<sup>2</sup> and in another reported by Krackowizer.<sup>3</sup> On the other hand, the apparatus must be so closely applied as to give perfect support and to prevent motion of the fragments.

There is good authority for the use of the "fracture-box" in children, but it necessitates their lying still, which they cannot always be made to do.

Suspension is needless in the case of very young children, but in older ones it may be made as in adults. My own method<sup>4</sup> of doing this has always seemed to me the most satisfactory.

As in the case of other bones in early life, union generally takes place very readily, and without permanent deformity. But it must not be taken for granted, because the child is comfortable, that all is well. On the contrary, in several instances which have come under my own notice, the limb has been in bad shape, although the little patient made no complaint whatever. And after the bone seems to be solidly united, care should be taken lest by the too early use of the limb the callus should yield, and a serious deformity result.

In the Warren Museum<sup>5</sup> there are three specimens singularly illustrative of the effects of neglect in fractures of the leg in early life. The bones tend to form an angle salient forward, and the lower fragments are crowded down close to the foot. In two of the cases firm bony union failed to occur, and in one amputation was finally resorted to. Watson<sup>6</sup>

<sup>1</sup> *Op. cit.*, p. 606.

<sup>2</sup> *Surgical Treatment of Diseases of Children*, p. 242.

<sup>3</sup> *American Medical Times*, November 7, 1863.

<sup>4</sup> *American Journal of the Medical Sciences*, April, 1874.

<sup>5</sup> *Catalogue*, pp. 204-5.

<sup>6</sup> *New York Medical Times*, October 1, 1851.

had to adopt a like course in the case of a boy aged fourteen, who when six years old had fractured his left leg, union taking place with the lower part bent inward and backward at nearly a right angle; after excision of a wedge from each bone by Stevens, the limb was straightened, but union failed to occur, and the skin gave way.

Better results are sometimes attained, especially since the introduction of antiseptic methods. Beck<sup>1</sup> records the case of a girl aged ten months who had had an intra-uterine fracture of the leg, united at a right angle; osteotomy was performed, with success. Coote<sup>2</sup> reports the case of a boy aged eight whose leg had been misshapen at birth, in consequence, as was supposed, of intra-uterine fracture; it was refractured at about three years, but union failed to occur; in his sixth year ivory pegs were introduced, but without success, as the pegs dropped out during an access of fever; the limb was, therefore, removed, and the lower fragment was found to be atrophied. Jones,<sup>3</sup> in the case of a boy aged sixteen, who at five years of age had sustained a Pott's fracture, excised the inner malleolus and upper surface of the astragalus, corrected the deformity, and effected a cure with a movable joint. I have myself chiselled away a wedge from the tibia, united with an angle salient inward, in a boy aged fifteen, with good result.

Union sometimes fails to occur. I have at present under my care at the Pennsylvania Hospital a girl only thirteen months old, with pseudarthrosis of both bones about one and a half inches above the ankle; the history, which is very obscure, is that the child was in some way caught under a street-car about six weeks ago; a small sinus probably communicates with the false joint. Waitz<sup>4</sup> records a case of non-union of both bones in a boy aged two and a half years, treated by the rubbing of the ends together, and the application of a plaster bandage; a cure was effected at the end of three months. Mott<sup>5</sup> gives an account of a girl who had an ununited fracture of both bones, dating from intra-uterine life; various means were tried during her first year, and at last a seton was employed, which seemed to be succeeding, when diffuse inflammation came on, and the uniting material was dissolved. In a note it is stated that resection was performed at the age of eleven years; but the final result is not given. Hamilton saw a girl aged seven who two years previously had had a fracture (probably green-stick) of the leg below the middle; it united at an angle, and six months later was broken over again by a surgeon, but no bony union ensued.

Whitman<sup>6</sup> has reported the case of a girl who at the age of three years

---

<sup>1</sup> Jahrbuch für Kinderheilkunde, 1886.

<sup>2</sup> Lancet, June 21, 1862.

<sup>3</sup> British Medical Journal, March 13, 1886.

<sup>4</sup> Report of Esmarch's Clinic, Langenbeck's Archiv, 1877.

<sup>5</sup> Transactions of the New York Academy of Medicine, 1857, vol. i. p. 82.

<sup>6</sup> Medical News, April 14, 1882.

underwent osteoclasia for deformity of the legs and arms; there was non-union in the left leg, which was finally overcome by resection and wiring, with an excellent result.

A curious case is recorded by Hamilton, in which a boy aged four had a compound fracture of his leg near the middle; an ulcer remained at that point, with frequent discharges of small scales of bone, for twenty-two years, when it closed, and he began to lose the use of both lower extremities. Probably the fracture had nothing to do with the paralysis.

So far, reference has been had to fractures of the shafts of the bones of the leg. Malgaigne mentions briefly the singular case of a girl aged eight, who had the inner malleolus fractured by the kick of a horse. Beaney<sup>1</sup> saw a fracture of the outer malleolus in a girl aged five and a half, who fell in running. I have myself seen a case of Pott's fracture in a girl aged fourteen, who had jumped from a third-story window; from culpable neglect on the part of the surgeon, a most deplorable deformity had ensued.

*Separation of the epiphyses* has been noted in a number of instances. Ashhurst<sup>2</sup> has figured such a lesion at the upper end of the tibia, from a boy aged eleven, in whom amputation was rendered necessary by railway crush. Heuston,<sup>3</sup> in the case of a boy aged eight, saw this accident followed by acute synovitis of the knee-joint, and seven months later by supuration, which was successfully treated by erosion, and drainage through the popliteal space. Stimson says that Verneuil "saw the epiphysis separated in a child six years old, whose leg had been caught between the spokes of a wheel; the joint was not opened."

Separation of the *lower* epiphysis of the tibia has been figured by Holmes,<sup>4</sup> who quotes another case from R. W. Smith. Martin<sup>5</sup> has reported a case of compound disjunction of the lower epiphysis of the tibia, with fracture of the fibula about four inches above, in a boy aged eleven, who recovered perfectly in two months. A very similar case, in a boy aged thirteen, has been recorded by Albee,<sup>6</sup> and another, requiring resection, by Clark,<sup>7</sup> who refers to sixteen other instances. In Holmes's specimen above mentioned the lower epiphysis of the femur and that of the fibula are also separated; and the shaft of the tibia is broken below the middle; the patient, a boy aged eighteen, was caught in a coil of rope, and the injury was such as to demand amputation. Voss,<sup>8</sup> in a case of compound separation of the lower epiphysis of the tibia, succeeded in reducing the protruding end of the shaft; but a portion of the epiphysis became

---

<sup>1</sup> Australian Medical Journal, September 15, 1884.

<sup>2</sup> Principles and Practice of Surgery, 3d ed., p. 269.

<sup>3</sup> Lancet, June 29, 1889.

<sup>4</sup> Surgical Treatment of Children's Diseases, p. 259.

<sup>5</sup> Boston Medical and Surgical Journal, September 27, 1877.

<sup>6</sup> Transactions of the Maine Medical Association, 1886.

<sup>7</sup> Glasgow Medical Journal, November, 1886.

<sup>8</sup> New York Journal of Medicine, November, 1865.

necrosed and was removed; the patient, a boy aged fourteen, recovered with a useful joint. Krackowizer<sup>1</sup> has reported a case of supposed traumatic separation of the lower epiphysis of the tibia, in a boy aged five; but, as the limb became gangrenous from tight bandaging, it seems possible that this may have had something to do with the lesion of the bone, which was only detected after amputation.

The upper epiphysis of the fibula is reported by Stimson<sup>2</sup> to have been torn off in a child two years old, with fracture of the shaft of the bone, in a street-car accident.

Arrest of growth of the bone has been mentioned and figured by Bryant as having followed a separation of the upper epiphysis of the tibia in a child aged eight; the fibula grew normally, and was, therefore, bowed outward.

Compound fractures of the leg are rarely seen in children. Gooch,<sup>3</sup> in a very extensive injury of this kind in a boy aged twelve, sawed off about five inches of the tibia (about nine inches protruding), and obtained an excellent result, the bone being reproduced. In another case, that of a boy aged eight, seen by him on the fifth day, the fractured end of the tibia had protruded through a small wound; emphysema had begun in the leg and extended up to the abdomen, and death ensued two days later. Norris<sup>4</sup> removed two inches of the tibia in the case of a boy aged twelve, "notwithstanding which he was discharged cured in eleven weeks, with shortening of the limb of but half an inch, the space occupied by the removed bone being filled by a firm and even callus."

Sir A. Cooper mentions a case in which, after the sawing off of the protruding end of the tibial fragment, no union occurred, and the boy was left permanently lame.

Fractures of the bones of the foot are not met with in children, except as the result of crushing force, and they are, so far as my observation has gone, always compound. Discussion of them here would be only in regard to the question of amputation, and this must be settled in each case on well-known principles.

---

## DISLOCATIONS.

Dislocations or luxations are proportionally much less frequent in children than are fractures. Thus, Malgaigne, among a total of six hundred and forty-three cases, found only twenty-one, or a little less than one-thirtieth, between the first and the fifteenth year of life; while out of three hundred and seventy-seven fractures, one hundred and fourteen, or

---

<sup>1</sup> American Medical Times, November 7, 1863.

<sup>2</sup> New York Medical Record, July 15, 1882.

<sup>3</sup> Cases and Practical Remarks in Surgery, 1767, p. 285.

<sup>4</sup> Contributions to Practical Surgery, p. 42.

about one-twelfth, belonged in that period. And in the records of ten years (1878-1887 inclusive) at the Children's Hospital in this city, there are but thirty-four cases of luxation as against five hundred and four of fracture. It is not difficult to account for this rarity of dislocations, when the small leverage afforded by the bones of children, the comparative strength of the fibrous tissues about their joints, and the slight amount of their muscular resistance are taken into consideration.

Mr. Jonathan Hutchinson<sup>1</sup> has advanced the curious view that the lesions supposed to be luxations in children are in reality epiphysal separations. Thus, he says that he has never met with a simple luxation of the shoulder in a child, but has seen many cases of detachment of the upper epiphysis of the humerus. Luxation of the elbow, he says, is not uncommon in adults, but in children is exceedingly so, the lesion supposed to be of this nature being separation of the epiphyses. With all respect for its distinguished author, I feel warranted from my own experience alone, to say nothing of that of the profession at large, in declaring that this proposition is wholly untenable. I am not aware, indeed, that it has ever been accepted by any one.

Dislocations may be pathological, the result of disease or of abnormal laxity of the joints, or traumatic, produced by violence. To the former class belong the congenital dislocations, met with especially in the hip, and those which occur in the course of fevers. Traumatic or accidental luxations may be due to direct violence, applied at once to the end of the bone which is displaced, knocking it out of its connection, or to indirect, applied at a distance, and acting on the bone as a lever. One point should be noted in the causation of such injuries in children: they are often produced by pulling upon the limbs, by which the ligamentous structures about the joints are put upon the stretch, and then the bones fail to go back into their proper relative position. This does not occur in the more rigid joints of adults.

Dislocations may be *complete* or *partial*. A *compound* dislocation is one in which the displaced end of the bone is exposed to the air by lesion of the soft parts; all others are termed *simple*. When a luxation is accompanied by other serious injury in its neighborhood, such as fracture, or great damage to vessels or nerves, it is said to be *complicated*. When the bone displaced remains in the abnormal position first assumed by it, the luxation is said to be *primitive*; if it passes into another, this is said to be *consecutive*. The term *old* is applied to a luxation which for any reason has existed without correction for so long a time that changes are likely to have taken place which render reduction difficult.

The mechanism by which bones are dislocated is not always easy to determine in adults; and in children the difficulty is much greater, since they can very rarely give a clear idea of the way in which an accident has befallen them.

---

<sup>1</sup> Medical Press and Circular, March 19, 1884.

The symptoms of luxation are pain, limitation of motion (passive as well as active), and deformity of the affected joint. Sometimes the absence of the dislocated bone from its proper position, and its presence elsewhere, can be clearly made out by feeling, if not by sight. Swelling is apt to occur very speedily, and may obscure the condition of the part. Echy-  
mosis very commonly ensues, just as in cases of fracture. There is also often a sound produced by the contact of the bones, which is to an inexperienced ear not unlike the crepitus of broken ends.

The diagnosis of a luxation is of great importance, since upon its early reduction may depend the usefulness of the limb in after-life. Usually the question is between fracture of the bone close to the joint, and displacement. Often the fact of the limitation of mobility will be sufficient to show that the latter lesion is present; if anaesthesia has been induced, as it always should be in cases of doubt, this sign is of more value.

If during the examination the deformity is corrected, and the normal mobility of the part restored, the diagnosis of luxation may be regarded as established. Let it be remembered that in children we are not so likely as in adults to have the moment of reduction indicated by a loud snap.

It must be borne in mind, and especially as regards the elbow, that luxation and fracture may be combined. Hence every case of dislocation should be carefully watched, after reduction has been effected, until the freedom and power of motion show clearly that the joint has resumed its normal state.

The prognosis of luxations in children is, as a general rule, much more favorable than in adults. The degree of violence to the soft parts is usually less, and the reparative powers of the tissues are of course greater. Yet the surgeon must not be too ready to promise a perfect result; since there may be stiffening of the affected joint, weakness of the limb, numbness or pain in the nerves which have been pressed upon, for some time, and the possibility of such after-consequences should be made known beforehand to the little patient's friends.

INTRA-UTERINE LUXATIONS are of rare occurrence, and, when met with, have almost always been the result of disease. Of all the joints, the hip is most frequently so affected, and on both sides. Cases are on record in which both knees have been dislocated, or rather abnormally movable, forward. In one case, reported by Rodrigue,<sup>1</sup> there was a dislocation of the left humerus, together with united fracture of the corresponding forearm; both lesions being accounted for by a blow received by the mother on her abdomen in the fourth month of her pregnancy.

LUXATIONS DURING BIRTH.—These must be of extremely rare occurrence. Scanzoni<sup>2</sup> says that he never met with luxations in the newly-born, "yet they occur, sometimes as congenital lesions, sometimes, and not very

<sup>1</sup> American Journal of the Medical Sciences, January, 1854.

<sup>2</sup> Lehrbuch der Geburtshilfe, 1853, p. 1060.



seldom, in the hip, as the result of powerful traction made on the lower extremities."

#### SPECIAL DISLOCATIONS.

**LUXATIONS OF THE VERTEBRÆ.**—A number of cases are on record in which, usually by great violence, separations of the vertebræ have taken place, and the relations between two of them have become changed.

Boyer<sup>1</sup> quotes from J. L. Petit an account of a child six or seven years of age "lifted up by a man (in order to see London, according to the vulgar saying) who took hold of the forehead and back of the head. The child struggled, became agitated, and died. It is to be regretted that there was no anatomical examination, though there is little doubt that the first vertebra was luxated upon the second."

Horner<sup>2</sup> saw a boy aged ten, who by a fall of twenty feet had sustained a luxation of the left oblique process of the fourth cervical vertebra forward, as shown by the distortion of the neck and by the position of the fourth spinous process. No attempt at reduction was made, on account of the risk involved. That this fear was not idle is shown by the case quoted by Boyer<sup>3</sup> from Petit-Radel, in which a child similarly injured died under the hands of the operator.

When only one oblique process is thus displaced, the injury is less grave than when it affects both sides. Occasionally one oblique process is driven forward, the other going backward; a rotary movement being given to the head and upper part of the neck. In any of these cases the chief danger is from interference with the spinal cord or with the nerves given off from it. Hemorrhage into the spinal canal, from ruptured vessels, or actual pressure by the displaced bone, may paralyze respiration.

If treatment is instituted, it should be with a view to disengaging the luxated process or processes, by extension of the neck and rotation in the direction opposite to that of the displacement. In the case of a boy aged twelve, W. J. Morton<sup>4</sup> succeeded in reducing a luxation of the fifth oblique process, by suspension from the head, with rotation. Stimson<sup>5</sup> quotes from Blasius a case of Richter's in which a boy aged eleven or twelve reduced a dislocation in his own neck; also one in which an accidental reduction took place from the patient falling out of bed.

Luxation of the dorsal vertebræ has been met with. Stimson<sup>6</sup> says, "In one case that has been under my observation for two years, the patient, a girl fourteen years old, has been in good health, although she remains completely paralyzed below the level of the breasts; the injury appears to

<sup>1</sup> *Traité des Maladies Chirurgicales*, 5ème éd., 1845, tome iii. p. 645. See, also, translation of first edition, by A. H. Stevens, 1816, vol. ii. p. 231.

<sup>2</sup> *American Journal of the Medical Sciences*, April, 1843, p. 512.

<sup>3</sup> *Op. cit.*, p. 650; translation, p. 234.

<sup>4</sup> *New York Medical Record*, October 4, 1879.

<sup>5</sup> *On Dislocations*, p. 142.

<sup>6</sup> *Op. cit.*, p. 158.

have been a diastasis at the fourth or fifth dorsal vertebra, and was caused by a fall down the narrow air-shaft of a tenement-house from a height of about sixty feet." A case of luxation of the twelfth dorsal vertebra from the first lumbar, by crushing force, in a boy of eleven, was reported by Swan,<sup>1</sup> who saw the patient eight years afterwards. In these cases there is no certainty that there has not been fracture, as well as luxation, unless the condition is determined by an autopsy. Sir Charles Bell<sup>2</sup> records that "an infant" was run over by a diligence; it died of croup thirteen months afterwards, and a post-mortem showed the twelfth dorsal vertebra completely luxated; the direction of the displacement is not stated, but it is said that "a very small portion of the bone had been broken off."

Two symptoms will be present in all these cases,—distortion of the vertebral column, as shown by the altered relation of the spinous processes; and paralysis, more or less complete, of all the parts below the seat of injury.

**LUXATIONS OF THE LOWER JAW.**—These are very rare indeed in children. Sir A. Cooper has recorded one produced in a boy by the effort to stuff an apple into his mouth. Malgaigne quotes from Delamotte the case of a girl eleven or twelve years of age who was kicked by a horse, the jaw being dislocated and fractured at the same time. Mr. E. Morris<sup>3</sup> has reported a curious case in which a girl of fifteen had her jaw displaced during sleep, from the act of sucking her thumb. Another occurred to Ballard.<sup>4</sup>

Malgaigne quotes from Tartra a case in which one condyle only was displaced during convulsions, in a child fifteen months old; the child was six years old when treated.

The symptoms in double dislocations are very characteristic. The mouth is more or less widely open, and fixed so; there is apt to be severe pain from tension of the muscles as well as from pressure on nerves. In the unilateral form the jaw is twisted to the opposite side from that on which the displacement has occurred.

The treatment consists in depressing the angle or angles of the jaw, and elevating the chin. In Tartra's case the jaw was fixed; it was forcibly depressed, and by means of small wedges a considerable improvement was effected, but the ultimate result is not known.

**LUXATIONS OF THE CLAVICLE.**—Either end of the clavicle may be dislocated.

**Luxations of the Sternal End.**—The clavicle may be displaced from the sternum forward, upward, or backward; but I know of only two recorded cases of any form except the first-named in a patient under fifteen years of age.

<sup>1</sup> Boston Medical and Surgical Journal, March, 1840.

<sup>2</sup> Injuries of the Spine, London, 1824.

<sup>3</sup> British Medical Journal, August 31, 1872.

<sup>4</sup> Mason, Lancet, February 23, 1878.

Fergusson<sup>1</sup> says, "I once saw a case of displacement of the inner extremity of this bone in a newly-born infant, which had happened during birth. The end rested in front of the sternum, and could be pushed into its proper place with great ease; but when left alone, it immediately slipped out again. Nothing was done, a new joint formed, and the child afterwards possessed as much power in the one arm as in the other."

Gross<sup>2</sup> records an instance of "congenital" luxation forward and upward, seen by him when the child was three months old. Wright<sup>3</sup> has reported a case of dislocation of the sternal end of the clavicle downward and forward, in a child aged ten months, by a fall out of bed. Melier is quoted by Malgaigne as having seen this accident in a girl aged four years, whose arm had been forcibly pulled upon. Mulvany<sup>4</sup> reports the case of a boy aged fifteen, thrown heavily upon his back at sea, in whom several of the left costal cartilages were dislocated behind the sternum, and the right clavicle was dislocated forward. It would seem likely that here the clavicle was fixed, and the sternum wrenched away from it. Hamilton mentions having seen two cases in boys, in neither of which could permanent reduction be effected.

In these cases there must be rupture of the sterno-clavicular ligaments (of the anterior one at least), and perhaps of the interclavicular and costo-clavicular ligaments. The displaced interarticular cartilage may sometimes be the cause of the difficulty experienced in maintaining reduction.

The diagnosis lies between this luxation and fracture of the clavicle close to the sternal end, or epiphysial separation. But the smoothly-rounded end of the bone, and the absence of the prominence at one side of the interclavicular notch, should indicate the true character of the lesion.

The treatment must consist in drawing the shoulder forward, so as to tilt the displaced end of the bone backward, and in making pressure upon the latter with a pad held in place by adhesive strips. Anæsthesia should be employed if there is any difficulty in the reduction.

A remarkable case is recorded by Morse<sup>5</sup> in which a girl aged eight was knocked down and run over, sustaining a dislocation outward (forward?) of the right clavicle, and a dislocation backward of the left, the first rib being also fractured. She had great venous congestion of the neck and head, which was relieved by the reduction, after much difficulty, of the left clavicle. Subsequently she did well. Hulke<sup>6</sup> gives another instance of backward luxation of the right clavicle, in a girl aged ten; the child was knocked down and run over, and it was supposed the horse stepped on her. There was great dyspnoea, relieved by drawing the shoulders backward. She made a perfect recovery.

---

<sup>1</sup> System of Practical Surgery, 5th ed., p. 228.

<sup>2</sup> System of Surgery, 6th ed., vol. ii. p. 1128.

<sup>3</sup> Boston Medical and Surgical Journal, April 1, 1880.

<sup>4</sup> Lancet, March 18, 1882.

<sup>5</sup> Cincinnati Medical News, December, 1877.

<sup>6</sup> Holmes's System of Surgery, vol. i. p. 970.

**Luxations of the Acromial End.**—The clavicle may be displaced from the acromion either upward or downward.

Hamilton reports one case of the former kind, seen by him in a girl four weeks old; it was congenital, and reduction could not be maintained.

A curious case of luxation downward is quoted from Melle by Malgaigne. It was that of a soldier, who at six years of age had his shoulder borne down by a great weight. The corresponding humerus was luxated at the same time, and remained so.

Chase<sup>1</sup> saw a case in which a boy aged eight fell, striking on his shoulder, and forcing the clavicle below the acromion. Under ether, reduction was easily effected by drawing the shoulder upward and backward.

The diagnosis of acromio-clavicular luxations can hardly present great difficulty, but the treatment may. Reduction is easily accomplished; but the displacement is extremely apt to recur. Support of the arm and hand by means of a well-arranged sling may be employed, and ultimately the complete restoration of function is probable.

**Luxations of Both Ends.**—Two cases are upon record in which luxation of both ends of a clavicle occurred simultaneously.

One, reported by North,<sup>2</sup> was that of a boy aged fourteen, who fell backward; the whole bone seemed rotated downward and forward on its long axis, its middle portion looking as if fallen in. Reduction was easily effected by pressure, and maintained by means of a "yoke" splint.

The other case, recorded by Haynes,<sup>3</sup> was that of a weakly girl aged thirteen, who was reaching up behind her head, when the clavicle gave way, the sternal end being luxated forward, and the acromial end upward. Reduction could be readily made, but the deformity reappeared.

**LUXATION OF THE STERNUM** (the manubrium upon the body of the bone) is recorded by Ancelet<sup>4</sup> as having been seen by him in a boy aged thirteen, who met with the accident while exercising upon a trapeze. There was intense pain at the seat of injury, aggravated by any respiratory effort; and the upper edge of the body of the bone was distinctly felt as a transverse ridge. Reduction was effected by strongly bending the body backward.

One case of congenital luxation of the xiphoid or ensiform cartilage is quoted by Malgaigne from Seger; an abnormal degree of mobility seems to have been the chief symptom, and a spontaneous cure ensued.

**LUXATIONS OF THE RIBS** have been observed in a few instances in early life. By great direct violence two of the lower ribs were driven forward from their attachments to the vertebræ, in a boy aged eleven, seen by

<sup>1</sup> Transactions of the Medical Society of the State of New York, 1879.

<sup>2</sup> New York Medical Record, April 16, 1866.

<sup>3</sup> British Medical Journal, January 27, 1872.

<sup>4</sup> Gazette des Hôpitaux, June 4, 1863.

Dunne, and in a girl aged fifteen, seen by Finucane.<sup>1</sup> Another case, affecting the first rib, has recently been reported by Quint.<sup>2</sup>

Anteriorly, the ribs may be displaced from the sternum. Flagg<sup>3</sup> reported the case of a girl aged ten, who ran against a table, striking the front of her chest; forty-eight hours afterwards she was exercising violently, when she felt pain, and "something gave way;" the fourth rib was found to be dislocated forward on the sternum. The result is not mentioned.

With regard to the diagnosis, prognosis, and treatment of such injuries, it is impossible to make any general statements, in view of the very limited experience recorded.

LUXATIONS OF THE HUMERUS are comparatively rare in early life; Malgaigne had collected but four instances under fifteen years of age. Yet Rodrigue<sup>4</sup> saw one which had occurred before birth. Stimson says that Bardenheuer quotes from Knox two cases in which the humerus was dislocated by obstetric manipulations. Mitchell<sup>5</sup> has reported a case in which a child, delivered by version by the foot, was found to have the head of one humerus luxated into the axilla; reduction was effected, and electricity was successfully applied for the relief of the paralysis of the muscles of the arm which ensued.

R. W. Smith<sup>6</sup> has described in detail five cases in which this lesion was congenital. In one congenital case, reported by Bouvier,<sup>7</sup> the patient having attained the age of sixteen years, Gaillard succeeded after several attempts in effecting reduction. In two of Smith's cases, and in one reported by Küster,<sup>8</sup> both shoulders were concerned.

Clippingdale<sup>9</sup> showed to the West London Medico-Chirurgical Society a child seven months of age with the head of one humerus in the axilla; the bones of the arm were all rudimentary, and the hand had only four digits. The explanation given was that the dislocation was intra-uterine, "due to sudden and irregular contractions of the uterus, the result of fright."

Flower<sup>10</sup> mentions an instance of dislocation forward, in a child only fourteen days old; the arm, it is said, had been violently pulled and twisted.

I myself saw, in 1864, the same shoulder twice dislocated forward within four months, in a little girl two years old; on both occasions the accident occurred as the child was lifted out of its cradle. Ashhurst has

<sup>1</sup> Both cases reported in the Dublin Medical Press, February 20, 1841.

<sup>2</sup> Annual of the Universal Medical Sciences, 1889, from Bull. Méd. du Nord, June, 1888.

<sup>3</sup> Northwestern Medical and Surgical Journal, August, 1871.

<sup>4</sup> American Journal of the Medical Sciences, January, 1854.

<sup>5</sup> British Medical Journal, November 19, 1881.

<sup>6</sup> On Fractures, etc., Dublin, 1854, p. 256.

<sup>7</sup> Archives Générales, August, 1840.

<sup>8</sup> Berliner Klinische Wochenschrift, January 6, 1879.

<sup>9</sup> British Medical Journal, February 2, 1889.

<sup>10</sup> Holmes's System of Surgery, 3d ed., vol. i. p. 972.

reported<sup>1</sup> a subcoracoid luxation in a girl two and a half years old, who had been swung round by the arm.

A case of spontaneous luxation of the humerus is mentioned by Keen<sup>2</sup> as occurring in a badly-nourished child aged two; it was easily reduced, and did not recur; but the bone subsequently became necrotic. Another, in a girl aged twelve, after a fever, is recorded by Sir A. Cooper.

Hamilton treated a girl of fourteen who had her humerus dislocated into the axilla by a fall on the sidewalk. Stimson<sup>3</sup> merely mentions as the cause of a subspinous dislocation "the throwing of a stone, by a boy ten years old." Another instance of this (in children) rare displacement has been reported by Chambers,<sup>4</sup> in a boy aged four years. The mechanism of its production was not known, but the position of the head of the bone was clearly made out, and the arm was shortened by an inch. Reduction was effected by extension and manipulation.

A case of compound luxation has been reported by Scott;<sup>5</sup> it occurred to a boy aged fourteen, who was thrown from a horse and dragged. The head of the humerus lay exposed on the front of the pectoralis major muscle. Reduction was effected, and the boy recovered with a useful arm.

So far as can be judged from the small number of recorded cases, it would seem that the luxation of the humerus forward is in children the most frequent form; but the great laxity of the capsule in them must be borne in mind; and my own belief is that the head of the humerus escapes first into the axilla, and then is drawn up under or in front of the coracoid process. In three cases only—Stimson's, Chambers's, and one of R. W. Smith's,—was the head noted as displaced backward.

The congenital luxations of the shoulder would appear to have been noticed as "something wrong" by the parents, and recognized by the surgeon from deformity and limitation of motion. In traumatic cases there is pain, with more or less complete loss of use of the arm, and deformity.

Dugas's test may be of much use in these cases; it consists in placing the elbow at the side, and trying to carry the hand over to the sound shoulder, which cannot be done if the head of the humerus is displaced. I am not sure, however, that in children the laxity of the ligaments may not sometimes be such as to lessen the value of this sign in them.

Reduction is usually effected without difficulty, by manipulation alone, in young children. Anæsthesia is not needed. After the age of eight or ten years there may be more resistance encountered, and it may be necessary to give ether and to make extension with the knee or the heel in the axilla.

The after-treatment consists in keeping the limb at perfect rest, which is best accomplished by binding it to the side for a few days, after which the hand and forearm may be simply supported in a sling.

<sup>1</sup> American Journal of the Medical Sciences, October, 1870.

<sup>2</sup> Toner Lecture for 1876, on the Surgical Complications and Sequelæ of Fevers.

<sup>3</sup> Op. cit., p. 241.

<sup>4</sup> College and Clinical Record, September, 1889.

<sup>5</sup> Lancet, March 4, 1834.

LUXATIONS OF THE ELBOW, like fractures of the lower part of the humerus, are very common in children. One reason of this is the great slackness of the ligaments in them; probably every one has noticed the great degree of extension and flexion of this joint which they possess, as compared with that possible to adults. Then, again, the joint is a complex one, and the bones entering into its formation are in early life smooth and rounded, acquiring their strong features only with their full development.

Either one or both bones of the forearm may be dislocated upon the humerus; in the former case the relation between the radius and ulna must, of course, be also changed. Each of the various displacements which are included under these general terms has its special mechanism. I believe, however, that in nearly all cases not only is there a stretching of the ligaments, but a twist is also impressed upon the part, so that the articular surfaces slide, as it were, around one another.

Luxation of both bones backward is by far the most frequent of these injuries. In Krönlein's tables, quoted by Stimson,<sup>1</sup> out of ninety-four cases of this kind, twenty-two were in children between one and ten years of age, and forty-four between eleven and twenty. Hamilton states that out of seventy-two cases collected by him twenty-nine were under fourteen years of age; and speaks here, but nowhere else, of one of them who was only four. I have myself never seen such an injury in a child less than six years old, nor do I know of any report of one except this mere mention.

It has occurred to me to see two cases of this kind in one family: a boy aged six, in 1878, and his brother aged ten, in 1887; in each instance the cause was a fall on the hand, and reduction was easily effected.

For the most part, the symptoms of luxation backward are distinctive: the forearm is helpless, slightly flexed, usually more or less decidedly pronated; the antero-posterior diameter of the elbow is greater than normal; the olecranon is felt and seen projecting behind the condyles of the humerus, and the finger can be pressed into a gap above it; the rounded end of the radius is below the external condyle; passive motion, flexion especially, is limited, and the distance from the bend of the elbow to the wrist is shortened. Under such circumstances, it would seem as if mistake were impossible; but swelling comes on very rapidly, and may so mask the parts as to prevent the detection of the injury. Moreover, there may be, along with the luxation, fracture of one or both condyles of the humerus, or of the coronoid process of the ulna. In 1877 I saw a boy about fourteen years old, with a backward luxation of the elbow, the radius and ulna being widely separated. No fracture could be detected; reduction was easy by extension. The account he gave was not clear, and I am at a loss to account for the condition.

Now, it is of great importance to determine not only the fact of the dis-

---

<sup>1</sup> Op. cit., p. 21.

placement of the bones, but also the question whether or not there is fracture; and hence in any case of doubt the child should be etherized, and a most careful investigation made. Occasionally reduction is at once and easily effected, with complete restoration of the normal form of the joint, as well as of its mobility. But the child may be frightened and resist; there may be so much swelling as to obscure the parts; above all, there may be a suspicion of fracture as well as luxation, in which case the prognosis and the treatment would be materially influenced. Cases are upon record in which, even in expert hands, the supposed reduction had not really been accomplished. The rule should, therefore, be absolute, that in any case of either doubt or difficulty anæsthesia is to be induced. Sometimes, even with every advantage, it is impossible to determine the exact seat of fracture; and in any such case a prudent surgeon will be very guarded in his prognosis.

As to the method of making the reduction, we should be guided by mechanical principles. The coronoid process must be disengaged from behind the lower end of the humerus; and in order to do this the forearm should be still further extended on the arm, with slight traction on the hand.<sup>1</sup> I have never seen a case in a child in which this manœuvre was not sufficient, the bones instantly slipping into place, unless there was also fracture.

Spencer<sup>2</sup> has reported the case of a boy aged ten, with luxation backward of both bones of the forearm, in which three attempts at reduction failed; an incision was made, and the olecranon removed, when a tight band was found across the back of the humerus; this was slackened and slipped over the end of the bone, after which the reduction was effected, and a good result was ultimately obtained.

Of course, when the dislocation is of long standing, it is a different matter. Hamilton mentions a boy of twelve whose elbow had been out six weeks and could not be reduced. In another case, that of a boy aged seven, the luxation dating back nine weeks, the arm being nearly straight, flexion was made, and the olecranon gave way. In still another old case, the triceps was divided and reduction then made by flexion. Although in these last two cases the bones were restored to position, the ultimate results were not altogether satisfactory as regards motion. Beck<sup>3</sup> has reported a curious case in which a boy aged seven had a backward luxation of the left elbow, which had existed seven months; while at play he had a fall, by which the adhesions were broken up, and reduction was then effected without difficulty.

---

<sup>1</sup> Some surgeons, and notably Sir A. Cooper, have advised a different method, thinking it better to flex the elbow, and to draw the hand forward with the limb in this position. The advantages of the plan mentioned in the text are so much greater, both in theory and in practice, that I think it should always be employed, and therefore have allowed it to stand alone.

<sup>2</sup> *Lancet*, November 16, 1889.

<sup>3</sup> *New York Journal of Medicine*, May, 1857.



Maisonneuve,<sup>1</sup> in the case of a boy aged fifteen, with a backward luxation of the elbow of forty-seven days' standing, succeeded in effecting reduction by upward traction upon the humerus from just below the insertion of the deltoid, and downward upon a "lac" applied directly over the olecranon, and forming a figure-of-eight around the forearm.

My own experience in old luxations of the elbow in children has been limited to cases which were beyond remedy; and I have never seen one in which there was not a probability at least that the injury had been complicated with fracture. Sometimes, in old unreduced luxations of the elbow, the condition is such as to justify a resort to complete or partial excision of the joint; the latter operation is reported by Davies-Colley<sup>2</sup> to have been practised by him in the case of a boy aged eleven, with good result.

Even when reduction has been readily and fully effected, there is not always a certainty of success. Hamilton mentions a case in which a boy aged eight, with such a history, had still a stiff joint, at a right angle, more than four years afterwards.

Malgaigne laid stress upon the possibility of *incomplete* backward luxation of the elbow, but it does not seem to call for special discussion here. He says that in old cases reduction is easier than in the complete form, mentioning a boy aged ten in whom he succeeded after the lapse of nearly four months.

I myself recently met with a case in a boy aged fourteen, who had been thrown down in playing the day before. Flexion and extension were both somewhat limited, the former especially; pronation and supination seemed normally free. On measurement, the distance from the acromion to the tip of the elbow was greater by one-fourth of an inch than in the sound limb, and the circumference of the elbow was increased half an inch. Reduction was easily effected under ether given to the first insensibility, and the motions of the joint were completely restored.

The symptoms and treatment do not vary materially from those of the complete form already described.

Other dislocations of the bones of the forearm upon the humerus have been met with,—outward, inward, and forward. As to the two former, I would suggest that they are brought about, in part at least, by the formation of the articulating surface of the humerus, by reason of which the ulna, carrying with it the radius, slides around one or other of the ridges limiting the trochlea. The lateral ligaments of the joint are put upon the stretch, when the ulna is drawn away from the humerus, and, as it goes back, the ridge in the middle of the sigmoid cavity fails to fit into the depression in the trochlea, but is applied to one or the other side of it. In other words, I think that, when both bones of the forearm suffer displace-

<sup>1</sup> Clinique Chirurgicale, tome i. p. 529.

<sup>2</sup> British Medical Journal, February 2, 1889.

ment together, the ligaments are stretched, and the ulna comes away from the trochlea; as it goes back, the natural relation fails to be restored, generally because the coronoid process slips behind the humerus, but sometimes because the ulna goes to the inner side or to the outer side of the trochlea. Hamilton mentions the case of a boy aged eight in whom the radius and ulna were displaced outward and upward (backward); firm pressure being made upon the radius from the outside, "the bones assumed suddenly the position of a backward and upward dislocation, from which position they were readily reduced to their original sockets by simple extension."

Complete luxation here is when the articular surfaces of the radius and ulna are both wholly separated from that of the humerus. I know of scarcely any instances of this kind in children, except in the backward direction. Chapel's case (forward), and some of the divergent dislocations, as, for example, when the radius slips out forward and the ulna goes backward, are complete; but for the most part there is some contact between the articular surfaces. I have never seen an instance in which there was a complete separation of both bones from the humerus, either outward or inward, in a child, but have several times treated backward luxations in which the bones had suffered outward displacement also.

Variek<sup>1</sup> has reported the case of a boy aged nine who fell from a wagon on his back, with his elbow flexed, and sustained a complete outward luxation. Reduction was effected by moderate extension, with lateral pressure, ether having been given; and perfect recovery ensued. Prewitt,<sup>2</sup> in the case of a girl aged five, who by a fall from a swing five weeks before had luxated the elbow inward, found reduction impossible.

A very remarkable case is quoted by Malgaigne from Chapel: a boy aged fifteen struck his arm roughly against a wall, and forced the whole forearm outward and forward, so that the epicondyle was behind the ulna. Reduction was effected at the second attempt, by extension and pressing the bones into place.

Sir A. Cooper<sup>3</sup> mentions the case of a boy aged eight who by a fall on the hand sustained a luxation of both bones inward. The injury was supposed to be a fracture, and was treated accordingly. A month later, on the removal of the splints, the sigmoid cavity of the ulna was found applied to the epitrochlea; flexion was limited to ninety degrees, extension to one hundred and forty-five degrees; there was very little voluntary motion, but pronation and supination could be made passively.

Dr. A. F. Stifel, of Wheeling, West Virginia, has reported to the American Medical Association a case of incomplete luxation inward of the elbow, in a girl aged three and a half years; the swelling was so great as to prevent a correct diagnosis for several days; reduction was repeatedly

---

<sup>1</sup> New York Medical Record, November 1, 1867.

<sup>2</sup> St. Louis Courier of Medicine, January, 1879.

<sup>3</sup> Op. cit., p. 465.

attempted, but without success. Dr. S. discusses at length the pathology and symptoms of this injury, which he thinks occurs more frequently than is generally supposed, its true nature often escaping recognition. He advises traction and lateral pressure for reduction.

It is impossible to imagine such displacements occurring without considerable laceration of the ligaments about the joint, and one would suppose other structures would suffer also.

A case of compound luxation, with rupture of the artery and stretching of the median nerve, in a boy aged fourteen, is reported by Ferret;<sup>1</sup> the nerve perished, and there was gangrene of some of the fingers, but a good result ultimately ensued. Malgaigne<sup>2</sup> quotes from Michaux an instance in which, in the attempt at reduction of a luxation outward and backward in a boy aged ten, the artery and nerve were both torn, and gangrene made amputation necessary.

Clutton<sup>3</sup> has recorded a case of complete compound dislocation of the elbow outward and backward, in a boy nearly thirteen years old. The bones having been reduced, drainage was made, and the anterior wound left open. The result was a complete restoration of movement.

As to the symptoms, the elbow is, of course, wider than natural, and the deformity of outline will indicate the character of the lesion.

Fergusson<sup>4</sup> says, "It is impossible to say what dislocations may not take place in this articulation. I have myself frequently seen the joint in such a disordered condition, from injuries of old date (probably luxations and fractures combined), that the most experienced anatomists have been unable to appreciate the true condition of the ends of the bones." This is especially true in the case of children. I believe that the most usual of these irregular displacements is that in which, the head of the radius slipping out from the grasp of the annular ligament, this bone starts up in front of the condyle, while the ulna goes backward. And it will readily be seen that by a slight further twist the head of the radius may pass to the outer side of the condyle. A case of this kind, in a boy of eleven years, came under my care at the Pennsylvania Hospital in 1886; reduction was easily effected. I think this is the true explanation of the two cases, in boys aged respectively thirteen and fifteen, related by Sir A. Cooper; and perhaps it is applicable in the other instances, in adults as well as in young subjects, which are upon record.

Luxation of the radius alone has been many times observed. Generally the bone goes *forward*. This lesion may be congenital, as in a case reported by Heelis,<sup>5</sup> where the bone of the left side was completely, and that of the right partially, displaced; the former was reducible on flexion, the

<sup>1</sup> Progrès Médical, May 7, 1887.

<sup>2</sup> Fractures et Luxations, tome ii. p. 152.

<sup>3</sup> Transactions of the Clinical Society of London, 1889, vol. xxii.

<sup>4</sup> Practical Surgery, 5th ed., p. 215.

<sup>5</sup> Lancet, August 7, 1886.

latter irreducible; the humeral condyles were very small, and there were evidences of defective development of the nervous system. Krackowizer<sup>1</sup> recorded a case in which such a luxation was ascribed to the operation of turning in delivery. Danyau<sup>2</sup> mentions the case of a girl aged three whose hand had been pulled upon in supination; the radius was displaced forward, and could not be reduced. He quotes Loir as having met with the lesion on both sides in the dead subject; the heads of the bones were much lessened in volume.

This luxation has been perhaps oftenest caused by careless traction on the forearm, in very young children. Collier<sup>3</sup> was, I believe, the first to report a case so produced, in a child two years and a half old, whose mother lifted it by its wrists. The lesion was thoroughly well described by Goyrand,<sup>4</sup> who assigned this cause for it. Sir A. Cooper thinks it is produced by falls on the hand, and cites an instance in point, in a boy seven years old.<sup>5</sup> Hamilton saw it in a girl aged four, who had fallen from a swing and held on by her hands. The subluxation, or incomplete form, in which the head of the radius does not wholly leave the condyle, has been recently described and discussed as a new thing by several writers.<sup>6</sup> Perhaps this is the lesion usually caused in children under five years of age by traction on the hand; but the complete displacement may also occur in them, as well as in older children. The symptoms of either are pain in the elbow; the forearm flexed to a right angle with the arm, and more or less completely pronated; passive motion limited, and the attempt at it painful; and the head of the radius felt in its abnormal situation.

Reduction, according to some, is very easily effected by supinating the hand, and pushing the head of the radius into its proper position. But we have the testimony of Hamilton, Sir A. Cooper, and Malgaigne, that the replacement is not always possible. Danyau's case, before quoted, was of this character; and many other such instances are on record. Sometimes there is a marked tendency to recurrence of the displacement.

It may be mentioned here that this luxation is apt to be accompanied with dislodgement of the ulna backward; and sometimes, as in three cases recorded by Hamilton, the latter bone is broken instead, as if the force exerted would have caused luxation but for the giving way of the bone. Such a view is more plausible in Hamilton's cases, where the fracture was in the upper third, than in one observed by Stimson,<sup>7</sup> where the fracture was at the middle of the ulna. Such associated injury does not appear to

---

<sup>1</sup> New York Journal of Medicine, March, 1857.

<sup>2</sup> Archives Générales, April, 1841.

<sup>3</sup> London Medical Gazette, September 10, 1836.

<sup>4</sup> Gazette Médicale, February 23, 1837.

<sup>5</sup> Dislocations and Fractures, p. 455.

<sup>6</sup> Lindeman, British Medical Journal, March 18, 1882, also December 5, 1885, and March 6, 1886; Sneddon, *ibid.*, April 8, 1882; James, *ibid.*, January 2, 1886; J. Hutchinson, Jr., *ibid.*, same date; Cushing, Boston Medical and Surgical Journal, January 28, 1886.

<sup>7</sup> Treatise on Dislocations, pp. 340-41.

constitute any complication in treatment of the dislocation, which is to be reduced as soon as possible; the limb is then to be kept at rest, with the elbow flexed at a right angle, and the splints elsewhere described applied to remedy the fracture.

Sir A. Cooper mentions a case in which a boy aged twelve had the radius luxated upward and outward (forward?), with fracture of the olecranon, by a severe blow. Thirteen years afterwards he had only imperfect extension and flexion of the joint; and in the latter motion the head of the radius would slip out of place.

*Luxation of the head of the radius backward* has been observed as a simple uncomplicated lesion. Hamilton mentions a case seen by him in which it was said to have been the result of convulsions when the boy was but one year old. Danyau<sup>1</sup> saw it in a boy aged eleven; it had occurred five weeks before; the elbow was semi-flexed, and the power of voluntary pronation and supination was lost; reduction was effected with difficulty.

Phillips<sup>2</sup> has recorded the case of a girl aged seventeen who had congenital luxation backward in both elbows, the heads of the radii lying behind the condyles; extension and flexion were free when the hands were semi-pronated. In another instance, reported by Pye-Smith,<sup>3</sup> there was such a congenital luxation on the left side only; the woman was one of eleven children, eight of whom had abnormal joints, imperfectly developed hands and feet, and malformed nails. As a result of such displacements, or of those due to accident in childhood, the joint undergoes changes of shape, which have been studied and described by Allan.<sup>4</sup>

This lesion has been repeatedly observed along with fracture of the inner portion of the lower end of the humerus. It seems to me that the mechanism which at once suggests itself for such an injury is the true one; that there is at the same time a twist of the hand into supination, and an abducting force, so that the trochlea and the portion of bone just above it are wrenched away by reason of the engagement of the former in the sigmoid cavity of the ulna. Should the position of the limb, the direction of the force, or the slackness of the ligaments be such as to allow the ulna to slip away from the trochlea, there would be merely a luxation backward of both bones.

*Luxation of the radius outward* has been observed in a few cases in children; it is perhaps for the most part secondary to luxation forward, although in one case quoted by Stimson<sup>5</sup> from Von Pitka it would seem to have been produced directly, a grown person treading on the elbow of a girl nine years old, who lay asleep on the floor with the arm extended in supination. The head of the bone can be recognized at the outer side of the

<sup>1</sup> Archives Générales, April, 1841.

<sup>2</sup> British Medical Journal, April 21, 1883.

<sup>3</sup> Lancet, December 8, 1883.

<sup>4</sup> Glasgow Medical Journal, July, 1880.

<sup>5</sup> Op. cit., p. 329.

humeral condyle, and reduction effected by simply pushing it back into place. Sometimes this has been found impossible, the annular ligament crumpling up, and failing to receive the head of the bone; and the dislocation has in some instances recurred very obstinately.

**Luxation of the ulna alone**, backward, has been observed in one case by Von Pitha,<sup>1</sup> a little girl aged six having the extended arm forcibly flexed at the elbow. This joint was twisted toward the ulnar side, and the prominence of the olecranon behind and the trochlea in front could be easily made out; the radial head was in place; flexion gave great pain. Reduction was effected by slightly increasing the extension until the coronoid process slipped over the trochlea.

Before leaving this subject I feel constrained to mention again the difficulties which beset the surgeon in dealing with injuries about the elbow. The various luxations which have now been discussed are not easy to recognize in practice, even in thin subjects, and when uncomplicated. Even in dissected specimens it may be hard to determine the exact character of the lesions. Upon the occurrence of injury, swelling usually comes on with great rapidity, and masks everything. Fracture may be present, and the crepitus and mobility due to it may mislead the surgeon. Hence the utmost care should be taken in examining every case, anæsthesia being almost always requisite; a guarded diagnosis and prognosis only will be given by a prudent surgeon; and it behooves us to be charitable to the utmost in judging of the results of the practice of others.

**LUXATIONS OF THE WRIST**, formerly described by surgical writers as of common occurrence, are now known to be extremely rare; the cases supposed to have been of this character having probably been fractures close to the joint. A number of the instances which have been placed on record are open to much doubt, as, for example, that of Haydon, published by Sir A. Cooper;<sup>2</sup> in which a boy aged thirteen, thrown from a horse, is said to have had one wrist luxated backward and the other forward. Here there was probably a double fracture. I shall mention only a few cases which seem to be unquestionable.

In one instance<sup>3</sup> a boy aged nine fell from a tree a distance of over thirty feet; the left wrist was dislocated backward, and was easily reduced by extension and pressure, "the patient immediately regaining the use of the joint." Roland<sup>4</sup> saw a boy about twelve years of age who by a fall had the carpus displaced forward (on the palmar surface of the radius and ulna); the hand was fixed at nearly a right angle with the forearm, and the fingers were strongly flexed. During the administration of ether the bones slipped into place. Aitken<sup>5</sup> reports the case of a boy of sixteen who sustained a

---

<sup>1</sup> Pitha and Billroth, *Deutsche Chirurgie*, Lieferung 63 b, p. 81.

<sup>2</sup> *Op. cit.*, p. 485.

<sup>3</sup> Hospital Report, *Lancet*, June 12, 1841.

<sup>4</sup> Philadelphia Medical Times, June 7, 1879.

<sup>5</sup> *Lancet*, June 11, 1887.

like injury by falling from a tree ; by traction on the hand, reduction was effected with a snap, and, although the wrist remained swollen for three months, a perfect recovery ensued. Walker<sup>1</sup> saw a dislocation backward in a boy aged sixteen, who was pushing a cask, when it slipped back, and his elbow came against another cask ; reduction was easily effected. In 1874 a boy about twelve years old was brought to my office who had a few minutes before fallen about eight feet and "twisted his hand all out of place." His comrades immediately pulled upon it, and it was reduced, when he came to me. There was certainly no fracture, and the use of the hand was restored completely. Harlyman<sup>2</sup> reports the case of a boy aged twelve who fell from a height of about two feet forward on his hand, sustaining a luxation backward of the wrist ; this was easily reduced, and a green-stick fracture of the radius was then discovered. Sherburn<sup>3</sup> has reported the case of a boy aged fourteen who fell twenty feet, and sustained a luxation backward of the wrist ; the hand was somewhat abducted and the fingers were flexed. Reduction was effected by traction in extension, with gradual flexion and pressure. Some stiffness followed.

In a true dislocation backward of the wrist, the deformity closely resembles that of fracture in that neighborhood. But, unless swelling has taken place to a very marked degree, the rounded shape of the carpal bones can be traced at the back, while in front the radius and ulna can be distinctly felt, with the concavity formed by them at their lower end. On strong extension the deformity disappears, and the joint can at once be moved as usual. Careful examination should always be made for the crepitus which would attend fracture.

Dislocation forward presents the opposite condition ; the radius and ulna can be traced to their lower termination, while the carpus projects at the palmar surface ; but the flexor tendons and the strong annular ligament are rendered extremely tense, and may hold the hand in flexion (see Roland's case, above).

One indication is perfectly clear in all these cases,—viz., that strong extension is to be made upon the hand. If this completely corrects the deformity, the movements of the joint should be tested, and then, if there is no crepitus, the parts should be placed at rest on a properly-padded splint. Swelling and tenderness may persist for a few days, and in that case should be treated by wet dressings. Leeches may be applied if there is decided inflammation.

*Lateral luxations* of the wrist are described by writers, but are probably always pathological, the result of previous disease of the joint, and need not be dwelt upon here.

*Luxations of the lower radio-ulnar articulation* have been described, but there is very little known about them. There may be a diastasis of the

---

<sup>1</sup> Lancet, September 10, 1887.

<sup>2</sup> *Ibid.*, November 5, 1887.

<sup>3</sup> *Ibid.*, May 18, 1889.

one bone from the other, the triangular cartilage going with the radius. It seems to me that these injuries would be more correctly designated as partial luxations of the wrist, the hand being forced into extreme pronation or supination and at the same time adducted or abducted. I do not know that such a case has ever occurred to me.

Sneddon, in the article before quoted,<sup>1</sup> expresses the opinion that the injury supposed to be sublucation forward of the head of the radius may be in fact a displacement at the wrist; but I must confess my inability to understand his view.

*Compound luxations* of the wrist are very serious injuries, and may require resection or even amputation; although it should be remembered that in children the reparative powers are much greater than in adults. No general rules can be laid down for the treatment of such cases, which call for the utmost skill and judgment on the part of the surgeon.

**LUXATION OF THE METACARPUS** from the carpus has been seen by Stimson in a boy aged fifteen, who had fallen forty feet and sustained other severe injuries. The hand was in extension, and the metacarpal bones of all the fingers were tilted into the palm, that of the thumb being slightly if at all displaced. Reduction was easily effected, and the ultimate result was good.

**LUXATIONS OF THE PHALANGES** have been observed in children. Hamilton mentions several cases in which the first phalanx of the thumb was displaced backward. Simpson<sup>2</sup> reports a case of dislocation of the same bone forward in a boy aged nine, by a fall on the hand; the head of the bone was grasped between the tendons of the flexor brevis, but was reduced under chloroform.

The symptoms are characteristic, and the indications clear.

Symonds<sup>3</sup> has reported two instances of dislocation backward of the first phalanx of the index finger, in boys aged nine; one was by a blow with a cricket-ball, the other by a fall. In each case he opened the joint and divided the retaining bands, with good result. It may be noted also that in each case the investing cartilage was fissured into the bone.

A number of additional cases have been recently reported by Dr. W. H. Battle.<sup>4</sup>

Compound luxations of the thumb- or finger-joints are not uncommonly met with, the end of the displaced bone forcing its way through the skin. Occasionally resection, or even amputation, may be indicated; but in the vast majority of instances, in children, if anæsthesia is induced and the bone put into place, the wound being made thoroughly aseptic, the result obtained is astonishingly good. At all events the attempt should be made, since even if it fails the delay will do no harm.

---

<sup>1</sup> British Medical Journal, April 8, 1882.

<sup>2</sup> Lancet, February 11, 1888.

<sup>3</sup> British Medical Journal, March 17, 1888.

<sup>4</sup> Annals of Surgery, 1889.



LUXATIONS OF THE HIP-JOINT rank next in frequency, in children, to those of the elbow. They may occur congenitally, either one or both joints being affected; but in such cases there is malformation, often if not always due to central nerve-lesion, and a special article will be devoted to their discussion.

Hamilton mentions a man named Warren, who had the power of luxating nearly all his joints at will, and says that this began in his infancy, by frequent accidental and spontaneous displacements of the hip. Two children of this man, a boy and a girl, had the same tendency to accidental dislocations of the hip. Stanley<sup>1</sup> saw a stout, muscular boy aged eighteen, who could displace the head of either femur upon the dorsum ilii and return it to the acetabulum again; this was no doubt a condition which had existed from early life.

Luxation of the hip may take place upward and backward, the head of the femur lodging upon the dorsum ilii; and this, in children as in adults, is most frequently the case. Or the head of the femur may go downward and backward into the ischiatic notch, or downward and forward into the thyroid foramen, or upward and forward, resting on the pubes or in that vicinity. An accurate idea of the mechanism in any special case in a child is rarely attainable, and, so far as my knowledge goes, the only dissections of recently-luxated hips have been in adults. From the anatomical conditions of the joint in childhood, it seems to me probable that the head of the bone may pass out of the socket directly, and not that, according to the theory held by H. Morris<sup>2</sup> and others, the rent in the capsular ligament is always at its lower part. Mr. Morris has, however, reported<sup>3</sup> the case of a boy aged seven, with a dorsal luxation produced when the limb was in abduction; so that here the bone would seem to have gone out below and in front, subsequently slipping up upon the dorsum.

A number of instances are upon record in which luxation of the hip has occurred without known cause, in children who have been the subjects of fever or of rheumatism. Stanley<sup>4</sup> gives an account of one such in a boy aged fourteen, who had had rheumatic fever, the hips having suffered; here the limb was everted, and shortened three inches and a half; the head of the bone was plainly felt under the glutei muscles. In all the other cases the luxation has presented the usual features, to be presently mentioned, of the dorsal luxation. Stanley mentions another case, in a girl aged fourteen, who, however, had a fall on the hip about six weeks before the displacement was noticed; reduction occurred spontaneously, but the bone was again luxated, and so remained. Verneuil,<sup>5</sup> in the case of a girl aged ten, with rheumatism following typhoid fever, reduced a dorsal luxation of the

<sup>1</sup> Medico-Chirurgical Transactions, 1841, vol. xxiv. p. 142.

<sup>2</sup> Holmes's System of Surgery, 3d ed., vol. i. p. 1057.

<sup>3</sup> Medico-Chirurgical Transactions, 1877, vol. lx. p. 174.

<sup>4</sup> *Ibid.*, 1841, vol. xxiv. p. 132.

<sup>5</sup> Bulletin de la Société de Chirurgie, October 31, 1883.

femur on the sixth day; a good result was expected when the report was made. Brown<sup>1</sup> reports the case of a girl aged eight, who had had an attack of rheumatism lasting three months and a half; she got up June 15, and a spontaneous dorsal luxation of the right femur was detected. She came under Dr. B.'s care October 4, when he accomplished reduction by manipulation. Langenbeck had one in a boy aged eight, who had had typhus fever; two months later, efforts at reduction failed. In several such instances excision of the head of the bone has been resorted to; as, for example, by Rawdon,<sup>2</sup> in a girl aged eight, and by Adams,<sup>3</sup> in a boy aged eleven.

No doubt in some of these cases there has been so much inflammation as to have given rise to adhesions of the head of the bone to the neighboring parts. Hayward<sup>4</sup> mentions a boy aged eight whose femur became displaced on the dorsum nearly four months after typhoid fever, and another aged ten in whom the same lesion occurred just as he was recovering from scarlatina. In both instances the dislocation was permanent. A like result is reported by Franks<sup>5</sup> in the case of a girl of fifteen, the luxation having followed acute rheumatism.

Gibney<sup>6</sup> has recorded an interesting case of spontaneous dorsal dislocation of the hip, repeatedly recurring, in a girl aged nine, under treatment for acute disease of the joint at an early stage. At the time of the report, it is said, there was "no deformity, child free from pain, and case in every way doing well." Hilton<sup>7</sup> mentions three cases: a boy aged five and a girl aged seven, in both of whom ankylosis ensued; and a girl aged fourteen, in whom the left femur was luxated on the dorsum and the right into the foramen ovale, both being reduced with a good result. Ormerod<sup>8</sup> relates the case of a girl aged six, who had hurt her hip by a fall, and in whom the head of the femur became gradually displaced on the dorsum ilii, where it contracted firm adhesions; the ordinary symptoms of hip-joint disease would seem to have been absent.

The degree of violence producing traumatic luxations of the hip in children has varied greatly in the different cases on record; sometimes it is very severe, as a fall from a height, the crushing weight of a heavy door (in two instances), or the passage of a wagon-wheel over the hip. Sometimes a mere fall on the ground has been assigned as the cause.

Dorsal luxation is said to have occurred before the age of one year in a girl, seen by Gross when she was seven years old; the abnormal position

---

<sup>1</sup> Boston Medical and Surgical Journal, September 29, 1870.

<sup>2</sup> Liverpool Medico-Chirurgical Journal, January, 1882.

<sup>3</sup> British Medical Journal, November 1, 1884.

<sup>4</sup> Surgical Reports, etc., Boston, 1855.

<sup>5</sup> Lancet, July 7, 1883.

<sup>6</sup> American Journal of the Medical Sciences, October, 1879.

<sup>7</sup> On Rest and Pain, London, 1877.

<sup>8</sup> Clinical Collections, etc., p. 116.

of the head of the bone was then clearly to be perceived. South<sup>1</sup> states that in the case of a child "close upon one year old" reduction was effected by Stanley. Tracy<sup>2</sup> saw a boy aged twenty-two months in whom the lesion was caused by a fall from his nurse's arms; the bone was easily restored, with the aid of anæsthesia. The youngest case I have myself treated was a girl aged three and a half, brought to the Episcopal Hospital in 1881; reduction was easily accomplished by manipulation.

The symptoms of this injury are adduction of the knee, which is drawn up over the opposite thigh, the foot being more or less closely applied to the instep of the other, and the whole limb seeming to be shortened; motion is limited and painful; the trochanter projects, and is higher than it should be, and the head of the bone can be felt as a hard mass above and behind the position of the acetabulum; a hollow is perceived beneath the sartorius muscle. Nélaton's line, from the anterior superior spine of the ilium to the front of the tuber ischii, crosses the trochanter below its tip, which it should just touch.

It would seem as if the diagnosis ought to present no great difficulty. Yet Norris<sup>3</sup> has reported a case in which a boy of twelve, at an early stage of disease of the joint, was supposed to have a dislocation, and was subjected to severe suffering for its reduction; and another in which a boy who had a dislocation was treated for some months with the idea that the neck of the bone was fractured.

Reduction is to be effected by manipulation, which should be very gentle, an anæsthetic having been given. The chief obstacle to be overcome is the resistance of the ilio-femoral ligament. Muscular contraction has very little to do with the matter. There is a rent in the capsule, through which the head of the bone has escaped, and through which it must go back unless such violence is used as to tear off any portion of the capsule which is in the way. We should never forget, in dealing with these cases in children, the delicacy of their tissues as compared with those of adults. The best rule is to flex the thigh upon the abdomen and the knee upon the thigh, next with moderate traction to adduct the limb, and then to rotate it outward into abduction. Pressure may at the same time be made upon the head of the bone by the fingers of an assistant; but this is not often called for. Sutton,<sup>4</sup> in the case of a boy eight years old, used a roll of cloth as a fulcrum in the groin, the limb being then flexed upward and rotated outward, with perfect success.

The head of the bone should be allowed to follow its easiest course; and the surgeon should never forget that the leverage exerted through the length of the femur is very great, so that he may by undue force cause a fracture. Such an accident, in the case of a boy aged fifteen, is recorded

<sup>1</sup> Lancet, June 21, 1851.

<sup>2</sup> Toledo Medical and Surgical Journal, July, 1880.

<sup>3</sup> American Journal of the Medical Sciences, February, 1840.

<sup>4</sup> Western Journal of Medicine and Surgery, September, 1868.

by Hamilton. Under the old plan of forcible extension by means of pulleys, there was perhaps even less danger of this, since there was less likely to be a twist impressed upon the bone; yet it did sometimes occur, as in one case under the care of Drs. Harris and Randolph,<sup>1</sup> in a boy aged twelve, and in another, that of a boy aged fourteen, related by Sir A. Cooper.<sup>2</sup>

An anæsthetic is not always indispensable. Ashhurst<sup>3</sup> has reported the case of a boy aged eight, with a dorsal luxation produced an hour before by direct violence, in whom manipulation was entirely successful, without ether.

Reduction is, however, not always easy, or even practicable. Hamilton saw a German aged nineteen who at ten years of age had a dorsal dislocation which Chelius the next day failed to reduce, and five or six later attempts by the same eminent surgeon were equally fruitless.

Reduction having been effected, it is, as a general rule, needful only to tie or bandage the little patient's knees together, and to keep him in bed for a few days, until all soreness of the parts has subsided. In one case, reported by Farrant,<sup>4</sup> a boy seven years of age sustained a dorsal luxation by a fall, another boy falling upon him; the bone was easily reduced by manipulation, and it is stated that the child "was running about at the end of six weeks." No details are given, but the recovery would seem to have been unusually slow, if there was no inflammation of the joint. Should inflammation ensue, it is to be treated on general principles. I know of no instances in which strumous abscess has followed an injury of this kind, although it has been spoken of<sup>5</sup> as a possible consequence, to be guarded against by absolute and long-continued rest. Gibney, in the case before quoted, found a carefully-fitted splint, made of Manilla paper stiffened with glue, effectual in overcoming the tendency to recurrence.

For one reason or another, it sometimes happens that these luxations are not reduced immediately after their occurrence. Hamilton mentions a case of Fanning's, in a girl aged two and a half years, and South<sup>6</sup> one in a girl aged six, in each of which the bone was replaced after ten days. Bigelow, in a girl three and a half years old, whose hip had been twelve days out, succeeded by manipulation, aided by manual pressure on the head of the bone. Anderson,<sup>7</sup> of Leith, in 1772, reduced by manipulation the hip of a boy aged eight, on the nineteenth day. Hilton,<sup>8</sup> in a boy aged five, made reduction by extension, one month after the receipt of the injury. Gibney (*loc. cit.*) succeeded in the case of a boy aged four, injured six weeks

<sup>1</sup> Gibson's Surgery, vol. i. p. 363.

<sup>2</sup> Dislocations and Fractures of Joints, p. 55.

<sup>3</sup> American Journal of the Medical Sciences, October, 1870.

<sup>4</sup> Lancet, October 12, 1889.

<sup>5</sup> Bulletin de Thérapeutique, 1848, p. 206.

<sup>6</sup> Lancet, June 21, 1851.

<sup>7</sup> Medical and Philosophical Commentaries, Amer. ed., 1793, p. 262.

<sup>8</sup> Lancet, March 12, 1853.

PROFOUND and LACERATED in that it is a jagged line like the lines of several wounds. Foreman mentions that in a similar case aged six years by a fall over a wire became paralysed and sustained a lower dislocation the pulleys were entire and the condition "restored" but it is said that "the affected artery appeared to have become obliterated."

I believe the fracture in Lehigh's case to be the subject of record in a similar fracture noted above and in the hip and successful reduction. There are also two cases reported in which reduction was attained & more been effected with a cast than after the operation and in some in a propped manner. The fracture in some of these cases was comminuted and the artery fractured. The above cases are the subject of the appended.

Fracture of the neck of the femur which has been dislocated and the bone after unsuccessful attempts at replacement crossed the head of the bone with a thin lamina of white fibrous membrane that in 1866 Dr. Deane having under the age of four years old with a lower dislocation of the femur fracture extending inside the capsule and divided the ligamentum ligamentum. He then reduced the head of the bone which however resulted in an abscess and the patient died some months later. The final issue of the case is not stated.

The case of the fracture of the neck of the femur of the hip-joint is not infrequently a subject of complaint with these cases. Deegan records a striking instance of the kind in a boy thirteen years of age who had a lower dislocation of the femur in that situation the reduction of which was followed by suppuration and the formation of abscess. It then came out that the fracture was a comminuted one.

Consequently it may be said that fracture of a comminuted with fracture of the neck of the femur is not infrequently the result of this kind in a boy thirteen years of age. The fracture being in the middle of the bone the fibrous membrane in the neck and when it was "some months" were made a fracture of the neck of the femur and that was the attachment and the bone of the neck and the present day management would of course be such as to give the chance of success would be much greater.

When the head of the femur is displaced and the *capsula intact* the reduction is not difficult. The bone is held in a firm position over the shoulder and the patient is held in a position instead of projecting as in the case of a fracture of the neck of the femur. The head of the bone is only displaced a few inches from its position. When the eye is not adopted the head of the femur is held in place by the finger and the return of the bone to its position is the same as in the case of a fracture of the neck of the femur. The case was that of a boy thirteen years of age who had a fracture of the neck of the femur.

The same is the case in the case of the fracture of the neck of the hip-

luxations that can be given here to the esser of Bugelew "to the Hip" and to works on general surgery in which Bugelew's views are recommended.

Reduction is effected by a manipulative motion precisely the same as in the dorsal luxation, the swing of articulation is less or according to the lower position of the head of the neck, which is nearer the articulation. Sometimes the effect is similar to change the position of a luxated joint, dorsal luxation, and what again in various cases success may be obtained by lifting the head of the patient upwards, in the same manner making slight extension.

Some cases that the younger I saw in a case of young children in a boy aged five years the child's father by straddling him on his arms and turned him on the sound side he then effected reduction by turning him with slight rotation outward, at the same time raising the knee. Various positions I saw in various cases and also that when one of the limbs is pulled out of the socket, luxation of the head of the humerus into the upper and lower part of the scapular notch. Manual extension was made by Mr. Sumner for two minutes when the bone resumed its place and remained there. Several times I met to reduce a luxation of the head of the humerus by occurrence of a fall in turning it in one place than another in the case of a boy twelve years of age who by a fall from a tree, a small tree, downwards had sustained a severe luxation of the humerus downwards, which by manipulation, but twice, the pulley was first used in this place; removed that of manipulation was successful.

Luxations of the head of the humerus into the scapular notch, the scapular notch have been repeatedly reported in children. I saw only one in a boy only six months old, the child's legs were drawn up, the child was held and was raised by the lifting of the head of the child's head. Extension was refused, it was not signified, months ago I met a case of the same kind from the nurse's arms the child's legs being very contracted. Fractures of the humerus three cases two seen by myself and a third reported by V. Green, in which the head of the humerus was not retained, it was upward, resting in the scapular notch, but was afterwards retained, but in the child's the displacement could not be retained.

The symptoms are now as follows and beginning of the limb distending of the arm, the pressure of the head of the bone in the scapular notch, there is also tenderness to feel the head of the bone, it is not to reduce the bone, motions of the thigh.

Reduction is effected by raising the limb still upwards, upwards, it is to feel the thigh of the shoulder, head bringing it upwards, and covering it

Medical Register, London, 1848, p. 128  
 The Lancet, 1848, p. 4  
 Medical Register, London, 1848, p. 128  
 The Lancet, 1848, p. 4  
 The Lancet, 1848, p. 4  
 The Lancet, 1848, p. 4

again in adduction, at the same time making slight traction and rotation inward. Hey<sup>1</sup> has recorded the case of a boy "whose thigh was reduced while he sat upright, and astride of the bedpost." From the other cases given along with this, it appears that extension and rotation were used, the bedpost serving as a fulcrum.

The replacement is sometimes very easy. Bryant says that in a girl of fourteen, who came under his care, the head of the bone slipped into the socket on simple flexion of the limb for the purpose of making the diagnosis. Ashhurst,<sup>2</sup> in the case of a boy ten years old, reduced without anaesthesia a thyroid luxation of several days' standing. Fayrer<sup>3</sup> reduced one in a Hindoo boy aged six, by manipulation.

Occasionally more difficulty has been encountered, especially under the old methods. Ormerod<sup>4</sup> cites a case in a boy aged five, under the care of Mr. Vincent, in which the head of the bone was supposed to be in the thyroid foramen. There was eversion of the foot, and serious interference with the circulation. Extension was tried without effect until the thigh was well adducted, when the head of the bone slipped into place at once.

Sir A. Cooper gives a rather vague account of the case of a boy sixteen years old, the subject of thyroid luxation, in whom, during efforts at reduction by "extension of the superior part of the thigh perpendicularly," the head of the bone passed into the sciatic notch, where it remained. Hamilton refers to the possibility of such a change during manipulation.

Williams<sup>5</sup> has reported the case of a boy eight or nine years old, who came under his care five months after he had sustained a luxation of the left hip, probably thyroid. Reduction was effected, but there was great difficulty in preventing the recurrence of the displacement, until a block of gutta percha was shaped so as to embrace both hips.

In the Warren Museum<sup>6</sup> there is a photograph of a little girl six years old, who had a thyroid dislocation of four years' standing. The hip and knee were strongly flexed, and the limb everted, wasted, and useless. An attempt was made at reduction, the rectus femoris muscle and fascia having been divided; but a partial fracture at the middle of the femur resulted. This united well, and "by the use of extension and other mechanical means" the condition of the limb was greatly improved.

Cooke<sup>7</sup> has reported the case of a boy aged nine, who got his right leg in a hole, his knees being wide apart; the result was a thyroid luxation, and a green-stick fracture just below the trochanters; reduction was effected, and the fracture set, the boy making a good recovery.

---

<sup>1</sup> Practical Observations in Surgery, p. 204.

<sup>2</sup> American Journal of the Medical Sciences, October, 1870.

<sup>3</sup> Op. cit., p. 250.

<sup>4</sup> Clinical Collections and Observations in Surgery, p. 41.

<sup>5</sup> Lancet, June 21, 1862.

<sup>6</sup> Catalogue, p. 211.

<sup>7</sup> Lancet, January 9, 1864.

Compound luxation of the head of the femur upon the thyroid foramen, in a boy aged twelve, has been reported by Woodward.<sup>1</sup> The boy was caught and rolled over and over under a moving car; the bone projected out over the scrotum, and was entirely denuded. Very little bleeding took place. Other severe injuries were sustained, and death ensued from shock in about five hours. Another fatal case, in a boy aged fourteen, is quoted by Stimson from Macouchy; I have not access to the original account.

Sometimes the head of the femur is displaced forward and upward. In a boy aged nine, whose case is reported by Barker,<sup>2</sup> it rested just above the acetabulum and below the inferior spine of the ilium; the trochanter was turned backward toward the sciatic notch; the limb was abducted and somewhat everted. Reduction was effected by the usual manipulation, but with rotation inward. The boy had fallen while trying to jump on the back of another boy; he walked about for six days before coming under treatment. I have lately had in my wards at the Pennsylvania Hospital a young man of twenty-three, who at the age of ten fell from a trapeze, and sustained an infra-spinous luxation of the left femur, which still remains unreduced. There is neither inversion nor eversion of the foot; the limb is shortened about an inch, and atrophied; and the acetabulum, which can be felt, seems to have been filled up by bony or fibrous deposit.

Erichsen mentions that he saw a luxation of the head of the femur on the pubes, in a child eighteen months old; but gives no further details. Bryant<sup>3</sup> says that he saw his colleague Mr. Birkett "reduce, with the greatest facility, a dislocation of the head of the femur on the ramus of the pubes in a boy aged twelve, when the femur was broken below the trochanter; the bone slipping into place on the application of gentle, well-directed force."

An extraordinary case has been reported by Scriba,<sup>4</sup> in which a boy thirteen years old was knocked down backward as he stood with his left foot far back, and his legs wide apart. The head of the femur was sunk into the iliac fossa beneath the vessels and nerve, the cervix resting on the edge of the pubes. Of course the head of the bone had to be lifted out of its position and brought down in front of the pelvis, when it was reduced by the usual manipulations, with extension.

LUXATIONS OF THE KNEE-JOINT, rare in adults, are still more so in children. We do indeed, as a result of degenerative inflammation of the joint, often find the relations of the tibia to the femoral condyles more or less changed; but such displacements may be best considered in connection with the joint-diseases to which they are due.

Cases of congenital luxation—or, perhaps it would be more correct to

<sup>1</sup> Boston Medical and Surgical Journal, February 8, 1883.

<sup>2</sup> Lancet, September 29, 1877.

<sup>3</sup> Manual for the Practice of Surgery, 2d Amer. ed., p. 761.

<sup>4</sup> Centralblatt für Chirurgie, October 25, 1879.



say, of abnormal mobility—have been recorded by Wutzer,<sup>1</sup> by Kleeberg,<sup>2</sup> by Gueniot,<sup>3</sup> and by Barth.<sup>4</sup> In Wutzer's case, as in Barth's, and in one seen by Hamilton, the hips also were abnormally movable; in the former the patellæ were absent in front, but there were bodies at the back of the joints, firmly attached to the femora, which were thought perhaps to be their rudiments, misplaced. Gueniot reported two cases, and quoted seven others; in the discussion the propriety of the term "luxations" as applied to them was questioned by Lannelongue and Séc. The abnormality consisted here, as in a case reported by Bard<sup>5</sup> and in another by Youmans,<sup>6</sup> in a flexion forward, or more properly an excessive extension, of the leg on the thigh. In Youmans's case the patella was smaller than that of the sound limb.

Hamilton records a curious case in which a boy ten years old was struck on "the top of his knee" by the head of a playmate, with the effect, it would seem, of forcing the condyles of the femur backward; the luxation is said to have been only partial, and was easily reduced by extension and pressure; it was followed by violent inflammation, but eight weeks afterwards "the motions of the joint were nearly restored."

Bulteel<sup>7</sup> met with a case of rotation of the tibia outward and forward, so that the toes were everted, in a boy twelve years old, who received the injury while "skylarking" with a friend; the knee was semi-flexed, and was easily reduced by flexing it completely; no inflammation ensued.

Bagnall-Oakley<sup>8</sup> has reported his examination of a man aged seventy, who at the age of nine months had been let fall from his aunt's arms; either by this violence or by the resulting inflammation his left tibia was luxated backward on the femur, with which it had formed a false (new?) joint; he had always had full use of the limb, and flexion of the knee to perhaps fifteen degrees.

The alteration in the shape of the part, the limitation of motion, sometimes the position of the foot, together with the history when attainable, should prevent any mistake in diagnosis.

No very great displacement can occur without tearing of the lateral, and perhaps of the crucial, ligaments; and the ensuing inflammation may be such as to involve the loss of motion in the joint, or even graver results. Hence a guarded prognosis will always be given in such a case by a prudent surgeon.

As to the treatment, no definite rule can be laid down. The essential points are to restore the normal relation of the bones, and to prevent or allay inflammation by suitable measures.

<sup>1</sup> Schmidt's Jahrbuch, Sept. 24, 1836, from Müller's Archiv, 1835.

<sup>2</sup> Archives Générales, June, 1838, from Hamburger Zeitschrift für Ges. Medicin.

<sup>3</sup> Bull. et Mém. de la Société de Chirurgie, 1880.

<sup>4</sup> Archiv für Klin. Chirurgie, 1884.

<sup>5</sup> Boston Med. and Surg. Journal, Nov. 26, 1834.

<sup>6</sup> Ibid., Oct. 25, 1860.

<sup>7</sup> British Medical Journal, Jan. 8, 1887.

<sup>8</sup> Lancet, Jan. 14, 1882.

Compound luxation of the knee-joint is an accident of the greatest gravity. Yet Forster<sup>1</sup> gives the following account of a case which occurred in a child five years old. "So serious was the injury that amputation was decided on; but the boy was too ill to bear the operation. The dislocated bone, therefore, was reduced; in time, perfect ankylosis occurred, and the child recovered, with a stiff joint."

Stimson mentions a case in which "a boy eleven years old suffered a compound dislocation by having his leg caught between the spokes of a wagon-wheel;" but he does not refer to it further.

The *patella* may be luxated by violence, or by muscular action, or by both combined; the mechanism can rarely be determined with accuracy. Such displacements have been repeatedly noted as congenital, or as the result of disease.

By far the most usual form of this lesion is that in which the bone passes outward, slipping over the front of the outer condyle of the femur. Or it may be rotated upon its axis, so as to rest upon its inner edge.

One of my own children, at the age of nine, was thrown down while playing, and could not rise; I found him with his left knee flexed at a right angle, immovable, and the *patella* resting on the outer condyle; in the act of inhaling ether he struggled, and the bone slipped into place. Bradner<sup>2</sup> has recorded a very similar case, also in a boy aged nine; the *patella* was "set up on its inner edge;" the knee was slightly flexed; reduction was effected by raising the foot and depressing the knee, which was thus over-extended.

Sometimes loss of power, by injury, of the *vastus internus* allows the *vastus externus* to pull the *patella* outward, as in a boy aged eleven, of whose knee there is a cast in the Warren Museum.<sup>3</sup> Here the dislocation was permanent. In another instance, reported by Roux,<sup>4</sup> in a girl aged thirteen, it was due to rupture of the aponeurosis at the inner side of the joint; it was habitually recurrent, and was cured by dividing the *vastus externus*, and by shifting the attachment of the ligament of the *patella* toward the inner side of the tibia. Golding-Bird<sup>5</sup> has recorded a case in which the *vastus internus* seemed to have been paralyzed by a fall, in a girl aged eleven. Godlee referred to another case in a boy aged six.

Cases in which this luxation was due to infantile paralysis have been reported by Pitts<sup>6</sup> and Allingham.<sup>6</sup> Lannelongue<sup>7</sup> and Prewitt<sup>8</sup> have met with instances in which it was congenital. In Prewitt's case both *patellæ* were above and at the outer side of the outer condyle of the femur, and the toes were webbed.

**Luxation of the semilunar cartilage** has been observed in a few cases

<sup>1</sup> Surgical Diseases of Children, p. 252.

<sup>2</sup> New York Medical Record, January 20, 1877.

<sup>3</sup> Catalogue, p. 212.

<sup>4</sup> Annual of the Universal Medical Sciences, 1889, from *Revue de Chirurgie*.

<sup>5</sup> British Medical Journal, Nov. 1, 1884.

<sup>6</sup> *Ibid.*, Feb. 2, 1889.

<sup>7</sup> Bull. et Mém. de la Société de Chirurgie de Paris, April 7, 1880.

<sup>8</sup> St. Louis Courier of Medicine, April, 1882.

in children; but it presents no special features in them, and need not be discussed here.

**Luxation of the head of the fibula backward** is reported by Richardson<sup>1</sup> in a boy aged nine, who fell from a fence, striking the knee; it was easily reduced, and kept in place by a bandage. Oldright<sup>2</sup> saw a case in a boy two years old, who fell from a chair; at the time of the report, the bone could not be kept in place. Another instance in a child sixteen months old, by direct violence, is mentioned by Rosenberry;<sup>3</sup> but no details are given.

A mistake in diagnosis can hardly be made in a case of this kind. An important indication in the treatment would seem to be the fastening of the foot in inversion, so as to get the leverage of the whole bone to keep the upper end in place.

**LUXATION OF THE ANKLE** has been compound in all the cases known to me in children. Sir Astley Cooper cites two cases, in boys aged thirteen years, one seen by Ormond and one by himself; and Parrott<sup>4</sup> has reported one in a boy aged eleven. In all it was the result of great violence, and the necessity of amputation seemed imminent. In Ormond's case, although reduction was effected, the external malleolus and "a broad portion of the articulating surface of the tibia" exfoliated. In Sir A. Cooper's case the end of the fibula was broken off; it was removed, and half an inch of the lower extremity of the tibia was sawn off, before reduction could be made. A good result was, however, obtained in each instance. Bryant says that he treated a boy aged twelve in whom both the bones of the leg protruded through the wound, which was washed, the luxation reduced, and "a sound recovery ensued, with a movable joint."

Amputation has been unavoidable in the few cases of this kind which have come under my own care.

**LUXATION OF THE BONES OF THE FOOT** is extremely rare in young subjects. Liston<sup>5</sup> mentions the case of a boy aged fourteen, who fell a distance of forty feet, striking on the end of his foot; the scaphoid and cuboid bones were forced upward out of place, and could not be reduced. He mentions another boy, also fourteen years old, who by a fall from a horse sustained a compound luxation of the distal end of the metatarsal bone of the great toe, breaking it off; it was removed, and he made a good recovery. I have recently had in the Pennsylvania Hospital a boy twelve years old, who was caught under a street-car; the left foot was strongly inverted, and it was found that the scaphoid bone was partially displaced upward; reduction was effected with difficulty, and could only be maintained by keeping the leg and foot bandaged so as to force the latter outward. Complete recovery ensued.

<sup>1</sup> American Journal of the Medical Sciences, April, 1863.

<sup>2</sup> Canadian Journal of Medical Science, March, 1881.

<sup>3</sup> Medical and Surgical Reporter, Sept. 3, 1887.

<sup>4</sup> British Medical Journal, July 24, 1886.

<sup>5</sup> Practical Surgery, p. 137.

# SYNOVITIS—ARTHRO-MENINGITIS.

By A. J. STEELE, M.D.

---

THE synovial membrane occupies anatomically a middle ground between the serous and the mucous membranes. It is exceedingly delicate, and may not, like the capsule of the kidney, for example, be peeled off from its attached surface,—is not a firm individual structure, but a mere covering for the ligamentous structures and tendinous expansions surrounding the articulation, its free surface looking towards the interior of the joint. As, however, it passes from one tissue to another it retains its peculiarity,—namely, connective tissue containing numerous vessels and nerves, with a free surface of irregularly branched connective-tissue corpuscles, here and there collected in patches presenting the appearance and, quite likely, partaking of the true character of endothelium. The cells of this endothelial layer are held together by an albuminous ground-substance.

Physiologically there is a resemblance to the serous membranes in the secretion of a lubricating fluid—synovia—to diminish friction between two movable surfaces. A similarity is also observed in these membranes in their alike rapid response to irritation, resulting in an inflammation, formerly dreaded by the surgeon, but now, under antiseptic precautions, little feared.

The synovial membrane is a tissue of high vitality, and, on account of its great vascularity, is more prone to inflammation, to intense reaction from slight irritants, than the other joint-structures. It is sensitive to disturbing causes, whether injury received from without, or poisons or irritants brought to it by the blood. All cases of inflammation of this membrane do not run the same course: they differ in degree and are attended with different results. These differences depend upon the severity or virulence of the disturbing cause, as also upon the condition of the general system,—the activity of the seed and the character of the soil.

The degree of inflammation and its results determine the name that is applied to the individual case or to the class of cases. Thus, with the inflammation low and attended simply with an increase in the synovia or serum within the joint, it is designated *simple synovitis* or *sero-synovitis*; with a more intense inflammation present, so that corpuscles are thrown off, leucocytes and endothelial cells, rendering the increased synovia turbid, pus-like,

it is termed *purulent* or *catarrhal synovitis*. This is yet a surface inflammation; but, the action becoming still more intense, involving not only the synovial but also the subsynovial and perisynovial structures, so that pus comes from the deep tissues, and attended with a real disintegration, it is termed *suppurative synovitis*; which going on unchecked draws into the destructive process other structures of the joint,—cartilage, bone, ligament,—and thus becomes a veritable *arthritis (panarthritis)*. On the other hand, there may result a new formation of tissue, *hyperplastic synovitis*, and a *fungous synovitis*,—*strumous* of some authors, *tuberculous* of others.

It is pertinent to inquire here if all these forms of joint-trouble are found in the young. While replying in the affirmative, it may be observed, in addition, that there is a difference between the articular inflammations of adults and those of children. In the former the inflammation tends to remain localized in the tissue first affected, and to retain its essential pathological character; whereas in the latter it tends to spread to other structures or to assume a different character. For example, a simple synovitis in the adult, even though severe and assuming great dimensions, remains the same original process; whereas in the child it may rapidly disappear, under proper treatment, or may take on a hyperplastic form, or may change to a fungoid inflammation gradually spreading to the other joint-tissues. The cause of this difference is to be found in the rapid tissue-change of childhood peculiar to growth, in the greater plasticity of tissue, and in the proneness of local disturbances to be modified and affected by general or constitutional conditions and taints. The adult's tissues are fixed, resistive; the child's, rapidly changing, vulnerable.

An arthritis does not find a starting-point in disease of the cartilage or ligament: it begins in the membrane or in the bone. Childhood is prone to osteitic inflammation, especially in the joint-ends: such cases do not concern us here except so far as the membrane becomes secondarily affected: then the clinical features run a common course, which will be duly considered farther on.

#### PATHOLOGY.

In *simple (sero-) synovitis* the membrane becomes congested and cedematous, and the fimbriae swollen, blood extravasations occur here and there, and the contrast becomes marked between the bright red of the membrane and the pearly white of the cartilage. Leucocytes escape and reach the interior of the joint, serum is poured out, or, if the action is intense, plastic exudation takes place. The endothelial cells multiply, and are cast loose into the joint even before they are fully developed.

The synovial fluid is increased in amount and becomes greatly diluted with serum; from clear it changes to light yellow and red, and is viscid and sticky. A slight mixture of cell-elements, endothelial cells and leucocytes, and fibrin-flakes, is found. If the process now retrogrades, the cell-proliferation ceases, the serum is absorbed, the enlarged vessels diminish, succulent tissues contract, and the normal condition returns.

This would be the picture in simple acute synovitis in the adult, and may take place in the child, but more likely in the latter the process progresses and intensifies. The leucocytes and cells collect in such numbers that the synovia becomes milky, almost pure pus; the inflammation is still limited to the membrane and subsynovial tissue,—is still, so to speak, superficial,—and is designated *purulent (catarrhal)*. But if the process advances, the cartilages are involved, thicken, become cloudy and yellow, and later are eroded, laying bare the bone, the surface of the epiphysis is destroyed, and extensive ulceration and joint-destruction follow,—*suppurative synovitis*.

While in the child these destructive changes follow one another rapidly, yet they may, though rarely, be arrested at any one point, and if this arrest occur in an early stage restitution may be complete, or the change may be into the hyperplastic form.

It may be observed that a purulent synovitis following wound of a joint admits of a better prognosis in youth than in adults.

The specific fevers, especially typhoid, and rarely small-pox, are occasionally followed by arthritis, generally monarticular synovitis, or the cartilages and ligaments may be involved, producing much stiffness. Following typhoid the hip-joint is the one most generally attacked. After scarlet fever many joints may be affected; the same result has been observed to follow mumps, dysentery, and measles. If suppuration occurs it is confined to one joint. Rheumatic synovitis may also be included under this general division. In all these cases the process rapidly retrogrades under proper treatment, or results in a simple hyperplastic thickening of the membrane, with shrinking and fixation of the joint.

How it happens that the joints are affected in these specific fevers is a question yet *sub judice*; it is, however, likely that during the course of the primary disease some centre of infection is established from which septic material is absorbed.

When a synovitis is lighted up by the breaking through into the joint of pus from a bone-abscess or a neighboring periostitis, the advancing destructive process is very rapid, a panarthritis is produced which the most heroic therapeutic measures will scarcely arrest, and, in short, it may become a question not merely of saving the joint, but even of saving life.

The synovitis which in its results is hyperplastic in character may be simply benignant, or a destructive fungus; the former is rare in children, though, as already hinted, it may follow the infectious diseases or rheumatism as a polyarticular trouble; the latter as a fungous or strumous synovitis is an essentially different process. Here is formed a granulation-tissue, soft, spongy, rich in vessels and cells, interspersed with small yellowish papules which contain giant cells rich in nuclei, giving to the papules the histological character of miliary tubercle. The membrane becomes swollen, opalescent, and succulent, is loaded with exudation-products, and its surface assumes the appearance of granulation-tissue. The membrane continues to thicken, becomes soft and friable, and contains masses of caseous material. Later

suppuration occurs. If not arrested, the inflammatory process extends to the joint-cartilages, ligaments, and bones, and a veritable panarthrititis results.

If these cells are miliary tubercles, the interesting question arises, whence came they? Could it be from thickened, cheesy points of inflammation in the immediate neighborhood of the joint,—for example, in the epiphysial ends of the bones? This fungous inflammation does not partake of the character of a simple hyperplasia, but rather of that of a neoplasia, the tendency of which is to spread out on all the histologically different tissues of the joint and in the neighboring connective tissue; so that in place of the normal outlines of the joint there is to be found a thickened firm mass,—“white swelling.”

It is this peculiarity that makes the affection so intractable, so dreaded by the surgeon, for he knows not where he may arrest it.

It may be difficult, in any given case, to determine whether the fungous (tuberculous?) process originates in the synovial membrane, in the inter-capsular ligament,—teres or crucial respectively,—in the interarticular cartilage, or in a single cheesy point in the epiphysis, whose rupture infects the cavity of the joint. But observations of many cases in different stages of development throw the weight of opinion decidedly in favor of the latter as being the more common.

When commencing in the synovial membrane, the fungoid disease appears like a circumscribed tumor, which in the early stage interferes but little with the functions of the joint; it is only later that a general implication of the articulation occurs.

In the primary bony forms the process appears to begin in the neighborhood of the cheesy osteitic point, and extends gradually towards the joint-end, rupturing near the place of duplicature of the capsule or through the cartilage into the cavity of the joint. In the one case the process can remain localized for a relatively long time, can spread upon the perisynovial tissue, can ulcerate, burrow, and form fistule without involving the joint *in toto*; in the other case the course is acute, the total implication of the joint being well marked by the clinical features.

The fungous mass ulcerates and breaks up, pus forms, the cartilage softens and disappears, the ligaments soften, the bones become carious, “surgical fever” is present, and the case is critical as regards not only the integrity of the joint, but even the life of the patient. Fungous synovitis does not necessarily lead such a galloping, destructive course. It may under wise treatment, in a case of not too thoroughly depraved constitution, be arrested in any period of its course,—in the earlier stages with motion, in the later with ankylosis.

#### SYMPTOMATOLOGY.

Simple synovitis declares itself by pain, moderate at first, but increasing in severity, especially at night; by swelling of the joint within the boundaries of the capsule, indicated by fluctuation; by heat of surface in the

superficial joints; by redness of skin in severe cases; by atrophy of contiguous muscles; by position of the joint, usually flexion,—“position of greatest ease;” and by limited or arrested motion. If the attack is quite acute these signs may be marked; otherwise some of them may be obscure and come on slowly. The child complains of a feeling of weariness and uncertain, nagging pains, which may be relieved for some time by quiet and position, or be aggravated by much motion. In the morning the joint will be stiff, in the evening more movable, but painful, hotter, and more sensitive to pressure. This condition drags along, the symptoms slowly increasing in severity until possibly sharply circumscribed points of pain lead to the suspicion of bone-involvement.

The forms of synovitis following the infectious diseases, in the likeness of acute joint rheumatisms, are indicated in the joints affected by markedly increased surface-heat, sensitiveness from the beginning, swelling, the skin red and shining, and the joint held motionless. The attack may be poly-articular, one joint after another becoming successively involved, skipping so rapidly that great swelling does not occur in any, though the pain is marked.

Rauchfuss has given us the symptoms of a sero-purulent synovitis that attacks infants, in which the exudation develops rapidly and may in a short time take on a purely purulent character. In the beginning the child is feverish and restless; examination of the nude body discloses immobility of one or more limbs and great sensitiveness to the touch. After twenty-four hours the skin over the affected joint, if superficial, like the knee or ankle, becomes red. If a deep joint, like the hip or shoulder, is the one involved, several days may supervene before the exudation can positively be demonstrated. The affected joints during this period assume certain fixed positions: the hip and knee flex, while the arm is drawn to the side of the chest. With care, fluctuation can be recognized in and about these joints. If in this stage the joint is emptied by puncture or tapping, motion becomes freer, and the pain and fever lessen, but the fluid reaccumulates rapidly, so that on the same day there may again be found the redness and tension. When the emptying is repeated daily with all due precautions, the exudation loses gradually its blennorrhagic character, appears more serous and more fluid, pus-cells undergo fatty degeneration and break up, and after many days the secretion disappears and the function of the articulation is restored. In very young children one or two timely openings bring the process to an end; in protracted cases the cure may take a longer time, or the process may come to a bad ending through ulceration of the cartilage, destruction of the epiphysis, rapidly-fatal meningitis, etc. Superficial cartilage once destroyed may be entirely restored through the active growth of these parts in infancy, and putrid discharge of the secretion is usually well borne by children.

There is a synovitis secondary to neighboring bone-disease, caused either by contiguity of the inflammation or by the products of the bone-disease breaking into the joint-cavity and as a local irritant inducing the disturb-



ance. In acute osteo-myelitis the passage of pus into the joint occurs in the later stages, and is marked by an exacerbation of the symptoms,—increased pain and swelling, and elevation of temperature. In chronic osteo-myelitis the neighboring joint is enlarged, the membrane is thickened, and there are acute exacerbations of pain and swelling as from time to time pus finds its way into the joint. A seasonable tapping assists in the diagnosis and becomes an admirable therapeutic measure. In circumscribed osteitis of the joint-ends of the bones the articulation is enlarged, with serous effusion, but is not especially tender or immovable, but when the pus has made its way into the cavity acute joint-irritation, with fixedness and aggravation of all symptoms, is produced.

Acute suppurative synovitis is known by the rapidity and severity of the symptoms, especially if septic matter has been carried into the joint by wound of the capsule. A traumatism may induce a serous synovitis, which under appropriate therapeutic measures subsides, or under adverse circumstances may advance to suppuration, which would at once be indicated by a high temperature. The more severe outcome is less likely to happen in children than in adults.

The hyperplastic proliferating synovitis, at times following the infectious diseases, at other times rheumatic in character, attacks several joints with the signs of acute exudative arthritis. The inflammatory conditions only partly disappear, leaving a thickening of the joint, doughy in character, admitting only of limited painful motion. The joints become flexed and retain abnormal positions, even after the inflammatory action has passed; the capsule shrinks, and the soft parts contract and adapt themselves accordingly.

The symptoms of strumous or fungous synovitis develop slowly, indicative of a subacute process. Usually some advance has been made in the affection before the physician's attention is called to the case. Impairment of motion, stiffness, lameness or limping, occasional pain, increased by passive movement, tenderness on firm pressure, uneasy sleep, with an occasional night cry, are present in the early weeks or, it may be, months. Without early recognition of the gravity of the affection and correct treatment, the case passes on into one of those chronic joint-diseases with which all are so familiar in children, happily less frequent now than formerly, because earlier recognized, better understood, and more rationally treated. In the examination, if the corresponding limb or joint is compared with the affected one, the muscles of the latter will be found by circumferential measurement atrophied, an important diagnostic point, always present to a greater or less degree. The wasting is greater and more rapid when the disease is grave, slight and slowly developed when still mild. This atrophy of the neighboring muscles causes the joint to appear relatively larger, the contours are changed, depressions are rounded out, and a boggy sensation is imparted to the touch. The swelling is less evident in the deeper-lying joints, as the hip and shoulder, but in the superficial articulations will be

demonstrated without difficulty. In advanced disease much of the swelling will be due to infiltration of the surrounding parts and probably to abscess. The amount of pain is variable: it may be so slight as to mislead, and again may be a constant and distressing symptom from the beginning; it is usually increased by exercise of the part, and frequently causes the patient to cry out at night. Limitation of motion is present even from the inception of the disease, and becomes more marked as it advances. Flexion may be possible, but complete extension is rare, and rotation is greatly impeded. The former practice of giving an anæsthetic in determining the presence of joint-disease is to be deprecated. It was once thought that unless under its employment grating of the joint-surfaces could be detected no disease was present; we now know better, and, further, that it robs us of one of the most sensitive indications of articular trouble,—namely, reflex muscular contraction. By obtaining by gentle means the confidence of the patient, by manipulating first his sound limb, thus drawing his attention from the affected one, and by the use of tact in managing the frightened or angry child, resort to chloroform will never be found necessary. Definite positions are assumed by the different joints, usually that of flexion; naturally, the patient holds the limb in the position of greatest comfort; and certain groups of muscles are doubtless excited to reflex contraction more strongly than others. Slightly-increased heat is detected in the superficial joints. As the disease advances, enlargement and softening will indicate the presence of pus. Throughout the disease a diurnal (evening) rise of temperature will be noted, more marked in the later stages. The appetite fails. Pallor of skin and general wasting of body, with disturbed sleep and irritable temper, are present. If an abscess opens, flaky pus escapes. Night-sweats and diarrhœa may supervene. Amyloid degeneration may attack the glands, or tubercular meningitis may complicate the case.

#### ETIOLOGY.

The cause of simple or sero-synovitis may be local injury, a blow from without, a wrench within, fatigue from long exertion, or exposure to cold and wet: often the cause cannot be assigned. If early recognized and properly treated, the inflammation will subside; otherwise it will run on into a chronic state and possibly assume a hyperplastic form. In girls at the catamenial age it has been observed that with a cessation of the menses a serous synovitis ensued.

Joint-affections are sequelæ or concomitants of the exanthemata,—scarlet fever, typhoid fever, small-pox, etc.,—one or more articulations being affected; the same after measles, dysentery, and mumps. Pus very rarely forms. As already suggested, some centre of infection in connection with the general disease furnishes septic matter for absorption, which lights up local inflammation in the joint. Some hold to the theory that the cause is a specific poison circulating in the blood.

It is difficult to find sufficient cause for the sero-purulent synovitis that

occasionally attacks young infants. An explanation has been sought in the bowel-troubles incident to that age. It is monarticular in character, and attacks by preference the shoulder, the hip, or the knee. The cause is more readily understood when a local inflammation in the form of an osteitis of the neighboring epiphysis is lighted up, due to blood-poisoning, or to injury during or soon after birth, or to an osteo-myelitis of the bone-ends in older children, strumous or syphilitic in character or due to local injury or to exposure to cold and wet. Here from contiguity of the inflammation the joint becomes involved, and later when pus breaks into the cavity severe and marked symptoms suddenly manifest themselves.

We seek for the cause of fungoid synovitis in a constitutional dyscrasia with some local injury to determine its expression in the individual joint. A traumatism—blow, fall, wrench—can usually be traced. It is, however, the constitutional peculiarity that gives the characteristic history and expression to the disease. For lack of a better term, this systemic condition is styled strumous or serofulous: it consists in a defective state of the general health, with a tendency to chronic inflammation of certain tissues, leading to fungous growth, suppuration, and caseation. This state of the health may be hereditary or acquired,—tuberculous as an example of the former; impaired health from precursory acute disease, or from poor food, vitiated air, dark, damp dwellings, as examples of the latter. That serofulosis and tuberculosis are one and the same cannot yet be admitted; that they are allied must be acknowledged; possibly the former is a stage or degree of the latter; certainly they have much in common, so that we are not surprised to find the tubercle-bacillus in the hyperplastic tissue of advanced fungous synovitis. While, as a rule, a constitutional cause may be found for the local affection, yet in children apparently free from any taint or ill health the joint-trouble may develop, and, as previously hinted, a neglected simple synovitis may advance and change into a chronic fungous condition, with suppuration and destruction of the joint. The joints of the inferior extremity are more frequently found diseased than those of the upper. How else can this be accounted for than by the fact that they are more subject to trauma from concussion in running, jumping, and falling? If general or constitutional cause had all to do in their production, this difference in frequency between the upper and the lower limbs would not exist. We are thus forced to believe in a constitutional impairment as a predisposing cause, and in a local injury as an exciting cause. In the matter of predisposition, it must be admitted that breathing vitiated air (it may be from house-furnaces), living too much in-doors, eating too rich food, with late hours and nervous excitement,—all these, even among the well-to-do classes, would undermine the health of the young. It can be readily understood why in the earlier years of life, while active tissue-change is going on in the joints,—in the cartilaginous epiphysial bone-ends,—transition from the fetal to the adult forms,—the articulations should be so vulnerable to local injury.

## THERAPEUTICS.

The sheet-anchor in the treatment of all joint-diseases in children is rest to the inflamed articulation. When the inflammation is arrested, motion may be permitted, but not until then. Rest in the beginning, in the middle, and at the ending of the diseased process should be the therapeutic maxim. Oftentimes the problem concerning us most is how best, by what appliances, to immobilize the joint. The ingenuity of surgeons has been taxed to supply an apparatus that would do this and yet not interfere too materially with what was necessary in the way of obtaining fresh air, sunlight, exercise, to the improving of the general condition. At the very outset it is necessary to keep in mind the importance of rest and position to an inflamed joint; doing so will materially simplify our therapeutics.

In acute simple synovitis the limb has naturally taken the position of greatest ease, but this is not always the position of greatest usefulness should, unhappily, the joint become stiff. To extend or otherwise place the joint in the best possible position should very early be the aim of the surgeon,—by gentle measures if possible, under anaesthesia if necessary. Ordinarily the rest and relaxation afforded by an efficiently supporting splint cause the muscular rigidity to subside, so that the limb can after a few days be placed in an improved position. Leather, metal, felt, gypsum, or pasteboard splints may be used, and additionally in the upper extremity a sling: in the lower limb the weight of the body should be taken off the joint by adopting the horizontal position. Elevation of the limb lessens the amount of blood-tension in the joint, and evaporating lotions or cold-water irrigations will help to reduce the inflammation, if high. Equable pressure, attained by enveloping the joint in prepared wool surrounded by rubber bandage, will hasten absorption of the secretion; if, however, the latter persists, aspiration of the joint under antiseptic precautions will afford marked relief. Later the hardness and stiffness may be removed by massage and douching. Iodine, in the form of tincture to which a little glycerin has been added, or the compound ointment, may be applied externally. Care must be exercised in the employment of blisters in the young.

In the way of general treatment, if fever exists, half-drop doses of the tincture of aconite may be administered every hour or two until the pulse is reduced, and morphine injections or Dover's powder by the mouth until the pain is relieved. Milk broth and farinaceous diet should be given for a time. So long as pain or heat exists in the joint, the immobilization should be continued. Again reference is made to the importance of not moving the joint until all inflammation has subsided.

Suppurative synovitis and arthritis require prompt remedial measures: thorough immobilization and support to the joint and limb by a splint so arranged that access to the joint can be had; in the acute stage cold to the articulation, and aconite internally. Marked fluctuation in the joint would suggest aspiration, which is often attended with great relief of symptoms.

If pus is detected, free opening of the joint under antiseptic precautions, with efficient drainage and antiseptic dressings, will afford relief and give a favorable turn to events. If pus appears in another part of the joint, it, too, must be evacuated. It has been suggested that instead of employing the knife, objectionable on account of hemorrhage, the trocar be used, and that if matter reaccumulates the second tapping should be done in the same spot as the first. If the opening of the joint has been too long delayed, so that the case is going on from bad to worse, if the joint becomes disorganized, and profuse suppuration continues, with burrowing of matter, and the general health is giving way, with loss of appetite, and high fever, amputation must be considered, and promptly performed if deemed advisable.

The acute purulent synovitis of infants usually demands prompt emptying of the joint with the aspirator or the trocar, to be repeated as required.

Synovitis secondary to neighboring osteo-myelitis or periostitis requires for effectual treatment removal of the cause, in addition to the special treatment of the joint-complications, conducted on general principles, with punctures and immobilization. So, too, in the joint-troubles following pyæmia and the exanthemata, rest and support, and, when matter is confined to the joint, tappings; but if pus has escaped from bursting of the capsule into the surrounding tissues, free opening, with drainage, will be necessary.

Of all the forms of synovitis, that which interests us most as regards therapeutic management is the fungoid or strumous, because it is so common, so chronic, leads to such untoward results as to permanent maiming and as to life, and because differences of opinion yet exist among surgeons as to the best means to be employed for its relief. The term fungoid would indicate the presence of a material which should be modified, destroyed, or removed that a favorable issue be attained in the treatment: so, very naturally, injection of antiseptic agents into the joint was thought of and employed. Most commonly carbolic acid has been used, from a two-per-cent. solution up to a thirty-three per cent. and a fifty per cent. concentrated, eighty centigrammes to each injection of the former, repeated as high as fifty-two times, and twelve to twenty-five centigrammes of the latter. Iodine also has been employed for the same purpose. Favorable reports on the use of both of these agents have been given by some experimenters. On the other hand, such poor or negative results have been obtained by others that the method is as yet far from being universally accepted. For a time good results would seem to follow, yet they were not permanent. Further observations in this direction are necessary before we can advise resort to antiseptic injections as a therapeutic measure.

Late in the disease, when all hope is past that mild measures will arrest the progress of the destructive changes, resort may well be had to the removal of the fungus, now doubtless tuberculous, by heroic measures, such as opening the joint, scraping with the spoon, and clipping with

the scissors, thus thoroughly removing all the diseased tissue, under antiseptic irrigation and dressings. But one hesitates to resort to such extreme measures until simpler means have been tried to alleviate the disease. Such simpler measures should be, as already suggested, immobilization of the joint, and, in addition, in some instances, counter-irritation and compression; for the former iodine, tincture or ointment, for the latter mercurial plaster in strips, or preferably the elastic bandage. But if, as previously suggested, there exists constitutional involvement in this disease, it, too, merits attention, and correction as far as may be, by the use of good food, fresh air, bathing, sunlight, and exercise, and for medicine the hypophosphites, with malt and cod-liver oil if borne.

In the joints of the upper extremity this indication of local rest can readily be fulfilled, the splint being best made of leather or felt, as being light, moulded over the part or preferably over a gypsum cast. By immobilization is not meant intermittent fixation: it must be thorough and constant. At no time after the inception of the treatment should the joint be moved, otherwise granulations may be torn and slight hemorrhages result.

In the inferior extremity the articulation may be prevented from bending, but additionally it will be necessary to prevent the concussion incident to weight-bearing. The ankle and knee can be efficiently fixed by firm leather splints, lacing at the side or in front, and the weight of the body taken from the limb by crutches, with a patten on the opposite boot; or the ischiatic crutch-splint of Mr. Thomas will meet both indications, though uncomfortably worn by some. In the hip-joint a strong pathological factor to be overcome is the contraction of the muscles, giving an abnormal posture to the limb and aggravating the joint-pressure. Extension by stirrup, weight, and pulley in horizontal position will readily overcome these symptoms, give the limb its most desirable position, ease the pain, and immobilize the joint if the trunk is kept supine. If one plans to carry a case of hip-joint disease to a successful issue by this method, not only the extremity but also the body should be tied down; for it is immaterial whether the limb is flexed on the body or the trunk is bent on the limb,—in either case motion in the joint results. This plan is adopted by Mr. Marsh, his patients being constantly confined to their beds. In the early stages of the affection this method of extension and counter-extension is correct so far as the beneficial local effect is concerned, but the protracted confinement as witnessed at the Alexandria hospital is objectionable, as tending to undermine the general health. This objection is largely overcome by confining the patient to a splint which, while allowing extension and counter-extension, enforces absolute immobility of the joint under all circumstances, and yet permits the removal of the patient from place to place, into the open air and sunlight, and even the riding in a child's carriage.

This splint consists of an iron frame covered with canvas, except a two- or three-inch space in the centre for convenience of defecation, two detach-

able steel pieces, one upright at the foot, for extension from a stirrup-strap, and one a curved arm at about the middle stretching over and beyond the centre, for attachment of the counter-extending perineal straps. Webbing over the chest fixed to the sides prevents the patient from sitting up. Occasionally with a very restless child a third steel piece arches over the lower third of the thigh, to fix the knee. One inferior and both superior extremities are free, also the head and neck; otherwise there is immobilization of the trunk, with extension and fixation of the hip-joint.

On this "stretcher-splint" the nurse can carry the child from place to place and attend to all his wants. He improves in flesh, the pain rapidly disappears, and a happy countenance takes the place of the previous anxious look. No bed-sores form, though children have thus been confined from five to eight months continuously, and with the best results. Three to four months' use of the splint will usually suffice if the case is taken early and the constitutional cachexia is not too strongly marked. Following this a Thomas's splint should be used until the cure is complete. Complicating abscesses are to be opened promptly by incision, all antiseptic precautions being observed during the operation and in the after-treatment.

A rare cause of subacute inflammation of the synovial membrane is the presence of blood in the joint, found occasionally in cases of hæmophilia. To this I called attention as early as 1868, the joint involved in the case being the hip. It may attack any joint, the knee preferably. The symptoms are soreness of the joint, pain on motion, sudden swelling, possibly fluctuation, and slight heat. Immobilization and equable pressure cause absorption of the contained fluid and subsidence of the attack. The temptation would be great to tap the joint; but if there is any suspicion of the cause of the trouble, or if attention is called to the fact that the patient is a bleeder, all wounds should of course be avoided.

# DISEASES OF THE MAJOR ARTICULATIONS.

BY CHARLES T. POORE, M.D.

---

DISEASE of the joints is one of the most common surgical complaints of childhood: it is met with among all classes and in all conditions of life; no period is exempt from it. From the moment of birth (for a child may even be born with a diseased joint) to adult life articular inflammations are common. While these often yield readily to treatment when taken in time, they are, on the other hand, most rebellious and disastrous when neglected or treated improperly. The subject therefore demands careful consideration.

The structure of the articular ends of the long bones in infancy and childhood differs from that in adults in certain important respects; the younger the child the more marked is the difference. In early life the epiphyses are to a greater extent within the synovial cavity than in the adult; they are composed mainly of cartilage, with points of ossification in their centre; "they increase in all directions by interstitial growth, and the ossification advances from within outward;"<sup>1</sup> and they are separated from the diaphysis by the epiphysial cartilage or disk. Both the epiphyses and the diaphysial ends of the long bones are seats of exceedingly active formative processes. Not only do the epiphyses themselves increase in all directions, but the long bones grow in length by addition at their articular end. The parts in these situations are very vascular, and, as in all tissue where active growth is going on, healthy nutrition is easily supplanted by pathological processes. Recently-formed tissue has feeble resisting power, and therefore is less able to withstand morbid action. Another peculiarity that marks the difference between the infantile and the adult bone is that the nutrition of the epiphyses in childhood is not dependent on that of the diaphyses; this explains the fact that the diaphyses may be completely destroyed while the epiphyses continue to grow, and, on the other hand, the latter may be involved in disease while the former escape. These considerations render the study of joint-affections in childhood different from that of the same affections in adults. The nearer a child approaches puberty, the more does the course of articular inflammation resemble that in adults.

Joints vary in their liability to become affected with chronic disease.

---

<sup>1</sup> Macnamara, Diseases of the Bones and Joints.



The hip-joint is by far the most frequently involved; next the knee; then the ankle, then the shoulder, and last the elbow, of the larger articulations. The knee is most frequently attacked by acute affections, due probably to its size and its greater exposure to cold and injury.

Acute joint-affection is not so commonly met with as chronic, the latter being the surgical disease of infancy and childhood.

Diseases of the joints may be further divided into tubercular and non-tubercular affections; also into diseases beginning in the joint itself (synovial affections) and those commencing in the bone, the articulation being secondarily affected.

#### TUBERCULAR AFFECTION OF THE ARTICULAR ENDS OF BONES.

Tubercular affection of bones is a chronic disease; it is more frequently met with than any other, so that some surgeons almost deny the existence of a non-tubercular affection in children. Before considering the pathology of tubercular disease of joints, it will be necessary to define just what is meant by the expression "tubercular."

Formerly these chronic joint-troubles were called strumous or scrofulous. The expressions "struma" and "scrofula" were then applied to certain chronic inflammatory processes affecting the lymphatic glands, the skin, mucous membrane, testes, bones, and joints, and occurring almost exclusively in children and young adults, characterized by a tendency to spread by local infection, and prone to caseous degeneration.<sup>1</sup> A scrofulous individual, so called, was one liable to the occurrence of chronic inflammation of the tissues mentioned above, from the slightest exciting cause, the process being marked by rapid cell-proliferation, with defective power of organization. The term "tubercular" was limited to the gray granulations and caseous nodules affecting the lungs, viscera, and serous membranes. The scrofulous diathesis, it was admitted, was often inherited from tuberculous parents, and was accompanied by a tendency in the individual so affected to develop gray tubercles in the lungs or serous membranes; but a strumous person was not necessarily considered tuberculous in the then-accepted definition of the term. The strumous diathesis was looked upon as related to, but not identical with, the tubercular. Such were the commonly-accepted views held regarding the relation between struma and scrofula, and tuberculosis, although the line between them was getting exceedingly narrow; yet not until the last few years, when Koch proved that the two processes were pathologically identical, have they been obliterated. They are both manifestations of a chronic bacteritic disease, which is produced by a tangible organic contagion, and that contagion is a specific bacillus, and tubercle is an inflammatory product resulting from the presence of the bacillus in the tissue in which it has become lodged.<sup>2</sup> Inoculation of the so-called

<sup>1</sup> Treves, Manual of Surgery, vol. i. p. 216.

<sup>2</sup> Marsh, Diseases of the Joints, p. 97.

strumous material produces tubercle in the old acceptation of that term, and tubercular matter produces the so-called strumous deposit in glands; and, further, the tubercle-bacillus is found in both growths. All persons are not equally susceptible to tubercular infection: it therefore still remains to define that condition or state of the tissues which predisposes to, or affords a proper soil for, the lodgement and development of the bacillus. This is still called the strumous diathesis, meaning thereby a certain vulnerability or proclivity of the tissues to the development of tubercle. A better expression would be "tuberculous."

It is a well-established fact that a child seldom inherits the bacillus; it simply is born with some defect in its constitution that predisposes it to the lodgement and development of tubercle in certain tissues.

This diathesis may be acquired in the course of any debilitating disease, from impure air, bad food, or unhealthy surroundings. The exanthematous diseases may and often do implant upon the tissues of a previously perfectly healthy child a soil in which the bacillus can gain lodgement and thrive.

The bacillus gains access to the body either by the respiratory passage, by the intestinal tract, or through a wound. Whether it will obtain a lodgement and develop depends upon the resisting power of the tissue: if the child is healthy the bacillus will be arrested in its development and kept at bay until it is finally eliminated or destroyed; if, on the other hand, his vital powers have not sufficient resisting force, it gains lodgement and grows under certain unknown conditions.

It is generally considered that joints are infected from some other foci in the body. Baker<sup>1</sup> states, "It is almost certain that in tubercular disease of joints we are dealing with a secondary infection in the vast majority of cases; that the organism introduced into the system elsewhere and present in the blood has found in its wanderings a home peculiarly fitted for its growth in the tissues of the joint. There are only two tissues about a joint in which the bacillus can find lodgement,—the synovial membrane and the cancellous tissue of the bones."

Some months ago I operated upon a robust, well-nourished child five years of age for tubercular disease of the wrist-joint: there was nothing of interest about the operation. The child died in a few weeks from diphtheria; and on post-mortem examination tubercles were found in the lungs and the bronchial glands were filled with caseous matters of much older date, some of them showing calcareous degeneration. No tubercles were found about the seat of operation. The bones of the wrist were in all probability infected from the glands.

There are two circumstances which contribute to the development of tubercle in the articular ends of bones in children: first, the active nutritive process going on at the articular ends of growing bones, which means greater flow of blood to the parts; and, secondly, the low vitality of the

---

<sup>1</sup> British Medical Journal, 1888, vol. i. p. 1259.

new tissue; for it is a well-known fact that the cells of recently-formed tissue have weak resisting power,—in other words, their vitality is low. In a child who has either inherited or acquired a “tubercular diathesis,” whose tissues have therefore less resisting power than a healthy child’s, the bacillus circulating in the blood from an old deposit would gain lodgement in those parts of the body less able to resist it and those to which the supply of blood was less free. There is no tissue in the body in which these conditions are more perfectly filled than in the articular ends of growing bones, and practically we find them the most common seat of tubercular disease. A perfectly healthy child, one in whom there is no tubercular predisposition either inherited or acquired, will not develop strumous disease of a joint, any more than a perfectly healthy adult under similar circumstances will develop tuberculosis of the lungs; but if the adult be exposed to vitiated air, privations, or bad hygiene, he may and often does engraft upon his constitution a condition congenial for the development of tubercle; and the same holds true in regard to joint-disease in childhood. Baker states (*loc. cit.*), that “there are several kinds of predispositions to tubercular disease of joints. In the first place, a peculiar debility may be inherited from a phthisical or otherwise unhealthy parent, rendering the tissues of the child generally less capable of repelling the attack of the parasite than had it come from a robust stock; next there is the general predisposition of early age, the tissues of the young having less resisting force than those of the mature. Thereby certain locations of the body appear to be particularly open to the attacks of the organism, probably owing to the hurried physiological changes involved in rapid growth in them,—changes which are associated with the presence of abundance of almost embryonic tissues and great vascularity.”

There may be and often is another contributing cause of bone-tuberculosis called an “exciting” cause, and that is injury. Traumatism renders the tissues more open to the deposit of the bacillus present in the blood, in several ways. It may cause more or less inflammation with exudation; such exudation is of lower vitality than the normal structure, and therefore of less resisting power, and thus forms a favorable nidus for the lodgement and growth of the bacillus; and the increased flow of blood to the part brings a greater supply of the parasite. Injury may cause a loss or lowering of the vitality or tone of the tissues, favoring passive congestion; this slowing of the current offers a better chance for the deposit of the contagium. Contusions of the bones may cause more or less extravasation of blood, and with the blood the bacillus also escapes, and in this situation meets with the most favorable conditions for further growth. Baker (*loc. cit.*) considers the last-mentioned effect of injury the most potent factor in determining the point at which tubercular disease makes its appearance in those who, by inheritance or physical conditions, have acquired a soil congenial for the development of the parasite. Tubercles, having become deposited in the cancellous tissues at the end of a bone, act as an irritant, and, as a

rule, inflammatory processes take place about it, so that fibrin is thrown out, forming a capsule around it. The contents of the capsule after attaining a certain stage of development undergo retrogressive changes, owing to the lack of blood-supply. These are of a caseous, fatty, and necrotic character. Sometimes this limiting tissue consists of sclerosed bone; after a time, in certain cases, the contents of the shell undergo liquefaction, which may finally break through its limiting membrane and further infect the bone, forming new and larger deposits filled with bony detritus and charged tubercular matter. If these bone-abscesses are of any size, they often contain sequestra.

Savory<sup>1</sup> has drawn attention "to the analogy that exists between the progress and effects of tubercle in the lungs and in the bone. The cancellous texture of bone, which is the seat of tubercle, resembles broadly in physical characters the parenchyma of the lungs. . . . In both cases the spongy texture appears to be filled up and rendered solid by the infiltration of caseous deposit; then, too, the resemblance further appears in the halo of inflammation or increased vascularity of varying width which so often surrounds the mass. Still further is the likeness shown in the mode in which tubercle degenerates. The included tissue is broken down and destroyed, until a cavity is left in the cancellous bone corresponding remarkably to a vomica in lung. Further, the likeness is extended by the relation of cancellous bone to the neighboring joint and the relation of the lung-substance to the plenra."

König divides bone-tuberculosis into three classes: (1) the dry form, where there is a tendency in the tubercular mass to be transformed into cicatricial tissue and thus prevent the distribution of the bacillus; (2) those cases in which the vegetation degenerates into a soft gummous detritus, which shows a disposition to infect the tissues in its immediate vicinity, and thus tends to the spread of the disease; (3) an infiltrating variety, in which the bone becomes infiltrated with tubercle, showing no limiting barrier; the cancellous tissue of the bone becomes rapidly involved in one mass of disease. In the latter form the joint soon becomes infected, and the patient dies early from general tuberculosis. As long as the walls of these tubercular foci remain unbroken, or do not become infected, extension of the disease does not take place. The tendency of these deposits to undergo changes is great: it is always either towards cicatrization or towards liquefaction and caseation. The size of these caseous deposits varies: they may occupy a considerable space of the end of the bone, or may be confined to a small area.

Tubercle in bone in its early stage is invisible to the naked eye; later, however, after it has acted as an irritant and increased in size, a halo of inflammation or vascular redness appears around the deposit; sometimes a caseous mass of considerable size is surrounded by this vascular zone, which

---

<sup>1</sup> Lancet, 1882, vol. ii. p. 738.

gradually shades off into the healthy bone. In some examples, if these deposits are not of recent formation, the mass will be surrounded with a shell of sclerosed bone, due to the osteitis that has taken place around it. When first visible, a solitary tubercle appears as a semi-transparent circular spot, with an opaque centre, quite bloodless, and often with a somewhat irregular border, the surrounding bone-medulla being of a deep-red color. The junction of several isolated tubercles forms a mass of granulation having a grayish, granular, semi-transparent aspect, or, if the disease is of long standing, the patch presents a decidedly caseous appearance. At the periphery of such masses the medulla is observed to contain no fat-cells; its blood-vessels are dilated, and no longer have connective tissue around them.<sup>1</sup> When tubercular granulations develop in bone, they produce obliteration of the existing blood-vessels, and this leads to caseous degeneration. These slowly-progressing caseous patches are often preceded by a chronic osteitis, and terminate in suppuration, with softening and destruction of the proper bone tissues, and finally in perforation of the bone. In other examples—those in which the bone has become infiltrated with tubercle—there is no limiting inflammatory exudation: the whole bony tissue is softened and filled with the products of inflammation,—namely, pus, broken-down osseous tissue, and tubercular matter; the bone is spongy and dark-colored and can easily be crushed under the fingers. If the tubercle takes on a cicatrizing process, the parasite is in time destroyed, and the remains of the deposit are represented by a mass of fibrous tissue. In excising joints we often meet with irregular-shaped spaces in the bone filled with firm connective tissue: these are the remains of tubercular deposits which have undergone the cicatrizing process. In cases where the deposit, although at first confined within narrow limits, has liquefied and either broken through or infected the limiting zone of inflammatory exudation, the bone may become infected, and general tubercular infiltration of the cancellous tissue may follow, as in the first-mentioned variety. Often the deposit breaks down and forms a cavity in the bone of greater or less size; this may either become a caseous mass or discharge in the direction of the least resistance, and this, too, is often into the joint-cavity. In its slow progress towards the joint the bone is destroyed and the cavity becomes enlarged, containing broken-down tubercular matter, bony detritus, and frequently sequestra of varying size; finally the articular lamella of bone is reached and the joint involved. Sometimes these tubercular abscesses have a different history; they make their way to the surface of the bone entirely outside of the joint-cavity, perforate the compact tissue, form collections of matter in the surrounding soft parts, and finally open through the skin; we then have a sinus leading to a cavity in the articular end of the bone, often containing a sequestrum. Even when they follow this course the joint, in many cases, does not escape, for the disease may also travel

---

<sup>1</sup> Cornil and Ranvier.

towards the articulation and involve it. The ultimate result, so far as the joint is concerned, depends upon the situation of these tubercular deposits and the course pursued by them, whether they take on a cicatrizing process, break down and discharge into the joint, or infiltrate the cancellous tissue in the end of the bones. If the tubercular deposit takes on a cicatrizing process and is replaced by connective tissue, the parts around return to their normal condition and give no further trouble. In cases where the tubercle breaks down, liquefies, and caseates, and becomes surrounded with a shell of sclerosed bone, it may cease to act as an irritant to the parts and may remain an indefinite time without giving any trouble, all pain having ceased and the child going about without any discomfort; or there may be pain about the bone at times in damp weather or after exercise, sometimes tenderness over the parts on pressure, often aching of the limb, passing off and reappearing again. I have seen quite a number of cases giving such a history, and have always found, when any operation has been called for, that there were caseous masses of considerable size in the end of the bone, the joint-trouble having ceased, or showing only the remains of previous disease. Finally, in those cases in which an abscess is formed in the bone it may progress until it opens into the articulation.

The joint may be affected with disease in two ways: first, by contiguity of tissue; secondly, by the opening of a tubercular abscess into the joint-cavity. It should be noted, however, that the articulation is frequently first affected in the former way, while later it is infected directly from the abscess.

As these bone-abscesses increase in size, more and more of the cancellous tissue becomes involved, and the area of the inflammatory halo extends until it approaches that portion of the bone to which the articular cartilage is attached and from which it gains its nutrition; finally it reaches a point just within this tissue. The effect is first to cause congestion, and later to diminish and then cut off the vascular supply. The articular cartilage first loses its bluish color and becomes of a yellowish hue; later it is raised like a blister from the bone over an extent of surface corresponding to the extent of the disease in the bone behind it; finally a perforation takes place, and the contents of the abscess gain access to the articulation. These holes in the cartilage have a very characteristic appearance: they have clean-cut edges, as though they were cut out with a punch; their contour is often irregular; the surrounding cartilage retains its normal white color. Often there are a number of places presenting this characteristic loss of substance, depending upon the amount and extent of the disease in the bone; at times the whole bone under the cartilage will be affected with osteitis, and will present an irregular granular appearance and be covered with exudation. In such cases the whole articular cartilage may be detached in a mass, like a cap, from its bony attachment. In other cases only islets of apparently normal cartilage will be seen, the rest of this tissue having been destroyed. In all these cases the joint has long been disorganized, its capsule is per-

forated, and abscesses have appeared in the soft parts. Before these changes have taken place, and previous to the perforation of the cartilage, the joint often becomes distended with fluid, due to the extension of the inflammation by contiguity of tissue. These attacks of synovitis are often of short duration at first, coming on after some injury or too much exercise; after a few days' rest they pass off, only to be repeated, however, on the repetition of the exciting cause. Soon the joint-swelling will come on upon less provocation, and the distention will be slower in disappearing, until finally the effusion will persist and the joint continue enlarged. In these cases the contents of the joint may slowly become purulent, so that when the tubercular abscess opens into the joint no further increase of the symptoms takes place. Tubercular deposit may take place in the synovial membrane as well as in the bone, and the two processes go on together.

Necrosed pieces of bone of varying size are frequently met with in connection with bone-tuberculosis; they often preserve some point of attachment to the bone; they are frequently of a wedge shape, with the base directed to the neighboring joint, while the apex looks towards the medullary cavity. Between the sequestrum and the healthy bone immediately surrounding it there is a layer of firm tubercular granulation which joins it to the bone, the latter being frequently diseased.<sup>1</sup>

A good result has been obtained in all varieties of tubercular disease of the ends of the bones except the infiltrating variety. It is produced only after the destruction of the part involved, by the discharge of the abscess through a sinus, if the deposit has marked necrotic changes, and later by the formation of cicatricial tissue. The firmer the granulation and the fewer the tubercles, the more likely is it to become replaced by firm fibrous tissue; the greater the softening, the more liability is there to suppuration and the more protracted is the course of the disease.

#### TUBERCULOSIS OF THE SYNOVIAL MEMBRANE.

Tuberculosis of the synovial membrane is a frequent disease in childhood. Formerly it went under the names of pulpy degeneration, white swelling, and tumor albus; more recent pathological research has demonstrated that it is a tubercular disease of the synovial membrane.

The earliest manifestation pathologically of tubercular disease of the synovial membrane consists in a swollen, opalescent condition of the membrane; it is filled with inflammatory products. The surface soon loses its smooth appearance, and by degrees assumes the aspect of granulation-tissue. As the disease progresses, the membrane becomes thickened, soft, and friable, and here and there, both in the membrane itself and in the subsynovial tissues, masses of caseous material are formed.<sup>2</sup>

When once established, the inflammatory process extends until the liga-

---

<sup>1</sup> Jones, *Diseases of the Bones*, p. 179.

<sup>2</sup> Marsh, *Diseases of the Joints*, p. 99.

ments, cartilage, and often the ends of the bones, are involved. As the disease of the synovial membrane advances, this semi-solid gelatinous tubercular material gradually extends, and slowly permeates all structures of the joint and fills its cavity. As soon as the cartilage is overlapped by this pulpy material, it loses its natural bluish-white tint and polished surface and becomes of a yellowish, dull, and opaque color. It soon undergoes erosion, slight at first, but these spots soon deepen until the underlying bone is reached or the synovial membrane acquires adhesions to its surface; vessels enter its substance, and a number of pits and excavations are formed containing granulation-tissues; these increase and unite, so that by degrees the bones become denuded and more or less diseased. This gelatinous material permeates and infiltrates all structures, and may extend to the tissues outside of the joint. Through this newly-formed tissue blood-vessels penetrate. In many cases abscesses form in this thickened tissue from caseous deposits, and open either within the joint or external to it. On opening such a joint when the disease is advanced, the whole cavity is found filled with this semi-transparent gelatinous material, the ligaments are swollen and softened, the cartilage is more or less destroyed, and the bones are diseased: in fact, every tissue of the articulation has been invaded by this pulpy material. Through this mass are frequently found collections of thin, unhealthy-looking pus. Outside of the joint the parts are also often infiltrated, of a pale, unhealthy color, and considerably swollen.

It is a slow, insidious disease, often ending in a general arthritis and in total destruction of the articulation, and even in death. Its exciting cause may be an injury, or it may come on without any apparent cause. It never makes its appearance except in those of a tubercular diathesis.

The general treatment of a child affected with joint-disease calls for but brief notice. The necessity for keeping the patient in as good a condition as possible is so well recognized that any remarks on the subject are needless. Tonics, fresh air, pleasant surroundings, and nutritious food are of incalculable benefit, and without them our best efforts at local treatment will be disappointing. We can give no medicine which will have any direct effect on the joint-affection: we can only influence it by attention to the health of the patient. It may be laid down as a rule that in children who are of low vital powers and whose general condition is depressed, joint-disease will progress no matter how rigidly the local treatment may be carried out; while, on the other hand, any improvement in the general health of the child will place him in a better condition to overcome the joint-disease. Suppuration is present in many cases; and a general consideration of the management of abscess is presented in another place.

The general symptoms of tubercular osteitis are limited motion, lameness, swelling, and deformity. These usually come on in the order named. In all cases of tubercular osteitis the joint, if affected, is involved secondarily; in certain cases it may escape infection. In the early stage of the affection we have to deal with only a bone-lesion, and the treatment of this



condition is the same as that of similar disease more distant from the joint. After the articulation has become involved another element is added, although the local management of the joint-trouble is the same as that of the bone-lesion. Disease beginning in the synovial membrane calls for the same management as disease beginning in the bone. Thus the treatment of joint-diseases may be considered collectively, and our main dependence must be placed upon affording to the affected articulation absolute rest. But consideration of the general treatment of joint-affection would be very incomplete without a clear understanding of the mechanism and therapeutic use of extension in the management of acute and chronic joint-diseases.

Spasm is one of the most constant and painful symptoms of inflammation of the larger joints, especially when the bones are involved: it is the cause of the painful startings so common during the course of the disease; it disturbs the rest of the patient, and is no small factor in keeping up and aggravating the local trouble. Although it is universally admitted that rest is an absolute necessity, yet, from the want of a clear understanding of what is meant by rest, the method of obtaining it is often very imperfectly carried out.

Mr. Marsh, in a chapter "On the prejudicial effects of intra-articular pressure, and on the danger of producing it by surgical appliances," in his work on "Diseases of the Joints," has so clearly spoken upon this subject that I cannot do better than make very free use of this chapter. He says, "All will accept the general proposition that rest is essential in treatment of inflammatory disease of the joints; yet there are some points which require to be insisted upon in order that the principle may be adequately carried out. There is present in all cases reflex contraction of the surrounding muscles. In the majority, however, it is only slight, and sufficient merely to secure more or less fixation and protection of the affected joint. Neither in the shoulder, wrist, elbow, nor ankle does it become excessive, so as to lead to either deformity or excessive pain. All the joints when first attacked are placed in their respective positions of greatest ease, and their positions are maintained undisturbed by muscular spasm through even long periods of active disease. In disease of the shoulder the arm remains at the side; the elbow is kept at an angle of about one hundred and twenty degrees; the wrist is slightly dropped; the ankle is fixed in a position of slight equinus. Both the hip and knee, however, offer a strong contrast to all these instances. They are liable to the influence of constant, and often violent, spasm in the surrounding muscles, which frequently leads to severe suffering and to irremediable deformity. To secure rest to a diseased joint, all its component structures must be taken into account, and the different sources of disturbances must be kept in view. The synovial membrane must not only be defended from mechanical disturbances by movements of the joint, which have the effect of dragging upon and compressing its swollen processes and fringes; it must also be relieved, as far as possible, of its function of secreting synovia; while if it becomes distended

by effusion, appropriate means must be taken to remove this condition. The articular ends of the bone must be in the same way relieved of their ordinary functions of sustaining the pressure to which they are exposed, not only when they are engaged in transmitting the weight of the body, but also during muscular action. . . . The tibia, in cases of the knee, for example, is a lever acted on by the surrounding muscles, and having the condyles of the thigh-bone as its fulcrum, and whenever the muscles contract so as to move the tibia its upper end is pressed against the femur. Hence to place the knee-joint at rest is necessary not only to protect the synovial membrane from disturbance, and to relieve it from the active discharge of its secreting functions and to prevent the patient from bearing weight on the limb, but also to remove the intra-articular pressure resulting from muscular contractions. . . .

“The conditions, however, under which a diseased joint is placed are widely different. Pressure depending upon superincumbent weight may, it is true, be removed by position, but, in consequence of reflex irritation, the muscles are kept in a state of contraction, which in the hip and knee is often so spasmodic and so violent that it is attended with extremely painful jumpings and startings of the whole limb. The force with which the muscles act exceeds normal contraction as pain exceeds natural sensation. . . . Its amount is indicated by the suffering it causes, when, as is often the case, the slightest movement of the limb or a light step across the floor or even in an adjoining room brings on a condition of spasm which makes the patient cry out with pain. . . . Under these circumstances the articular ends of the bone are not only deprived of the usual respite from pressure which constitutes their physiological rest, but, diseased as they are, and therefore so much the more in need of rest, they are exposed hour after hour, or even week after week, to an amount of pressure which is often in many cases in excess of that to which they would be exposed, except on very rare occasions, in the condition of health.

“Any scheme for treating the hip or knee, therefore, must include a provision for the relief of intra-articular pressure. There are at present two principal methods by which this may be attempted. (1) The joint may be placed in some form of rigid apparatus which prevents movement, and under the influence of which muscular spasms will subside. In all joints except the hip and knee, and in many instances in these also, this method is efficient and leaves nothing to be desired. . . . (2) Weight-extension may be employed. . . .

“Yet there lies at the bottom of the successful application of weight-extension a principle which is frequently overlooked, and the result is that, instead of acting so as to relieve intra-articular pressure by drawing the surface out of abnormally close contact, extension has exactly the opposite effect, for it brings the articular ends still more firmly together. (Fig. 1.) If the weight is attached to a limb that is in the position of extension, its tendency is to draw the joint-surfaces apart. In the majority of cases, how-



The first part of the report deals with the general situation of the country, and the progress of the war. It is a very interesting and valuable document, and one which should be read by every citizen of the United States.

The second part of the report deals with the military operations of the army, and the progress of the war. It is a very interesting and valuable document, and one which should be read by every citizen of the United States.

The third part of the report deals with the financial operations of the government, and the progress of the war. It is a very interesting and valuable document, and one which should be read by every citizen of the United States.

The fourth part of the report deals with the diplomatic operations of the government, and the progress of the war. It is a very interesting and valuable document, and one which should be read by every citizen of the United States.

The fifth part of the report deals with the internal operations of the government, and the progress of the war. It is a very interesting and valuable document, and one which should be read by every citizen of the United States.

The sixth part of the report deals with the external operations of the government, and the progress of the war. It is a very interesting and valuable document, and one which should be read by every citizen of the United States.

The seventh part of the report deals with the internal operations of the government, and the progress of the war. It is a very interesting and valuable document, and one which should be read by every citizen of the United States.

The eighth part of the report deals with the external operations of the government, and the progress of the war. It is a very interesting and valuable document, and one which should be read by every citizen of the United States.

The ninth part of the report deals with the internal operations of the government, and the progress of the war. It is a very interesting and valuable document, and one which should be read by every citizen of the United States.

The tenth part of the report deals with the external operations of the government, and the progress of the war. It is a very interesting and valuable document, and one which should be read by every citizen of the United States.

joint is healthy, and that the lameness is due to bands of adhesion either within or without the articulation. Joints that are suitable for manipulation are free from abnormal heat, or if any heat is present it follows exercise and rapidly subsides after rest. In many cases they are abnormally cold, and the skin is dark and mottled. There is often pain upon motion, and the parts are œdematous and swollen. It is often impossible to state just what is the condition of the parts, yet these are the cases which are cured by forcibly bending the joint. The operation is performed under an anæsthetic; gas may be used, but all muscular resistance must be abolished, so that the force is brought to bear upon the adhesions and their rupture can be easily appreciated. The joint should then be thoroughly flexed and extended. During this procedure the bands are often felt and even heard to give way. There is no after-pain. The patient soon regains painless use of the limb.

#### ABSCESS.

There is a great difference of opinion in regard to the proper management of abscess in connection with joint-disease, between those who confine themselves to the mechanical treatment of diseases of the articulation and the general surgeon. Many of the former allow abscesses to increase and burrow among the soft parts until they make an opening for themselves; the latter holds that they should be evacuated as soon as they are discovered, thoroughly drained, and treated like similar collections of matter in other locations.

Abscesses may be either intracapsular or extracapsular, or, as is more generally the case, they start within the articular cavity, in time perforate the capsule, and then burrow in the soft parts; they may in a few cases be extra-articular at first, but, as a rule, they soon communicate with the joint-cavity. The only exception to this is where there exists an abscess in the end of one or both of the bones forming the articulation, which has opened external to the capsule, and where the joint itself is affected only by contiguity of tissue and not by infection from the bone-abscess itself. But in whatever way these collections of pus may have formed, or wherever situated, only one course of treatment must be followed. It may be laid down as a rule that as soon as pus is formed in a joint it should be treated like an abscess in any other locality, and that its presence within the capsule does not in any way form an exception to the inflexible rule that it should be at once evacuated. An articular cavity containing pus is no longer to be looked upon as a serous sac: its functions as a joint have been destroyed, and it has been reduced to a cavity containing pus,—nothing more nor less; the simple fact being that we have a sac bounded by a dense inelastic wall, secreting purulent matter, which, sooner or later, will perforate its fibrous surroundings, form a new abscess among the soft parts, and finally open through the skin and discharge, after burrowing, it may be, for a considerable distance. There is no difference between an extracapsular and an intracapsular abscess, except that the latter is more serious and

more dangerous to the life and integrity of the articulation; and therefore, if pus in the soft parts demands active treatment, the same rule must hold good, with even greater force, in regard to collections of matter connected with joint-disease, whether they are acute, subacute, or chronic.

Mr. Marsh divides abscesses in connection with joint-disease into three classes. (1) The acute,—those which form in acute suppurative synovitis, in general arthritis, and in pyæmia. They are attended with high temperature and marked constitutional symptoms; they are sudden in their advent, and, if allowed to run an unrelieved course, destructive not only to the integrity of the joint involved, but often also to life itself. Acute abscess may form in the course of any chronic joint-trouble, either from injury or from the bursting of an abscess of the bone into the articulation. (2) Those that form later in the disease, and generally are connected with tubercular or non-tubercular disease of the bone. They are often slow in their formation, frequently unattended with any marked symptoms, with no great elevation of temperature, and with but little pain, especially those forming about the hip-joint. Yet, if careful investigation is made, a history of increased pain and exacerbation of the joint-disease may be made out. In the more superficial joints increased swelling and pain are often complained of. In other cases an evening elevation of temperature may be noted for some time, with more discomfort in going about, or even pain at night, and with swelling of the surrounding soft parts, often followed by a sudden diminution of the more acute symptoms as soon as the pus has perforated the capsule and diffused itself in the surrounding tissues. (3) Residual abscesses,—those which develop when all disease has subsided, and which involve the old inflammatory products, as the remains of an old abscess that has undergone caseous degeneration, etc. These may not make their appearance until months or even years after the disease of which they are the result has passed. They are often acute in their advent, attain considerable size if the pus is allowed to accumulate, and are attended with marked constitutional symptoms. These abscesses may also have their origin in the inflammatory products infiltrated in the soft parts, which have low vitality, and on the receipt of an injury, from failure of health or some unknown cause, break down, and an abscess of greater or less size results.

The course of an abscess in connection with joint-disease varies. When collections of pus are allowed to follow what is called their natural course, if they are intracapsular in the beginning a time will arrive when they will perforate the capsule and burrow in the soft parts, following often the muscular planes, and frequently extending far from the joint before they approach the surface and discharge. These cold abscesses sometimes contain a pint of pus; the soft parts are undermined; the muscles are dissected from one another and their nutrition is greatly impaired. The walls of such an abscess-cavity are thick, and lined with exudative material filled with spores, which tend to keep up the suppuration. When these abscesses have their origin in tubercular disease, they always contain the tubercle-

bacillus, and the danger of infection of other parts of the body is great. When recovery takes place after one of these abscesses has run its course, the muscles are bound down by adhesions,—it may be to the bone or to one another,—the limb is covered with scars, and its ultimate usefulness restricted. In some cases the abscess does not travel far before it makes an opening for itself and discharges. In superficial joints, as a rule, it soon perforates the skin, and continues to discharge through a small sinus for a long time. An abscess often takes on a more acute course. As the opening is small, either from granulations or from some other cause, it does not afford adequate drainage: the pus therefore accumulates, and the soft parts become inflamed and swollen, until either a new opening is formed or the old one is dilated. In this way the limb becomes riddled with sinuses and the skin undermined. One would be greatly criticised for not opening an abscess in the soft parts: why should he not be equally condemned for not giving exit to pus when it happens to be in or about a diseased joint? We often hear it claimed that because the collection of pus sometimes, if left alone, dries up and never gives further trouble, therefore all abscesses should be allowed to pursue their natural course. It is true that these abscesses sometimes cascate, but it is the exception and not the rule; and even when they do, their remains are always a source of danger, from the liability to the formation of residual abscesses.

The advocates of the let-alone management of collections of matter in connection with joint-disease look upon the presence of an abscess "as at least an evil attended with compensating advantages; their occurrence appears to shorten the duration of the affection. . . . There is no evidence that the discharge, as such, exhausts the strength of the patient."<sup>1</sup>

It is true that in some cases these abscesses disappear and the caseous deposit does not give any further trouble, but it is *not* the rule. It is within the experience of every one who has seen much of joint-diseases, to have had much trouble from these remains of old abscesses; and the fact should not be forgotten that these caseous deposits are able to infect the system,—that is, if they are similar to caseous deposits in connection with tubercular disease elsewhere. Again, amyloid degeneration holds a close relation to suppuration; at least we do not find this secondary change in the viscera except in cases that have gone on to suppuration. It is not intended to deny that abscesses in some patients do well,—that is, that a good recovery takes place; but the question is, is the let-alone plan a safe one to follow as a rule of practice, and is the constant discharge of pus through sinuses often long and numerous, the frequent formation of new abscesses, or the filling up of old ones, an advantage to the patient?

Suppuration, whether it is profuse or only slight, always tends to undermine the patient's health, and the larger the abscess the greater will be the suppuration after it has formed an opening for itself. The more one can

<sup>1</sup> Judson, New York Medical Journal, 1885, vol. xli. p. 116.

limit the amount of pus, the less will be the danger of hectic and amyloid degeneration, and the better will be the chance of recovery from the joint-disease. The fear of free incisions is due to the disastrous results which followed such procedures before the present method of wound-management was adopted, and statistics quoted to prove the danger of interfering with these collections of pus are misleading and prove nothing.

What, then, should be the treatment of abscesses in connection with joint-disease? *Whether they are intracapsular or extracapsular, they should be opened as soon as they are discovered, thoroughly drained, and treated according to the well-established rules of antiseptic surgery.* Marsh<sup>1</sup> makes the following statement in regard to abscesses: "That matter should be evacuated as soon as it is detected must be strongly advocated in all instances of suppuration resulting from serofulous disease."

The following is the method usually adopted in opening these abscesses. The parts around the abscess should be thoroughly washed and rendered aseptic by covering them with a towel wet with mercuric solution (one in one thousand) some time before the operation. An incision is made of ample size down to the abscess-cavity in such a position as to insure the best drainage; the cavity is then entered, well evacuated, and washed out at once; its walls are next thoroughly scraped with a Volkmann's spoon, so as to remove all the lining membrane of the sac; it should again be thoroughly flushed out with the antiseptic solution. If the abscess connects with the joint, that should also be cleaned out; any carious bone may be gouged and then washed out. If there are any sinuses, they should be well scraped, or, better, dissected out, so that no diseased tissue is left, and the abscess- and sinus-walls may unite and obliterate the old cavity. The drainage should be so arranged, if possible, that any discharge will not pass through the old cavity, and if the joint has been entered the drainage should be from the most dependent parts of that cavity, independent of the location of the abscess. The part may then be dusted with iodoform, drainage-tubes inserted, and the wound closed with catgut ligature. A strip of iodoform gauze should be laid over the line of the incision, and over this an ample dressing of antiseptic gauze, and the limb thoroughly immobilized.

Under this treatment it will be found that the temperature, if it has been elevated, will fall, the pain cease, and if the abscess is an acute one it may never give any further trouble. In case, however, it is connected with diseased bone, a sinus will remain; but we have gained this: that the pus from the joint will as fast as formed drain away by the shortest route, and if the drainage-tube is properly placed there should be no further accumulation of pus; this reduces the danger of the matter burrowing to a minimum, and the patient is saved the pain and discomfort of the formation of new abscesses. The dressings should be renewed as often as they become soiled.

<sup>1</sup> Diseases of the Joints, p. 115.



The after-history of these abscesses varies according to their causes. In some cases, if the abscess is acute and not connected with diseased bone, we may hope by proper treatment to evacuate the pus so that it will not again collect. In other cases, no matter what course is pursued, we must look for new accumulation until the disease of which it is the result has subsided. The latter are cases of chronic abscess, and are almost always connected with tubercular disease of bone, in which pus will continue to be formed—it may be only in small quantities—as long as the bone-disease lasts; or the abscess may be connected with necrotic or carious bone of a non-tubercular nature. The gain in treating these chronic abscesses is that we provide drainage to the joint by the most direct route, so that the pus does not collect, and therefore the patient escapes the disadvantage of large purulent collections, long sinuses, and increased suppurations.

Tubercular abscesses may be treated by emptying them through a thoroughly disinfected trocar and then injecting the cavity with a solution of iodoform and ether (five parts of iodoform to one hundred parts of ether). Abscesses treated in this way, if the bone-disease has terminated, may never refill. After evacuating the abscess an ounce or two of the solution is injected into the cavity, and then, gently kneading the parts in order to distribute it evenly, the rest is allowed to run out through the canula.

Poultices should never be applied to discharging abscesses; if these are acute or inflamed and the parts red and swollen, their condition is due to retention of pus from inadequate drainage, and a free incision will afford prompt relief. The use of poultices encourages suppuration, and is not permissible in antiseptic surgery.

---

## DISEASE OF THE HIP-JOINT.

Hip-joint disease in the natural sense of the term means no special complaint, but for years has been applied to a chronic tubercular affection of that articulation, very commonly met with in children. It has been called chronic articular arthritis, morbus coxarius, tubercular disease of the hip, coxalgia, etc.; but by whatever term it is designated it consists of a tubercular inflammation of the hip-joint.

It is met with among all classes during childhood. It may begin either in the bones or in the synovial membrane, is slow in its progress, and tends to the total destruction of the articulation. Its frequent occurrence, its insidious beginning, its disastrous tendency, and the varying views held by different practitioners as to its cause and management, contribute to make its study one of the most interesting and important of any articulation.

The disease, according to Gibney, is as frequent in girls as in boys: thus, out of four thousand one hundred and twenty-five cases of the affection

occurring in children under six years of age, two thousand and thirty-eight occurred in girls and two thousand and eighty-seven in boys. The trouble usually begins before the sixth year, although it is not uncommon in older children.

As stated above, hip-joint disease is a tubercular affection. It is never developed in healthy children, but always in those who, through inheritance or ill health, possess a certain vulnerability of their tissues, which hence furnish a soil congenial for the deposit of the tubercle-bacillus. That its exciting cause is often a fall, a wrench, or other injury to the joint is true, yet the disease never follows such traumatism in perfectly healthy children. In some cases it occurs without any assignable cause, not infrequently in those who have been confined to their beds for months.

In the vast majority of cases in children under six years of age the disease begins in the bone. Some surgeons look upon the ligamentum teres as the point of primary disease, but post-mortem examinations entirely disprove this theory. The hip-joint differs in two respects from any other articulation: first, the epiphysis and neck of the bone are entirely within the capsule of the joint; secondly, they are more isolated, and the supply of blood is more easily interfered with, than in any other articulation.

The disease has been divided into the femoral, the acetabular, and the synovial variety, according as the affection starts in one or other of these localities. But, whether it begins in one situation or another, its course, if not relieved, is slow and progressive until every structure in the joint is involved. It may begin in any portion of the bone, but usually begins in the head or neck,—not so frequently in the acetabulum.

As in other articulations, the tubercle follows one of three courses: it may infiltrate the bone, showing no tendency to become limited; there may be one or several foci surrounded by inflammatory exudation, which gradually break down, unite, and form tubercular abscesses of varying size, which may gradually, by absorption, inflammatory softening, or necrotic or carious changes, reach the outer shell of the bone and finally gain access to the joint; or the deposit may undergo a cicatrizing process, and recovery take place without any direct implication of the joint. According to the course pursued by the deposit will be the rapidity of the joint-infection or the tendency towards a cure.

In the first or infiltrating variety of tubercular infection, the joint is soon affected. These are the cases in which the disease advances so rapidly that its progress resembles that of malignant disease. The whole end of the bone becomes infiltrated, the inflammatory process often extends down into the shaft, and the patient soon dies of general exhaustion from the effects of deposits in other portions of the body.

In the second variety, in which the disease is at first limited to certain parts of the bone and surrounded by inflammatory deposit, whether bony or fibrous, its course is much slower. It may be months or even a year or more before the pus gains access to the joint. The contents of the abscess

may infect the limiting exudation and the bone be again infected from this point, so that the neck and head of the femur may become infiltrated as in the first variety, and the disease from this point pursue a rapid course. In those cases where the abscess slowly works its way to the surface of the bone, it often discharges through a small sinus either in the neck or through the articular cartilage. Within these cavities are frequently found sequestra of varying size. In the cicatricial variety the joint is never infected, and a cure takes place often with perfect motion. But all these varieties run into one another.

The factors which determine the course of the tubercular deposit, whether towards infiltration, a local necrosis, or cicatrization, are the amount of primary local infection, the general physical condition of the patient, and treatment. Recovery from bone-tuberculosis is always by the substitution of connective tissue for the tubercular. If, therefore, an abscess-cavity has formed, its contents must have been removed and replaced by connective tissue before recovery can take place; and this is always a slow process.

The appearance of the bone in hip-joint disease depends upon the variety and the stage of the affection. In the infiltrating variety the bone is filled with inflammatory products; the cancellous tissue is soft, spongy, and easily broken down under the fingers; the bone is of a dirty dark-red color; the periosteum is thickened and easily stripped off, exposing the surface of the bone, of a dark color. The articular cartilage is changed: sometimes it is detached in a mass; at other times the epiphysis lies loose in the joint-cavity, covered more or less with cartilage; again, there may remain islets of cartilage surrounded by granulations from the bone; in other cases it presents a worm-eaten appearance, with granulations protruding from the bone beneath. The synovial membrane is thickened, velvety on its inner surface, and perforated. The joint has become affected early, and is found filled with sanious pus, bony detritus, and sequestra. The trochanter major is often easily detached from its connection with the shaft. In fact, every tissue about the joint has become diseased. The same condition is seen in those cases that have advanced to total destruction of the part although the disease may have started as a local affection in the bone, the cancellous tissue having been infected from one or several small foci. In those cases where an abscess has formed and perforated the bone, forming an opening of varying size, the bone may never exhibit such extensive disease as mentioned above. There may be more or less loss of substance about the head and neck: thus, its upper segment may be destroyed, or the lower portion, with the under surface of the neck, may be deeply eroded; the inner portion of the head may be destroyed, leaving a shell of bone, the cartilage may show necrotic change, or there may be found only a sinus leading into a small cavity in the head or neck, the joint itself showing but a slight amount of disease. In fact, between these two extremes every shade of difference is found.

In cases of advanced disease the epiphysis may be entirely destroyed or may be detached and lie loose in the joint. Later in the disease nothing

may remain but the truncated end of the neck, the joint being filled with sequestra of varying size, sometimes representing the entire head of the bone denuded of cartilage and filled with granulations.

When the disease has existed for some time and is extensive, we may find that it has extended down the shaft as a chronic osteomyelitis. The appearance of the cut surface of the bone is characteristic; its compact tissue is greatly thinned at the expense of its inner shell, its color is dark, and the medullary cavity is filled with a soft, dirty yellowish-red material. The periosteum is easily stripped, so that the whole diaphysis can be extracted from its covering by simply pushing it up, leaving the periosteum intact. Sometimes the head and neck may be found detached; in such cases the end of the shaft is irregular and looks dark, with diseased medulla protruding from its central cavity. If a section is made lower down, the same condition will be found: the whole diaphysis is involved.

Disease may begin in the floor of the acetabulum: in these cases perforations may take place early. Recently there has been under my care a child, four years of age, who when first seen was supposed to have tubercular osteitis of the head of the femur. The spasmodic contractions of the muscles of the thigh were very frequent both day and night, and absolute rest and extension failed to relieve them. I therefore trephined through the trochanter major. This did not relieve the spasms, and I opened the joint, as there was evidence of pus in it. The articulation was found full of pus. The cartilage on the head was bright and apparently healthy. The acetabulum was extensively diseased, its floor was perforated, and there existed an intrapelvic abscess of considerable size. The head and neck were removed in order to afford drainage to the pelvic abscess. On section of the head it was found not involved in the disease. Cases are upon record in which the head and neck of the femur have passed into the pelvic cavity through the acetabulum, so extensive has been its destruction. Sometimes the primary focus of disease has been in the rim of the acetabulum.

In advanced disease changes in the shape of the acetabulum are often found; its upper portion is eroded, so that what remains of the head and neck of the femur occupies a higher plane than normal. Among the older writers we often find mention of dislocation of the head of the bone as a common result of chronic disease of the hip-joint. This is an error, probably due to the lack of post-mortem examinations. In the later stage of hip-joint disease the head is often flattened or destroyed in its upper segment; the action of the muscle is to draw the whole bone upward and backward, so that the upper border of the trochanter is placed upon a higher level than normal; at the same time the upper border of the rim of the acetabulum is eroded. Either or both of these conditions permit the trochanter to assume a position above Nélaton's line and thus simulate dislocation. True dislocation, however, is occasionally met with. When early in the course of the disease the ligamentum teres has been destroyed, and there is marked flexion and adduction, the head of the femur may be forced out of the cavity of the

acetabulum by muscular action. Some years ago a child was under my care with double hip-joint disease. On examining the patient one day it was found that the head of the bone upon one side could be thrown out on the dorsum and readily replaced. On post-mortem examination a few weeks later (the patient having died from uræmia), it was found that the ligamentum teres had been destroyed and that the head could easily be displaced upon the dorsum of the ilium. Gibney, in his work upon "Disease of the Hip," mentions having met with two cases of this complication.

Disease beginning in the trochanter major is mentioned by Annandale, Erichsen, and others. I have never met with it, and judge that in children it is very uncommon, from the fact that the trochanter is mainly cartilaginous until near puberty. The contents of a tubercular abscess in the neck of the femur may open outside of the capsule and the joint not become implicated, the condition being similar to an abscess in the condyles of the femur which has opened laterally and not towards the articulation. In such cases there may exist a cavity containing a sequestrum, a sinus discharging more or less pus being present. Hip-joint disease may begin in the synovial membrane, but more frequently begins in the bone. In the knee, on the other hand, tubercular inflammation of the synovial membrane is as frequent as that starting in the bone. Not long since, I had occasion to open a hip-joint in a child of six years, and found it filled with the granulations so often seen in tubercular synovitis of the knee-joint; the cartilage was only slightly affected, and there was no apparent disease of the bone, but the joint-cavity was filled and distended with this characteristic granulation-material and the capsule thickened. Gibney, although convinced of its occurrence, has never been able to prove it pathologically. If the disease advances, a time comes in the pathological history of the affection when the cartilage will have become perforated and more or less destroyed and the bone involved in the disease, so that on opening such a joint it will be impossible to state in what particular structure the disease began. Practically, so far as treatment is concerned, it makes no difference whether the affection has its origin in the synovial membrane or in the bone, and it is often impossible clinically to separate the two conditions.

Hip-joint disease may be divided into three stages. The first corresponds to the period of osteitis, the disease being limited to the bone; the second, to that in which the joint becomes infected; the third, to the perforation of the capsule, the formation of abscess in the soft parts, and the total destruction of the articulation. The first stage extends from the time of the deposit of tubercle in the bone to the time when the joint becomes infected, and pathologically corresponds to the period of osteitis. Its duration is variable, from a few months to a year or more, according to the acuteness or chronicity of the affection. Its symptoms are lameness, pain, altered position, limited motion, and muscular wasting. While in its later stage hip-joint disease is easy of diagnosis, its earlier symptoms are often overlooked or misinterpreted; yet if they are properly appreciated

they are as distinct and convincing as those of the second or those of the third stage. The symptoms will now be examined in detail.

#### SYMPTOMS.

**Lameness.**—One of the earliest and most constant symptoms of hip-joint disease, coming on often before the patient complains of any pain, is lameness. This lameness is peculiar. There is an element of stiffness about it. It may be only a slight favoring of the affected limb, a little awkwardness; the foot is not raised so high, and the step is shorter. The child seems to be careful of the limb. There is stiffness in the morning and the limp is then more marked, but diminishes after use of the limb. In other cases it may be in the evening that this symptom is most noticed. But, through all, the patient, although not complaining, seems to be careful of the limb. He does not stand upon it. This condition may continue for weeks or months; there may be times when lameness is more marked, a day or so, or even a week; then it will decrease, and the patient go about as before. There is something peculiar about this limp which is almost pathognomonic of the disease, and, although careful examination may not detect any other symptom, yet it is too often the forerunner of more pronounced and decided signs. With this condition of the limb there may be found slight flexion. It is a rule that persistent lameness or stiffness of a limb should always be looked upon with suspicion, and it is not to be lightly dismissed, for it is too often the first symptom of joint-trouble.

**Pain** varies greatly in amount: sometimes it is slight, at other times severe from the beginning. Sometimes it begins with the lameness, at other times it may be absent or almost absent for months. It may be referred to the hip or to the anterior and lateral parts of the thigh, but it is most commonly at the knee and front of the thigh, so that hip-joint disease is often mistaken for disease of the knee, and splint and blisters have been applied for disease of that articulation. Sometimes the pain is referred to one spot, as the inside of the knee or in front, but most frequently the patient cannot exactly locate it except that it is in the knee. There may be diffuse pain down the thigh. I have now a case under treatment in which the pain is in the course of the sciatic nerve. At times it is referred to the leg, or even to the foot. Pain is often so slight that the parents of the child will deny its existence. At other times it will overshadow all other symptoms; it may come and go; it is often attributed to "growing pains." It may come on suddenly while the patient is taking exercise, and be so severe that he will grasp the knee and cry out from suffering. There is one peculiarity about hip-joint disease: it is liable to exacerbations during which the pain and lameness are more pronounced; a fall or over-exertion may develop it; after rest for a short time the more acute symptoms remit, and the child's condition returns to that previous to exacerbation. In other cases pain will be marked almost from the first, the pain and lameness going together. Thus pain may be only an occasional or passing symptom, may be detected only

on passive motion, or may be violent even when the patient is at rest. The child will grasp the knee in order to steady the limb and thus relieve the suffering. These reflex pains are always in the course of the obturator and anterior crural and sciatic nerves. In some few cases pain is complained of in the joint itself. Pain is, as a rule, increased by pressure over the trochanter, in front over the capsule, or behind the trochanter major in advanced cases. In the course of the disease, in some cases earlier than in others, the patient is subject to painful startings of the limb at night; often as he is going off to sleep he is roused by starting of the limb accompanied by acute pains, so that he will wake up with a cry, or it may come on during deep sleep. The child will not be thoroughly roused, but will cry out. This soon passes off, but it may in time be followed by another attack, and this may be repeated many times during the night. The cry is so characteristic that it has been given the name of "osteitic cry," and, when present, is pathognomonic of joint-disease. It is caused by spasmodic contractions of the muscles of the thigh, which crowd the inflamed parts together. These painful startings may continue for weeks or months; they sometimes occur only during an exacerbation, or they may be more frequent at that time. Later in the disease lameness and pain may be almost constant.

**Altered Position.**—In the early stage of the disease the limb at first may be only slightly flexed; later this is more marked, and abduction and rotation outward are added. This is the position of lengthening of the older writers. The position is one of greatest ease. "Flexion relaxes the ilio-femoral ligament in front of the joint, abduction the ligamentum teres and the upper band of the ilio-femoral ligament, and rotation outward the inner band of the ilio-femoral ligament and the back of the capsule" (Marsh). Early in the disease changes take place in the shape of the fold of the nates, and there is flattening of the buttocks on the diseased side, due to actual flattening or relaxation of the gluteal muscles; abduction and rotation may also be an element in its causation. If one examines a child affected with hip-joint disease, it will be found that the fold of the nates is lower and that the buttocks are wider and more flabby on the diseased than on the sound side. If there is much flexion, while the patient is standing, the anterior curve of the spine in the lumbar region will be found increased (lordosis), due to arching forward of the lumbar spine in order to compensate for the flexion of the thigh. The explanation of this position and of the apparent lengthening of the limb in this stage and of its shortening in the later stage is clearly stated by Marsh as follows:

"As the patient cannot use the limb for progression when it is either flexed and abducted or flexed and adducted, he adopts certain compensatory positions which enable him to move about. Having lost the power, through stiffness of the hip, of moving the femur on the pelvis, he now moves the femur and pelvis together. By curving the lumbar spine forward (lordosis) he turns the pelvis on its transverse horizontal axis, so that

the knee points downward. To compensate for the abduction (Fig. 5), he draws up the sound side of the pelvis (Fig. 6), and thus depresses the affected side, with the result of bringing the femur inward towards the middle line. This movement, attended with curvature of the lumbar spine

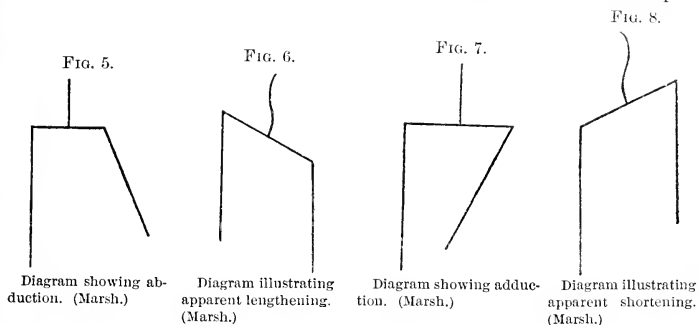

towards the diseased side, has by lowering that side of the pelvis the incidental effect of producing apparent lengthening of the affected limb (Fig. 6). If the limb is adducted (Fig. 7), the reverse occurs: the patient draws up the pelvis on the affected side, and so wheels the limb outward. This movement is attended with curvature of the lumbar spine with its concavity towards the diseased side and incidental apparent shortening (Fig. 8). This apparent lengthening is invariably the equivalent of abduction, and apparent shortening of adduction."

Real shortening does not belong to the first stage.

**Limitation of motion** is the most invariable, and, taken alone, the most conclusive, symptom of hip-joint disease. Its absence, except in the very earliest stage of the disease, is almost proof that hip-disease does not exist. In order to appreciate this symptom certain precautions and methods must be followed. The child's clothes should be entirely removed, and, after satisfying one's self that no disease of the spine exists, he should be laid upon a firm couch or some flat surface, so that the outline of the spine and limbs can be seen. The anterior superior spines of the ilium must be placed upon a level: normally, when a child is placed in such a position, the lumbar spine, the posterior aspect of the thigh and leg, and the heel should touch the couch; any change from this position is pathological. If, while the knee is down upon the couch, the lumbar spine, when the finger is placed under it, is found to be arched forward, flexion of the thigh upon the pelvis exists: the amount of flexion is ascertained by raising the thigh until the lumbar curve is obliterated; the angle which the thigh makes with the long axis of the body denotes the amount of deformity. Placing the iliac spines upon a level, the amount that the affected limb deviates in the direction either of abduction or of adduction from a line passing from the notch of the sternum through the symphysis pubis denotes the amount



of abduction or adduction present, or, what amounts to the same thing, moving the suspected thigh outward or inward until the anterior superior spines of the ilium are level.

Having thus determined the presence or absence of flexion, abduction, and adduction, the amount of motion at the hip-joint should be tested. With the knee a little bent, first flex while you abduct or adduct the sound limb to its fullest extent, in order that any slight deviation from the normal may be detected in the suspected one; next carry the suspected limb up on to the abdomen towards extreme flexion, and note carefully whether there is any resistance or pain (the sound limb being kept flat on the couch). Do this gently; never use force. Then test the movements in other directions,—abduction or adduction, whether inward or outward,—and note the presence or absence of resistance. As soon as the limb is grasped it will be found that the slightest resistance can be appreciated. If flexion is limited, no matter how slightly, even if the other movements of the joint are normal, hip-disease in its early stage must be suspected; if in addition motion is limited in any other direction, the inference is almost certain. Next to flexion, limited rotation is an important symptom; but resistance in any direction has the same value.

The joint must now be tested as to its sensitiveness and smoothness of motion; this should be done with the greatest gentleness; the old method of striking the sole of the foot to find out if there is any pain in the joint is as useless as it is barbarous. If there is disease about the hip, such methods are sure to aggravate it.

Limited motion is not peculiar to hip-joint disease; certain conditions outside of the articulation may cause it. Thus, a psoas abscess, an inflamed bursa, a gluteal abscess, or disease of the upper end of the femur, may prevent free motion. In such cases Marsh advocates the following method. "Flex the limb to an angle of one hundred and twenty degrees with the trunk; if rotation is unimpaired, so that the smooth head of the femur turns freely in the acetabulum, it may safely be concluded that the loss of other movements depends upon some condition external to the joint, while if rotation is deficient it will tend to show that the joint itself is affected." I do not think, however, that this test is as reliable in the early as in a later stage of the disease.

**Muscular wasting** is a very constant and important symptom, but it varies much in different cases. Sometimes it comes on early and is marked; at other times it is later in its advent, but, as a rule, some muscular atrophy is present among the earlier symptoms. It escapes notice because not carefully looked for.

Atrophy may be noted early and be marked, or may be slight until the second or third stage of the disease is reached, but it is almost always present; it may be detected by comparing the two sides, by the flabbiness of the muscles of the affected limb, or by actual measurement of the two limbs upon the same level. During the exacerbation the atrophy is apt to in-

crease more rapidly (Gibney). In the second and third stages of the disease it is marked, so that the bones seem to be covered only with skin.

These symptoms,—lameness, pain, limited motion, muscular atrophy, osteitic cry,—taken together, make up a group which, when present, can leave no doubt as to the existence of serious joint-disease. In the early stage many of them are absent, but a history of persistent lameness, no matter how slight or how intermittent, with muscular resistance to passive motion, points almost conclusively to osteitis in the head or neck of the femur, and unless the disease is checked the other symptoms mentioned above will follow, and these constitute what is called the first stage of the disease. The time that these signs may continue without any apparently marked change is often measured by months or even a year; there may be but little to draw one's attention to the joint, beyond a slight limp or an occasional attack of pain, so that one is sometimes at a loss to account for the lameness.

Pathologically the first stage corresponds with osteitis of the head or neck of the bone before the joint becomes infected. There may, however, be attacks of pain accompanied by an increase of fluid in the capsule due to irritation, but it is not purulent, at least at first, nor tubercular. The early attacks of synovitis pass off after a few days' rest, but if they are frequent, and the bone-abscess is approaching the free border of the bone, the effusion may not pass off, but persist, and the joint be permanently enlarged. Exacerbations are not uncommon, during which the pain, tenderness, and limping will be increased for a time; with these the joint will also be found to be swollen; after rest for a few days these symptoms will subside, the parts will return to their former condition, and the disease will pursue its old course. An exacerbation may be brought on by a fall or by over-exercise. If one sees a patient first during one of these exacerbations, he may be mistaken as to the stage of the disease, thinking that it is more advanced than it really is.

The second stage corresponds pathologically to the extension of the tubercular disease from the bone to the joint. The articulation may have suffered from serous effusion during the first stage, but in this it is actually infected. This stage may come on slowly, the lameness, muscular spasms, and pain gradually increasing, the joint becoming more fixed, and the limb more useless; or these symptoms may suddenly become more marked, the limb being held fixed, and the patient suddenly developing marked and persistent lameness. In this stage the joint will be found to be swollen, either in front of or behind the trochanter major, and at a later period abscess may be discovered starting from the back of the joint or in front. All the symptoms of the first stage are increased: muscular spasms at night are more frequent, and the child shows in his face the effects of his suffering. During this stage abduction is often changed to adduction; yet there is no rule about it; but we generally find the limb apparently shortened, considerably flexed, and fixed. Later, abscesses appear, and actual shortening begins to show itself.

The third and last stage of hip-joint disease corresponds to changes in the bone, real shortening, the increase of abscess, and total disorganization of the joint. The limb is now fixed, strongly flexed, and adducted and rotated outward, although in a few cases the opposite is found, due probably

FIG. 9.

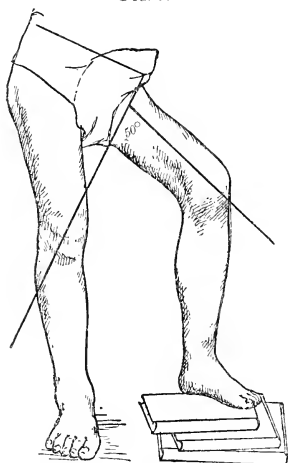

A case of abduction. (Poore.)

to position in bed, the patient keeping the limb flexed, rotated outward, and adducted. (Fig. 9 illustrates a case under my care.) This is the stage of true shortening, due to actual loss of substance in the head and neck and elongation of the upper border of the acetabulum. To this may be added atrophy of the bone from disuse. There is hardly any limit to the changes that may take place in the bone in this stage,—the head and neck gone, the acetabulum perforated, the pelvic bones involved in disease, and abscesses burrowing in almost every direction.

**Abscess.**—There are but few cases of hip-joint disease which have advanced to the third stage in which the pus does not perforate the capsule and appear among the muscles. The symptoms of the formation of abscesses are often vague and obscure. It is stated by some that

they give no warning of their advent. This is an error, for, although the signs may not be marked, yet, if careful inquiry be made, one will get a history of increased pain, more restlessness at night, and less inclination, if the patient is up, to move about, occurring some weeks or months before the discovery of the abscess. If at the times when the child exhibited this increased pain a careful examination had been made, a fulness might have been detected either behind the trochanter or in the joint in which the abscess began. In some cases the symptoms of the formation of an abscess are increased pain, a rise of a few degrees in the temperature, a fulness in the upper part of the thigh, and a decline in the general condition of the patient. Acute abscesses may also be found in connection with chronic disease of the hip. An increase in the size of the thigh is almost positive proof of the existence of an abscess. All abscesses do not come to the surface. Suppuration may take place in a joint and even perforate the capsule, yet by absorption and caseation the fluid contents may disappear, giving no further trouble, or reappearing at some future day as a residual abscess.

The thermometer is not a reliable guide as to the formation of abscesses in connection with this disease unless they are acute. They then give the same symptoms as similar abscesses in other parts of the body. In some cases I

have found a slight elevation of temperature in connection with increased restlessness at night and pain, which has denoted the commencement of an abscess, or rather its extension, and would therefore consider an evening elevation of temperature suspicious and probably as pointing to increased suppuration. That some of these abscesses form very slowly and give no indication by any increased temperature is also certain, so that the absence of fever is not a proof that an abscess is not forming.

When abscesses are small and deeply seated, they may be detected by the presence of deep-seated resistance to pressure or of a circumscribed swelling about the joint. When formed in the joint-cavity, the pus may after perforating the capsule burrow in various directions: it may perforate the capsule in front just below Poupart's ligament, and may then travel down the thigh, or follow the sheath of the psoas muscle into the pelvis and discharge through the rectum; it may pass out of the joint posteriorly, and burrow beneath the gluteal muscles or down behind the tensor vaginae femoris, appear in the perineum, or enter the pelvis along the track of the external rotators; in fact, it may follow the plane of any of the muscles and come to the surface far from the joint. In cases of long standing when the bones are profoundly diseased, abscesses may open in many places, so that the skin about the hip will be undermined and riddled with sinuses, which continually discharge unhealthy pus. Abscesses sometimes form within the pelvis from disease of the floor of the acetabulum, or enter it from the joint through a perforation of that portion of the pelvis. Intrapelvic abscesses are outside the obturator fascia; the pus makes a cavity for itself by stripping this membrane from the bone. When these collections of matter are of any size, they may be detected by rectal examination. The course of these intrapelvic abscesses is various; as they enlarge they may come forward, and can be felt under and above Poupart's ligament or by dipping the finger down from above into the pelvic cavity; they may open into the rectum or bladder; or they may come down the psoas muscle. Whatever may be their course, they are serious complications, not only from the difficulty of draining them, but also from the fact that they denote disease of the pelvic bones.

Thickening of the trochanter major is considered by many writers a most certain indication of suppuration within the joint. In order to appreciate it, the trochanter should be grasped between the fingers and thumb and compared with that of the sound side; if thickening is present it will, with one or two exceptions, be always found that there is pus in the joint. The exceptions are cases of spinal, sacro-iliac, or pelvic abscess which have burrowed down around the trochanter, and cases of disease of the upper end of the femur, etc., outside of the joint.<sup>1</sup> Barwell mentions the same symptoms.

When destruction of the joint has taken place, grating may be discovered

<sup>1</sup> Wright, *op. cit.*, p. 57.

in some cases. Its presence is a certain sign of the existence of diseased bone. Yet there are many cases in which, though the cartilage on the femoral and pelvic portions of the joint is destroyed, crepitus cannot be produced, from the fact that the denuded bones are separated by granulations springing from the capsule and bone, or from the fact that only one part of the bone is denuded.

**Quiet Disease.**—There is a form of hip-joint affection which Marsh describes under the name of “quiet disease,” not infrequently met with. These cases are characterized by an absence of some of the most prominent symptoms of the disease as usually met. They are liable to be overlooked by both parents and physicians until the joint has been completely crippled. There is no pain to attract attention, no tenderness, and but slight swelling. The main symptom is slowly-increasing stiffness. Children are often seen who have been brought for advice not because of any pain, but because the joint has become stiff, the child going about without any inconvenience except lameness from inability to move the articulation. In other cases the symptoms are a little more marked, yet not enough to cause much complaint. The children are brought because of some swelling about the thigh, and on examination an abscess is found, and perhaps disorganization of the joint. Between these cases and those following the more common course there is every shade of difference. It must be remembered that the amount of pain and discomfort varies greatly in different cases. In some the suffering is severe almost from the very commencement of the affection, while in others the amount of discomfort is slight. In both classes the disease tends to go on to total destruction of the joint.

#### DIAGNOSIS.

The diagnosis of hip-joint disease in its advanced stages is based upon a set of symptoms which taken together form a picture that leaves us in no doubt as to what we have to deal with. In its early stage it is often extremely difficult to arrive at a satisfactory conclusion from the few symptoms present, owing to their apparent variability and often to our inability to obtain a reliable history of the patient from want of observation and often ignorance of the parents. As stated before, persistent lameness, or even a history of transient lameness coming on after exercise, persisting for some time, and then passing off, to reappear again under similar circumstances, or a certain stiffness in the morning, disappearing in a few hours, only to be found again the next day, is not to be treated slightly. If pain is added to this, no matter how slight or how intermitting it may be, we have an additional proof; and if with this there is resistance to passive motion, we have all the symptoms that go to make up the first stage of hip-joint disease.

This stage may last for months, or even for a year or more, so that the parents or even the surgeon may think that an error has been made, and if treatment has been begun it is sometimes abandoned, and one realizes the mis-

take only when an abscess is discovered and it is suddenly found that other and more profound symptoms have made their appearance. The early diagnosis of hip-joint disease is of great importance, for by treatment we may hope to cure the affection in the bone before the joint has become involved.

There are certain diseases which may be mistaken for hip-joint disease, or for which it may be taken. These are muscular rheumatism about the hip, bursitis, contusions or sprains, neuroses of the hip-joint, infantile paralysis, perinephritis (Gibney), vertebral osteitis, sacro-iliac disease, and congenital dislocation of the hip-joint.

**Muscular rheumatism** from cold and over-fatigue gives symptoms that may cause it to be mistaken for hip-joint disease. The suddenness of the attack without any premonitions, the helplessness of the patient in locomotion, the acuteness of the pain on active movement and its absence or great mitigation when the patient is at rest, with the absence of tenderness and atrophy of the limb, give a history that does not belong to articular osteitis. The pain and lameness come together; the motion at the hip is free and smooth, with no muscular resistance.

**Bursitis.**—There are certain bursæ about the hip which sometimes become inflamed and simulate disease of the joint. Thus, a large one lies between the tendon of the iliac and the capsular ligament; it often communicates with the synovial cavity. Between the gluteus medius and the trochanter major is a small bursa; there is one of large size between the tendon of the gluteus minimus and the front of the trochanter; another between the gluteus maximus and the vastus externus, over which rides the strong fascia of the buttock; one also between the gluteus maximus and the trochanter major. These are the principal bursæ. The cause of bursitis may be a fall or sprain and cold (Gibney). The symptoms are some pain and tenderness referred to the location of one of these bursæ, an absence of pain and muscular resistance on passive motion, and a marked swelling in the situation of the bursa.

**Contusions and sprains** about the hip have been mistaken for hip-joint disease. The history of a fall or sprain, the rapid appearance of the pain, and the acuteness of the attack, should prevent the error.

**Neuroses** of the hip-joint are not infrequent, and present one of the most difficult problems in diagnosis, and in some cases it is impossible to separate the two, for there may exist disease of this articulation with marked neural symptoms. Hysterical joints are found among young children as well as in adults. Patients with hysterical joints always belong to neurotic families. The pain complained of will be out of all proportion to that due to disease of the hip-joint. There is marked hyperæsthesia of the skin about the joint, or, it may be, of the whole limb; there is often tenderness upon pressure over the spinal processes of the lumbar vertebræ; there may even be swelling about the joint (Gibney). Notwithstanding these symptoms, the limb, as a rule, looks plump and well nourished. There may be, and often is, fixation of the articulation, but, if the patient's attention is drawn

off while the examination is being made, the limb can be freely moved, and that without any pain. The starting-point of a neurotic affection of the hip-joint may be an injury, and the pain and lameness come on together, and are more acute, according to the patient's statement, than is the case in true hip-joint disease. The limb is flexed and often cold and blue. These patients do not complain of pain at night, as in disease of the hip-joint. The surface of the joint is often exquisitely sensitive to the touch. This is not found in articular inflammation. These exaggerated sensations and the general condition of the patient—the plump and healthy appearance—should be relied upon to separate neurotic affections from true hip-joint disease.

**Infantile paralysis** should never be mistaken for hip-disease: the acute onset of the symptoms, often with fever, the absence of spasm or contraction of muscles, the free motion of the joint, and later the marked atrophy in certain muscles, as well as the absence of pain, and the coldness of the whole limb, should prevent it from being taken for any joint-affection.

**Periarthritis** (Gibney) is not a common affection. Cellulitis among the muscles is an acute affection accompanied by local pain and marked constitutional symptoms, but it does not present the signs nor run the chronic course of articular inflammation.

**Vertebral caries** is more often mistaken for hip-disease than any other lesion, especially when the lumbar portion of the spine is affected. The pain may be referred to the knee, thigh, or hip-joint; there may be present marked lameness, with flexion of the thigh on the pelvis, especially if there is an abscess in the psoas muscle; there is atrophy of the limb. A child with vertebral disease can stand as well upon the suspected limb as upon the sound one; there is a stiffness in his carriage that is not seen in hip-joint disease; there is an absence of reflex spasms of the muscles of the thigh; the patient suffers greater increase of pain when he assumes the erect position and experiences more relief when in the horizontal position than in coxitis. On passive motion the head of the femur moves smoothly, and there is no muscular resistance except when the psoas is involved. When deformity of the spine is present there can be no question as to the diagnosis. It is a rule always to examine the spine in all suspected cases of hip-joint disease. As to the more special symptoms of spinal disease the reader is referred to the article upon that subject.

**Disease of the Sacro-Iliac Joint.**—Disease of this articulation may simulate hip-joint affection. Gibney questions its existence except as a secondary affection. It would seem that the question whether it is a primary or a secondary affection turns upon the fact whether disease beginning in the bone just beneath the cartilage is to be considered primary or secondary disease of an articulation, and whether disease ever begins in the articulation itself. Marsh<sup>1</sup> records a case in which the joint was in a condi-

<sup>1</sup> Op. cit., p. 366.

tion of "pulpy thickening" and was bathed in "curdy pus." Barwell considers that some of these cases are low-down Pott's disease. Van Hook<sup>1</sup> has collected cases of tubercular disease of this articulation occurring in childhood. It would seem that disease beginning in the bone just beneath the cartilage holds the same relation to the joint as hip-joint disease beginning in the head or neck of the femur, and, although in these cases the joint is secondarily affected, we practically consider articular osteitis a joint-affection. The same rule should apply to disease of the sacro-iliac joint beginning just beneath the cartilage, while cases of low-down Pott's disease which has extended to this joint may be looked upon as secondary.

That the cartilage, or rather that tissue in the sacro-iliac synchondrosis which represents a synovial membrane in other articulations, may be the seat of disease, is accepted by surgeons. But, whatever view may be adopted, the fact that there is an affection in or about the joint between the sacrum and the ilium which may be mistaken for disease of the hip is universally admitted. Marsh states that "it is probably for the most part scrofulous in its origin, but it is sometimes the result of injury in previously healthy subjects. . . . The changes that occur in the articulations may involve mainly the synovial membrane in the form of chronic inflammation and pulpy degeneration resembling that which is met with in the knee and other joints. In other cases the bones appear to be the parts that are first attacked,"<sup>2</sup> while in still others the disease extends from disease of the pelvic bones or the sacrum. There are, therefore, two classes of the affection, one in which the disease begins in the joint itself, or in close proximity to it, the other where the disease has extended to the articulation from some distance. But in whatever way the articulation has become affected, abscesses in time form, either within or external to the pelvis or in both localities, and the joint becomes completely disorganized. If an opening has been formed or is made to evacuate an abscess, it will be found that a probe can be passed into and through the joint. When abscesses have formed, if they are intrapelvic they may make their way down to the thigh or backward, if extrapelvic they appear as a swelling over the articulation.

The symptoms of sacro-iliac disease are variable, and apt to be confounded with those of affections of the hip or of the spine. They are pain, lameness, swelling, and abscess, and some writers add alteration in the shape of the parts.

Pain is a constant symptom, and is usually well marked; it is often severe, especially when the patient bears any weight upon the affected side, or on any motion communicated to the joint; in some cases, however, only a sensation of uneasiness or discomfort is felt about the parts. The pain may be in the joint or may be referred to a distant part; in the latter case it is down the limb in the distribution of the sciatic or the anterior crural nerve, thus simulating hip-joint disease.

<sup>1</sup> Annals of Surgery, 1888, vol. viii. p. 401.

<sup>2</sup> Op. cit., p. 301.



Lameness is always met with ; early in the disease it may be slight ; the patient complains of a feeling of insecurity about his hip, or it may appear only after exercise ; in marked cases locomotion is impossible. In standing, the whole weight is thrown upon the sound limb. There is tenderness on pressure over the joint, and sometimes there is a diffuse tenderness over the whole gluteal region. There is in time some swelling over the joint, depending upon the amount of suppuration present. In the early stage a slight swelling directly over the articulation may be discovered on careful examination. Alteration in the shape of the hip is mentioned by many, due to extrapelvic abscess, and later in the disease to atrophy of the muscles. The motion at the hip-joint is smooth, free, and painless if care be taken that no motion is conveyed to the sacro-iliac joint. There may be some flexion if there is a psoas abscess. The thigh is usually fully extended, and there is no shortening.

The diagnosis between this disease and that of the hip-joint requires much care. Lameness is common to both affections ; the pain often simulates that of disease of the hip. If, however, pressing the two iliac bones together or apart from each other, or trying to tilt the ilium on the suspected side upward or downward, the hip-joint not being fixed, causes pain, this points to the sacro-iliac articulation as the location of the trouble. Free, painless motion at the hip-joint will exclude that articulation. Swelling in the gluteal region is not positive proof of disease of the ilium, as it may be due to coxalgia : even the presence of tenderness in this region cannot be entirely relied upon. It is only by exclusion that a correct diagnosis can be arrived at. If there is no disease of the hip or lower portion of the spine, and the symptoms mentioned above are found, there is strong probability that the sacro-iliac articulation is affected, especially if pain is caused or increased by crowding the ilii together. The presence of an abscess with a sinus leading into the joint is proof positive of the existence of disease.

The treatment of disease of the sacro-iliac articulation in its early stage is absolute rest to the parts ; the patient experiences relief from the application of a firm bandage over the pelvis which holds the parts at rest ; extension with a light weight, steadying the thigh and pelvis, may be an advantage. If abscesses exist outside of the pelvic cavity, they should be opened, the diseased tissue removed, the parts thoroughly disinfected, and the wound dressed antiseptically. The management of an intrapelvic collection of pus is more difficult, especially if there is no external abscess ; but even here, if one is satisfied that there is disease of the joint, a removal of the cartilage would afford drainage, and frequent washing out with an antiseptic solution might bring about a cure. Van Hook<sup>1</sup> adopted a method of draining an intrapelvic abscess by entering the pelvis through the posterior superior spinous process of the ilium. "The patient lying on

---

<sup>1</sup> Annals of Surgery, February, 1889, p. 126.

the unaffected side, with the thighs in exaggerated flexion on the pelvis, an incision two or three inches long will expose to view the posterior superior spinous process of the ilium, which should be freed from periosteum and tendinous connective tissue by scraping with a blunt instrument; a chisel is then used to remove successive small fragments from the exposed bone, always holding the chisel edge parallel to the spinous process, till the finger can enter the cavity of the pelvis major and palpate the surface of the diseased bone." This would certainly give access to the abscess, and from its position would afford good drainage.

If there is much disease of the pelvic bones, however, not much improvement is to be expected from any method of treatment.

**Congenital dislocation** of the hip should never be mistaken for inflammatory affections of that articulation: the absence of pain, the peculiar walk, the change of position of the head in locomotion, present nothing in common with hip-joint disease. Perityphlitis and perinephritis may sometimes cause flexion of the thigh and pain in the distribution of the nerves having their origin in the sacral and lumbar plexus, from the presence of an abscess pressing upon them; but an examination of the symptoms and a study of the history of such cases will clear up any doubt.

A psoas abscess may open into the hip-joint and set up acute arthritis. It is, however, rare.

#### TREATMENT.

There are certain wrong impressions held by some in regard to the treatment of hip-joint disease which require a passing notice.

First, in regard to the effect of extension. At one time it was held, and by some it is still believed, that by extension the joint-surfaces are separated from one another. This is an error. Bradford<sup>1</sup> made some experiments upon the cadaver of a child ten years of age, and demonstrated that with one hundred and fifty pounds' extending force applied to the limb, the pelvis being fixed, no separation of the joint-surfaces took place. It is evident from this that in the first stage of hip-joint disease, and until the joint has become disorganized, no separation can be caused between the acetabulum and the head of the bone. The effect of extension in hip-joint disease is to steady the muscles and prevent spasm.

Secondly, in regard to motion. It is claimed by some that by extending the limb by the use of a splint, motion at the coxo-femoral articulation is not only not a disadvantage, but even a positive benefit. In the first place, it is an impossibility so to extend a limb that the joint-surfaces will not be in contact; and, secondly, if it could be accomplished, movement would cause an increased flow of blood to the parts and increase local congestion.

It is a mistake to suppose that the treatment of hip-joint disease differs in any respect from that of disease of other articulations; only its forma-

<sup>1</sup> Boston Medical and Surgical Journal, 1880, vol. ciii. p. 465.

tion makes the carrying out of the general indications in the management of joint-affections different.

The intelligent treatment of hip-joint disease must be based upon clear views of its pathology.

In the early stage of the affection when beginning in the bone, we have to do with a tubercular deposit in the neck and head of the femur or in the acetabulum. All subsequent changes in the bones and joint have for their starting-point this neoplasm. The deposit follows one of two courses: either it extends and further infects the bone, this extension and infection being accompanied by inflammatory and necrotic changes, or it becomes the seat of connective-tissue metamorphosis and ceases to act as a source of danger. The indications for treatment, therefore, during the first stage are to prevent extension of the disease, and to further the change of the deposit into connective tissue.

In the second stage of the disease the joint has become infected, and we have to do with a tubercular osteitis of the bone and inflammation of the joint. Here our treatment must be directed towards protecting the parts from all sources of irritation, so that repair may be effected by the replacing of the losses from disease by fibrous tissue.

In the third stage, after the joint has become disorganized and the bones necrotic and carious, and abscesses have formed, the indications are to promote the removal of diseased tissue, so that repair can take place.

In disease beginning in the synovial membrane the same indications hold good.

In the constitutional treatment every means should be adopted to improve the general health of the patient. The use of the different preparations of iron, cod-liver oil, and good generous diet, as well as being out of doors in the fresh air and sunshine, if the necessary exertion does not interfere with the local management of the disease, are called for. The indication for the local treatment of chronic tubercular disease of the hip, whether it begins in the bones or in the synovial membrane, is *absolute rest* to the joint, and on this point there is scarcely any difference of opinion among those who have to treat this affection. How best to attain this end has received different interpretations.

In regard to the management of inflammation of other articulations there has always been a unanimity of opinion. Take, for instance, the knee-joint. When it is diseased the method of fixation is well known and always thoroughly carried out. The articulation at the hip differs from that of other joints, except the shoulder, in that a long bone, the femur, is attached to a comparatively short bone, the ilium, so that there is an immense leverage brought by the thigh acting as the long arm of a powerful lever upon the pelvis through the head of the bone as a fulcrum. It becomes, therefore, a difficult matter to keep the joint absolutely at rest. Any device that does not completely fix the joint is so far defective. Take, for instance, the usual method of treatment by weight and pulley as gener-

ally applied. When the child is flat on his back the joint is fixed and at rest, but as soon as he sits up in bed movement takes place at the hip-joint in the direction of flexion, and absolute rest is not obtained. A knee-joint would not be considered fixed if, every time the child sat up in bed, motion, even over a small arch, took place; yet this is the condition in the vast majority of cases of hip-joint disease treated by weight and pulley. Every time the child sits up the thigh is flexed upon the pelvis, no matter how much weight is applied. It is said that the flexion does not take place at the hip, but by the bending of the spine in the lumbar region. The deformity in hip-joint disease is always towards flexion; if, therefore, the child sits up in bed, the limb will naturally become further bent upon the pelvis, and motion in the joint will take place. When the disease is treated by a hip-splint of the usual form, in many cases which are not properly attended to, motion is not absolutely prevented, and the joint is not placed in a condition of absolute rest. In the first stage of hip-joint disease beginning in the bone, tubercular foci have formed, and the treatment must be that of similar deposits in other bones. "Among the therapeutic means which exert a beneficial influence on the course of tubercle in bones, absolute rest of the parts holds the foremost position."<sup>1</sup>

This does not mean the application of extension and then allowing the little patient to sit up in bed and twist around all he can; nor does it mean the adjustment of a brace and then permitting the child to go about as much as he wishes or is able. It means *absolute fixation* and rest of the joint, so that *all* motion is abolished and all muscular spasm restrained. This may be accomplished by extension properly applied, and any abnormal position into which the limb has been brought may be as soon as possible corrected.

The deformity in hip-joint disease is in the direction of flexion and abduction or adduction. Abduction, if it is not marked, is not a serious deformity, because it causes an apparent lengthening of the limb by compelling the patient to lower the pelvis on the affected side in order to bring the foot to the ground. Adduction, on the other hand, by forcing the limb of the affected side across the sound one, compels the patient to raise the pelvis upon the diseased side at every step in order to get it out of the way; this is accomplished by the hitching motion so characteristic of the disease; it is also a fatiguing method of walking. Flexion, unless it is marked, is not so maiming a malposition as adduction.

Extension should be applied in the following manner. The patient must be placed upon a hard mattress; the pillow should be small and not raised too high; the trunk must be kept horizontal. The extension plaster should extend well up on the thigh, so as not to drag upon the knee, and should be secured by a smoothly-applied bandage. The child must be prevented from sitting up, and this is best accomplished by the application of a long

---

<sup>1</sup> Jones, Disease of the Bones, p. 183.

splint extending from the axilla to the middle of the leg upon the opposite side of the body from that diseased. It is well also to confine the shoulder by a firm band passing around the chest and fastened to the head of the bed. If there exists any flexion or adduction, it should be overcome by applying the extending force in the long axis of the limb as flexed, by raising it upon an inclined plane until the spinous processes of the lumbar vertebrae touch the bed and gradually changing the angle of the inclined plane as the flexion is overcome. To correct the abduction or adduction the limb must be moved outward or inward until the anterior superior spinous processes of the ilium are upon the same transverse plane. The amount of weight necessary to accomplish this is from three to eight pounds, according to the age of the child. By this method the flexion, abduction, or adduction is overcome, and as the deformity is diminished the angle at which the extending force is applied is gradually changed until all malpositions are corrected. The time necessary to accomplish this varies according to the amount of deformity and the length of time that the malposition has existed. This method does not increase the intra-articular pressure; it relieves the spasm of the muscles and gives to the joint absolute rest, thus placing the parts in the best possible condition.

The treatment of hip-joint disease cannot begin too early. As soon as a diagnosis is made the joint must be put at absolute rest. Often it is necessary to hold the pelvis up on the sound side so as to keep it straight. This is done by passing a band around the sound thigh and then carrying one end under and the other over the body and tying it securely to the head of the bed. We thus have an extending and a counter-extending force. It is usual to disregard abduction, as it will take care of itself if the joint retains its use, and if not it is an advantage rather than otherwise. The object of thus fixing the limb is to limit the disease in the bone by allaying all irritation and relieving local congestion of the parts.

The necessity for absolute rest cannot be too earnestly insisted upon. The child should *never be allowed to sit up in bed*: such a position always flexes the thigh upon the pelvis; it also increases the amount of irritation in the parts and thus tends to aggravate the disease. Care should be taken that the foot is kept in a good position,—that is; that the femur is not rotated either inward or outward. This can be accomplished by attaching the weight to a wide board and then binding the foot to it so that it cannot be turned one way or the other, or in any other way that the ingenuity of the surgeon may suggest. In the mean time the child's general health should be attended to, plenty of nutritious food given, and such other means adopted as seem required.

It has been asserted that this confinement to the bed is a great injury to children,—that they grow thin, and that we are encouraging rather than limiting the disease in the bone. I think, however, that the picture is a misleading one. It is astonishing how well children bear this confinement,—how fat and healthy they get, even in surroundings far from

healthy, if they are spared the debilitating effects of pain. There is no tonic better than quiet sleep and freedom from pain, and, on the other hand, there is nothing that depresses the health of a child so quickly as sleeplessness and suffering. If absolute fixation of the joint can be obtained and at the same time the patient can have the advantage of fresh air and sunshine, the latter will certainly be no small advantage; but we must be sure that the fixation is obtained, for in the early stage this is of paramount importance.

During the second and third stages of the disease the same plan of treatment is applicable: the tendency to deformity should be met by changing the line of traction. If abscesses are detected, they should be treated by the method mentioned in the section on their management.

Some advocate the correction of any malposition of the limb by immediate restitution under an anæsthetic. This method is mentioned only in order that a protest may be entered against the use of any such barbarous means. The deformity is due not to position, but to muscular contraction: in order to rectify the malposition the muscles on one side must be stretched by forcible extension, and to accomplish this the head of the bone must act as the fulcrum and the limb as the powerful lever. By thus crowding the head into the acetabulum injury cannot but be done to the diseased parts, and nothing but an aggravation of the inflammation can be expected. When the disease has been of long duration and when much force has been used, fracture of the femur, or dislocation of the head of the bone on the dorsum of the ilium, has taken place.

Since greater attention has been paid to joint-disease, mechanical ingenuity has been directed towards devising an instrument for the treatment of hip-disease by which perfect fixation could be obtained and at the same time the patient be permitted to go about. The adoption of extension by means of adhesive plaster and weight and pulley pointed out a way by which this end could be accomplished, and the hip-splint, as at present used in this country, is the outcome of the labors of orthopædic surgeons in this direction. To Dr. T. H. Davis is generally given the credit of first conceiving the idea of the present form of hip-splint. Dr. L. H. Sayre soon followed, if he was not contemporary with Dr. Davis. But to Dr. C. F. Taylor is due great credit for his labor in developing the mechanical treatment of hip-joint disease, and the instruments now in most general use are all modifications of the original instrument devised by him. The fundamental principle of a hip-splint is a hip-band encircling two-thirds of the circumference of the pelvis, to which is attached a steel bar extending down below the foot on the diseased side. The splint used by Dr. Taylor is the type of all such instruments. Its form and construction are as follows:

“It consists of a hollow rod of steel (*A*) reaching from the ankle to the hip, with the foot-piece (*B*) working at the lower end and lengthened and shortened by a key which works in a rack on the outside of the lower bar. The upper end is solid and very strong, and is fastened to the pelvis-

band by a bolt (*D*). *E* is the pelvis-band, which is made of steel strong enough to support the patient's weight without yielding in the least, and is about two-thirds of the circumference of the pelvis measured over the trochanter major. It terminates in a strap behind, which is fastened into a buckle in front; at *g, g, g, g*, buckles are placed, to which perineal straps

are fastened made of flannel covered with kid or some non-irritating material, terminating in pieces of webbing strong enough to hold in the buckles." It will be noticed that the buckles for the perineal straps are close to-

FIG. 10.

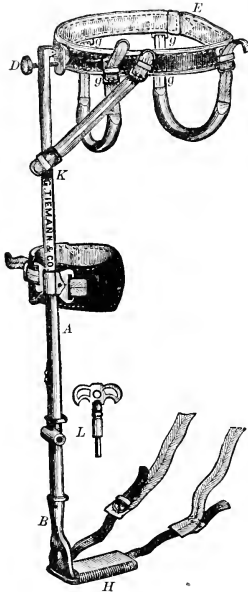

Taylor's splint.

FIG. 11.

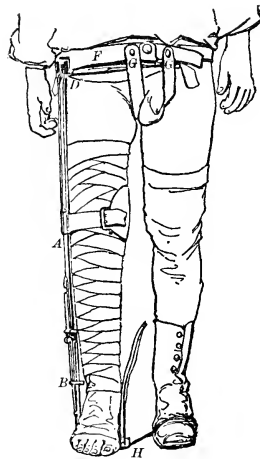

Taylor's splint applied.

gether in front, so that pressure shall not come upon the adductor tendons, and far apart behind, so that the bands may pass under the tuber ischii. *F* is a leather pad to steady and support the knee, and is furnished at *G* with a movable cross-piece. The foot-piece (*H*), the shaft of which extends up into the hollow bar (*A*), passes under the foot. At the lower end of this foot-piece a ridge is left on its anterior and its posterior edge, so as to form a depression through which can pass the strap fastened to the ends of the extension plaster, and thus protect the strap from cutting out. There is also a buckle placed upon the bar at *K*, and another at the hip-band, a strap passing from one to the other, so as to keep the band level.

The following is the method of applying the splint. Two broad bands of strong adhesive plaster—made for this purpose, and obtainable of any druggist—long enough to extend from the upper portion of the thigh down to the ankle, and having a buckle securely fastened at the lower end of each piece, are prepared. A bandage is then applied over the plaster, so as to

hold it securely, a few turns being made under the buckles at the ankle, so as to protect the skin in this locality.

The brace is applied by first placing the patient upon his back, great care being taken that the pelvis is level, so that the limb shall be in its deformed position; the hip-band is then slipped around the pelvis and fastened, the perineal bands are drawn tightly, and the leather straps under the foot are buckled to the adhesive plaster. The pelvic band should embrace the pelvis below the anterior superior spinous process of the ilium. When all is adjusted, while the patient is on his back, the key, *L*, is turned to the right and the instrument elongated, when the whole leg will be gently but strongly drawn downward. Care should be taken that the splint is applied in the line of the deformed

FIG. 12.

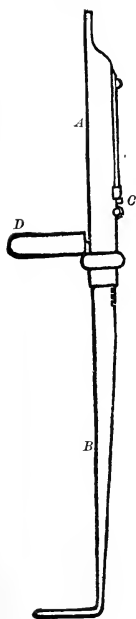

Front view.

FIG. 13.

Side view.  
Judson's splint.

FIG. 14.

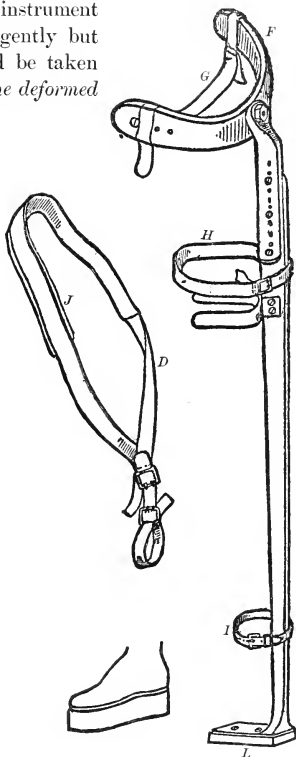

limb, not at right angles to the transverse axis of the pelvis, for if the force be applied in the latter direction intra-articular pressure will be produced. The line of extension must be gradually changed until all deformity has been overcome. In order to accomplish this an inclined plane is used, only the splint is substituted for the weight and pulley. Fig. 11 represents the splint applied.



Dr. A. B. Judson has modified Dr. Taylor's instrument in some particulars, his object being to diminish the weight of the splint, while retaining its strength. Figs. 12, 13, and 14 represent this instrument. It consists of a hip-band, and an upright extending from the pelvis to the foot (Fig. 12). The upright consists of two pieces (*A* and *B*). *A* is a square long box large enough to permit the lower portion *B* to slide within it and be moved up and down by a key working in slots on the outer portion of the foot-piece at *C*. The lower portion for a child twelve years of age should be one inch wide for that part entering the box, and from this point should gradually slope down to the foot-piece to half an inch or an inch. Attached to the upper portion (*A*) and sliding in a collar around it is a U-shaped bar of steel (*D*): when this is applied it is placed a short distance above the knee, and further fortified by a strap *H* (Fig. 14), to prevent any anterior, posterior, or lateral movement of the limb. There is also another strap just above the ankle (*I*, Fig. 14), further to limit motion; the thickness of the lower bar is about a quarter of an inch, except near the foot-piece, where it is considerably under, as in Fig. 13. The upper portion of the upright (*A*) is fastened to the hip-band (*F*, Fig. 14) by a bolt whose head is sunk; the long upright arm can be placed at any angle of flexion and then fixed by tightening the nut. The bolt passes through a square hole at *M* (Fig. 13). Fig. 14 is a lateral view of the splint. Two straps are secured to the foot-piece *L*, one on each side, to which the extension-plasters are fastened by buckles. A shoulder-strap (*J*) is provided, which passes over the opposite shoulder and is fastened to the upright bar by a loop, thus carrying a part of the weight of the instrument. A perineal band (*G*) is fastened to the hip-band and passes under the tuber ischii. The shoe upon the foot of the sound limb is raised from half an inch to two inches. Dr. Judson's instrument is perhaps a little too tight in its lower segment, and the use of two perineal straps and a longer hip-band would add to the stability of the instrument.

Dr. H. L. Taylor<sup>1</sup> describes an instrument for correcting adduction. "It consists in the shank and side-plate of the long hip-splint ending above in a properly-shaped spreading carrying a perineal strap adjusted to the groin opposite to the adducted thigh. The apparatus is applied to the inside of the adducted limb and fastened by a strap and buckles to adhesive plaster attached to the leg, as in cases of hip-disease. Screwing out the apparatus by the key produces a direct and well-nigh irresistible abducting force, which is easily borne and perfectly under control." Fig. 15 represents such an apparatus. Some splints are provided with an abduction-screw.

There are many modifications of the long splint for the treatment of hip-joint disease made to meet the views of different surgeons, but they do not change the general principle as found in the braces known as Taylor's, Sayre's, or Judson's. Dr. Taylor claims for his splint—and

<sup>1</sup> New York Medical Journal, 1887, No. 19.

the same claim is made for all splints constructed upon this principle—that it absolutely fixes the joint, that it protects it from all jar and prevents muscular spasm, and that it permits the patient to go about without any injury to the articulation. He makes the following statements: that locomotion with extension after all reflex contractions have been overcome is useful, and, moreover, is a positive advantage, and “a necessity to a perfect articular hygiene,” and that “an organ in a certain degree of progressive inflammation presents conditions essentially different from the same organ in the same relative degree of inflammation in the retrogressive stage. Extension can cover, as a means of treatment, but a certain portion of time through which an inflammation of the hip-joint must pass in its several stages. There are positive indications for extension, and there are positive limitations for its use. The limitations are reached at the point when the muscles have become soft and compressible and interstitial movements have become completely retrogressive.”<sup>1</sup>

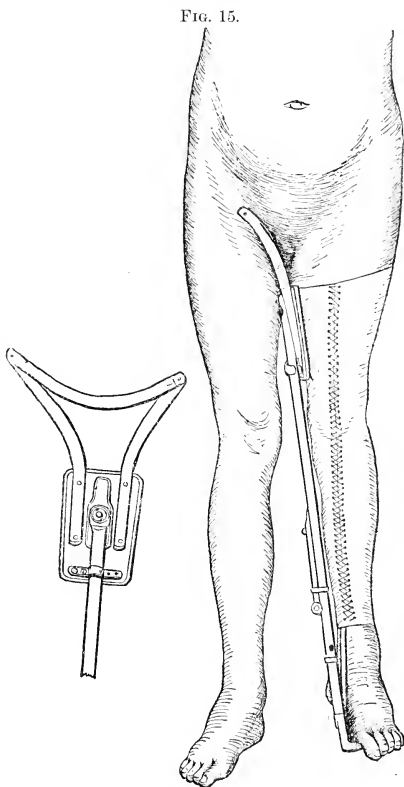

Taylor's abduction splint.

We think that these views are too radical, and that the premises are not exactly correct. In the first place, perfect *continuous* extension cannot be kept up, from the very nature of the tissues we have to do with: adhesive plaster will stretch, and the skin will relax, no matter how firmly the splint may have been applied, or how much extending force has been put on by means of the key and ratchet. After the patient has been about for some time the straps at the foot will be found loose; in other words, the extending force has diminished, and continuous extension has not been obtained. Even when the child is in bed with the splint on, the same condition will

<sup>1</sup> Boston Medical and Surgical Journal, March 6, 1879, p. 318.

be found in time,—namely, that the maximum extension cannot be maintained.

Motion in an inflamed joint, or even in one where the reparative process is well advanced, can do nothing but harm, and is too dangerous a procedure to be thought of. The reliable signs of a cure in hip-joint disease are the disappearance of muscular spasm and the return of the muscles to a soft condition; and until these have occurred the joint must be looked upon as diseased, and absolute rest is a necessity.

In regard to the amount of fixation obtained by this form of splint, the experiments of Dr. R. W. Lovett, of Boston, are interesting.<sup>1</sup> In demonstrating the amount of motion that takes place at the hip-joint in the healthy limb, it was found that with a Taylor splint with one perineal band applied with an extending force of three and a half pounds the thigh moved on the pelvis through an arc of thirty-five degrees in walking; with eight pounds, which could be endured only for a few minutes, there was movement over an arc of fifteen degrees. With two perineal bands better fixation was obtained, though this was not because of the amount of traction, but seemed to be due to the rigid band holding the pelvis and the long leg-shaft holding the leg. Dr. Lovett's deductions from the above are as follows: "That traction in itself furnishes very incomplete fixation, and cannot be regarded as in itself a means of fixing a diseased hip-joint in the treatment of hip-disease; and that a Taylor hip-splint with a rigid pelvic band and two perineal straps furnishes much more complete fixation to the joint than the newer form of the splint with only one perineal strap."

On the other hand, with a diseased joint the tendency is towards fixation on account of the disease itself. In a child with much hip-trouble there will often be found no motion at the articulation, the thigh and the pelvis moving together, or, if there is any motion, it is towards further flexion. The action of an extension-splint passing below the foot and applied in the usual way during locomotion would be to prevent any jarring of the joint by transferring the weight from the foot to the perineum, and by extension to control muscular spasm, and in such a case a movable joint between the pelvic band and the leg-piece is of no use, except to adjust the instrument in the line of the deformed limb (flexion). It would appear, then, that the action of the hip-splint is mainly to prevent excessive joint-pressure, that muscular rigidity has much to do with preventing motion in the joint, and that the splint acts more as a splint than as an extension-apparatus.

That the hip-splint if carefully applied and watched does act so as to relax the rigid muscles is a fact demonstrated by every-day experience; but that it so acts by reason of the amount of extending force exerted by lengthening the brace is doubtful. The amount of extension represented in pounds that a child can bear is not great enough to antagonize the muscles. Dr. Lovett places the amount of power that a child can endure

<sup>1</sup> New York Medical Journal, February 9, 1889, p. 148.

at less than eight pounds, but a hip-splint cannot be made to keep up its maximum power unless it is elongated every hour or so, and this is seldom done. Continuous extension does relieve muscular spasm. What, then, is the therapeutic action of the hip-splint? It would seem (1st) to protect the joint from jars, (2d) to aid in fixing the joint, and (3d), by fixing the joint and by some traction, to prevent muscular spasm.

Dr. Thomas, of Liverpool, has devised a splint which is almost universally used in England, which aims to obtain better fixation of the joint. For a child ten years of age the splint is constructed and applied in the following manner. The patient stands upon the sound limb, and rests his diseased limb upon a block or book in order to bring the spine straight. Take a flat piece of malleable iron three-fourths of an inch by three-sixteenths, long enough to extend from the lower angle of the shoulder-blade in a perpendicular line downward over the lumbar region, across the pelvis slightly externally but close to the posterior superior spinous process of the ilium and the prominence of the buttocks, along the course of the sciatic nerve to a point slightly internal to the centre of the calf of the leg. The iron must be moulded to this track, to avoid excoriations. The iron is moulded to the limb in its deformed position. Next measure around the chest a little below the axilla, deducting sufficient to allow the band when bent to be placed easily in position, and have a

piece of hoop iron half an inch wide, half an inch thick, and long enough when fitted to the chest to encompass three-fourths of its circumference; this is to be riveted on the upright, at one-third of its length from the end next to the diseased side. Fig. 16, *A*, shows the ring moulded to the outline of the trunk. It is important to give the upper crescent an oval shape, to assist in preventing the instrument from rotating from its position behind the body. Another strap of iron, three-fourths of an inch by one-eighth and in length two-thirds of the circumference of the thigh, is fastened to the upright at a position from one to two inches below the fold of the buttock, as at *B*; then another piece of metal of like strength, equal to one-half the circumference of the leg at the calf, is firmly riveted to the upright at *C*. The instrument should be well padded. The form of the apparatus can be easily changed with hooks. If it should slip around in either direction, a change can be made in the shape of the crescents, and, as the limb gradually assumes a straighter position, the curve in the upright can be changed. The splint is completed by providing a strap with a buckle to secure the chest-piece. After the splint is applied the limb is bound to it with bandages. Figs. 17 and 18 show it in use. A patten about two and a half or three inches high is applied for the shoe of the sound limb.



Thomas's splint is based upon a different principle from that known as the American. It depends upon absolute fixation of the thigh on the

as the American. It depends upon absolute fixation of the thigh on the

pelvis and thus securing to the hip-joint perfect rest. But it is a fixation-splint, and in this respect it is an improvement upon the form of splint extending only from the pelvis. Locomotion is not so easy with this splint as with the other. In some respects the principle of Thomas's splint is better than that of the Taylor form,

FIG. 17.

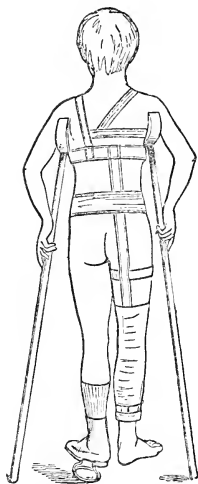

Thomas's splint (back view).

FIG. 18.

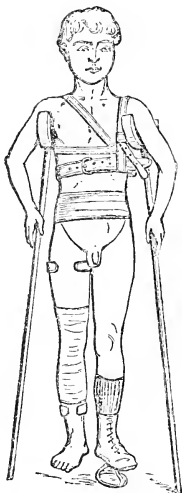

Thomas's splint (front view).

FIG. 19.



Dr. Lovett's splint.

in that there can be no motion at the hip-joint; on the other hand, the American plan affords some extension, while fixation is not so perfect. The former has not the slightest influence in preventing, in the third stage, the head, or what remains of it, from being crowded into the upper portion of the acetabulum, while the latter may do so.

Theoretically, a splint combining perfect fixation and perfect extension would meet all objections. Dr. Lovett has acted upon this plan, and has devised an apparatus (Fig. 19) which combines these two points. It is for the left leg. "The chest-piece *A B* is made to open by a hinge at the back, and when closed in place is buckled across the chest. *C* is an arm for the perineal band running in the same place as the perineal arm of the Taylor splint. *D* and *E* are the regulation thigh- and calf-pieces of the original Thomas splint. From the outer end of *E* the foot-piece runs down below the foot, and ends in a ratchet-and-key arrangement for producing extension, in use in the Taylor splint. The splint is applied, the perineal band adjusted, and the traction-bar tightened last of all."

Whether hip-joint disease is treated by extension in bed or by some

form of hip-splint, it is a mistake to suppose that as soon as the apparatus or extension is applied all anxiety may be dismissed, and that as long as extension is kept up or the splint used the patient is under appropriate treatment. It is a rule that patients who are kept the most quiet do the best, and that frequent inspection and readjustment of the splint are necessary. Light and sunshine are great therapeutic agents, but when they are obtained at the expense of increased pain and other symptoms of progressive disease it is a question whether we are not doing our patient more harm than good. I do not wish to be misunderstood. If you can keep your patient out of doors in the sunshine and let him have the benefit of good air, it is an incalculable advantage; but if the necessary exercise in obtaining this causes motion in the joint, is there not great risk that more harm than good will be done? Probably the best method of treatment of the early stage of hip-joint disease is to put the patient in bed, apply extension by means of a weight and pulley, and secure absolute rest to the joint by means of a long splint. In the early stage of tubercular osteitis anything that increases irritation and consequently congestion of the parts about the joint favors extension of the trouble and prevents healthy action supplanting the morbid process. Taylor keeps his patients in bed with the splint on for weeks; but continuous extension by means of the weight and pulley fulfils the indications better than a splint. Unless there are contra-indications, such as loss of appetite and failure of the general health, it is better to keep the child in bed for a long time. He grows fat, his appetite keeps good, and he is perfectly contented; and as long as this lasts it is safer than going about with a splint. Later a hip-splint may be used, but with the understanding that the patient should be kept as quiet as possible, the child going about in a carriage. If at any time an exacerbation comes on, the patient should be kept in bed and at absolute rest with a long splint applied, and should not be allowed to get up until all symptoms have disappeared. The advent of an exacerbation means an extension of the disease, and calls for greater rest to the joint. If the child has been up and about, less exercise should be insisted upon. If he has been treated by rest in bed, it is an indication that the disease is progressing notwithstanding our care.

In the second and third stages of hip-joint disease the use of a hip-splint is the best, for the disease has now advanced to the articulation and the joint has become disorganized. If, however, the child is first seen when the disease is at its second or its third stage, treatment by weight and pulley and a long splint is best for some months, and later the application of a hip-splint.

The treatment of hip-disease among the better class and that of the same disease among those in the lower walks of life are different, although the indications are the same. Among the former every suggestion can be carried out, and the child is well fed and well guarded against any injury to the articulation; while among the latter we have to contend against

unhealthy surroundings, improper food, want of proper attention, and often ignorance. With this class rest in bed is not to be thought of, and the application of a splint, the use of a high shoe upon the sound limb, and keeping the child out of doors in pleasant weather, is the best that we can do. It is among the children of the poor that we see the disease so frequently running to total destruction of the joint, while among the wealthy we often see the disease checked in its earlier stage. The treatment of hip-disease is summed up in always securing rest to the joint, and in carrying it out the surgeon must adopt those means that, in his judgment, will best fulfil this indication.

In those unfortunate children in whom both joints have become affected, sometimes the disease of the second joint does not appear until it is well advanced in the first, but sometimes both articulations are almost simultaneously affected. In 1878 there was under my care a child five years of age who died early in the course of the disease from uremia. On post-mortem examination the right hip-joint was found to contain pus; the ligamentum teres was softened, allowing the head of the bone to be dislocated upward and backward. The floor of the acetabulum was diseased over a space about the size of a nickel five-cent piece around the insertion of the ligamentum teres, and was partly necrotic. The cartilage upon the head of the femur was of a yellowish color, and at the point of insertion of the ligamentum teres was diseased. The capsule on its inner surface was thickened and velvety. There was no pus in the left hip-joint; the ligamentum was perfectly healthy. The cartilage upon the head of the femur was white, glistening, and apparently healthy; the acetabulum showed no evidence of disease. There was found a carious spot about the size of a split pea, but of irregular shape, on the upper surface of the head, at a point just below the line of the epiphysial cartilage; the cartilage at this point was destroyed over a small extent. On making a longitudinal section through the head of the femur, that of the right side was perfectly normal; in the left there was a point, corresponding to the carious spot, where there had been a circumscribed osteitis extending inward and upward from the carious point to a spot just behind the epiphysial cartilage. There were other similar but smaller points of the same nature scattered throughout the head.<sup>1</sup>

In this case there was disease about both articulations, and, so far as could be judged, the tubercular deposit occurred in both bones at nearly the same date. In other cases the disease in the first joint may have advanced to total destruction of the articulation before trouble begins in the other.

In some cases of double hip-joint disease there is seen a peculiar deformity known as "cross-legged" or "scissor-leg" deformity. Figs. 20 and 21 represent a case which came under my observation some years ago.<sup>2</sup>

---

<sup>1</sup> Medical Record, November 11, 1879.

<sup>2</sup> *Ibid.*, 1882, vol. xxii. p. 8.

Other cases have been reported.<sup>1</sup> It consists of extension, strong adduction, and rotation outward of both limbs. There are two explanations of this deformity: 1st. There

being disease of one hip-joint, the limb on that side is rotated outward and adducted, in order to bring about parallelism of both lower extremities, the pelvis upon the diseased side being raised. Now the other joint becomes diseased, being adducted and rotated outward, and, the pelvis tending to assume a horizontal position, a crossing of the limbs becomes a necessity. 2d. The right limb being rotated outward and held in this position, the knee-joint cannot be used, and is practically ankylosed, so far

as locomotion is concerned; this, with contraction of the adductors, throws the limb beyond and to the opposite side of the median line of the body; a similar condition of the left limb, together with the necessity to keep the balance, would cause the peculiar condition and gait. If one strongly rotates outward and adducts both limbs, he must walk cross-legged. But all cases of double hip-joint disease do not show this deformity.

The treatment of double hip-disease is double extension, either with weight and pulley or with a double splint. If total destruction of the joint or joints occur, care must be taken that ankylosis does not take place at an angle which will render the limbs useless. In case, however, this should happen, a subtrochanteric osteotomy should be performed and the deformity corrected.

**Treatment of Abscess.**—It is safe to say that in at least one-half of the cases of hip-joint disease beginning in the bone, abscesses at one time or another present themselves; and their proper management becomes a serious question. Upon this subject there is great difference of opinion,—more than in regard to similar conditions about other articulations. The rules already laid down in regard to the general management of abscesses should be carried out,—namely, as soon as discovered they should be evacuated by a free incision, and the parts disinfected, drained, and dressed antiseptically.

FIG. 20.

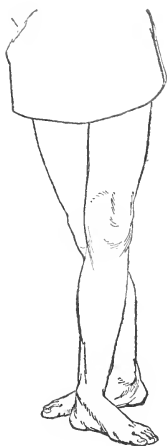

FIG. 21.



Cross-legged deformity. (Poore.)

<sup>1</sup> Lucas, Transactions of the Clinical Society of London, 1881, vol. xiv. p. 20; Tyson *ibid.*, p. 186.



*Intra-Pelvic Abscesses.*—From their position, their danger to important parts, and the liability of the pelvic bones to become extensively diseased, drainage through the joint should be afforded as soon as intra-pelvic abscesses are discovered. Their presence calls for excision of the joint, and a free perforation of the floor of the acetabulum is imperatively demanded, for in no other way can the abscess be reached and drainage provided for.

*Results.*—The results of mechanical treatment of hip-joint disease differ much. The social position of the patient, as stated before, has great influence upon the result; yet even among the better classes some cases do badly, notwithstanding the attention given the patient. In those cases in which the disease begins in the synovial membrane a cure is effected sooner than in those beginning in the bone. Bone-tuberculosis is, as a rule, slow in its development, and if it pursues a course towards a cure the changes do not take place rapidly. Another element is the duration of the disease and its stage before the child has been placed under treatment. Those cases in which a cure has been effected within six months belong to the synovial variety. In the first stage of articular osteitis, recovery with normal motion is probable; if the disease has advanced to the second stage, a cure with limited motion is possible; but after it has advanced well into the second stage, or has entered the third stage, a joint with any useful motion is an impossibility, and a cure with a stiff joint with the limb in good position is the best result. After the cartilages have been destroyed the articular cavity is obliterated by granulations springing from the denuded surface of the bones, and fibrous or bony ankylosis must result. In these cases there may be some slight movement upon passive motion, but active motion is not attained. In the latter cases if there is any flexion it will increase, because in using the limb the tendency is towards further bending of the thigh upon the pelvis. These are the cases where upon leaving off the splint, although the limb is in a good position, after a time flexion will be found to have increased, as well as lameness in walking. The position in which a limb is ankylosed is not a matter of indifference. If the flexion is great and there is much adduction, the walk will be bad and often a crutch will be required to aid in going about, although the actual shortening may be slight. If the thigh is fixed in a straight line with the long axis of the body, locomotion will be easy, but the patient cannot sit down with any comfort or put on his shoes. Therefore a position which is a compromise between these is the most useful. It has been found that an angle of one hundred and thirty or one hundred and thirty-five degrees with the long axis of the body will give the patient the best use of the limb; all adduction must be removed, but a slight amount of abduction is an advantage, because it causes depression of the pelvis upon the diseased side and compensates for the shortening which is due to actual loss of bone in the joint or arrest of growth in the whole limb secondary to the disease.

The question is often asked whether by early passive motion a movable articulation cannot be obtained, and whether long rest of the joint does not

favor ankylosis. Motion in a diseased joint always increases the amount of inflammation, consequently the amount of exudation; rest, upon the other hand, tends to limit disease, and therefore the amount of fibrous tissue. There is no idea more erroneous than that because a joint is kept at rest it will become stiff. No joint ever became ankylosed from merely being at rest; on the contrary, rest is often the only way to prevent ankylosis. Stiffness of an articulation the result of inflammation is due to muscular contraction, or to the products of inflammatory exudation either within or without the joint: therefore the best way is to limit or arrest inflammation, and this is allayed only by keeping the parts quiet.

The deformity after hip-joint disease is often marked, and the question often arises whether an attempt to correct it by forcible movement under ether is permissible. It is a rule to which there should be no exception, that any forcible manipulation of a joint that has been the seat of tubercular disease should never be thought of. The danger of rekindling the disease is great, many joints have been destroyed by such attempts, and often a fatal termination has followed; while, on the other hand, it never does any good. In cases where ankylosis has taken place in an unfavorable position, a subtrochanteric osteotomy is the best and the only justifiable means to correct the deformity. In those cases in which there is limited motion yet the limb is in a vicious position, extension as in the early stage of hip-joint disease may be tried, and then a splint used; but in my experience the result has been disappointing, the deformity after a time returning, the difficulty being that the muscles shorten again and the bands of adhesion resume their former condition.

Statistics as to the final result of the treatment of hip-joint disease by mechanical means vary. Dr. Taylor<sup>1</sup> makes the following statement: "Leaving out of consideration all cases whose histories subsequently to their treatment are unknown or in doubt, I find that there remain ninety-four private cases of hip-joint disease which were under personal observation and continuous treatment from the time they applied until they died or were cured, and whose present condition is now or was very recently a matter of personal knowledge; for no case whose ultimate fate is not positively known deserves a moment's consideration in any estimate of the probable value of treatment for the hip-joint. Of the ninety-four cases three died,—two of the disease, one was run over and killed. Among them there were twenty-four with suppurating joints and discharging abscesses,—nearly all in that condition when first applying. Of these twenty-four with abscesses, two died, and in five the discharge has not ceased. Deducting these seven, there remain seventeen fully recovered, or seventy per cent. of suppurating cases. Three of the seventeen cases recovered have ankylosis, and fourteen recovered with practicable joints,—the majority with ample, and some with perfect, motion. The ratio of motion to

---

<sup>1</sup> Boston Medical and Surgical Journal, March 6, 1879.

ankylosis in cases recovering after suppuration more or less extensive is as eighty-two to eighteen. In two of these cases still discharging, ankylosis is progressing favorably, and in three there is excellent motion. Except for the slight discharge remaining, these would be among our best cases."

Dr. Taylor's statistics, although very flattering, are almost useless, because no distinction is made between disease beginning in the synovial membrane and disease beginning in the bone, and they prove nothing more than that these cases of inflammation about the hip-joint recovered. It would be interesting to know how many cases during the period in which these ninety-four were under treatment passed from under his charge, with their condition and subsequent history; for it is a well-known fact that many cases pass from under the care of a surgeon because they are not doing well or have become dissatisfied, and these are the cases that make up the unfavorable side of statistics.

From the annual reports of the New York Orthopædic Dispensary and Hospital from 1880 to 1889, there were under treatment thirteen hundred and thirty-eight cases of hip-joint disease; of these one thousand and eighty-two were discharged. Of the latter, three hundred and forty-nine were discharged cured,—thirty-two and one-third per cent.; five hundred and three discharged relieved,—forty-six and one-half per cent.; one hundred and ten discharged for neglect,—ten per cent.; ten discharged incurable,—one per cent.; and one hundred and ten died,—ten per cent. The reports do not state how many of these were suppurating cases, nor the nature of the disease. The treatment followed is strictly mechanical; the patients are as well cared for as possible, the method is the best in the way of personal attention, and the support is all that could be desired. The condition of those discharged "relieved" is not stated, but it is fair to assume that the disease was not checked, and that it went on to a natural cure or proved fatal from constitutional causes. It is also reasonable to suppose that many in this class ceased to attend because the disease was getting worse, and, as is always the case among the lower and middle classes, they did not bring their children back because they were not improving. Granting that thirty-three per cent. of these would have been cured, this would have raised the percentage of those cured to about forty-eight per cent.

Looking at these two sets of statistics, there seems to be an irreconcilable difference between them. Dr. Taylor's patients are drawn from the most favorable class, while the others are from the lower walks of life. The former show much better results than can be obtained in the treatment of tubercular disease of the bones, taking the cases as they are met with in general practice; while the latter compose those only who are from the most unfavorable class. Statistics are always misleading unless it is known just what class of cases are included.

When a splint can be left off, and what are the signs of a cure in hip-disease, are important questions. In the first place, all pain must have long ceased. A return of plumpness in the muscles of the limb is a sign

of no small import. If abscesses have appeared and sinuses formed, their orifices should be depressed and should be drawn inward by an attachment to the bone. Muscular spasms should have ceased, the muscles themselves, if they are not shortened, should be soft, and the joint-movement should be free in those cases in which ankylosis has not taken place. The splint should not be left off at once. Extension may be first dispensed with at night, and the limb gently exercised; then the splint can be left off for a short time each day, so that the muscles may gradually become strong. Finally, after weeks the patient may be permitted to take moderate exercise, care being taken that the limb does not get tired. Dr. Taylor uses a special splint during this period. Notwithstanding our care, relapses will often occur, due either to a new focus of disease or to some injury to the articulation,—a fall or over-exercise. The return of any fixation or flexion in the joint is a very reliable sign that we have to do with a new accession of disease, and that a return to the former treatment is necessary.

#### COMPLICATIONS.

There are few complications in hip-joint disease that deserve notice.

*True dislocation* is rare, yet it is sometimes met with during the first stage or in the beginning of the second, when the ligamentum teres has been destroyed and adduction is present: in these cases the capsule may not be ruptured, as proved by post-mortem examination (p. 1160). What remains of the neck of the bone in advanced stages of the disease may leave the acetabulum and be upon the dorsum of the ilium, and may become ankylosed in this position. Gibney has reported two cases, one in which a true dislocation occurred in the first stage. Marsh also mentions a case in which the head of the bone left the cavity of the acetabulum before any diminution of its size or change in its shape had taken place. In these cases, when it has once occurred it is liable to be again displaced. Marsh thinks that dislocation is more liable to occur in acute synovitis; but in the case mentioned above the post-mortem examination showed the absence of any synovitis. Whenever the accident has happened, the dislocation should be reduced at once under ether, and extension applied so as to prevent its occurrence, the treatment being kept up as though it had not occurred. The accident does not seem to have any influence upon the course of the disease.

*Perforation of the gut or of the bladder by an abscess* is a serious complication. The only case that has come under my observation is the following:

A boy three years of age with disease of the hip-joint came under my care. At the time of admission an abscess had formed and pointed above the joint. He was at the seaside at the time. He had experienced for some time much pain upon any movement of his bowels or in passing water; his bowels were constipated. In November, 1886, he was placed under ether and the abscess opened. The ilium as well as the head of the femur was found to be greatly diseased, the acetabulum was perforated, and a large collection of pus was present in the pelvic cavity. The head and neck of the bone were removed, and the opening through the acetabulum was enlarged so as to afford drainage to the pelvic abscess. The wound healed well, except a good-sized sinus which formed a direct com-

munication with the pelvis. In December feces of good shape and consistency were found on the dressing after each movement of the bowels; at this time the discharge of pus was slight. In January the child was again placed under ether for examination. There was found a large cavity formed apparently by the abscess forcing the pelvic fascia inward; its boundaries could not be made out with the finger, but the bladder could be distinctly felt. No fecal accumulation could be discovered, nor on washing out the cavity could any be found in the overflow. Apparently no water passed into the rectum, nor from the rectum into the abscess-cavity, but water passed freely into the bladder and out through the urethra. The patient was returned to bed and serious symptoms were looked for; but there was nothing beyond a temporary elevation of temperature to 103° F. for a few days; there was no cystitis, and from that date no feces were discovered on the dressings, but urine passed from the wound and saturated the dressing. The patient still passed some water through his urethra, but the greater portion through the wound. In February an opening was made into the bladder, the same as for the median operation for stone, in order to drain the bladder and thus prevent any accumulation of urine, in the hope that the opening into that viscus would close; a rubber tube was inserted. Gradually it ceased to flow from the wound in the hip, and by October the sinus in the hip had closed, also the perineal opening. Since then the child has been well.

Marsh, Wright, and others have mentioned the presence of feces on the dressings.

**Amyloid Degeneration.**—Of all complications of hip-joint disease this is one of the most serious. It is usually to be suspected when suppuration has been profuse and the patient has a white, waxy look, and it is one of the most common causes of a fatal termination. But profuse and long-continued suppuration alone is not invariably followed by this change in the liver and other abdominal organs. We often see patients die from exhaustion from profuse suppuration, and on post-mortem examination not a trace of amyloid deposit can be found; while, on the other hand, an enlarged liver, albumen in the urine, and other symptoms may be detected soon after suppuration has commenced. So far as my observation has extended, it would seem that a marked hereditary tubercular diathesis is a predisposing cause; at least the most marked and early cases of this affection have been met with in the offspring of tubercular parents. These children usually die from dropsy and uremia. When once this change has set in, the only chance of delaying its course is to limit suppuration. That it is not necessarily a fatal complication is proved by a case under my care in 1876. The boy had extensive disease of the hip; there were numerous sinuses about the joint, which constantly discharged unhealthy pus. The disease had existed for four years. The thigh was flexed upon the abdomen and strongly adducted. The liver and spleen were much enlarged; the urine was albuminous; the boy was pale and waxy-looking. In the spring of 1876 the joint was excised; the head was found loose in the acetabulum, and the upper portion of the shaft much diseased. From the date of the operation the boy began to improve, and in December was discharged, with a high shoe and a shortening of four inches, due partly to the amount of bone removed, but chiefly to arrest of growth in the limb. In 1881 he was re-examined; no symptoms of any enlargement of the liver could be found,

and the urine was free from albumen. He was earning his living as a plumber. In 1888 I heard of him, and his health was then good.

On the other hand, we not infrequently see patients who have recovered from hip-disease die from the effects of amyloid degeneration which began during the suppurative stage of the joint-trouble. Mr. Barwell mentions the case of a girl seven years of age with amyloid disease, where excision had failed to limit the suppuration. The liver filled the whole right side of the abdomen; the limb was amputated, and the wound healed without suppuration; the liver and spleen very rapidly diminished in size; the albuminuria ceased. Eight years later the girl was fat and healthy. It would seem that the only chance for a patient with amyloid disease is to stop the formation of pus as soon as possible.

**General tuberculosis** is not a common complication, but tubercular meningitis is. The latter may come during any period of the joint-affection. Marsh states that it is more common in the suppurative stage. But the few cases that have fallen under my observation have been in the early stage of the joint-affection, before pus had been detected. The disease presents various modes in its development, sometimes giving but slight warning until convulsions appear, or it may follow the course so frequently seen in tubercular disease of the brain. It is, unfortunately, a fatal disease, and all that can be done is to relieve the pain and control the convulsions.

**Hemorrhage** has been met with during the stage of suppuration, from perforation of vessels of varying size.

Growers mentions a neuritis from contiguity of tissues, and Donaldson<sup>1</sup> reports a case of peripheral neuritis and epilepsy occurring in a patient affected with suppurative disease of the hip-joint. But the connection between the neuritis and epilepsy and the hip-joint disease is questionable.

#### OPERATION UPON THE HIP-JOINT.

There is much difference of opinion among surgeons in regard to operating upon the hip-joint when diseased. Some state that in a large experience they have never found a case so desperate that excision, in their judgment, was called for, while others advocate an operation as soon as an abscess is discovered. That both are honest in their opinions there can be no doubt, yet it seems hard to reconcile these two statements. Perhaps a partial explanation may be found in the class of cases falling under the observation of different surgeons. Those whose practice is entirely among the wealthy do not so often see the disease in its worse forms as those engaged in hospital practice. Statistics of twenty years ago should not be quoted, as improved ways of treatment and operation have placed both methods upon entirely different grounds. The danger to life in operating upon large joints has been so much diminished that a fatal termination from the operation itself is the exception. Large joints are opened, their con-

<sup>1</sup> British Medical Journal, 1888, vol. i. p. 1003.

tents scraped out, or the ends of the bones removed, with scarcely any elevation of temperature following, and but little shock. On the other hand, the methods of treatment by extension or splints have so much improved that as many cases do not run to total destruction of the joint as in former years, and the resort to radical measures is not so often called for. Besides, the pathology of articular inflammation is better understood. For these reasons the question of excision rests upon different grounds from those upon which it rested formerly.

A clear distinction should be made between cases occurring in private practice, among those who realize the danger of articular inflammation and are able and willing to carry out to its fullest extent the instructions of the surgeon, and those who belong to the lower walks of life, who often have neither the intelligence nor the time to carry out the necessary treatment, and who live in crowded dwellings contaminated with foul air and cannot procure the proper food so absolutely necessary to combat successfully the constitutional vices to which the disease is due. Among those who draw their experience from these two classes some difference of opinion might be expected; yet I think that the difference is too great, and that there is a middle ground upon which both should meet. There are some cases of hip-joint disease that do well—that is, so far as life is concerned—no matter what treatment is adopted, even when the expectant plan is followed, which is really no local treatment; other cases do badly under the best of management; some cases pursue an almost malignant course, when the only chance to save life is in the total removal of the limb.

The result of excision of the hip-joint renders the patient more or less a cripple for life: the cases that recover with slight shortening are too few to hold out any expectation that they will ever form the rule. So far as the limb is concerned, the best result after an excision will not compare in usefulness to a limb ankylosed at a favorable angle. The question of excision, then, rests upon other grounds than comparative usefulness. We must admit that, notwithstanding the success of the operation, the patient has suffered a serious mutilation. Excision should therefore be reserved for those cases in which no means less severe will accomplish the purpose. Reference to statistics will not afford much aid; they are unsatisfactory and misleading and can be made to prove almost anything. Each case must be judged by itself.

In considering the necessity for excision, the causes of a fatal termination must be taken into account. These are exhaustion, tuberculosis, and amyloid degeneration; and really the question turns upon preventing these diseases.

The mere presence of an abscess is not of itself an indication for excision, for if it is opened and treated antiseptically it may close in a few weeks or months and a good result be eventually obtained. If, however, new collections of pus continue to form, there is every reason to suppose that considerable disease of the bone exists, and in a subject of marked tubercular

antecedents it is good practice to open the joint freely and remove the head and neck, curette thoroughly the parts, and wash out the wound with an antiseptic solution, for these are the cases in which amyloid degeneration is prone to show itself, and our only hope for the child is in limiting suppuration by removing the cause. This should not be put off too long: our endeavor must be to anticipate the advent of lardaceous disease and operate before the patient's health has become seriously impaired. The presence of an enlarged liver and of albumen in the urine is an indication rather than a contra-indication for operating.

In cases of profuse or long-continued suppuration in those not of marked tubercular parentage, an operation is called for. A sequestrum in the joint-cavity may be the sole cause of the persistence of suppuration. All cases in which suppuration continues for any length of time, even if it be only from a small sinus, will be benefited by an exploratory operation and scraping the fistulous tract, or the removal of some diseased bone may hasten a cure. On theoretical grounds the presence of tubercular foci calls for excision. I say upon theoretical grounds, because almost all cases of disease of the hip-joint are tubercular in their nature. Yet it is evident that the rule in practice is not and should not be followed. If the presence of tubercle in the bone is as serious as some have claimed, few cases of hip-disease should recover. The question of the duration of the disease is not alone to be considered. If the affection goes on from bad to worse, if we have reason to believe that we have to do with a case in which the tubercular process is advancing, one in which constitutional symptoms are marked and rapid deterioration of health ensues, the indications are to relieve the patient of the source of the trouble as soon as possible.

The presence of an intra-pelvic abscess in connection with hip-disease calls for a removal of the head and neck of the femur and a free opening through the articulation, in order to afford drainage to the pelvic abscess, no matter what the condition of the joint may be.

In cases where the epiphyses have been cast off and the remains of the neck are dislocated, the joint should be opened and the loose epiphyses removed; or where, from the history of the case, such a condition is suspected and there is a sinus, the joint should be opened. I have met with quite a number of this latter class, where, on operation, a sequestrum or loose epiphysis was found.

In children of bad family history, where there has been tubercular disease in both parents' families, or where several brothers or sisters have died from tubercular disease, the question of excision should be considered early, as these are the cases in which a fatal termination is to be looked for. In the last stage of the disease, when the thigh is riddled with sinuses, the bones extensively involved, and the general health seriously affected, excision may be called for in order to make the last days of the little sufferer more comfortable. In private practice excision of the hip is rarely



demanded; yet there is no question that a more frequent resort to it would be a gain.

Where an acute condition has supervened on a more chronic state of suppuration, where purulent discharge becomes abundant, and where marked fever and increased weakness supervene, excision is proper.

A persistent elevation of temperature calls for an explorative operation, and may demand a removal of the head and neck of the femur.

Scraping out the joint with a Volkmann's spoon is often followed by good results: only diseased and softened tissue should be removed.

In the early stage of osteitis Macnamara advocates exposing the bone over the great trochanter and with a large drill or a small trephine making a free opening through the trochanter into the neck and, as he believes, into the head of the femur. In one case a small quantity of pus was at once evacuated. The limb was fixed on a splint and the wound dressed antiseptically. There was no elevation of temperature, and from that time the patient lost all pain. The wound over the trochanter healed within a fortnight. Two months later the joint was practically ankylosed, but otherwise the child had good use of the limb. Six years later the limb was found perfectly sound, the patient healthy and able to stand upon the limb all day. Mr. Macnamara's idea is "that by opening the soft vascular tissue in which tubercle is forming, and then establishing efficient drainage, a more healthy action may be established in the parts."<sup>1</sup> Wright<sup>2</sup> mentions having tried this operation in a few cases, and speaks well of it.

Noble Smith<sup>3</sup> has resorted to this method, and states that he has "met with most satisfactory results from piercing the trochanter with one-tenth of an inch and one-eighth of an inch drills, two openings made at about an inch and a half apart being followed by rapid cessation of pain (upon slight movements), heat, and swelling." His method is as follows. A puncture is made with a scalpel over the trochanter to the bone, the periosteum is divided for one-third or one-half inch, the bone is drilled to the depth of half an inch or more, and the parts are syringed out with a solution of carbolic acid, one to forty. I have tried this operation in three cases, and can speak well of it. It certainly stops the spasmodic contractions of the muscles and relieves pain at once. But sufficient time has not elapsed since the operation to allow of our speaking definitely as to its influence on the course of the disease.

In opening an abscess it is always well to examine the joint: this is already disorganized, and no harm can come from such a procedure; besides, it affords a ready way for drainage of the articular cavity.

The views of operating surgeons differ in regard to the advantage of excision of the hip-joint. Bryant states that if dead bone can be made out to exist in suppurating hip-disease there can be no question about the

<sup>1</sup> Diseases of Bones and Joints, 3d ed., p. 427.

<sup>2</sup> Hip-Disease in Children, p. 109.

<sup>3</sup> Lancet, 1889, vol. i. p. 322.

propriety—nay, the necessity—of its removal, and, as it is generally in or about the head and neck of the femur, it seems tolerably certain that the best practice lies in excision of the head. An operation undertaken upon the hip-joint under these circumstances is scarcely any more severe than an operation for necrosed bone, and in all probability is not more dangerous.

Clowell<sup>1</sup> says “that in hospital cases it should be performed as soon as there is distinct grating in the joint, accompanied by pains, profuse suppuration, or failure of health, and that it should be performed without loss of time as soon as these conditions are recognized.”

Wright (*op. cit.*) considers that in hospital cases nothing short of excision can prevent the ultimate progress of the disease and, too often, the gradual exhaustion of the patient from pain and discharge; also that “a knee-joint in which there is suppuration, with caseous masses of bone in the upper end of the tibia or the condyles of the femur, is not looked upon as a condition to be treated by rest, good position, and external applications, but one urgently demanding incision, excision, or amputation.”

Barker,<sup>2</sup> in his excellent article on tubercular joint-disease and its treatment by operation, concludes as follows: “I venture to think it would be a wholesome rule that, in cases where general tubercular disease does not contra-indicate it, the infected tissue of the joint should be thoroughly removed as soon as it is suspected that caseation is advancing in it; further, I believe that, until some such rule is adopted as a general guide, improvement in the results of operations on tubercular joints will be slow.”

Macnamara<sup>3</sup> says, “If in spite of careful treatment, including efficient drainage and rest, the patient continues to grow worse, grating being detected in the joint, and there is no evidence of lardaceous disease, my advice is, without further delay excise the head and neck of the bone, together with the great trochanter of the femur. . . . It leads to favorable results, provided the operation is not too long delayed.”

On the other hand, Mr. Holmes is not an advocate of the operation except in desperate cases. Dr. C. F. Taylor has never met with a case in which it seemed to him called for.

Marsh, although not an advocate of early excision, considers the operation to be called for in the following class of cases. (1) When the whole head of the femur, or what remains of it, has become necrosed and detached, so as to form a loose sequestrum. (2) When, in spite of three or four months' complete rest and free drainage, suppuration remains copious and the general health is giving way; provided, however, that there is no evidence of extensive disease of either the femur or the pelvis and no wide burrowing of matter in the limb. (3) When along with continued suppuration there is so much displacement of the upper end of the femur that

<sup>1</sup> British Medical Journal, 1882, vol. ii. p. 366.

<sup>2</sup> *Ibid.*, 1888, vol. i. p. 1264.

<sup>3</sup> *Op. cit.*, p. 112.

the limb cannot be brought into a good position without an operation. Any symptom of amyloid degeneration is, in Marsh's opinion, an additional ground for excision.<sup>1</sup>

At the New York Orthopædic Dispensary and Hospital, excision is not advised, or at least is not performed.

**Operation.**—There is no classical operation for excision of the hip-joint. There are many ways of reaching the articulation. A curved incision

FIG. 22.

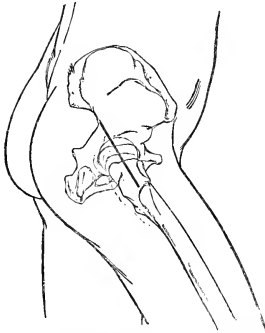

Straight incision over the trochanter in excision of the hip-joint. (MacCormac.)

from the tip around the posterior border of the trochanter affords easy access from behind to the joint and allows of good drainage. Many adopt a straight incision on the outer side, cutting at once down to the bone (Fig. 22). "The patient is placed on the sound side, and the limb flexed; an incision is then made in the long axis of the femur over the outer side of the trochanter major; it should run a little behind the middle, and correspond with a line directed towards the posterior superior spine of the ilium; two-thirds, or nearly, of the length of the wound, which is about four and a half inches long, lies over the ilium above the trochanter, and the remaining third upon the trochanter and femur."<sup>2</sup> But in whatever way the capsule

is reached, after being exposed it is opened and the bone examined. If the incision is made directly over the trochanter, the tissues over it are to be raised with a periosteal elevator, so that the head and neck of the femur are easily reached. The old method of turning the end of the bone out through the wound in order more easily to divide it is to be condemned: it disturbs the soft parts more than there is any necessity for. After exposing well the head and neck, the diseased parts may be readily divided with an osteotome, and the end of the bone removed from the acetabulum with a pair of strong forceps. The muscles inserted in the digital fossa, if the trochanter is to be removed, should be separated from the bone.

Having taken away the head and neck, the acetabular portion of the articulation should be examined. Any portion of bone that is loose should be removed; but I have never seen any benefit from gouging away inflamed bone in the pelvis, unless it was circumscribed. If the floor of the acetabulum is perforated, it is well to see that there is a free opening into the pelvis, so that there may be good drainage from that cavity. The upper end of the femur is next to be examined, and if there are any points of disease they should be everted, or if they are extensive more bone should

<sup>1</sup> Diseases of the Joints.

<sup>2</sup> MacCormac, Surgical Operations, part ii. p. 355.

be taken away. As a rule, in advanced cases the neck and upper part of the femur will be found diseased, and a section just above the trochanter minor will be necessary. With a pair of curved scissors all infiltrated tissue and the remains of the capsule should be removed, in order that the wound may be left as healthy as possible. The periosteum should be separated from the shaft as far down as the point of section, and carefully preserved. Some insist that the trochanter major should always be removed, as its presence is apt to close up the cavity of the acetabulum and prevent drainage of that cavity. If there is extensive disease of the pelvis, it is better to remove it; but if the disease is not marked, and the infiltrated tissues about the joint have been freely removed, there should not be much, if any, purulent discharge. Active hemorrhage is slight: it is not often that it is necessary to apply a ligature, but there is always considerable oozing during the operation, and a free discharge of blood and blood-serum for the twenty-four or forty-eight hours after.

In some cases the shaft of the femur will be found to be thinned, of a dark color, the periosteum easily detached, and the cavity of the bone filled with a dark yellowish-red material. In such cases further section may be made, but only to find the same diseased state. If this condition is left, a cure is very remote: some cases have made a good recovery, but they are the exception and not the rule; the end of the bone will crumble away, granulation protrudes from the cut end, sinuses about the hip will continue, and, later, amyloid degeneration of the abdominal viscera will be found.

The best course to pursue in this complication is either to amputate the limb or to clean out the central cavity of the femur. I have frequently performed the latter operation, and always with benefit. In order that the whole medullary cavity may be cleaned out, the shaft of the femur just above the external condyle is exposed and a button of bone about half an inch in diameter removed; a long probe to which is attached a piece of silk ligature, and longer than the length of bone from the point of trephining to the point of section above, is passed through the whole length of the medullary cavity of the bone; to the latter a long strip of iodoform gauze is securely fastened and drawn through by means of the ligature silk, and the cavity thoroughly cleaned out. The medullary cavity is then washed out by allowing a stream of mercuric solution (one in one thousand) to run through until it is well cleaned. A short rubber drainage-tube is then inserted into the opening in the bone, the edges of the incision are brought together with catgut, except where the drainage-tube comes out, and over this is placed a small piece of iodoform gauze and then an antiseptic dressing. Nothing more is required. The drainage-tube may be removed in a few days, and the wound soon closes. The cavity in the bone should not be syringed out, but should be left alone.

In the first case in which I adopted this plan, on the third day I attempted to flush out the medullary cavity, on the supposition that further

cleansing was necessary. The cavity was found to be filled with dense coagulation, perfectly sweet. Since then I have left the parts alone. In one case some osteitis followed; it was detected three weeks after the operation; the shaft of the femur became enlarged, but no further ill effects followed.

The management of the pelvic bones depends upon the amount of disease: if they are extensively involved, not much good, as a rule, is to be expected from scraping and gouging. So far as my personal experience goes, this disease, if at all marked, is a serious complication, and, although the femoral portion of the operation may do well, the pelvis when carious does not take on a reparative action, no matter how freely the diseased portion may have been removed. Cases where the process is more localized, and where sequestra are found, do better. Hancock and Erichsen, it is true, have removed large portions of the ilium with good result, but the bone was necrotic, not carious. I have removed diseased bone about the rim of the acetabulum, when confined to a small spot, with benefit. If there are any abscesses they should be opened, and their walls thoroughly curetted, disinfected, and drained, if possible not through the joint. During the operation the parts should be frequently flushed out with an antiseptic solution. After cleaning out the wound it should be thoroughly washed with mercuric solution (one in one thousand), and the edges of the incision brought together with wire sutures passed very deep except opposite the acetabulum, and here there should be left a good-sized space, much larger than will take the drainage-tube; the latter should be of good size and pass to the bottom of the cavity; around this should be packed iodoform gauze, and over this an ample dressing of mercuric gauze, the whole being secured by a figure-of-eight bandage.

The reason why it is an advantage to leave so much space about the drainage-tube is that after a time the rubber will get infected and have to be removed, and then the drainage will be insufficient. Again, it is an advantage to have a firm cicatrix above the decapitated shaft, so as to hold it firmly when the limb is used; and, besides, by keeping the wound stuffed it heals well from the bottom and affords a better chance for any necrotic tissue that may have been left to escape. It is possible, in this way, to keep the wound aseptic; at least, my cases have done much better since this plan was adopted than they did when the wounds were more generally closed.

After applying the dressing a long splint extending from the axilla to the ankle is lightly bandaged on, and as soon as the patient has been put in bed extension is applied, the plaster for which is put on before the patient is etherized. A long stocking put on over the bandage affords protection from the blood, etc., during the operation.

There is usually some shock, but it soon passes off. The use of an opiate is generally required the first night, but after this is not called for. The dressings, as a rule, have to be changed the next day, being filled with

bloody serum. The immediate effect of the operation is a marked improvement in the condition of the patient: there is seldom any fever if the wound has not become infected, and there is freedom from pain. The long splint should be retained, and the parts kept as quiet as possible, in order to favor healing of the wound. The patient should not be allowed to sit up.

In some cases after an excision there may be exuberant granulations which show a tendency to break down about the drainage-tube, or there may exist sinuses showing the same character of granulations protruding from their mouths. These are of a tubercular nature, and call for their removal by an exploratory operation, to see if there are any tubercular foci that have been overlooked, and the free use of a Volkmann's spoon. If they are not removed they will further infect the parts, and the disease will not be checked.

Until within the last few years access to the joint has always been obtained by a lateral incision over or near the trochanter major. Lücke, Schede, and Hüter some time ago advocated an incision on the outer side of the crural nerve. Barker<sup>1</sup> has used this method of reaching the articulation, and speaks well of it. The operation is performed in the following manner.

The incision commences on the front of the thigh, half an inch below the anterior superior spinous process of the ilium, and runs downward and a little inward for three inches. As the knife sinks into the limb it passes between the tensor vaginæ femoris and the glutei muscles on the outside of the sartorius and the rectus, until it reaches the neck of the femur. This incision does not divide any muscular fibres, nor any vessels or nerves of the slightest importance. The head and neck are then divided *in situ* and removed with a strong pair of forceps. Fig. 23 shows the line of incision. If there is not found room enough, the incision can be enlarged, care being taken that the Y-shaped ligament is left as far as practicable, the whole operation being done with as little violence to the soft parts as possible. The diseased tissues are then removed with a pair of curved scissors and a Volkmann's spoon.

After removing the head and neck Mr. Barker<sup>2</sup> keeps the wound continually flushed with hot water (105° to 110° F.) which has been previously sterilized and placed in a three-gallon can; this has three taps below, to each of which six or eight feet of india-rubber tubing are attached, and to the latter an instrument consisting of a gouge shaped like a Volkmann's spoon; its handle and shank are hollow, and attached to the end of the handle is the rubber tube.

FIG. 23.



Anterior incision for excision of hip-joint. (MacCormac.)

<sup>1</sup> British Medical Journal, 1880, vol. i. p. 16.  
VOL. III.—76

<sup>2</sup> Ibid., 1889, vol. i. p. 23.

The instrument is used to flush out the diseased cavity with hot water while the softened bone and tuberculized synovial tissue are being gouged and scraped away. The whole cavity is in this way cleaned, and the diseased tissue, being immediately removed, has no chance to infect the sound tissues; besides, the hot water checks hemorrhage.

After removing all the diseased structures the cavity is dried with carbolized sponges, one or two being left in until all the sutures are in position. These, which are of carbolized gut, should dip deeply and be placed close together. Just before they are tied the sponges are removed, and with them the last trace of moisture. The wound is filled with iodoform emulsion, and the sutures are tied, as much of the emulsion being squeezed out at the last moment as will come away. In most cases no drainage-tube is used. An antiseptic dressing is then applied and firmly held in place by a figure-of-eight bandage.

Mr. Barker claims for this method that primary union is obtained throughout the whole wound. He reports some cases treated after this manner, and up to date there had been no return of disease, with joints slightly movable. The whole operation is based upon the theory that if complete removal of tubercular tissues from the hip-joint is accomplished the resulting wound ought in many instances to heal by first intention throughout. In one case I tried the anterior incision, and found that the joint was easily exposed and plenty of room afforded. The hot water was not used, and, unfortunately, a point in the wound became infected and a tubercular abscess formed.

The result of excision of the hip-joint in general hospital practice has not been so good as that of other joints. It is very difficult to obtain reliable statistics. Patients are sent out before the real result is known, and many operators fail to state just what is meant by cure.

The following are the results in my own hospital practice. Of forty-nine cases, in nine the patients were between three and four years old, in six between four and five, in six between five and six, in eight between six and seven, in six between seven and eight, in six between eight and nine, in four between nine and ten, in two between ten and eleven, one patient was between twelve and thirteen, and one was fourteen years old. Of these, four are still in the hospital, one of whom is well; twenty were discharged cured; eleven were discharged relieved or unimproved; fourteen died. Of those discharged, three are known to be cured, and eight have died. In regard to the terms "cured" and "relieved," by "cured" is meant that the wound is entirely healed, with no sinus and no pain upon motion; by "relieved," that the wound itself has healed, but that one or more sinuses are present, no matter how useful the limb may be. Of those who died while under treatment, eight died from amyloid disease, two from meningitis, one from tuberculosis, one from peritonitis, and two from exhaustion. Of those discharged relieved, one has never been heard from, six died from amyloid disease, and one died from peritonitis. These figures show that twenty-three

cases, or fifty per cent., were cured, and that twenty-one cases, or forty-seven per cent., died.

No patient has died from the effects, immediate or remote, of the operation, while, on the other hand, the general condition of those who subsequently died improved for a time: all pain was absent, many of them were able to be about, and were gaining flesh, and suppuration diminished. The cause of a fatal termination was not local, but constitutional; the operation had nothing to do with it. They died not from but in spite of the operation. The date of the fatal termination in these cases varied from a few months to several years; in some cases the patients after the wounds had entirely healed were going about without support. In two cases it will be noted that death was due to peritonitis secondary to amyloid degeneration. The condition of the bones in all the cases operated upon showed that the disease had advanced to the third stage and often well into it, loose bone being in many instances found in the joint. In a few cases the operation consisted only in removing a detached epiphysis.

In regard to the function of the limb: in some cases it was excellent,—lapse of time had not increased the amount of shortening; but in the majority of cases the limb did not grow so fast as the sound one, and a higher shoe had in time to be used. In most cases after excision of the hip, unless there is a very strong cicatrix the upper end of the femur rides up on to the pelvis at every step, due to stretching of the bands which unite the shaft to the ilium; this increases the shortening, and the joint lacks stability. After excision the patient should use a hip-splint for at least a year after getting up, so that these bands may not be called upon to sustain any weight until they have become dense and strong. One of the patients is now twenty-seven years of age, is perfectly healthy, and has good use of his limb; another is twenty-six years of age, is a plumber by trade, and is able to do a good day's work, although he has seven inches shortening, the greater part due to arrest of growth. The following table shows the amount of shortening and its increase in ten cases which have been examined since discharge:

1	patient at time of discharge had	1 inch;	8 years after had	2½ inches.
1	“	“	“	“ 1½ inches; 18 months after had 1¾ inches.
1	“	“	“	“ 1½ inches; 6 years after had 2½ inches.
1	“	“	“	“ ¾ inch; 18 months after had ¾ inch.
1	“	“	“	“ 1½ inches; 1 year after had 1½ inches.
1	“	“	“	“ 1 inch; 5 years after had 1½ inches.
1	“	“	“	“ 1 inch; 2 years after had 1½ inches.
1	“	“	“	“ 1 inch; 18 months after had 1 inch.
1	“	“	“	“ ¾ inch; 3 years after had 1½ inches.
1	“	“	“	“ 4 inches; 14 years after had 7 inches.

Of fourteen cases in which the amount of shortening at the time of discharge was recorded, it was slight in two, three-fourths of an inch in two, one inch in three, one and a quarter inches in two, one and a half inches in four, and four inches in one.



In a table given by Wright (*op. cit.*), of two thousand four hundred and sixty-one cases of excision, there were one thousand five hundred and sixty-six cures and eight hundred and forty-one deaths; but these statistics are not reliable; they were collected from all sources. A great many of these cases must have been discharged with open sinuses, and many of them eventually died.

The time of operation has a great influence upon the mortality and upon the proportion of successful cases. Those who excise early—as soon as abscess forms—have much better results and fewer fatal cases; but there is no doubt that many of these patients could have been cured without resorting to so radical a method; on the other hand, those who do not excise until the patient's general health has failed and there is extensive disease, operate too late, and consequently have a greater mortality. There is a middle course between these two extremes, which is the safer to follow.

Turning to the valuable reports of a committee of the Clinical Society of London found in the fourteenth volume of the Transactions of the society, and based upon statistics derived from three hundred and eighty-four cases treated without excision, of which two hundred and sixty were suppurating and one hundred and twenty-four non-suppurating cases, the results are as follows. Of two hundred and sixty cases with suppuration, thirty and two-fifths per cent. died from causes connected with the disease, of which nine and one-fifth per cent. died from tubercular affection. The average duration of treatment was two and a half years; the average shortening in thirty-three cases, one inch and three-fifths. The movements were free, limited, or *nil* in the proportion of five, four and a half, and three. Of one hundred and twenty-four cases without suppuration, the total mortality was ten and one-half per cent., and that from tuberculosis was seven per cent. The average duration of treatment in cases that recovered was less than three years.

In Wright's personal statistics, of one hundred cases eighty-five recovered and fifteen died; but on examining his table it is found in the last report that there still existed one or more sinuses in sixty-four cases, so that, strictly speaking, these should not have been reported as cured.

The results of excision are such that it must at present be put down as an operation of necessity, and should be advocated only in those cases where from the family history of the patient or the condition of the parts a cure by mechanical means seems remote. I have an impression, which cannot be proved by statistics, that those who have had tubercular joint-disease are not long-lived,—that they generally die before they reach very far in adult life; and this is strengthened by the fact that the offspring of tubercular parents are of feeble resisting power and die early in life.

## DISEASES OF THE KNEE-JOINT.

“Next to the hip-joint the knee is most liable to inflammatory affections in childhood. It is the largest joint in the body, alike in regard to the size of the articular ends of the bones, the extent of its synovial membrane, and the area of its cavity. Any affection of the joint, therefore, especially any acute inflammation, is necessarily on a large scale, and is liable to be attended with a corresponding amount of constitutional disturbance. Owing to the shape of the articular ends of the two bones of which it is mainly formed, and the way in which the shallow facets of the tibia are constructed to slide upon the condyles of the femur, displacement very readily occurs when the joint is in the position of semiflexion, which it at once assumes as a position of greater ease when it is attacked by disease. In this attitude the tibia is in contact with the femur over only a very limited surface, and is easily drawn backward towards the popliteal space by the hamstring muscles. . . . All muscles surrounding the knee are, more than those surrounding any other joint, the hip excepted, liable to be the seat of continuous and severe reflex contractions whenever inflammatory disease is present. The joint is formed by the opposed ends of two long and powerful levers; it is situated in the middle of a bulky limb which contains an elaborate system of powerful muscles, which connect with the trunk by means of a joint that allows motion in every direction; the ends of the femur and tibia which meet at the knee are those in which growth in length of the lower extremity is mainly effected, and any extensive interference with them is liable to be followed by arrested development of the limb.”<sup>1</sup>

The knee-joint may be the seat of acute, subacute, or chronic disease, which may involve the bones or the synovial membrane.

## SYNOVITIS.

Acute synovitis is not uncommon among children: the exposed situation of the joint and its almost subcutaneous position make it very liable to injury. The cause of acute synovitis may be a sprain, a wrench, a blow, or any injury; it may follow exposure to cold. The seriousness of the case will depend not only upon the amount of violence, but also upon the constitutional predisposition of the child. It is not often that a simple synovitis becomes purulent. If, however, there is a tubercular diathesis, the injury may be the starting-point of tubercular disease of the articulation. Almost every one who has had much to do with joint-disease among children has seen cases in which an acute synovitis coming on after an injury has not responded to treatment as is usually the case, but has passed into a subacute condition, and after a time the joint will

---

<sup>1</sup> Marsh, op. cit.

convey to the fingers a boggy feel, or the bones develop tenderness in certain localities, and a tubercular disease of the joint be found to exist. Again, an acute synovitis not properly treated may degenerate into a chronic, and the joint finally become stiff. The prognosis in a case of acute synovitis in a healthy child is good in regard both to the integrity of the limb and to life.

**Symptoms.**—From the superficial position of the knee, any changes in its shape are readily detected, and therefore the signs of an acute synovitis are easily recognized. They are stiffness, swelling, heat, and pain. Swelling comes on immediately with the access of the inflammation and follows the outline of the synovial cavity; the patella is raised from its normal position in contact with the condyles by the effusion. All the normal depressions about the joint are obliterated, and the articulation has a puffed-out appearance; the skin, unless the inflammation is very acute, is not changed in color, but the joint feels hotter than the sound one. There is pain upon motion. If the inflammation is more acute, the skin may become red or even œdematous, the leg becomes flexed upon the thigh, that being the most comfortable position for it to assume, and there is an increase of pain, with considerable constitutional disturbance. Pain, however, varies much: in some cases while the joint is at rest it is only slight, while in others the patient is kept awake by its severity. As a rule, the more acute the disease the greater the pain and the higher the temperature. If the affection is very acute, there may be some muscular atrophy, and this may give the impression that the capsule is more distended than it really is. The contents of the joint in acute synovitis will show only a turbid albuminoid fluid, more limpid than the natural secretion of the joint: its turbidity varies; in the more acute cases it may be opaline; in cases after severe injury it may be, and often is, stained with blood.

**Treatment.**—The cardinal point in the treatment of synovitis of the knee, as of all other joints, is absolute rest to the articulation, and this must be rigidly carried out. The child should be confined to the bed, and the whole limb fixed by means of a splint extending from above the hip to below the foot, so as to prevent all motion in the hip, knee, and ankle; besides, there should be a posterior splint applied to prevent any flexion at the knee. Should there be much flexion at the knee, it is better to give ether and place the limb in a straight position; this can be done without any danger, for as soon as the muscles are relaxed this can be accomplished without the use of any force, or the same end may be attained by extension applied to the leg. If the joint is left flexed, a posterior dislocation may take place.

After securing absolute rest, cold should be applied to the joint, by means either of an ice-bag with several layers of flannel interposed between the bag and the joint, or of cold evaporating lotion; lead-and-opium wash is often useful. Some writers advocate the use of leeches, but they are apt to frighten children, and, besides, the disease can be controlled as well with-

out their use. If the pain is marked, opium should be given and its effects carefully watched. The child will experience most comfort from placing the whole limb upon a pillow, support being given to the thigh and leg. When the tension is very great and the pain severe, relief may be obtained by puncturing the joint and removing some of the effusion; this should be done with great care and by means of an aseptic needle. If there is much spasm of muscle, extension should be used, the force being applied in the long axis of the leg. Treated in this way the inflammation will be subdued; but the patient should not be allowed to use the limb for some time, a posterior splint being kept on.

Subacute or chronic synovitis sometimes persists after an acute attack; when this exists a rubber bandage may be applied, and the joint kept at rest. Blisters have also been advocated, and often do good. But our main reliance must be upon rest and fixation, or a Thomas splint may be applied and the patient be allowed to go about; for a description of this splint reference is made to another portion of this article.

Sometimes an acute synovitis will become purulent,—that is, effusion will gradually assume a purulent character without much increase in the constitutional symptoms. When this occurs the joint may be washed out with a mercuric solution through two canulas, one placed on either side of the joint, and the solution allowed to run through until it comes out clear.

SUPPURATIVE SYNOVITIS may follow a blow or other injury, but is most generally met with after wounds of the articulation from which the joint has become infected; it may be caused by the spread of inflammation from surrounding parts, as an abscess bursting into the synovial cavity.

The symptoms, both general and local, of a purulent synovitis are marked. It is often ushered in by a marked chill, high temperature, and notable constitutional disturbances. Swelling and pain in the joint are marked, so that the least jar of the bed or room will aggravate the sufferings. The skin soon becomes cedematous and red, and often the seat of phlegmonous inflammation. If there is an external wound, it will look angry and pus will flow from it. If there is any doubt as to the nature of the effusion, a hypodermic needle will settle the question.

If pus is found in the joint, only one course is to be pursued: the articular cavity must be freely opened—under antiseptic precautions—on both sides, and the cavity washed out with mercuric solution, one in two thousand or one in fifteen hundred, and finally with one in one thousand. There are in the joint three spaces which should be thoroughly drained,—the suberural pouch above the patella, the space under the ligamentum patellæ, and the posterior aspect of the joint. Into these short rubber drainage-tubes should be passed, so as to be just within the synovial cavity, which should then have a final flushing through these drainage-tubes. The incision should then be closed except where the tubes pass out, the part surrounded with an ample antiseptic dressing, and the limb thoroughly

immobilized. The dressings will probably have to be changed daily and the cavity flushed out.

Under this treatment the temperature will go down, the pain cease, and, as a rule, the articulation be saved. But action must be prompt: every hour of delay after the advent of the disease adds to the danger to life and limb.

Mr. Treves<sup>1</sup> adopted a plan of continuous flushing of the joint with cold water rendered antiseptic with various substances; the irrigation was done through two tubes, one on each side of the joint, into one of which a continuous flow of water was sent to be discharged through the other. This was kept up day and night for one month. The patient "had a very high grade of inflammation in and about the joint; the whole limb was œdematous." The effect of the irrigation was very marked. At once the patient was free from all pain, the tongue, which had been dry, became moist, and he recovered with a normal degree of motion.

In purulent synovitis of a not very intense type, good results have been obtained by puncturing the joint with two good-sized trocars, one on each side, and washing out the joint by allowing a stream of mercuric solution (one in two thousand) to flow through the joint. In one case I tried this method, with very satisfactory result. Carbolic-acid solutions, except when very weak, have not acted well in my hands, as they are apt to coagulate the fibrin and cause thickening of the capsule.

When there is an extensive wound into the joint, the articulation may still be saved by careful antiseptic treatment; but if inflammation has gone on to destruction of the joint, the most favorable result is an ankylosed limb. In these acute inflammations one of the great dangers is that the tibia may become dislocated backward, and to prevent this the limb should be kept in a straight position. Of course the strength of the patient must be kept up by tonics, plenty of food, stimulants, and opium to relieve pain. If these means fail to limit the inflammation, nothing will save the patient's life but amputation.

#### TUBERCULAR DISEASE OF THE KNEE-JOINT.

The synovial membrane is more frequently affected with tubercular disease than any other articulation. Its exciting cause may be an injury of some kind, or it may be impossible to connect it with any traumatism; it may develop after an acute synovitis, or may come on so quietly that its exact advent cannot be determined; but, whatever its exciting cause, there is always a tubercular diathesis back of it, and without this strumous disease never occurs.

Symptoms are often insidious: it may come on spontaneously, with stiffness as an early symptom; there may be an absence of pain, yet the patient will limp from inability to extend the leg fully upon the thigh,—and this is

<sup>1</sup> British Medical Journal, 1888, vol. ii. p. 8.

an important indication of disease. With this stiffness there is always swelling, for to this latter is the stiffness due. The disease may begin with obscure pains and a feeling of weakness in the joint, with which there is stiffness, and a slight limp may continue for some time without any other symptom to attract attention, although a careful examination of the joint will at this time detect some thickening of the synovial membrane and slight swelling of the joint-tissues.

In other cases the swelling will come on without the least pain either in walking or upon pressure. The swelling in these cases is peculiar and characteristic: at first it may have the form of the synovial sac, and in this stage fluctuation in some cases may be detected; soon, however, it changes to one of a soft semi-solid nature, conveying to the touch a boggy feel, as though the joint were filled with a gelatinous material. Barwell states that in those cases in which there is fluid at first the joint tumefaction may be only temporary, to be soon followed by the characteristic doughy swelling of tubercular disease of the synovial membrane. When the disease pursues its usual course, the swelling first shows itself at the side of the patella and then extends to the whole joint, so that all the normal depressions are obliterated and the limb at the knee-joint assumes a rounded or fusiform contour. The skin has a white appearance. Barwell states that the more intense this whiteness the more marked is the tubercular infiltration. The amount of swelling may be determined by comparing the measurements around the two joints.

Marked atrophy soon takes place in the muscles of the thigh and leg, making the diseased joint more prominent than the swelling alone would do. Atrophy is an important symptom, no matter how slight it may be. It is generally present within a few weeks of the commencement of the swelling and persists throughout all phases of the disease. In old cases the bones of the thigh and leg seem covered only with skin and fibrous tissue, so profound has been the muscular wasting. In time the atrophy involves the bones, so that they are much smaller than those of the sound limb.

Sooner or later in those cases that do not receive proper treatment, or in which the progress of the disease has not been stayed, the joint becomes completely disorganized; the leg becomes flexed upon the thigh, often to a marked degree; the tibia is liable to undergo displacement in the direction of a rotation outward, and a sliding backward of the head of the bone upon the condyles of the femur, and also a sliding outward. As the disease advances, the joint-cavity becomes filled with a pinkish-gray pulpy mass; the synovial membrane is greatly thickened, the ligaments are softened, the cartilage is eroded, and finally the bones become involved in the disease. Abscesses form in this granulation-tissue within the joint, and the pus slowly perforates the capsule; the skin becomes red and tender, then ulcerates over a small extent of surface, and allows the thin, unhealthy pus to escape. Long before this has taken place every tissue in the joint-structure has become infiltrated with this gelatinous material.

One of the most unfortunate complications is the dislocation of the tibia backward, due in part to the flexion of the leg and to the contraction of the muscles on the posterior aspect of the thigh, and in part to the destruction or softening of the lateral ligaments of the joint. The appearance of the limb after this has taken place changes entirely: the swelling disappears to a certain extent, and the end of the femur stands out over the head of the tibia. This displacement of the tibia may take place with or without the occurrence of abscesses, and the bone may become ankylosed in this position.

Pain at some time in the course of the disease is marked, even if it is absent in the earlier stage. As the cartilage becomes eroded, there occur frequent painful startings of the limb, similar to those in disease of the hip-joint. There may be, however, a dull aching pain, increased at night, besides the acute suffering due to the crowding together of the inflamed tissue by muscular starting.

Maenamara states that local elevation of temperature affords valuable information as a guide to prognosis. He recommends that the thermometer be used twice a day over the joint and the temperature compared with that of the sound limb. If we find a marked and persistent increase of heat over the affected knee, we may feel sure that changes are going on in the joint which, if not sufficient to excite suppuration, border closely on that stage of the disease.

The course of tubercular disease of the synovial membrane is either towards caseation, towards abscess and inflammation of the whole joint, or towards connective-tissue metamorphosis and cure, depending upon the general health and the treatment of the patient.

TUBERCULAR OSTITIS of the ends of the bones forming the knee-joint is frequently met with. It may be confined to the end of the femur or tibia, or there may be foci of disease in both bones. These foci may gradually extend by inflammatory and necrotic changes until they reach the joint, or they may become replaced by connective tissue and the joint escape, or, again, these caseous masses may remain quiet for an indefinite time and finally become active and cause destruction of the joint. I have met with these caseous deposits in the head of the tibia or condyles of the femur, where no indications of their presence could be obtained by inspection of the articular surface. These tubercular deposits are apt to attack both bones.

The starting-point of a tubercular deposit often is an injury, by which the osseous tissue may be bruised, some blood may be extravasated, or some interference with local nutrition may take place, and thus form a congenial nidus for the tubercle-bacillus. But, whatever may have been the cause of the disease, when once established its symptoms, though at first obscure, in time leave us in no doubt as to the nature of the complaint. The early symptoms of tubercular osteitis are often obscure. There may be some pain, especially at night or after exercise; it may be an aching or uncomfortable

feeling on certain movements, coming some time after an injury, for the development of tubercular disease of the bone is often slow. The course followed by the deposit has much to do with the prominence and rapidity with which marked symptoms show themselves, whether the bone is infiltrated with tubercle, slowly undergoes caseous change, or becomes the seat of connective-tissue changes. In the first variety the joint is soon affected; in the second it may not be affected for months; while in the third it may never show any sign of disease.

The pain may be confined to one of the condyles of the femur or to the head of the tibia, depending upon the bone involved; after a time pain in the bone may be more persistent, but with exacerbations. There is often tenderness upon pressure over a certain point; frequently there will be thickening of the periosteum over this point; if the deposit is situated deep, no thickening, or but slight, may be felt. Gradually the lameness increases and the joint becomes flexed. As the abscess approaches the joint-surface the pain and discomfort increase, as a rule, there are painful startings of the limb at night, and the parts about the articulation appear swollen. Gradually the joint itself becomes enlarged, through effusion which does not disappear after rest; this may continue serous until the abscess opens into the joint, or it may become gradually purulent, or the joint may become the seat of tubercular disease independent of the bone-trouble.

I think that the classical description of the opening of a tubercular abscess of the bone into a joint, followed by acute purulent synovitis, is not in all cases in accordance with clinical experience. I have seen joints which have been invaded by tubercular abscess show but little acute trouble; often we find only the characteristic tubercular granulation which starts from a small opening in the cartilage leading to a tubercular deposit in the end of one of the bones, and the disease follows the course of a tubercular synovitis plus an osteitis, although there is every reason to suppose that the osteitis was primary. The explanation of this may possibly be that a small amount of tubercular material alone entered the articulation and the joint is slowly infected with tubercle. In some cases of disease of the knee-joint rapid purulent infection of the articulation certainly takes place, but it is not the rule. Early in the disease marked atrophy of the muscles of the leg and thigh takes place. In some cases of articular osteitis the tubercular abscess will discharge not into the joint, but into the soft parts outside of the capsule. The symptoms of a tubercular abscess approaching the surface are increased local deep-seated swelling, increased tenderness upon pressure, often accompanied by throbbing pain (the latter may be intermittent), later local redness of the skin, and finally an abscess in the soft parts.

The fact that a tubercular abscess has opened outside of the capsule does not prevent it from making a way for itself also into the joint, especially if the first sinus is small. A time comes in almost all unrelieved cases of bone-tuberculosis near the joint when the articulation becomes completely



disorganized, abscesses have formed and opened at different points, the joint is deformed and misshapen, and the patient suffers from the effects of suppuration, long-continued pain, and confinement.

In some cases after the tibia has become dislocated backward, the inflammation will subside, the pain be greatly diminished or entirely cease, and a cure be effected with the limb in a deformed position. This occurrence is more common after non-tubercular epiphysitis than in tuberculosis, yet it has been met with in the latter.

Tubercular disease beginning in the bones about the knee affects the joint secondarily, but the articulation does not escape so often as when the bone-disease is of a non-tubercular nature. The prognosis is, as a rule, good in children of not marked tubercular antecedents. Death from this form of joint-disease is not so common as from similar disease of the hip-joint. With proper treatment many cases do not go on to the formation of abscess, and a cure with some useful motion, even in apparently unpromising cases, is not unusual. After disorganization of the joint a cure with ankylosis is to be expected. My impression is that general tuberculosis is more common with disease of the knee than with that of the hip; at least this has been my experience.

Treatment of tubercular synovitis is absolute rest. If the disease is detected early and absolute rest of the joint obtained, in subjects of fair health a cure may be expected with perfect or slightly-restricted motion.

In order to fix the knee-joint, rest in bed must be insisted upon, with a posterior splint extending from the hip to below the foot, with an upright at a right angle to the leg, so as to prevent all motion at the ankle-joint, or a plaster-of-Paris splint may be applied. Any flexion that may exist must be corrected. It may be done at once under an anæsthetic, or gradually by extension, for, no matter how rigid the joint may be in the earlier stage, as soon as the patient is under an anæsthetic the muscles will relax and the leg can be put in any desired position without the use of the least force. If, however, the muscles on the posterior aspect of the limb have become shortened, and force is used to straighten the leg, there is great danger that the tibia will slip back and a dislocation be produced. If the disease is not very acute, an elastic bandage (rubber) is often of use: the "Empire porous elastic bandage," which consists of an elastic webbing made very loose, is an excellent substitute for the rubber bandage; it does not confine the moisture, and any amount of constriction can be obtained, and it is much more comfortable than the common elastic bandage. The limb should be kept still in the posterior splint and bandaged below the knee.

The use of counter-irritation is well spoken of by many: small fly blisters may be used, or, better still, a Paquelin's cautery applied very lightly while at a white heat. If blisters are used, they should be about one inch square, not kept on too long, and the blebs allowed to dry as soon as possible. If at any time abscesses form, they should be opened at once.

After the more acute symptoms have passed, the use of a Thomas splint

affords excellent protection, and with a high shoe the patient may be allowed to go about. The splint is constructed in the following manner (Fig. 24).<sup>1</sup>

"It consists of an upper iron ring (*A*) three-eighths of an inch in thickness. This is well padded. The ring is nearly oval in shape. From its upper and lower portions two iron rods (*B, B*) pass down below the foot; the oval ring should join the inner stem, forming an angle of fifty-five degrees, which when correctly padded is reduced to forty-five degrees. This arrangement of the splint will be the most comfortable. On the end of the two iron rods is placed a patten. Across the bars is stretched an apron of leather, to support the limb, and in the leather are two slits for the insertion of the bandage. A patten is also worn under the shoe of the sound limb. A strip passes over the shoulder of the sound side and is attached by a buckle anteriorly and posteriorly to the oval ring."<sup>2</sup> This apparatus can be used without the leather back, the knee being secured in a plaster-of-Paris splint or a posterior splint, and a bandage over all. Fig. 25 shows the splint applied.

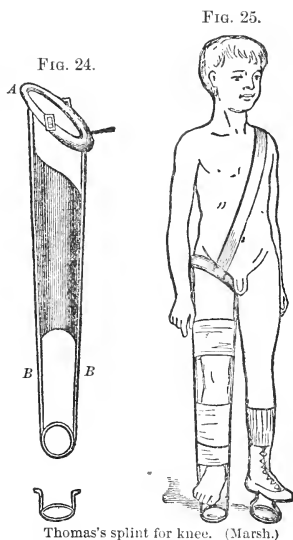

Thomas's splint for knee. (Marsh.)

The splint should be worn for from six months to a year or more, according to the condition of the limb, or until the joint assumes its natural appearance. By this means a posterior dislocation, if not of long duration and if the parts behind the joint have not become too much shortened, may be overcome.

If the joint is much deformed by displacement of the tibia, it may be slowly corrected by gradually changing the angle of the posterior splint. After a dislocation of some duration the muscles in the posterior aspect of the thigh have become shortened and the capsules thickened and shortened, so that even if the tendons are divided the tibia cannot be replaced, on account of the condition of the capsule. Besides, the articular ends of the femur and tibia have become altered in shape, the condyles of the femur being elongated and more conical, and thus overhanging the tibia, so that, if it were possible to bring the articular end of the tibia forward by relaxing the soft parts, the changes in the femur would absolutely prevent the replacement of the tibia being maintained. It is true that splints have

<sup>1</sup> Marsh, p. 440.

<sup>2</sup> Thomas, Diseases of the Hip and Knee and Ankle Joints, p. 98.

been devised which, it is said, will correct this deformity. They are generally constructed with a gutter extending up the thigh and down the leg, with a hinge opposite the joint, and worked with a screw. But the action of these devices is rather to increase than to diminish the amount of deformity.

Of course the patient should be kept in the best possible condition as to his general health: plenty of food, fresh air, and sunshine are to be desired.

The management of tubercular and that of non-tubercular osteitis are the same. The treatment in the first stage is that of osteitis, and there must be absolute rest of the parts. As said before, tubercular osteitis is often insidious in its beginning; the lack of marked symptoms often misleads one as to the true nature of the complaint, and in many cases treatment is not begun until the disease has made considerable advance. A history of occasional pain and lameness, of pain after exercise, or of stiffness in the morning should always excite suspicion as to the existence of an articular osteitis. In a child of tubercular antecedents any injury to the knee-joint should not be looked upon as a slight affair and of little importance, but longer rest and greater protection to the joint should be insisted upon than in a child of perfectly healthy parentage. For tubercular osteitis there is no better or safer treatment than rest in bed with the joint in a good position and a posterior splint applied. The child may be taken out of doors daily in a carriage, and thus have the advantage of air and sunshine. For those in the lower walks of life, who cannot afford the time and care required to carry out this method, the best that can be done is to apply a Thomas splint and a high shoe on the sound limb, and allow the child to go about. Of course a posterior splint should always be applied. This may consist of a plaster-of-Paris splint about the knee. To apply a posterior splint and then allow the child to go about, using the limb, is no treatment at all. If pain increases and symptoms of an abscess in the bone show themselves, there is no better or safer plan than to cut down upon the tender point, apply a trephine, and clean out the abscess-cavity. We may go even further, and say, if a child has received any injury to the articular end of one of the bones, and after rest for weeks there still continues a tender point over the bone, it is good practice and safe to trephine over this point and allow drainage from the bone. There is no danger from this if properly performed, and we certainly are working in the right direction. I have seen good results from this method of treatment.

#### OPERATIONS UPON THE KNEE-JOINT: ARTHRECTOMY AND ARTHROTOMY.

Operations upon the knee have gained much in favor since the indications and methods of operation have been better understood. In children they have been condemned by some surgeons because of the shortening that is liable to occur from arrest of growth if the epiphysial cartilages are interfered with. In very young children some operations are questionable. In

private practice they are very seldom called for. That a radical operation should not be condemned on account of the shortening, I am satisfied from my own experience; that it should always be resorted to as soon as the joint becomes the seat of an abscess, is bad surgery. What, then, are the indications for opening a knee-joint? Suppuration, either acute or chronic, demands an explorative operation, because, if unrelieved, it will most certainly, sooner or later, destroy the articulation, and by early interference a recovery is generally obtained with more or less useful motion. Chronic suppuration must be due to one of three causes: it is the result either of acute inflammation, of tubercular synovitis, or of a tubercular or non-tubercular abscess of the bone which has opened into the joint. In any of these conditions, if we can remove the cause, a much better result can be obtained by surgical interference than by the expectant treatment. In cases of tubercular osteitis where an apparent cure has taken place, there often remain caseous deposits of varying size which are a constant source of danger to the joint: they may at any time break down and gain access to the joint-cavity. These foci are often met with in cases where after an apparent cure we are called upon to operate to correct a deformity, the patient complaining only of vague pains at times in the bone. There is often also some tenderness on pressure over certain points. Upon section in such cases there will be found in the condyles of the femur or head of the tibia a mass or masses of caseous deposit of varying size, which no treatment other than their removal would get rid of. Children with these deposits never have a useful limb; they are always liable to attacks of pain; and, if unrelieved, joint-trouble will at some time break out again.

In all operations upon joints every precaution should be taken to prevent infection, not only from any disease within the articulation, but also from without. The limb as well as the instruments should be washed and disinfected. There are two operations for disease of the knee-joint, having in view the removal of diseased tissue with preservation of the limb,—arthrectomy and arthrotomy.

**Arthrectomy** consists in fully exposing the whole of the interior of the knee-joint, and in completely removing the diseased synovial membrane, ligaments, cartilage, and bone, without any formal removal of the articular extremities. In fact, it is a removal of all diseased structure of a joint, and the removal of diseased structure only.<sup>1</sup> It is applicable to most cases of tubercular synovitis where the bones are not greatly diseased; it is not followed by arrest of growth in the limb, because the epiphysial cartilages are not interfered with. A movable articulation is a possibility, depending upon the extent of disease in the joint, but not a probability.

After rendering the limb bloodless, either by an Esmarch bandage or by raising the limb for a minute or so and then applying a constricting band,—the latter being the better and safer method,—the joint may be

---

<sup>1</sup> Wright, *Lancet*, London, 1888, vol. ii. p. 1086.

opened by one of several methods. A curved incision below the patella, as for excision of the knee-joint; a curved incision above the patella, extending from the head of the tibia upon one side to a corresponding point upon the opposite side; and a transpatellar incision, have been advocated. But whatever method of gaining access to the joint is adopted, it should be ample, and if more room is required other incisions should be made, so that every part of the articulation can be easily reached. Some operators advocate a longitudinal incision in addition above the patella, in order to reach the synovial sac under the crureus muscle.<sup>1</sup> Clatton<sup>2</sup> uses "a long curved incision through the extensor tendon just above the patella and prolonged downward on each side of the line of the articulation. The patella is then reflected downward and the whole joint exposed."

In the transpatellar incision the cut is made directly through the middle of the knee-pan; in young children this bone can be cut through with a knife, but in older the saw must be used. An objection has been raised to this method in young children, that the cartilaginous patella is liable to give trouble after suturing. Tilling uses a U-shaped incision, but goes below the tubercle of the tibia and then detaches the latter with a chisel and raises it in the flap. After completing the operation the bone is replaced and secured with a nail in the old position. He does not seem to have derived any great advantage from this method.

There is still another incision used,—namely, a longitudinal one passing through the centre of the patella and splitting the tendon of the quadriceps. In four cases I have used this incision; in two the joint was opened in order to remove enough bone to cause ankylosis, in one the operation was performed to correct a dislocation of the tibia backward, and one was an arthrectomy for tubercular synovitis. In all these cases ample room was obtained, and all parts of the joint could be easily reached. After cleaning out the joint the divided patella was sutured with strong catgut. The wounds united rapidly, and all the cases did well.

Having gained access to the joint, with a pair of curved scissors and forceps every portion of diseased tissue must be removed,—synovial membrane, ligaments, and the semilunar cartilage. Particular attention must be paid to the synovial sac above the patella. It can be easily removed by dissecting off with the scissors between the capsule and the loose cellular tissue surrounding it and the bone and muscles; no difficulty will be found in accomplishing this, even with an incision below the patella, and it must be much easier with an incision above that bone. In this way the sac can be removed in one mass. Simply scraping the diseased tissues with a spoon will not do this: they are infiltrated, and nothing short of a knife or scissors will accomplish the purpose. Having removed all infected soft parts, all diseased points in the bone must be thoroughly curetted, so that every suspicious tissue is completely removed, even if the infected bone extends up

<sup>1</sup> Wright, *op. cit.*

<sup>2</sup> *Lancet*, 1888, vol. i. p. 762.

to the epiphysial cartilage: all small pits in the cartilage must be gonged out. In cases where the tibia has become dislocated and cannot be brought into position after free tenotomy, sections must be made from the end of the femur and tibia, but for mechanical purposes only.

After all diseased tissue has been removed, the parts are to be thoroughly washed out with a mercuric solution (one in one thousand), care being taken that every crevice in the joint is well flushed. After removing the constricting band, all bleeding points are to be ligated. Very hot water should be used in these cases for flushing out, as it prevents oozing. If an Esmarch bandage has been employed there will be considerable oozing, and this should cease before the limb is finally put up. The incisions are then to be carefully brought together with silver wire or catgut. A very important point to be attended to is the drainage: this must be ample; it is far better to have too much than too little. One tube should be brought through the popliteal space, one on each side of the suberural pouch, and one on each side of the lateral incision. The use of nails or pegs is not required.

The limb should be placed upon a posterior splint and put up in plaster of Paris. Iodoform gauze is placed over the line of incision, and over this an antiseptic dressing. The dressing usually has to be removed the day after the operation, on account of the gauze becoming filled with blood and serum, but the iodoform gauze need not be disturbed. After this, as a rule, there is no necessity for changing the dressing for weeks, or until the drainage-tubes are removed. The best result of an arthrectomy is a stiff joint, and this should be the end in view. A movable articulation is possible, but there is danger that the disease may be rekindled.

Volkman considers that there should be a certain preparation of the joint before the operation,—that all flexion should be overcome by weight and pulley where it has existed and where it is possible to correct it, all abscesses opened and freely spooned, disinfected, and allowed to heal, and all fungoid masses removed from sinuses. He does not use the bloodless method, believing that the condition of the tissue cannot be so well judged of when blanched, and also that the loss of blood is greater after the use of an Esmarch bandage than without one.

The ultimate result of arthrectomy for tubercular disease of the knee-joint is to a certain extent in doubt, as the operation has not been in practice long enough to form a basis for statistics. Out of fifty-five cases thirty-nine were reported as cured, and the remainder as well at the date of the last report. In five cases a subsequent excision had to be performed, and in one other case it would be necessary. Of the five patients on whom the operation of excision was performed, three subsequently had the limb amputated and recovered. Besides these, in three other cases amputation was performed, four patients died,—three from tuberculosis, one in convulsions,—and three cases were incomplete.

According to Wright (*op. cit.*), in those that do well the common factors seem to be (1) absence or small amount of suppuration, (2) superficial or at

least not wide-spread bone-disease, and (3) absence of general tuberculosis. All reporters speak of the tendency of the joint to become more or less flexed unless a posterior splint is used for a long time. What is the real value of the operation further experience and time alone can determine.

The advantages claimed for arthroectomy are that the bones are not interfered with, and shortening does not take place, that erosion is not a bar to future excision, and that the patient is not placed in a worse condition by the operation. It is justifiable at an earlier period of disease than an excision, and is peculiarly applicable to children. On the other hand, it perhaps encourages a too early operation in cases that might be cured by non-operative treatment. The tendency is towards more early interference in joint-surgery, and there is great danger that we may be going too far.

**Arthrotomy** consists in the removal of all infected tissue, together with a section from the articular ends of both the femur and the tibia, without any reference to whether they are diseased or not, so that the two bony surfaces may be brought into contact and osseous union be obtained. Until within the last few years it has been the only operation for disease of the knee-joint except amputation, and for a long time the question was whether to amputate or to excise. Within the last ten years excision has become not a substitute for amputation, but an operation which may be taken into consideration at an earlier date than an amputation is to be thought of, and which aims to secure to the patient a limb not much shorter than the sound one, but with ankylosis at the knee, and one on which he can walk without any pain and with but a slight limp. It is not often performed for disease among the better class, because the joint-disease seldom advances to a degree that calls for any radical operation. It is confined mainly to those among the lower class in whom the disease has been allowed to advance until the articulation has become completely disorganized, the tibia displaced, and the bones seriously involved, or in whom the joint is filled with granulations, the ligaments destroyed, and the bones involved to a greater extent than can be thoroughly removed by erosion,—in fact, to those cases where disease has begun in the bone, so that nothing short of a complete eradication of the disease will put the parts in such a condition that a cure with a useful limb is possible.

There are two conditions of the knee-joint in which a classical excision is the only remedy: in an old posterior dislocation, owing to the changes that have taken place in the femur and tibia, and the shortening of the soft parts behind the knee, a removal of sections from both bones is absolutely necessary in order to bring the leg in a straight line with the thigh; the other is bony ankylosis in a flexed position.

In children under six years of age excision is not a satisfactory operation: the liability to excessive shortening is great, and the danger from general tubercular infection is greater than in those above that age: at least such has been my experience. There can be no doubt that a short limb with a high shoe is a far more useful member than the best artificial limb that

can be obtained. There is no danger of ulceration from pressure, no constant expense for repairs and replacement. The usefulness of a limb after excision with bony union is excellent, and it would seem that the objections raised against the operation as now performed are altogether too strong.

*Operation.*—The parts should be thoroughly disinfected. The joint may be opened by a U-shaped incision either above or below the patella, or by some operation like the transpatellar method or the longitudinal. It is better not to use an Esmarch bandage: simply raising the limb for a minute or so and then applying a constricting band will render the limb almost bloodless, and there is not the troublesome oozing that follows the use of a rubber band from the foot to the thigh.

Having exposed the joint, the leg should be well flexed, so that the whole articular surface shall be exposed. All diseased tissue is then to be removed thoroughly with scissors or knife; and the synovial sac above the patella must be dissected out. During the operation the parts should be frequently flushed with mercuric solution. The patella should always be removed, for if the disease of the joint is extensive enough to demand an excision the patella is generally found to be diseased. In two cases in which I left it, a subsequent operation had to be performed for its removal, as it had become diseased. Mr. Marsh and others advise its being retained in patients over eight years of age.

Having removed all diseased soft parts and scraped out all sinuses,—or, better, dissected them out,—the ends of the bone are to be removed. This is best done with an amputating saw. The bone must be cut at a right angle to its long axis. The patient lying on his back, an assistant holds the femur perpendicular to the operating-table, being careful not to allow any lateral deviation, and a section is then made. The same plan is adopted in regard to the tibial section. The amount of bone removed should be as small as possible. If not enough has been removed at first either to eliminate the disease or to allow the tibia to be brought forward, further section should be made. If after making a section a caseous mass, an abscess, or necrosed and carious bone is opened into, it can be removed with a spoon, even if a large cavity is left, provided all infected tissue is removed, without any fear of jeopardizing the result of the operation. The amount of curetting that is compatible with a good result is almost unlimited, provided the outer shell of bone is left healthy. If there is necrosed bone extending up the shaft, it can be removed. No more healthy bone should be taken away than is absolutely necessary.

Having seen that the two cut surfaces come together without any tension upon the tissue back of the joint, the constricting band is removed, and any bleeding point ligated. There will be considerable oozing, which may be stopped by the application of hot water. The parts are then to be thoroughly flushed with mercuric solution. After the hemorrhage is stopped, the limb is to be placed upon some form of posterior splint, for the secret



of success depends upon absolute fixation of the parts. There are many ways of accomplishing this.

Some use plaster-of-Paris bandage extending from the foot to the groin, with an interval at the point of operation, the two portions of the splint being united with iron bars bent so as to allow of the wound being easily reached. Dr. McBurney applies to the leg and thigh a slight plaster bandage a day or so before the operation, and after it has become dry removes it by cutting it up in the median line. After the operation these leg- and thigh-pieces are slipped on, and the bracket put in position, and over these is applied another plaster bandage. The advantage of this method is that there is a firm basis to apply the iron brackets.

Many use some modification of Watson's splint. For some time I have used a splint made in two parts, one for the leg and one for the thigh, united by two side brackets. It has worked well. After being well padded, the leg portion is secured by a plaster-of-Paris bandage which includes the foot; the upper portion is secured with a coaptation splint placed upon the anterior aspect of the thigh and fastened with two straps and buckles. Do what you will, the upper portion of the splint will get soiled by the discharge running down, and if the thigh is encased in plaster it cannot be cleaned; whereas with the coaptation splint and buckles this can be easily accomplished.

All splints should be padded, and the leg should be somewhat raised, so that the cut surface of the tibia may lie easily against the corresponding surface of the femur. The whole limb is then placed upon an inclined plane, and the parts are brought into coaptation by position, and not by bandaging. Whatever form of splint is used, the foot must be fixed and well raised, so that it shall not sag down and displace the lower fragment. To hold the bones in position many use silver wire or steel nails plated with gold or nickel. The latter should be four and a half inches long and in size corresponding to No. 2 Stubbs's steel gauge; they may be round or square. They should be thoroughly disinfected. Three are generally used, one being driven in from either condyle downward and backward towards the middle of the bone, and one from the middle of the anterior surface of the tibia upward and backward. If they have been properly applied, any movement between the cut surfaces of the bone is impossible. The use of these nails certainly gives additional security to the limb, but it is not a necessity.

It is well to use four drainage-tubes,—two for the sac above the patella, and two at the end of the incision on the side of the limb, so as thoroughly to drain the posterior part of the joint. The incision is brought accurately together with catgut, and over it is placed some iodoform gauze, and then an ample covering of antiseptic gauze bound on tightly.

After the patient has been returned to bed it is well to suspend the whole limb.

The amount of pain after an incision of the knee-joint is not very great

if the limb is put up so that there is no uneven pressure and the splint is well padded. Opium will be required the first night, and possibly the second. Theoretically, the temperature should not be elevated if the operation has been done strictly antiseptically; in some cases, however, notwithstanding every precaution, it will be found a little above normal on the following day or the next, but it soon goes down, and if everything goes well there is no further rise. One of the chief causes of trouble and after-pain is an accumulation of blood and serum in the space left by the removal of the synovial sac above the patella. To prevent this, strict attention to the drainage of this sac is required, with care that the tubes do not get constricted by the bandage.

On the day following the operation the dressing will have to be removed, on account of its becoming filled with blood and serum; the iodoform gauze need not be disturbed. After the second dressing it is not often that it has to be removed unless it gets loose. About the third week the nails may be removed; they are usually found loose, and there is no difficulty about it. If abscess has formed, it should be evacuated at once and the parts disinfected. The time necessary for firm union to take place is from eight to twelve weeks.

I have excised seventeen knee-joints, as shown by the table on the following page. Of these cases ten were cured, four died, one was discharged with limb ankylosed but with discharging sinuses, one is incomplete, and in one amputation had to be performed. The cause of death in three was general tuberculosis; one died from heart-failure twenty-four hours after the operation. Of those who were discharged cured, eight are known to be alive and have useful limbs; they have no pain, and walk well without the use of a crutch or cane. Two are known to have died, one from general tuberculosis five years after leaving the hospital, and one from diphtheria eight months after her discharge. In only one case has the union been fibrous, and that was in the child who died from diphtheria, but no flexion had taken place.

The shortening in the case of the boy sixteen years of age, who had been diseased since childhood, was mainly due to arrest of growth; in two cases it amounted to two inches, in two to two and a half, in two to one and a half, and in three to one inch. In regard to the growth of the limb after excision, I have re-examined six patients. In case No. 2 there has been no change for fourteen years; in No. 4 there has been an increase of one and a half inches in seven years; in No. 5, no change in four years; in No. 6, an increase of one-quarter of an inch in six years; in No. 7, an increase of half an inch in four years; and in No. 12, no change in two years.

In one case the limb had to be amputated on account of chronic inflammation in the bone. I am unable to account for this, as it was a case of old dislocation and ankylosis; there was nothing about the bone or the operation to account for the disease in the bone; there were no tubercular foci, the disease being non-tubercular. The fact that during the first night

## EXCISION OF THE KNEE.

No.	NAME.	AGE.	CAUSE OF OPERATION.	EXCISED.	RESULT.	SHORT-ENING.	REMARKS.
1	A. G.	16	Ankylosed at right angle fourteen years.	June, 1878.	Cured.	4 in.	Has not been heard from since 1880, and then was well.
2	J. S.	14	Ankylosed at right angle, abscess eight years.	Nov., 1879.	Cured.	2 in.	Seen in 1886; good use of limb; does not wear a high-shoe.
3	R. P.	3	Tubercular osteitis, abscess.	Dec., 1883.	Relieved.	.....	Wound never closed, but patient was still alive in 1888.
4	M. F.	12	Ankylosed at right angle, abscess.	March, 1881.	Relieved.	2 in.	Well in 1889; short two and a half inches.
5	J. R.	10	Ankylosed at right angle, abscess.	Feb., 1882.	Cured.	1½ in.	
6	G. R.	13	Tubercular synovitis, abscess.	May, 1883.	Cured.	2½ in.	Later had curve of spine and tuberculosis; died in 1887.
7	H. S.	7	Tubercular synovitis, abscess.	May, 1882.	Cured.	1½ in.	In 1887, short one and three-quarter inches; had curve of spine before operation.
8	J. H.	4	Tubercular synovitis, abscess.	June, 1883.	Died.	.....	Tubercular tumor of brain.
9	L. S.	3	Synovitis and total disorganization.	June, 1883.	Died.	.....	March, 1884, curve of spine; wounds closed; union firm.
10	A. J.	13	Synovitis and disorganization.	June, 1885.	Died.	.....	General tuberculosis; wound never closed.
11	E. H.	8	Angular deformity, ankylosed.	Nov., 1885.	Died.	.....	Amputation for osteo-myelitis.
12	M. M.	14	Angular deformity, diseased four years.	Nov., 1885.	Cured.	.....	In 1888 no change in shortening; walks well.
13	L. G.	11	Tubercular osteitis, abscess.	Oct., 1886.	Cured.	.....	Died eight months later, of diptheria; union fibrous.
14	E. B.	8	Infantile paralysis.	Nov., 1886.	Cured.	.....	Result good.
15	K. F.	13	Tubercular osteitis.	June, 1888.	Cured.	.....	
16	K. D.	7	Tubercular disease.	May, 1887.	.....	.....	In hospital.
17	A. H.	7	Tubercular disease.	May, 1887.	Died.	.....	Collapsed twenty-four hours after operation.

after the operation the patient tore off the bandage may account for it, as suppuration almost immediately followed.

Case 7 was admitted with tubercular synovitis following a slight injury; the joint presented the characteristic swelling, there was an absence of any pain even on motion, and the skin looked very white; the case was looked upon as being very unpromising. Excision was performed, and all went well for a time, when the spine was discovered to be diseased. The operation-wound closed, and he had good use of his limb. Finally the lungs became diseased, and he died five years after the operation. Case 8 was a child four years of age, with tubercular disease of the synovial membrane and an abscess in the head of the tibia, not surrounded by any sclerosed bone. The wound never did well; disease in the bones continued; after some months brain-symptoms developed, and at post-mortem examination a tubercular tumor of the size of an English walnut was found in the brain. Case 9, a child three years of age, was admitted with tubercular synovitis and osteitis; the parts about the joint were greatly swollen from the middle of the thigh to the middle of the leg; the joint was completely disorganized. Excision was performed; some time later, as suppuration continued, the parts were examined and a sequestrum in the femur was found between the bones; one month later disease of the dorsal vertebrae was discovered, and the patient died. Case 10, a boy of thirteen, had tubercular disease of the synovial membrane of the same character as case 7; excision was performed after abscess had formed; the wound never closed, and he died of pulmonary tuberculosis six months after the operation.

Cases 7, 8, 9, and 10 were unpromising at the time they came under observation, and perhaps belonged to the class in which amputation should have been performed; in this an error may have been made. The question whether infection of the lungs, brain, or vertebrae was caused by manipulation during the operation is difficult to answer, but the possibility of the occurrence of such infection cannot be lost sight of.

Of the death from heart-failure I can offer no explanation. The child was in good condition,—the excision was performed to correct a malposition,—but little blood was lost, and the operation was not a long one. Early in the operation the heart acted badly, and, notwithstanding the free use of hypodermics of digitalis and whiskey, it never regained its force, and the patient died twenty-four hours later from heart-failure. Shock alone did not seem to be the cause.

Quite a number of operators speak of bending of the limb at the point of section some time after the patient was going about. Barwell<sup>1</sup> mentions the case of a boy fourteen years old in whom the union was not bony. Bryant<sup>2</sup> reports the case of a child six years of age on whom three years previous an excision had been performed; the tibia had become bent to an

---

<sup>1</sup> Diseases of the Joints, 5th ed., p. 562.

<sup>2</sup> British Medical Journal, 1884, vol. i. p. 1045.

angle of sixty degrees upon the femur; there was no motion at the time of readmission. The malposition was corrected by an osteotomy through the femur. Morgan<sup>1</sup> reports the case of a girl twelve years of age whose knee-joint had been excised one year previous, and in whom the limb had gradually become flexed to a right angle. Baker<sup>2</sup> mentions the case of a boy who when nine years of age had his knee-joint excised. Nine years later the leg was gradually bending; the union seemed firm, yet the limb had bent to an angle of forty-five degrees at the knee. Smith<sup>3</sup> reports the case of a boy eleven years of age in whom excision was followed by bony ankylosis; five years later the limb was bent forward at the point of operation and the tibia and femur were curved. In another boy when five years of age a similar operation had been performed; thirteen years later the limb became bent forward. Howard Marsh<sup>4</sup> mentions a case where at the point of operation the limb became flexed. From an examination of the plate illustrating this, the bending seems to have taken place at the point of operation, the anterior portion of the bony union having become elongated. Phelps<sup>5</sup> reports a case in which the limb was put up in a slightly-flexed position after an excision in a child nine years old; the patient did well, but eight months later the limb became flexed to an angle of forty-five degrees. The child suffered pain at the point of excision during locomotion and on any attempt at straightening the limb. Phelps considered the bending to be due to the action of the hamstring muscles, and advises their resection in all cases, and utilizing the patella to overcome any flexion.

From a review of these cases, there does not seem to be any common cause to account for the bending. In some cases the deformity did not make its appearance for some years after the operation, while in others it came on earlier. It is reasonable to suppose that in Dr. Phelps's case the slightly-flexed position in which the limb was placed might have been an element in causing the deformity. In my own experience no case of bending has been seen, nor do I know of any case in the experience of any one except Dr. Phelps where this accident has occurred. It is known that in some cases after a fracture has finally united bending at the seat of union has taken place, and perhaps the bending at the seat of excision at the knee-joint is due to the same cause. The best safeguard against this accident consists in perfect fixation and coaptation of the bones, and in seeing that the limb be put up in a straight line.

*The ultimate use of the limb* after excision of the knee-joint is good even when the shortening is excessive. After excision in children the amount of increase in the shortening depends upon the point at which the section

---

<sup>1</sup> British Medical Journal, 1879, vol. ii. p. 317.

<sup>2</sup> Ibid., 1887, vol. i. p. 322.

<sup>3</sup> Medical Times and Gazette, 1880, vol. i. p. 29.

<sup>4</sup> Diseases of the Joints, p. 326.

<sup>5</sup> Medical Record, 1886, vol. xxx. p. 113.

of the bones is made,—whether the epiphysial cartilages are left or not. When both epiphysial cartilages are removed in young children, the arrest of growth is great. Holmes<sup>1</sup> mentions the case of a man on whom nineteen years before he had excised the knee-joint for extensive disease accompanied by imperfect ankylosis. The patient was then a child, and both epiphyses were removed. The limb is now seven inches short, yet it is so serviceable that he can walk thirty miles in one day. Lee<sup>2</sup> reports the case of a man on whom twenty years previous, when twelve years of age, he had performed excision. When discharged, the shortening was five inches; now it is nine inches; the patient walks well with a patten on his shoe. It would appear, then, that excessive shortening is no bar to a very useful limb. In only a few of my own cases has a sufficient time elapsed since the operation to afford grounds for reliable statement on this point. In one case, for ten years the patient has had excellent use of the limb, and at one time acted as a line-man for a surveyor and did his work easily. He is now an architect, and goes about buildings under construction without any difficulty. Marsh makes the statement, “The limb after excision, especially in children under nine or ten, is very unsatisfactory; it remains short and becomes in many cases distorted.” I know of no case in which a good limb has not been obtained, although the amount of shortening varies. Even in those cases in which it has been excessive a high shoe has permitted the patient to undergo much fatigue without any failure of the limb. Bending does not appear to be common in this country. Perhaps the better food and surroundings which the children of the lower class have here conduce to a better and firmer bony union.

In comparing excision with amputation, there does not seem to be any question that the ultimate result of excision with good union, no matter how great the shortening may be, far exceeds both in usefulness and in comfort the best artificial limb made. The sole of the foot affords the best possible support.

A few cases of motion after excision of the knee-joint have been reported. Bennett<sup>3</sup> reports the case of a girl in whom, two years previous, he had excised the knee-joint. “She can stand upon the limb without support, and can flex it to a right angle.” She walked with a little limp. Boutflower<sup>4</sup> mentions a boy seven years of age in whom the knee-joint was excised for deformity; the patella was removed. Nine months later there was motion at the knee-joint over an angle of ninety degrees. It does not appear from these cases that the motion was of any use. From the fact that the patella had been removed in both cases, it is hard to understand how the patient could derive any benefit from this condition.

The accidents that happen in connection with excision of the knee-joint

---

<sup>1</sup> British Medical Journal, 1880, vol. i. p. 225.

<sup>2</sup> Lancet, 1888, vol. i. p. 769.

<sup>3</sup> Ibid., 1884, vol. ii. p. 235.

<sup>4</sup> Ibid., 1884, vol. i. p. 889.

are suppuration, necrosis, caries, and hemorrhage. A limited necrosis is sometimes seen for which no cause can be assigned; it does not necessarily jeopardize the success of the operation, but delays the cure. Hemorrhage of a serious nature has been reported in some cases, from ulceration of the popliteal artery due to pressure or to a spicula of bone. Gangrene of the limb has been met with, from compression of the artery due to stretching of the parts behind the joint. Secondary hemorrhage sometimes occurs.

Disease of the bone after excision is met with. It may be due to infection at the time of the operation, or to improper dressing. Movement between the fragments may cause trouble; or a tubercular deposit that has either escaped notice from being situated beyond the point of section, or has not been thoroughly scraped and disinfected, may rekindle the disease. If much suppuration occurs, it is best to open the wound and search for its cause. If it is due to tubercular foci, these may be removed and the wound closed again, after which the case may progress to a favorable termination. If the cut surface of the bone becomes diseased, the parts may be re-excised, but not with much prospect of success, so far as my experience goes.

Amputation for knee-joint disease is not so often performed as formerly, yet in some cases it is the better operation. In cases of injury to the popliteal artery, where the bones are extensively diseased, where the lungs show considerable tubercular deposit, where the joint is enlarged and the skin very white, amputation of the knee-joint may be demanded.

What are the indications demanding excision of the knee-joint?

Ankylosis in a flexed position can be corrected only by an operation, either by removing a wedge-shaped piece of bone, including the ends of the femur and tibia, or by a subcutaneous osteotomy of the femur or of the femur and tibia, one-half of the deformity being corrected by the first section and the rest by the second. This leaves the portion between the two points of operation very prominent, but this in time is somewhat decreased by moulding of the parts. There is, however, danger that the vessels behind the joint may be compressed in correcting the deformity. Old dislocation of the tibia backward can be corrected only by excising the joint.

Excision of the knee-joint for disease is rarely called for among the upper and middle classes, because the disease is seldom allowed to advance to such a state that a cure cannot be obtained without an operation. When suppuration is profuse and long continued, or when in a patient of marked tubercular antecedents the disease does not yield to proper treatment, an operation, even among the better class, should be performed. In cases where the joint has become painlessly enlarged and the skin has an abnormal whiteness, excision is demanded early, and, if the wound does not do well, should be followed by amputation. Where we are satisfied that an abscess in the end of one of the bones has opened into the joint, or has opened outside of the articulation, nothing but the removal of the diseased bone will stop the discharge. Chronic suppuration calls for an exploratory operation, and if the parts are found to be in such a state that a cure by rest is

improbable, erosion or excision should be performed. The choice between these two methods depends upon the condition of the bone. The more the disease is confined to the synovial membrane, the better will be the prospect that erosion will eradicate the disease; on the other hand, the more the bones are involved, the more appropriate is an excision.

In case granulation should appear either in an old sinus or by the side of a drainage-tube, the patient should be placed under ether and the sinus scraped.

#### HYDRARTHROSIS.

Hydrarthrosis signifies merely fluid in a joint, without conveying any information as to its cause or amount. The word is, however, used to designate a chronic painless or almost painless distention of a joint with synovia, which may only be thinner than normal or may be filled with fibrinous exudation. In some cases the membrane may be thickened, and in older children the synovial fringes may become hypertrophied. The disease is almost always confined to the knee-joint, or at least it is much more commonly met with in that articulation, although it may be found in the shoulder, elbow, and ankle joints. It may be the result of a chronic synovitis or may follow articular rheumatism; there are some cases in which no cause can be assigned.

The knee-joint is often greatly distended. It is stated that it sometimes contains eight or nine times its normal amount of fluid. In cases of long standing the capsule may become greatly thickened and the ligaments softened and weakened, so that there is considerable lateral movement in the joint, and the articulation gives way when any weight is put on it. The joint in this condition shows little tendency towards recovery.

**Treatment.**—When the effusion is comparatively recent, rest to the joint by means of a posterior splint and the application of small fly blisters every few days, together with pressure by means of an elastic bandage, may in a few cases effect a cure. In a more advanced condition there is nothing better than injection of the joint after the withdrawal of the fluid, in the following manner.

Having placed the patient under ether and thoroughly disinfected the skin, a small incision is made on the outer aspect of the joint through the skin, and then a good-sized trocar, which has been made perfectly aseptic either by being placed in a solution of carbolic acid (one in forty) or by heat, is plunged into the joint-cavity, and as much of the fluid as possible withdrawn by equable pressure over the joint, so as to prevent the entrance of any air; the joint is then injected through the canula with a warm solution of carbolic acid (one in sixty) by means of a fountain syringe, until the synovial cavity is well distended; the fluid is then allowed to flow out, and this is repeated until the fluid runs clear. It will be noticed that the first injection will come out of an opaline color, due to the coagulation of the fibrin; the second will be less so, and finally it will come out clear or nearly so. During the operation the joint is to be kneaded, so that the fluid shall gain access to the whole cavity. Gerster advises that the first few



washings be made with Thiersch's fluid (salicylic acid two parts, boracic acid twelve, hot water one thousand), and the final flushing done with carbolic-acid solution, because the latter hardens the fibrin and renders it difficult for it to pass through the canula. After the operation is completed the canula is withdrawn, and the incision covered with iodoform gauze, and over this a dry sublimate dressing; finally bandages and a posterior splint are applied. The patient should be kept in bed for ten days, when the dressings are removed and the patient is allowed to move the joint in bed, and within a few days to get up.

I have used this method in three cases, and have every reason to be perfectly satisfied with the result. There is, as a rule, no pain after the operation, nor are there any ill effects. Care must be taken that the limb is not kept quiet too long, lest the thickening of the synovial sac be so great as to limit motion.

In case the first operation does not accomplish the purpose, a second or a third may be done.

---

## NON-TUBERCULAR DISEASE OF JOINTS.

Under the titles of epiphysitis, osteitis of growing bones (Macnamara), epiphysal necrosis (W. M. Baker), necrosis of the extremity of the diaphyses and epiphyses of growing bone (Eve<sup>1</sup>), has been described an acute, sub-acute, or chronic non-tubercular inflammation of the articular ends of the long bones, often going on to the formation of an abscess and sequestrum and in many cases causing inflammation and destruction of the neighboring articulation. There is no question that there is an epiphysitis of tubercular origin,—in fact, many cases of strumous disease of the bones entering into the formation of joints begin in or about the epiphyses,—but the class of cases now referred to do not belong to this category. The subject is one of importance, and a clear understanding of its pathology, symptoms, and clinical history will throw light upon many cases of joint-affection. Perhaps the term osteitis of growing bones is the more correct, because the epiphyses are not in all cases the real seat of disease, the trouble being sometimes entirely on the diaphysal side of the epiphysal disk. But in the vast majority of cases the epiphyses are either primarily or secondarily involved; the symptoms and influence upon the integrity of the neighboring joint are almost identical whether the disease begins on the one side or the other of the cartilage existing between these two portions of the bone. The term epiphysitis will be used, meaning thereby disease of the bone in the neighborhood of the epiphysal disks. Although epiphysitis is strictly an affection of the bones, yet the situation of the point of the disease is in such close

---

<sup>1</sup> St. Bartholomew's Hospital Reports, vol. xv. p. 125.

proximity to the joint that the articulation is readily affected; and this fact gives to the study of osteitis in the ends of bones an importance equal to that of primary disease of the joint itself.

Epiphysitis is a disease of childhood. The peculiar construction of the articular ends of the bone, the active nutritive processes going on in these parts, and their low resisting power predispose the parts to inflammation and necrotic changes. "The medulla filling the areola of the spongy tissue is the real seat of the inflammation; in it we have increased vascularization with exudation. In this condition the parts may remain for some time. In many instances pus is early formed in the vascular medullary tissue; the trabeculae, which at first maintain their structure, not infrequently necrose. A line of demarcation is formed between the dead and the living portions."<sup>1</sup> In other words, we have a local osteo-myelitis. If the process goes on, a time comes when the circulation will be cut off from a portion of the bone in the centre of the inflammatory area, and its local death will take place, to an extent depending upon the amount of disease; and thus we have at times a sequestrum enclosed in a cavity, with pus between it and the living bone. The tendency of these bone-abscesses is in time to make a way for themselves through the bone and discharge, the amount of local trouble depending upon the acuteness, situation, and duration of the disease. If they are very acute, they soon involve more of the osseous tissue, break through the limiting exudation, and make their way rapidly to the surface in the direction of least resistance, often involving the soft parts; if, on the other hand, they are more chronic in their course, the bone will be slowly thickened and condensed, and it may take years for the abscess to reach the surface.

Between these two types there is every shade of variation. The joint is involved only secondarily. In very acute cases it may be almost impossible to separate the bone- from the joint-trouble, while in more chronic cases the articulation is affected only after some time or not at all. The disease may attack the epiphyses alone, or the articular end of the diaphyses, or both may be involved.

The origin of these cases is often an injury near a joint, as a sprain or a blow. The patient within a day or so complains of acute pain and tenderness over the bone near the articulation, or the symptoms may come on suddenly after the patient has been exposed to wet or cold. There is often swelling about the joint, at times extending up or down the limb beyond the seat of injury. Soon the joint becomes distended, and, if relief is not at once afforded, the articulation is destroyed. Sometimes the case does not pursue so rapid a course, the pain and tenderness upon pressure are much slower in showing themselves, and the swelling of the joint does not appear until much later, or the joint may not become directly affected, as in the following cases.

---

<sup>1</sup> Jones, *op. cit.*, p. 93.

*Case I.*—A boy eight years of age was admitted into St. Mary's Hospital, giving the following history. Six weeks before coming under observation he was run over by a cart, the upper end of the tibia, near the tubercle, being bruised. In a few days he began to have considerable deep-seated pain in the head of the tibia, the joint became swollen, and finally an opening formed on the anterior aspect of the bone just below the tubercle of the tibia, from which, at the time of admission, there was a discharge of pus. There was seen a small sinus just below the point of attachment of the ligamentum patellæ, through which necrosed bone could be detected. The upper part of the tibia was considerably enlarged. The patient was etherized, and the upper portion of the tibia was found to be converted into a large cavity containing many sequestra. The cavity was bounded above by the epiphysal cartilage and lined with sclerosed bone. In this case the process has been slow, and, although there had been effusion into the joint, the abscess did not communicate with the articulation, being limited above by the epiphysal cartilage, and the joint was only affected by contiguity of tissue.

*Case II.*—A girl seven years of age came under my care in 1881, with the following history. From some unascertained cause, three years previous she experienced great pain at the lower end of the femur, with marked constitutional disturbance. Later the joint became inflamed, and an abscess opened just above and to one side of the patella. After discharging for some time, the swelling of the joint disappeared, but there has always been some slight discharge from the sinus. No further history could be obtained. The tibia was found dislocated backward upon the condyles flexed to a right angle. The lower portion of the femur was much enlarged. With the patient under ether the sinus was found to connect with the knee-joint. An opening was then made into the articulation; the cartilages were comparatively healthy except at a point between the condyles near their posterior surface, there was exposed bone, and in this was a sinus extending up the shaft of the femur. The soft parts were then detached from the anterior aspect of the bone, and its anterior surface chiselled out so as to expose the sinus. In this way it was laid open almost to the joint. A sequestrum was found in a cavity about the size of a hazel-nut, loose, and consisting of cancellous bony tissue. The sequestrum was just above the epiphysal cartilage. The following evidently was the pathology of the case. From some cause there had been a local osteitis just above the epiphysal disk; this had caused a necrosis of a small portion of the cancellous tissue; later an abscess had formed which finally had opened into the knee-joint, causing suppurative inflammation; the abscess then perforated the capsule and made an opening near the patella where the sinus was found. The abscess in the bone caused it to become inflamed and enlarged. In other words, there had been an acute epiphysitis, followed by inflammatory enlargement of the end of the femur.

*Case III.*—Recently there has been under my care a child four years of age who, following measles, had disease in the epiphyses of both femur- and wrist-joints, with necrosis. The lower portion of the left femur was considerably enlarged; there was a sinus discharging considerable pus situated just within and under the biceps. On cutting down upon the bone from the lateral aspect of the thigh, an opening was found at the epiphysal line large enough to admit the finger, and leading into a cavity which represented the entire epiphysis, there being only a thin shell of bone separating it from the joint. Within this cavity there was found a sequestrum of the size of an English walnut, representing in shape the bony portion of the epiphysis. There had been an acute epiphysitis at the lower end of the femur, with the death of a small portion of the cancellous bony tissue. The accompanying abscess had made its way into the knee-joint, causing a purulent synovitis. The sinus would not have closed until the sequestrum had been removed.

*Case IV.*—A child two years old was admitted into St. Mary's Hospital for children during the last year, with the history of an acute swelling on the anterior aspect of the thigh and about the hip-joint. She had complained of no pain and had no lameness until four weeks before admission, when she was seized with acute pain about the hip, accompanied by inability to use the limb. On admission the upper part of the thigh was much swollen and the trochanter was above Nélaton's line. The abscess on the anterior aspect of the thigh was opened; it could not be found that it communicated with the articulation. The hip-joint was then exposed; the capsule was full of pus, and the epiphysis was found

loose in the joint-cavity; it was not diseased, and appeared as a smooth disk of bone; the neck did not show much disease.

Epiphysitis may follow a much more acute course. Macnamara<sup>1</sup> reports the case of a boy nine years of age who had, a fortnight before coming under observation, received a severe blow over the region of the great trochanter; he suffered severe pain at the time of the injury, especially when he attempted to move the limb; the pain was, however, less the next day. On the night of the tenth day after the accident, while in bed, he was suddenly seized with violent pain in the injured hip, and three days later was brought to the hospital. His temperature was 103° and 105° F.; his left thigh was slightly flexed and abducted; any attempt to move the limb caused violent pain in the joint, as also did the slightest pressure applied directly over the head of the femur. The patient's thigh was not swollen. During the night the boy was delirious. On the second day after admission the joint was laid open, so as to afford efficient drainage. On passing the finger into the joint "the neck of the femur at its lower part was found separated from the epiphysial cartilage, so that there was a free opening through which pus in the cancellous tissues could escape outward. The patient's temperature fell during the evening. He was discharged at the end of the fifth week, able to walk about without the slightest inconvenience, the movements of the hip-joint being perfect."

Another class of acute cases follow a different course. The pus may get under the periosteum, and strip it from the bone to a greater or less distance; and finally it may perforate that membrane and form deep-seated abscesses in the soft parts, a considerable distance from the point of disease. In these cases the nutrition of the bones does not suffer much at first, and if prompt relief is afforded the parts recover.

In a third variety of cases—namely, those which follow a chronic course—it may be months or even years before the abscess in the bone discharges, or the pus may never be able to reach the surface, on account of the inflammatory hypertrophied processes that it has caused in the bone. These are the cases of abscess of the bone described by Brodie. Some of the cases he reports began as an epiphysitis during childhood. The latter form of bone-disease often begins in or near the epiphysial cartilage, usually from an injury. The symptoms may be at first acute, with much pain; there may be a bruising of the bone or an extravasation of blood, followed by inflammation, then death of a small piece of bone; the more urgent symptoms may then disappear, but the foreign body causes a subacute or chronic inflammation of the bone, followed by hypertrophy. The after-history of these bone-abscesses, so far as the joint is concerned, varies according as the pus works its way towards the articulation or the inflammation of the bone extends to the joint; and thus a very troublesome and rebellious joint-affection is set up.

---

<sup>1</sup> British Medical Journal, 1888, vol. ii. p. 76.

The joint may be affected in one of two ways,—namely, by the opening of the abscess into the articulation, or by the extension of the bone-inflammation to the joint by contiguity of tissue. In the former class the articulation may be suddenly inflamed by the bursting of the abscess into that cavity, thus setting up an acute purulent synovitis; or there may be from time to time attacks of synovitis of a subacute character following an injury or excessive exercise, recovered from by rest for a few days, only to be succeeded by another attack and this again by another. These attacks leave the articulation less and less able to recover, so that in time it becomes permanently distended. Subsequently this serous synovitis may gradually assume a purulent character, so that when the abscess opens into it there will be no marked increase of the symptoms. If the joint is affected by the extension of the bone-inflammation, it may gradually become swollen, but not so markedly as in the case of serous synovitis; it is tender and painful; gradually it becomes flexed and stiff. On opening such a joint, the articular surfaces are often found bound together by adhesions; there may be a slight increase of synovia, but the inflammation is chiefly of an adhesive variety, and recovery with any useful motion is very seldom seen. These are the cases of chronic inflamed joints which go on to ankylosis, either fibrous or bony, with dislocation of the tibia backward upon the condyles of the femur.

The affection may begin (1) just beneath the articular cartilage, (2) in the neighborhood of the ossifying centre of the epiphysis, (3) in the line of the junction of the epiphysis to the shaft, or (4) in the shaft near the epiphysal disk. The nearer the joint the affected tissue is situated, the sooner will it become involved.

**Symptoms.**—The symptoms of acute epiphysitis are marked, but they vary somewhat, depending upon the situation of the portion of the bone involved. If it is near the epiphysal disk,—that is, some distance from the joint-surface,—the joint will not be affected so early as when near the articular cartilage. The disease commences with intense pain and tenderness over the articular end of a long bone; sometimes this tenderness is confined to or is more marked in one spot. The soft parts are soon swollen in superficial joints, and the articulation itself is often enlarged and the limb flexed. There is a distinct increase of heat over the parts, and constitutional symptoms are marked. Pain is greatly increased by pressure over the bone or by any attempt at motion. Sometimes it is impossible to separate the bone- from the joint-symptoms, so rapid is the course of the disease. In those cases in which the point of the disease is within the articular cavity, it may be impossible to distinguish the disease from acute purulent arthritis.

Pus is soon formed, and in bad cases the inflammation rapidly involves all tissues,—the bone, the periosteum, the synovial membrane, and the soft parts. The epiphyses may become separated from their attachment to the shaft. In a few cases pus finds its way between the periosteum and the bone, and may separate them for a considerable distance from the point of

disease. In these cases the limb is more or less swollen, and may have a hard, brawny feel, resembling the condition found in acute osteo-myelitis; later the matter perforates the periosteum and forms abscesses among the muscles. Again, in cases not quite so acute the pus may perforate the bone either outward or into the joint; in the former event it will burrow among the muscles or remain within the periosteum. If it gains access to the joint, acute suppurative inflammation is at once set up, and the symptoms are those of intense purulent synovitis. The younger the child the earlier does the articulation become involved. With acute epiphysitis the constitutional symptoms are marked, the temperature is high, delirium is often present, and the child may die from pyæmia or septicæmia unless prompt relief is afforded. Sometimes the parts beyond the joint are greatly swollen, hard, and œdematous.

The symptoms attending subacute epiphysitis are not so marked, and in its earlier stage the disease may consist only of some pain or aching about the end of the bone; there may be some tenderness on firm pressure, as in those cases where the point of disease is near the surface of the bone. There is but slight if any increase of heat on the surface. The pain is apt to be worse at night. As the abscess approaches the surface the periosteum is swollen, giving the impression that the bone is enlarged; later bone-enlargement may actually occur. There are vague pains at intervals, and some limping in walking; pain often follows use of the limb, so that the patient is disinclined to move about. After rest the discomfort will often diminish, only to recur again upon use of the limb. As the disease advances there is enlargement of the bone, with increased tenderness on pressure and more pain on motion. The joint gradually becomes fixed, and finally the abscess perforates the bone and fluctuation can be detected and it discharges through the skin. If one of these sinuses is examined with a probe, dead bone can often be detected in the end of the bone. The cavity left by the discharge of the abscess varies in size: it may involve the whole articular end of the bone, or it may be confined to a portion of it. With these symptoms the neighboring joint is frequently affected: it will be swollen, tender, and hot. If the course of the abscess is towards the joint, the history is different: the attacks of synovitis are more frequent, marked, and persistent, until finally the abscess enters the joint, often through a very small opening; or the abscess may suddenly burst into the joint, and purulent synovitis be set up without any previous synovial effusion.

The symptoms of chronic epiphysitis are very indistinct, and are often overlooked. The pain is not marked, and is variable: it may be attributed to rheumatism. Gradually after months the end of the bone will become enlarged, and this increase in size may extend up to the shaft. There will be times when the child will complain of pain and walk with some limp; but the pain is not intense, nor is there much difficulty in walking; the pain is more frequently present at night. These symptoms may last for

years, the bone gradually becoming thicker and the discomfort more marked, yet the pain seldom being acute. It may not be until adult life that the true nature of the disease is recognized. With these bone-symptoms it may be years before the joint begins to give trouble, though it is tender, swollen, and looks ill shaped, the muscles are wasted, and the bony prominences are marked. It may be somewhat flexed and fixed in its abnormal position by adhesions caused by the chronic inflammatory process propagated from the disease of the bone. The patient is not confined to the house, but goes about with considerable limp; he may have to use a crutch or a cane; or after years the pain may be constant, with exacerbations, so as to confine him to his bed. If relief is not afforded, the disease is unlimited in its duration, or continues until the abscess in the bone finds an exit; but, as the osseous tissue has by chronic inflammation become greatly thickened and often sclerosed, it is impossible for the pus to travel outward, and operative interference offers the only relief.

Persistent or remitting pain, with or without tenderness on pressure about the articular end of the bone, is an important symptom, and, if accompanied by any enlargement, is diagnostic of bone-abscess. As the disease progresses the pain becomes more marked, and is accompanied by exacerbations, usually at night, and increased by previous exercise. The only condition with which it can possibly be confounded is neuralgia of the bone.

The results of epiphysitis, even when it is recovered from, may be marked. When it attacks the end of a bone at a point at which its normal growth takes place, it may cause an arrest of growth in the bone and marked shortening result. On the other hand, instead of causing arrest of growth, it may cause elongation of the bone, due to increased vascularity of the epiphysial cartilage. Marsh<sup>1</sup> calls attention to the fact "that chronic epiphysitis often lays the foundation of a very intractable joint-disease, especially of the knee. Cases are frequently met with in which children eight or ten years of age are found suffering with joint-disease which originated in the extension of chronic inflammation from the adjacent epiphysis when the patient was only two or three years old, and which, though there may have been periods of remission or even apparent recovery, has several times relapsed and the joint gradually become stiff, often deformed, and liable upon any exertion or disturbance of the health to a renewal of the synovial trouble."

Chronic disease of the epiphyses may apparently be recovered from, and the only indication of its existence for years may be a thickening of the bone and perhaps a scar denoting the point where an abscess has discharged, the patient and his medical attendant thinking that a perfect recovery has taken place. In after-years—it may be not until adult life—the bone may take on an acute inflammatory action, and unless the history has been care-

---

<sup>1</sup> Op. cit., p. 134.

fully considered the true cause of the inflammation may not be suspected. In these cases the joint is often involved.

**Treatment.**—The treatment of acute epiphysitis must be energetic and prompt. Absolute rest must be rigidly enforced; the limb must be thoroughly fixed by the use of splints, so that there shall be no motion whatever, either in the muscles or in the joints above or below the affected articulation. If there is much swelling, there must be no hesitation about cutting down upon the bone, and, if necessary, applying a trephine, under strict antiseptic rules. If the joint is distended with pus,—and this can readily be ascertained by the use of a hypodermic syringe,—it should be freely opened, washed out with mercuric solution (one in one thousand), and ample drainage afforded. If a diseased point is found in the bone, it should be freely scraped out with a Volkmann's spoon, so that all diseased bone shall be removed, and then thoroughly washed out with an antiseptic solution, a drainage-tube put in, the line of incision brought together with catgut sutures, and an adequate antiseptic dressing applied. It is well to dust the parts with iodoform and to place a piece of gauze impregnated with the same material over the line of the incision, and then the dressing over all. Even if no pus is found, the relief afforded by removing the tension and allowing the inflammatory products to drain off is great. That pus should be evacuated as soon as formed is a rule that applies with greater force in acute disease of the bone than in the same condition affecting any other tissue. If matter has burrowed up or down the limb among the muscles or has dissected off the periosteum, it should be evacuated by cutting down on the diseased point, the cavity disinfected, drained, and dressed as other wounds. After this operation the limb should be fixed again in splints and the dressings changed as soon as they have become soiled.

If the patient's condition does not improve, notwithstanding free drainage and perfect rest of the part, but, on the contrary, ground is being lost, amputation must be considered. In these cases, when the epiphysis has become detached and is loose in the joint-cavity, it should be removed. In all acute suppurative diseases of the joints and bones a supporting plan of treatment, with the free use of stimulants, is imperatively called for.

Where pus does not have free exit, there is danger of pyæmia and septicæmia, and the best way to anticipate their advent is the early evacuation and drainage of any and every collection of matter. In those cases in which the disease is so near the joint that infection of the cavity takes place at once, the treatment is that of purulent synovitis.

Subacute and chronic epiphysitis do not call for as active treatment as the more acute forms. In the early stage, before pus is formed, absolute rest to the limb by means of splints will often prevent further advance of the disease and effect a cure.

Fly blisters, or the Paquelin cautery lightly applied, may be of use, but rest must be our main reliance. If the pain continues and the bone is tender over a certain point, and especially if it is enlarged, pus has in all



probability formed, and a cure is impossible until it shall have been evacuated. With such a history, the best course is to expose the bone over the tender or enlarged point, apply a small trephine, and evacuate the abscess. In case the trephine does not strike the pus, a small curette or some sharp instrument may be thrust in different directions, and in this way the abscess discovered. It is then to be well scraped out, disinfected, drained, and dressed like other wounds. If a sinus has formed, it should be enlarged and a sufficient amount of bone removed, so that its cavity can be well curetted and good drainage afforded. In cases where we find the bone surrounding these cavities sclerosed, it is better not to perforate the hard shell, as thus we might enter the joint or start a new point of trouble in the bone. With proper treatment, subacute and chronic epiphysitis may never involve the joint and no further trouble may ever be experienced.

#### EPIPHYSITIS OF INDIVIDUAL JOINTS.

Epiphysitis of individual joints, except that of the hip, requires but short notice. Acute epiphysitis of the hip-joint is a serious disease: the articulation seldom if ever escapes. This is due to the anatomical fact that the epiphysis and neck of the femur are within the capsule, and any acute inflammation of this bone soon involves the articulation. The epiphysis is more liable to become detached from the neck than in any other joint, and when this occurs dislocation of the remains of the upper part of the femur almost always takes place upon the dorsum of the ilium.

The symptoms of acute epiphysitis of the end of the femur are acute pain, flexion, and generally abduction; the parts are soon swollen, and pus forms early in the course of the disease; there is marked constitutional disturbance. The abscess soon perforates the capsule, and, if unrelieved, forms large collections of matter in the soft parts, and this sooner or later discharges through the skin. Long before this the epiphysis has been detached from its connection with the neck and lies loose in the cavity of the acetabulum, and the upper end of the femur is drawn up by muscular action and position on to the dorsum of the ilium: this displacement of the remains of the neck of the bone may take place suddenly.

If one examines a joint under these conditions, it will be found, by traction of the limb downward, that the parts can be placed in their normal position, and, while there, crepitus can be detected from the rubbing together of the neck and the detached epiphysis; on withdrawing the extending force the decapitated neck again becomes dislocated upon the ilium. Sometimes the upper end of the femur will not leave the cavity of the acetabulum until the child begins to bear weight upon the limb, when it will suddenly become displaced and shortening be found. In some cases the sinus formed by the discharge of the abscess will close, and nothing will remain to denote the occurrence of epiphysitis but a displacement of the femur upon the ilium and a small scar the remains of the sinus. Unless carefully examined, the scar may be overlooked, and the cause of the mal-

position of the bone not be understood. Generally the sinus does not close, but continues to discharge more or less pus for an indefinite time, or until the necrosed epiphysis is removed. For a time the limb can be brought down and the shortening temporarily obliterated as long as the extension is kept up. But later the parts will form adhesions to the ilium, the shortening cannot be overcome, and the limb becomes flexed or adducted and often rotated outward, so that the child often has to use a crutch in getting about.

If these cases are seen early and the joint is opened as soon as the swelling becomes marked, the disease may be cut short and a recovery with a useful limb may result, as in the case of Macnamara mentioned on page 1231. But if not seen until the joint becomes disorganized, free incision will save the child much suffering and shorten the time of recovery, although it may not prevent dislocation. If the epiphysis is found loose, it should be removed and the limb held in position by extension, and, later, a hip splint applied and worn for a year or more, in order that the remains of the head and neck may form firm adhesions to the rim of the acetabulum and thus tend to prevent future displacement.

#### ACUTE EPIPHYSITIS IN INFANTS.

Acute epiphysitis in infants differs in some respects from that occurring in older children, not so much pathologically as in the rapidity of its course, the early implication of the joint, the intensely purulent nature of the inflammatory process, and its great danger not only to the integrity of the limb, but also to life itself. Mr. T. Smith,<sup>1</sup> under the title of "Acute Arthritis in Infants," first described this affection, and later Baker<sup>2</sup> and Marsh<sup>3</sup> have reported cases.

It is a disease of early life, and its interest consists in the liability of its earlier symptoms to be overlooked. Of thirty-four cases it was first noticed in one case on the fourth day after birth, in one on the tenth day, one on the twelfth day, one on the nineteenth day, one at three weeks, one at four weeks, one at five weeks, one at six weeks, one at seven weeks, two at nine weeks, one at ten weeks, one at two months, one at three months, one at four months, one at five months, six at six months, two at seven months, two at eight months, one at nine months, one at eleven months, two at one year, and one at thirteen months. Of these, seventeen recovered, some with perfect joints and some with considerable shortening and more or less crippling of the limb (one recovered after amputation at the lower third of the thigh), and sixteen died,—a mortality of a little over forty-five per cent. In only two cases could any cause be assigned, and in these the joint-affection came on after an injury. It is probable, however, that

---

<sup>1</sup> St. Bartholomew's Hospital Reports, 1874, vol. x. p. 194.

<sup>2</sup> British Medical Journal, 1883, vol. ii. p. 416.

<sup>3</sup> Diseases of the Joints.

traumatism is more frequently the cause of the disease than statistics would seem to prove. The tender age of many of the patients, and the ease with which any slight injury may be overlooked or the cause of the pain misinterpreted, tend to obscure the symptoms of the early stage of articular inflammation; moreover, it is often impossible to obtain a reliable history of these cases. The hip was primarily affected in eleven cases, the knee in fourteen, the shoulder in five; in one case both hip-joints were involved when the patient was first seen, in one the hip and shoulder, in one the hip and knee, and in one case (a child twelve days old) many of the epiphyses were found infiltrated with pus on post-mortem examination. The cause of death was either exhaustion or pyæmia, and with the latter two or more articulations were often affected.

The history of these cases is characteristic. After a day or so of fretfulness it will be noticed that the child does not use one of its limbs and that it will cry upon any movement of that extremity or of the body; in another day or two swelling around one of the joints will be observed; this will rapidly increase, and sooner or later, if not relieved, the abscess will open and discharge. With this there will always exist high fever and marked constitutional disturbances.

The etiology of this affection is not satisfactorily known. Marsh (*op. cit.*) states that it appears "sometimes to be due to pyæmia or some other form of blood-poisoning, and sometimes to injury during birth or to a subsequent strain or wrench." Owen expresses a similar opinion. From the identity of the lesions found at post-mortem examination with those of epiphysitis in older children, it is reasonable to attribute them to the same cause,—namely, in the vast majority of cases, traumatism,—and to suppose that the pyæmia so often seen is due to infection from the articulation first affected. Epiphysitis in infants is more rapid in its course than in older children, from the fact that the epiphyses are more cartilaginous and are situated more within the articular cavity than in those whose development is further advanced. The conditions found on post-mortem examination resemble those found in older children; but they all show, according to Mr. Smith, a considerable and rapid loss of substance in the articular end of one of the long bones entering into the formation of the affected joint. Sometimes a small abscess is found in the epiphysis communicating with the joint through a small opening; in other cases the whole epiphysis has been excavated, leaving only a shell of bone and a large irregular opening into the joint. If the disease is further advanced, the epiphysis may be detached and the inflammation extend to the end of the other bone. The articular cartilage may present an almost normal appearance except over a limited surface, where an irregular loss of substance may be found leading into a cavity in the bone; or there may be only a small "pin-hole" sinns in the cartilage, through which the contents of the abscess have gained access to the joint; while in more severe cases the whole cartilage may be destroyed and nothing remain but the end of the diaphysis. Sometimes

only the ossifying centre of the epiphysis is destroyed, or it may exist as a necrosed piece of bone. The abscess may be confined entirely to the epiphysis or may encroach upon the osseous structure of the diaphysis. Thus we have an acute osteitis of the epiphysis or the lower end of the diaphysis which has gone on to the formation of pus and death of the bone over a larger or smaller extent of surface. This abscess has burst into the joint-cavity through an opening of varying size, depending upon the location and extent of the local trouble; this has caused acute purulent inflammation of the articulation. In some cases the whole limb below or above the primary seat of disease may suffer.

There is a case reported by Brown,<sup>1</sup> of a child eight months old who was quite well in the evening, but became fretful during the night; the next day the knee-joint was swollen and exquisitely painful to both touch and motion. On examination the limb was found enlarged, semiflexed, and so tender that the least touch elicited cries from the patient. By the next day the swelling had increased and had extended up the thigh and down the leg, and by the sixth day the tumefaction was most marked from a point two inches above the patella down to the malleoli. An opening evacuated seven ounces of pus from the joint; the epiphysis of the tibia was found separated from the shaft. Later the limb was amputated through the lower third of the thigh. On examination of the amputated limb the epiphysis was found to be detached from the tibia, and the entire shaft denuded of periosteum and necrosed. There was a pin-hole opening through the epiphysis into the joint at about the centre of the external semilunar cartilage; the articular cavity was otherwise healthy. In the head of the tibia was found a cavity, and from this a small sinus leading to the joint; the whole diaphysis of the tibia was necrosed. In this case there was at first an acute epiphysitis, with abscess; this opened into the joint; then followed acute purulent inflammation of the periosteum of the tibia, due probably to an extension of the inflammation from the epiphysis, and subsequent death of the shaft of the tibia, the course of the disease being exceedingly rapid.

In the report of the post-mortem examination in other cases, lesions not so profound as those mentioned above were found.

**Symptoms.**—The attack is ushered in with restricted motion and usually flexion of the affected limb, followed by pain, swelling, and rapid suppuration within the articulation. The disease comes on suddenly, and, as a rule, runs a rapid course. Some cases have proved fatal in one week after the first symptoms were noted; in others an abscess has formed in the soft parts and opened within the same period. In Brown's case, cited above, the joint was disorganized by the fifth day, while in other more chronic cases the disorganization has not taken place for weeks. The swelling may be confined to the joint or may involve the parts above and below the

---

<sup>1</sup> Transactions of the Chirurgical Society, London, 1876, vol. iv. p. 175.

articulation. The constitutional symptoms are very marked. Sometimes the skin is red over the swelling; in other cases the hue is not changed until pus has perforated the capsule and is approaching the surface. Sooner or later, depending upon the acuteness of the attack, the matter perforates the capsule, and either finds an outlet almost immediately through the skin, or burrows among the muscles, forming often very large collections of pus. If free exit for the pus from the joint is not afforded, the articulation becomes completely disorganized, in the acute cases at least, within a few days. A joint may thus be hopelessly ruined within a day or so; while in less acute attacks it may be weeks before the capsule is perforated, and even in these cases a recovery is possible, with a perfect articulation. Where a spontaneous opening has been made by the pus, improvement is often very rapid, and the discharge ceases sooner than it usually does in cases of suppuration within the cavity of the joint.

The only disease with which acute epiphysitis can be confounded is acute rheumatism. Such being the condition of the bones in fatal cases, it has been asserted that acute inflammation of joints in infants which recover is not due to an epiphysitis, but belongs to another class of articular disease. On this point Mr. Baker (*op. cit.*) makes the following statement. "It may be said in cases of acute arthritis of infants in which recovery takes place, that necrosis is assumed without sufficient reason, while perhaps the fact is rather that recovery is an indication that no actual death on the part of the bone has occurred. It may be so, but such is not my opinion. The cases in which necrosis is proved to exist resemble so closely in their general course and symptoms those in which recovery occurs, that I cannot doubt that the difference is one only of degree. In one the dead bone is so large, and the integrity of the end of the bone so much interfered with, that amputation becomes necessary; in the other the destruction is so slight that with the escape of a few drops of pus and disintegration of a mere crumb of dead cancellous tissue the primary disease comes to an end."

It is evident that in the early recognition and prompt treatment of acute epiphysitis in infants lies the secret of success in cutting short the disease and saving both life and limb. Restricted motion in a limb of an infant should always excite grave suspicion, and, if accompanied by fixation, is almost positive proof of articular trouble or of disease in close proximity to the joint. When swelling is present, the disease has advanced, the joint is in all probability involved, and we have to do with a purulent articular disease. The treatment of acute epiphysitis in infants must be prompt, no matter how young the patient may be. Absolute rest must be enforced by means of splints, and, if we are satisfied that pus exists in the joint, free incisions should at once be made, the cavity disinfected, a drainage-tube inserted, and the joint fixed and dressed antiseptically: the earlier this is done the better are the chances of saving the joint. The course of the disease in many cases is so rapid that delay of even a day in affording an exit for the pus may jeopardize the articulation. The relief thus afforded is

frequently followed by rapid improvement in all symptoms, and, although the swelling may be great and the local and constitutional symptoms marked, recovery will take place with a normal joint. The peculiarity of these affections consists in their acute course and their prompt response to proper treatment. If there is much swelling of the limb above or below the joint, it is probable that pus is burrowing either among the muscles or beneath the periosteum. In such cases incisions should be made, so as to afford exit for the matter. Where the disease pursues a much more chronic course, incisions may be put off longer. The integrity of the joint, even in the most acute cases, is often preserved with normal motion.

---

## SHOULDER - JOINT.

The shoulder-joint resembles in some respects the hip-joint : it is a ball-and-socket joint ; it is attached to a comparatively short bone, the scapula ; the humerus forms the long arm of a powerful lever when the scapula is fixed ; but the articulation is not called upon to sustain any weight, as is the hip-joint, and thus intra-articular pressure is not so marked when the patient is up, and when the arm hangs down by the side. The epiphysis is within the cavity of the joint, so that any disease of that portion of the bone is almost sure to involve the articulation.

The joint may be the seat of acute or of chronic trouble. The disease may begin in the synovial membrane or in the bone.

### SYNOVITIS.

Acute synovitis is rare in children, and, when it does exist, is due to traumatism or cold. Its symptoms are stiffness, pain, swelling, and heat. Restricted motion is an early symptom, and is soon followed by pain and swelling. The pain is either confined to the joint or is referred to the middle of the arm above the insertion of the deltoid. In acute troubles it is usually severe. The swelling gives the shoulder a rounded or globular appearance. The deltoid seems much fuller than that on the sound joint. Pain is increased by any movement of the arm or by pressing the articular ends of the bone together. The parts are hotter than normal, and fluctuation can often be detected in the joint. The arm is held by the side of the chest, that being the most comfortable position. In moving the arm the scapula is found to move with it.

The treatment of acute synovitis consists in rest and cold applications. The arm is fixed to the chest by means of a bandage, the elbow being flexed and supported on the chest : a splint moulded so as to fit over the shoulder, and securely fastened by bandages to the chest, is useful. A simple synovitis seldom becomes purulent.

Purulent synovitis is usually due to a wound, or comes on in the course

of scarlet fever. Its symptoms are simply those of acute serous synovitis intensified, with the addition of redness or œdema about the joint. It may begin with a chill, and is accompanied by a much higher temperature than the simple form of the disease. When it comes on in the course of scarlet fever or any of the eruptive diseases, it is a serious condition.

Treatment of purulent synovitis of the shoulder differs in no respect from that of the same affection in other articulations. The joint must be opened, disinfected, and drained. Marsh considers that in this condition supervening on scarlet fever the indications are to let it alone unless the destruction is marked.

#### TUBERCULAR DISEASE.

Tubercular disease of the shoulder is sometimes met with in children, and, like all affections of this nature, it is slow and insidious in its development. It may begin in the synovial membrane or in the bone. Marsh states that it usually begins in the synovial membrane, but in the few cases that have been under my notice it has started in the bone. Its pathology is the same as that of tubercular affections of other articulations.

The symptoms of disease beginning in the synovial membrane are stiffness, swelling, pain, and restricted motion. Restricted motion is an early symptom, but care is required in order to detect it. It must be remembered that, even if the shoulder-joint is fixed, the arm may be movable over almost its normal range of motion, on account of the loose attachment of the scapula to the back, the arm and the scapula moving together. Hence, when testing the amount of restricted motion at the shoulder-joint, the scapula should always be fixed with the hand. Pain is variable, as in strumous disease of other joints. When it is present it may be in the articulation itself or at the insertion of the deltoid in the humerus. Atrophy is always a prominent symptom. The deltoid is more or less wasted, as well as the scapular muscle, and this is an important symptom. The arm hangs down by the side of the chest if there is much pain; otherwise the patient apparently moves it, but on examination it is found that the motion is in the scapula. When disease begins in the bone, vague pains are often complained of, usually at night, and the joint is a longer time in showing symptoms of disease. After it has become involved its appearance will be that of disease beginning in the synovial membrane. In osteitis of the head of the humerus there will be considerable atrophy of the muscles before any marked swelling in the joint can be detected. Abscesses usually form in the joint; the pus may escape by the side of the long tendon of the biceps. They are said to be less liable to form in disease beginning in the synovial membrane.

The treatment of disease beginning in the bone is rest, the same as that of the synovial variety of the disease. If the joint becomes involved and pus forms, it should be evacuated, the joint washed out, and good drainage afforded. In cases beginning in the bone the epiphysis is often detached and

lies loose in the joint-cavity. In such a case it should be removed. Often the centre of the end of the bone will be destroyed, its shell being left. In case of caries of the head an operation of any magnitude is not required, nor any extensive gouging, a free exit for matter being all that is, as a rule, called for. If, however, a regular excision is demanded, the muscles about the joint should be interfered with as little as possible, and great care taken that the deltoid is preserved, as there is always great danger of dividing some of the branches of the circumflex nerve and thus paralyzing that muscle. MacCormac speaks well of the subperiosteal method of operation when the disease does not involve too much bone.

Three incisions have been used,—namely, an incision down through the middle of the deltoid, an anterior, and a posterior. That through the deltoid is always followed by paralysis of that muscle, on account of the necessary division of the circumflex nerve or some of its important branches. The anterior incision is shown in Fig. 26; and here also the integrity of the

FIG. 26.

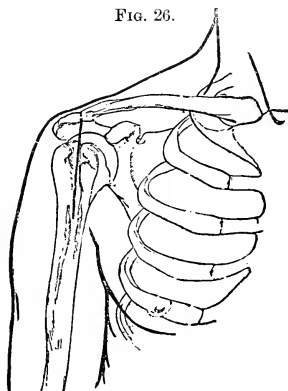

Method of resection by a single straight anterior incision. (MacCormac.)

FIG. 27.

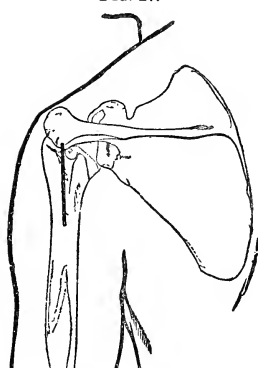

Position of the posterior incision made for resection of the shoulder. (MacCormac.)

deltoid is interfered with almost as much as by the central one. Maisonneuve proposed that the incision should be made downward from the external margin of the coracoid process or in the interval between the deltoid and pectoralis major muscles, the vessels and nerves being in such a case pushed considerably inward (MacCormac). The posterior incision (Fig. 27) requires a cut about three inches long. In this operation the circumflex nerve will be divided, and no abduction of the arm can be expected.

Thus it is seen that radical operations upon the shoulder-joint are beset with dangers in regard to the future use of the arm; and this is the chief reason why excisions of this joint are so unpopular and followed by such unsatisfactory results. In removing diseased bone from the shoulder-joint the operation should be confined to the parts within the capsule as much as



possible. If more bone has to be removed than can be reached from within the joint, the periosteum should be stripped off the shaft from above downward, care being taken to preserve as far as possible the attachment of the capsule and muscles to this membrane. After the bone has been removed, a cylinder of periosteum remains connected with the capsule and the attachment of the capsular muscles. The advantage of this method of operating is that it increases the probabilities of a good articulation, and that the muscles are not so liable to retract and draw the cut end of the bone inward to a position beneath the coracoid process, as is apt to be the case in other methods of operating. (MacCormac.)

Excisions of the shoulder-joint have not, up to the present time, been followed with very flattering success, although in a few cases a certain degree of useful motion has been attained.

In the after-treatment massage and electricity should be used, to keep the muscles from becoming more atrophic.

---

## ELBOW-JOINT.

The elbow-joint is in children liable to disease of both an acute and a chronic nature. Inflammation may be caused by a fall, a blow, or a wrench. This would naturally be expected from the exposed position and constant use of the articulation. Fractures into it are frequently the starting-point of strumous disease in those who by inheritance or otherwise are of low vital powers.

### ACUTE INFLAMMATION.

Acute inflammation may be due to any of the above-mentioned causes. Its symptoms are restricted motion, swelling, pain, heat, and muscular wasting. Swelling is an early and constant symptom, first noticed on the outer side about the head of the radius and the end of the olecranon, giving to the joint the appearance from behind of being wider than normal; the depressions are also obliterated, especially those on either side of the biceps; later the whole joint is enlarged. When the elbow is the seat of disease, the forearm is held at an angle of about one hundred and thirty or one hundred and forty degrees with the arm; the joint is also fusiform in shape. Active motion at the articulation is early lost if the disease is at all acute. The joint cannot be fully extended. Sometimes rotation is interfered with; at other times it is not much, if at all, restricted. Pain in acute troubles is marked, and the least movement increases the suffering; while in subacute chronic cases it may be entirely absent. The temperature of the parts in acute disease is greatly raised; in mild cases its rise is slight, and in chronic cases scarcely perceptible. Muscular wasting is often marked, and in strumous affections the muscles are greatly reduced in size. Marsh states that "the absence of muscular wasting in cases of sus-

pected disease of the elbow may be taken as strongly suggesting that the joint is not itself affected." An elbow-joint that has been the seat of disease, more especially tubercular disease, presents a very characteristic appearance: the muscles of the arm and forearm are greatly wasted, while the elbow is puffed out and of a fusiform shape.

The treatment of all diseases of the elbow-joint of an inflammatory nature consists in keeping the parts at absolute rest. This is best accomplished by the use of right-angled felt splints moulded to the arm and forearm (as in Fig. 28) and by carrying the arm in a sling. The splints should be removed every day or so, and the parts bathed, so as to keep the skin healthy.

If the disease is very acute or there is much pain, the patient should be confined to the bed, with the parts resting upon a pillow. Instead of a felt or leather splint, plaster-of-Paris may be used, but it is not so comfortable as a well-fitting felt splint. Some surgeons advocate the use of leeches, but, as said before, they frighten children. The use of an ice-bag or of cooling applications affords comfort. Our main reliance, however, must be upon absolute rest, the joint being kept fixed until long after all symptoms of disease have passed away. If pus forms within the joint during any acute inflammation, its symptoms will be increased swelling, pain, and constitutional disturbance. There may be œdema of the parts and frequent rigors, depending upon the degree of inflammatory action. With these indications the joint should be examined by means of a hypodermic needle rendered aseptic, and, if pus is found, the articulation must at once be opened, washed out, and drained. Even if suppuration has taken place, the patient may recover with a normal joint if action is prompt.

FIG. 28.

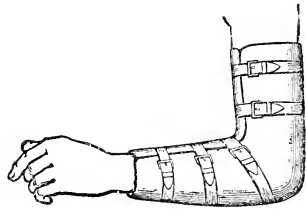

Splint for the elbow. (Marsh.)

#### TUBERCULAR DISEASE.

Tubercular disease of the articulation is quite common, and is often very slow in its development. The child may use the limb although the joint may be considerably swollen and pus present in the articulation, but he moves it over a small arc. Disease may begin in the synovial membrane or the bone. In the former case the swelling comes on early; in the latter case stiffness, pain, and muscular atrophy may be present some time before there is much tumefaction of the joint. Even when the articulation is extensively diseased, the child may have considerable use of the arm and may be able to extend and flex it over a greater or smaller arc.

The treatment of tubercular disease of the elbow is rest by means of an angular splint. This should be applied as soon as the trouble is detected. By this means we can often obtain a cure, with motion, even when the disease has made considerable progress. It is often astonishing how much can

be accomplished by rest in these cases. An elbow-joint should always be put up at a right angle, for if ankylosis should take place this position is the most useful one.

When the bones are much involved and abscesses have formed in the joint and it is disorganized, a movable articulation is not to be looked for, and excision will afford not only a useful but also a movable joint. An operation is called for when the bones are much diseased, or in synovial affection after the joint has become disorganized and when chronic suppuration is present, or when the joint is ankylosed at an unfavorable angle.

In excision of the elbow a movable articulation is looked for. The operation is not a formidable one, and, if properly performed, the result is good in regard to the usefulness of the limb. In excising the joint certain precautions must be taken. MacCormac advises that "the external lateral



FIG. 29.  
Line of incision in excision of elbow. (MacCormac.)

ligaments must be preserved if possible, in order to give stability to the joint and to preserve its connection with the orbicular ligaments of the radius, for when these are preserved the future usefulness of the limb is materially enhanced." A long median excision is the best (Fig. 29). A T-shaped one is not only not necessary, but also divides the tissues uselessly. This longitudinal cut should be three or four inches long, made in the median line on the back of the joint, and should divide all structures down to the bone, care being taken that it does not incline too much towards the internal condyle, as in such a case there is danger of injuring the ulnar nerve. All the soft parts are then separated from the bone with a periosteal elevator; the internal flap contains the ulnar nerve, which is but seldom seen; both condyles are thus cleared of all tissue. Marsh states that when the nerve is divided it is done below the joint by cutting among the muscles of the forearm; if, however, the incision is made down upon the posterior border of the ulna, there can be no danger of such an accident. The centre of the excision should correspond to the joint. The triceps tendon is split longitudinally and the capsule opened. The tendon of the triceps is then separated from the end of the olecranon, and thus the interior of the joint is fully exposed. Another important precaution to take is to preserve the anconeus muscle, as this is the only connection between the triceps and the ulna. This muscle after its future development aids as an extensor of the forearm. After freeing all muscles with as little injury to them as possible, the olecranon is removed with cutting pliers; the condyles of the humerus are then detached and removed. The old method of forcing the ends of the bones out through the incision is not an advantage, as the soft parts are more liable to injury than when the bones are divided *in situ*. After the wound has closed firmly, the angle at which the parts have been placed should be changed every few days, and as soon as possible the patient should be allowed to be up with the arm in a sling, and passive motion practised daily.

Partial excisions of the joint have been performed, but usually for injury. Some operators, however, always try to preserve the end of the olecranon.

Pickering<sup>1</sup> performed the operation in the following manner. The joint was exposed in the usual way with a long median incision; the tip of the olecranon was then divided with a chisel and reflected upward. After the removal of the ends of the bone, the tip of the olecranon was united to the ulna by means of a strong wire suture. He reports a fair result at the end of three months. The power of extension was better than that of flexion. This is always the case. The chief defect after excision of the elbow-joint is the often extremely weak power of flexion.

The subperiosteal method of operating is advocated by some surgeons. It is claimed that by this method the joint is more shapely and strong. After the operation the bones must be kept in closer contact, in order that the development of new bone may be greater and thus a larger joint-surface be secured. Passive motion must also be begun earlier, in order to mould the parts better and to prevent ankylosis.

After excision of the elbow-joint the danger is that ankylosis will take place, especially if not enough bone has been removed; on the other hand, the result may be a flail joint in which there is little power of either flexion or extension. To prevent the former, early passive motion should be resorted to. By early is meant as soon as the wound has closed, provided always that it does not irritate the soft parts and cause them to be inflamed, and that it does not cause any discomfort to the patient. The movement must at first be over a small arc, gradually increased daily, and as soon as the patient can execute any active movement he should be encouraged to do so. A splint should not be worn too long.

The best way to guard against a flail joint is to remove plenty of bone, and not resort too early to passive motion. In case a weak joint should result, the bones may be again divided and put in apposition, in order to obtain ankylosis. Care should also be taken that the bones are put at a right angle, as that is the most useful position.

Sometimes there remains a lateral movement at the new articulation. To prevent this, Gerster advocates the use of a simple application as soon as

FIG. 30.

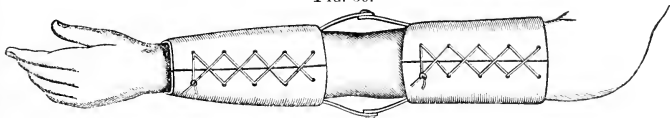

Apparatus for after-treatment of excision of elbow-joint. (Gerster.)

it is evident that there is a defect in this direction. As shown in Figs. 30 and 31, it is constructed in the following manner. "Two strips of hoop-iron or sheet zinc, about one inch wide and from four to six inches long, are

<sup>1</sup> Lancet, October 2, 1886, p. 628.

loosely riveted to each other at their ends, so as to form a hinge. Two pairs of hinges are necessary. The patient's arm being protected by a few turns of a flannel bandage, a light silicate-of-sodium wristlet and arm-band (Fig. 30) are applied. To these are fitted the hinges, one externally and the other internally, by giving their middle a suitable bend to allow for the expansion of the soft tissues on flexion of the joint. By a few more turns of the silicate bandage the hinges will become immured in the wristlet and arm-band. As soon as the splint is dry, it is split longitudinally on its anterior aspect, to permit of its removal and further fitting. Shoe-eyelets are put in along the edges of the longitudinal cuts, for lacing. Two pairs of small-sized brass screw-eyes are let in on each side of the wristlet and arm-band, to serve for the attachment of solid rubber bands, which are to aid the effort of the flexor muscles in bending the elbow. To prevent slipping down of the apparatus, a cap is made of a piece of sole-leather softened in hot water, which is moulded to the shoulder. It is then left to dry. A button is let in it to serve for suspending from it the apparatus by a short strap. Another strap over this button is passed around the thorax of the patient and is buckled in the opposite axilla."

FIG. 31.

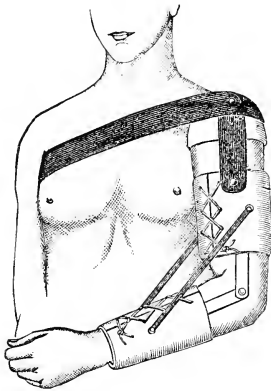

Splint applied. (Gerster.)

Always after operations upon this joint, extension is more powerful than flexion. Sometimes the latter is so weak that the arm is almost useless. This weakness may result from a lack of support in the cut ends of the bone, due to their small size, which allows one bone to slip over the other; or it may be owing to want of power in the flexor muscles. But, whatever causes it, a firm union between the bone at a right angle will give a much more useful limb.

The after-treatment of the limb consists in strengthening the weak muscles by exercise, massage, and electricity.

## ANKLE-JOINT.

Disease of the ankle-joint is common among children, and is due to the same cause as disease of other articulations. The affection may be acute, subacute, or chronic, and of a tubercular or non-tubercular nature, but the former is the more common. It may start in the bones or in the synovial membrane. The ankle-joint is more frequently the seat of injury than any other joint in the body. Notwithstanding this fact, it is not affected with

disease so frequently as might be supposed. In children predisposed to tubercular affection, any slight traumatism may be the starting-point of serious disease.

The diagnosis of disease of the ankle is not easy, on account of the proximity of the tarsal bones and joint. Mr. Marsh makes the statement that he has "witnessed more than one instance in which Syme's amputation has been performed under the belief that the joint was disorganized, but in which it has proved that the disease was situated entirely in some surrounding parts."

Disease may begin in the bones or the synovial membrane. It may begin in the tibia, the astragalus, the os calcis, or any of the other bones, the joint being secondarily involved; while, on the other hand, the tarsal bones may be diseased without affecting the ankle-joint, and in making up a diagnosis this fact must be kept in mind, otherwise an error may be made. The presence of a sinus near the ankle-joint is of little practical importance unless a probe can be passed into the joint itself. When abscesses have formed and the parts are swollen, it is very difficult to say whether the ankle-joint is involved or not. When tubercular deposit has taken place in either the end of the tibia or the body of the astragalus, there will be at first slight pain in the parts, with tenderness on pressure; there will be lameness at first only after exercise, with perhaps some stiffness of the joint in the morning, and later occasional effusion into the articulation, disappearing after rest, but finally the joint will become permanently enlarged and lameness will be persistent. Swelling in synovitis of the ankle-joint is easily detected, and is characteristic. There will be swelling in front, where it obliterates all the natural depressions and hides the course of the extensor tendons, at the sides about the malleoli, and at the back, where it fills up the normal depressions on each side of the tendo Achillis. Swelling in the latter position is always present when the joint is distended, and is usually more marked than in any other location: its absence in this locality should raise a doubt as to the joint's being involved.

In tubercular synovitis there may be but little pain; the child will walk with a limp, the foot being held stiff in order to prevent motion in the joint, yet he will not complain of pain. On examination there is often found free and painless motion over the middle range of movement, and it is only when these points are passed that pain will be complained of. As the disease advances the pain will increase and the limp be more marked; the child will not put his foot to the ground, but will go about with a crutch. When the swelling is marked the skin has often a marbled appearance. There is atrophy of the muscles of the leg. The temperature of the parts is variable; sometimes the ankle will feel colder than that of the sound limb. What chiefly attracts attention is the roundness of the parts: all normal depressions are obliterated, and the whole ankle presents a puffed-out appearance. Finally abscess forms and opens.

Disease beginning in the bone has a different history. The pain comes

on long before the swelling, and is at first irregular in its character, as is osteitis of the articular ends of other bones; but the lameness is more marked.

The differential diagnosis of disease of the ankle-joint is often puzzling: it may be confounded with extra-articular abscess, with disease of the astragalus, or with inflammation of the sheath of the extensor tendons.

In disease of the astragalus, the scaphoid, or the cuboid bones the swelling is liable to be most marked in front of the ankle-joint, and there is an absence of the obliteration of the depressions at the side of the tendo Achillis. Extra-articular abscesses give still further trouble, because they may surround the ankle-joint; but their history is more acute than that of disease of the joint itself, the pus seems more superficial, and the swelling is liable to extend more forward upon the foot under or along the course of the extensor tendons; further, though at some parts swelling may seem to involve the joint, in other parts the joint preserves its natural outline. The swelling may be well marked in front and on the outer side, but absent from the inner part of the joint (Marsh). A sinus over the joint affords no proof that the articulation is the point of disease; it may be connected with trouble in any other of the tarsal bones, far away from the ankle-joint.

In disease of the sheath of the tendons the swelling is in front and takes an antero-posterior direction, while in disease of the joint the long axis of the swelling is transverse.

Treatment of disease of the ankle-joint, whether it begins in the bone or in the synovial membrane, is the same, and consists in applying a splint or a plaster-of-Paris bandage to the foot and leg and keeping the child from putting the foot to the ground. In fixing the joint, care must be taken that the foot is placed at a right angle to the long axis of the leg, for if ankylosis takes place with the foot either slightly flexed or extended there will be difficulty in walking. With the foot in an extended position the patient will walk with great insecurity, and often with pain; while with it in a flexed position the heel alone comes to the ground. Treatment should be kept up until all signs of disease have long ceased. If the joint becomes disorganized and an abscess forms, it should be opened and the joint-cavity scraped and disinfected. If the bones are involved, the diseased portion can be easily removed.

A regular excision of the ankle-joint, as laid down in works upon surgery, is never called for. The articulation may be examined by making an incision just behind and parallel with the fibula to its lower extremity and thence forward over the front of the foot, the latter portion of the cut only dividing the skin; the external malleolus is then cut off and removed, and the ligaments and capsule are divided, so that the foot can be dislocated inward and its parts reached. If further room is required, the same operation can be done upon the inner side, and thus every portion and recess of the joint reached. I have found that with an osteotome a section can be readily taken from both the astragalus and the end of the tibia. It is, how-

ever, seldom necessary to remove a section from either bone, but with a Volkmann's spoon any diseased portion of bone can be taken away. After removing all that is necessary, the foot is put in an antiseptic dressing and fixed at a right angle in some kind of splint.

Operations upon the ankle-joint in childhood generally do well, a useful and movable joint is usually obtained, and there is little if any limp. In case the tendons have to be displaced, care should be taken to replace them and fix the shield by sutures before closing the wound. If the foot at the time of the operation or at any subsequent time should become extended, the tendo Achillis should be divided and the malposition corrected.<sup>1</sup>

---

<sup>1</sup> The writer, in preparing this article, has made very free use of Dr. Gibney's work on "Diseases of the Hip" and of Dr. Howard Marsh's treatise on "Diseases of the Joints."



# DISEASES OF MINOR ARTICULATIONS.

BY D. A. K. STEELE, M.D.

---

## INTRODUCTORY REMARKS.

IN considering the diseases and treatment of the minor articulations, reference will be made solely to those affections occurring in children that implicate the carpal, metacarpal, and phalangeal articulations of the upper extremity and the tarsal, metatarsal, and phalangeal articulations of the lower extremity.

So far as I am aware, there is no essential difference in the pathological processes that take place in the smaller joints of children that would serve to distinguish them from similar changes induced by like causes in adult joints, if we except the greater tendency to repair and the more rapid regeneration of injured tissues that are so uniformly observed in the average child patient. There is, however, the possibility of mistaking an epiphysial separation for a fracture or a dislocation.

We must also remember the risk of causing an epiphysial separation if undue force is used in breaking up adhesions in joints previously inflamed. Owen<sup>1</sup> states that stiffness in joints in childhood almost certainly works off in time, and Paget<sup>2</sup> adds the warning that "children's joints are much more imperilled by violence than those of older patients."

There is, of course, a greater field for the exercise of tact and finesse in the examination and treatment of the diseases and injuries to which their smaller joints are liable. We are not able to go directly at the injured member as we would in the adult, but must first gain the confidence of the little patients before they will permit any examination to be made. We must, if possible, put ourselves *en rapport* with them and be regarded as their friends, and study their unspoken language of signs and facial expressions, if we would patiently yet persistently get the ailments of their minor articulations at our fingers' ends.

Much information is gained by ocular inspection and comparison of the joint while listening to the history of the case from the mother or nurse of the child. Begin the examination indirectly by handling the opposite hand

---

<sup>1</sup> Surgical Diseases of Children, 1885, p. 389.

<sup>2</sup> Clinical Lectures and Essays, p. 93.

or foot : teach the child by the gentleness of your manipulation of the sound toes or fingers that you are not going to inflict unnecessary pain, and you have gained a great point in the subsequent management and treatment of the case. The first examination should always be thorough, and made in a room with good light and every opportunity for a careful observation of the surface-markings. In case it is necessary to use an anæsthetic, chloroform should preferably be administered, on account of its comparative safety for children, its pleasant odor, and the rapidity with which narcosis can be induced when a few drops are placed on a small linen handkerchief and held closely over the nostrils of a rapidly-breathing child. During anæsthesia and operation the parents should be excluded from the room, as their presence only tends to distract the attention of the surgeon.

#### ANATOMICAL PECULIARITIES.

The bones are developed from the mesoblast, or middle layer of the blastoderm. "The wrist, or radio-carpal joint, is formed above by the lower end of the radius and the triangular meniscus, below by the upper articular surfaces of the scaphoid, semilunar, and cuneiform bones. An investing ligament, lined by a synovial membrane and subdivided into anterior, posterior, internal, and external bands of fibres, encloses the joint. It is the oblong form of hinge-joint, and possesses two axes, a long and a short. Around the long axis movements occur which bend the hand forward, or bring it in line with the forearm, or bend it backward. Around the short axis the hand may be moved towards the radial or ulnar margin of the forearm.

"The carpal and carpo-metacarpal joints are constructed thus : the articular surfaces are retained in contact by certain ligaments passing between the dorsal surfaces of adjacent bones, by others between their palmar surfaces, and by interosseous ligaments between the semilunar and cuneiform, semilunar and scaphoid, os magnum and unciform, os magnum and trapezoid ; lateral ligaments also attach the scaphoid to the trapezium, and the cuneiform to the unciform ; similarly the trapezoid, os magnum, and unciform are connected to the metacarpal bones of the fingers by dorsal, palmar, and interosseous ligaments, and the metacarpal bones of the fingers have a like mode of union at their carpal ends. Further a transverse ligament extends between the distal ends of the metacarpal bones of the fingers and checks too great lateral displacement. The range of movement at any one of these carpal joints is very slight, but the multiplicity of joints in this locality contributes to the mobility of the wrist, and makes the junction between the hand and forearm less rigid in its nature. The metacarpal bone of the thumb is not jointed to the index, and has a distinct saddle-shaped articulation with the trapezium, invested with a capsular ligament, so that its range of movement is extensive.

"The metacarpo-phalangeal and inter-phalangeal joints are connected

by lateral ligaments passing between the bones, and by an arrangement of fibres on their palmar and dorsal surfaces.

“The movements of the joints are indicated on the surface of the palm by tegumentary folds,—an oblique fold for the thumb and two oblique folds for the metacarpo-phalangeal joints of the fingers. The joints of the second and third phalanges are also marked on the surface by folds.

“The ankle-joint is formed by the convex upper and the lateral surfaces of the astragalus fitting into the concavity formed by the lower end of the tibia and the two malleoli. An investing ligament, lined by synovial membrane, encloses the joint; the lateral portions of this ligament form distinct bands, and are much stronger than the anterior and posterior fibres. A diarthrodial joint also exists between the astragalus and os calcis, between which bones a powerful interosseous ligament passes. Between the astragalus and scaphoid, and the os calcis and cuboid, important diarthrodial joints are found which are enclosed by ligamentous bands. The remaining tarsal bones are connected together usually by dorsal, plantar, and interosseous ligaments, and a similar mode of union is found between the distal row of tarsal bones and the metatarsals, except between the great toe and entocuneiform, where there is no interosseous ligament. The four outer metatarsals are also connected at their proximal ends by distal, plantar, and interosseous ligaments, and further a transverse metatarsal ligament passes between the distal ends of all the metatarsal bones. The metatarsal bones articulate with the phalanges, and the phalanges with each other, in a similar manner to that described in the corresponding bones of the hand. At the ankle-joint movements of flexion and extension take place. . . .

“Between the several bones of the tarsus a certain amount of gliding is permitted, more especially between the os calcis and cuboid and the astragalus and scaphoid, so that it is possible to invert or evert the foot,—*i.e.*, to raise the inner or outer borders from the ground. . . .

“The hallux, or great toe, is the most important digit. A line prolonged backward through it to the heel forms the proper axis of the foot, and the sole chiefly rests upon the pads of integument situated beneath its metatarso-phalangeal joint and the heel.”<sup>1</sup>

The epiphysial nucleus appears in the metacarpus and phalanges from the third to the fifth year, and the epiphysis unites in the twentieth year; while in the metatarsus and phalanges it appears from the third to the eighth year, and union occurs from the nineteenth to the twenty-first year.<sup>2</sup>

The four inner metacarpal and metatarsal bones have distal, the outer proximal epiphyses. All the phalanges have the epiphyses proximal. Thus, all the metacarpo-phalangeal joints, save that on the thumb, are on two epiphyses; and so at the foot all metatarso-phalangeal articulations are doubly epiphysial except the hallux.

<sup>1</sup> Creighton, *Encyclopædia Britannica*, ninth edition, 1878, vol. i. p. 839, art. “Anatomy.”

<sup>2</sup> Barwell, *Treatise on Diseases of the Joints*, 1881, p. 8.

## CLASSIFICATION OF DISEASES OF MINOR ARTICULATIONS.

In accordance with modern pathological views, the diseases of the smaller joints may be classified or divided as follows.

*Plastic Inflammations.*—Synovitis (simplex), syndesmitis, arthritis, osteo-arthritis, osteitis, teno-synovitis, ganglion.

*Chronic Infectious Inflammations.*—Tuberculosis, osteo-myelitis, rheumatism, gonorrhœa, syphilis, pyæmia, metastatic.

*Acute Infectious Inflammations (Sequelæ).*—Measles, scarlet fever, small-pox, typhus fever, typhoid fever, cerebro-spinal meningitis, pneumonia, dysentery, diphtheria, erysipelas, parotitis, pertussis.

*Tumors.*—Chondroma, sarcoma.

## PLASTIC INFLAMMATIONS.

As a result of contusions, sprains, or injuries of the minor articulations, we have a variety of simple inflammations that have a natural tendency to recovery if the injured joint is kept at rest. This, however, is not an easy matter in a child: hence the frequency with which we see these simple acute inflammations merge into the chronic forms of disease, the restless activity of the child preventing the necessary quietude of the joint, and the repeated jars and irritations of a damaged joint favoring the localization of infective microbes latent in the blood of the child, until the soil is properly prepared by blood-stasis and aggregation of leucocytes for the segregation and destructive multiplication of infective micro-organisms. In this way we so frequently trace the clinical history of joint-tuberculosis in children, and hence the necessity for prompt, early, and persistent treatment of the plastic or simple non-infectious joint-inflammations of childhood.

The relative strength of the different anatomical structures entering into the formation of the smaller joints of children predisposes to the greater frequency of sprains on the infliction of traumatism rather than to fracture or dislocation. The joint-formation is also favorable to overstretching of the ligamentous structures.

**SYNOVITIS.**—Simple synovitis involving the carpal, tarsal, or phalangeal articulations is most frequently due to a wrench or sprain, although it may result from exposure, from over-exertion, or from unknown causes. In few affections are the four classical Galenic symptoms of inflammation better exemplified than in an acute synovitis. Heat, pain, swelling, and redness are ordinarily complained of within a few hours after the joint has been injured. The effusion is rapid, and the increased amount of synovia is frequently tinged with blood from rupture of minute intra-articular capillary vessels. Loss of function and tenderness accompany the other symptoms.

**SYNDESMITIS.**—In syndesmitis, or inflammation of the ligaments about a joint, there is usually the history of a sprain followed by the ordinary symptoms of such injuries,—pain, tenderness, localized swelling (at first limited to one side of the joint, as a rule), ecchymosis, and immediate loss

of function. The pain is instantaneous in character. After a few days plastic crepitus may be noticed, due to peri-articular effusion.

**ARTHRITIS.**—A simple arthritic inflammation may be caused by injury or exposure, or by an extension of a contiguous inflammation, and gives rise to symptoms closely allied to those described as accompanying synovitis.

**OSTEO-ARTHRITIS.**—An osteo-arthritis or osteitis is generally caused by a concussion or contusion of the joint and a bruising or laceration of minute blood-vessels or capillary loops at or in the articular extremity of the bone, followed by hyperæmia, stasis, thrombosis or minute emboli, and a localized inflammation that has a distinct tendency to extend to the adjacent joint-surface if absolute rest is not enjoined. The pain is deeper seated, more aching in character, subject to exacerbations, and sometimes the little patient complains only of the joint "feeling tired." There is not much swelling at first, rarely is ecchymosis present, and there is but partial suspension of joint-function.

**TENO-SYNOVITIS.**—Teno-synovitis is most frequently developed along the sheaths of the flexor tendons of the wrist, although also observed in the extensor sheaths of the same joint as well as around the tendons of the ankle, and is caused by a sudden sprain from a blow or over-lifting or from over-exercise at an unusual or unaccustomed kind of work.

The symptoms complained of are pain, tenderness, and swelling along a tendon-sheath, the pain being increased by movements of the tendon. There is an evident disability of the member at first, but after a few days this is less marked. On palpation, a fine tendinous crepitus, soft and rustling in quality, can be elicited. Congestion, followed by serous and later by fibrinous exudate, marks the pathological changes that are present. The affection usually lasts from one to three weeks.

**GANGLION.**—Upon the back of the wrist we sometimes find ganglia, either cystic, articular, or merely, and far more commonly, hernial pouches or protrusions through the tendon-sheath at some weak point that has yielded in consequence of a sprain. They are, as a rule, of slow growth, painless, and we are consulted about them more frequently on account of their unsightliness than anything else, although sometimes they cause an appreciable weakness of the wrist and become painful after manual labor. The contents are viscid and albuminous.

The proper treatment of ganglion in the early stage consists of firm elastic pressure by a pad and bandage, and, if this proves inefficient, then subcutaneous puncture with antiseptic precautions, and expression of the contents, with subsequent compression. If refilling occurs, excision of the hernial sac of the tendon-sheath, with strict attention to Listerism, secures a permanent cure. The edges of the sheath should be closed by a fine catgut suture, the external wound closed with silk, and the wrist immobilized for several days. The tubercle-bacillus has a tendency to infect these hernial sacs of tendon-sheaths.

For clinical purposes, all these affections known as plastic or non-

infectious inflammations of the smaller joints might be united in one group and described as sprains of more or less severity, involving one or all of the component parts of a joint, according to the severity of the traumatism applied. In the consideration of their treatment we will regard them as so grouped.

**Treatment.**—The indications for treatment are, clearly, to secure rest, relieve pain, subdue inflammation, and restore the functions of the joint. Complete physiological rest of an injured or inflamed joint is of prime importance. This may be secured in the smaller joints most readily by the application of a moulded, nicely-padded splint, applied so as to include also the proximal joint. In the case of the ankle- or wrist-joint, immobilization is attained by applying a light plaster-of-Paris cast. In all cases smooth, elastic, firm pressure should be obtained by surrounding the joint with layers of cotton batting or absorbent cotton under the fixation dressing. If wounds, abrasions, or blisters are present on the skin, they should be first well cleansed, disinfected, dusted with iodoform, and covered with a layer of antiseptic gauze. When immobilization of the joints of the fingers, hand, and wrist is secured, the forearm should be carried in a sling.

In acute inflammation of the ankle or tarsal joints, after immobilization the patient should remain in bed for some days, or at least keep the foot elevated, and afterwards use crutches until repair is complete.

In the phalangeal joints of the toes and metatarsal joints, immobilization may be secured by wearing a Chinese shoe or a shoe with a Thomas sole or a broad unbending sole, care being taken that it is long enough not to press upon the toes.<sup>1</sup> This, however, is more useful in the chronic inflammations of the joints.

Pain may be relieved by the application of firm elastic compresses, a layer of soft cotton, and over this a flannel bandage or pure rubber bandage drawn with just sufficient tightness to give a feeling of support. Hot fomentations, hop-bags, hot salt, and various anodyne solutions are of advantage, and give comfort to the patient.

Children almost always want “something put on it that will stop the pain.” I have found great relief from the use of the following formula in all contusions and injuries around the joints :

R Acidi carbolicī, ℥ ii ;  
 Glycerini, ℥ vi ;  
 Tinct. opii, f ℥ vii ;  
 Tinct. arnicæ, f ℥ iiss ;  
 Spts. vini rect. dil., q. s. ad f ℥ viii.  
 Apply freely to the injured part.

The internal use of sedatives is also often required if the pain is severe.

Inflammation is lessened by the elevation of the joint, by its fixation, and

<sup>1</sup> E. H. Bradford, R. W. Lovett Buck's Reference Hand-Book of the Medical Sciences, 1889, vol. viii. p. 368, art. “Joints.”

by the use of compression, hot fomentations, ice-bags, and such other measures as will tend to relieve arterial tension. When there is marked effusion within a joint, aseptic aspiration, with subsequent elastic compression, should be resorted to. It is advised by Martin to apply a rubber bandage around the joint and aspirate between the folds of the bandage, and after the withdrawal of the fluid to allow the bandage to remain on. This is excellent practice, and gives admirable results, especially in the knee.

The functions of the joint can be restored by passive motions, friction, embrocations, and especially by systematic massage, which stimulates the adjacent lymphatics to carry away the excess of plastic deposit around the joint that is often the cause of the stiffness. If there is a considerable amount of ankylosis, it is better to anaesthetize the child and completely break up adhesions rather than run the risk of causing additional joint-trouble by repeated inefficient attempts to overcome them. Gamgee advises soft dry sponges applied firmly around an inflamed joint, and then by wetting them efficient firm pressure is obtained that favors the absorption of effused products. Firm continuous pressure favors absorption and atrophy. Intermittent pressure stimulates new growth and plastic exudate. Children regain the usefulness of an inflamed joint in a remarkable manner, and I have been agreeably surprised, in a number of cases where passive motion had to be discontinued on account of pain or the dread of the child to have the joint moved, to find, after a judicious selection of toys or games which would necessarily bring into use the offending joint, that in the course of a few weeks or months the child had "worked off the stiffness," as Owen expresses it.

In teno-synovitis, or thecitis, firm elastic compression along the course of the inflamed tendon-sheath should be applied and secured by a flannel roller. The forearm should be laid upon one of Levis's metallic splints after the compress is applied, or a light plaster-of-Paris cast may be put on, or the forearm may be laid on a padded basswood splint and carried in a sling for a week or two. The disability rarely lasts longer than three weeks.

#### CHRONIC INFECTIOUS INFLAMMATIONS.

**TUBERCULOSIS.**—Tuberculosis of the minor articulations usually occurs as a primary osteitis or osteo-arthritis, more rarely as a synovitis. Although generally mentioned as a primary tuberculosis, it is, strictly speaking, a secondary invasion, as the primary *dépôt* must be situated in some of the lymph-channels before the bacillus reaches bones or joints. The mode of entrance, or "port of entry," of the tubercle-bacillus to the human organism may be either directly through a wound or abrasion, or through a lesion of the mucous membrane of the bronchial tubes, alimentary tract, or uro-genital system. In children invasion takes place most frequently *via* the lungs. No matter what the mode of entrance, we find forty per cent. of the cases occurring as a localized osteo-arthritis.

Tuberculous joint-disease is pre-eminently a disease of childhood. Boys are affected more frequently than girls.

**Localization of Tuberculosis.**—According to Schmallfuss's statistics relative to the frequency of localization of tuberculosis in the different bones or joints, we find that the foot is affected in nineteen per cent. of the cases, and the hand in eight per cent. only.<sup>1</sup> When we consider that children are peculiarly liable to the sprains and twists and various local minor articular traumatism that initiate the localization of tubercular processes, we can readily appreciate the importance of this subject and the necessity for its early recognition and proper treatment. Müller has demonstrated that when the bacilli of tuberculosis are present in the blood-current localization takes place frequently in young persons near the epiphysial cartilage by the microbes becoming arrested in one of the terminal branches of an artery, causing an obliteration of its lumen by an embolus of granulation-tissue containing bacilli; or the bacilli may be implanted upon the vessel-wall, and a gradually-increasing mural thrombus obstructs the lumen of the vessel.<sup>2</sup>

The peculiarity of the tubercle-bacilli is to incorporate themselves with a white blood-corpuscle and transform it into a lymphoid cell of larger size.<sup>3</sup> Obstruction of the lumen of an artery in the epiphysis of a long bone leads to the frequently-observed sequestration of a triangular piece of bone corresponding in shape to the area supplied by the vessel. Obstruction of the nutrient artery in the phalanges may lead to death of the entire shaft, especially if the pus-microbe invades the subperiosteal tissue.

**Diagnosis.**—Generally there is not much difficulty in arriving at a correct diagnosis of tuberculosis of a minor articulation when we take into account the history of the case,—slight traumatism, a neglected sprain or contusion, a subsidence of the acute pain and swelling, followed by a chronic thickening of the joint-structures, and a painless swelling of the joint or near the joint (painless unless overflexion or extension or deep firm pressure is made, which causes pain to be felt). There is an increasing weakness of the joint, extending to the proximal muscles also, which soon become atrophied from disuse.

In case of involvement of the wrist, the fingers are usually kept extended, and there is a marked helplessness about the member; fluctuation is indistinct, and sometimes "boggy" by reason of the mass of granulation-tissue in which coagulation-necrosis has not yet occurred. If the affection originates in the synovial membrane, the effusion and swelling are more marked. There is not much impairment of general health unless the lungs are the seat of miliary tubercles. There is not much tendency to ankylosis. Fibrinous flocculi, or rice-bodies, are indications of tuberculosis.

<sup>1</sup> Fenger, *Journal of the American Medical Association*, 1889, vol. xiii. p. 587, art. "Tuberculosis of Bones and Joints."

<sup>2</sup> Senn, *Surgical Bacteriology*, 1889, p. 185.

<sup>3</sup> Gerster, *Aseptic and Antiseptic Surgery*, 1888, p. 264.



In the ankle-joint the fungous synovitis with painless abscesses and fistulous tracks, through the mouths of which granulation-tissue protrudes, is the variety most frequently seen.

In the phalanges of the fingers and toes we meet with the central myeloid tuberculosis, or "spina ventosa" of some authors, expanding the compact structure of the bone to a mere shell, and frequently implicating multiple phalanges, with a tendency to epiphysial and articular involvement. This tuberculous osteo-myelitis also affects the metacarpal and metatarsal bones in children.

Weeping sinews or ganglion, communicating with the wrist-joint or existing in the sheaths of the extensor tendons overlying it, are now recognized as a form of tubercular infection of the synovial order, where we have the localization of the floating bacilli in the membrane by capillary embolism or mural implantation.

Tendon-tuberculosis is an appendix of joint-tuberculosis, and merits the same consideration.

**Prognosis.**—The prognosis in a case of local articular or osseous tuberculosis in a small joint is usually good, especially in children, provided there are no foci in the lungs. There is a natural resistance on the part of the child to disease-processes, a constant antagonism between growth and normal healthy tissue-development on the one hand, and degenerative changes due to the activity of the tubercle on the other, with the fortunes of war pretty constantly on the side of the physiological cell-soldiers. Hence the frequent recoveries from joint-tuberculosis in children, with, to be sure, occasional relapses, but generally a recovery with a lasting memento of the fight in some scars or a somewhat impaired joint that was the scene of the conflict.

**Treatment.**—Conservatism should be practised in all operations upon the joints of children: erosions, rather than excisions, should be the rule. The underlying principle of treatment in all simple inflammations of joints is rest—physiological rest—until the pathological changes are arrested. The principle of treatment of infective joint-affections should be to minimize the activity of the microbe that is the causal factor of the pathological processes under discussion, and to multiply the tissue-resistance of the child against the ravages of the micro-organisms of disease.

The organism minimizes the activity of the bacilli sometimes in cases where the destructive processes originate in bone near an articular surface; when perforation of the joint takes place, a wall of granulation-tissue is thrown across the joint around the seat of infection, and, if the circumstances are favorable, a wall of cicatricial connective tissue is formed which protects the intact from the infected portion of the joint, and resists the advance of the bacilli, which thus become walled in by their own environment and die a natural death. Of course where such a favorable termination takes place it is probable that the tubercular virus was attenuated by age or suffered from want of a proper nutrient medium. We fortify the

resistance of the child's organism by rest, diet, stimulants, and local refrigeration or pressure.

*Operative Treatment.*—Artificial anæmia of the limb by means of a rubber bandage should precede the operation, the bandage being applied above the affected joint only. In all operations upon tubercular joints strict attention to the details of antiseptic surgery is essential to success: sterilized hands, instruments, and field of operation are most desirable. Because of the opening up of venous channels in tubercular tissue, we are liable to subject the patient to the risks of dissemination of tubercle through the opened blood-channels, if care is not taken to remove thoroughly all infected tissue by knife, scissors, sharp spoon, or Paquelin cautery; moreover, if antiseptic precautions are neglected, pus-microbes are brought in contact with a surface well prepared by previous pathological processes for the development and propagation of suppurative and septic processes that imperil the integrity of the joint or may destroy the patient. Where the wrist-joint is involved, and especially if suppuration has resulted by reason of the invasion of the tubercular tissue by the pus-microbe, the infected joint should be thoroughly disinfected by irrigation with a sublimate solution, one to two thousand, careful cleansing and disinfection of the cutaneous surface around the joint, enlargement of existing sinuses, or a free dorsal or lateral incision over the most prominent part of the distended capsule, followed by a thorough scraping and clipping away of all diseased tissue, infected capsule, and carious bone, then touching all oozing vessels, especially in bone, with Paquelin cautery. Perfect hæmostasis is desirable, but not always attainable. When the diseased tissue is all removed, the joint should be flushed with a fifty-per-cent. solution of compound tincture of iodine, lightly iodoformized, drained with a small perforated rubber drain or twisted bit of iodoformed gauze, closed by a continuous silk suture, complete antiseptic dressing applied, and then placed on a well-padded palmar splint, or, better, a light plaster-of-Paris cast applied, and then redressed every three to five days. Not infrequently a revision of the operation is necessary where some infected tissue has been left. Functional results are better than from excision.

In ankle-joint tuberculosis the astragalus is most frequently primarily infected, and in cases requiring operative interference no attention should be paid to the anatomical outlines of the joint with a view to limiting the operation to a single bone or capsule. Free lateral, slightly-curved incisions should be made that will permit free access to and thorough scraping and curetting of the diseased tubercular tissue. If an abscess has already opened on the instep, as is frequently the case when we are first consulted, the sinus should be enlarged and traced into the joint, thoroughly spooned out, and injected with tincture of iodine. Through-and-through drainage should be provided, and dressings applied and changed as suggested for the wrist-joint.

As a rule, the functional use of the joint is fairly good after these opera-

tions. Indeed, if they are done before the articulation becomes pus-infected, and the operative cavity is permitted to fill with a moist clot under perfect aseptic closure, a remarkably good result is attainable. There is always some liability to relapses, and often a necessity for an operation of revision. This should always be done when pale tubercular granulations protrude from drainage-openings, or when cicatrization is slow.

In tendon-tuberculosis, the not infrequent sequel of sprains, the sheath should be freely opened and every portion of it that is infected carefully removed, along with the gelatiniform tissue frequently surrounding it. The tendon itself should be scraped if it is covered with fine, pale, jelly-like granulations, and after the wound has been thoroughly irrigated with a mercuric solution the surrounding healthy muscular and connective tissue should be closed around it with a continuous fine catgut suture, and the integument closed with silk sutures without drainage, the idea being to permit a moist clot to form around the tendon, and, by subsequent careful passive motions of flexion and extension, commenced ten days after the operation, a new sheath is grooved out of or in the blood-clot, and the movements of the wrist or ankle tendons are restored. Better results are obtained upon the dorsal than upon the palmar surfaces. After operations of this kind, for the first week or ten days a firm elastic graduated compress, with immobilization after the application of the primary typical Lister dressing, should constitute the treatment.

A similar plan should be followed in the treatment of "weeping sinews," or localized infected dilatation of the tendon-sheath: all fibrinous flocculi or melon-seed bodies should be removed, and the sheath closed around the tendon after the removal of infected parts.

**OSTEO-MYELITIS.**—Tubercular osteo-myelitis of the phalanges, or "spina ventosa," sometimes subsides spontaneously, or is diminished by the alterative action of iodine locally; but its manifest tendency is to invade more tissue, to disseminate itself, to attack secondarily the periosteum, and to form indefinite abscesses. The safest rule in dealing with this rather rare form of osseous tuberculosis of the minor articulations is to make a free incision, and chisel and scrape away all infected tissue with very small, specially-selected instruments. Often an excision or an amputation is required; and the invariable rule is permanent deformity or distortion of the digit.

In the milder and earlier cases of osseous or osteo-arthritic tuberculosis of the minor articulations, where the child's organism is physiologically active and its general health good, and where the attack of the bacilli seems to be comparatively feeble, we should be justified in waiting for a reasonable time before advising operative interference, and relying upon complete rest of the affected joint, placing it upon a moulded, well-padded splint, with moderate elastic uniform compression, for a sufficient length of time to enable us to judge of the progress, arrest, or diminution of the infective pathological processes, at the same time improving the child's nutrition,

should it seem necessary, by the administration of tonics and nutriments. In that variety where the morbid processes are initiated in the synovial membrane, aspiration and overdistention of the joint with a two or three per cent. warm carbolized solution or with an emulsion of ether-iodoform is occasionally curative, although not devoid of danger. It is safer to trust to elastic compression and fixation of the joint. If the synovitis becomes suppurative, a free incision and persistent warm antiseptic irrigation may save the joint.

Acute infectious osteo-myelitis is distinguished from myeloid tuberculosis by its greater constitutional disturbance, its agonizing pain, involving usually multiple bones and joints, and the rapidity of its course towards suppuration and epiphysial destruction. It is most frequently mistaken in its early clinical history for rheumatism, growing pains, or typhoid fever. As soon as its nature is recognized, the indications for treatment are to relieve tension, lessen pain, and support the strength of the patient. This can best be done by limiting the destructive processes by early incision, opening up the epiphysial ends of the affected bone, scraping and disinfecting the medullary canal, and iodoforming the infected area. Good drainage, fixation of the joint, and elevation of the affected part, with frequent change of dressings, constitute the most efficient treatment. Metastatic abscesses, pyæmia, and death often close the scene in this terrible disease.

**RHEUMATISM.**—Rheumatism affecting the minor articulations requires no particular mention, and is amenable to the same rules of treatment that apply to other articulations. Locally, chloroform liniment and camphorated soap liniment freely applied to the affected hands and feet, these being then covered with cotton batting and oiled silk, or enveloped in soft flannel bandages, have, according to my experience, been the most comfortable applications until the systemic treatment afforded relief. Subsequent stiffness of the fingers, wrists, or ankles may be greatly diminished by massage and passive motion.

Arthritis deformans is occasionally met with in the minor articulations of children, but this intractable affection is, fortunately, seldom seen.

**GONORRHOEA.**—Gonorrhœal infection of joints is usually observed as a synovitis of an essentially chronic character and likely to be followed by more or less loss of functional activity of the joint for an indefinite length of time. Exacerbations are common. The gonococcus expends its surplus energy upon the synovial membrane when it invades a joint. Out of three hundred and eight cases of gonorrhœal joint-infection, the minor joints were implicated one hundred and eleven times. In children it is so rare an affection that I have never seen an example of it under fifteen years of age. If seen, however, it presents the same peculiarities and is amenable to the same treatment as in the adult.

**GOUT** is unknown, so far as I am informed, among children.

**SYPHILIS.**—Joint-inflammations in syphilis may develop in either the secondary or the tertiary stage of disease. In the secondary stage the morbid phenomena of synovitis appear, while in the tertiary stage gummata

and a resultant peri-synovial hyperplasia, or a later osteitis of a degenerative type, demand our attention. Hereditary syphilitic joint-manifestations are observed more frequently in infants and children, and, according to Schüller, appear as a synovitis with localized patches of cartilage-necrosis, or as an osteo-chondritis along the epiphysial line with coincident periostitis and perichondritis.

The minor articulations are attacked in one-third of the cases observed. A differential diagnosis between rickets and inherited syphilis can usually be made by a history of the case and by an examination of the articular extremities of other bones, and especially of the costo-sternal unions. A history of previous miscarriages on the part of the mother, and of infantile snuffles and syphilides on the part of the child, is corroborative evidence of syphilis inherited by the child suspected of osteo-arthritis syphilis.

The treatment consists in local inunctions of oleate of mercury or mercurial ointment, and the long-continued internal administration of anti-syphilitic remedies, combined with tonics and attention to the hygiene of the child.

**PYÆMIC JOINT-AFFECTIONS.**—Pyæmic joint-affections, according to Barwell, are almost always multiple, and the smaller articulations frequently partake in the morbid processes. After lasting for a week or ten days, the severity of joint-symptoms is localized in one or two joints, as a rule. The disease is ushered in by pyrexia, rigors, and increased systemic disturbance; not infrequently the infection follows some slight traumatism over the phalangeal articulations. Often I have seen a slight incised or lacerated wound over a phalangeal articulation apparently heal, and a few days later give evidence of pyæmic invasion of the underlying or contiguous joints. The destruction is rapid, and, when there is a history of septic wound followed by joint-infection by the pus-microbe (*staphylococcus* and *streptococcus pyogenes, aureus* or *albus*), free incision, with antiseptic irrigation, is the surest and safest mode of relieving tension and saving the joint. At the same time the internal administration of quinine, iron, and whiskey is clearly indicated. General supporting medication, with local disinfection and drainage, constitutes the best treatment with which I am acquainted.

**METASTATIC JOINT-AFFECTIONS.**—Metastatic joint-affections are occasionally seen in children after an attack of the mumps. There is an increase of the quantity of synovia in the capsule. The joint becomes stiff, slightly painful, and somewhat doughy. Usually, under rest, equable compression, or hot fomentations, the synovitis disappears in the course of a few weeks.

#### ACUTE INFECTIOUS DISEASES LIABLE TO JOINT-COMPLICATIONS.

In regard to acute infectious diseases, such as scarlet fever, measles, small-pox, whooping-cough, diphtheria, typhus and typhoid fever, cerebro-spinal meningitis, erysipelas, septicæmia, etc., liable to be followed by joint-inflammations from an infection of the joint by the specific microbes of

these different diseases, it may be said that the infection either occurs through the medium of the circulation carrying the infective microbe to the synovial surface, or reaches the joint-surface from a separate focus of disease by the lymph-channels, or by direct extension from continuity or contiguity of surface.

Micro-organisms are found in the diseased joints corresponding to the micro-organisms of the general disease from which the little patient is suffering. This is now the generally-accepted belief of modern pathologists, and the occurrence of joint-complications in the acute infectious diseases is promptly recognized and its treatment based upon this recognition of the essential cause. The general treatment consists in the exhibition of remedies calculated to combat the general systemic infection of the particular infectious disease under consideration that gave rise to the local joint-symptoms, and the local treatment consists of rest, fixation, and elastic compression of the affected joint, or, later, of aspiration, incision, disinfection, and drainage, if extensive disorganization has occurred.

#### TUMORS.

The minor articulations of children are liable to the development of either chondromas or sarcomas, which may appear upon the joints of the hand from injury, or upon the distal toe-joints from shoe-pressure. They present the same clinical history here that accompanies their development in other localities.<sup>1</sup> The chondromas require complete excision, with removal of the cartilage-matrix, or they will certainly recur.

The sarcomas are usually central or medullary in their origin, although sometimes springing from periosteal or synovial surfaces, are rather rapid in their growth, and require amputation at the proximal articulation of the bone involved.<sup>2</sup>

---

<sup>1</sup> Cornil and Ranvier, *Pathological Histology*, 1882, p. 217.

<sup>2</sup> Marsh, *Diseases of the Joints*, 1886, p. 288.

# ANKYLOSIS.

By R. A. KINLOCH, M.D.

---

ANKYLOSIS (*ἀγκύλις*, "bent") is a term used to signify a more or less complete fixation of a joint as the result of chronic pathological changes affecting its component parts. The term has, however, been employed in a very indefinite sense, and without regard either to the character of the changes or to the special tissues implicated. Thus, limited movements of joints, the result of contracted skin or fascia, shortened tendons or muscles, induced voluntarily or involuntarily, have been included under the one name. Some authorities qualify the term so as to designate as *spurious ankylosis* all restricted movements of joints determined by changes of tissues exterior to them. Such *extra-articular* conditions may be referred to as complications, but will not be more particularly considered here. In ankylosis proper, the fixation is decided, if not absolute, and the changes are within the joint: the disease is *intra-articular*.

The joint or limb need not be bent, or crooked, as might be implied by the use of the Greek word. The relative position of the bones may vary; that is, the joint may be fixed at any angle, or the limb may be straight.

As the fixation must be decided, the connecting tissue will be limited in length for the union of the respective bones to be close. The firmness of fixation will depend largely upon the character of the uniting tissue,—its histological advance from the original granulation-tissue of inflammation. The terms fibrous, cartilaginous, and osseous ankylosis express this fact. True bony union does away with a joint, the contiguous bones being firmly connected; fibrous union occasions varying degrees of stiffness. The classification *complete* and *incomplete* ankylosis, adopted by some, was determined by the contrast presented by osseous union with an absolutely immovable joint and fibrous union with appreciable mobility.

Under either variety, very different conditions of the joint are found. The tendency of the fibrous form is to become osseous. Cartilaginous ankylosis is rarely met with, and may be looked upon as a transitional stage between the fibrous and the osseous. R. Volkmann described this as seen in young subjects after subacute coxitis without suppuration.

The kind of ankylosis is determined largely (1) by the character of the original cause, (2) by the continuance of the morbid processes to the lesser

or greater destruction of tissue, and (3) by the degree of reparative power prevailing in the structures implicated.

Thus, we find the fibrous ankylosis commonly associated with slight injuries, or with strumous or rheumatic conditions. The osseous, on the other hand, follows active pyogenic processes, or septic inflammations consequent upon severe traumatic lesions. Not infrequently, however, the two varieties coexist, and time only may be needed for the larger development of the more highly organized tissue.

In all cases of true *intra-articular* ankylosis a series of pathological changes can be traced progressively to the complete loss of function and final fixation of the joint. The synovial membrane suffers first, as a rule, the inflammation determining plastic effusion, cell-development, and formation of thick granulation-tissue. The adjacent capsule and other ligaments participate in due time in like changes. The articular ends of the bones become infiltrated with inflammatory products; the cartilages have their nutrient supply cut off, so that portions die, while the greater portion of the matrix liquefies under the invasion of the granulation-tissue formed from the synovial membrane and the articulating extremities of the bones; cartilage-cells proliferate and mix with the numerous cells of the granulation-tissue, and pus now occupies the joint. With subsidence of action the layers of granulation-tissue springing from the contiguous bony surfaces coalesce, and thus a fibrous bond of union is obtained. Subsequently ossification ensues, and bony ankylosis is the favorable termination.

In some instances the morbid process begins in the ends of the bones, and, again, at times it originates in the tissues exterior to the synovial sac. The final result, however, is seen in the changes above described, which are to eventuate in bony ankylosis.

The amount of the inflammatory product and its future development vary, and hence the observable variety in the extent of the adhesions and their nature. At times these are delicate and limited to small defined portions of the synovial membrane; or, again, the synovial membrane is practically replaced by stout bands of fibro-ligamentous tissue which closely connect the bones and arrest the function of the joint. More generally, as above described, the synovial membrane has been destroyed, and the fibroid tissue comes direct from the bones, where it has been formed from the granulation-tissue.

In regard to the osseous adhesions we may note equally variable conditions. There may be firm and abundant osseous material uniting the broad contiguous surfaces, the two bones, as it were, being fused into one; or there may exist narrow bridges of bone, with a predominance of fibroid tissue as the connecting medium. In fixation of some joints, as in the vertebral column, the osseous bridges may be entirely outside of the articulation. These cases would not properly come within our definition of true ankylosis, and their occurrence may with some be an objection to the classification adopted.



The secondary changes pertaining to the extra-articular tissues it is not our province here to describe.

**Causes.**—Ankylosis originates, as we have seen, from arthritis, and, consequently, may be traced to every kind and degree of traumatism of the articulations,—slight sprains or twists of a joint, luxations, contusions, wounds, fractures near or through joints, infective periostitis, osteo-myelitis, epiphysitis, pyæmia, struma, syphilis, contagious fevers, etc. Luxations and fractures are perhaps among the most common causes, being associated with injury of so many of the proper tissues of the joints, and with their long disuse as enforced by certain kinds of treatment, often too carefully and unnecessarily persisted in. That the long disuse of a joint under these circumstances may be a cause of ankylosis we prefer to admit, although the fact is denied by good modern authorities. The exercise of the functions of all organs is necessary to healthy conditions, and the absolute immobility of a joint will assuredly in time lead to troublesome and persistent stiffness, if not to positive ankylosis.

Where fractures penetrate a joint we find (1) a high degree of inflammation following the traumatism, (2) intra-capsular and extra-capsular blood-extravasation, (3) exuberance of callus, and (4) displacement of the fragments of bone and their encroachment upon the joint-cavity. All these hinderances to motion may lead secondarily to contraction of tissues and to true ankylosis. The constitutional causes above alluded to may often be regarded as mere complications determining the character and degree of the changes following upon the traumatism. Tuberculosis, if viewed in the light of a constitutional condition, must also, when met with primarily in the extremities of the bones or in certain other tissues pertaining to the joints, be regarded as a local process directly determining those pyogenic inflammations which are so destructive in young subjects.

**Diagnosis and Signs.**—In considering the diagnosis it must be presupposed that all acute action has subsided, and that we are not to consider those hinderances to mobility of a joint which are the natural concomitants of such action. It will in this view be no difficult matter to ascertain the existence of that degree of fixation constituting true ankylosis. Decidedly rough handling may at times be necessary to recognize signs, and it is often advantageous to both patient and surgeon to conduct the examination under an anæsthetic. In the hip- and shoulder-joints difficulty arises from the mobility of the pelvis and the scapula. The yielding of bones must not be confounded with mobility of the joints proper.

Chronic osteo-arthritis may be confounded with ankylosis. The history and age of the subject, the joints affected, and the existing deformity will assist in the differentiation of the two affections.

The diagnostic point more generally to be decided has reference to the *variety* of ankylosis: is it the fibrous or the osseous form that we have to deal with? Absolute fixation, without pain upon manipulation, proclaims the osseous form. But at times the fibrous variety gives apparent immo-

bility : so the examination must be carefully made. Some degree of pain with even the slightest yielding of the bones will decide the question. Bony formation outside of a joint, as is seen in the osseous bridges of a diseased spinal column passing from one vertebra to another, may occasion fixation where there is little or no intra-articular disease ; or, again, we may be deceived, as in the case reported by Bonnet,<sup>1</sup> where the femur and the tibia were fixed by a large mass of fibrous tissue occupying the popliteal region, the joint being healthy. These cases are so exceptional that they need not affect the classification which accepts only intra-articular changes as necessary to true ankylosis. Where fibrous union is so short and firm as to simulate osseous union, it may be safely concluded that this latter will finally obtain.

The positive differentiation of these varieties of ankylosis is at times a very practical question, inasmuch as a yet mobile articulation may mean continued local and constitutional irritation threatening the life of the individual, while an immovable one offers assurance of the cessation of irritation and gives hope of recovery. A correct estimate of the shortness and strength of the adhesions is also important, because bearing directly upon the treatment.

**Treatment.**—It is of primary importance to ascertain beyond doubt the degree and the character of the fixation of the particular joint. To this end an anæsthetic will avail much. All extra-articular hinderances to motion (false ankylosis) must be determined, for it may prove necessary to overcome these as preparatory to dealing with the intra-articular condition.

The original causes of the disease, local and general, and in certain cases more especially the septic or the non-septic character of the arthritis which established the ankylosis, must be duly weighed. In some instances the ankylosed condition must be regarded as a conservative result ; in others the very tendency to this should be combated by every resource of art, in order to preserve the function of the joint and the usefulness of the limb. Treatment aims at times to restore normal motion and function ; or, again, it rests satisfied with an approximation to so favorable a result. In special cases the malposition of the limb is the important thing to overcome. A leg bent at the knee may be a useless appendage, and an extended elbow a source of much annoyance. Such malpositions are often due to want of judicious treatment during the acute stages of the arthritis. This is now so well recognized that modern scientific treatment insists upon the avoidance of such evils. Lastly, as life is more valuable than a limb, the sacrifice of a limb may be preferable to persistent efforts for preventing or overcoming ankylosis or restoring usefulness by correcting malposition.

Preventive treatment we cannot discuss as fully as we should like in the limits assigned to this article. It resolves itself into the proper treatment

---

<sup>1</sup> Sur les Maladies des Articulations, tome i. p. 130.

of the preceding arthritis, acute or chronic. In connection with the important subject of luxations, and of fractures near or involving joints, preventive treatment cannot be too strongly urged. Accurate adjustment of articulating surfaces and of displaced fragments of bone, and the fixation of these for a definite time, will limit effusion and the formation of callus. Extravasated blood must be got rid of by aspiration or by compression and massage. In joints like the knee, the good effects of early aspiration are clearly evident. After the third or fourth day, methodical compression and massage give good results. These should be employed so as not to interfere with proper circulation or the adjusted fragments of bone. The rubber bandage applied directly, or over soft wool or cotton compresses, is most efficient. Splints and bandages may be temporarily removed after a week, and massage practised. Smaller contiguous joints, also muscles and tendons, must be actively or passively exercised once in five or six days, and the splints and bandages replaced. There should be no immobilization of a joint longer than is necessary for due repose and consolidation of the fracture. The time required for immobilization, we believe, is generally over-estimated.

Where soft union already obtains, treatment, except in cases where ankylosis is considered salutary, should be directed to preventing this from becoming osseous. Here passive movements, with gentle frictions, careful exercise, and gradual increase of extension and flexion, must be persisted in, if necessary for weeks and months. Any reaction following such movements should be regarded as an indication for longer suspension of exercise and for more moderate and careful manipulations.

In the fibrous form, when deformity and stiffening are marked, attempts must be made to overcome such and to restore the movements of the joint. We may resort to gradual extension by weight and pulley, or some form of screw apparatus. Numerous machines for this purpose have been invented, and can be found illustrated in most of the surgical treatises from the Middle Ages up to the present time. The simpler means are usually the best. The weight and pulley, with or without some kind of rubber extension force, will usually succeed if success is attainable. Preliminary division of tendons, muscles, fasciæ, or cicatricial bands may at times be necessary. No extensive division of such tissues should be made, however, until the use of an anæsthetic has enlightened us as to their extent and strength. Where cicatrices, especially of the skin, are firm, the extension must never be violent. We succeed best in overcoming these by repeated and slow stretching. Should rupture of exterior tissues occur, and an open wound result, the complication becomes most serious.

The treatment by gradual extension is necessarily slow, and in the end it often fails to establish the natural mobility of the joint. A quicker and generally more satisfactory method is by rapid and forcible extension or flexion under an anæsthetic, and at times after preliminary division of tendons. This is the *brisement forcé* of the old authors, and was originally,

when practised without anaesthesia, an operation of much terror. At the present day it is efficient as well as attractive. It saves valuable time.

Gentle movements should first be made in all directions, so as to get rid of minor obstacles. Often a sudden rotation or twist of one of the bones insures replacement, with yielding of the rigid structures of the articulation. The hands of the surgeon, alone, or aided by the manipulations of assistants, will usually suffice. At times powerful mechanical contrivances are brought into use.

Pain and swelling, with some reflex excitation of surrounding muscles, naturally follow such operations. The immediate after-treatment should seek to limit or prevent these painful results, and likewise to obviate subsequent deformity or malposition of the limb. A hypodermatic injection of morphine will usually be appropriate.

The limb should be carefully padded and bandaged from below upward, and a suitable splint adjusted to prevent extension or flexion. A plaster bandage at times is preferable to ordinary splints. Whatever contrivance is used, the indication is to *insure absolute rest of the joint*, and, together with this, moderate and uniform compression as an additional aid. We have seen excellent results from enclosing the joint and limb in a soft pillow and binding this tightly around with a bandage.

The immobility and support of the joint must be insured for eight or ten days, or until the swelling and irritation subside; then the further treatment will depend upon the result desired. If mobility of the articulation is sought, passive motion and massage must be carefully commenced; if permanent ankylosis is desirable, the limb must be fixed for many weeks in the position which promises the greatest utility. The judgment of the surgeon must determine the question, and also guide as to the frequency of the movements to be carried on, and as to the use or disuse of splints, bandages, and other apparatus. To relieve the pain and swelling following upon *brisement forcé*, or to prevent the occurrence of these, some authorities rely upon ice poultices to the joint, or use the metallic or rubber coil through which iced water is made to flow.

In the hip, knee, and ankle a firm ankylosis admits of a comparatively useful limb, and in directing treatment this must be borne in mind. In the shoulder and elbow there is greater advantage from mobility, and this must be sought by the means already referred to, or even by a resort to resection of the joint.

*Bony ankylosis*, when consisting only of feeble osseous bands, may be treated by the rapid and forcible method already described. But when the ends of the bones are fused together, or are connected by fibrous bands of great strength, the management must be different. Decided flexion and rigidity at the hip or the knee renders the limb useless, and the extended and immovable elbow admits of but poor use of the arm. A stiff shoulder-joint is not so serious, as the compensatory movement of the scapula, under continued exercise, serves the sufferer admirably well.

Attempts at forcible rupture of adhesions have occasioned subcutaneous fractures of bones above or below the ankylosed joint, and remedied to a large extent the previously-existing deformity. Thus, fracture of the thigh above the knee may enable us to straighten the limb flexed and ankylosed at the knee-joint. As subcutaneous fractures usually unite without difficulty, the practice of fracturing the bone has been adopted as a means of treatment; or, what is better, an osteotomy through the ankylosed joint, or through the bone above, may be resorted to. At the knee, Barton's operation, in which a wedge-shaped piece of bone is removed, enables us to straighten the limb and to treat it as after a fracture; or a subcutaneous section of the femur, above the joint, may be made with the chisel or saw. In the hip the subcutaneous section of the neck of the femur may be made with Adams's saw. A clean resection of the joint at times may be preferable. Resection simply with the view of giving mobility, as often practised at the elbow, is of doubtful propriety. If "all turns out well," as Billroth remarks, "the limb is occasionally quite useful. But this is the point we cannot always insure; and who would risk his life for a stiff elbow?"

# DEFORMITIES OF BONE.

## OSTEOCLASIS AND OSTEOTOMY.

By A. G. GERSTER, M.D.

---

### I. INTRODUCTORY REMARKS.

THE osseous deformities requiring surgical correction are: ill-united fractures; irreduced dislocations of old standing (Macewen); the various forms of malformation due to rickets, as knock-knee, bow-legs; the various curvatures of the femur and the bones of the leg; pes valgus; and, finally, the pathological condition known under the name of rachitic contracted pelvis. We have to add the many forms of contracture and ankylosis of the several joints of the human body due to osteo-myelitic, tuberculous, or rheumatic processes that have run their course either in the affected joint or in its immediate vicinity. Finally, osteotomy or osteoclasis, or both, may be employed, in conjunction with preceding open division of the soft parts, for the cure of club-foot (Phelps).

### II. OSTEOCLASIS.

**Definition and History.**—The artificial production by the surgeon of a *subcutaneous* fracture is called osteoclasis (ὄσσειον, “bone,” κλάζω, “I break”). Its distinctive characteristic is to be sought in the avoidance of an injury to the integument. That the great value of this feature has been fully comprehended by the surgeons of all ages, is testified to by the early attempts at its intelligent practice, as recorded in the history of surgery, and by the names and descriptions of a number of venerable though clumsy apparatus, as, for instance, the “scamnum Hippocratis,” the “tripastum Archimedis,” and the “glossocomium Nymphodori.”

But until recent times a serious defect in the methods of the procedure militated against the popularization of osteoclasis. Whenever a fracture was to be produced near the middle of a long bone, existing apparatus or manual force gave the surgeon to a certain extent the power of locating the artificial separation in the vicinity of the point of selection. But the nearer he was obliged to approach an epiphysis the more uncertain and risky became the result of his endeavors. Injuries were produced not intended

by the operator, and often of a serious character, while the object of his intentions remained unaccomplished.

*Manual Osteoclasis.*—Recent, badly-united fractures and non-eburnated rachitic curvatures of the shaft of the long bones of children can often be corrected by the use of purely manual power. The hands of the surgeon, after firmly grasping the limb above and below the site of the intended fracture, are steadied by resting them upon the couch or table occupied by the anæsthetized patient. The thumbs in juxtaposition serve as a fulcrum over which the fracture is produced. The surgeon's knee or the edge of the table may also serve as an efficient fulcrum (Tillaux).

Delore, of Lyons, invented a new name for an old thing. His *redressement forcé* or *brusque*, recommended for the correction of genu valgum, consists in the following steps. The patient's limb is so placed upon the table that the external malleolus and the outer aspect of the thigh are in contact with it. In this position the deformed knee represents the apex of a triangle, the base of which is the surface-line of the table. By his hands, the surgeon brings to bear upon the projecting knee sufficient force to cause a separation of the resisting parts. In children and adolescents a separation of the femoral epiphysis results, and the ultimate issue of the procedure is not unfrequently a good one. But after the sixteenth year, when the ossification of the epiphysial cartilages is more or less complete, rupture of the lateral ligament and distention of the crucial ligaments were so frequently observed, followed by greater or lesser laxity and disability of the joint, that the crude and dangerous procedure was generally abandoned. The long duration of the healing process after the use of Delore's method (from two to five months in children) hastened its final condemnation.

The uncertainty and lack of precision in the employment of osteoclasis were sufficiently great to overcome the prevailing and well-founded fear of suppuration of even as ancient authorities as Paulus Ægineta (660)<sup>1</sup> and Avicenna (died 1037),<sup>2</sup> both of whom recommended, for the cure of fractures united in a vicious position, the exposure of the deformed callus and its division by the chisel, in preference to osteoclasis.

It is natural that the comparative ease with which a fracture can be effected in the middle of the shaft of a long bone should invite practitioners to employ it in suitable cases. And so we see G. M. de la Motte and Jan Muys, about the year 1700, practising *osteoclasis by distention* in cases of deformed callus with shortening. About the same time, or later, three German surgeons, Purmann, Bosch, and Oesterlen, perfected this extension method by adding to it a new and fruitful principle,—namely, that of *lateral pressure* brought to bear from above upon the convexity of the deformed mass of bone. Their several apparatus are all based upon the idea of the common book-press.

<sup>1</sup> Paulus Ægineta, De Re Medica, Cornaro interprete, liber vi., cap. cix., p. 601.

<sup>2</sup> Avicenna, Liber Canonis, liber iv.

The name invented by Oesterlen for his apparatus is a fair exponent of its simplicity and handiness. It is the nonosyllabic "dysmorph-osteopalın-klastes."

In the year 1845, Rizzoli, of Bologna, Italy, invented a simplified and very effective apparatus for the production of fractures of the shaft of the long bones. Each end of a steel rod is attached to the limb by a strap. Exactly corresponding to the place where the fracture is desired, a pad is fitted to the limb. On the posterior aspect of this pad impinges a strong screw, playing through a threaded hole of the steel rod. Each turn of the screw tends to depress the pad, which attacks the bone at a place devoid of support; and, the pressure being raised to a sufficient degree, the procedure will terminate in a fracture at the place where the pad is applied. For obvious reasons, this apparatus lacks the qualities necessary for the production of fractures near a joint.

Von Bruns's modification of Rizzoli's instrument, Schneider-Menel's and Heine's apparatus, Esmarch's osteoclast, and Volkmann's engine, consisting of an iron hoop and a long lever, had no characteristics that would markedly distinguish them as preferable to Rizzoli's original osteoclast.

We owe the most noteworthy and indisputable advance of the technique of osteoclasis to Robin,<sup>1</sup> a French surgeon, whose great success was needed to overcome the strong prejudice entertained by his countrymen against the practicability of the procedure, fostered by Dupuytren's erroneous dogma, that the breaking of a callus was impossible after the lapse of sixty days following the fracture to which it owed its existence.

Pousson<sup>2</sup> cites a number of cases in which refracturing of callus was successfully done two hundred, three hundred, and seven hundred days after the original injury. Billroth repaired a badly-united fracture of the leg of a middle-aged woman four years after the time of the injury.

Robin's apparatus consists of a solid board, representing a slightly-inclined plane, which serves as a firm base of support to the entire length of the limb to be operated on for genu valgum. A gutter made of steel is fitted to the superior aspect of the member. Its shallow concavity permits the lateral shifting of the soft parts of the limb, thus preventing undue pressure and bruising of muscles, vessels, and nerves. By means of four threaded uprights and a corresponding number of screw-heads, two strongly-wrought steel hoops, fitting the anterior and posterior edges of the gutter, are made to bear the requisite pressure upon the limb for its immovable fixation to the board. (Fig. 1.)

No fear need be entertained regarding the safety of the soft parts, and the screws have to be brought down with a good deal of force to secure immobility. Pousson has demonstrated the permeability of the popliteal

---

<sup>1</sup> *Traitement du Genu Valgum à tous les Ages par un nouveau Procédé de l'Ostéoclasie mécanique*, Thèse de Lyon, 1882.

<sup>2</sup> *De l'Ostéoclasie*, pp. 89, 90, 96, 97.



artery during his experiments, by maintaining through it an uninterrupted current of water while the limb was subjected to the utmost pressure by the operation.

FIG. 1.

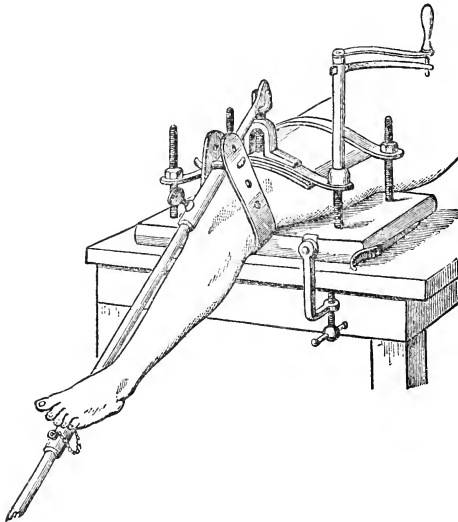

Robin's osteoclast.

The upper part of the femur being thus fixed, a heavy but narrow leather strap is slung about the condyles from below, its ends being caught up by a suitably-shaped clasp of steel. A powerful lever, being now carried through under this clasp, is movably attached to a forked staple resting upon the anterior steel hoops: thus the apparatus is made ready for action. The surgeon grasps the projecting end of the lever, and by a brisk upward movement the fracture is effected, and is attested by an audible cracking noise. The limb, being freed from the apparatus, is immediately encased in an immobilizing splint in a corrected position.

It is evident from the nature of the apparatus that the fracture can take place only where the steel gutter and the leather strap meet.

However precise the action of Robin's apparatus may be, its drawback is, that variously shaped and sized gutters and hoops are required for its application to limbs of different degrees of development. For the hip-joint the principle had to be made practicable by the construction of quite another apparatus, in the use of which the *distal* part of the lower extremity is fixed upon the base-board, the leather strap being applied next to the joint, when by means of two powerful levers a very precise fracture can be produced.

Another Frenchman, the surgical cutler Collin, also invented an osteo-

clast, in the year 1879; its object was the correction of knock-knee by osteoclasis. It was much inferior to Robin's apparatus in every respect, its *modus operandi* being identical with the process of Delore's method, with the addition of an increased capacity for mischief, due to the augmentation of dynamic power. This apparatus was soon superseded by a second device of the same inventor, which was manifestly fashioned upon the idea embodied in Robin's osteoclast.

Beely, of Berlin, has recently increased the number of known osteoclasts by the construction of a new apparatus,<sup>1</sup> the working of which will be readily understood by reference to the subjoined cut (Fig. 2). As estab-

FIG. 2.

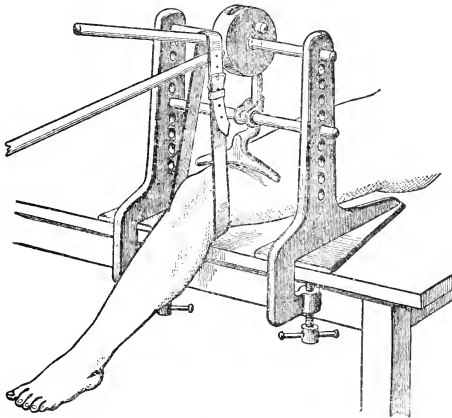

Beely's osteoclast.

lished by a sufficient number of experiments, its action is as reliable and precise as that of Robin's apparatus, and it is suitable for limbs of all shapes and sizes. It is also equal to Robin's instrument in this respect, that the soft parts and the periosteum are not injured, and that the line of fracture is transverse in the main, and not complicated by comminution.

The newest addition to our osteoclastic armamentarium comes from Italy, where Ferrari<sup>2</sup> has presented what is undoubtedly the best osteoclast for the treatment of knock-knee. Its ingenious simplicity is evident from the illustration (Fig. 3), and its effectiveness is attested by its author and by other writers.

**Application of Osteoclasis.**—Before entering into the discussion of the merits and limitations of osteoclasis, due mention has to be made of the non-operative, hence slow, method of correcting bony deformities, as

<sup>1</sup> Buttersack, Inaugural Dissertation, *Über Osteoclasie*, Berlin, 1887.

<sup>2</sup> *Archivio di Ortopedia*, vol. iv., parts 1 and 2, Milan, 1887.

promulgated by Sayre in his work on orthopædic surgery. Its value in cases of knock-knee of recent origin, where the eburnation of the deformed

FIG. 3.

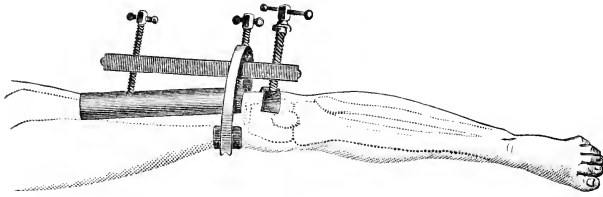

Ferrari's osteoclast.

bone has not yet taken place, is undeniable. In properly-selected cases its employment will meet with gratifying success.

FIG. 4.

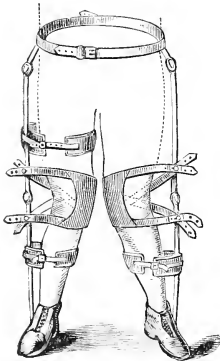

Sayre's knock-knee apparatus.

Osteoclasis holds the same relation to osteotomy that obtains between a subcutaneous and a compound fracture. A fracture for the sake of needed correction of a deformity is produced in the former case without, in the latter with, external wounding and its concomitant dangers. It is true that the dangers of osteotomy have become very slight indeed, whenever the surgeon is a competent aseptician. Nevertheless it would be vain to assert that osteotomy is or ever can become absolutely free from the dangers of supuration. The disadvantage of instrumental osteoclasis as compared with osteotomy inheres in the bulkiness of the needed apparatus, which circumstance is no objection to its use in hospitals, but militates against its application in private and especially in country practice. Another

defect of the method is that it is inadmissible in several groups of bony deformities, as, for instance, contractions and ankyloses, for reasons presently to be mentioned.

Let us now examine under what conditions instrumental osteoclasis can be recommended as safe; and, on the other hand, let us see what will contra-indicate its practice.

*Instrumental osteoclasis is advisable:*

1. In rachitic curvatures of the long bones of children over two years old, which are not amenable to Sayre's treatment by gradual correction on account of advanced hardening or eburnation of the bone.
2. In badly-united fractures of the shaft of the long bones of children and adults.
3. In such cases of knock-knee at all ages as are not amenable to

Sayre's treatment, and in which even the slightest risk from suppuration must be avoided, for various reasons. One of the cogent indications for the selection of osteoclasis would be the unfamiliarity of the surgeon with the antiseptic discipline.

*Osteoclasis is not advisable :*

1. In contractures and ankyloses of joints previously affected by acute suppurative or tubercular processes (white swelling). The contra-indication here is based upon the fact that the unavoidable traumatism connected with osteoclasis tends to rekindle a quiescent pyogenic or tuberculous focus from latency to full activity. Dangerous possibilities can thus be called forth to mischievous activity, which would remain unprovoked by the gentler though more incisive methods of osteotomy.

2. In badly-united fractures located near and perhaps closely related to a joint, especially where there is chronic joint-trouble caused by the preceding injury. Here, also, osteotomy would deserve the preference.

3. In deformities due to rheumatic joint-trouble.

4. In deformities consequent upon unreduced dislocations of old standing.

### III. OSTEOTOMY.

**Definition.**—Osteotomy is the exposure of a bone by incision, and the subsequent separation of its continuity by means of a saw or chisel. The object of osteotomy is the artificial production of the equivalent of a compound fracture. The injury, however, is devoid of the usual ominous accompaniments of a compound fracture, such as extensive laceration of the soft parts, the comminution of bone, the injury to vessels and nerves, and last, but not least, the frequent soiling and septic infection of the wound by contact, which forms one of the chief elements of danger in accidental compound fractures. In osteotomy there is a clean and small wound of the soft parts leading from the surface to the bone, as a direct and simple continuation of which appears a smooth and straight section of the bone. There is no extensive wounding of the skin or muscles, no pocketing caused by laceration due to the incalculable ways of one or more sharp fragments, wielded by the often enormous forces of accident; antiseptics prevent the introduction of substances apt to inaugurate suppuration, such as do very frequently find their way into the wound in compound fractures. The selection of the site of the osteotomy, and the absence of violence,—in short, the gentleness of the whole process,—insure against accidental injuries, from which few operations are as free as this one, even in unpractised hands.

**History of Osteotomy.**—As stated in the preceding pages, the first mention of osteotomy is by Paul of Ægina, in 660 A.D., followed by the Arabian Avicenna (980–1037): both of these writers recommended the exposure of a hard deformed callus by the chisel, and its division by the same instrument. After Avicenna's time the operation fell into oblivion for over eight hundred years. Not until 1821 do we find any evidence of its

revival, when Wasserfuhr carried out the Æginetan's indication. In 1826 Riecke also performed osteotomy for the rectification of vicious callus.

In America, John Rhea Barton, a Philadelphian, had the courage to take up osteotomy again, and displayed remarkable originality in applying the operation to a new field. Samuel Gross<sup>1</sup> gives the following description of the first osteotomy performed for the cure of ankylosis: "A crucial incision was carried through the integuments over the most prominent part of the great trochanter, when, raising the flaps thus defined, the muscles connected with this portion of the bone were detached, a passage being thus made both in front and behind the femur for the easy introduction of the finger. With a saw constructed for the purpose, the bone was divided through the great trochanter and a part of its neck in a transverse direction." The case terminated successfully. In 1830 Dr. Rodgers, of New York, excised a wedge-shaped piece of bone below the trochanter for ankylosis of the hip-joint, and in 1835 Barton performed a cuneiform osteotomy for the cure of an ankylosed knee-joint. Gross states that "of fourteen cases of this operation of which the results have transpired, twelve recovered, and two perished of hectic irritation and exhaustion respectively. The success would thus seem to be eminently flattering."

The operation met with further development in Germany, where in 1852 A. Mayer published a noteworthy paper<sup>2</sup> on the subject, which seems to have served as an impetus for Langenbeck to perform the operation with the aid of a new principle. His first *subcutaneous osteotomy*, by means of a small straight-pointed saw, was done in the same year for ankylosis of the hip-joint, and was soon followed by a similar operation for ankylosis of the knee. In 1854 we find a record of several operations for rachitic deformity of the leg. Suppuration was the rule in Langenbeck's cases. After Langenbeck a number of modifications were introduced in quick succession by various surgeons. Brainard invented (1854) *subcutaneous perforation of the bone*, which was adopted by Pancoast and Gross (1859) for the cure of ankylosis of the knee. Sayre, of New York, published in 1862 a new procedure for the correction of hip-joint ankylosis, which consisted in the removal of a semilunar section of bone from above the lesser trochanter. In 1868 we see Stromeyer Little in England and in 1870 Billroth in Vienna using the chisel for the first time in subcutaneous osteotomy. In 1869 William Adams divided with a saw the neck of the femur for bony ankylosis, and in 1873 Volkmann performed his first cuneiform osteotomy below the great trochanter.

Although the results of subcutaneous osteotomy were considerably better than those observed after open section, yet the ultimate issue of a vast number of cases was put in great jeopardy by the frequent occurrence

<sup>1</sup> A System of Surgery, 5th ed., 1872, vol. i. pp. 1092, 1093.

<sup>2</sup> Die Osteotomie als orthopädisches Heilverfahren, Verhandlungen der Med.-Physik. Gesellschaft, 1853.

of suppuration. If we consider how bulky and clumsy an instrument the saw or a chisel is in comparison with a tenotomy knife, we must admit that most of these operations were "subcutaneous" in name only. As far as safety from suppuration was concerned, they were much inferior to subcutaneous tenotomy.

Volkman, of Halle, deprived the procedure of its last terror—suppuration—by inaugurating in 1874 the new era of *antiseptic osteotomy*. Macewen performed in 1875 the first antiseptic osteotomy in Great Britain, the second was done by Lister in the winter of 1875-76, and the third by Ogston in 1876 for genu valgum. Barwell, of London, followed in the same year, and since then the operation has been universally adopted as "safe, certain, and most successful" (Macewen).

**Application of Osteotomy.**—*A. General Remarks.*—Among the great variety of instruments devised and recommended for osteotomy only those will be considered that have met with universal acceptance. They are Adams's saw, the chisel, and Macewen's osteotome.

Adams's instrument, according to his own description, is a small saw "rather more than a quarter of an inch in width, with a cutting edge an inch and a half in length at the end of a blunt shank three inches in length." On account of the simplicity of its use, it is still by many surgeons preferred to any instrument of the chisel order. The weight of Langenbeck's objection, that the bony debris deposited by the saw be-

FIG. 5.

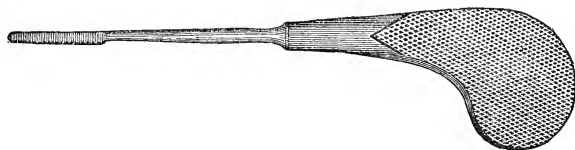

Adams's saw.

tween the cut bone-surfaces is apt to act as a foreign body, causing suppuration, has been much diminished by the use of aseptic methods, under the protection of which the osseous sawdust is readily absorbed. A more valid objection to the saw is the danger of laceration of the soft parts, with which the instrument must needs come in contact during its to-and-fro movement. But asepticity has rendered even this element of danger very slight indeed.

The chisel and Macewen's osteotome differ from each other in this, that the former has a bevelled cutting edge, whereas the osteotome has the shape of an attenuated double inclined plane, or a wedge. The chisel, as used by the author, is identical in shape with the ordinary carpenter's chisel, differing from it only by its fine temper.

A solid wooden handle is a great convenience in doing clean and precise work, for which a firm grip is indispensable. A half-inch and a quarter-inch blade will answer every purpose, the rule of safety being, in order to

avoid injury by the projecting edge of a too wide implement, always to use a chisel somewhat narrower than the width of the bone to be cut. The temper of the chisel must be that of the tools of the hard-wood- or ivory-carver. The edge of softer stuff will be turned; harder material is apt to snap off in the wound. The best test for the temper of surgical chisels is the femur of an ox. As the principal object of the chisel is the paring of fine shavings and the removal of wedge-shaped sections of bone, its edge should be kept very keen, so as to catch the bone when brought in contact with it.

The osteotome is the true "bistouri des os" (Billroth), or "bone-scalpel," its object being the production of a clean and straight section through any accessible bone in a desired direction. It is a formidable rival of the saw, and the objection that its use requires more skill and familiarity than that of the saw is far overbalanced by the advantages of the absence of bony débris and the avoidance of laceration of the soft parts. Another advantage of a well-tempered chisel or osteotome is the ease with which its edge can be sharpened, without any special tools or skill,—an important consideration in country practice.

Macewen's osteotome, its edge being evenly bevelled on both sides, will, on being driven through bone, not suffer a deflection to one side as an ordinary chisel would, but will maintain its direction unerringly until the section is completed. It "is an instrument of the chisel order, bevelled on both sides, so as to resemble a very slender wedge. The handle and the blade form one piece. The handle is octagonal, which is preferable to the oval or cylindrical, as it affords a better grip, and enables the operator to readily detect any deviation."<sup>1</sup> The top of the instrument has a projecting head. One of the lateral borders of the blade is marked with half-inches, to enable the surgeon to estimate the depth of its penetration. The edge of the instrument should be sharp enough to pare easily the finger-nail. The manner in which the requisite temper of the edge is produced is carefully described by Macewen.<sup>2</sup> If the bone to be divided is very thick and dense, several osteotomes of various sizes are to be used. Macewen's set contains three blades. The thickest is first employed until about one-half of the bone is penetrated; the second, of medium thickness, is introduced into the groove made by the first, and is put aside to admit the third or most slender one only when the deepest layers of bone are to be divided. The osteotome commends itself to the aseptic surgeon's favor by its effectiveness, its simplicity, and the great ease with which the instrument can be kept *absolutely clean*, an advantage not possessed by the saw.

The mallet to be used should be one of hard wood,—lignum vitæ or boxwood. The old-fashioned metal mallets usually furnished by the instrument-makers are too small and too light for serious work.

<sup>1</sup> William Macewen, *Osteotomy*, London, 1880, p. 68.

<sup>2</sup> *Op. cit.*, p. 69.

To the safe performance of osteotomy anaesthesia is indispensable. Whenever possible, artificial anaemia should also be procured by the use of Esmarch's band. Scrupulous asepsis—that is, extreme surgical cleanliness—is to be observed. This is accomplished by the careful shaving, scrubbing, and disinfection of the field of operation and its vicinity. Clean towels dipped in an antiseptic solution are so wrapped about the limb to be operated on as to leave exposed only the amount of space which is indispensable for the performance of the surgeon's work. The surgeon and his assistants and the nurse or other adjuvants should carefully see to the cleanliness and disinfection of their hands and finger-nails; the instruments, especially the saw, should be rendered aseptic by previous boiling, and should be kept ready for use immersed in a three-per-cent. solution of carbolic acid. A stream of irrigating fluid should continually wash away débris escaping alongside of the saw.

After the completion of the section, which if properly done will not cause injury to important vessels, a short pledget of iodoformized gauze is placed over the small wound, and this is enclosed in an ample antiseptic dressing. Esmarch's band is removed, and, if there be no evidence of excessive hemorrhage, the limb is encased in an immovable splint of plaster of Paris or some other material in a correct position. Should the dressings become immediately soaked with blood, exposure of the wound and instant search for the severed vessel, followed by its safe ligation, should be instituted. If the accident has required an enlargement of the external wound, this should be closed, with the exception of so much of its extent as would correspond to the size of the original osteotomy-wound. After this the case should be treated as above mentioned. The patient's comfort will require an opiate for the first and second nights; after that, as a rule, no anodynes will be needed.

The subsequent course of the after-treatment is identical with that of a simple fracture. Fever is rarely observed, although slight rise of the temperature, without sickness, headache, and general dejection, is often present on the second and third days after the operation.

The splint is removed at a time when consolidation is likely to have occurred. The external wound will usually be found healed on the removal of the splint, which, however, should consolidation be found incomplete, ought to be replaced by a new cast.

Regarding the *technique of wielding the saw, chisel, and osteotome* some remarks may be appropriate. The prolonged use of a key-hole saw, of which Adams's instrument is a modification, is extremely fatiguing to one unaccustomed to sawing; hence the surgeon should see to two things in order to husband his strength and to complete the section with some rapidity. The interstices between the teeth of the saw soon get clogged by a sticky paste consisting of fine bone-dust and blood, and, when this occurs, the utmost exertion is needed for continuing the section. It is therefore advisable to have on hand more than one saw, and by changing the implement give an



assistant a chance to clear it of débris. As a matter of course, the saws should be properly sharpened before use. Finally, the surgeon should assume that position in which the unusual and prolonged strain of working a small saw through a thick mass of hard bone can be most comfortably accomplished. If these points are observed, undue fatigue will not engender impatience and violent efforts, which, however inefficient in dividing the bone, will certainly lead to unintended injuries by laceration of the soft parts. A proper position of the patient, and a firm fixation, by the assistants, of the bone to be cut, are also indispensable to rapid and clean work.

In using the chisel for the removal of a wedge-shaped piece of bone, a proper bedding of the limb on a cushion (eighteen by twelve inches) loosely filled with dampened sand, and ample exposure of the bone by means of adequate incisions, are necessary. The bevelled side of the chisel should be held towards the part that is to be removed. Attempts at the removal of too large a wedge will lead to splintering of the bone or to the snapping of the chisel. It is more workmanlike to remove many small wedges in succession, methodically deepening the bone-wound to its proper extent. When the division is nearly complete, the remnant of the bony bridge can be snapped off without great effort.

Macewen's osteotomy requires a solid bedding of the limb on a sand-bag. The soft parts should be divided by a "sharp, clean, single incision" (Macewen) about an inch long, getting to the bone as directly as possible, and, if feasible, the knife should be carried parallel to the direction of the muscular fibres to be traversed. The knife is to be held *in situ* and not withdrawn until the osteotome is slipped in alongside of it down to the periosteum. Now the edge of the instrument is lightly turned, so as to cross the longitudinal axis of the bone. The locality of the incision ought to be so placed as not to involve injury to more than insignificant vessels. Beginners will do well to make an ample incision, so that the steps of the operation shall be amenable to the control of the finger-tip, or even of the eye.

*B. Special Application of Osteotomy.*—The indications for the performance of antiseptic osteotomy may be summed up as follows. It is advisable:

1. In cases of badly-united fracture where either the long duration of the deformity or its unfavorable position near a joint renders manual osteoclasis impossible.

2. In cases of bony ankylosis of certain joints, caused either by acute suppurative (osteomyelitic), by tubercular (strumous), or by rheumatic processes.

This class of cases is especially unsuitable for osteoclasis. Aside from the mechanical difficulty of fracturing the bone in close proximity to a joint, it is to be remembered that considerable traumatism accompanying osteoclasis is very apt to rekindle the process that has led to the formation

of the ankylosis. So, for instance, an apparently terminated osteo-myelitis may reappear, or a tubercular affection long since dormant may again become active.

3. For the correction of all rachitic deformities amenable to such treatment the advantage of osteotomy over osteoclasis is as prominent here as elsewhere. It is applicable and successful both in those cases which are otherwise suitable and in those which are unsuitable for osteoclasis.

1. *Badly-United Fractures.*—No specific rules can be laid down for the osteotomic division of badly-united fractures. As regards the general principle of the procedure, it may be said, however, that the artificial division should follow the line of fracture. In those cases of extreme longitudinal displacement where the fracture-surfaces are considerably removed from each other, the object of osteotomy is to divide the callus in such a manner as to produce a condition similar to that found immediately after the accident. After the division of the bone, secure fixation of the limb in a correct position becomes necessary. Where rotary or lateral displacement is the cause of the deformity, reduction and proper fixation in a stiff splint, with or without weight-extension, will be a comparatively easy matter. But where the shortening of the limb is due to excessive longitudinal displacement, followed by corresponding retraction of the soft parts, reduction will not be found easy, and, if accomplished, proper fixation of the fragments will require special measures, such as nailing or wiring. In extreme cases, where the shortening of the soft parts offers insurmountable obstacles, resection of a portion of the continuity of the bone will be necessary to permit easy apposition and fixation.

2. *Ankylosis in a Vicious Position.*—(a) *Hip-Joint.*—When there is bony union of the head of the femur with the pelvis as a consequence of precedent osteo-myelitis, tuberculosis, rheumatism, or dislocation, the position of the limb being such that in the erect posture of the patient the foot does not reach the floor, correction is best effected by osteotomy.

According to the preferences of the surgeon the Adams's saw or Mac-ewen's osteotome will be selected. The accompanying diagrams (Figs. 6, 7, and 8) show at a glance the usual places at which the femur is divided for coxal ankylosis. The choice of place for the division will depend upon the peculiarities of each individual case. Where the neck of the femur has been more or less destroyed by disease, Adams's section cannot be done at all. In very fleshy subjects it may be extremely inconvenient, on account of the great depth of the wound. Sayre's plan, simplified by the omission of the laborious and useless removal of a disk of bone from between the trochanters, admits of very general application. Gant's subtrochanteric section seems to be the easiest of the three methods, because the site of the division is most accessible, and the diameter of the bone there is less than between or above the trochanters. Yet each of the three plans is safe, and has yielded excellent results.

The mode of operation is as follows. The anæsthetized patient is

placed as for exsection of the hip-joint,—that is, with the ankylosed hip uppermost. The diseased limb is steadied by the interposition of one or more cushions between the lower extremities. All antiseptic precautions

FIG. 6.

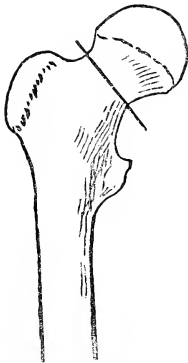

Adams's line of section. (Poore.)

FIG. 7.

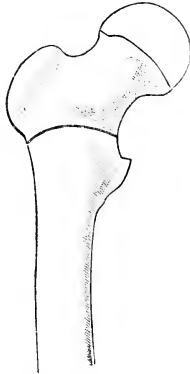

Sayre's intertrochanteric section. (Poore.)

FIG. 8.

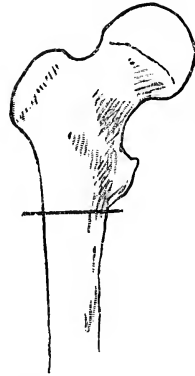

Gant's subtrochanteric section. (Poore.)

being taken, the surgeon makes a short longitudinal incision penetrating to the bone at the site of its contemplated division. If the saw is to be used, the soft parts are peeled off with an elevator from in front and behind the bone, and the section is proceeded with until about three-fourths of the bony mass are divided. The remainder is then snapped off by forcible adduction or abduction. When the osteotome is employed, the soft parts are not to be peeled off, but, the osteotome being introduced along the scalpel held *in situ*, and the latter being withdrawn, the bone is severed by a number of successive taps of the mallet, the last portion of the bony bridge being likewise snapped off, as formerly mentioned. The hemorrhage is inconsiderable. The thigh is brought down so as to occupy a slightly flexed (fifteen degrees) and somewhat abducted (five degrees) position, the wound is dressed, and the limb is secured either in a plaster-of-Paris splint or by weight-extension. According to the age of the patient, consolidation will be accomplished in from three to six weeks.

(b) *Ankylosis of the Knee-Joint.*—Ankylosis of the knee-joint at a considerable angle, whether due to bony union of the femur and tibia or to a cohesion of the patella with the tibia and femur, mostly complicated by subluxation of the tibia backward, and by great shortening of the soft structures occupying the posterior aspect of the limb, requires correction by osteotomy. Here forcible straightening is more dangerous even than at the hip-joint, as serious injury to vessels and nerves is to be apprehended.

Whenever the ankylosed joint forms an angle of less than one hundred and thirty-five degrees, simple osteotomy of the femur will be found suffi-

cient to correct the deformity. Ankyloses of between one hundred and thirty-five and ninety degrees of angularity require osteotomy of both femur and tibia, the result being a straight limb, which, however, presents in front a rather ungainly-looking prominence. The nearer the angle approaches ninety degrees, the more advisable becomes the return to Dr. Rhea Barton's original operation of excising a wedge-shaped portion of bone from the ankylosed knee-joint. This operation, if done aseptically, is not more dangerous than osteotomy, and its ultimate result is infinitely better in every way.

In performing simple osteotomy for ankylosis of the knee-joint, a small longitudinal wound on the outer side of the rectus tendon, on a level with a line drawn transversely a finger's breadth above the upper portion of the external condyle,<sup>1</sup> is made to extend down to the bone; the osteotome is introduced with its blade held longitudinally, then turned transversely; then two-thirds of the thickness of the bone are divided, and the remainder is snapped. If the tibia is

to be divided also, the section is made just below the anterior tubercle. The wound is to be made over the anterior tibial ridge, and the tibia is divided transversely. Should the soft parts resist full extension, one or more tenotomies are to be done in addition.

If excision of a wedge-shaped piece of bone be found preferable, a transverse incision, commencing over the middle of one condyle and passing over the patella to the middle of the other, will be found most convenient for the exposure of the parts to be removed. The periosteum is cut along the line of intended section, and then the condylar extremity of the femur and next the tibia are nearly cut through by the saw from in front backward. The remaining bridge of bone is snapped, and, the wedge being removed, the edges of the sections are evened with the saw or the bone-cutting forceps. The sawn surfaces are brought in apposition, and fixation is secured by the use

FIG. 9.

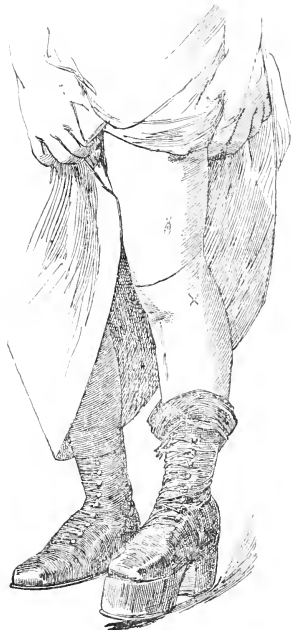

Final result after cuneiform excision of knee for ankylosis at a right angle.

<sup>1</sup> Macewen, p. 89.

of steel nails driven diagonally through the femur and tibia, and the application of a plaster-of-Paris or a dorsal T-splint. (Fig. 10.) Should the short-

FIG. 10.

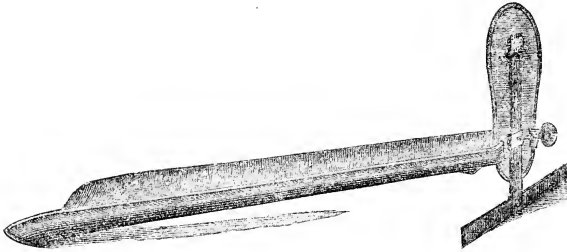

Volkmann's T-splint.

ened hamstrings offer too much resistance to the correction of the position, one or more subcutaneous tenotomies will have to be practised, until the desired position can be easily maintained. Care must be taken, however, not to injure the popliteal nerve or its branches: if there be any doubt about the identity of the resisting tissues, the safer course will be to expose freely the doubtful band and to make sure before section that it is tendon and not a nerve. The wounds are loosely sutured, an antiseptic dressing is applied, and fixation is secured by appropriate splints, as before mentioned. The dressings are left undisturbed for from two to four weeks, according to the age of the patient. On change of dressings the nails are withdrawn. The usual result is firm bony ankylosis and a very useful limb.

If the wedge of bone is to be removed by the chisel instead of the saw, it is better not to attempt to take away the whole wedge in one coherent mass, but rather to follow a plan similar to that employed by carpenters under similar circumstances. The size of the base of the wedge being outlined by two deepening grooves, the intervening bony structure is gradually chipped away until about three-quarters of the thickness of the bone are penetrated. The remaining bridge of bone is then fractured, and the fractured surfaces are properly pared off.

(e) *Ankylosis of the Elbow-Joint.*—Ankylosis of the elbow-joint in the erect or nearly erect position renders the upper extremity very awkward, and nearly useless for certain purposes, as, for instance, dressing and undressing, and the conveying of food to the mouth. Thus it may be desirable to improve the position and usefulness of the member by decreasing the angle at the elbow. The nearer this approaches a right angle, the better adapted becomes simple osteotomy for the correction of the position; that is, if ankylosis exists at an obtuse angle approaching to ninety degrees, simple osteotomy of the lower end of the humerus will readily permit easy and

safe correction. The division should be made from a longitudinal incision commencing at and extending upward from the apex of the internal epicondyle. About two-thirds of the thickness of the bone should be cut with the osteotome in a transverse direction, the remainder being snapped. The arm is then dressed and the elbow put up in a stiff splint at a trifle less than a right angle.

When ankylosis in a nearly erect position is to be corrected, we may either resort to osteotomy of the humerus, radius, and ulna, or, what is better, excise the elbow, when by appropriate after-treatment even a movable joint may be secured.

(d) *Ankylosis of the Temporo-Maxillary Joint.*—Osteo-myelitis involving either component of the temporo-maxillary joint may, after expulsion of the necrosed parts, result in osseous ankylosis of the lower jaw and the temporal bone. The patient loses the ability to separate the jaws, and hence cannot chew. Disability to consume solid food will, and often does, lead to serious impairment of the general health.

This form of ankylosis may be double, though, as a rule, it is unilateral. The ascertainment of the side which is ankylosed may prove difficult, and occasionally nothing short of a bloody exploration will decide the question. Severing of the bony union, with subsequent removal of the condyloid process by means of osteotomy, has been found to be an efficient way of removing this serious functional disability, and the method described by König<sup>1</sup> has been found by the author serviceable and safe.

An incision, beginning in front of the ear, is carried forward two and a half inches along the lower margin of the zygoma, care being taken to preserve the temporal artery intact. A second incision, involving the skin only, extends two inches downward from the middle of the horizontal incision. The soft parts are raised with the elevator from the bone, but occasionally very adherent periosteum has to be severed with a touch of the knife. The parotid gland and the facial nerve and vessels are displaced downward by means of a strong sharp retractor, and then the circumference of the condyloid process is stripped of its periosteum with a narrow elevator, care being taken not to injure the subjacent internal maxillary artery. The neck of the condyloid process is divided by the osteotome about half an inch below the joint. The jaws are pried open, and the remnants of the head and neck of the condyloid process are removed by the chisel and mallet from their temporal attachment. To avoid penetration of the cranium, the chisel should be directed downward and inward. The small wound is drained with a tube and closed by the requisite number of stitches, and an antiseptic dressing is applied in the usual manner. If no complications arise, the drainage-tube can be withdrawn on the third or fourth day, and the day after this, active use of the new joint should be commenced and diligently maintained, to prevent reankylosing.

---

<sup>1</sup> *Spezielle Chirurgie*, 1889, vol. i. p. 353.

3. *Rachitic Deformities.*—(a) *Knock-Knee.*—Genu valgum, one of the most common, painful, and disabling deformities of the locomotor apparatus, is, even in its more advanced forms, eminently amenable to successful treatment by osteotomy where osteoclasis would be deemed hazardous and orthopedic treatment futile. As it was known that the characteristic malposition of the tibia in knock-knee is caused mainly by the elongation of the internal condyle, it was natural that as soon as the safety of osteotomy was sufficiently established, this part of the femur should become the object of surgical attack.

FIG. 11.

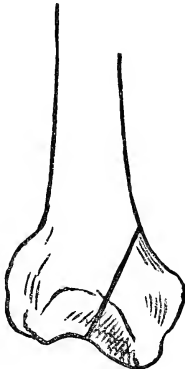

Ogston.

FIG. 12.



Reeves.

FIG. 13.



Chiene.

FIG. 14.



Macewen.

Older methods of osteotomy for knock-knee. (Poore.)

All the older methods, devised by Ogston, Reeves, Chiene, and Macewen, had the great drawback of saddling a simple osteotomy with the serious complication of invading the knee-joint, and all of them have been super-

seded in professional favor by MacCormac's and Macewen's methods of supracondyloid osteotomy (Fig. 15).

*Macewen's Operation.*—The limb, being carefully disinfected and rendered bloodless by Esmarch's band, is placed upon a sand-bag, where it is immovably held by the hands of two assistants. The detail of the procedure is thus described by the author of the method: "A sharp-pointed scalpel is introduced at a point where the two following lines meet,—one drawn transversely a finger's breadth above the superior tip of the external condyle, and a longitudinal one drawn half an inch in front of the adductor magnus tendon. The scalpel here penetrates at once to the bone, and a longitudinal incision is made sufficient to admit the largest osteotome and the finger, if the operator desires it. Before withdrawing the scalpel the largest osteotome is slipped by its side until it reaches the bone. The scalpel is withdrawn, and the osteotome, which was introduced longitudinally, is now turned transversely in the direction required for the osseous incision.

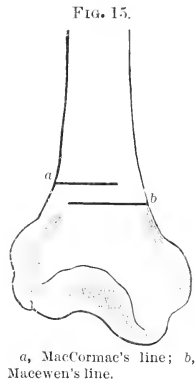

a, MacCormac's line; b, Macewen's line.

In turning the osteotome, too much pressure must not be exerted, lest the periosteum be scraped off. It is then convenient to pass the edge of the osteotome over the bone until it reaches the posterior internal border, when the entire cutting edge of the osteotome is applied, and the instrument is made to penetrate from behind forward and towards the outer side. After completing the incision in that direction, the osteotome is made to traverse the inner side of the bone, cutting it as it proceeds, until it has divided the uppermost part of the internal border, when it is directed from before backward, towards the outer posterior angle of the femur. In cutting on these lines there is no fear of injuring the femoral."

When the bone has been sufficiently divided,—that is, about two-thirds or three-fourths of its thickness,—the remainder of the cortical substance is snapped by an inward bending of the limb.

Eugene Hahn, of Berlin,<sup>1</sup> reports excellent results from a combination of MacCormac's and Macewen's incisions. (See Fig. 15.) He says, and with much justice, that simple osteotomy, as practised by Macewen or MacCormac, is a very tedious operation in cases where the bone to be divided is very hard or very thick, or both, and that a great deal of time is saved by attacking the condyle successively from both the external and internal sides. Then the osteotome need not be sunk to a great depth, as each section need not penetrate more than about one-third of the thickness of the bone, and the whole operation, though somewhat more complicated, is nevertheless much shorter, and it seems also safer, than the original procedure of Macewen.

<sup>1</sup> Centralblatt für Chirurgie, No. 48, 1888.



The little wound is temporarily protected by a wrapping made of a towel dipped in an antiseptic solution, until the other limb, if need be, is operated on. In extreme cases, division of the tendon of the biceps muscle may be required, to enable the surgeon to accomplish a perfect straightening of the limb. On account of the vicinity of the outer popliteal nerve, the tenotome ought to be introduced between the skin and the tendon, and the division of the tendon must be done *from without inward*, or, better yet, open tenotomy is performed.

The wound is now enveloped in a not too bulky antiseptic dressing, the Esmarch bandage is removed, and the entire limb is enclosed in a well-padded plaster-of-Paris splint, an assistant maintaining meanwhile extension in the corrected position until the plaster has set. In the absence of plaster, a dorsal T-splint or a solid veneer and starched bandage splint will answer the purpose just as well. Before leaving the patient, care must be taken to ascertain that the circulation of the limb is unimpeded. The normal color and sensation of the toes may be accepted as a test. If the splint be not too tight, an opiate will be needed only for the first night after the operation.

Should the rectal temperature rise beyond 101° F. during the first two nights, a careful physical examination must be made to ascertain the cause.

FIG. 16.

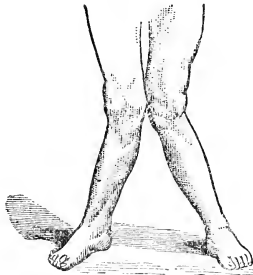

Case of genu valgum, moderate deformity.  
(From Macewen.)

FIG. 17.

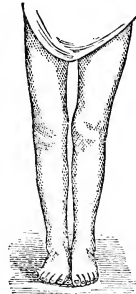

The same, after osteotomy.  
(From Macewen.)

Frequently a sore throat, pneumonia, or some other constitutional disturbance will be found to have caused fever. If the examination yield a negative result, and especially if severe pain be complained of at the site of the operation, some local disturbance within the wound or in its vicinity will have to be searched for, after the removal of the splint and dressing. Too much constriction, or else infection, will be found, and will require adequate treatment. The appearance of a slight blood-stain on the surface of the splint does not require its renewal. Dusting of the stain with iodoform powder, with exposure to the air, to hasten its drying, is all that is necessary.

If there is no pain, no fever, and no excessive staining by bloody effusion, the splint is not disturbed till the end of a fortnight, when it is removed, and in most cases the wound will be found nearly or completely healed.

After the removal of the first, a second splint is applied, and kept on until firm osseous consolidation is found to be complete. This may be expected in from three to six weeks from the date of the operation, according to the age of the patient. When the splints are removed, the patient should be encouraged to exercise his limbs in bed in the recumbent posture. When the joints have somewhat recovered their normal limberness, the patient is permitted to rise and to exercise with the aid of crutches. About ten weeks will elapse from the time of the operation until the full use of the limbs is recovered.

(*b*) *Bow-Leg*.—We have seen in the preceding section how in knock-knee the exact knowledge of the essential alteration of the outline of the internal femoral condyle has enabled the surgeon to direct his attack with great precision against the part needing correction.

In genu varum matters are very different. The deformity, instead of being dependent upon the morbid change of one well-defined locality, is distributed over a wider area. Instead of a simple lesion, consisting of the elongation of the internal condyle of the femur, we find here a more or less uniform outward curvature of one or two or all of the bones of the lower extremity, the greatest convexity being generally located about the knee.

Though the deformity as a whole is very apparent, the precise fixation of the site of the greatest curvature is by no means easy; hence the selection of the place where osteotomy can be done most advantageously is likewise somewhat difficult.

On careful examination, either the uppermost portion of the tibial diaphysis, or the external femoral condyle, sometimes the lower third of the tibia and fibula, or finally the middle of the shaft of the thigh, will be found deviating from the normal outline. In extreme cases two or three or even all of these elements may be present, as in Macewen's case reproduced in Fig. 18.

Accordingly, it is evident that in the graver forms of genu varum one osteotomy will rarely suffice to bring about perfect correction, and that the number of the divisions of the bone will have to be in direct proportion to the number of the single elements of the curvature. In the case shown in Fig. 18 Macewen performed ten osteotomies at one time, with an excellent result, illustrated in Fig. 19.

Regarding the technical management of osteotomy for genu varum the following rules may be laid down. Curvatures of the shaft of the femur are to be attacked from the outside of the limb. The cortical substance of the thigh is here very hard, and much patience will be required to accomplish division. If the outer condyle of the femur needs division, it will be

best to perform Macewen's typical supracondyloid osteotomy *from the inner aspect* of the thigh, this being the easiest and safest procedure.

FIG. 18.

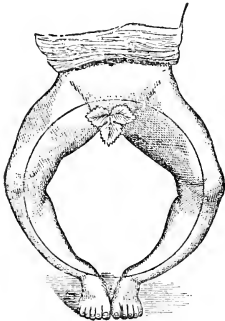

Aggravated case of genu varum.  
(From Macewen.)

FIG. 19.

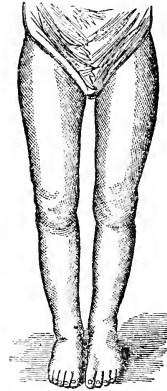

The same. Result after osteotomy.  
(From Macewen.)

Tibial division consists of the following steps. On the inner surface, midway between the anterior and posterior borders, and at the height of the lower edge of the tuberosity of the tibia, a longitudinal incision an inch or two in length is made through the soft parts to the bone. The osteotome being introduced in the well-known manner, the bone is divided from within outward and from behind forward. The densest bone will be encountered in the neighborhood of the tuberosity. Frequently the fibula can be snapped and requires no division by osteotomy. Should osteotomy be necessary, an osteotome has to be used of a diameter less than that of the fibula, to avoid injury to the soft parts. The lower the tibia is divided, the harder the bone will be found to be.

The dressings and after-treatment in osteotomy for genu varum are identical with those in genu valgum.

Knock-knee and bow-leg sometimes occur combined in the same individual, and each affection will have to be treated according to its proper indication.

(c) *Anterior Tibial Curvatures.*—These curvatures either involve the entire length of the tibia, when the tendo Achillis is found to serve as a string to the bow formed by the shin-bone, or are confined to the lower two-thirds of the bone, or to the lower third alone.

In the milder forms of the disorder, simple osteotomy of the most projecting part of the bone from before backward will be found adequate for the correction of the deformity. In direct proportion to the gravity of the aberration, two or more simple osteotomies may become necessary, or, better

still, cuneiform excision of the most prominent part of the curvature will have to be performed.

As a matter of course, rigid and efficient rules of asepticism form an absolute condition of these operations.

Cuneiform excision for anterior curvatures of the tibia is done as follows. Esmarch's bandage being applied, the fibula receives the first attention. If it appears from the age of the child or the hardness of the bone that simple snapping without osteotomy is not feasible, the fibula must first be divided by the osteotome.

The incision over the tibia is next made with the scalpel, penetrating to the bone, and of sufficient length to enable the surgeon to expose freely the area to be excised. A second, transverse incision is carried midway through the longitudinal slit in the periosteum, and the four periosteal flaps formed by the crucial cut are raised by the elevator and held aside with sharp retractors. Previous to all this the size of the wedge to be removed should be determined, by those who do not trust to their sense of symmetry alone as governed by the eye. The limb is laid on a sheet of card-board and the anterior outline of the tibia is traced thereon with a pencil. Then, parallel to this, another line is drawn at a distance corresponding to about the antero-posterior width of the tibia at the point of section. This pattern is now cut out, and will represent a rough lateral view of the curved bone. If this pattern is cut across at the point of greatest curvature, and straightened, the upper and lower segments will overlap, and the size of this overlapping triangle will give an adequate idea of the size of the wedge to be removed.

Let us return to the operation. The extent of the base of the wedge is marked off by two parallel transverse grooves, made with the chisel and mallet,—not the osteotome, but a chisel with bevelled edge,—and after this the wedge is taken away by a series of workmanlike chippings, with the exception of the hindmost remnant of its apex, which is snapped off. Some surgeons advise the removal of Esmarch's bandage at this stage of the operation; but it must be remarked that this leads to great and unnecessary loss of blood, a serious matter in children. It is safer to tie those vessels the cut lumina of which can be recognized by sight, and this will be facilitated by gentle compression and kneading of the vicinity of the wound, which will mark the location of even the smaller vessels by the escape of a drop or so of blood. The tendo Achillis is always to be divided by tenotomy.

After thorough irrigation, the segments of the tibia are brought together, a drainage-tube is inserted into the lower angle of the cutaneous incision, the wound is stitched up with catgut, and an aseptic dressing is snugly applied to the limb, including the foot and the knee-joint. Coaptation of the severed tibia is secured by a carefully-applied plaster-of-Paris splint. The drainage-tube should be left long, so as to project somewhat over the plaster cast. When the plaster has hardened sufficiently, but while it is still moist,

an ample fenestra is cut out around the drainage-tube, until the aseptic gauze dressing is exposed to view. Then the tube is cut off short, transfixed with a pin, and its end well enveloped in a generous bunch of iodoform gauze, which is snugly bandaged down to the splint, so as to exercise adequate pressure upon the underlying tissues for the prevention of local œdema.

The limb is now elevated, and, Esmarch's band being removed, digital compression of the femoral artery over the ramus of the os pubis is practised for five or ten minutes, or until the hyperæmia caused by the vasomotor paresis has disappeared. At first the toes become deeply flushed; as soon as this flush has given way to the normal pink color of the skin of the toes, compression of the femoral artery may be relinquished. An elevated position of the limb, however, should be maintained for an hour or two afterwards.

If the course of the healing be normal, which will be manifest by the absence of septic fever and local pain, the drainage-tube can be exposed and withdrawn on the third day after the operation, and this can be done without disturbing the deeper dressings. The fenestra is filled up with a mass of iodoform gauze as before, and the dressings are not interfered with till after a fortnight, when the plaster splint is removed, the limb is redressed, and another splint is applied, to remain *in situ* until the time of presumable consolidation has arrived.

Should septic fever, with much sickness and dejection, chills, and unusual local pain, point to an infection of the wound, a sufficient quantity of the dressing should be forthwith removed from the fenestra to expose it and to enable the surgeon to form an idea of its condition. The removal of a few confining stitches will often be sufficient to reduce tension and to improve drainage. A moist dressing, covered with a suitable piece of rubber tissue, is to be applied to the wound, and is to be changed at least once a day till the discharges become sweet and scanty. The edges of the fenestra are to be lined with strips of adhesive plaster and coated with several layers of alcoholic shellac solution. But finally the plaster will become foul, and will have to be removed, when the limb is to be subjected to a thorough purification before a new dressing and plaster splint are applied.

(d) *Flat-foot*.—For the sake of completeness, it may be mentioned that in severe cases of pes valgus in adults,—a deformity universally accepted to be rachitic or quasi-rachitic,—where milder and ordinarily successful methods of treatment have proved ineffectual, cuneiform osteotomy of the tarsus has been performed with marked success. Without reference to the joints, a wedge, having its base on the inner margin of the planta and its apex on the outer margin of the dorsum, is removed from the foot by means of the chisel and mallet, until an approach to the normal arch of the foot can be brought about, and maintained by the apposition of the cut surfaces. The size of the wedge is proportioned by the degree of deformity to be cor-

rected. The wound is to be managed as in other cases of cuneiform osteotomy. Usually ankylosis of the opposite bony surfaces and a marked functional result can be achieved. This operation is rarely, if ever, indicated in pes valgus of children, and hence need not be treated in this volume to such an extent as its importance otherwise would demand.

Tarso-osteotomy, simple or cuneiform, is occasionally required for the correction of aggravated and rebellious forms of another, though non-rachitic, deformity,—namely, *club-foot*. But as this subject has received adequate treatment elsewhere in this volume, it may suffice to say that, in conformity with the nature of the trouble, the base and apex of the wedge to be removed occupy exactly opposite relations to those in the operation for pes valgus. That is, in club-foot the base of the wedge is to be where the apex is in splay-foot, and *vice versa*.

# MECHANICAL TREATMENT OF DEFORMITIES OF INFANTILE PARALYSIS.

BY E. G. BRACKETT, M.D.

---

THE mechanical treatment of deformities arising from infantile paralysis, irrespective of the part of the body affected, is to be guided by the time the affection has existed, the amount of impairment of muscular power, and the degree of deformity which has occurred. On this basis of treatment the cases may be divided into three classes :

1. Those in which the treatment is directed only to the prevention of deformity.

2. Those in which deformity has occurred, but in which this deformity can be overcome by a reasonable amount of force.

3. Those in which surgical aid is necessary to overcome the existing distortion.

The deformities accompanying this affection are mostly, if not entirely, the result of mechanical forces, and occur slowly with the growth of the patient. The deformity is usually maintained by the adaptability of the muscles to the positions which are allowed to be assumed, as has been shown by Volkmann, and the structures, therefore, which oppose the reduction of the deformity are the muscles and the ligaments.

A great majority of cases are not brought to the surgeon for treatment until considerable atrophy and deformity have taken place, but inasmuch as these distortions occur after a time when a perfect development has begun or been attained, the deformity is but little dependent on bony change, except in severe cases of long standing where a considerable growth has occurred during the existence of the deformity. Therefore, when the part is held by these contracted structures, mechanical treatment must often be preceded by division of the opposing structures, unless the part can be brought into its proper position by ordinary manipulation.

Since the essential cause of these deformities is the lack of power of certain muscles or groups of muscles, this etiological factor must be borne constantly in mind in the course of correction, in this respect differing from the congenital cases, in which the muscular structures are nearly or quite perfect, and after correction may be of service in maintaining a normal position.

The length of time that it is necessary to continue treatment will depend on the degree of paralysis and on the age of the deformity, but, in general, when there is considerable weakness the foot must receive attention until the period of growth has been passed, or later if any tendency to deformity is then manifested.

The most important class of deformities from this cause demanding treatment are those of the foot. Considered in this paper are pes equinus, pes varus, pes valgus, and pes calcaneus, as well as deformities of the knee, the hip, the back, and the upper extremity.

**Pes Equinus.**—Of this variety of distortion there are two principal characters, which are found singly or combined, and consist of a flexion of the whole foot at the ankle-joint, or of the tarsus on itself. Of the former, particularly, all degrees are met with, from a right-angle contraction, to a condition in which the dorsum of the foot forms a continuous line with the leg, and in severe cases the toes may be directed backward and locomotion take place on the dorsum. In the other class the posterior part of the foot may be in nearly a normal relation with the leg, although the motion in the ankle-joint is much restricted, but the foot presents a more or less sharp curve opposite the arch, caused by a flexion at the medio-tarsal or tarsometatarsal joint. This deformity is much more noticeable on the inner than on the outer border.

The relation of these to a very slight deformity caused by a contracted condition of the fascia has been shown by Fischer,<sup>1</sup> and they have been called by him talipes arcuatus and talipes plantaris. He considers them to be due to early transitory paralysis, perhaps not infantile, after which the growth of the fascia was not proportionate to that of the rest of the foot. They are essentially the same as the affection described by Shaffer as non-deforming club-foot.

The advisability of any treatment in slight degrees of simple equinus showing no tendency to increase, and accompanied by shortening of the leg, should always be considered. It compensates the loss in length, is not more unsightly than a high sole, and allows a more natural use of the foot and leg, which must result after the period of growth in a better development of the limb.

Whenever the contraction of the tendo Achillis prevents the forcible restoration of the foot to a right angle, it is doubtful if it is wise to attempt the reduction of the deformity by mechanical means alone, unless the condition has existed for but a short time. The risks from tenotomy are so slight, and the accomplishment of the object is so thorough, that it must be given the choice except in occasional instances; while the use of apparatus requires the expenditure of much time and patience for the accomplishment of but little.

But in cases requiring interference other parts of the foot need atten-

<sup>1</sup> Lancet, January 26, 1889, *et seq.*



tion, and particularly the sole, when there is deformity situated in the middle of the foot. In extreme cases, where the foot forms nearly a continuous line with the leg, division of the deep flexor tendons may be necessary, but should not be done until forcible straightening has been tried, as the amount of shortening which accompanies this depression of the anterior part of the foot is very slight, and the deformity usually yields remarkably

FIG. 1.



in this direction. As an example of this is shown Fig. 1.<sup>1</sup> The foot in this case yielded to the Thomas wrench, and division of the tendo Achillis only was necessary. But when there is sufficient contraction of the plantar fascia to prevent the foot from being brought into a normal position by ordinary force,

division or replacement by forcible correction is advisable. Osteotomy in these cases of paralytic deformity must be considered as an operation rarely necessary. Very many would yield to the slow process of gradual replacement by repeated application of stiff bandages, but the method is not sufficiently advisable to be more than mentioned, and the remarks in reference to forcible straightening apply only to the surgical treatment which may be necessary before the mechanical can be begun.

Among the appliances for forcible correction by gradual reduction is that of Stillman, shown, with the manner of applying it, in Fig. 2. After

FIG. 2.

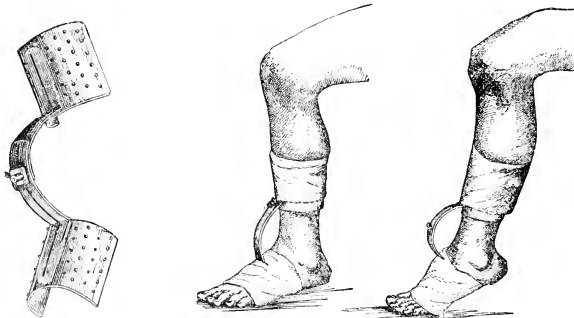

the proper position has been obtained, retentive apparatus will be necessary, as after correction by other means.

Mechanical treatment after operation consists purely in the retention of the foot in as nearly a normal position as surgical treatment will enable it to be brought: in fact, mechanical treatment in all of these cases may

<sup>1</sup> Used by permission of Dr. H. L. Burrell.

be considered as beginning where surgical treatment ends. The tendency of the foot when left to itself must be borne in mind, and the apparatus applied with the aim of preventing this, and, if this is successful, we may be confident that no permanent deformity will occur.

For most cases of this class, as well as of varus, the best form of retentive apparatus is the Taylor club-foot shoe, which possesses the advantage

of being easily applied, and, as it can be worn inside an ordinary boot, is not unsightly. This well-known appliance (Fig. 3) scarcely needs description, but a few of the important particulars of its application in these deformities may be briefly noticed. The sole-plate should extend from the extremity of the heel to the cleft of the toes, following more or less closely the contour of the outer border of the foot. The upright should extend on the inner side of the leg nearly to the knee, and be there secured by a strap passing round the calf. Extension at the ankle is checked at any desired point by the stop-joint, and this usually is at a right angle. In applying this shoe the foot should

FIG. 3.

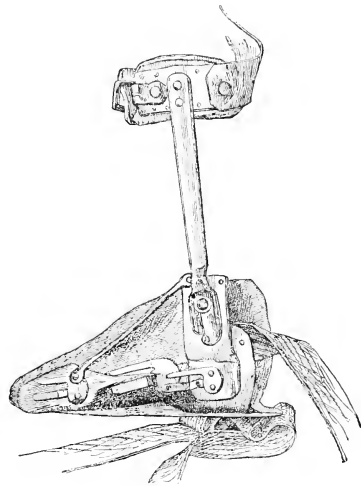

first be strapped to the sole-plate, with the upright bent forward, and this must not be brought into position on the leg until the foot has been secured. This is especially important with the varus deformities.

When the deformity is that of a flexion at the ankle-joint, it is necessary that the heel should always be in contact with the bottom of the shoe. When the foot presents the angle at the arch, it is important to keep the anterior part of the foot on its normal level. This must be done by pressing the centre of the foot firmly down to the plate while securing the straps.

For the slight degrees of deformity designated by Fischer as *talipes arcuatus* and *talipes plantaris*, treatment is purely the correction of the deformity which is kept up by the contracted fascia, and which may be overcome either by surgical or by mechanical means. After correction mechanical appliance is rarely necessary, as the muscles have usually so far regained their strength that the deformity does not recur. The foot should be watched, however, for such tendency, and treated if necessary.

The same object may be accomplished by mechanical means by repeated application of the plaster bandage with this contracted fascia on the stretch. Among the advantages which this method possesses, the rest which is neces-

sitated is an important one. There is frequently little or no diminution in the size of the muscles, but the foot becomes tired much more easily than its fellow, and at such times a limp is frequently developed, apparently due to the tension of the muscles which is necessitated by the condition of the foot. Shaffer advises the gradual reduction by the use of the extension shoe.<sup>1</sup> Its full description would demand too much space for this article, but its construction is based on the principle of imitating the natural centres and directions of motion of different parts of the foot, and the force applied is that of traction. It is intended for any form of equinus, but the method of its employment in the non-deforming club-foot differs somewhat from that in ordinary equinus. Complete description will be found in the article to which reference is given.

Many other forms of appliance have been devised and are still used, but preference has been given to the Taylor shoe, as it is both easy of application and efficient. The elastic muscles of Barwell have had extensive use, but have never found much favor here. If they are stiff enough to overcome the deformity and hold the part in place, they accomplish no more than unyielding apparatus which can be accurately regulated. The idea of substituting elastic tension in place of the weakened muscles was carried to a high degree of perfection by Duchenne, who not only used delicate springs for separate muscles, but also imitated their insertion-points. It is doubtful if this elaborateness has any practical value, and the plan followed by Barwell in so placing this elastic extension as to bring the foot into the desired position without reference to the insertion of the natural muscles is better. The artificial muscles are secured to the limb by means of adhesive plaster. The special forms which are used for the different types will not be here enumerated, but they are such as to imitate the direction of the force used by the hand in correcting the abnormal position.

The importance of wearing a support at night in the equinus as well as in the equino-varus deformity should not be overlooked. The pressure of the bedclothes is in a direction to maintain and to exaggerate the tendency to deformity, and this influence is undoubtedly an important etiological factor in many of the slightest cases. It is by no means necessary that the walking appliance should be worn, but any form which will prevent the foot from being pressed into its unnatural position will be sufficient. For both the pure equinus and the equino-varus the same apparatus will be useful. A posterior wire splint, consisting of a long narrow frame wide enough to support the leg comfortably, extending from the upper third of the calf to the end of the toes, and bent to a right angle at the heel, is an efficient appliance. A covering is stretched between the wires, and the foot is strapped or bandaged to the frame.

This same principle is carried out by supports made from tin or wood, which are equally efficient, but more cumbersome.

---

<sup>1</sup> New York Medical Journal, March 5 and 12, 1887.

**Pes Varus.**—Usually this form is associated, as are the congenital forms, with equinus, but it may occur independently; and existing in a slight degree, shown only by a dropping of the anterior part of the foot and a slight inversion of the toes when the foot is hanging and at rest, this forms a common condition. But this position in time tends to become permanent by the contraction of the plantar fascia with the shortening of the muscles, and an equino-varus results.

As the distortion increases, the ball of the foot approaches the heel at the same time with the rotation of the fore part of the foot, and, as this inversion occurs principally at the medio-tarsal articulation, the locomotion is chiefly on the fourth and fifth toes and the ends of their metatarsal bones. It is evident that from this a severe distortion may occur by a further increase in the same direction.

One form of varus, due principally to weakness of the peronei, often is seen, in which there is little or no tendency to permanent deformity, except a slight eversion of the foot at the ankle-joint. The foot can be thrown forward so as to bring the foot to the ground, but without this effort the foot, which when at rest hangs loosely with the toes pointing almost directly downward, first comes to the ground on the anterior part of the outer border, and, as the weight of the body is thrown on the leg, is rolled over, so that the weight is borne entirely on the dorsum. This happens when the patient walks quickly or carelessly, but when attention is given the foot can be placed flat on the ground. In this way the abnormal position does not become habitual, and contraction with permanent deformity does not occur; but as the foot is used, this malposition is assumed more and more, until it may become usual during the act of walking.

The varus element rarely requires more than mechanical treatment, unless the deformity has existed so long, and the inversion of the toe and of the whole foot has been so severe, that contraction has occurred, in which case either division or forcible correction would be indicated. Probably most cases would yield to the slow stretching process; but this requires an unnecessary amount of work and patience on the part of both surgeon and patient, and much loss of time. If, however, the deformity yields to forcible manipulation, correction by mechanical means may be undertaken.

In restoring the position of the foot, whether by operation or by mechanical measures, the inversion of the fore part of the foot should first be corrected, next the rotation, and finally the equinus. If operative measures are necessary, the choice of method must be decided by the individual case, but two surgical aids to a successful or at least a speedy mechanical treatment are commonly valuable,—section of the plantar fascia and section of the tendo Achillis. More resistance is given by these two structures than by any other which it is necessary to overcome, and it is not wise to spend too much time in a slow stretching process.

Shaffer strongly recommends the use of the lateral traction shoe, which embodies the same principles as the traction shoe, but is applied to the

varus deformities. By this the foot can be gradually forced into position, and this force applied in whichever direction and in whatever amount may be found necessary at different stages of the correction.

For retention after the deformity has been overcome, and for cases where no distortion has occurred, the Taylor club-foot shoe will be found adapted in the majority of instances. If equinus is associated with the varus, a stop-joint at the ankle will usually be necessary, so placed as to prevent plantar flexion beyond a right angle. It is of great importance that the shoe be correctly applied, as otherwise the foot will not be brought into proper position, and the apparatus will be ineffectual. The foot must be pressed firmly against the sole-plate, with the upright brought forward, lying obliquely across the leg. The foot is then secured by the straps, and finally the upright is forced back into position. By this motion the varus and equinus are corrected. Applied in this way it acts both as a correcting and as a retention appliance. Occasionally, when there is shortening of the leg, this stop may be omitted, as the slight amount of equinus compensates this, improves rather than injures the gait, and adds to the comfort of the patient. When there is but a slight inversion of the toes, the apparatus may be made very light, with a simple joint at the ankle; and the same is true when this is associated with a moderate degree of rotation of the fore part of the foot.

In many of these cases of slight degrees of deformity it is a question to be carefully considered whether any apparatus should be worn during the day; but the importance of some support at night cannot be too strongly

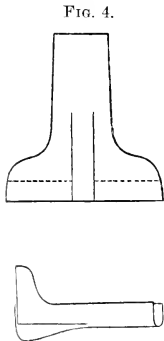

urged, and the recurrence after correction in many cases and the persistency in others are often undoubtedly due to the pressure of the bedclothes against these weakened muscles. Frequently support during the day may be dispensed with when the foot is not brought into an abnormal position while bearing the weight of the body, and the natural use of the healthy portion is then not restricted by the apparatus. The form of the appliance worn at night is not important, so long as the foot is kept in position. The wire splint can be used, or a tin shoe, which can easily be made by any one. A piece of tin is cut into shape and bent and riveted in the manner shown in Fig. 4. The dotted line indicates the part which is bent inward to make the sole. The upper portion is curved to fit the

calf, and the small tongue is turned backward to remove the bearing from the heel. It is important to have this concavity deep enough to hold the heel without pressure.

**Pes Valgus.**—When this exists to a slight degree, forming a flat foot only, with no other distortion of the foot, rarely will more than an adequate support to the arch be required. The eversion of the foot is conse-

quent to the giving way of the arch, and the position of the foot closely resembles that in the so-called static flat-foot. This deformity existing alone is usually slight, being due to slight weakness and seldom seen until long after the original trouble; but it is by no means always due to this cause. When the arch is maintained in its normal condition, sufficient correction is obtained. The most practical form for this support is the plate devised by Dr. Whitman for flat-foot, which gives an efficient support to the foot, and interferes to a slight extent only with the movement of the articulations of the tarsus. This is fully described in the article on club-foot, and needs no further reference here.

Elastic extension has been used with this as with the other forms, among which is the ingenious contrivance of Barwell, the principle of which is shown in Fig. 5. The arch is supported by means of the webbing which is wound around the foot and secured above, with the intervention of elastic bands. The force, however, which can be borne as a constant pressure is so far exceeded by the amount necessary to hold the foot while in use that it cannot be uniformly serviceable.

The more commonly seen deformity of this class is a condition in which, added to the giving way of the arch, there is a marked eversion of the whole foot at the ankle-joint. The inner malleolus is abnormally prominent, and in proportion to the amount of eversion is made to approach the ground by the superincumbent weight. When at rest, this deformity frequently nearly disappears, but with the foot hanging the toes are found to droop more than on the well side. The deformity is an unfortunate one, as the use of the limb strongly tends to increase the distortion. Associated with this there is often considerable weakness of the peronei, and in walking the toe drags and is turned outward.

The object in the mechanical treatment of this deformity is both to support the arch of the foot and to prevent the eversion at the ankle-joint. In many cases a well-adjusted support to the arch is sufficient, this preventing the eversion of the foot, but a simple plate is not enough. The object may be accomplished by a band of leather secured to the inner surface of the shoe along its outer border, passing beneath the arch of the foot to above the outer malleolus, where it is fastened to a short upright connected with the shoe.

An effectual apparatus is made by combining the plate used by Whitman with an outside upright provided with an ankle-joint and connected with a plate fitting the outer border of the foot. To this piece the sole part is firmly attached by leather, which covers the inner side of both, and is continued up over the dorsum of the foot, from the inner side, by straps which buckle to the upright and to the plate. This possesses the advantage

FIG. 5.

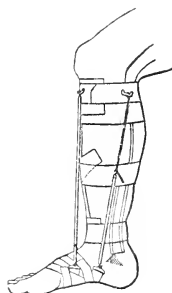

of a firm support at the weakest part, and this support is moulded to the form of the foot.

When the eversion of the foot predominates, and particularly if there is but little displacement of the arch, as is shown in Fig. 6, the sole-plates are of no benefit. In these the most commonly used appliance consists of an upright on the outer side of the leg, fastened to the sole of the boot, and extending to the upper third of the calf, with a joint at the ankle. A triangular piece of leather is secured to the boot and to the upright, so that its centre is over the inner malleolus, with one point attached to the sole of the boot near the inner edge, and the other two connected with the upright by straps, one passing behind and the other in front of the ankle. As the tendency is to a lateral displacement inward of the ankle-joint when the weight is borne on the leg, this arrangement sufficiently prevents

FIG. 6.



this movement, and when the leg is free from weight the deformity is so much less that the straps are not tight enough to cause discomfort.

The same principle of support is carried out more effectually by the Taylor club-foot shoe. This is essentially the same as the usual form which has been described, with the upright placed on the outer side. The inner edge of the sole-plate is made to conform to the shape of the inner border of the foot, or this plate may be arched to fit the natural arch. The foot is secured to the apparatus in the usual way, with straps and buckles.

**Pes Calcaneus.**—This must rank among the rare deformities resulting from infantile paralysis. Cases of pes calcaneus are usually of a severe type, are accompanied by a very great loss of power, and come under observation only after a long lapse of time, during which there has generally been complete neglect. There is, then, in the majority of cases, when first seen, a decided valgus, so that the deformity should properly be called calcaneo-valgus.

The benefit to be derived from mechanical treatment alone in the severe cases is in the direction of giving comfort to the patient rather than of improving the condition of the foot. Surgical measures can diminish the deformity, but firm retention is then necessary. For this the Taylor outside shoe, with a stop-joint to prevent extension beyond a right angle, is an efficient means. In the simple cases in which the deformity is that of calcaneus alone, this will be found sufficient, but in the severer forms it will be found better to mould the sole-plate to correct the valgus. The combination of the Whitman plate and the outside upright will meet the requirements in most cases.

**Knee.**—The deformities of the knee which require treatment are chiefly a condition of hyperextension and one of permanent flexion. These, and

particularly the former, are the result of a very marked paralysis of the leg while the thigh is but little affected, or of a very general paralysis of the whole leg. The treatment of these two conditions is essentially different, and the latter will be considered later. As the muscles which control the hip-joint are essentially normal, support may be had from the thigh. As in this class of cases the weight cannot be supported when the knee is bent, the leg is thrown into full extension before the foot is put to the ground, and this position is assumed with each step in walking.

For this simple hyperextension of the knee-joint, or for cases in which the loss of power is chiefly below the knee, without any deformity, the caliper-splint forms a simple means of support. A steel wire passes on either side of the leg and beneath the foot, when it goes through a socket which is secured to the shoe. The inner wire should extend nearly to the perineum, the outer a little higher, and these two are connected by a plate which passes behind the leg and by a broad strap in front. A leather band secured by the four corners and passing behind the knee will prevent the hyperextension, and a pad over the knee is usually necessary. As a rule, further retention is not required, but, when necessary, may be applied to individual cases.

Another form, less cumbersome, but scarcely more efficient, is shown in Fig. 7. It consists of an outside support jointed at the knee, with anterior and posterior plates to hold the leg in the position required. It possesses the advantage of allowing the patient to bend the knee while sitting, the joint being locked by the drop-catch when the patient stands with the leg extended. If with the affection of the knee there

is associated a deformity of the foot, the splint may be connected with a club-foot shoe which is worn inside the boot; but otherwise it is better to connect the splint with the shoe and with a simple joint at the ankle.

A very ingenious splint has been used by Walsham<sup>1</sup> for cases with this distribution of the paralysis. Its object is to allow the thigh-muscles to control the motion of the leg. The apparatus consists of an outside upright jointed at the hip and the knee. By two additional strips connected with these two joints by levers, the motion of the leg can be governed. When

FIG. 7.

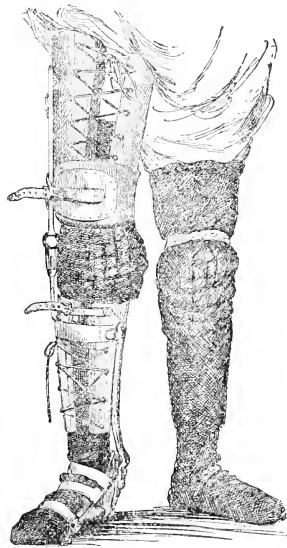

<sup>1</sup> Lancet, July 28, 1888, p. 158.



the thigh is extended, the leg is held straight, and is not released until the thigh is flexed. The Walsham splint has the particular advantage of allowing motion at the knee during the act of walking.

When contraction at the knee exists, it is usually in those cases where the leg has had little or no use, and motion is free to a certain point, where it is arrested by the shortened hamstrings and the contracted capsule. By a slow process of gradual reduction or extension the contraction may be overcome; but surgical means attain this object with the loss of but little time. Retention is then accomplished as in the other cases.

*Knock-Knee.*—Two etiological factors have influence in the occurrence of this deformity in infantile paralysis,—the direct weakness of the muscles, and the positions which are assumed in the efforts to use the leg, when the paresis involves some other part than the knee, as the foot. When it is due purely to the latter, and no bone-malformation has resulted from long continuance, treatment directed to the foot only will be required for the correction of this part. When it results from weakness of muscles of the thigh or about the hip, and the position which is assumed in the effort to maintain equilibrium tends to develop this deformity, treatment must be directed to the impaired parts primarily. If bone-changes have taken place, they must be treated on the general principles of the correction of knock-knee.

*Hip.*—Deformity at the hip is perhaps always associated with paralysis involving the whole leg and when but little regeneration has taken place. It is caused by a contraction of the sartorius and the fascia of the thigh, which produces flexion at the hip-joint. The leg is small and flail-like. When the attempt is made to extend the thigh, it is arrested by a tense band which is seen extending downward from the anterior superior spine. When left to itself, the leg falls outward and then becomes flexed, so that the whole leg rests upon its outer surface. The knee-joint is usually lax and permits hyperextension, and the foot has a tendency to either varus or valgus deformity. The use of the limb may be practically lost, or the patient may retain considerable power in certain directions.

It is the amount and character of this control that must be considered in deciding what form of support is to be given. With judicious selection of apparatus a considerable improvement in the usefulness of the limb can be obtained, even in cases of long standing, when they can be had during the periods of growth, and by affording additional use of the limb we can expect the adult growth to be reached with less atrophy and shortening, which are undoubtedly more directly in proportion to the disuse than to any other cause. The early application of apparatus is directed more to the prevention than to the correction of deformity, but the form of support used does not differ essentially in either case.

The contraction at the hip requires operative interference if great enough to prevent the patient from standing erect with both feet flat on the ground. Division of the superficial structures in the anterior part of the thigh,

either by subcutaneous section or by open incision, will usually accomplish this, although it will not entirely overcome the deformity. The contraction remaining is maintained by the deep structures, principally the tendon of the iliacus and psoas and the capsule, the division of which involves risk which would be justified by necessity only.

The most difficult cases to treat are those of paralysis involving both legs, with loss of power so great that the patient is unable to walk or stand alone. Rarely are both limbs paralyzed to an equal degree, certain movements being generally possible with one, so that it can be used to support the body when placed in the proper position, while the other is quite lax. Even those children who have never walked can, with the aid of properly-applied support to both legs and with crutches, be enabled to go about alone. Although their locomotion is slow and awkward, it is far preferable to the utter helplessness of the other condition.

Fig. 8 illustrates the form of apparatus which may be used in these cases. It consists of an upright attached to the sole of the boot and extending above the trochanter.

When a double splint is used, it is best secured to the pelvis by a broad leather band encircling the waist and connected to it by either a simple hinge or a ball-and-socket joint; but when the splint is single, it is best secured by a steel band which nearly half encircles the pelvis. The knee-joint is provided with a stop, which keeps the leg extended while walking, but allows the knee to be bent while sitting. The thigh is firmly held by a posterior and an anterior plate, but the leg is sufficiently held by a calf-plate and a strap. When this apparatus is necessary for one leg alone, there is usually no need for additional aid by a crutch or cane. With double paralysis, crutches are almost essential, and progression may be in one of two ways: either the weight is borne on both crutches at once and both feet are swung forward, or one crutch is put forward and the foot on the opposite side is then swung or dragged forward, and the same movement is repeated by the other side. This manner of locomotion is usually practised when the paralysis is very extensive.

FIG. 8.

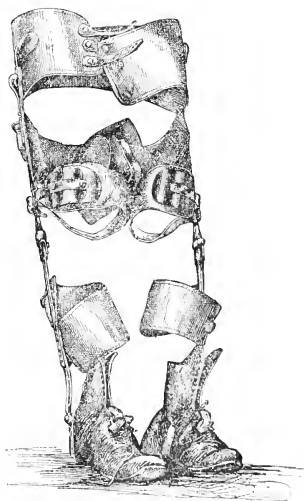

**Spine.**—Lateral curvature due to purely unequal action of muscles of the trunk is not of frequent occurrence, but as a result of inequality of the length of the leg it is very common. When this shortening is due to

infantile paralysis, there is associated with it a loss of muscular power, which adds another influence to the distortion besides the simple disturbance of the normal plane of the pelvis.

As to the form of support in these cases, no special directions are required beyond those for the general treatment of lateral curvature, but some kind of appliance is necessary, at least during the growing period, to maintain, so far as possible, the normal shape of the trunk, since the weakness of the muscles is an ever-present influence towards a distortion. Perhaps the most thorough support is given by a close-fitting leather jacket moulded over a cast of the patient which was taken while he was as nearly as possible in the correct position.

**Shoulder.**—The principal deformity affecting the shoulder is caused by a paralysis of the deltoid particularly, which results in a kind of subluxation of the head of the humerus. In addition to the disability, this paralysis is unfortunate, as the unequal use of the arms and their weight tend to produce a dorsal curve; but, happily, it is rarely met with. The affection is hardly amenable to mechanical treatment, other than that of supporting the arm by firm bandages, but these all interfere very considerably with the use of the joint.

# AMPUTATIONS.

By WILLIAM BARTON HOPKINS, M.D.

---

IN considering the conditions which warrant the performance of amputation in children, and indicate this radical measure instead of some conservative operation, their constitutional peculiarities, their nutritive functions, the quality of their general vitality, and the activity of their local circulation and nutrition should be carefully compared with those of the adult. While physically they are more deeply affected by shock than adults, psychically they are far less susceptible. The dread of losing a limb, and with it possibly the means of obtaining a livelihood, which often is such a depressing factor in adults, and which, as every surgeon has observed, often retards reaction, does not obtain with children. I recall an incident strikingly illustrating this. A small boy in hospital cheerfully said to me, "Eddie was operated on to-day, and I am going to have my leg off to-morrow." Profoundly influenced by shock, children react quickly and often violently. Anæsthetics, which usually act particularly well in them, have to be given with great caution when they are suffering from shock. They feel the loss of blood relatively more than adults, and I incline to the belief that they are more susceptible to sepsis. Their processes of repair in an injured or a diseased part are very active, and their bones are soft and vascular. Fewer limbs need be amputated for injury in children, and much more extensively damaged tissue can be saved and utilized in them than in adults. Amputation, too, is much less frequently required for disease of the bones and joints in children, as in them excisions, resections, and other conservative means afford the best possible prospects of success.

The changes in the skeleton which depend upon the growth and development of bone also have an important influence on amputations in certain regions. The most important of these is the activity of the growth of the epiphyses. In an adult the value of retaining the head of the humerus in an amputation at the shoulder-joint, for example, would hardly be considered, while in children the result following this conservatism fully warrants its being attempted. Figs. 1 and 2 represent two children operated upon by the writer, both thirteen years of age. In one, amputation was done at the shoulder-joint; in the other, the head of the bone was retained, along with a small portion of the shaft. At the time but little difference appeared between the two stumps; three and a half years later,

however, the contrast, as shown in Figs. 3 and 4, had become very marked. The girl's shoulder-joint, Fig. 3, presents the wasted, helpless appearance

FIG. 1.



Stump after amputation at the shoulder-joint, in a girl of thirteen years.

FIG. 2.

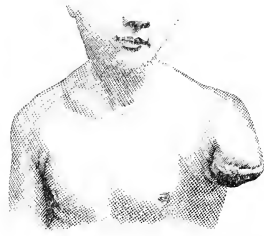

Stump after amputation, where the head of the humerus was retained in a boy thirteen years of age.

which characterizes this stump, while the boy's shoulder, Fig. 4, is full and round, and he can help himself with it in numerous ways.

FIG. 3.

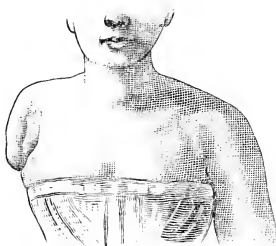

Condition of stump three and a half years after shoulder-joint amputation (see Fig. 1).

FIG. 4.

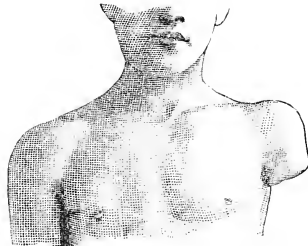

Stump three and a half years after amputation near the shoulder-joint, little more than the head of the bone having been retained (see Fig. 2).

Epiphysial growth, while it may be made subservient to the function of

a stump, very frequently, when the flaps have not been made sufficiently large to accommodate the increased size of the bone, may become a cause of mischief, producing the condition of conical, irritable stump, which requires re-amputation. Fig. 5 represents a stump of this kind, photographed from a boy at the Pennsylvania Hospital, three years after an upper-arm amputation. The bone in him

FIG. 5.

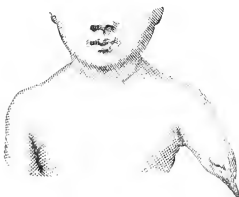

Conical stump in a boy of about six years, three years after amputation of upper arm. The bone seemed to be covered only by a scab.

strongly indicates that the humerus was thrust out by its growth, and not left exposed by the recession of sloughing flaps.

TECHNIQUE OF THE OPERATION.

The instruments and apparatus needed are very simple and few. They should be properly prepared and kept immersed in antiseptic fluid as in other operations.

An ordinary razor is required, to shave the hair from the limb at the site of amputation and to a considerable distance above it. It is better to shave off even the delicate growth of hair in children; done carefully with a keen-edged instrument, the risk of the skin being made thereby a medium for the absorption of septic matter is not to be considered.

For operations by transfixion a straight knife (Fig. 6), with a rather

FIG. 6.



Long amputating knife.

delicate blade, one-third longer than the diameter of the limb at the point of amputation, is the only knife needed, except a scalpel, unless the amputation is of the forearm or leg, when a catling of very moderate length is also required to divide the tissues between the bones. For flap operations where the tissues are to be divided from without inward a much shorter knife will do more rapid and certain work. For the fingers and toes a Neill's amputating knife, which is a cross between a scalpel and a straight bistoury, is very useful.

The surgeon should be supplied with an ample number of catch artery-forceps, certainly not less than a dozen for an ordinary amputation. A two-tailed retractor for a single bone, and a three-tailed retractor for a double bone, should be made of unbleached muslin carefully boiled and rendered

FIG. 7.

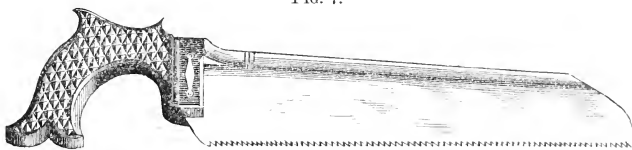

Amputating saw.

aseptic. A saw (Fig. 7) very similar to that used in the carpenter's mitre-box is applicable for the division of all the larger bones; for the smaller bones a very delicate saw (Fig. 8), with a narrow spine to its blade, will usually be found to leave a nicer surface than when the division has been accomplished with bone-forceps. These (Fig. 9) should always be at hand, however, to cut off any little splinters or uneven edges of bone left by the saw.

FIG. 8.

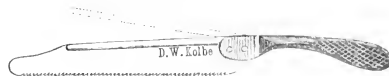

Saw for small bones.

Two or three long needles should be provided, in order that the approximation of the flaps may not be delayed while they are being threaded. The

FIG. 9.



Bone-forceps.

needle I prefer (Fig. 10) has a lance-shaped point. In introducing a needle and carrying through the material with which it is armed, two distinct movements are executed,—namely, thrusting

FIG. 10.



Flap-needle.

the needle into the tissues, and drawing it out on the other side. These may well be called the first and second

positions. In the first position the needle is held between the thumb and index finger and driven in by the third; in the second position the shank of the needle is seized by the wet, slippery fingers of the operator and drawn the rest of its length through. In the first position all the force required is readily obtained, and it is with this object that the needle shown was constructed, its blade being sufficiently broad to cut an opening through which the suture can be readily drawn.

**Control of Hemorrhage.**—The control of hemorrhage is best accomplished by the use of the Esmarch bandage. To drain the limb of blood by elevation, as particularly advocated by Mr. Lister, employing only the circular band of Esmarch, is probably the most satisfactory way to employ it. The reactionary hemorrhage is certainly much increased by using the continuous rubber bandage, and causes increased delay in controlling general oozing, without saving for the patient much blood.

In using the circular tube or heavy flat band a word of warning will not be out of place. The nerve-lesions which from time to time have been reported as following the use of the Esmarch circular band will probably seldom occur if a simple mechanical proposition is remembered. One turn of this heavy elastic band around a limb, drawn only moderately taut, exercises a powerfully constricting force, and each succeeding turn almost doubles that of the preceding. In demonstrating this force I have not infrequently taken a number of turns with this band around a block of wood, with the result of making quite a deep furrow in it; and we all know how easy it is to cause very painful constriction of a finger by repeated turns of a small rubber band. Therefore, in applying Esmarch's constricting band, particularly to the soft, yielding tissues of children, great care must be exercised not to get too much pressure. Any one who has not experimented much in this matter will be surprised to find how little force it is necessary to exercise to arrest the pulsation in the principal artery, and with this

controlled there will be very little chance of leakage through any smaller vessels.

**Formation of Flaps.**—With a clear idea in his mind of the shape the flap is to be and the position it is to occupy, the surgeon enters the point of the knife straight into the limb at the opposite side from which he is standing, and, with firm steady pressure, carries it in an easy curve to the other side, dividing, if possible, all the tissues down to the deep fascia. If the flap is to be an integumentary one, it is to be rapidly dissected up by light touches with the point of the knife. The flap on the other side, if also tegumentary, is to be formed in a similar manner. If it is to be made by transfixion, the knife is entered at one of the angles already made, is carried behind the bone, its point being made to emerge from the other angle, and by a sawing movement it cuts through the tissues at the back in such a manner as to form a flap of the required length.

**Division of the Bone.**—All of the larger bones and usually the smaller ones are divided with a saw, which has already been described. Division of a single bone is accomplished in the following manner. Having selected the point which is to be divided, the knife is carried around its entire circumference, and the bone is made bare of periosteum in what is to be the track of the saw. The heel of the saw is made to bear lightly upon the bone, and, the surgeon directing its course with the thumb of the left hand, the instrument is drawn backward in order to cut a shallow slot. With the limb held very steadily both above and below the point of incision, the saw is made to travel slowly and evenly most of its length until the cut is almost completed, when a few short movements finish the division. When the bone is sawn nearly through, care must be taken not to press its distal extremity either upward or downward, but to give it just enough support to hold the weight of the limb; as in the former instance the saw will be pinched, through closure of its slot, and in the latter the bone will snap off, either leaving an ugly splinter or taking one out of the retained extremity of bone. I incline to the belief that the bone is usually sawn through too rapidly, the surgeon, if he is at all agitated, rather hastening to get through with this step of the operation. With the view of determining how hot bones can be made with the saw, I have sawn through fresh beef-bone with great rapidity, at the same time letting my saw become jammed a little, with the result of getting a decidedly burnt odor of the cut surface; and, as charred bone is exceedingly prone to become necrotic, I am not sure but that we may find in this the cause for the frequent necrosis of a delicate shell of bone corresponding with all or a portion of the sawn surface.

**Arrest of Hemorrhage.**—In all amputations the principal vessels can be tied before the removal of the tourniquet or other controlling appliance. In the larger amputations the open mouth of the main artery stands out clear and plain. It should be seized with the artery-forceps, and with the finger-tip isolated from its connections, not only in order to avoid tying with it any part of its accompanying nerve, but also because the action of



the ligature upon its coats will thereby be best accomplished. The catgut used should be chromicized sufficiently to last two weeks, and for a large vessel should be No. 3, for a smaller vessel No. 2, down to branches the size of a digital artery, for which No. 1 is appropriate. A double reef-knot should be made for ordinary vessels, and a treble knot for the femoral or brachial. After the tying, the surgeon seizes the free ends of gut with his left fingers, while he places his right thumb upon the knot in such a way that its nail shall act as a gauge for the assistant to place the blade of his scissors upon in cutting through the gut an eighth of an inch from the knot. The principal vein is then to be treated in a similar manner.

After removal of the tourniquet numerous small branches will make their presence apparent either by streams of blood or by points of dark clot. In the latter a little scraping should be done in order to coax them to bleed. If the patient's condition is good, it is well to delay for a while the approximation of the flaps,—that is, not to hurry with the closure of the wound,—as it is far better that reactionary hemorrhage should occur under observation than in the dressing.

General slight oozing may be arrested by the use of hot water applied with sponges at a temperature a little too high to be borne by the fingers. A much more efficient agent, however, is prepared chalk. This I have used in about a dozen and a half major operations in the past six weeks, and have been much gratified with its effect. It should be sterilized by heat and kept in a salt-pot. When the hemorrhage has been sufficiently arrested with ligatures, the chalk is freely dusted over the bleeding surface, and, after being allowed to remain two or three minutes, is completely washed off by the irrigating stream.

The effect upon muscular tissue was in the beginning a great surprise to me. It assumes a harsh, parched surface, looking and feeling as if some powerful irritant had been applied; the color changes to a dusky red, and the oozing ceases. There is no evidence, however, that any irritation has been caused, and I have failed to observe that primary union is in the least retarded by its application.

**Approximation of Flaps.**—In the larger flaps, it being important that no open space containing air should remain, it will often be found best to introduce two or more deep sutures half-way up to the base of the flap. These should be tied very loosely, so that they shall not interfere with the free circulation of the blood in the tissues included within them, their only object being to bring the internal surfaces of the wound into contact. Neat coaptation of the edges of the flaps is best accomplished by interrupted sutures of catgut, in a manner which will be described in treating of the several amputations. I prefer also giving the details of the dressing of each stump in its proper place, in order that the reader shall not be obliged, perhaps when hurried, to refer to these matters under another heading.

## SPECIAL AMPUTATIONS.

## UPPER EXTREMITY.

**Fingers.**—If the tip of a finger is cut off at a point not higher up than the middle of the nail, no operation need be done, provided the injury has been produced by a clean cutting instrument, as an axe or a knife. If the wound is a contused one, caused by cog-wheels or the like, it may be necessary to cut away the edges which have been destroyed. Should the lesion extend a little higher up, the distal phalanx becomes involved, and a sufficient portion of it must be removed to countersink it a trifle below the level of the surrounding tissues. At a point between the base of the nail and the distal joint, though clean wounds often cicatrize leaving a stump free from tenderness when no flaps have been made, it is generally desirable to make a sufficient attempt at flaps to effect partial approximation. So great is the vitality of the fingers, and so important is it that not a fraction of an inch should be unnecessarily sacrificed, that it is better to leave a wound not completely approximated than to remove good tissue in order to form perfect flaps. For the same reason it is always proper to amputate in the continuity of a phalanx rather than to go higher up in order to reach a joint.

Formal amputation at the joint of any digit, with the exceptions afterwards to be mentioned, is done by forming a short oval posterior flap with a long anterior. Amputations at the metacarpo-phalangeal articulations may also be practised by antero-posterior oval or by lateral flaps. At this joint of the middle finger a modified oval flap operation (Fig. 11) is often done. Entering the knife at the back of the joint, it is carried obliquely downward and forward and is made to encircle the finger and return to the starting-point by a single sweep.

After disarticulation the head of the metacarpal bone is frequently sawn off, particularly in cases where the individual is not obliged to do manual labor. The object of removing the head of the metacarpal bone is to make the deformity less noticeable, as it allows of closer approximation of the adjoining knuckles. Among the working classes in adults I do not advise this, as the strength of the hand is thereby somewhat diminished. In children, however, it is advisable. The same is true of amputation at the metacarpo-phalangeal articulation of the index finger. Fig. 12 illustrates an amputation of the index finger in a little girl operated upon by the writer, where the head of the metacarpal bone was removed simply

FIG. 11.

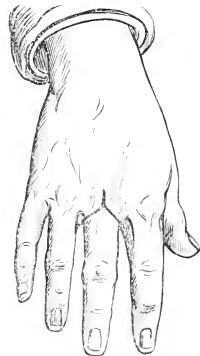

Incision for metacarpo-phalangeal amputation. (After Agnew.)

to improve the appearance of the hand. Fig. 13 is made from a photograph representing her crocheting, and so easy is the line from the middle

FIG. 12.

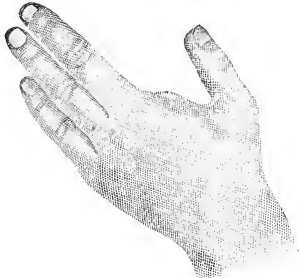

Result after amputation of the index finger, with removal of the head of the metacarpus.

FIG. 13.

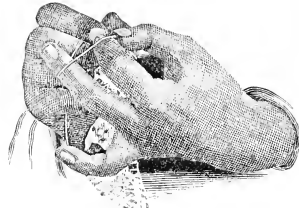

The same, doing needle-work.

finger to the thumb that it is at first sight difficult to realize that the index finger is wanting.

In amputating fingers it will be found very convenient to arrest hemorrhage by employing a rubber band, as the circular bandage of Esmarch. One of these little bands can readily be applied doubled upon itself often enough to give the requisite constriction, and it very much facilitates the performance of the operation, by keeping the tissues dry. Particularly is this the case when an amputation is done for disease of the bone, where it is important to observe to what extent the disease has involved the latter. After the amputation has been completed the band is removed, and the two arteries which will be found on the palmar surface at the inner and outer sides are ligated.

A small drain consisting of two or three strands of catgut is placed directly across the bottom of the wound. The latter is brought together by three or four interrupted catgut sutures. A delicate strip of protective is placed over the wound, the stump is dusted with iodoform, and a dressing of corrosive sublimate is made to envelop the stump; upon this a layer of corrosive-sublimate cotton is applied, covered snugly with a double thickness of oiled silk. The hand and forearm are retained to a palmar splint which has been comfortably padded with oakum and patent lint.

**Amputation of the Carpus and the Metacarpus.**—Amputation of the thumb and its metacarpal bone is performed by entering the knife at the base of this bone and carrying it straight downward on a line corresponding with the junction of dorsal and palmar skin until the metacarpophalangeal joint is reached, where the knife is made to encircle the digit obliquely and return to the straight incision (Fig. 14), as in the amputation of the middle finger just described. The bone is then dissected out, disarticulated at its carpal articulation, and approximation of the flaps is readily

and perfectly accomplished, leaving behind all the muscular tissue composing the thenar eminence. With this stump a certain degree of opposition to the fingers remains.

FIG. 14.

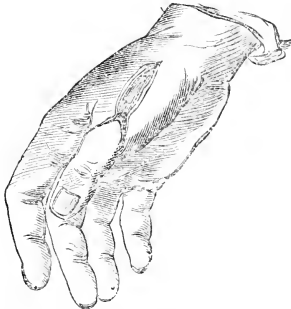

Lines of incision in removing the thumb with its metacarpal bone. (After Agnew.)

FIG. 15.



Stump after removal of a wedge-shaped piece from the central portion of the hand. (From a cast in the writer's collection.)

Where the injury has involved some portion of the hand which precludes the performance of any formal operation, it is perfectly proper to cut away with the saw or the forceps all bone which is hopelessly damaged or which prevents approximation of the soft parts. In Fig. 15 may be seen the result of one of these irregular operations, done by the writer at the Episcopal Hospital. The boy's fingers were caught in cog-wheels, the damage extending well into the middle of the hand. The operation done here consisted in sawing out, without the least regard to joints, a wedge-shaped portion of bone, including parts of the carpus and metacarpus, the apex of the wedge being very close to the wrist-joint. The outer and inner portions of the hand were brought together, with the result of giving the boy, who worked in a mill, a strong and useful hand.

In amputations of the metacarpus along with portions of the carpus, hemorrhage may be controlled by the pressure of the fingers and thumbs of a reliable assistant upon the radial and ulnar arteries, or, if sufficient help is not at hand, by the application of a tourniquet to the brachial artery. It would be useless to attempt to describe the vessels which might need ligation after removal of portions of the hand. Both the deep and superficial palmar arches, when cut, usually require ligation at both severed extremities. To control general oozing from vessels too small to ligate, the application of prepared chalk or hot water will be found of great value.

So, too, it would be out of the question to lay down any rules for the approximation of the flaps: here, as in all irregular amputations, there is ample scope for the exercise of the surgeon's snap ingenuity in making the best use of the tissue retained, and in forming a stump which is free from

tension and which will afterwards give the patient the best use of his limb. A skein of catgut, consisting of half a dozen strands, is placed in the bottom of the wound, emerging at its angles, for drainage. Approximation is effected by the introduction of interrupted sutures at intervals of about half an inch. A narrow strip of protective is placed along the line of the wound, iodoform is freely dusted upon it, and a pad consisting of about twenty-four layers of corrosive-sublimate gauze is applied, covered with a thin layer of corrosive-sublimate cotton, and closed in oiled silk. The hand and forearm are retained to a palmar splint, which has been carefully padded so that it shall give good support without undue pressure at every point of contact.

**Amputation at the Wrist-Joint.**—Though amputation at the wrist-joint is an operation which is seldom performed, it may become necessary, either for disease involving the carpus but not extending into the radio-ulnar articulation, or for injury. The loss of function consequent upon the changes which occur in this latter joint is not sufficient to warrant the performance of an amputation higher up. For, although pronation and supination may be to some extent interfered with, the resulting stump is likely to be more useful than if all connection between the radius and ulna is severed.

*Operation.*—After the application of a tourniquet to the brachial artery, a long anterior oval flap should be cut, extending half-way into the palm. This may be done by transfixion, including all the tissues down to the bone, or by carrying the incision from without inward. The horns of the incision correspond with points just below the styloid process of the radius on the outer side, and half an inch below the styloid process of the ulna on the inner side. A short posterior flap is then cut upon the dorsum, the flexor and extensor tendons are divided, and the joint is laid open with the point of the knife, entering the capsular ligament while the hand is firmly flexed by the operator. The lateral ligaments are then divided, and the operation is completed by severing any tendons which remain undivided. Before removing the tourniquet the larger vessels, including the radial, ulnar, and interosseous, should be secured. Then, removing the tourniquet, any small arteries which bleed must be carefully ligated. A drainage-skein consisting of six strands of catgut being placed in the bottom of the wound, and extending out of the external and internal angles, the flaps are approximated by interrupted catgut sutures placed at intervals of half an inch apart. A thin strip of protective is placed over the line of incision, the stump is freely dusted with iodoform, and the dressing of corrosive-sublimate gauze, consisting of about twenty-four thicknesses, is neatly folded around it. A layer of corrosive-sublimate cotton outside of this, covered with oiled silk, completes the dressing, and the forearm is placed upon a comfortably-padded straight splint.

**Amputation of the Forearm.**—The two common methods of performing this operation are either by antero-posterior flaps, or by the method of Teale, presently to be described. In the oval flap method two flaps, each

corresponding in length with the diameter of the limb, including the whole integument, are dissected up, and the muscles are divided by a circular incision made by a single sweep of the knife. A catling is then passed between the radius and ulna at a point on a line with the circular incision, and all the interosseous tissues are divided. A three-tailed retractor is then employed to hold back the flaps, and the bones are sawn through simultaneously. The radial, ulnar, and interosseous arteries, and occasionally some small muscular branches, require the ligature.

*Teale's Amputation.*—This amputation is the only one which requires for its accurate performance that the lines of incision shall be mapped out upon the skin by an aniline pencil. It consists in the formation of two rectangular flaps, a shorter and a longer one. The shorter flap invariably contains the blood-vessels. The longer flap in length is one-half the circumference of the limb at the point of amputation. The shorter flap is one-third the length of the longer. These flaps are made to include all the tissues down to the bone. The catling is used to divide the interosseous tissues, a retractor is introduced as in the oval flap method, and the bones are divided at the base of the flaps. The longer flap being reflected upon itself and its terminal extremity being brought into apposition with that of the shorter flap, the cicatrix occurs at a point remote from the end of the stump, and the latter becomes smooth and symmetrical. To obtain this approximation, one angle of the long flap is stitched with an interrupted suture to the corresponding angle of the short flap. The opposing angles are treated similarly. An interrupted suture is placed in the middle, and the sides are brought together in such a way as to unite the long flap, near its base, to its reflected terminal extremity. Intermediate sutures are then introduced at intervals of about half an inch, the drainage catgut being carried through the upper angle of the wound. Narrow strips of protective are placed over the wound, the line of which is shaped like the letter H. After dusting iodoform freely over the stump, a dressing of corrosive sublimate cotton is made to envelop it, and oiled silk is carefully folded round the entire dressing. The stump is retained to a carefully-padded splint extending up to the elbow-joint.

**Amputation of the Elbow-Joint.**—Though the nature of the injury and the condition of the adjacent soft parts often may necessitate the performance of an irregular amputation at this articulation, the formal operation consists in the formation of a long anterior and a short posterior flap, as follows. The operator, placing his thumb and index finger over the internal and external condyles of the humerus, enters the blade of a long amputating knife just below and slightly anterior to these points. The knife is then carried downward, closely hugging the bones, a distance equal to the diameter of the forearm, when it is curved outward quite abruptly. From the angles of this incision, a cut is made straight across the back of the forearm just below the olecranon process. The transfixing incision frequently opens the capsular ligament of the elbow-joint, when the disarticulation is readily accomplished by a few light touches of the point of the knife while

the forearm is kept rigidly extended. A saw is then placed in the greater sigmoid cavity of the ulna, and the bone is divided, leaving the olecranon

FIG. 16.

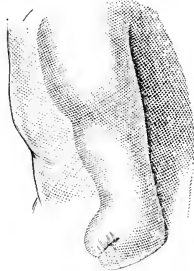

Stump resulting from amputation just below the elbow-joint.

behind. This amputation leaves a very useful stump and one to which an artificial appliance may be adapted, though not nearly so advantageously as if the smallest part of the forearm is retained. Fig. 16 shows an amputation of the forearm performed by the writer at the Episcopal Hospital, in which very small portions of the radius and ulna were retained, but the patient had complete flexion and extension of the stump, and the function of his limb was thereby very much better than it would have been had the amputation been performed at the elbow-joint. I have seen a well-digger, with this most excellent substitute for a hand, lift a heavy bucket of sand from the bottom of a well with great ease, handling the rope almost as readily as

with his sound limb. I have also seen a man row a boat holding the handle of one oar in this flexure of his elbow; and to see a man holding one rein with this stump in driving is a matter of common observation.

**Amputations of the Arm.**—Amputations of the arm from the elbow to the shoulder are performed by the oval flap method with circular division of the muscles, by oval flaps made by transfixion, or by the rectangular flaps of Teale as hitherto described.

*Oval Flap Method with Circular Division of the Muscles.*—Entering the knife at the outer aspect of the arm, an incision, which is made to include the skin and the superficial fascia, is carried down in a curvilinear direction a distance equal to two-thirds the diameter of the limb, whence it ascends the inner aspect of the arm to a position opposite to the starting-point. A similar cut is made at the back, and the anterior and posterior integumentary flaps are rapidly dissected up with light touches of the point of the knife. Held back by an assistant, these flaps are kept well out of the way, while the knife is made by a single circular sweep to divide all the muscles down to the bone. A two-tailed retractor is then placed in position, and the humerus is sawn through at a point a little higher up than the level of the circular division of the muscles. The brachial artery first requires the ligature, and the ligation of the smaller muscular branches, according to the point at which the amputation is performed, completes the operation.

*Operation by Transfixion.*—The knife is entered at the inner (right) or outer (left) aspect of the arm, penetrating directly to the bone; its point, on reaching the latter, is made to hug the humerus closely, the tissues being grasped meanwhile and carried forward by the left hand of the operator, and it is thrust through a point on the opposite side corresponding to that of entrance. By a sawing motion the blade is then carried downward and gradually curved towards the surface to form a flap two-thirds the diameter

of the limb. A posterior flap of like form and size is made in a similar manner by re-entering the knife at the angle of the wound and carrying it behind the humerus. Before removing the tourniquet a ligature should be applied to the brachial artery. As this vessel occasionally divides high up into two trunks, it is a proper precaution to be prepared to find two arteries in the arm, and not to omit ligating one of them, on the supposition that it is a vein.

*Operation of Teale.*—The rules for the formation of the flaps in this operation, as just laid down for amputation of the forearm, are carried out in a similar manner on the arm. In order that the shorter flap shall contain the principal blood-vessel, it is made upon the inner side. After the ligation of all vessels which bleed, and the control of any general oozing which continues, the flaps are ready for approximation. This is accomplished, after the introduction of a skein consisting of about one dozen strands of rather heavy catgut for drainage, by inserting interrupted catgut sutures at intervals of about three-quarters of an inch. The line of the wound is then covered throughout its length with a half-inch strip of protective, iodoform is freely dusted over the stump, and corrosive-sublimate gauze consisting of about three dozen thicknesses is applied. Outside of this a generous layer of corrosive-sublimate cotton is neatly retained by a piece of oiled silk or two sheets of wax-paper, and a roller bandage completes the dressing.

**Amputations at the Shoulder-Joint.**—Amputation at the shoulder-joint in children, as in adults, may be practised by the methods of Larrey, Spence, Dupuytren, or Lisfranc, or, particularly when done for injury, by a modification of either of these. The method of Larrey, when practicable, is usually to be preferred.

*Larrey's Operation.*—Entering the point of the knife just beneath the acromion process of the scapula, an incision reaching to the bone is carried straight downward a distance corresponding to the diameter of the arm. Curving off from this point forward and backward, two other cuts are made, approaching each other on the inner side, but both falling short of the brachial artery. The head of the bone, covered by its capsular ligament, is then brought clearly into view by dissecting up these oval flaps in front and behind. Pressing the arm firmly to the side of the body, the capsular ligament is put upon the stretch, and is readily divided by the point of the knife. By forcible rotation of the arm inward the tendons of the supraspinatus, infra-spinatus, and teres minor are put upon the stretch, and are divided. By rotation outward the tendons of the biceps and of the subscapularis are in like manner made tense, and divided, when the head of the bone slips easily out of its socket. A long knife is then placed in position, blade downward, behind the humerus, preparatory to dividing the remaining tissues. An assistant now grasps with his thumbs and fingers the uncut portion of the flap containing the blood-vessels. The knife is carried downward, closely hugging the bone, until it reaches the curved incisions



which have already been made, when its course is directed in their line abruptly to the inner side, the assistant's fingers having followed it to this critical point. The limb thus severed leaves the flap containing the blood-vessels in the hand of the assistant. The brachial artery is promptly seized with the forceps and tied; the brachial veins require separate ligatures; other vessels, including the circumflex, also require ligation.

*Spence's Operation.*—Spence's operation differs from Larrey's mainly in that the perpendicular incision is started anterior to, instead of on a line with, the acromion process. The object of this modification is to secure a somewhat more shapely stump, and also to sever the smaller branches of the circumflex artery instead of the larger ones. After forming the anterior and posterior flaps, dissecting them up, and disarticulating the head of the bone, the operation is completed in a similar manner to that of Larrey.

*Dupuytren's Operation.*—The point of the knife is introduced at the back of the shoulder behind the acromion process, and is carried straight forward through the mass of tissue overlying the head of the humerus, which has been picked up by the left hand of the operator, to a point just outside the coracoid process of the scapula. In performing this transfixion, the capsular ligament upon its outer side is apt to be opened. An oval flap is then formed of muscle and integument, which extends down as far as the insertion of the deltoid, the head of the bone is disarticulated as in the method of Larrey, and the posterior flap is quickly formed, while the vessels are controlled by an assistant. The cicatrix which results is transverse instead of vertical.

*Lisfranc's Operation.*—The arm being elevated, in order to relax the tissues of the shoulder, the point of a long knife is entered midway between the coracoid and acromion processes, and is carried in a direction backward and downward, so that it will emerge at the posterior fold of the axilla. A musculo-cutaneous flap is then cut corresponding in length to one-third the diameter of the arm. The head of the humerus is readily dissected out, and, being raised from the glenoid cavity, preparation is made to cut the inner flap. An assistant places both thumbs behind the bone, upon the vessels, while his fingers are used for counter-pressure in the axilla. The surgeon then re-enters his knife, and as he carries it down along the bone the assistant's thumbs closely follow its track while a short internal flap is formed.

*Amputation of the Entire Upper Extremity.*—This operation, which includes the removal of the scapula and clavicle, has seldom been performed. When the injury or disease will permit, the operation consists in dissecting out the scapula and clavicle after amputating at the shoulder-joint. The scapula is removed through an incision carried along the length of its spine, the supra- and infra-spinous mass of muscles being dissected up, and a few bold sweeps of the knife readily separate the bone from its loosely-adherent attachments beneath. The clavicle is removed through an incision which reaches from its sternal articulation outward. After dividing

the ligaments at this joint, it is in like manner dissected away from the tissues surrounding it.

Portions of this operation are not infrequently required after injury, in order to secure proper approximation of the flaps when the lesion has extended too far to render a shoulder-joint amputation possible. Fig. 17 represents the result of one of these partial upper-extremity amputations. Although the subject was an adult, not a minor, it serves equally well for the purposes of demonstration. The patient was operated upon by the writer at the Episcopal Hospital. His shoulder had been caught in cog-wheels, and the destruction of the integument had extended so far inward that, in order to make flaps which would sufficiently cover the gap, it was found necessary to remove the acromion process along with part of the spine of the scapula and the outer half of the clavicle. The patient made a good recovery, with a comfortable stump, the peculiar form of which is well shown in the drawing.

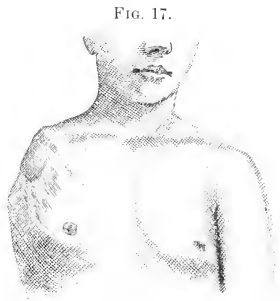

Fig. 17.  
Stump following amputation of the arm along with parts of the scapula and clavicle.

AMPUTATIONS OF THE LOWER EXTREMITY.

**Amputations of the Toes.**—What has been said of amputations of the fingers is generally applicable to amputations of the toes. In amputations of the latter, as in amputations of the foot, it is very desirable to avoid, when possible, the placing of a cicatrix anywhere upon the plantar surface. Long anterior flaps, therefore, are to be made whenever practicable. As in the hand, irregular operations, including removal of the destroyed tissues, independently of articulations, are proper. Fig. 18 represents the result following the removal by the writer of the second and third toes, along with their metatarsal bones. Fig. 19 represents a foot after the removal of the second toe and its metatarsal bone.

Fig. 18.



Foot after removal of the second and third metatarsal bones and their toes.

Fig. 19.



Foot after removal of the second metatarsal bone and its toe.

Two important facts must be borne in mind in determining the propriety and character of these irregular operations about the foot. One is the important part which the inner side of the foot plays in locomotion. A patient in whom the ball of the foot and the

great toe have been preserved will often walk with almost no limp, and with a gait which is very much in contrast with that of an individual who, having had all his other toes preserved, has lost the great toe. This fact justifies the surgeon in taking great risks of sloughing, and even of a second operation, in his attempts at preserving this portion of the foot. The other important thing to be remembered is that the foot, unlike the hand, will not usually be given the kind of subsequent care by the patient which will permit a tender or tense cicatrix to become strong and to stand pressure.

**Tarso-Metatarsal Amputations.**—*Lisfranc's Amputation.*—With the index finger and thumb, two points are sought on the inner and outer aspects of the foot, which serve as a guide for the inner and outer angles of the

FIG. 20.

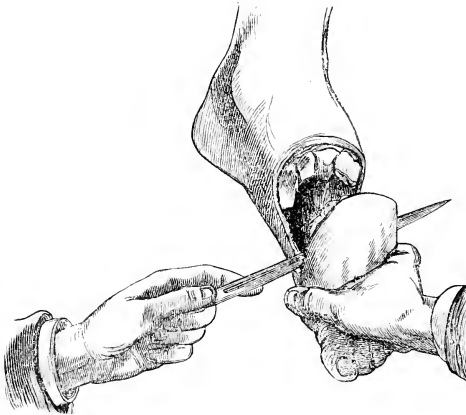

Formation of plantar flap in Lisfranc's amputation. (After Agnew.)

anterior flap. These are the apex of the internal cuneiform bone and the tuberosity of the metatarsal bone. Between these a short flap with its convexity downward is made, the integument is dissected back, and, with strong pressure made upon the foot, the tarso-metatarsal joints are opened. The articulation of the second metatarsal bone, being higher up and out of line with the others, requires a little careful touching with the point of the knife, in order to free it. The joint being thus opened, disarticulation is completed by a few light touches of the knife. The plantar flap is then formed by carrying the knife close to the bone downward to a point on the inner side which includes the tissues forming the ball of the foot, and on the outer side to a point a little short of this. The object of this obliquity in the plantar flap is to cover properly the end of the stump, which is thicker on its inner than on its outer side. A modification of this operation, called, after its designer, Hey's, leaves the base of the second meta-

tarsal bone behind, by cutting through the shaft of the bone with a saw, instead of disarticulating it.

*Chopart's Amputation.*—In this the astragalus and calcaneum are the only bones of the tarsus preserved. The anterior flap is formed by entering the knife over the tuberosity of the scaphoid bone on the inner side, carrying it downward across the foot, and in an easy curve backward to the tuberosity of the fifth metatarsal bone. After dissecting up this flap, including in it skin and superficial fascia, a few light touches with the point of the knife, while the foot is pressed forcibly downward with the left hand of the operator, will readily open the joints between the head of the astragalus and the scaphoid and between the calcaneum and the cuboid bone. Placing the blade of the knife between the freshly-disarticulated bones of the tarsus and the plantar tissues, a posterior flap is cut by a gentle sawing movement of the knife. This flap should be longer on the inside than on the outside, and should extend down almost as far as that for Lisfranc's amputation,—viz., to the tissues forming the ball of the foot. Before removing the tourniquet, the dorsalis pedis and several plantar branches, varying somewhat according to the exact points of incision, of the posterior tibial artery should be ligated. A drainage catgut skein should be placed in the bottom of the wound, emerging from the inner and outer angles, and, if suppuration is expected, a portion of it may well be carried out through a central button-hole pierced in the plantar flap. Neat approximation is effected by points of catgut suture placed at intervals of about half an inch. A narrow strip of protective is made to cover the length of the wound, which is afterwards dressed in the usual way, with a free sprinkling of iodoform, about two dozen thicknesses of corrosive-sublimate gauze, a gauze bandage, a layer of antiseptic cotton, and wax-paper. The retaining bandage should be carried up as far as the knee, in order to control and give support to the muscles of the calf.

*Amputations of the Ankle-Joint.*—*Syme's Amputation.*—In this operation the entire foot, along with the external and internal malleoli, is removed. An excellent stump and one which stands pressure admirably well results, as the strong dense tissues of the heel are utilized in making a long posterior flap. Entering the point of the knife over the external malleolus, a curved incision is carried across the top of the foot to a corresponding point on the opposite side,—namely, not to the tip of the internal malleolus, but to a point one-third nearer the heel. The angles of this cut are connected by an incision carried straight across the sole of the foot, when the os calcis is carefully dissected out from the tissues of the heel, to which it will be found very firmly attached. The ankle-joint is then opened from before backward, and, after disarticulation, the lower extremities of the tibia and fibula are sawn off at a point which will include a thin slice of the articular surface of the former. In doing this, care must be taken not to wound the posterior tibial artery. The posterior flap should be carefully applied to the bones of the leg during the approximation, in order to avoid leaving a pocket in

the stump. Approximation is effected by the introduction of points of catgut suture at intervals of half an inch. The wound is dressed as in Chopart's operation.

*Pirogoff's Amputation.*—In this the posterior half of the calcaneum is retained in the heel-flap, and is turned up and applied to the bones of the leg. While not so applicable to cases of disease of the bone as Syme's operation, because there is always the risk of the caries attacking the retained portion of the heel-bone, it certainly possesses the advantage over the latter of giving a decidedly longer stump. This, though a matter of no consequence to the artificial-limb manufacturer, as the length of the Syme's stump gives him sufficient length for the application of an artificial foot, is well worth considering in the interest of a poor patient. With a Pirogoff stump a man can get on, as a rule, perfectly well without an artificial foot; indeed, I recall one who, with an ordinary shoe and a little oakum stuffed in the heel, walked with a limp so slight that the true nature of his deficiency would hardly suggest itself. But this amputation, to give its best result, must be carefully and dexterously performed.

The anterior flap is formed by a slightly convex incision extending from the lower point of the internal to the tip of the external malleolus. The angles of this cut are connected by an incision carried straight across the sole of the foot. The ankle-joint is opened and the astragalus disarticulated. Next comes the division with the saw of the calcaneum and of the articular extremities of the tibia and fibula, upon the accuracy of which the usefulness of the stump will largely depend. Applying a butcher's saw just behind the articulation of the astragalus with the os calcis, the latter is sawn through in a direction downward and slightly forward; the saw is then applied to the anterior aspect of the tibia, and is carried through a point just high enough to include all of the articular cartilage along with both malleoli in a direction backward and slightly upward. This oblique section of the os calcis and of the bones of the leg causes the turn the former makes in being applied to the latter to be slightly less than a quarter of a circle. In this way the dense tissues of the heel will be to a great extent retained, to receive their accustomed pressure, instead of the much less able structures upon its posterior aspect. Some surgeons prefer mortising the fragment of bone between the malleoli, and so much does the size of the os calcis vary in relation to the width of the socket at the ankle that occasionally it will be found to fit very nicely. When it is intended to do this, more of the os calcis must be sawn off, in order to avoid bony tension after approximation. Approximation is accomplished by the introduction of interrupted catgut sutures at intervals of half an inch, after placing a catgut drain in the bottom of the wound. The wound is dressed as after Syme's amputation, except that a card-board splint is nicely adapted to the posterior aspect of the limb.

*Amputation of the Leg.*—In cases where the involvement of the tissue from disease or injury extends too high for the performance of Syme's am-

putation, the point of election is now usually admitted to be not higher than the junction of the middle with the lower third; for, although at this point not so much tissue exists for the formation of an ample cushion to cover the bone, with properly-formed flaps the resulting stump readily stands the retraction caused by the socket of the artificial limb, and the increased leverage gained is of manifest utility in locomotion. The operation which at this point gives the best results consists of the long anterior oval flap of integument, reflected backward upon a short musculo-cutaneous flap; the latter can well be made by transfixion. Where the damage to the integument precludes the formation of a long anterior flap, antero-posterior oval flaps of equal length composed of integument, with a circular division of the muscles, is an operation which has been regarded favorably in this country, albeit the cicatrix occurs over the ends of the bones. It must be admitted that Teale's amputation, as applied to the leg, is rather prodigal of tissue, and particularly so to the leg of a muscular subject.

By the long oval anterior flap method the knife is entered a short distance to the outer side of the spine of the tibia, and carried in a direction downward a distance corresponding to the diameter of the limb at the starting-point, when it sweeps in an easy curve across the front of the leg, and upward an equal distance on the inner side. The plane of this anterior flap should be slightly inverted,—*i.e.*, the external angle of the wound should be on a plane anterior to that of the internal angle,—in order that the spine of the tibia shall occupy a position in the middle of the flap. The detachment of this flap from the deep fascia is very readily accomplished by a few light touches of the knife. Entering the latter at either angle which is more convenient, its blade is passed behind the fibula, brought out on the other side, and curved rather abruptly backward, in order to make the short posterior flap. A catling is then employed to divide the interosseous tissues, and, everything being held well out of the way by means of a three-tailed retractor, the bones are sawn through. The saw should first be made to engage itself in the tibia, when its line of motion is altered so that it will cut through the fibula, after which the section of the tibia is to be completed. Before removing the tourniquet, ligatures should be applied to the anterior tibial, interosseous, and posterior tibial arteries.

At this point I cannot but recommend a procedure the advantage of which has been criticised. It is the sawing off of the prominent right angle of the spine of the tibia. It has been urged that by so doing two angles of bone, instead of one, are made to press upon the anterior flap. True, but very obtuse angles they are, and in old subjects particularly, where every care has been taken to give the stump proper support, I have occasionally been much annoyed to see this angle of bone finding its way through the skin. After approximation by interrupted catgut sutures at intervals of three-quarters of an inch apart, the line of the wound will be found to be well back of the end of the stump.

Where the injury or disease has involved the limb so high up that there

is not sufficient sound integument to form oval flaps, a modification of the old circular amputation will be found very economical. Entering the knife at the inner or outer aspect of the leg at a point corresponding to one-half its diameter, a very slightly curved incision is carried across the front to the opposite side; and a similar cut is made at the back, thus forming two very flat-ended flaps. These are dissected up a considerable distance above the position of their angles, when a circular division of the muscles is made by one sweep of the knife. A catling is then thrust between the bones and a three-tailed retractor is introduced. The division of the bones with the saw should be made from one-half to one inch higher up than the plane at which the muscles were divided. This operation is particularly applicable just below the knee, when there is no room to perform an amputation by any other method without losing the knee-joint.

**Amputation at the Knee-Joint.**—In the operation which I prefer a long anterior flap is made and the patella is retained. This method is, of course, much more frequently applicable after injury than for disease. Properly performed, the anterior flap falls as a hood over the condyles of the femur, bringing the line of cicatrix well back of the point of pressure, the patella usually becomes ankylosed to the femur, and a strong, tough, somewhat knob-shaped stump results, admirably adapted for the socket of an artificial limb.

The knife being entered just below and a little behind the external condyle of the femur, it is carried straight downward to a distance below the tuberosity of the tibia corresponding to the diameter of the limb at this position, when an anterior oval flap is formed by carrying it across the limb and back to a point on the opposite side corresponding to the starting-point. This flap, including the skin and superficial fascia, is dissected up as far as the patellar tendon, which, while the leg is forcibly flexed upon the thigh, is divided close to its sesamoid bone, when the condyles of the femur will be exposed to view. After completing the division of the anterior portion of the capsular ligament of the knee-joint, the lateral ligaments are severed. In effecting this disarticulation care must be taken not to divide the ligamentum mucosum, as this membrane assists very materially in retaining the thigh-tissues to the knee, for even in the cadaver, where the precaution has been taken of making the base of the anterior flap extend over two-thirds of the circumference of the knee, when this membrane is cut the thigh-tissues retract so much that the entire end of the femur is denuded and thrust out. In cutting the posterior portion of the capsular ligament it should be borne in mind that the popliteal artery is in close proximity. Whilst the leg is completely flexed upon the thigh, the blade is snugly insinuated behind the tibia, and is made to form a musculo-cutaneous posterior oval flap one-third the length of the anterior. Lateral oval flaps and triple flaps—*i.e.*, one anterior, two posterior—are occasionally used, but they would not seem to possess ordinarily any advantages over the operation above described.

**Amputation of the Thigh.**—The operation of Mr. Carden,<sup>1</sup> through the condyles, gives the longest thigh-stump of any amputation. It is described by him as follows: "The operator, standing on the right side of the limb, seizes it between his left forefinger and thumb at the spots selected for the base of the flap, and enters the point of the knife close to his finger, bringing it round through skin and fat below the patella to the spot pressed by his thumb; then, turning the edge downward at a right angle with the line of the limb, he passes it through to the spot where it first entered, cutting outward through everything behind the bone. The flap is then reflected, and the remainder of the soft parts divided straight down to the bone; the muscles are then slightly cleared upward, and the saw is applied." The condyles are then cut through at a right angle with the line of the limb. In this operation it is possible to make an exploration of the knee-joint after the formation of the upper flap. In cases of disease of the latter, before determining whether to do a resection or an amputation, Carden advises always removing the patella.

Mr. Lister prefers a modification of this method, as follows:<sup>2</sup> "The surgeon first cuts transversely across the front of the limb from side to side, at the level of the anterior tuberosity of the tibia, and joins the horns of this incision posteriorly by carrying the knife at an angle of forty-five degrees to the axis of the leg through the skin and fat. The limb being elevated, he dissects up the posterior skin-flap, and then proceeds to raise the ring of integument as in a secular operation, taking due care to avoid scoring the hamstrings as soon as they are exposed, and bending the knee he finds no difficulty in exposing the upper border of the patella. He then sinks his knife through the insertion of the quadriceps extensor, and, having cleaned the bone immediately above the articular cartilage, and holding the limb horizontal, he applies the saw vertically and at the same time transversely to the axis of the limb (not of the bone), so as to insure a horizontal surface for the patient to rest on. The popliteal artery and vein are then secured, and any articular or other small branches that may require it."

At any point in the thigh above the condyles, antero-posterior flaps, consisting either of integument or of integument and muscle, should be modified to suit the character of the case. Such modifications frequently become necessary after injury. Thus, the wheel of a car passing obliquely over the limb will frequently tear away a great extent of tissue on one side, while the tissues on the opposite side remain undamaged. A long lateral flap in such cases will enable the surgeon to preserve the greatest amount of tissue. When the formal operation is practised, an oval flap made by transfixion, in length two-thirds the diameter of the limb where the bone is to be cut, and a posterior flap of similar length, consisting of integument alone,

<sup>1</sup> Henry D. Carden, Esq., *British Medical Journal*, 1864, vol. i.

<sup>2</sup> *Holmes's Surgery*, vol. iii. p. 718.



or of integument and a small amount of muscular tissue, will give the best result.

Entering a long amputating knife directly over the *linea aspera*, its point is carried directly to the bone, while the left hand of the operator grasps the tissues of the thigh in front, so that they will bulge forward. On reaching the bone, the point of the blade is made to ride over the femur and emerge at a point on the opposite side, to form the base of a flap which shall include the semi-circumference of the limb. The knife is then made to describe an easy curve to the front of the thigh, where it emerges at a distance from the point of entrance equal to two-thirds the diameter of the limb. Elevating the limb, the knife is placed upon the posterior aspect of the thigh at a point which will reach the extremities of the anterior cut, when it cuts at an angle of forty-five degrees to the axis of the limb. The muscles attached to the bone are rapidly dissected free, and after the application of a two-tailed retractor the saw is applied a little higher up than the angles of the wound.

After placing a thick skein of catgut drain in the latter, the flaps are coaptated by two or three interrupted sutures, placed so deeply that they shall include at least one-half the length of the flaps. In order that these deep sutures shall not interfere with the circulation in the stump, they should be tied with very little tension. The skin-edges are neatly approximated by interrupted catgut sutures placed at intervals of three-quarters of an inch. The line of the wound is then covered with a narrow strip of protective and freely dusted with iodoform; a thick layer of corrosive-sublimate gauze is retained with a gauze bandage; after which a generous layer of corrosive-sublimate cotton covered with wax-paper and retained by a roller bandage completes the dressing. If the amputation has been performed above the middle of the thigh, the retaining bandage should terminate in a spica of the groin. A nicely-fitting card-board splint occupying the posterior aspect of the thigh and terminating in a cup-shaped form, which will adapt it to the end of the stump, will add materially to the comfort of the patient in this as in other amputations of the lower extremity. The amputation performed in the manner last described makes a most admirable stump.

**Amputation at the Hip-Joint.**—In amputating at this articulation the two great causes of the fatality of the operation have to be combated,—hemorrhage and shock. Without enumerating the various methods which have been proposed and practised to control the former, I shall simply describe that by the elastic band, as at once the most efficient and powerful without being harmful. It should be applied in the form of a spica of the groin, in such a way that it will not slip off the flaps after the head of the femur is disarticulated. As the rules laid down by Mr. Lister for the application of Esmarch's bandage could not be improved upon, I shall quote them as he writes:<sup>1</sup>

<sup>1</sup> Holmes's Surgery, vol. iii. p. 722.

“An elastic band having been provided, sufficiently strong to require the full force of the surgeon to stretch it to twice its length, and long enough to encircle the upper part of the limb when in the relaxed condition, and with tapes securely connected with its ends, is placed with one end of the elastic part under the sacrum, while the tape of that end is brought round the pelvis between the crest of the ilium and the great trochanter of the side opposite to that to be operated on, and held perfectly firmly in the vertical position by an assistant. The surgeon then, standing on the side for operation, puts the band fully on the stretch in a direction transverse to the body, and brings it up into the vertical position immediately below the iliac crest. Holding it in his left hand (if the right limb is concerned), he next passes his right hand round behind the limb, which has been previously placed in the vertical position to expel its blood, and, changing hands, encircles the thigh as near to the perineum as possible, the scrotum being held well to the other side by an assistant. The surgeon's end of the elastic band being now over the groin, he takes the other tape from his assistant and ties the two tapes together in a reef-bow over the sound side.

“Another point requires attention. Two pieces of bandage, each about two feet in length, are placed longitudinally upon the skin before the elastic band is applied, one of them over the groin, the other well behind the great trochanter, the middle of each piece of bandage being in the situation where the elastic band is to go. And when the elastic band has been applied, the lower end of each of these pieces of bandage is drawn up, so as to convert them into two loops, by means of which, in the hands of a steady assistant, the elastic tourniquet is kept drawn well up both at Poupart's ligament and behind the trochanter. If this arrangement is well carried out, the whole operation, including disarticulation, may be done uninterruptedly.”

Shock in this way having been prevented in so far as it depends upon the loss of blood, its remaining element, which is the division of such an extensive mass of tissue so near the trunk, can be further diminished by severing the tissues at a point more remote from the hip. Mr. Farneaux Jordan, of Birmingham, emphasizes the importance of this thus: “First enucleate the bone, then cut through the limb at any desired spot,—the middle of the thigh or below, or even below the knee.” This rule, of course, relates mostly to amputations done for disease of the femur, and would seldom be applicable to an operation required by injury; but the importance of the principle should never be lost sight of.

If the flaps are so formed that the inner side of the wound, that nearer the anus, can be closely sealed to keep it aseptic, the outer side may be used for drainage to great advantage. Mr. Lister carries an incision from the back part of the great trochanter straight down the thigh a distance corresponding to the greatest diameter of the latter. He then curves it first in front, then behind through the skin and the superficial fascia, with a slight slant to the inner side. Dissecting this flap up, as in a modified circular

operation, the muscles are divided where they are exposed, and the head of the bone is dissected out.

The other methods which have been adopted I shall but briefly describe. They are by oval integumentary flaps, cut from without inward, and musculo-cutaneous flaps, made by transfixion. In the former method, an anterior flap, consisting of the skin and superficial fascia, and corresponding in length to the diameter of the thigh, should be cut from a point midway between the trochanter major and the anterior superior spinous process of the ilium to a point a finger's breadth below the ramus of the pubis. At the base of this flap, after it is dissected up, the femoral artery is ligated, and also the femoral vein. With the limb elevated, a posterior integumentary flap is formed, which is made one-quarter shorter than the anterior. With a long knife a circular division of the muscles is made in front of the joint. The capsular ligament is divided anteriorly, being put upon the stretch by forced extension of the thigh, when the ligamentum teres becomes exposed to view and is readily severed by the point of the knife.

By transfixion amputation at the hip-joint can be done with great rapidity. The point of a long amputating knife is entered midway between the anterior superior spinous process of the ilium and the great trochanter of the femur, and is carried in front of the joint in such a direction that it shall emerge upon the inner aspect of the thigh a short distance below the perineum. An anterior flap equal in length to the diameter of the thigh is then formed, and the head of the femur is disarticulated. This is usually quickly accomplished, as the first entrance of the knife is apt to shave through the anterior portion of the capsular ligament. After the head of the bone is freed from its attachments, the knife is placed behind it and made to form a posterior flap about one-half the length of the anterior.

# INDEX TO VOLUME III.

- A.**
- Abdomen, distended, in tabes mesenterica, 210.**  
in acute entero-colitis, 138.  
in peritonitis, 270.  
normal features of, 213.
- Abdominal affections causing enlargement of liver, 428.**  
constrictions, obstructive, 267.  
distention from constipation, 196, 201.  
in hernia, 240.  
dropsy, 511.  
enlargement, causes of, 213.  
from tubercular peritonitis, 214.  
glands in constipation, 215.  
swelling in tabes mesenterica, 212.  
tumors, 213, 732.  
exploratory incision, 734.  
wall, hiatus of, 658.  
nipples on, 752.
- Abduction in hip-joint disease, 1166.**
- Abnormal mobility of the knee, 1124.**
- Abnormalities of the extremities, 929.**  
club-hand, 937.  
congenital, 929.  
contraction of digits in, 943.  
deficiency, 933.  
digital, 938, 941, 943.  
hypertrophy, 930.  
supernumerary digits, 938.  
limbs, 938.  
union of digits in, 938.  
of female genitals, 741.  
of mammary glands, 750.  
of small intestine, 315.
- Abscess, anal, 346.**  
marginal, 346.  
articular, 1152.  
ascaris lumbricoides in, 226.  
caseous deposits in, 1154.  
evacuation of, 1155.  
in bone, 993, 1145.  
causation of, 994.  
symptoms of, 994.  
subacute, 996.  
in hip-joint disease, 1166.  
of hip, 1187.  
of joints, 1153, 1155.  
classification of, 1153.
- Abscess in bone, drainage of, 1155.**  
evacuation of, 1155.  
of liver, 466.  
of pancreas, age of patients, 380, 384.  
antiseptic treatment of, 386.  
cases of, 381, 382.  
causes of, 382, 383.  
description of, 381, 382.  
diagnosis of, 381, 383.  
drainage of, 385.  
evacuation of, 381.  
external fistula for, 385.  
incision of, 385.  
pathology of, 381.  
prognosis of, 384.  
rarity of, 380.  
suturing of incision in, 385.  
symptoms of, 383.  
treatment of, 384, 400.  
tuberculous, 400.  
opening of, 1155.  
palmar and plantar, 845.  
para-pancreatic, 382.  
perilymphatic, 382.  
perinephritic, discriminated from perityphlitis, 301.  
peritoneal, 274.  
perityphlitis, 282, 297.  
statistics of operations for, 311-313.  
plantar, 845.  
psoas, discriminated from perityphlitis, 301.  
rectal, 345.  
residual, of joints, 1153.  
right iliac, 282.
- Abscess-stage in spondylitis, 1025.**
- Abscesses, ascaris lumbricoides in, 226.**  
septic, in jaundice, 412.
- Absence of bladder, 671.**  
of breast, 753.  
of hymen, 749.  
of rectum, 326, 338.  
of vagina, 749.  
of vulva, 749.
- Absolute fixation in hip-disease, 1175.**
- Abstraction of albumen a cause of anemia, 774.**
- Accessory mammae, 754.**  
organs, 367.
- Accidents from anæsthetics, 927.**
- Accumulation of food in the dilated stomach, 50, 51.**
- Accumulations, fecal, 202, 207.**
- Acetabular disease, 1159.**
- Acetate of lead poisoning, 861.**
- Acetonæmia, 765.**
- Acid burns, 855.**  
carbolic, in dyspepsia, 20.  
poisoning, 860.  
sulphurous, in dyspepsia, 20.
- Acid diarrhœa, bacteria of, 185.**
- Acidity in dilatation of stomach, 44.**  
of stomach in dyspepsia, 6.  
not a bar to the entrance of bacteria into the intestines, 72.
- Acids for acute diarrhœal disease, 123.**  
in the blood in leucæmia, 787.
- Aconite-poisoning, 861.**
- Acquired flat-foot, 961.**  
torticollis, 980.
- Acute and chronic constipation, 191.**  
catarrhal inflammation of intestine, 81.  
with non-epithelial lesions, autopsies after, 81.  
croupous inflammation of intestine, 87.  
autopsy after, 87.  
bowel-contents after, 87.  
colon in, 88.  
frequency of, 87.  
gross appearances after, 87.  
microscopical appearances after, 88.  
pseudo-membrane in, 87, 88.  
tubular glands in, 88.
- desquamative catarrh, intestinal, 79, 80.**  
microscopical appearances in, 81.
- diarrhœal disease, brain-lesions in, 89.**  
broncho - pneumonia in, 89.  
heart in, 90.  
intussusception in, 90.  
kidneys in, 90.  
liver in, 90.

- Acute diarrhoeal disease, lung-lesions in, 89.  
mesenteric glands in, 90.  
mouth-lesions in, 89.  
peritoneum in, 90.  
spleen in, 90.  
stomach in, 90.  
tuberculosis in, 89.  
dyspepsia, treatment of, 12.  
dyspeptic diarrhoea, 109.  
entero-colitis, 134. *See* Enterocolitis, Acute.  
epiphysitis in infants, 1237.  
hæmoglobinuria of the new-born, 827.  
infectious diseases liable to joint-complications, 1264  
mycotic diarrhoea, 108. *See* Diarrhoea, Acute Mycotic.  
suppurative synovitis, 1132.  
yellow atrophy of the liver, 507. *See* Liver, Yellow Atrophy of.
- Adams, Wm., method of examination in Pott's disease, 1028.  
on spinal curvature, 1002.
- Addison on pernicious anaemia, 809.
- Addison's disease, 820.  
anatomical features of, 824.  
causes of, 821.  
complications of, 826.  
course of, 826.  
definition of, 820.  
diagnosis of, 826.  
etiology of, 821.  
history of, 821.  
pathological anatomy of, 824.  
pathology of, 825.  
prognosis of, 826.  
sequelæ of, 826.  
symptoms of, 821.  
synonymes of, 820.  
treatment of, 827.
- Adénie, 801.
- Adenitis in tabes mesenterica, 210, 215.
- Adenoid disease, 801.
- Adenoma of the uterus, 717.
- Adherent præpuce, 638.
- Adhesions in joint-disease, 1151.
- Adhesive plaster, 842.  
union, 871.
- Adolescence, albuminuria of, 530.
- Advantages of arthrectomy, 1218.
- Alymania as a cause of gastric dilatation, 43.
- Affections simulating enlargement of the liver, 426.
- African chlorosis, 773.
- Age in chlorosis, 778.  
in leukaemia, 784.  
in lymphatic anaemia, 801.  
in pernicious anaemia, 810.  
in splenic anaemia, 799.  
in spinal curvature, 1003.  
relation of, to the weight of the liver, 405.
- Agnew, case of face smashed, 1057.
- Air, changes of, as causing diarrhoeal disease, 66.  
curative influence of, in cases of diarrhoea, 113.
- Akinetic curve, 1007.
- Albumen-abstracta a cause of anaemia, 774.
- Albuminoids, effect of the pancreatic juice on, 370.
- Albuminuria, or Bright's disease, causes of, 525.  
chyluria in, 529.  
treatment of, 529.  
etiology of, 525.  
functional, 530.  
treatment of, 530.  
hæmaturia with, 526.  
morbid growths in, 530.  
suppuration in, 525.  
treatment of, 528, 529, 530.
- Alcoholic cirrhosis, 494.
- Alcoholics as a cause of gastric catarrh, 35.
- Alcohol-poisoning, 862.
- Alimentary canal, development of, 321.
- Alimentation in gastric dilatation, 51. *See* also Diet under the names of various diseases in this index.
- Alkali burns, 855.
- Alkaline-poisoning, 860.  
treatment of acute diarrhoeas, 124.
- Allis, Dr. O. H., on anaesthesia and anaesthetics, 913.  
on fracture at elbow, 1073.  
of neck of femur, 1084.
- Altered blood-conditions, 762.
- Amastia, 753.
- Amaurosis after gastric hemorrhage, 57.
- America, hydatid rare in, 446.
- American hip-splint, 1184.
- Ammonemia, 765.
- Amputation in compound fracture of femur, 1092.
- Amputations, 1311.  
ankle, 1327.  
appearances after, 1312.  
approximation of flaps in, 1316.  
arm, 1322.  
arrest of hemorrhage in, 1315.  
at wrist, 1320.  
at wrist-joint, 1320.  
control of hemorrhage in, 1314.  
digital, 1317, 1325.  
division of bones in, 1315.  
fingers, 1317.  
formation of flaps in, 1315.  
general remarks on, 1311.  
hip, 1332.  
knee, 1330.  
leg, 1328.  
lower extremity, 1325.  
of ankle, 1327.  
of arm, 1322.  
of elbow, 1321.  
of forearm, 1320.  
of leg, 1328.  
of lower extremity, 1325.  
of thigh, 1331.
- Amputations of toes, 1325.  
of upper extremity, 1317, 1324.  
operation of, 1313.  
special, 1317.  
tarsometatarsal, 1326.  
technique of operation, 1313.  
upper extremity, 1317, 1324.
- Amussat's operation for imperforate anus, 328, 330.
- Anyloid degeneration, 94.  
in hip-disease, 1192.  
of liver, 439. *See* Liver, Amyloid.
- Anæmatisis, 808.
- Anæmia, 770.  
anatomical characters of, 776.  
artificial, 1261.  
as a cause of gastric catarrh, 35.  
chlorosis with, 771.  
classification of, 770.  
cytogenic, 770.  
diagnosis of, 776.  
from abstraction of albumen, 774.  
infantum pseudo-leukæmia, 794.  
in leukæmia, 785.  
leukæmic, 771.  
lymphatic, 801.  
microcytes in, 764.  
non-cytogenic, 772.  
of malnutrition, 774.  
parasitic, 778.  
pathology of, 776.  
pernicious, 772.  
post-hemorrhagic, 774.  
simple constitutional, 797.  
definition of, 797.  
pathology of, 797.  
symptoms of, 798.  
treatment of, 798.  
splenic, 798.  
symptoms of, 775, 798.  
toxic, 772.  
treatment of, 776.
- Anæsthesia in children, 841, 913.  
in diagnosis of hip-disease, 922.  
in pelvic examination of children, 733.
- Anæsthetics, 913.  
accidents from, 927.  
chloroform, 914.  
ether, 913.  
suggestions for the administration of, 925.
- Anæsthetic zone, 926.
- Anal cul-de-sac, 331.  
diaphragm, 323.  
malformations, 321.  
classification of, 322.  
development of, 321.  
pathology of, 321.
- Anasæra, 512, 553.
- Anastomosis of intestine, artificial, in congenital occlusion, 320.  
in occlusion from disease, 257.
- Anatomical features of the infantile stomach, 46.

- Anatomical neck of humerus, fracture of, 1063.  
peculiarities in children's joints, 1253.  
tubercle, 898.
- Anatomy of appendix vermiformis, 285.  
of caeculi, 600.  
of female genitals, 711.  
of inguinal hernias, 236.  
of intestine, 76.  
of synovial membrane, 1127.  
pathological. *See* Pathology under the names of the various diseases in this index.
- Anchylostoma duodenalis, mischief done by, 219.
- Anchylostomum duodenale in anaemia, 773.
- Aneurism after fracture of humerus, 1066.  
of aorta, how distinguished from pancreatic cyst, 391.
- Angioma of rectum, 353.
- Angel's wing, 1010.
- Anguilla intestinalis in anaemia, 773.
- Angular curvature of spine, 1019.
- Anhydremia, 770.
- Animal broths, 115.
- Ankle-joint amputations, 1327.  
disease, 1248.  
beginning of, 1249.  
diagnosis of, 1249.  
differential diagnosis of, 1250.  
excision in, 1250.  
pain in, 1249.  
symptoms of, 1249.  
treatment of, 1250.  
tuberculosis, 1261.  
luxations, 1126.  
sprain of, 856.
- Ankylosis, 1258, 1266.  
causes, 1268.  
definition, 1266.  
diagnosis and signs, 1268.  
in wry-neck, 984.  
treatment, 1269.  
of elbow-joint, osteotomy in, 1288.  
of hip-joint, osteotomy in, 1285.  
of knee-joint, 1286.  
of temporo-maxillary joint, 1289.
- Annandale on coronoid fracture, 1075.  
on olecranon fracture, 1075.
- Annandale's operation for wry-neck, 991.
- Anodynes in congestion of the liver, 434.
- Anomalies of communication of the genitals, 749.  
of the kidneys, 516.
- Anterior tibial curvatures, osteotomy for, 1294.
- Anti-q on chlorosis, 783.
- Antipyrin for cyclical vomiting, 24.
- Antiseptic gauze, 841.  
treatment of acute dyspeptic diarrhoea, 120, 122, 123.
- Antiseptics, 882.  
for acute dyspeptic diarrhoea, 122, 123.  
in entero-colitis, 146.
- Antisepsis *versus* asepsis, 123.
- Antisyphilitic medication in dyspepsia, 10.
- Anus, abscess of, 346.  
absence of, 333.  
artificial, 325-331.  
after colotomy, 359.  
consequences of forming, 357.  
operation for, 323, 324, 325, 326, 357. *See* also Colotomy.  
condylomata of, 339.  
diphtheria of, 343.  
diseases of, 338.  
fissure of, 342.  
fistula of, 340.  
imperforate, 321, 323.  
excision of coecyx in, 327.  
operation for, 323, 324, 325, 326.  
narrowing of, 322, 323.  
occlusion of, 321, 323, 324.  
diagnosis of, 321, 323, 324.  
operations for, 323, 324, 325.  
pruritus of, 338.  
stricture of, 343.  
syphilitic affections of, 339.  
vegetations of, 340.  
warts of, 340.
- Anvil-shaped uterus, 747.
- Aphasia from gastric catarrh, 37.
- Apoplexy, 853.
- Apparatus for fractured clavicle, 1061.  
for spinal curvature, 1012.  
for wry-neck, 987.  
in fracture of femur, 1086.  
in spondylitis, 1038.
- Appearance of bone in hip-joint disease, 1158.
- Appendicitis, 282, 298.  
frequency of, 291.  
statistics of, 287, 298, 299.
- Appendicular peritonitis, 282.
- Appendix vermiformis, anatomy of, 285.  
disease of, 282. *See* Perityphlitis.  
foreign bodies in, 248.  
in perityphlitis, 290.  
location of, 286.  
removal of, 310.
- Appetite in acute entero-colitis, 138.  
in constipation, 200.  
in dyspepsia, 15, 16.  
in leukaemia, 786.
- Application for pain in a joint, 1257.  
of osteoclasis, 1277.
- Approximation of flaps in amputation, 1316.
- Argentii nitras in dyspepsia, 19.
- Aristol, note on, 702.
- Arm amputations, 1322.  
supernumerary, 938.
- Arnott's case of fractures in a family, 1048.
- Arrest of hemorrhage in amputation, 1315.
- Arsenic in anaemia, 777.  
in dyspepsia, 16, 21.  
injected into the spleen, 801.  
in leukaemia, 796.
- Arsenic-poisoning, 860.
- Arthroctomy of knee, 1214.
- Arthritis, 1128. *See*, also, the names of the principal joints.  
acute, in infants, 1237.  
of minor joints, 1256.
- Arthro-meningitis, 1127.
- Arthroctomy, 1218.
- Articular abscess, 1152.  
inflammation, 1127, 1139.
- Articulations, disease of. *See* the names of the principal joints.  
minor, diseases of, 1252.
- Artificial anaemia, 1261.  
anus after colotomy, 359.  
prognosis after, 363.  
statistics of, 363.  
feeding of infants, its great dangers, 64.  
respiration, 847.  
scab, 843.
- Ascariides, 224.  
causing abscess of liver, 477.  
diagnosis of, 226.  
eggs of, 226.  
in the bile-ducts, 419.  
lumbricoid, 224.  
prognosis in, 226.  
santonin for, 226.  
treatment of, 226.
- Ascaris lumbricoides, 224.  
description of, 224.  
diagnosis of, 226.  
effects of, 225.  
habitat of, 225.  
in abdominal cavity, 226.  
in abscesses, 226.  
in air-passages, 226.  
mischief done by, 225.  
symptoms of, 225.
- Ascites, 511.  
anatomical features of, 512.  
causes of, 511.  
complications of, 512.  
definitions of, 511.  
differentiation of, 513.  
etiology of, 511.  
names of, 511.  
pathology of, 512.  
prognosis of, 513.  
surgery of, 514.  
symptoms of, 512.  
synonymes of, 511.  
treatment of, 514.  
varieties of, 511.  
with chronic peritonitis, 279, 280.
- Asepsis for wounds, 841.  
in laparotomy, 261.  
*versus* antiseptic, 123.
- Ashby, Dr. H., on peritonitis, 268.
- Ashhurst, Dr. J., on fracture of scapula, 1062.
- Aspiration of pancreatic cysts, 393, 394.

- Aspiration in synovitis, 1135.  
 Asthenia as a cause of gastric dilatation, 43.  
 Astragalus-excision in club-foot, 976.  
 Astringents in acute dyspeptic diarrhoea, 124.  
   in entero-colitis, 146.  
 Asymmetry, congenital, in spinal curvature, 1003.  
   in wry-neck, 981.  
 Athrepsia neonatorum as favoring gastric hemorrhage, 56.  
   intestines in, 94.  
 Atmospheric conditions favoring diarrhoeal disease, 66, 67.  
   heat not the direct cause of diarrhoea, 69.  
 Atony of the stomach a cause of its dilatation, 42, 43.  
 Atresia ani urethralis, 336.  
   vesicalis, 333, 335.  
   vaginalis, 333, 334.  
   hymenalis, 749.  
   of rectum, 322, 324, 331, 333.  
   of urethra, 637.  
   of vagina, 716, 749.  
 Atrophic cirrhosis, 494.  
 Atrophy in hip-joint disease, 1165.  
   infantile, intestines in, 94.  
 Atropine for wry-neck, 986.  
 Attitude in caries, 1028.  
   in wry-neck, 983.  
 Auscultation of the dilated stomach, 47.  
 Autopsies showing intestinal lesions, 75, 77.  
 Autopsy after diarrhoeal disease, 84, 87.  
 Avulsion in fractures, 1047.
- B.**
- Bacillus anthracis in the blood, 766.  
   of green diarrhoea, 184.  
   tuberculosis in the blood, 76.  
 Bacteria, abnormal intestinal, 183.  
   antagonistic species of, 177.  
   as causes of disease, 183.  
   as specific factors in disease, 183.  
   collection of intestinal, 174.  
   destruction of, 195.  
   distributed in cow's milk, 70.  
   faecal, 170.  
   history of, 170.  
   inconstant, 177, 182.  
   in constipation, 199.  
   in diarrhoeal disease, 62, 70, 72.  
   in faeces of milk-fed infants, 175, 176.  
     uniformity of, 182.  
   in living and dead tissues, 75.  
   in milk, 189.  
   in stools, 100.  
   intestinal, 72.  
     of children, 170.
- Bacteria in their relations to other etiological factors in diarrhoeal diseases, 72.  
   in their relation to intestinal lesions, 74.  
   literature of, 170.  
   meconial, 174-176.  
   obligatory, 176, 178.  
   of children, intestinal, 170.  
   of cholera infantum, 130.  
   of diarrhoea described, 187.  
   of health *versus* those of disease, 189.  
   of the proteus group, 187.  
   of milk-faeces, 175, 176, 182.  
   of summer diarrhoea, 182, 186.  
   pathogenic, 73, 188.  
   poisonous species of, 73, 188.  
   post-mortem spread of, 79.  
   potential, 177, 182.  
   their entrance into the intestine, 173.  
   their relations to bile, 189.  
 Bacterial diarrhoea, 108. *See* Diarrhoea, Acute Mycotic.  
   influence upon digestion, 181.  
 Bacterium of acid diarrhoea, 185.  
   coli commune, 178, 180.  
   culture of, 179.  
   its functional differences from bacterium lactis aërogenes, 180.  
   variations in, 179.  
   lactis aërogenes, 178, 179.  
   in the intestine, 180.  
   morphology of, 178.  
   pathogenic qualities of, 178.
- Bad feeding a cause of gastric catarrh, 34.  
 Badly-united fractures, osteotomy in, 1285.  
 Baginsky on chlorosis, 777.  
 Baginsky's views on bacteria, 173, 180, 185.  
 Balanitis, 700.  
   exanthematous, 706.  
 Balano-posthitis, 700.  
   causes, 700.  
   course, 701.  
   croupous, 703.  
   diphtheritic, 703.  
   phlegmonous, 702.  
   symptoms, 700.  
   treatment, 701.
- Bandage, Esmarch's, 1314.  
 Bandages, 842.  
   in club-foot, 965.  
 Bard on leukaemia, 794.  
 Barker on after-treatment of hip-disease, 1201.  
 Barton on head of femur broken, 1083.  
 Barton's bandage in jaw fracture, 1056.  
 Barwell on pyæmic joint-affections, 1264.  
 Barwell's dressing for spine, 1013, 1014.  
 Base-low's disease in chlorosis, 782.  
 Bathing, 17.
- Bathing in diarrhoea, 114.  
   in dyspepsia, 14.  
 Baths in cholera infantum, 132.  
 Beach on elbow fracture, 1074.  
 Beck's fracture statistics, 1046.  
 Becquerel on blood in chlorosis, 780.  
 Beef juice, 115.  
   peptonoids, 115.  
   raw, in entero-colitis, 145.  
   tape-worm, 220, 221.  
 Beely's club-foot apparatus, 965.  
 Belching of gases in gastric dilatation, 44.  
 Bell on fracture of head of femur, 1083.  
   on separation of epiphysis of humerus, 1064.  
 Belladonna-poisoning, 862.  
 Bellamy on fracture of humerus, 1066.  
   on ulna fractures, 1081.  
 Belly in gastric dilatation, 45.  
 Benign fungus of the testicle, 699.  
 Benzoate of sodium for acute dyspeptic diarrhoea, 122.  
 Berlin-wool truss, 238.  
 Bernard's discoveries regarding functions of pancreas, 369.  
 Berry on rapid union of fractured clavicle, 1060.  
 Bibliography of children's diseases, 423.  
   of diarrhoeal diseases, 161.  
   of diseases of the ovary and tubes, 740.  
   of pancreatic diseases, 401.  
   of perityphlitis, 313, 314.  
 Bicornis uterus, 747.  
 Bidwell on fracture of condyle of humerus, 1071.  
 Bienstock's observations on bacteria, 172.  
 Bigelow's litholapaxy, 623.  
 Bile and bacteria, 189.  
   in blood, 765.  
   its effect on fat, 369.  
   not destructive to bacteria, 72.  
   source of, in icterus neonatorum, 406-408.  
 Bile-duct, cyst of, 378.  
   defects of, as causes of grave icterus neonatorum, 410.  
   evolution of, 410.  
 Bile-ducts in grave icterus neonatorum, 409.  
 Bilharzia hæmatobia, 768.  
   in anaemia, 773.  
 Biliary acids in the blood, 765.  
   calculus as a cause of pancreatic obstruction, 387.  
   disturbances due to pancreatic calculus, 387.  
   ducts, catarrh of, 418.  
     diseases of, 418.  
     pathology of, 418.  
   fistula at umbilicus, 412.  
 Bipartite uterus, 744.  
 Bird pancreas of, 367, 368.  
 Bird's-nest sternum, 1010.  
 Birth, blood-changes after, 405.  
   changes in fetal circulation at, 405, 406.

- Birth, fracture during, 1052.  
     of clavicle in, 1059.  
     of femur in, 1082.  
     luxations during, 1099.  
 Bismuth in entero-colitis, 146,  
 148.  
     its value in acute dyspeptic  
     diarrhœa, 121.  
     subnitrate for simple diar-  
     rhœa, 108.  
 Bite, femur fractured by, 1085.  
 Bites, 858.  
     of animals, 889.  
 Bizzozero's chromo-cytometer,  
 762.  
 Black stools due to bismuth,  
 121.  
 Bladder, absence of, 671.  
     diseases of, 674.  
     double, 671.  
     extrophy of, 658.  
     irritability of, 675.  
     causes, 675.  
     diagnosis, 676.  
     prognosis, 676.  
     treatment, 676.  
     malformations of, 633.  
     opened in hip abscess, 1191.  
     stone in, 596.  
     tumors of the, 679.  
     diagnosis, 680.  
     pathology and morbid  
     anatomy, 679.  
     prognosis in, 680.  
     symptoms of, 680.  
     treatment of, 681.  
 Bland's pill of iron, 782.  
 Bleeding early in leukæmia,  
 785.  
     from gums and teeth,  
     496.  
 Blindness after gastric hemor-  
 rhage, 57.  
 Blood, acetone in, 765.  
     ammonia in, 765.  
     amount of, 755.  
     appearance of, in leukæmia,  
     783.  
     bacillus anthracis in, 766.  
     tuberculosis in, 766.  
     characteristics of, 755.  
     chemical changes in, 764.  
     tests for, 58.  
     classification of diseases of,  
     768.  
     diminution of amount, 770.  
     diseases of, 755.  
     examination, 789.  
     Griffith's method, 789.  
     Huber's method, 789.  
     fatty acids in, 766.  
     fibrin in, 756.  
     filaria in, 767.  
     fœtal, 405.  
     hæmoglobin in, 756, 765.  
     in chlorosis, 779.  
     in dyspepsia, 3.  
     in joints, 1138.  
     in leukæmia, 787.  
     in lymphatic anæmia, 803.  
     in pernicious anæmia, 813.  
     in stools, 98, 100.  
     in urine, 526.  
     parasites in, 766.  
     peptone in, 766.  
     plaques in, 756.  
     plasma, 756.  
     Blood, plasmodium malarie in,  
     767.  
     red blood-cells, 756.  
     specific gravity, 755.  
     sugar in, 766.  
     uric acid in, 766.  
     white blood-cells, 757.  
     Blood-cells distorted, 763.  
     estimating, 760.  
     Blood-changes at birth, 405.  
     causing constipation, 197.  
     in the morphotic elements,  
     762.  
     Blood-corpuscles before and af-  
     ter birth, 405.  
     Blood-making apparatus, dis-  
     eases of, 755.  
     Blood-oozing, 866.  
     Blood-poison and Bright's dis-  
     ease, 533.  
     Blood-stream, fœtal, 403.  
     Blood-vessels, effects of toxic  
     ptomaines on, 75.  
     Bloody stools from intussuscep-  
     tion, 143.  
     in entero-colitis, 138.  
     Bodies, foreign, in the intes-  
     tine, 247. *See, also, Foreign  
     Bodies.*  
     Body-heat, conservation of, dur-  
     ing operations, 260, 319.  
     Body-weight and the blood,  
     755.  
     "Boggy" joint, 1259.  
     Bone, abscess in, 993, 1145.  
     acute inflammation of,  
     992.  
     deformities of, 1273.  
     ankylosis of, 1285.  
     application of osteo-  
     clasis for, 1277.  
     of osteotomy for,  
     1281.  
     definition and history  
     of osteoclasia for,  
     1273.  
     definition of osteotomy  
     for, 1279.  
     introductory remarks  
     on, 1273.  
     manual osteoclasia for,  
     1274.  
     osteoclasia for, 1273.  
     when advisable,  
     1273.  
     when not advisa-  
     ble, 1279.  
     osteotomy for, 1279.  
     for special cases  
     of, 1284.  
     history of, 1279.  
     in anterior tibial  
     curvatures,  
     1294.  
     in bow-leg, 1293.  
     in club-foot, 1297.  
     in elbow ankylosis,  
     1288.  
     division in amputation,  
     1315.  
     excision in club-foot, 976.  
     forceps for, 1314.  
     marrow in leukæmia, 791.  
     scalpel for, 1282.  
     Bone-building, 1035.  
     Bones of foot, luxation of, 1126.  
     Bony ankylosis, 1271.  
     Booker, Dr. W. D., on intesti-  
     nal bacteria of children, 170.  
     Bothrioccephalus latus a cause of  
     anæmia, 773.  
     Bottle, infant's feeding-, 105.  
     Bottle-fed infants, mortality  
     among, 64.  
     Bottle-feeding a cause of gas-  
     tric catarrh, 34.  
     Bottled milk, 104.  
     Bouchut, separated epiphysis of  
     humerus, 1063.  
     Bouillon-cultures for bacteria,  
     188.  
     Boulimia in dyspepsia, 6.  
     Bowel. *See Intestine.*  
     contents after acute croup-  
     ous inflammation, 87.  
     Bowels, hemorrhage from, 859.  
     in dyspepsia, 3, 4, 7, 15,  
     19.  
     Bow-leg, osteotomy in, 1293.  
     Box-splint for elbow, 1074.  
     Brackett, Dr. E. G., on club-  
     foot, 955.  
     on mechanical treatment  
     of deformities of infantile  
     paralysis, 1298.  
     on torticollis, 979.  
     Bradford, Dr. F. H., on club-  
     foot, 955.  
     Brain, compression of, 854.  
     concussion of, 854.  
     disorder, unconsciousness  
     from, 851.  
     in chronic diarrhœa, 95.  
     injuries to, 854.  
     lesions in acute diarrhœal  
     disease, 89.  
     Breast, absence of, 753.  
     Breast-feeding protects against  
     bacterial poisoning, 73.  
     Breast-milk in diarrhœas, 115.  
     in dyspepsia, 2.  
     Breasts, deformities of, 750.  
     Breathing in anæsthesia, 926.  
     Breslau's observations on bac-  
     teria, 174.  
     Brieger's observations on bac-  
     teria, 172.  
     Brick-burner's anæmia, 773.  
     Bright red stools, 98.  
     Bright's disease, 525, 532.  
     acute, 533.  
     age in, 536.  
     chronic, 555.  
     complications of, 548.  
     course of, 542.  
     convulsions in, 537.  
     diagnosis of, 546.  
     dropsy in, 538.  
     duration of, 542.  
     etiology of, 533.  
     heart in, 539.  
     pathological anatomy  
     of, 534.  
     polyuria in, 538.  
     pyrexia in, 538.  
     retina in, 540.  
     skin in, 540.  
     symptoms of, 537, 555.  
     synonyms of, 533.  
     thirst in, 538.  
     treatment of, 550.  
     urine in, 538.  
     vomiting in, 538.  
     Brisement forcé, 1270.



- Broad tape-worm, 220, 221.  
 Broncho-pneumonia in acute diarrhoeal disease, 89.  
 Broths for diarrhoea patients, 115.  
 Brown stools, 98.  
 Brown's wry-neck apparatus, 987.  
 Brunner on epiphysis separated at elbow, 1080.  
 Bruns on detachment of upper epiphysis of humerus, 1063, 1064.  
 Bryant on pelvic fracture, 1059.  
   on trochanter of femur separated, 1084.  
 Buchner's views on intestinal bacteria, 177.  
 Bunge, blood in chlorosis, 780.  
 Burns, 854.  
   weak granulations of, 843.  
 Bursitis, 1169.  
 Butler on fracture of styloid process, 1080.
- C.**
- Cadet's estimates of corpuscles in the new-born, 769.  
 Cæcal calculi, 288.  
   disease from constipation, 199.  
   inflammation, 282.  
   stones, 288.  
 Cæcum, abnormality of, 318.  
   anatomy of, 285.  
 Calculus, biliary, leading to pancreatic obstruction, 387.  
   cæcal, 288.  
   pancreatic, 383.  
     forming cyst, 387.  
     leading to liver-disease, 387.  
     removal of, 396.  
   preputial, 632.  
   prostatic, 631.  
   renal, 572.  
   urethral, 632.  
   vesical, 596.  
     after-effects of, 616.  
     age in, 598.  
     anaesthesia in sounding, 606.  
     anatomy of, 600.  
     cement in, 598.  
     complications of, 614.  
     congenital, 596.  
     cutting for, 609.  
     diagnosis of, 605.  
     facial expression in, 604.  
     failure to enter the bladder in cutting for, 614.  
     failure to find the stone, 615.  
     frequency of, 596.  
     hemorrhage in cutting for, 615.  
     heredity in, 596.  
     lateral lithotomy for, 609.  
     median lithotomy for, 613.
- Calculus, vesical, occupation as a cause, 599.  
 operations for, 608.  
 pain in, 604.  
 peritonitis in, 615.  
 poverty a cause, 600.  
 reflexes in, 604.  
 sounding in, 606.  
 sterility after, 616.  
 symptoms of, 604.  
 tenesmus in, 605.  
 urine retained in the operation, 615.  
 wounding the rectum in operation for, 614.
- Calomel, its value in acute dyspeptic diarrhoea, 121.  
 Campbell on fracture of humerus, 1066.  
 Canal of Nuek in hernia, 235.  
   of Wirsung, 366.  
 Cancer of the blood, 794.  
   of liver, 457.  
   of ovary, 739.  
   of pancreas, 396.  
   of rectum, 354.  
   of stomach, 54. *See* Gastric Cancer.  
   of testicle, 698.  
   of uterus, 717.  
 Cane-sugar, effect of pancreatic juice on, 370.  
 Canniff on radius-fracture, 1078.  
 Caput obstipum, 979.  
 Carbolic acid in dyspepsia, 20.  
   poisoning, 837, 860.  
 Carcinoma, dermoid, 801.  
   of liver, 457.  
   of pancreas, 396.  
   of stomach, 54. *See* Gastric Cancer.  
   of vagina, 725.  
 Carden's thigh-amputation, 1331.  
 Cardiac symptoms in dyspepsia, 10.  
 Cardialgia, 25.  
 Care needed in examining for injuries, 840.  
   of feeding-bottle, 105.  
 Caries, cervical, 1028.  
   dorsal, 1031.  
   lumbar, 1033.  
   neurotic, 1022.  
   sicca, 1022.  
   with torticollis, 985.  
 Carpal bones, 1082.  
   fractures of, 1082.  
 Carpus, amputations of, 1318.  
 Carrion-odor in liver-disease, 443.  
 Cartilage, separation of, in nose, 1054.  
 Cartilaginous ankylosis, 1266.  
 Cascara sagrada for constipation, 206.  
 Casein, deficiency in, a cause of fracture, 1048.  
   digestion of, 181.  
   in stools, 99.  
 Castor oil in dysenteric enterocolitis, 146.  
 Casts, intestinal, 163.  
 Catarrh, acute desquamative, of the intestines, 80.  
   appearances in, post mortem, 80.  
   athrepsia in, 80.  
   autopsies after, 80.  
   gastric, 8, 32, 33.  
   acute, 33. *See* Gastric Catarrh.  
   gastro-intestinal, 8, 108.  
   *See* Diarrhoea, Acute Mucocytic.  
   in anæmia, 776.  
   intestinal, a cause of perityphlitis, 290.  
   chronic, following acute, 91.  
   desquamative, 163.  
   *See* Membranous Enteritis.  
   due to bacteria and ptomaines, 74.  
   of the stomach, 19.  
 Catarrhal dyspepsia, 19.  
 Catarrhal inflammation, acute, 81.  
   in dyspepsia, 3.  
 synovitis, 1128.  
 type of dysenteric disease, 140.  
 ulcers of intestine, 83.  
 urethritis, 706.  
 vulvo-vaginitis, 718.
- Cat-bite, 858.  
 Cathartics for simple diarrhoea, 108.  
 Cells of blood, estimation of, 760.  
 Cementing matter in calculus, 598.  
 Centipede-sting, 858.  
 Cephalohæmatomata a cause of anæmia, 774.  
 Cereomonas in the blood, 810.  
 Cerebral hemiplegia and scoliosis, 1007.  
 Cervical caries, 1028.  
   vertebræ imperfect, 989.  
 Chairs for spinal curvature, 1015.  
 Change of air in chronic diarrhoea, 160.  
   for diarrhoeas, 113.  
 Changes, post-mortem intestinal, 78.  
   in the skeleton, influence of, in amputations, 1311.  
 Chapelain-Durocher on detachment of upper epiphysis of humerus, 1063.  
 Chapin, Dr. H. D., on functional diseases of liver, etc., 403.  
 Chart (I.) of cases of diarrhoea as compared with temperature, facing 66.  
 (II.) of cases of diarrhoeal diseases showing mortality under five years of age, facing 66.  
 (III.) showing relation between temperature and mortality in diarrhoeal diseases in Berlin, facing 68.

- Chart (IV.) showing relation between temperature and mortality in diarrhoeal diseases in Baltimore, facing 68.
- Chemical changes in the blood,** 764.
- Chemistry of infantile stools,** 96, 97.
- Chest-diseases and the liver,** 426.
- Children, intestinal bacteria of,** 170.
- Children's Hospital in Basle,** statistics of fractures, 1046.  
of Philadelphia, statistics of fractures, 1046.  
joints imperilled by violence, 1252.
- Chloral in children,** 13.
- Chloral-poisoning,** 861.
- Chloranæmia,** 777.
- Chlorate of potassium a cause of anæmia,** 772.
- Chloroanæmia,** 777.
- Chloroform,** 914.  
early history of, 914.
- Chlorosis,** 777.  
anatomical features of, 780.  
a primary anæmia, 781.  
blood in, 779.  
causes of, 777.  
complications of, 781.  
constipation a cause of, 199.  
definition of, 777.  
diagnosis of, 782.  
due to constipation, 199.  
etiology of, 777.  
names of, 777.  
pathology of, 780.  
prognosis in, 782.  
rubra, 778, 780.  
state of the blood in, 779.  
symptoms of, 778.  
synonyms of, 777.  
treatment of, 782.
- Cholemia,** 756.
- Cholera infantum,** 108, 126.  
*See, also, Diarrhoea, Acute Myotic.*  
bacteria in, 130.  
baths in, 132.  
causes of, 126.  
complications of, 133.  
diagnosis of, 130.  
discriminated from acute dyspeptic diarrhoea, 112, 130.  
discriminated from gastro-enteritis, 130.  
etiology of, 126.  
hygienic treatment of, 133.  
hyperpyrexia of, 132.  
hypodermic medication in, 132.  
ice in, 133.  
kidneys in, 129.  
nervous symptoms in, 128.  
nourishment in, 133.  
opium in, 132.  
pathology of, 130.  
prognosis in, 131.
- Cholera infantum, prophylaxis against,** 131.  
prostration in, 127, 133.  
sclerema following, 129.  
stimulants in, 133.  
stools in, 127.  
symptoms of, 127.  
temperature in, 128, 133.  
treatment of, 131.  
vomiting in, 127, 133.
- Chondroma of the testicle,** 699.
- Chopart's tarso-metatarsal amputations,** 1327.
- Chorea from phimosis,** 639.  
in chlorosis, 781.
- Chromo-cytometer,** 762.
- Chronic Bright's disease,** 555.  
catarrhal inflammation following acute disease of intestine, 91.  
diarrhoea, 149. *See Diarrhoea, Chronic.*  
diseases leading to gastric catarrh, 35.  
hyperplasia of the lymph-nodes, 91.  
infectious inflammations, 1258.  
gonorrhoeal, 1263.  
gouty, 1263.  
metastatic, 1264.  
of joints, 1264.  
osteo-myelitic, 1262.  
pyæmic, 1264.  
rheumatic, 1263.  
syphilitic, 1263.  
tuberculous, 1258.  
inflammation of intestine. *See Inflammation.*  
muco-colitis, 163. *See Membranous Enteritis.*
- Chylification, defects of, as causing constipation,** 197.
- Chyluria,** 529.  
treatment of, 529.
- Chymification, defects of, as causing constipation,** 197.
- Cicatrices a cause of spinal curvature,** 1005.
- Cicatrization,** 873.
- Circulation, effects of constipation on,** 199.  
foetal, 403, 404.  
unconsciousness due to, 851.
- Circumcision and calculus,** 599, 632.  
for preputial stone, 599, 632.  
in phimosis, 643.  
operation, 643.
- Circumscribed peritonitis,** 274.
- Circumstances acting to develop tubercle in bone,** 1141.
- Cirrhose du foie,** 488.
- Cirrhosis of the liver,** 488.  
malarial, 501.  
of stomach distinguished from pyloric stenosis, 40.
- City children with diarrhoeal disease,** 101.
- Clark, Sir Andrew, his views on membranous enteritis,** 167.
- Clark, Sir Andrew, on chlorosis,** 781.  
on shoulder fracture, 1064.
- Clarke on fracture of humerus,** 1067.
- Classes of bone tuberculosis,** 1143.
- Clavicle, fracture of,** 1059.  
both bones involved, 1061.  
death from, 1061.  
during birth, 1059.  
from convulsion, 1059.  
incomplete, 1059.  
intra-uterine, 1059.  
non-union in, 1060.  
Sayre's method for, 1061.  
treatment of, 1061.  
union after, 1060.  
luxations of, 1101.  
acromial, 1103.  
both ends involved, 1103.  
congenital, 1102.  
sternal, 1101.
- Cleanliness of the -feeding-bottle,** 105.  
of the nurse, 105.  
of the penis, 641.
- Cleansing of wounds,** 842.
- Clonic wry-neck,** 984.
- Clothing in cases of diarrhoea,** 114.  
in dyspepsia, 15, 17.  
in gastric catarrh, 34.
- Club-foot,** 955.  
anatomy of, 958.  
causation of, 955.  
definition of, 955.  
diagnosis of, 963.  
etiology of, 955.  
flat-foot a variety of, 961.  
acquired, 961.  
non-deforming, 963.  
osteotomy for, 1297.  
pes cavus, 962.  
prognosis, 964.  
synonyms, 955.  
talipes, 955.  
calcaneus, 960.  
equino-varus, 958.  
equinus, 960.  
varus, 955.  
Sayre's method in, 964.  
treatment of, 964.
- Club-hand,** 936.
- Clysiatna causing perityphlitis,** 289.
- Clyster. See Enemata.**
- Coats of intestine,** 76.
- Cocaine from tenesmus,** 149.
- Coecyx, excision of, in imperforate anus,** 327.
- Cochin-China diarrhoea,** 773.
- Cod-liver oil in anæmia,** 777.  
in chlorosis, 783.  
in constipation, 207.  
in dyspepsia, 15, 21.  
in leukiemia, 796.
- Cold as a cause of diarrhoea,** 66.  
as a cause of gastric catarrh, 34.  
bathing in chlorosis, 782.  
effects of, 856.

- Colds due to gastric disorder, 31.
- Colic, hepatic, how distinguished from gastralgia, 28.  
renal, 574.
- Colitis, 134. *See* Entero-Colitis, Acute.  
membranous, 163. *See* Membranous Enteritis.
- Collapse after wound, 868.  
in cyclical vomiting, 23, 24.
- Colles's fracture, 1080.
- Collins's osteoclast, 1276.
- Collodion, 845.
- Colloids in calculus, 598.
- Collum distortum, 979.
- Colon, dilatation of, 48.  
distended from constipation, 196, 201, 206.  
formation of cysts in, 93.  
in acute croupous inflammation, 88.  
irrigation of, 119.  
mobility of, 318.  
rudimentary, 318.
- Colonic dyspepsia, 163. *See* Membranous Enteritis.
- Color of stools, 97.
- Colotomy, 357.  
anaesthesia in, 260, 358.  
artificial anus after, 359.  
asepsis in, 358.  
finding the bowel in, 360.  
for imperforate anus, 329.  
indications demanding, 364.  
inguinal, 360, 362.  
instruments for, 260, 358.  
left lumbar, 328, 358.  
lumbar, advantages and disadvantages of, 362.  
meconium in, 358, 359.  
method of, 358.  
of the groin, 260, 328.  
operation of, 358.  
prognosis after, 363.  
results of, 362.  
right lumbar, 328, 360, 361.  
statistics of, 363.  
when justifiable, 357.  
when requisite, 361.  
*See also* Laparotomy.
- Comma-bacillus in cholera, 71.
- Comminuted fractures, 1049.
- Compensatory wry-neck, 980.
- Complete fractures, 1049.
- Complications in fracture of humerus, 1066.  
in hip-disease, 1191.
- Compound fractures, 1049.  
of femur, 1090.  
luxation of hip, 1119.  
wrist-luxations, 1115.
- Compression for effusion in a joint, 1258.  
of the brain, 854.
- Concretions, fecal, 1287.
- Concussion of the brain, 854.
- Conditions of the blood altered, 762.
- Condylar fractures of elbow, 1071.
- Condyle and epicondyle, 1070.
- Condyles, confusion as to, 1070.
- Condylo-mata, 339.  
of vulva, 727.
- Confusion in the names of condyles, 1070.
- Congenital abnormalities of the extremities, 929.  
of the large intestine, 317.  
of the small intestine, 315.  
asymmetry in spinal curvature, 1003.  
calculi, 597.  
club-hand, 937.  
club-foot. *See* Club-Foot.  
contraction of digits, 943.  
deficiency in extremities, 933.  
hypertrophy of extremities, 930.  
luxation of the knee, 1123.  
malformations, 321.  
of rectum, 321.  
supernumerary digits, 938.  
limbs, 938.  
torticollis, 979.  
union of digits, 941.
- Congestion of the brain. *See* Brain.  
of the liver, 430.
- Consciousness, loss of, 851.
- Conservation of heat during surgical operations, 260, 319.
- Conservatism in joint-inflammations, 1260.
- Constipation, abdominal distention with, 196, 201.  
acute and chronic anæmia with, 191, 207.  
anatomical considerations in, 192.  
appetite in, 200.  
bacterial influences in, 199.  
cachexia due to, 201.  
cascara sagrada in, 206.  
causes of, 194.  
causing convulsions, 198.  
perityphilitis, 290.  
chlorosis after, 199.  
chronic, 196, 198, 201, 203.  
circulation affected by, 199.  
cod-liver oil in, 207.  
complications with, 207.  
congenital, 203.  
defined, 191.  
diagnosis of, 202.  
diarrhoea with, 201.  
diet in, 205, 206.  
due to blood-changes, 197.  
changes in secretion, 197.  
constriction, 196.  
habit, 195, 199.  
medication, 195.  
nervous affections, 196.  
organic disease, 195.  
paralysis, 196.  
peritoneal affections, 196.  
reflex intestinal paralysis, 197.  
spasm, 197.  
effects of, 198.  
effects of, on the abdominal glands, 215.  
electricity for, 207.  
enemata for, 204, 206.  
etiology of, 194.
- Constipation, food as causing, 206.  
in treatment of, 205.  
foods causing, 194.  
frequency of, 193.  
from mechanical obstruction, 198.  
glycerin for, 206.  
habitual, 196, 198, 201, 203.  
headaches from, 202, 206.  
history of, 191.  
in children, its peculiarities, 192.  
in dyspepsia, 7, 21.  
in gastric dilatation, 45.  
in peritonitis, 270, 271.  
infantile, defined, 193.  
jaundice from, 200.  
literature of, 191.  
massage for, 207.  
medication in, 205.  
nervous symptoms from, 199.  
non-medical cure for, 205.  
nurslings with, 200, 201.  
pathology of, 198.  
physiological aspects of, 192.  
prognosis of, 202.  
suppositories for, 204.  
symptoms of, 200.  
treatment of, 203.
- Constitutional disturbances depending on pyæmia, 910.  
on sarræmia, 908.  
on septic germs present in suppuration, 908.  
on septicæmia, 909.
- Constriction, obstructive abdominal, 267.  
of intestine causing constipation, 195.
- Constrictions, congenital, of the intestine, 268.
- Contagiousness of diarrhoeal disease, 66.
- Contents of intestine in diarrhoeal diseases, 82.
- Continuous extension in hip-disease, 1181.
- Contracted digits, 943.  
treatment of, 944.
- Contractility of intestines, exaggerated, a cause of constipation, 197.
- Contractions of the liver, 488.
- Control of hemorrhage in amputation, 1314.
- Contused wounds, 884.
- Contusions, 857.  
of hip, 1169.
- Convalescence from enterocolitis, 149.
- Convulsions, 851, 853.  
causing fracture of clavicle, 1059.  
of femur, 1085.  
due to constipation, 198, 202.  
in Bright's disease, 537, 552  
in gastric catarrh, 36.
- Cooper on fracture of neck of femur, 1084.  
on separation of epiphysis of humerus, 1064.

- Coverer spinal, 1030.  
 Coprosteals, how distinguished from paratyphlides, 300.  
 Cord, hydroneur, of, 692.  
 Cornea, transplanting, 855.  
 Corneal ulcers in chronic diarrhoea, 456.  
 Corona ovarium, 736.  
 Coronoid process, fracture of, 1075.  
 Corpuscles in the blood, 756.  
   estimation of, 760.  
   of blood before and after birth, 405.  
 Coryza due to disorder of stomach, 31.  
 Cotting on smashed face, 1057.  
 Cotton under a bandage, 816.  
 Cranium, fracture of epidural, 1071.  
   fracture of forearm, 1076.  
   fracture of lower part of humerus, 1063.  
   head of femur broken, 1063.  
   rib fractures, 1053.  
   study of fractures, 1040.  
 Councilman, Dr. W. T., on parasites in the intestinal canal, 217.  
 Counter irritation in dyspepsia, 12, 19.  
 Cousters, 979.  
 Cow's milk as infant food, 2, 61, 62, 103.  
   diarrhoea from, 61, 65.  
   impurities in, 55.  
   in diarrhoeas, 115.  
   in dyspepsia, 11.  
   sterilization of, 2.  
 Coxalgia, discriminated from paratyphlides, 301.  
 Cracks of bones, 1059.  
 Crassula in dyspepsia, 19.  
 Cranium in fracture, 1053.  
 Criniform hymen, 719.  
 Cripps, Harrison, his views on the reduction of intussuscepted bowel, 259.  
 Cross leg, 1186.  
 Croup of the intestines, 163.  
   *See Membranous Enteritis*.  
 Croupous bilious posthitis, 703.  
   inflammation of the intestine, acute. *See Acute Croupous Inflammation, methritis*, 707.  
 Cryptorchidism, 670.  
 Cubito palmar club hand, 927.  
 Cuboid luxated, 1126.  
 Cul de sac, anal, 331.  
   rectal, 332.  
 Culture media of intestinal bacteria, 186, 188.  
 Curvatura, lateral, distinct from Pott's disease, 1069.  
 Curvatures of the spine, 1061.  
 Cyanosis afebrilis teterea per nichosa cum haemoglobinuria, 827.  
 Cyanotic discoloration, 829.  
 Cylindrical vomiting, 23.  
   bowels in, 23.  
   causes of, 23.  
   definition of, 23.  
   ejecta in, 23.  
   etiology of, 23.  
   medication in, 21.  
 Cylindrical vomiting, results of, 23.  
   stimulation in, 21.  
   symptoms of, 23.  
   treatment of, 21.  
 Cystos, 1019.  
 Cystosis, 1001.  
 Cyst, dermoid, 737, 738.  
   of bile duct, 378.  
   of liver, 125.  
   of pancreas, 383, 386. *See Pancreatic Cysts*.  
 Cystiferous in men, 720.  
 Cysts in the colon, 93.  
   of penis, 637.  
   of kidney, 632.  
   of testicle, 639.  
   of vagina, 724.  
 Cystitis, 676.  
   causes, 677.  
   diagnosis, 678.  
   pathology, 677.  
   prognosis, 678.  
   symptoms, 677.  
   treatment, 678.  
 Cytogenic anaemia, 770.
- D.
- Da Costa on leukaemia, 797.  
 Danger in violence to joints, 1252.  
   of both in haematuria, 551.  
   of breaking adhesions in joint disease, 1151.  
 Dangers of the high operation for stone, 621.  
 Davis's spinal assistant, 1039.  
 Deadly nightshade poisoning, 862.  
 Deafness in leukaemia, 785.  
 Death rate. *See Mortality*.  
 Deceased meat poisoning, 862.  
 Decomposition of food in acute dyspeptic diarrhoea, 120.  
 Deep inflammations, 345.  
 Dehabitated blood injections, 820.  
 Dehiscence of extremities, 533.  
 Deformities, 929.  
   of bone, 1273. *See Bone, Deformities of*.  
   of breast, 750.  
   of infantile paralysis, 1293.  
   of stomach, 60.  
 Deformity after hip disease, 1139.  
   from osteomyelitis, 1005.  
   in fracture, 1053.  
   in femur fracture, 1059.  
   in spinal curvature, 1002.  
   in spondylitis, 1021.  
   in wry neck, 931.  
 Degeneration, amyloid, 91.  
 Dehaen's catarrh, 1271.  
 Dehiscence, red corpuscles in the new born, 759.  
 Denatation as a cause of gastric catarrh, 31.  
 Denatation from, 109.  
   relation of, to diarrhoea, 51.  
 Dermal hemorrhages, 785.  
 Dermoid cysts, 737, 738.  
 Dermoid carcinoma, 891.  
 Despey on elbow fracture, medication in, 21.  
 Desquamative catarrh, acute, 79, 80.  
 Detached on fracture of femur, 1065.  
 Deviation in spine, ascending the, 1018.  
 Diaphragm, its position in gas free dilatation, 16.  
   rectal, 324.  
 Diaphragmatic hernia, 214. *See Hernia*.  
   paralytic as a cause of constipation, 196.  
 Diaphragmatic hernia, 996.  
 Diarrhoea alba laborum, 66.  
   acute. *See Catarrh, Intestinal*.  
   acute dyspeptic, 109.  
   acute in, 123.  
   alcoholic in, 121.  
   antiseptic medication in, 120.  
   antiphlogistic, 122.  
   arsenic in, 123.  
   asthenic in, 121.  
   bathing in, 111.  
   benzoate of sodium in, 122.  
   bismuth in, 121.  
   brack milk in, 115.  
   cuboid in, 121.  
   cutaneous in, 113.  
   causes of, 109.  
   change of air for, 113.  
   clinical history of, 109.  
   clothing in, 111.  
   complications of, 113.  
   course of, 109.  
   cow's milk in, 115.  
   diagnosis of, 111.  
   diabetic treatment of, 111.  
   dyspeptic ferment in, 125.  
   etiology of, 109.  
   excursions in, 113.  
   fermented milk preparations in, 116.  
   ferruginous in, 125.  
   fetus in, 110.  
   fever in, 115.  
   fresh air for, 113.  
   how distinguished from cholera infantum, 112, 120.  
   how distinguished from inflammatory diarrhoea, 117.  
   hygienic treatment of, 113.  
   ice water in, 118.  
   injections for, 120.  
   iodoform in, 121.  
   irrigation of the colon in, 119.  
   irrigation of the stomach in, 113.  
   milk in, 115.  
   naphthol in, 121.  
   narcotic in, 111.  
   opium in, 111.  
   potassium in, 125.  
   pathology of, 109.  
   peppermint in, 120.  
   peptonized milk in, 116.  
   prognosis in, 112.

- Diarrhoea, acute dyspeptic,** prostration in, 111.  
 putrefactive process in, 120.  
 relapses in, 110.  
 resorcin in, 122.  
 rules for feeding in, 116.  
 salicylate of sodium in, 122.  
 salol in, 121.  
 salt-water trips in, 113.  
 sodium benzoate for, 122.  
 sodium salicylate in, 122.  
 stimulants in, 125.  
 stomach-washing in, 118.  
 symptoms of, 109.  
 termination of, 110.  
 treatment of, 113.  
   in general, 126.  
   wet-nurse in, 115.
- acute mycotic,** 108.  
 medicinal treatment of, 117.  
 names of, 108.  
 synonyms of, 108.
- anaemia,** 774.
- bacterial,** 108. *See* Diarrhoea, Acute Mycotic.
- chronic,** 149.  
 forms of, 149.  
 milk diet in, 158.  
 primary cases of, 149.  
   antiseptics in, 159.  
   bismuth in, 159.  
   fatal cases of, 151.  
   how distinguished from secondary, 155.  
   in older children, 152.  
   opium in, 159.  
   prognosis of, 152.  
   recovery from, 151.  
   stimulants in, 159.  
   treatment of, 157, 158.
- Diarrhoea, chronic, secondary** cases of, 149, 152.  
 appearance in, 153.  
 appetite in, 153.  
 as a sequel of other diseases, 150.  
 astringents in, 159, 160.  
 bismuth in, 159.  
 causes of, 149.  
 change of air in, 160.  
 clothing in, 158.  
 colic in, 154.  
 complications in, 155.  
 corneal ulcers in, 155.  
 diagnosis of, 155.  
 diet in, 158.  
 drugs seldom curative in, 158, 159.  
 enemata in, 159, 160.  
 etiology of, 149.  
 flatulence in, 154.  
 from prolonged lactation, 150.
- Diarrhoea, chronic, secondary** cases of, how distinguished from primary cases, 155.  
 how distinguished from tuberculosis, 156.  
 infantile, symptoms of, 150.  
 mouth in, 153.  
 nervous symptoms in, 154.  
 nutrition in, 154.  
 overfeeding in, 158.  
 panerobiline in, 160.  
 prognosis in, 155, 157.  
 prolapsus ani in, 154.  
 prophylaxis of, 157.  
 pulse in, 154.  
 second attacks of, 150.  
 skin in, 154.  
 stimulants in, 160.  
 stools in, 151, 152, 153.  
 symptoms of infantile, 150.  
 temperature in, 154.  
 tongue in, 153.  
 treatment of, 159.  
 undetected cases, 151.  
 urine in, 154.  
 warmth in, 158.  
 weight in, 154.
- choliform,** 126. *See* Cholera Infantum.  
 bathing in, 14.  
 Cochin-China, 773.  
 fatty, 98, 99.  
 febrile, 163. *See* Membranous Enteritis.  
 fibrinous, 163. *See* Membranous Enteritis.  
 in dyspepsia, 4, 23.  
 in leukaemia, 785, 786.  
 in tabes mesenterica, 206.  
 infectious, 62, 108. *See* Diarrhoea, Acute Mycotic.  
 inflammatory, 134. *See* Enterocolitis, Acute.  
 mucous, 163. *See* Membranous Enteritis.  
 simple, 106.  
   causes of, 106.  
   definition of, 106.  
   etiology of, 106.  
   opium in, 108.  
   pathology of, 107.  
   symptoms of, 107.  
   treatment of, 108.  
   with constipation, 201.
- Diarrhoeal disease,** 61.  
 acute desquamative, 79, 80.  
 age of patients, 62.  
 anatomical features of, 75.  
 atmospheric conditions favoring, 66, 67.  
 bacteria in, 62.  
 bacteriology of, 61.  
 bibliography of, 161.  
 brain-lesions in, 89, 95.  
 breast-milk in, 64.  
 broncho-pneumonia in, 89.  
 causes of, 62, 64, 70, 103.
- Diarrhoeal disease, changes of** air or water a cause of, 67.  
 city children in, 101.  
 classification of, 61, 79.  
 cold as a cause, 66.  
 contagion of, 66.  
 constitutional predisposition to, 63.  
 cow's milk in, 103.  
 dentition in, 64.  
 diet in, 64.  
 disinfection in, 101.  
 due to bacteria, 70.  
 epidemics of, 68, 70.  
 etiology of, 62.  
 exposure as a cause, 66.  
 feeding in, 102, 103.  
 food in, 64, 65, 69, 102, 103.  
 foreign bodies as a cause, 66.  
 frequent feeding in, 103.  
 fruits in, 103.  
 heart in, 90.  
 home-life as influencing, 63.  
 hygiene of, 67, 69, 101.  
 improper foods in, 64, 65, 69, 103.  
 intussusception in, 90.  
 kidneys in, 90.  
 lesions of, in relation to bacteria and ptomaines, 71, 74.  
 liver in, 90.  
 lunches in, 103.  
 lungs in, 89.  
 manner of life as affecting, 67, 69, 101.  
 mesenteric glands in, 90.  
 micro-organisms in, 61.  
 mortality from, at different seasons, 68.  
 mouth in, 89.  
 overfeeding in, 102.  
 pathological anatomy of, 75.  
 pathological classification of, 79.  
 peritoneum in, 90.  
 predisposition to, 63.  
 prophylaxis of, 101.  
 ptomaines as influencing, 71, 74.  
 season of the year in, 68.  
 spleen in, 90.  
 stomach in, 90.  
 stools in, 95.  
 summary of the prophylaxis, 106.  
 surroundings as influencing, 63, 101.  
 telluric conditions favoring, 66.  
 toxic symptoms in, 71.  
 tuberculosis in, 90.  
 undigestible food as a cause, 66.  
 vegetable foods to be avoided in, 103.  
 weaning as a cause, 66, 69.

- Diarrhœal fœces, bacteria of, 186.
- Diathèse lymphogène, 801.
- Diathesis in dyspepsia, 3.  
verminosa, 218.
- Diathetic causes of Pott's disease, 1020.
- Dieffenbach's operation for wry-neck, 989.
- Diet. *See* also under the names of various diseases in this index.  
in albuminuria, 530.  
in dyspepsia, 14, 18.  
in gastralgia, 29.  
in simple diarrhœa, 108.
- Differential diagnosis of cases of intestinal obstruction, 267.  
diagnosis of pernicious anæmia, 819.
- Digestion as influenced by bacteria, 181.  
in dyspepsia, 18.  
of casein, 181.  
of milk, 181.
- Digestive ferments in acute diarrhœa, 123.  
system, diseases of, 1.
- Digits, amputation of, 1317, 1325.  
contracted, 943.  
deficient, 935.  
fused, 935.  
supernumerary, 938.  
united, 941.
- Dilatation of phimosis, 643.  
for stone, 617, 618.  
of the colon, 48.  
of the stomach, 41.  
acidity of stomach-contents in, 44.  
anatomical features of, 44.  
belching of gases in, 44.  
causes of, 42.  
complications with, 45.  
definition of, 41.  
diagnosis of, 45.  
diaphragm in, 45.  
diet in, 50.  
differential diagnosis, 47.  
due to adynamia, 43.  
due to chronic gastric catarrh, 43.  
due to pyloric stenosis, 43.  
due to tuberculosis, 43.  
eructations in, 44.  
etiology of, 42.  
external signs of, 45.  
fool-accumulation in, 50, 51.  
foods in, 50.  
gases eructated in, 44.  
gastric atony as a cause, 42, 43.  
history of, 41.  
how distinguished from ascites, 48.  
from intestinal catarrh, 48.  
from splenic enlargement, 47.
- Dilatation of the stomach in dyspepsia, 7.  
lavage in, 49.  
liver in, 46.  
medication in, 51.  
names of, 41.  
non-medicinal treatment of, 49.  
overfeeding a cause of, 44.  
palpitation in, 47.  
pathological anatomy of, 44.  
prognosis in, 48.  
recovery from, 48.  
rickets as a cause of, 42.  
skimmed milk in, 50.  
stenosis of the pylorus in, 40, 42.  
stomach-pump in, 50.  
symptoms of, 44.  
synonymes of, 41.  
treatment of, 48.  
vomiting in, 44.
- Diminutive penis, 635.
- Diphtheria of anus, 343.  
anæmia after, 772.
- Diphtheritic balanoposthitis, 703.  
causes of, 704.  
course of, 704.  
symptoms of, 703.  
treatment of, 704.  
gastritis, 30.  
vuivo-vaginitis, 723.  
treatment of, 723.
- Diseases of digestive system, 1.  
of the stomach, 30.  
functional, 1.
- Disinfection of foods, 105.  
of stools, 101.
- Dislocation in hip-joint disease, 1100.  
of hip, congenital, 1173.
- Dislocations, 1043, 1097. *See*, also, Luxations.  
congenital, 945.  
definition, 945.  
diagnosis, 952.  
etiology, 946.  
history, 945.  
in hip-joint disease, 1100.  
of hip, 1173.  
pathology, 949.  
prognosis, 953.  
symptoms, 950.  
synonymes, 945.  
treatment, 953.
- Disordered stomach, 32.
- Disorders of stomach, functional, 1.
- Displacements of stomach, 59.
- Dissection wounds, 898.
- Distention of abdomen from constipation, 196, 201.  
in hernia, 240.  
of stomach in pyloric stenosis, 40, 42.
- Distorted blood-cells, 763.
- Diuretics in Bright's disease, 551.
- Diverticula of intestine, false, 317.
- Diverticulum, Meckel's. 316.  
*See* Meckel's Diverticulum.
- Doehmius duodenalis in anæmia, 773.
- Dog-bites, 858.
- Dogs and hydatid, 446.
- Dorsal caries, 1031.
- club-hand, 937.  
scoliosis, 1011, 1012.  
vertebræ, luxations of, 1100.
- Dorsey on fracture at elbow, 1073.
- Double bladder, 671.  
fracture of clavicle, 1060.
- Drainage in abscesses of joints, 1155.  
in pancreatic abscess, 385.  
in wounds, 879.
- Dress in dyspepsia, 15, 17.
- Dressing for injuries, 841.  
of wounds, 843.
- Drink, increase of, in summer, 106.
- Dropsy, 512, 553.  
abdominal, 511. *See* Ascites.  
in Bright's disease, 538.  
in liver-disease, 445.
- Drowning, 847.
- Drowsiness in leukæmia, 786.
- Drugs as causes of diarrhœa, 107.  
not curative in chronic diarrhœa, 158, 159.
- Drunkard's liver, 488.
- Duclon on chlorosis, 781.
- Duct, pancreatic, 366.
- Ductus venosus in icterus neonatorum, 407.
- Duer on coronoid fracture, 1075.
- Dulles, Dr. Charles W., on minor surgery and emergencies in children, 839.
- Duncan on blood in chlorosis, 779.
- Dunn on forearm-fracture, 1078.
- Duodenal dyspepsia, 163. *See* Membranous Enteritis.
- Duodenitis a cause of icterus, 415, 417.
- Duodeno-cholecystotomy, 379.
- Duplex uterus, 745.
- Dupuytren's amputation at the shoulder, 1324.
- Dysentery, 134.  
characters of, 62.  
name not a desirable one, 61, 62.  
not a specialized and definite disease, 62.  
objections to the term, 135.  
*See* Entero-Colitis, Acute.
- Dysmorph-osteo-palin-klastes, 1275.
- Dyspepsia, 1.  
acidity of stomach in, 6.  
acute, 4, 5, 9, 12, 14.  
appetite in, 5, 6.  
arsenic in, 16, 21.  
blood in, 3.  
boulimia in, 6.  
bowels in, 3, 4, 7, 19.  
breast-milk in, 2.  
carbolic acid in, 20.  
cardiac complications in, 10.  
catarrhal, 8, 19.  
inflammation in, 3.

- Dyspepsia, causes of, 2.  
 chronic, 5, 6, 9, 10, 16.  
 clothing in, 15, 17.  
 cod-liver oil in, 15, 21.  
 colonic, 163. *See* Mem-  
 branous Enteritis.  
 constipation in, 7, 21.  
 counter-irritations in, 12,  
 19.  
 creasote in, 19.  
 diagnosis of, 9-11.  
 diarrhoea in, 4, 33.  
 diathesis in, 3.  
 diet in, 14, 18.  
   causing, 3.  
 digestion in, 18.  
 disposition in, 8.  
 dress in, 15, 17.  
 duodenal, 163. *See* Mem-  
 branous Enteritis.  
 effects of, 5, 11.  
 emetics in, 13.  
 exercise in, 17.  
 fever in, 8, 13.  
 flatulence in, 7.  
 follicular, 163. *See* Mem-  
 branous Enteritis.  
 fontanel in, 5.  
 food in, 2, 3, 13, 18.  
   gastric secretions in, 3.  
   heart in, 10.  
   hepatic complications in,  
   10.  
 hydrocephaloid symptoms  
 in, 6.  
 hygienic in, 16.  
 infantile, milk-supply in, 2.  
 inherited, 3.  
 intercurrent diseases in, 9,  
 10.  
 inunctions in, 14.  
 iron in, 16, 21, 22.  
 its discrimination from  
   syphilis, 9.  
   from tuberculosis, 10,  
   11.  
 jaundice in, 11.  
 kidneys in, 10.  
 lactic acid in, 123.  
 lavage in, 6.  
 lesions in, 3, 4.  
 liver in, 10.  
 mastication of food in, 3.  
 meals in, 18.  
 medication in, 15, 19.  
 milk in, 2, 14.  
 mucous membrane in, 4.  
 nature of, 1.  
 nausea in, 6.  
 nervous, 7.  
   disorders in, 36.  
   symptoms in, 11.  
 nitrate of silver in, 16, 19.  
 nurse in, 2.  
 pain in, 7.  
 pathology of, 3.  
 pepsin in, 13, 20.  
 predisposing causes of, 3.  
 prognosis in, 11.  
 pulse in, 8.  
 renal complication in, 10.  
 rest in, 17.  
 results of, 11.  
 sanitation in, 3.  
 skin in, 5, 14.  
 stimulants in, 16, 21.  
 stomach in, 7, 8, 13.
- Dyspepsia, stools in, 7.  
 strychnia in, 20.  
 sulphurous acid in, 20.  
 symptoms of, 4, 9.  
 temper in, 8.  
 thirst in, 5.  
 throat in, 9.  
 tongue in, 5, 6, 8, 13.  
 tonics in, 16.  
 treatment of, 11.  
 urine in, 8, 19.  
 vomiting in, 5, 6, 12.  
 weakness in, 16.  
 wet-nurse in, 2.  
 worms in, 6.
- Dyspeptic diarrhoea, acute, 109.  
 Dyspnoea in leukaemia, 786.  
 in pernicious anaemia, 811.
- E.
- Eames, olecranon-fracture, 1674.  
 Ear, foreign body in, 851.  
 Earle, Dr. C. W., on acute and  
 chronic constipation, 191.  
 Early indications in wry-neck,  
 984.  
   pregnancy, 750.  
   sexual development, 750.  
   treatment of club-foot, 964.  
 Eating between meals a cause  
 of diarrhoeas, 103.  
 Echinomoses, 496.  
   in fracture, 1053.  
 Echinococcus cysts, 220.  
   in hydatid, 447.  
 Ecstasy of the stomach, 41.  
 Ectopia testis, 695.  
 Ectopion vesicae, 658.  
 Ectromélie, 933.  
 Edwards, Dr. W. A., on mem-  
 branous enteritis, 163.  
 Effects of cold, 856.  
   of heat, 854.  
 Eggs of ascarides, 226.  
 Egg-water, 115.  
 Egyptian chlorosis, 773.  
 Ehrlich, on the action of the  
 blood in leukaemia, 788.  
 Elbow-joint, acute inflamma-  
 tion of, 1244.  
   amputations, 1321.  
   ankylosis, 1288.  
   disease, 1244.  
   excision in, 1246.  
   symptoms of, 1244.  
   treatment of, 1245.  
   tubercular disease of, 1245.  
 Elbow-luxations, 1106.  
   both bones, 1106.  
   causes, 1106.  
   compound, 1109.  
   incomplete, 1108.  
   reduction of, 1107.  
   symptoms, 1106.  
   radius alone, 1110.  
     reduction of, 1107.  
   head of radius back-  
   ward, 1112.  
   outward, 1112.  
   ulna alone, 1113.  
 Electricity for constipation, 207.  
 Elephantiasis of the labia, 728.  
 Emaciation in anaemia, 774.  
 Embolism as a cause of gastric  
 hemorrhage, 56.
- Emergencies, 839, 847.  
 drowning, 847.  
 foreign body in the ear,  
 851.  
   in the eye, 850.  
   in the nose, 851. *See*,  
   also, Foreign Bodies.  
 intoxication, 852.  
 strangulation by a foreign  
 body, 849.  
   by hanging, 849.  
 suffocation with gases, 849.  
 to decide cause of uncon-  
 sciousness, 852.  
 unconsciousness, 851.
- Emetics as a cause of peri-  
 phlitis, 289.  
 Empyema a cause of spinal  
 curvature, 1005.  
 deformity from, 1006.  
 scoliosis from, 1005.
- Emulsifying power of pancre-  
 atic juice, 369.
- Encephaloid cancer a cause of  
 fracture, 1048.  
 Endocarditis in chlorosis, 782.  
 Enemata for constipation, 204.  
   nutrient, in dilatation of  
   the stomach, 51.
- Enlarged spleen, 798.  
 Ensiform cartilage displaced,  
 1103.
- Enteritis as a cause of intes-  
 tinal obstruction, 264.  
   membranous, 163. *See*  
   Membranous Enteritis.  
   pseudo-membranous, 163.  
   *See* Membranous Enter-  
   itis.
- Entero-colitis, acute, 134.  
 abdomen in, 138.  
 age of patients in, 141.  
 antiseptics in, 146.  
 appetite in, 138.  
 astringents in, 146.  
 bismuth in, 146, 148.  
 bloody stools in, 138.  
 castor oil in, 146.  
 catarrhal, 140.  
 causes of, 134.  
 circulation in, 136.  
 clysters in, 147.  
 colon, washing of, in,  
 147.  
 complications of, 142.  
 convalescence from,  
 145, 149.  
 croupous, 139.  
 death from, 141.  
 diagnosis of, 142.  
 dietetics of, 144.  
 digestion in, 145.  
 discriminated from in-  
 tussusception, 142.  
 duration of, 140.  
 dysenteric form of, 134.  
 emaciation in, 139.  
 enemata in, 147.  
 erythema in, 142.  
 etiology of, 134.  
 follicular ulceration in,  
 140.  
 forms of, 134.  
 fruits to be avoided in,  
 145.  
 furuncles in, 142.  
 glands in, 142.

- Entero-colitis, acute, hospitals for, 144.**  
 hygiene of, 144.  
 irrigation of bowel in, 147.  
 its development from a simple diarrhoea, 113.  
 local treatment in, 147.  
 lymph-nodes in, 140.  
 magnesium silicate in, 146.  
 medication in, 145.  
 milk diet in, 145.  
 mouth in, 137, 142.  
 mucus in stools of, 138.  
 names of, 134.  
 nervous symptoms in, 137.  
 nutrition in, 139.  
 opium in, 144, 146.  
 overfeeding in, 147.  
 overfeeding in, 145.  
 poultices in, 147.  
 previous condition, 140.  
 prognosis in, 141, 143.  
 prolapsus ani in, 139.  
 prophylaxis in, 143.  
 pulse in, 136.  
 pus in stools of, 138.  
 rectal injections, 147.  
 irrigation in, 147.  
 shreds in stools of, 133.  
 skin in, 142.  
 stimulants in, 147.  
 stomatitis in, 142.  
 stools in, 137.  
 subacute type of, 139, 147.  
 symptoms of, 134.  
 synonyms of, 134.  
 table of ulcerative cases, 140.  
 talcum in, 146.  
 temperature in, 136, 140.  
 termination of, 141.  
 time of year in, 143.  
 tongue in, 137.  
 tonics after, 149.  
 treatment of, 143.  
 urine in, 139.  
 varieties of, 134, 139.  
 vegetable diet to be avoided in, 145.  
 vomiting in, 137.  
 weight in, 139.
- Entero-cystomata, 317.**  
**Enterorrhaphy for congenitally occluded bowel, 320.**  
**Entire upper extremity amputation, 1324.**  
**Enuresis, 591.**  
 causes of, 591.  
 innervation in, 592.  
 masturbation in, 593.  
 treatment of, 594.
- Eosin, action of, with the blood in leucæmia, 788.**  
**Eosinophilen Zellen, 788.**  
**Eosinophilous cells, 788, 795.**  
**Epicondyle, fractures of, 1070.**  
**Epidemic hæmoglobinuria of the new-born, 827.**  
 with icterus in the new-born, 827.
- Epidemics of diarrhoeal disease, 68, 70.**  
**Epididymitis, 697.**  
 causes of, 697.  
 course of, 697.  
 symptoms of, 697.  
 treatment of, 698.
- Epigastric tumor as a sign of cancer of the pancreas, 398.**  
**Epileptic fits, 853.**  
**Epileptiform seizures, how distinguished from gastralgia, 28.**  
**Epiphyses in early life, 1139.**  
 of joints in periostitis, 998.  
 of tibia, separation of, 1096.  
**Epiphysal disjunction, 1050, 1069, 1084, 1096.**  
**Epiphysis in hip-joint disease, 1139.**  
 of greater trochanter, separation of, 1084.  
 of humerus, separation of, 1069.
- Epiphysitis, 1228.**  
**Epispadia, 655.**  
 complications of, 656.  
 diagnosis of, 657.  
 etiology and pathology of, 655.  
 prognosis of, 657.  
 treatment of, 657.
- Epistaxis a cause of anæmia, 774.**  
**Epithelial cells in stools, 99.**  
**Epithelium in acute diarrhoeal disease, 78, 83.**  
 intestinal, its disappearance after death, 78.  
 renewal of, 84.
- Epitrochlea, fractures of, 1071.**  
**Équino-varus, 958.**  
**Erethismus ventriculi, 25.**  
**Erosion of vertebræ, 1021, 1022.**  
**Erosions of the mucosa, microscopic, 83.**  
**Eruptions from the dilated stomach, 44.**  
**Erysipelas, 907.**  
 in fracture of femur, 1086.  
 in wounds, 869.
- Erythema in entero-colitis, 142.**  
**Erythrocytes, increase of, 770.**  
**Escherich's investigations regarding the bacteria, 173, 174, 175, 179, 182, 187.**  
 rules for feeding, 115.
- Esmarch's bandage, 1314.**  
 Lister's rules for use of, 1333.  
 case of separated epiphysis of humerus, 1063.
- Essential febrile anæmia, 808.**  
**malignant anæmia, 808.**  
**perniciosa anæmia, 808.**
- Ether, 913.**  
 early history, 913.
- Etiology. See, in this index, under the names of the various diseases.**
- Evacuations in childhood, normal, 193.**  
**Examination for spinal curvature, 1009.**  
 for spondylitis, 1027.  
 of case of periostitis, 995.
- Examination of intestines, post-mortem, 75, 77.**  
 of liver, 424.  
 of specimens, 816.
- Examining for an injury, 840.**  
**Exanthemata, joint-affections after, 1135.**  
 periostitis simulating, 994.
- Exanthematous balanitis, 706.**  
 course of, 706.  
 treatment of, 706.  
 inflammation of ovaries and tubes, 739.
- Excess of blood, 769.**  
 of development of the genitals, 759.
- Excessive growths, 920.**  
 labor and chlorosis, 778.
- Excision in hip-disease, 1194.**  
 of bone in club-foot, 976.  
 of coccyx in imperforate anus, 327.  
 of elbow, 1246.
- Exciting cause of tubercle, 1142.**  
**Excursions, their benefits in cases of diarrhoea, 113.**
- Exercise, 17.**  
 in anæmia, 776.  
 in dyspepsia, 17.
- Exposure to cold as a cause of diarrhoeal disease, 66.**  
**Exstrophy of the bladder, 658.**  
 diagnosis of, 659.  
 diversion of the urine in, 660.  
 mechanical treatment of, 659.  
 plastic closure of the opening in, 661.  
 prognosis in, 659.  
 treatment of, 659.
- Extension in femur-fracture, 1087.**  
 in hip-disease, 1150, 1173.  
 in spondylitis, 1036.  
 in synovitis, 1137.
- External dressing in wounds, 881.**
- Extra-capsular abscess, 1152.**  
 fracture of femur, 1084.
- Extra-peritoneal operation for right iliac abscess, 311.**
- Extremities, congenital abnormalities of, 929.**  
 contraction of the digits, 943.  
 club-hand, 937.  
 deficiency, 933.  
 hypertrophy, 930.  
 supernumerary digits, 938.  
 thumbs, 938.  
 union of the digits, 941.
- Eye, foreign body in, 850.**  
 splinters in, 858.
- Eyes unequal, a cause of wry-neck, 980.**
- F.
- Face, dressings for, 815.**  
 fractures of bones of, 1054.  
 smashed, 1057.  
 tint of, in splenic anæmia, 799.
- Factors in arthroctomy, 1217.**



- Factors in tubercular deposit, 1158.
- Factory-girls and chlorosis, 778.
- Fæcal concretions, 287.
- Fistula, congenital, 318.
- tumors, 202, 207.
- Fœces in appendix and cæcum, 287.
- in dressings of hip-disease, 1192.
- of diarrhoea, bacteria in, 184, 186.
- quantity of, 193.
- See Chlorosis.
- Fæge on chlorosis, 777.
- Fainting, 851.
- Fallopian tubes, abnormalities of, 743.
- blood in, 716.
- False ankylosis, 1266.
- diverticulum of intestine, 317.
- membrane in stools, 100.
- membranes in enteritis, 166.
- Farabeuf on separation of lower epiphysis of humerus, 1069.
- Farneaux on hip-amputation, 1333.
- Fat in the blood, 765.
- in the stools, 99.
- Fat-diarrhoea, 99.
- Fat-digestion in jaundice, 415.
- Fats, effect of pancreatic juice on, 369.
- non-absorption of, in chronic diarrhoea, 160.
- Fatty acids in the blood, 766.
- foods injurious in gastric dilatation, 51.
- liver, bibliography, 439.
- diagnosis of, 439.
- prognosis of, 439.
- treatment of, 439.
- stools as a sign of pancreatic cancer, 397.
- as a sign of pancreatic disease, 390.
- in jaundice, 415, 416.
- Fayrer on rib-fracture, 1053.
- Feeding in diarrhoeal disease, 102.
- Feeding-bottles, 105.
- Feeding-tube condemned, 105.
- Feeling tired, 1256.
- Felons, 844.
- Female, external genitalia of, 711.
- genital organs, abnormalities of, 741. See also names of the different organs.
- diseases of, 711, 731. See also names of the different organs.
- excess of development in, 750.
- stone in, 617.
- Femora, softening of, 1049.
- Femoral hernia. See Hernia.
- Femur absent, 934.
- fractures of, 1082.
- amputation for, 1092.
- compound, 1090, 1091.
- deformity in, 1089.
- Femur, fractures of, during birth, 1082.
- extension in, 1087.
- extra-capsular, 1084.
- in birth, 1082.
- intra-uterine, 1082.
- of great trochanter, 1084.
- of lower epiphysis, 1091.
- of neck of, 1084.
- plaster bandages in, 1086.
- refracture, 1089.
- separation of epiphysis, 1082.
- of upper epiphysis, 1083.
- shaft, 1084.
- shortening, 1086.
- splints for, 1086.
- spontaneous, 1085.
- treatment of, 1086.
- union in, 1088.
- vertical extension in, 1088.
- luxations of, 1116.
- Fenger, Dr. Christian, on perityphlitis, paratyphlitis, and perityphlitic abscess, 282.
- Fermentation, intestinal, its varieties, 180, 181.
- of food as a cause of stomach-dilatation, 42.
- Fermented preparations of milk in diarrhoea, 116.
- Ferments, digestive, in acute diarrhoeas, 125.
- pathogenic. See Bacteria and Ptomaines.
- Ferrari's osteoclast, 1277.
- Fever from cyclical vomiting, 23.
- in chlorosis, 779.
- in wounds, 869.
- Fevers followed by arthritis, 1129.
- Fibrin, exudation of, in croupous inflammation of intestine, 88.
- in blood, 756.
- Fibrinous diarrhoea, 163. See Membranous Enteritis.
- Fibroma of vagina, 724.
- Fibrous ankylosis, 1267.
- Fibula deformed or absent, 934.
- luxations of, 1126.
- Filaria, 529.
- in the blood, 767.
- sanguinis hominis in anæmia, 773.
- Filix mas for tape-worm, 223.
- Finger, amputations of, 1317.
- luxations of, 1115.
- sprain of, 856.
- Fingers deficient, 935.
- Fish-hooks in the flesh, 857.
- Fissure of the anus, 342.
- Fissures of bones, 1050.
- Fistula, artificial pancreatic, 394.
- at umbilicus, biliary, 412.
- congenital fecal, 318.
- perineal, 333.
- recto-vaginal, 331.
- 334.
- urethral, 654.
- Fistula in ano, 340.
- incomplete, 342.
- Fits, epileptic, 853.
- Fixative apparatus in spondylitis, 1038.
- Flap-approximation in amputation, 1316.
- Flaps, formation in amputation, 1315.
- Flat-foot, 961, 977.
- osteotomy for, 1297.
- Flatulence in dyspepsia, 7.
- in leukæmia, 786.
- Fleischl's hamometer, 759.
- Fletcher on olecranon-fracture, 1075.
- Floating kidney, 522.
- Flour-ball, 116.
- Fluor albus, 717.
- Flush of cheeks in leukæmia, 786.
- Flushing joint of knee, 1208.
- of bowel or stomach. See Irrigation.
- Fœtal circulation, 403, 404.
- liver, 403, 404.
- lungs, 403.
- Fœtus, icterus of, 406.
- Follicles of Lieberkühn, 78.
- Follicular dyspepsia, 163. See Membranous Enteritis.
- ulceration in entero-colitis, 140.
- of intestines, 84.
- ulcers of intestine, diagnosis of, 141.
- healing of, 93.
- Food. See also Diet.
- improper, a cause of diarrhoea, 107.
- indigestible, causing perityphlitis, 289.
- in dyspepsia, 13, 18.
- its adaptation to the age of the child, 65.
- Food-remains in stools, 99, 138.
- Foods causing constipation, 194.
- improper, 73, 103, 194.
- as tending to promote development of the bacteria in the intestine, 73.
- impure, 104.
- in diarrhoeal disease, 102.
- preparation of, 105.
- Foot after removal of toes, 1325.
- Foot-bones, luxations of, 1126.
- Force in club-foot, 972.
- Forcible correction in wry-neck, 986.
- manipulations in joint-disease, 1151.
- Forearm, amputations of, 1320.
- fractured in birth, 1076.
- fractures, 1076.
- both bones, 1076.
- incomplete, 1076.
- radius alone, 1079.
- ulna alone, 1081.
- luxations, 1106.
- splint for, 846.
- Foreign bodies a cause of diarrhoea, 107.
- in the cæcum and appendix, 288.
- in the ear, 851.
- in the eye, 850.

- Foreign bodies in the intestine, 247.  
 in the nose, 851.  
 in the rectum, 356.  
 in the throat, 849.  
 in the vermiform appendix, 248.  
 in the vulva, 730.
- Formation of cysts in the colon, 93.
- Formulae, their day gone by, 62.
- Foster on gastralgia in chlorosis, 779.
- Foulerton on fracture of clavicle, 1062.  
 on radius-fracture, 1079.
- Fowler, Dr. G. S., on anomalies of the kidney, 516.
- Fractures, 1043.  
 badly-united, osteotomy in, 1285.  
 casein-deficiency in, 1048.  
 causes of, 1047.  
 comminuted, 1049.  
 complete, 1049.  
 complicated, 1049.  
 compound, 1049.  
 crepitus as a sign of, 1053.  
 deformity as a sign of, 1053.  
 during birth, 1052.  
 ecchymosis as a sign of, 1053.  
 epiphysal disjunction, 1050, 1069, 1084, 1090.  
 etiology of, 1047.  
 fissured, 1049.  
 forearm, 1076.  
 fragility of bones in, 1047.  
 green-stick, 777.  
 heredity in, 1049.  
 immediate causes, 1047.  
 impacted, 1049.  
 incomplete, 777.  
 intra-uterine, 1051.  
 liability of bones to, 1945.  
 loss of power a sign, 1052.  
 mobility a sign, 1053.  
 mode of repair, 1053.  
 multiple, 1049.  
 of anatomical neck of humerus, 1063.  
 of bones of face, 1054.  
 of carpal bones, 1082.  
 of clavicle, 1059.  
 of condyle of humerus, 1072.  
 of coronoid process, 1075.  
 of epicondyle, 1070.  
 of epitrochlea, 1071.  
 of femur, 1082. *See* Femur.  
 of fibula, 1093.  
 of foot-bones, 1097.  
 of forearm, 1076. *See* Forearm.  
 of great trochanter, 1084.  
 of hand, 1082.  
 of humerus, 1062.  
 of leg-bones, 1093.  
 of lower extremity, 1082.  
 of lower part of humerus, 1067.  
 of neck of femur, 1084.  
 of neck of humerus, 1063, 1065.  
 of olecranon, 1074.  
 of scapula, 1062.
- Fractures of separation of lower epiphysis of humerus, 1069.  
 of shaft, 1065.  
 of femur, 1084.  
 of surgical neck of humerus, 1065.  
 of tibia, 1093.  
 of upper epiphysis of humerus, 1063.  
 of upper extremity, 1059.  
 of upper maxilla, 1055.  
 pain in, 1052.  
 partial, 1049.  
 phenomena and symptoms of, 1052.  
 predisposing causes of, 1047.  
 rickets a cause, 1048.  
 scrofula a cause, 1048.  
 separation of epiphyses in, 1083, 1091, 1096.  
 simple, 1049.  
 special, 1054.  
 sprain, 1049.  
 statistics of, 1046.  
 swelling of, 1053.  
 treatment of, 1054.  
 varieties of, 1049.  
 whooping-cough a cause, 1048.
- Fracture-box in children, 1094.
- Fragility of bones in fractures, 1047.
- Fraser on fracture of neck of humerus, 1063.
- Freezing, 856.
- Fremitus in hydatid, 451.
- Fresh air in anaemia, 776.  
 its importance in cases of diarrhoea, 113.
- Friedreich on chlorosis, 782.
- Fright a cause of wry-neck, 980.
- Frog, pancreas of larval, 368.
- Frog-belly, 45.
- Functional diseases of liver, 403. *See* Liver, Functional Diseases of.  
 disorders of stomach, 1.
- Functions of a joint, to restore, 1258.
- Fungi of umbilicus, 687.
- Fungous synovitis, 1128, 1136.
- Fungus of the testicle, 699.
- Funicular hernia, 236.
- Fuqua on separation of epiphysis of humerus, 1063.
- Fusion of kidney, 518.
- G.**
- Galvanism in wry-neck, 986.
- Ganglion of minor joints, 1256.
- Gangrene, 908.  
 after fracture, 1077.  
 of the tibia, 728.
- Gangrenous balano-posthitis, 705.  
 causes of, 705.  
 course of, 705.  
 symptoms of, 705.  
 treatment of, 705.
- Gases expelled from the dilated stomach, 44.  
 from infantile stools, 96.
- Gastralgia, 25, 1024.  
 age of patients in, 25.
- Gastralgia, attack of, 27.  
 causes of, 25.  
 definition of, 25.  
 diagnosis of, 27.  
 diet in, 29.  
 etiology of, 25.  
 history of, 25.  
 in chlorosis, 779.  
 names of, 25.  
 onset of, 27.  
 pathology of, 26.  
 periodicity in, 27.  
 sex in, 25.  
 symptoms of, 26.  
 synonyms of, 25.  
 tobacco a cause of, 26.  
 treatment of, 28.
- Gastroctasia, 41.
- Gastric cancer, 54.  
 age of patients, 54.  
 symptoms of, 55.
- catarrh, 1, 8, 32.  
 acute, 33.  
 alcoholics as a cause of, 33.  
 anatomical features of, 25.  
 anaemia as a cause of, 35.  
 anorexia in, 36.  
 aphasia in, 37.  
 as a cause of dilatation of the stomach, 43.  
 breath in, 36.  
 causes of, 34.  
 characters of, 33, 35.  
 complications of, 36.  
 convulsions in, 36.  
 definition of, 33.  
 diagnosis of, 37.  
 diet in, 38.  
 etiology of, 34.  
 food in, 38.  
 hemiplegia from, 37.  
 hot food and drinks as a cause of, 35.  
 icterus in, 36.  
 names of, 33.  
 nervous disorders in, 36.  
 pathology of, 33, 35.  
 pepsin in, 38.  
 prognosis in, 37.  
 pyrexia in, 35.  
 relapses in, 38.  
 respiratory organs in, 37.  
 symptoms of, 35.  
 synonyms of, 35.  
 temperature in, 35.  
 treatment of, 38.  
 types of, 35.  
 vomiting in, 36.  
 deformities, 60.  
 disorders, 1, 20. *See* Stomach, Diseases of.  
 displacements, 39. *See* Displacements of the Stomach.  
 dyspepsia in leukaemia, 786.  
 ectasy, 41.  
 hemorrhage, 55.  
 after malarial fever, 57.  
 blindness after, 57.

- Gastric hemorrhage, causes of, 56.  
 diagnosis of, 57.  
 due to blood-changes, 57.  
 from embolism, 56.  
 from portal obstruction, 56.  
 from ulcers, 53, 54, 56.  
 from venous stasis, 56.  
 in atresia neonatorum, 56.  
 Monsef's solution in, 59.  
 of the new-born, 56.  
 prognosis in, 58.  
 styptics in, 59.  
 symptoms of, 57.  
 tarry stools from, 57.  
 treatment of, 58.  
 varieties of, 56.  
 vomiting in, 59.
- secretions in dyspepsia, 1, 3.  
 symptoms in dyspepsia, 7, 8.  
 tonic, 501.  
 ulcer, 51.  
 age in, 53.  
 anatomical characters of, 52.  
 causes of, 52.  
 definition of, 51.  
 diet in, 54.  
 etiology of, 52.  
 hemorrhage from, 53.  
 in chlorosis, 781.  
 its diagnosis from gastralgia, 28.  
 its rarity in children, 31, 43.  
 medication in, 54.  
 morbid anatomy of, 52.  
 pathology of, 52.  
 prognosis in, 54.  
 symptoms of, 51.  
 treatment of, 54.  
 vomiting in, 54.
- Gastricismus, 33.  
 Gastritis, 32.  
 causes of, 32.  
 diphtheritic, 33.  
 lesions in, 32.  
 symptoms of, 32.
- Gastro-duodenitis a cause of icterus, 415, 417.  
 Gastrodynia, 25.  
 Gastro-enteritis, chronic pseudo-membranous, 163.  
*See* Membranous Enteritis.  
 how distinguished from cholera infantum, 130.  
 Gastro-entero-colitis, its development from a simple diarrhoea, 113.  
 Gastro-intestinal catarrh, 8.  
 derangements, their danger, 106.  
 secretions as affecting constipation, 197.
- Gastromalacia, 60.  
 names of, 60.  
 synonyms of, 60.
- Gastro-resonance, plessimetric, 46.  
 Gastrosis, 33.
- Gayraud on fracture of both forearms, 1078.  
 Gelatinous diarrhoea, 163. *See* Membranous Enteritis.  
 General prophylaxis of diarrhoeal disease, 101.  
 Genito-urinary organs, diseases of, 516.  
 Geographical distribution of leukaemia, 785.  
 Germs of diseases. *See* Bacteria.  
 destruction of, 105.  
 in periostitis, 994.
- Gerster, Dr. A. B., on deformities of bone, 1273.  
 on operation for hydrarthrosis, 1227.
- Gibney, Dr. V. P., on frequency of hip-joint disease, 1156.  
 on lateral and functional curvatures of the spine, 1001.
- Gibson on fracture of clavicle at birth, 1059.
- Gin liver, 488.
- Githens, Dr. W. H. H., on pernicious anaemia, 812.
- Glanders, 897.  
 diagnosis, 897.  
 incubation, 897.  
 treatment, 898.
- Glands in entero-colitis, 142.  
 in lymphatic anaemia, 804, 808.  
 intestinal, 76, 78, 79.  
 mesenteric, in tabes, 210.  
 removal of, in lymphatic anaemia, 808.  
 tuberculosis of, 211.  
 tubular, in acute croupous inflammation of the intestine, 88.
- Glass-wounds, 858.
- Glisson on spinal curvature, 1001.  
 Glisson's swing in spinal curvature, 1002.
- Glomerular nephritis, 535.
- Glossocomium Nymphodori, 1273.
- Glycerin in the treatment of constipation, 206.
- Goddard's case of fractures in a family, 1049.
- Gonorrhoea of minor joints, 1263.
- Goodhart, Dr. J. F., on Bright's disease, 532.
- Gotthard-tunnel disease, 773.
- Gout of minor joints, 1263.
- Gowers's apparatus, 758.
- Graber on blood in chlorosis, 780.  
 on chlorosis, 781.
- Graham on fractures in a family, 1049.
- Granger on fracture of elbow, 1071.
- Granular kidney, 535, 555.
- Granulation, 872.
- Granulations of the umbilicus, 687.  
 treatment of, 687.
- Granulirte leber, 488.
- Gray on lower epiphysis of humerus, 1070.
- Gray stools, 98.
- Green diarrhoea, bacillus of, 184, 185.  
 infectious, 185.  
 varieties of, 184.
- Green-sickness, 777.
- Green-stick fracture, 1050.
- Green stools, 97.
- Grief a cause of wry-neck, 980.
- Griffe-pied creux, 963.
- Griffin on palatal fracture, 1057.
- Griffith, Dr. J. P. Crozer, on diseases of the blood and blood-making apparatus, 755.
- Groin, colotomy in the, 360.
- Gross, Dr. S. W., on extirpation of the spleen, 796.  
 fracture of clavicle, 1059.
- Gross appearances after acute catarrhal inflammation with non-epithelial lesions, 81.
- Ground-water, its fluctuations not related to the prevalence of diarrhoeal disease, 66.
- Growth, excessive, 930.
- Guitéras on lymphatic anaemia, 807.
- Gurlt on elbow-fracture, 1071.  
 on fracture of scapula, 1062.  
 on intra-uterine fracture of clavicle, 1059.
- Gurlt's table, 1045.
- Gut-perforation in hip-disease, 1191.
- Gymnastics, medical, 1015.

## H.

- Habit as causing constipation, 195, 199, 205.
- Habitual indigestion, 5, 6, 9, 10.
- Haemacytometers, 760.
- Haematemesis, 55.  
 how distinguished from haemoptysis, 58.  
 in leukaemia, 785.
- Haematocele, 694.  
 treatment of, 694.
- Haematosalpinx with atresia of vagina, 716.
- Haemato-spectroscope, 762.
- Haematuria, 526, 554, 581, 587.
- Haemin, test for, 58.
- Haemogenesis, defective, in chlorosis, 781.
- Haemoglobin in blood, 756.  
 estimation of, 758.  
 in pernicious anaemia, 813.  
 its conversion into biliary coloring-matter, 406.  
 transfer of, at birth, from the stroma of the red corpuscles to the plasma, 406.
- Haemoglobinæmia, 406, 407, 765.
- Haemoglobinometer, 758.
- Haemoglobinuria, 526.  
 infectious, 827. *See* Infectious Haemoglobinuria.
- Haemolytic anaemias, 772.
- Haemometer, 759.
- Haemophilia a cause of synovitis, 1138.  
 in anaemia, 774.

- Hæmophilia** in leukaemia, 787.  
**Hæmoptysis**, how distinguished from hæmatemesis, 58.  
**Hamilton** on coronoid fracture, 1075.  
 on detachment of upper epiphysis of humerus, 1063.  
 on fracture of condyle of humerus, 1071.  
 on fracture of maxilla, 1057.  
 on head of femur broken, 1083.  
 on olecranon fracture, 1074.  
 on tetanus after fracture, 1077.  
 on ulnar fracture, 1082.  
**Hand**, fracture of bones of, 1082.  
 club-hand, 937.  
 compound, 937.  
 simple, 937.  
 treatment of, 938.  
 varieties of, 937.  
**Hand-feeding**, dangers of, 65.  
**Hands**, deformed, 935.  
 rudimentary, 933.  
 supernumerary, 938.  
**Hanging**, 849.  
**Hare**, Dr. H. A., on diseases of the stomach, 30.  
**Hatfield**, Dr. M. P., on contractions of the liver, 488.  
**Hayem** on chlorosis, 781, 782.  
 on fever in chlorosis, 779.  
 on red corpuscles in the new-born, 769.  
**Hayem** and Lesage on the bacillus of green diarrhoea, 184.  
**Headache** due to constipation, 202, 206.  
**Head**, flexion of, 1016.  
 of femur separated, 1083.  
 of fibula luxated, 1126.  
 of radius luxated backward, 1112.  
 of radius luxated outward, 1112.  
 rotation of, 1016.  
**Healing** by first intention, 871.  
 by granulation, 872.  
 in wounds, 869.  
 of intestinal follicular ulcers, 93.  
 under a scab, 874.  
**Healthy organs** resist bacterial poisoning, 73, 74.  
**Heart**, dilated, 554.  
 in acute diarrhoeal disease, 90.  
 in Bright's disease, 539.  
 in chlorosis, 779.  
 in dyspepsia, 10.  
 small, in chlorosis, 777.  
**Heat**, conservation of, during operations, 260, 319.  
 effects of, 854.  
 in abscess, 1166.  
 in freezing, 836.  
**Heat-exhaustion**, 855.  
**Heat-stroke**, 855.  
**Helferich** on pinning in detached epiphysis of humerus, 1064.  
**Helmintology**, 217. *See* Parasites.  
**Hémimélie**, 933.  
**Hemiplegia** from gastric catarrh, 37.  
**Hemlock-poisoning**, 861.  
**Hemorrhage** a cause of anæmia, 774.  
 checking of, 501.  
 control of, 843.  
 in amputation, 1344.  
 from the stomach, 55.  
 in amputation, 1315.  
 in hip-disease, 1193.  
 in wounds, 869.  
 nuchal, 687.  
**Hemorrhages** in septic jaundice, 412.  
 special, 859.  
 from the bowels, 859.  
 from the lungs, 859.  
 from the nose, 859.  
 from the stomach, 55, 859.  
**Hemorrhagic diathesis** in leukaemia, 787.  
 icterus, 507.  
**Hemorrhoids**, 351.  
**Henoch's hæmato-spectroscope**, 762.  
**Henry** on blood in anæmia, 797.  
 on blood in chlorosis, 780.  
 on blood in pernicious anæmia, 813.  
 on chlorosis, 781.  
**Henry's examinations** of blood of the new-born, 769.  
**Hepatic abscess**, 466.  
 colic, how distinguished from gastralgia, 28.  
 symptoms in dyspepsia, 10.  
**Hereditary diathesis** in spinal curvature, 1004.  
 syphilis in dyspepsia, 9.  
 spleen in, 798.  
 syphilitic joint-affections, 1264.  
**Heredity** in calculi, 597.  
 in chlorosis, 777.  
 in deformities of the breast, 753.  
 in deformity, 936.  
 in excessive growths, 930.  
 in fracture, 1048.  
 in hernia, 237.  
 in leukaemia, 784.  
 in polydactylism, 939.  
 in spinal curvature, 1003.  
**Hermaphroditism**, 663.  
 diagnosis of, 669.  
 pathogenesis and etiology of, 665.  
 peculiarities of formation of, 665.  
 treatment of, 671.  
**Hernia**, 231.  
 causes of, 231.  
 congenital inguinal, 235.  
 anatomy of, 235.  
 of Haller, 236.  
 ovary in, 235.  
 testicle in, 235-237.  
 umbilical, 232.  
 apparatus for, 233-234.  
 binder for, 233.  
 cases of, 232.  
 causes of, 232.  
 diagnosis of, 233.  
**Hernia**, congenital umbilical.  
 operation for, 234.  
 prognosis of, 233.  
 spontaneous cure of, 233.  
 treatment of, 233.  
 definition of, 231.  
 diaphragmatic, 244.  
 encysted, 236.  
 femoral, 243.  
 rarity of, in children, 243.  
 diagnosis of, 244.  
 treatment of, 244.  
 funicular, 236.  
 hereditary, 237.  
 lumbar, 245.  
 of the uterus, 748.  
 predisposition to, 237.  
 race in, 237.  
 sex in, 237.  
 signs of, 231.  
 strangulated, 240.  
 artificial anus in, 241.  
 cases of, 242.  
 cure of, 241-243.  
 definition of, 240.  
 fistula from, 240.  
 operation for, 241.  
 radical cure of, 243.  
 symptoms of, 240.  
 taxis in, 241.  
 treatment of, 241.  
 through the linea alba, 235.  
 treatment of, 238.  
 truss for, 234.  
 varieties of, 231, 232, 236.  
**Herniosa hydrocele**, 692.  
**Hershey** on leukaemia, 797.  
**Hiatus** of the abdominal wall, 658.  
**High operation** for stone, 618.  
**Hip**, congenital dislocation of, 1173.  
 epiphysitis of, 1236.  
 symptoms of, 1236.  
 in paralysis, 1308.  
**Hip-joint amputations**, 1332.  
 ankylosis, osteotomy in, 1285.  
 disease, 1156.  
 abscess in, 1166, 1188.  
 adduction to correct, 1180.  
 altered position in, 1162.  
 amyloid degeneration in, 1192.  
 anæsthesia in diagnosis, 922.  
 complications of, 1191.  
 courses of, 1157.  
 definition of, 1156.  
 diagnosis of, 1168.  
 from muscular rheumatism, 1169.  
 divisions, 1157.  
 effect of, on the bone, 1158.  
 excision for, 1194.  
 extension in, 1173.  
 factors in, 1158.  
 fixation in treatment, 1175.

- Hip-joint disease, frequency of, 1156.  
 from bursitis, 1169.  
 from congenital dislocation, 1173.  
 from contusions and sprains, 1169.  
 from infantile paralysis, 1170.  
 from neuroses, 1169.  
 from peri-arthritis, 1170.  
 from perityphlitis, 301.  
 from sacro-iliac joint, 1170.  
 from vertebral caries, 1170.  
 general tuberculosis as a complication, 1193.  
 hemorrhage in, 1193.  
 intra-pelvic abscess in, 1188.  
 limitation of motion in, 1163.  
 long splint in, 1180.  
 manual osteoclasis in, 1274.  
 motion in treating, 1173.  
 muscular wasting in, 1164.  
 operation for, 1193, 1198.  
 by scraping, 1196.  
 pain in, 1161.  
 passive motion in, 1188.  
 perforation of gut, 1191.  
 quiet disease, 1168.  
 results of, 1188, 1198.  
 splint in, 1177.  
 stages of, 1160.  
 statistics of, 1189.  
 symptoms of, 1161.  
 treatment of, 1173.  
 of abscess, 1177.  
 true dislocation from, 1191.  
 luxations of, 1116.  
 dorsal, 1117.  
 reduction of, 1118.  
 symptoms of, 1118.  
 frequency of, 1116.  
 from disease, 1116.  
 into pubes, 1123.  
 into sciatic notch, 1120.  
 reduction of, 1121.  
 into thyroid foramen, 1121.  
 reduction of, 1121.  
 symptoms of, 1121.  
 signs of cure of, 1190.  
 spontaneous, 1116.  
 theory of, 1116.  
 traumatic, 1117.  
 varieties of, 1116.  
 voluntary, 1116.  
 with fracture, 1119.
- Hippuric acid, 500.  
 History of spinal curvature, 1001.  
 Hob-nailed liver, 488.
- Hodgkin's disease, 801.  
 splenic form of, 800.  
 Hofmekl on leg-fractures, 1082.  
 Holmes on death from hemorrhage in fracture of clavicle, 1061.  
 on fracture of clavicle, 1060.  
 Holt, Dr. L. E., on diarrhoeal diseases, 61.  
 Hopkins, Dr. Wm. B., on amputations, 1311.  
 Horse-shoe kidney, 518.  
 Hot bath in freezing, 856.  
 Hot food and drinks as a cause of gastric catarrh, 34, 35.  
 Hubbard, Dr. Le Roy W., on congenital dislocations, 945.  
 Huels on chlorosis, 782.  
 Huguier's view as to the place of the sigmoid flexure in the new-born, 328, 360.  
 Humerus, fractures of, 1062.  
 compound separation of epiphysis, 1064.  
 of anatomical neck, 1063.  
 of condyle, 1072.  
 of coronoid process, 1075.  
 of epitrochlea, 1071.  
 of lower epiphysis, 1069.  
 of lower part, 1067.  
 of olecranon, 1074.  
 of shaft, 1065.  
 of surgical neck, 1065.  
 of upper epiphysis, 1063.
- Humphrey on forearm-fracture, 1076.  
 Hunchback, 1031.  
 spine, 1022.  
 Hunt, Dr. W., on calculi, 596.  
 Hunter on pernicious anaemia, 813.  
 Hutchinson on fracture of surgical neck of humerus, 1065.  
 on luxations, 1098.  
 Hydatid of kidney, 584.  
 of liver, 425, 445.  
 anatomical characters of, 447.  
 bibliography of, 456.  
 diagnosis of, 452.  
 dogs a cause of, 446.  
 duration of, 454.  
 echinococcus in, 447.  
 fremitus in, 451.  
 frequency of, 445.  
 in Iceland and Australia, 446.  
 not rare in children, 446.  
 pressure - symptoms, 451.  
 prognosis of, 454.  
 rupture in, 451.  
 suppuration in, 451.  
 symptoms of, 448.  
 tenia in, 445.  
 treatment of, 455.  
 unknown in America, 446.  
 Hydræmia, 769.  
 Hydræmic plethora, 769.
- Hydrarthrosis, 1227.  
 definition of, 1227.  
 treatment of, 1227.  
 Hydrocele, 691.  
 of cord, causes of, 692.  
 prognosis of, 693.  
 symptoms of, 692.  
 treatment of, 693.  
 acupuncture, 693.  
 painting, 693.
- Hydrocephalus symptoms in dyspepsia, 6.  
 Hydrocephalus, spurious, 129.  
 Hydrogen-gas-insufflation in the diagnosis of cæcal perforation, 301.  
 Hydronephrosis, 565.  
 definition of, 565.  
 diagnosis of, 568.  
 etiology of, 565.  
 pathology of, 566.  
 prognosis of, 568.  
 symptoms of, 567.  
 treatment of, 568.
- Hydrophobia, 858, 893. See Rabies.  
 Hygienic surroundings in diarrhoeal disease, 101.  
 need of, 776.  
 Hymen, 714, 749.  
 absence of, 749.  
 biforis, 716.  
 cribriformis, 716, 749.  
 denticularis, 716.  
 fimbriatus, 716.  
 imperforate, 749.  
 peculiarities of, 716.  
 septus, 716.  
 subseptus, 716.
- Hyperæmia of ovaries and tubes, 739.  
 Hyperæsthesia ventriculi, 25.  
 Hyperkinetic curve, 1007.  
 Hyperplasia of the lymph-nodes, 91.  
 Hyperplastic proliferating synovitis, 1132.  
 synovitis, 1128.  
 Hypertrophy of extremities, congenital, 930.  
 of spleen, 798.
- Hypospadia, 648.  
 closure of opening in, 653.  
 deepening the groove in, 651.  
 diagnosis of, 650.  
 etiology of, 648.  
 formation of a new canal in, 652.  
 pathogenesis of, 648.  
 prognosis of, 650.  
 straightening the penis in, 651.  
 time for operation in, 651.  
 treatment of, 650.
- Hysteria in leukaemia, 785.  
 Hysterics, 853.
- I.
- Iceland, hydatid in, 446.  
 Ice-water as a cause of diarrhoea, 107.  
 Icteric pallor in leukaemia, 786.  
 Icterus, 406.  
 alkalies for, 417.

- Icterus**, cathartics in, 417.  
 constipation in, 417.  
 diagnosis of, 416.  
 how distinguished from organic disease, 416.  
 diuretics in, 418.  
 embryonum, 406.  
 fatty stools in, 415.  
 foetal, 406.  
 later infantile, 414.  
   causes of, 414.  
   duodenitis a cause of, 415.  
   pulse in, 415.  
   symptoms of, 415.  
 names of, 406.  
 neonatorum, 405.  
   benign, 406, 407.  
   how discriminated from grave, 413.  
   diagnosis of grave and benign cases, 413.  
   grave, 409.  
   as a consequence of congenital syphilis, 412.  
   bile-ducts in, 409.  
   cases of, 410.  
   causes of, 409.  
   how discriminated from mild, 413.  
   how discriminated from inflammation of the liver, 412.  
   liver in, 409.  
   organic defects of liver a cause of, 409, 410.  
   pathology of, 410, 411, 412.  
   phlebitis in, how discovered, 413.  
   prognosis in, 414.  
   septic form of, 411, 412.  
   how discriminated, 413.  
   treatment of, 414.  
   umbilical hemorrhage in, 411.  
   umbilical phlebitis in, 411.  
 mild, 405.  
   bile in, 406, 408.  
   blood in, 407.  
   causes of, 407.  
   ductus venosus in, 407.  
   frequency of, 409.  
   liver in, 407.  
   origin of, 407.  
   pathology of, 408.  
   Sillbermann's views regarding, 408.  
   symptoms of, 408.  
   mineral waters for, 417.  
   prognosis in, 416.  
   saline laxatives in, 417.  
 septic form of, 412.  
 Stern's experiments in producing, 407.  
 synonyms of, 406.  
 treatment of, 417.  
 true, 409.
- Icterus**, typhoid, 507.  
 urticaria in, 415.  
 varieties of, 406, 407.
- Idiopathic anemia**, 808.  
 wry-neck, 980.
- Ileo-colitis**, 134. *See* Enterocolitis, Acute.
- Ilingsworth on elbow-fractures**, 1074.
- Iunermann on blood in chlorosis**, 780.
- Impacted fracture**, 1050.
- Impaired development of ovaries and tubes**, 732.
- Imperforate anus**. *See* Anus.  
 hymen, 749.  
 urethra, 637.
- Impervious rectum**, 331.
- Impressions, maternal**, 930.
- Improper food a principal cause of diarrhoeal disease**, 65.  
 foods, 103, 104.  
 hygienic surroundings in anæmia, 774.
- Inanition, anemia of**, 774.  
 incised wounds, 857, 875.
- Incomplete fracture**, 1050.
- Inconstant bacteria**, 177, 182.
- Incontinence of urine**, 591.
- Incurved penis**, 655.
- Index-finger luxation**, 1115.
- Indications for excision of knee**, 1236.
- Indigestion**, 1. *See* Dyspepsia.  
 anæmia of, 774.  
 favorable to bacterial growth, 73.  
 habitual, 5, 6, 9, 10.  
 in suckling children, 2.
- Indirect violence in fractures**, 1047.
- Inequality of eyes a cause of wry-neck**, 980.
- Infancy, liver in**, 405.  
 uterus in, 744.
- Infantile atrophy, intestines in**, 94.  
 paralysis-deformities, the mechanical treatment of, 1298.  
 division, 1298.  
 hip, 1308.  
 knee, 1306.  
 knock-knee, 1308.  
 pes calcaneus, 1306.  
 pes equinus, 1299.  
   appliances, 1300.  
 pes valgus, 1304.  
 pes varus, 1303.  
 shoulder, 1310.  
 spine, 1309.  
 taken for hip-disease, 1170.
- Infants, acute epiphysitis in**, 1237.  
 treatment of club-foot in, 961.
- Infection of pernicious anæmia**, 810.  
 of pneumonia, 587.
- Infectious diarrhoea**, 108. *See* Diarrhoea, Acute Mucocytic.  
 disease, microcytes in, 761.  
 hæmoglobinuria of the new-born, 827.
- Infectious hæmoglobinuria of the new-born, course of**, 838.  
 definition of, 827.  
 diagnosis of, 827.  
 etiology of, 828.  
 history of, 828.  
 pathological anatomy of, 833.  
 pathology of, 835.  
 prognosis of, 838.  
 symptoms of, 829.  
 synonyms of, 827.  
 treatment of, 838.
- Inflammations of minor joints**, 1258.  
 vulvo-vaginitis, 720.
- Inflammation, acute catarrhal, with non-epithelial lesions**, 81.  
 catarrhal, in dyspepsia, 3.  
 chronic, of intestine, following the acute croupous form, 93.  
   following follicular ulceration, 93.  
 chronic catarrhal, following acute disease of the intestine, 91.  
 of bone, 992.  
 of intestine, acute croupous. *See* Acute Croupous Inflammation.  
 of lymph-nodes, intestinal, 84.  
 autopsies after, 84.  
 deep ulcers in, 85.  
 frequency of, 84.  
 gross appearances after, 84.  
 healing of, 87.  
 microscopical appearances after, 86.  
 post-mortem changes after, 86.  
 prognosis of, 87.  
 ulcers in, 81, 85, 86.  
   deep, 85, 86.  
   superficial, 85, 86.
- Inflammations, deep**, 845.  
 of the intestine, chronic, 91, 93.
- Ingesta, diarrhoea from**, 66.
- Inhaler for ether**, 916.
- Inheritance of disease**. *See* Heredity.
- Inherited syphilis in dyspepsia**, 9.
- Injections for acute diarrhoea**, 120.
- Injuries of the kidney**, 586.  
 to the brain, 854.
- Injury a cause of wry-neck**, 979.  
 examining for, 810.  
 in Pott's disease, 1019.
- Inner condyle of femur separated**, 1090.
- Insect-stings**, 858.
- Instrumental osteoclasis, when advisable**, 1278.  
 when not advisable, 1279.
- Instruments for estimating blood-cells**, 760.
- Insufflation for intussusception**, 258.  
 of hydrogen in diagnosis, 301.

- Intercalary fissure, 1070.  
 Intercostal neuralgia, how distinguished from gastralgia, 28.  
 Intermittent torticollis, 985.  
 Internal strangulation, traumatic, 263, 264.  
 Intestinal bacteria, 173. *See* Bacteria.  
   in relation to fermentative processes, 179.  
   of children, 170.  
 casts, 163. *See* Membranous Colitis.  
 constrictions, congenital, 268.  
 contents in diarrhoeal diseases, 82.  
 disease, chronic, following acute catarrhal inflammation, 91, 92.  
 inflammations, chronic, 91.  
 leukæmia, 792.  
 lymph-nodules, 77, 79.  
 malformation, diagnosis of, 319.  
   prognosis of, 319.  
   symptoms of, 318.  
   treatment of, 319.  
   varieties of, 315-318.  
 membranous catarrh, 163. *See* Membranous Enteritis.  
 microscopy, 75.  
 obstruction, asepsis in, 265.  
   by fibrous bands, 263.  
   cases of, 264.  
   classes of, 247.  
   defined, 247.  
   diagnosis of, 266.  
   due to Meckel's diverticulum, 264.  
   due to worms, 248.  
   from constriction, 263, 267.  
   from foreign bodies, 247, 267.  
     laparotomy for, 249.  
     potato-cure for, 249.  
     symptoms of, 249.  
   treatment of, 249.  
 from intussusception, 251, 267. *See* Intussusception.  
 from peritonitis, 276.  
 from volvulus, 250, 267.  
 ileo-cæcal, 264.  
 in enteritis, 264.  
 in tuberculosis, 264.  
 operation for, 265.  
 prognosis of, 265.  
 table for, 267.  
 treatment of, 265.  
 varieties, 247.  
 occlusion, congenital, operations for, 320.  
 parasites, 217. *See* Parasites.  
 rupture, 325.  
 ulcers, catarrhal, 83.  
 worms a cause of anæmia, 773.
- Intestine, abnormalities of small, 315.  
 absence of, 315.  
   of large, 338.  
 acute catarrhal inflammation of, with non-epithelial lesions, 81.  
 croupous inflammation of. *See* Acute Croupous Inflammation.  
 anatomy of, 76.  
 congenital malformations of large, 317.  
 contents of, after acute croupous inflammation, 87.  
 development of, 321.  
 passage of portions of, 169.  
 resection of, for obstruction, 263.  
 rupture of, from imperious rectum, 332.  
 small, cysts of, 317.  
 Intestines, autopsies of, 75, 77.  
 contents of, 77.  
 follicular ulceration of, 84.  
 in atrepsia, 94.  
 in leukæmia, 791.  
 Intra-articular ankylosis, 1267.  
 fractures of the epicondyle, 1071.  
   pressure, 1148.  
 Intra-capsular abscess, 1152.  
 Intra-pelvic abscess, 1188.  
 Intra-uterine amputation, 936.  
 dislocations, 946.  
 fracture, 1051.  
   of clavicle, 1059.  
 luxations, 1099.  
 peritonitis, 268. *See* Peritonitis.  
 wry-neck, 979.
- Intussusception, injections of air in, 258.  
 anatomy of, 252, 253.  
 artificial anus for, 263.  
 aseptic operation for, 261.  
 bloody discharges in, 255.  
 cases of, 257.  
 cathartics injurious in, 258.  
 causes of, 252.  
 chronic, 256, 257, 260.  
 complications of, 253.  
 death from, 257.  
 description of, 251, 252.  
 diagnosis of, 256.  
 dilatation for, 257.  
 discriminated from acute entero-colitis, 142.  
   from perityphlitis, 301.  
 enemata for, 258.  
 ileo-cæcal, 253, 256, 263.  
 in acute diarrhoeal disease, 90.  
 injections in, 258.  
 insufflation for, 258.  
 laparotomy for, 260.  
 manipulation of, 254, 258.  
 mercury in, 259.  
 morbid anatomy of, 253.  
 operation for, 260.  
 opium in, 258.  
 palpation in, 255.  
 post-mortem, 253.  
 preparations for laparotomy, 260, 262.  
 rectal detection of, 256.
- Intussusception, reduction of, 254, 262.  
 results of, 254.  
 seat of, 253.  
 sections of, 252.  
 signs of, 267.  
 sloughing of, 257.  
 symptoms of, 254.  
 tenesmus in, 255.  
 treatment of, 257.  
 vomiting in, 25.
- Invagination. *See* Intussusception.  
 Iodide of iron in leukæmia, 796.  
 Iodine-poisoning, 861.  
 Iodoform for acute dyspeptic diarrhoea, 121.  
 Iron in anæmia, 776, 781.  
   in chlorosis, 782.  
   in dyspepsia, 16, 21, 22.  
   in leukæmia, 796.  
   in the organs in pernicious anæmia, 815.  
   mixture, 501.  
 Irrigation of the bowel in acute entero-colitis, 148.  
   of the intestine for diarrhoea, 119.  
   of the stomach for diarrhoea, 118.  
 Irritability, 830.  
   in chlorosis, 778.  
   of bladder, 675.  
 Irritable stomach, 820.  
 Irritant substances as a cause of gastric catarrh, 34.  
 Ischiatic crutch-splint, 1137.  
 Ischio-rectal abscess, 345.  
 Itching of the anus, 338.
- J.
- Jacket in spondylitis, 1037.  
 Jacobi, Dr. A., on anæmia, 798.  
   on euresis, 591.  
   on tabes mesenterica, 208.  
 Jaksch on the blood in leukæmia, 788.  
 Jamestown-weed poisoning, 862.  
 Jaundice, 406, 431, 474. *See* Icterus.  
   from constipation, 200.  
   in cancer of the head of the pancreas, 398.  
   malignant, 507.  
 Jaw, lower, fracture of, 1055.  
   luxation of lower, 1101.  
 Jewish children exempt from stone, 599.  
 Jimson-weed poisoning, 862.  
 Joint abscess, 1152.  
   affection, 1127.  
   affections, metastatic, 1264.  
   complications in acute infectious diseases, 1264.  
   fluid in a, 1227.  
   of hip luxated, 1116.  
 Joints, diseases of, 929, 1139.  
   how infected, 1141.  
   non-tubercular disease of, 1228.  
   of children imperilled by violence, 1252.  
   plastic inflammations of, 1255.

- Judson's spinal apparatus, 1002.  
splint for hip-disease, 1180.
- Juice of beef, 115.  
pancreatic, 369.  
function of, 369.
- K.**
- Keating, Dr. John M., on diseases of the uterus, vagina, and vulva, 711.
- Keen, Dr. W. W., on intestinal obstruction in children, 247.  
Kéfir, 116.
- Kelly, Dr. Howard A., on diseases of the ovaries and tubes, 731.
- Ketch, Dr. Samuel, on congenital dislocations, 945.  
on curvature of spine in children, 1003.
- Kidney, cysts of the, 582.  
definition of, 582.  
diagnosis of, 583.  
pathology of, 583.  
treatment of, 584.
- floating, 522.  
diagnosis of, 524.  
etiology of, 522.  
symptoms of, 523.  
treatment of, 524.
- form of, 516.  
granular, 535, 555.  
horse-shoe, 518.  
hydatid of, 584.  
diagnosis of, 585.  
etiology of, 584.  
pathology of, 584.  
prognosis of, 585.  
symptoms of, 584.  
treatment of, 585.
- injuries of, 586.  
causes of, 586.  
diagnosis of, 588.  
pathology of, 586.  
prognosis of, 587.  
subparietal, 586.  
symptoms of, 586.  
treatment of, 588.
- movable, 522.  
prolapsed, 590.  
sarcoma of, 213.  
single, 517.  
solid tumors of, 579.  
definition of, 579.  
diagnosis of, 582.  
etiology of, 580.  
pathology of, 579.  
prognosis of, 582.  
symptoms of, 580.  
treatment of, 582.
- surgical diseases of, 559.  
tubercular and scrofulous, 577.  
diagnosis of, 578.  
history of, 577.  
pathology of, 577.  
prognosis of, 578.  
symptoms of, 578.  
treatment of, 578.
- Kidneys, anomalies of, 516.  
arterial supply, 521.  
atrophy, 517.  
fixed malposition, 520.  
floating, 522.
- Kidneys, anomalies of, fusion, 518.  
horse-shoe, 518.  
in acute diarrhoeal disease, 90.  
in chronic cases, 95.  
in dyspepsia, 10.  
movable, 522.  
number of, 516.  
position of, 520.  
single, 517.  
size of, 519.  
ureters, 519.
- Kinloch, Dr. R. A., on ankylosis, 1266.
- Kirnberger on leukaemia, 796.
- Knee-excision cases, 1222.
- Knee-joint amputations, 1330.  
ankylosis, osteotomy in, 1286.  
diseases, 1205.  
osteitis of, 1200.  
suppurative synovitis in, 1207.  
flushing the joint in, 1208.  
symptoms, 1207.  
treatment, 1207.  
synovitis in, 1205.  
symptoms, 1206.  
treatment, 1206.  
tubercular, 1208.  
symptoms, 1208.
- luxations, 1123.  
abnormal mobility in, 1124.  
compound, 1124.  
congenital, 1123.  
patella in, 1125.  
rarity of, 1123.  
operations on, 1214.  
arthrectomy, 1215.
- Knife for amputations, 1313.
- Knight's brace for spine, 1013.
- Knock-knee of paralysis, 1308.  
osteotomy in, 1290.
- Knox on separated epiphysis of humerus, 1064.
- Kölliker, analysis of cases of spinal curvature, 1002.
- König on division of tubercle, 1143.
- Koumys, 116.
- Koussou for tape-worm, 224.
- Kyphosis, 1019.
- L.**
- Laache on blood in chlorosis, 780.  
on pernicious anemia, 813.
- Labia, elephantiasis of, 728.  
gangrene of, 728.  
treatment of, 728.
- Lacerated wounds, 884.
- Lacerations, 857.  
of the hymen, 715.
- Lactic acid for acute diarrhoeal disease, 123.
- Lameness in hip-joint disease, 1161.
- Lange on complicated fracture of humerus, 1068.
- Langenbeck's fracture-statistics, 1046.
- Lannelongue on elbow-fractures, 1074.
- Laparo-colotomy, left, for abscess of rectum, 328.
- Laparotomy. *See* also Colotomy.  
for congenital occlusion of the bowel, 320.  
for intussusception, 260.
- Lardacain, 441.
- Large intestine, congenital malformations of, 317.  
rudimentary, 318.
- Larrey's amputation at shoulder-joint, 1323.
- Lateral curvatures of the spine, 1001.  
Roth on, 1018.
- Laudanum-poisoning, 861.
- Laurent on complicated fracture of humerus, 1066.
- Lavage of stomach, 6.  
of stomach for dilatation, 49. *See* also Irrigation.
- Laxatives for the new-born, 203.
- Lead-poisoning, 861.
- Leaving off splint in hip-disease, 1190.
- Lee on fracture of neck of femur, 1084.
- Lee, Dr. Wm., on diseases of the umbilicus, 683.
- Left lumbar colotomy, 328, 358.
- Leg, amputation of, 1328.  
bones of, most frequently fractured, 1046.  
fractures of, 1082, 1093.  
from necrosis, 1094.  
of tibia, 1093.  
partial, 1093.  
separation of epiphysis, 1096.  
treatment of, 1094.
- Leisrink on fracture of neck of femur, 1084.
- Lesions in Pott's disease, 1021.  
producing scoliosis, 1007.
- Leucoerythralin, 788.
- Leucoerythema sanguinis, 794.
- Leucocytes, estimating, 760.  
in leukaemia, 788.
- Leucocythæmia, 783.
- Leucocytosis, 762.
- Leucorrhœa, 525, 717.  
definition of, 717.  
etiology of, 717.  
in anemia, 775.
- Leukaemia, 763, 771.  
definition of, 783.  
etiology of, 784.  
history of, 783.  
pathological anatomy of, 790.  
symptoms of, 784.  
synonymic of, 783.
- Leukaemic plethora, 787.  
retinitis, 786.
- Leukosin, 787.
- Leverage with weight-extension, 1150.
- Levis's splint for the radius, 1081.
- Lévrat's appliance for wry-neck, 987.
- Lieberkühn, follicles of, 78.
- Lieno-lymphatic leukaemia, 793.



- Ligature in hemorrhage, 878.  
 Light-gray stools, 98.  
 Lightning-stroke, 855.  
 Limb-hypertrophy, treatment of, 932.  
 Limbs, supernumerary, 938.  
 Limitation of motion in hip-joint disease, 1163.  
 Linea alba, hernia through the, 233.  
 Lint, 841.  
 Lipacidemia, 766.  
 Lipemia, 765.  
 Lipomatous tumors, 931.  
 Lisfranc's amputation at shoulder, 1324.  
   tarsometatarsal amputations, 1326.  
 Lister's rules for use of the Es-march bandage, 1332.  
   thigh-amputation, 1331.  
 Liston on coronoid fracture, 1075.  
 Literature of pancreatic diseases, 401. *See*, also, Bibliography.  
 Lithaemia from functional liver-disorder, 421.  
 Litholapaxy, 622.  
   statistics, 629.  
 Lithotripsy, 622.  
 Littre's operation, 328, 360.  
   for imperforate anus, 328.  
 Liver, abscess of, 466.  
   ascarides causing, 477.  
   bibliography of, 479.  
   complications of, 474.  
   diagnosis of, 475.  
   duration of, 474.  
   enlargement in, 472.  
   etiology of, 469.  
   fever in, 473.  
   frequency of, 467.  
   gastro-intestinal symptoms in, 473.  
   in the new-born, 468.  
   issue of, 476.  
   jaundice in, 474.  
   morbid anatomy of, 475.  
   pain in, 472.  
   prognosis of, 475.  
   pulmonary symptoms in, 474.  
   rare in children, 466.  
   symptomatology of, 470.  
   treatment of, 479.  
   tumor in, 472.  
 activity of, after birth, 406.  
 amyloid, 439.  
   alkalies in, 444.  
   ascites in, 443.  
   autopsy of, 442.  
   bibliography of, 445.  
   carrion-odor in, 443.  
   diagnosis of, 444.  
   diarrhoea in, 443.  
   dropsy in, 445.  
   etiology of, 440.  
   iodine in, 441.  
   lardaceous in, 441.  
   mercury in, 444.  
   morbid anatomy of, 440.  
   prognosis of, 444.  
 Liver, amyloid, spleen in, 443.  
   symptoms of, 442.  
   tonics in, 444.  
   treatment of, 444.  
   vomiting in, 444.  
   zones in, 441.  
 carcinoma, 457.  
 cirrhosis of, 488.  
   age, 489.  
   alcoholic, 491.  
   anatomy of, 491.  
   atrophic, 492.  
   definition of, 488.  
   dietetic, 490.  
   differentiation in, 497.  
   etiology of, 490.  
   frequency of, 489.  
   from rickets, 491.  
   hypertrophic, 493.  
   kidneys in, 493.  
   pathological complications, 493.  
   pathology of, 491.  
   prognosis of, 498.  
   ptomaines and, 490.  
   rachitic, 492.  
   sex in, 490.  
   spleen in, 493.  
   symptomatology of, 494.  
   synonymes of, 488.  
   treatment, prophylactic, 498.  
   specific, 499.  
   varieties of, 488.  
   zymotic, 490.  
 congenital malformations of, 426.  
 congestion of, 430.  
   bibliography of, 434.  
   diagnosis of, 432.  
   jaundice, 431.  
   morbid anatomy of, 430.  
   prognosis of, 432.  
   sallow face in, 431.  
   symptoms of, 430.  
   treatment of, 434.  
 contractions of, 488.  
 cyst of, 425.  
 disorder of, with lithaemia, 421.  
 disorders of, due to pancreatic calculus, 387.  
 enlargements of, 422.  
 examination of, 424.  
 extirpation of, 407.  
 fatty, diseases associated with, 436.  
   etiology of, 435.  
   fatty degeneration of, 435.  
   hereditary disposition to, 437.  
   intra-uterine, 438.  
   morbid anatomy of, 436.  
   physical signs of, 437.  
   symptoms of, 437.  
   urine in, 437.  
 fetal, 403, 404.  
 functions of, in fetal life, 403.  
 hydatid of, 425. *See* Hydatid.  
 in acute diarrhoeal disease, 90.  
 Liver in chronic disease, 95.  
   in dyspepsia, 10.  
   in grave icterus neonatorum, 409.  
   in infancy, 405.  
   in leukaemia, 786, 792.  
   its relation to the stomach in gastric dilatation, 46.  
   of children, 423.  
   position affected by rickets, 426.  
   weight of, 424.  
   in relation to age, 405.  
 yellow atrophy of, 507.  
   cause of, 507.  
   definition of, 507.  
   differentiation, 509.  
   etiology of, 508.  
   history of, 507.  
   pathology and anatomy of, 508.  
   symptomatology of, 509.  
   synonymes of, 507.  
 Lockjaw, 902.  
 Lordosis, 1001.  
   in paralysis, 1008.  
 Loss of power in fracture, 1052.  
 Lovett, Dr. R. W., on experiments with splint for hip, 1182.  
 Lovett's hip-splint, 1184.  
 Lower end of femur, fracture of, 1090.  
   epiphysis of femur separated, 1091.  
   part of humerus, fracture of, 1067.  
   radio-ulnar articulation of wrist luxated, 1114.  
 Lower-extremity amputations, 1325.  
 Lower-jaw fracture, 1055.  
   luxations, 1101.  
 Lowered nervous force in dyspepsia, 3.  
 Lucas, Dr. R. C., his opinion regarding injections and insufflation for invagination of the bowel, 258.  
 Lumbar caries with paraplegia, 1033.  
   disease, 1032.  
   hernia, 245.  
   nephrotomy, 569.  
   scoliosis, 1011.  
 Lumbricoids. *See* Ascarides.  
 Lunar-caustic poisoning, 861.  
 Luncheas as a cause of diarrhoeas, 103.  
 Lung, wounded, 1058.  
 Lung-lesions in acute diarrhoeal disease, 89.  
   in chronic diarrhoeal disease, 95.  
 Lungs, fetal, 403.  
   hemorrhage from the, 859.  
 Lupas padendi, 729.  
 Luxations, 1097. *See* names of the different bones and articulations in this index.  
 Eye, burns with, 855.  
 Lymphadenitis, 906.  
   treatment of, 907.  
 Lymphadenoma, 801.  
 Lymphangitis, 906.  
   treatment of, 906.

- Lymphatic anæmia, 801.**  
 complications and sequelæ of, 806.  
 course of, 807.  
 definition of, 801.  
 diagnosis of, 807.  
 duration of, 807.  
 etiology of, 801.  
 history of, 801.  
 pathological anatomy of, 804.  
 pathology of, 805.  
 sequels of, 806.  
 symptoms of, 802.  
 synonyms of, 801.  
 treatment of, 808.  
 cachexia, 801.
- Lymphatics in leukæmia, 790.**  
**Lymph-nodes of mesentery, 91.**  
**Lymph-nodules, chronic hyperplasia of, 91.**  
 in disease, 82, 83, 84.  
 in entero-colitis, 140.  
 intestinal, 77, 79.  
 ulcerative inflammation of, 84.
- Lymphoid marrow, 791.**  
**Lymphoma, malignant, 801.**  
**Lymphomata in leukæmia, 792.**  
 in lymphatic anæmia, 804.  
**Lympho-sarcoma, 801.**
- M.**
- McCann, Dr. J., on wounds, 868.**  
**McCarthy on separation of trochanter of femur, 1084.**  
**Macewen, Dr. Wm., on acute inflammation of bone, 992.**  
**Macewen's osteotomy, 1291.**  
**McKenzie, Dr. E. B., on medical exercises, 1017.**  
**Maenamura on operation in hip-disease, 1196.**  
**Megacocytes, 763.**  
**Magenschmerz, magenkrampf, 25.**  
**Magnesium silicate in entero-colitis, 146.**  
**Maisonneuve on separation of lower epiphysis of humerus, 1070.**  
**Malaria, 497.**  
 a cause of leukæmia, 785.  
 anæmia from, 773.  
**Malarial cirrhosis, 501.**  
 definition of, 501.  
 differentiation of, 503.  
 etiology of, 502.  
 history of, 501.  
 pathology of, 502.  
 prognosis of, 503.  
 symptomatology of, 502.  
 treatment of, 503.  
 poisoning a cause of melanæmia, 764.  
**Male fern for tape-worm, 223.**  
**Males more liable to wry-neck than females, 979.**  
**Malformations, 929.**  
 congenital, of anus, 321.  
 of rectum, 321.  
 of genitals, 633.  
 of intestine, 315.  
 of liver, 426.
- Malformations of ovaries and tubes, 731.**  
**Malgaigne on face-fracture, 1057.**  
 on fracture of clavicle, 1060.  
 on luxations in children, 1097.  
 on non-union of fracture of humerus, 1069.  
**Malignant disease of pancreas, 396.**  
 of rectum, 354.  
 jaundice, 507.  
 lymphoma, 801.  
**Malnutrition a cause of anæmia, 774.**  
 a cause of wry-neck, 980.  
 anæmia from, 775.  
 in congenital syphilis, 775.  
 in malaria, 775.  
 in rachitis, 775.  
 in rheumatism, 775.  
 in scrofula, 775.  
 in scurvy, 775.  
 in tuberculosis, 775.  
**Mammæ, absence of, 763.**  
 accessory, 754.  
 supernumerary, 750.  
**Manipulation of joints, 1151.**  
**Marginal abscess, 346.**  
**Marriage of persons with malformed genital organs, 634.**  
**Marsh on intra-articular pressure, 1148.**  
 on the time to operate in hip-disease, 1198.  
**Marsh's classification of joint-abscesses, 1153.**  
 diagrams of hip-joint disease, 1163.  
 plan for synovitis, 1137.  
**Marshall, Dr. Clara, on abnormalities of the female genital organs, 741.**  
**Masking of gastric disease by misleading symptoms, 31.**  
**Massage for constipation, 207.**  
 in chronic diarrhœa, 160.  
**Masturbation, 709.**  
 and chlorosis, 378.  
 and onanism, 591.  
 causes of, 710.  
 in phimosis, 640.  
 treatment of, 710.  
**Materials for dressings, 841.**  
**Maternal impressions, 754, 930.**  
**Matzoon, 116.**  
**Maxillary fracture, 1056.**  
**Meals in dyspepsia, 18.**  
**Measles a cause of fracture, 1048.**  
**Mécano-thérapie, 1015.**  
**Mechanical appliances in wry-neck, 987.**  
 obstruction as causing constipation, 198.  
 treatment of the deformities of infantile paralysis, 1298.  
**Meckel's diverticulum, 316.**  
 as a cause of strangulation, 264.  
 removal of, 265.  
 varieties of, 317.  
**Meconium, bacteria of the, 174-176.**  
 retention of, may cause convulsions, 198.  
**Medical gymnastics, 1015.**  
 anvil chorus, 1017.  
 circumduction of arms, 1016.  
 deltoid movement, 1017.  
 diving movement, 1017.  
 head-resistance, 1017.  
 head-rotation, 1016.  
 key-note exercise, 1016.  
 lateral flexion of head, 1016.  
 leg and thigh circumduction, 1016.  
 "pugilistic," 1016.  
 respiratory, 1015.  
 thigh hyper-extension, 1016.  
 the four count, 1017.  
 trunk resisting, 1016.  
 wand movement, 1017.  
**Medicaments in spondylitis, 1037.**  
**Medication as a cause of constipation, 195.**  
 as a cause of diarrhœa, 107.  
 as a cause of gastric catarrh, 34.  
 in dyspepsia, 19.  
**Medullary leukæmia, 790, 792.**  
**Megalocytes, 763.**  
**Melana a cause of anæmia, 774.**  
 neonatorum, 56.  
**Melanæmia, 764.**  
**Mélangeur, 760.**  
**Melasma supracrenale, 820.**  
**Mellitæmia, 766.**  
**Membranous enteritis, 163, 165.**  
 Andrew Clark's views on, 167.  
 casts of, 166, 167.  
 causes of, 163.  
 chemical features of the membranous substance, 167.  
 climate in, 169.  
 diagnosis of, 168.  
 etiology of, 163.  
 exercise in, 169.  
 inflammation in, 168.  
 malnutrition in, 165.  
 medication in, 169.  
 membranes in, 166.  
 microscopic features in, 166.  
 Mills and Clark's report on, 166.  
 names of, 163.  
 nervous influences in, 161.  
 manifestations in, 165.  
 non-inflammatory nature of, 168.  
 pain in, 165.  
 paroxysms in, 165.  
 pathology of, 167.  
 prognosis of, 169.  
 reactions of the exudates in, 167.  
 sex of patients, 163.  
 symptoms of, 164.

- Membranous enteritis, syn-  
onyms of, 163.  
treatment of, 169.  
undigested food mis-  
taken for casts of,  
168.  
varieties of membrane  
in, 167.  
shreds in stools, 100.
- Menstruation and chlorosis, 778.  
precocious, 750.
- Mental work and chlorosis, 778.
- Mercury a cause of anæmia,  
772.  
metallic, in intestinal ob-  
struction, 259.
- Mesenteric glands in acute diar-  
rheal disease, 90.  
tuberculosis of, 211.  
tabes, 208. *See* Tabes  
Mesenterica.
- Mesenteriolium, 285.
- Mesentery, lymph-nodes of, 91.
- Mesonephron, 523.
- Metacarpus, amputations of,  
1318.  
luxation of, 1115.
- Metastatic-joint-affections, 1264.
- Metatarsal bones deficient, 934.  
luxations, 1126.
- Methæmoglobin, 766.
- Methods to relieve intra-articu-  
lar pressure, 1149.
- Microbes. *See* Bacteria.
- Microcytes, 763.
- Microcythæmia, 763.
- Micro-organisms in blood. *See*  
Bacteria.
- in bone-pus, 994.  
in diarrheal diseases, 70,  
72.  
in joints, 1265.  
productive of diarrhœas,  
108.
- Microscope, how to make prepara-  
tions of, 77.
- Microscopic erosions of the  
mucosa, 83.  
specimens, the staining of,  
77.
- Microscopical appearances of  
diseased intestine, 75, 81, 82,  
86, 88, 91, 92.
- Microscopy of infantile stools,  
96.
- Migraine, 499.
- Milk as a factor in diarrheal  
disease, 71.  
bacteria in, 189.  
bottled, 104.  
care of, 104.  
cow's, as infants' food, 103.  
diet, 530.  
in dyspepsia, 14.  
in liver-contraction,  
500.  
digestion of, 181.  
for diarrhœas, 115.  
for infants, 64, 65.  
nurse's, in dyspepsia, 2.  
skimmed, in dilatation of  
the stomach, 50.  
sterilized, 104, 189.  
transportation of, 104.
- Milk-fæces, bacteria of, 175,  
176.  
isolation of, 177.
- Milk-fæces, bacteria of, obliga-  
tory, 176, 178.  
potential, 177, 182.
- Milk-sugar decomposed by bac-  
teria, 179.  
fermentation caused by  
bacteria, 179.
- Miller's observations on bacte-  
ria, 172, 174.
- Mills and Clark's report on  
membranous enteritis, 166.
- Mineral-acid poisoning, 860.
- Minor articulations, diseases of,  
1252.  
anatomical peculiari-  
ties, 1253.  
arthritis, 1256.  
chronic infectious in-  
flammations, 1258.  
classification, 1255.  
ganglion, 1256.  
treatment, 1257.  
osteo-arthritis, 1256.  
plastic inflammations,  
1255.  
syndesmitis, 1255.  
synovitis, 1255.  
teno-synovitis, 1256.  
tuberculosis, 1258.  
diagnosis of, 1259.  
localization of,  
1259.  
operative treat-  
ment of, 1261.  
prognosis of, 1260.  
treatment of, 1260.  
surgery, 839.
- Misleading symptoms in gastric  
disease, 31.
- Mitchell, Dr. J. K., on suspen-  
sion in spinal curvature,  
1002.
- Mode of healing of follicular  
ulcers, 93.  
of repair in fractures,  
1053.
- Moist papules, 339.
- Monk's-hood-poisoning, 862.
- Monsel's solution for gastric  
hemorrhage, 59.
- Monstrosities, 929.
- Morbus Addisonii, 820.
- Moore, Dr. E. M., on separa-  
tion of epiphysis of humerus,  
1064.
- Morbid processes depending  
upon specific forms  
of microbial infec-  
tion, 902.  
erysipelas, 907.  
gangrene, 908.  
lymphangitis, 906.  
lymphadenitis, 906.  
phagedæna, 908.  
tetanus, 902.
- Morbus virgineus, 777.
- Morphine for wry-neck, 986.
- Morphine-poisoning, 861.
- Morphotic elements of blood,  
changes in, 762.
- Morris, Dr. Henry, on surgical  
diseases of the kidney, 559.
- Mortality from bottle-feeding,  
64.  
from diarrheal diseases in  
relation to the season of  
the year, 68.
- Morton, Dr. T. G., on plastic  
surgery, 864.
- Mosler on leukæmia, 796.
- Motion in hip-disease, 1173.
- Mott on fracture of humerus,  
1067.
- Mouth in entero-colitis, 142.
- Mouth-lesions in acute diar-  
rheal disease, 89.
- Movable kidney, 522.
- Moxon on spleen in leukæmia,  
793.
- Muco-colitis, chronic, 163. *See*  
Membranous Enteritis.
- Mucosa, microscopic erosions  
of, 83.
- Mucous diarrhœa, 163. *See*  
Membranous Enteritis.  
disease, 163. *See* Mem-  
branous Enteritis.  
membrane in dyspepsia,  
3, 4.  
intestinal, 76.  
of cæcum, 285.  
patches, 339.
- Mucus in stools, 98, 138.
- Multiple fractures of face,  
1056, 1058.
- Murmurs, anæmic, 776.
- Muscles affected in wry-neck,  
982.
- Muscular action causing frac-  
ture of humerus,  
1066.  
in fractures, 1047.  
paralysis leading to consti-  
pation, 196.  
rheumatism, 1169.  
wasting in hip-joint dis-  
ease, 1164.  
weakness in spinal cur-  
vature, 1003.
- Musser, Dr. J. H., on enlarge-  
ments of the liver, 422.
- Mycotic diarrhœa, acute, 108.  
*See* Diarrhœa, Acute Mycotic.
- Myeloid tuberculosis, 1260.
- Myosarcoma, 580.
- Myositis ossificans and scoliosis,  
1066.
- N.**
- Nævus of rectum, 353.
- Naphthalin in acute dyspeptic  
diarrhœa, 121.
- Narrowing of the vagina, 749.
- Nasal bones, fracture of, 1054.
- Nausea in dyspepsia, 5, 6.
- Neuroses of hip, 1169.
- Neck of femur, fracture of,  
1084.  
of humerus, fracture of,  
1063, 1065.
- Necrosis after periostitis, 996.  
fracture of tibia from, 1094.  
of extremity of diaphysis,  
etc., 1228.
- Needle in the flesh, 857.
- Neilson, Dr. Thos. R., on dis-  
eases of the osseous system  
and the joints, 929.
- Neoplasms of the testicle, 698.
- Nephritis, glomerular, 535.  
tubal, 533.
- Nephrolithotomy, 576.
- Nephrotomy, 569.

- Nerve-force, lowered, in dyspepsia, 3.
- Nerve-lesions after Esmarch's bandage, 1314.
- Nerves affected in wry-neck, 981.  
controlling the pancreas, 370.
- Nervous affections causing constipation, 196.  
disorders in gastric catarrh, 36.  
dyspepsia, 7.  
irritability in chlorosis, 778.  
irritation from phimosis, 638.  
symptoms due to constipation, 199, 202.  
in dyspepsia, 13.
- Neuralgia in chlorosis, 779.  
intercostal, how distinguished from gastralgia, 28.  
of stomach, 25.
- Neurotomy in wry-neck, 991.
- Neuritis in hip-disease, 1193.
- Neuroses from phimosis, 639.
- Neurotic curve, 1007.
- Neurotomy in wry-neck, 991.
- New-born, constipation in, 203.  
fatty liver in the, 438.  
jaundice of the, 407.  
microcytes in blood of the, 764.
- Newland-Pedley on case of jaw-fracture, 1056.
- Night-cry in anæmia, 775.
- Nipples, feeding-, 105.  
on the abdominal wall, 752.  
supernumerary, 750.
- Nitrate of silver in dyspepsia, 16, 19.
- Noma pudendi, 729.
- Non-cutting operations for stone, 622.
- Non-cytogenic anæmias, 772.
- Non-deforming club-foot, 963.
- Non-implication of epiphyses of joints in periostitis, 998.
- Nose, foreign body in, 851.  
hemorrhage from, 859.
- Nourishment in anæmia, 776.
- Nuck's canal in hernia, 235.
- Nurse, cleanliness indispensable in, 105.  
in dyspepsia, 2.
- Nursing-bottles, 105.
- Nutrient enemata in gastric dilatation, 51.  
vessels in periostitis, 996.
- Nutrition in entero-colitis, 139.
- O.**
- Obligatory bacteria, 176, 178.
- Obstruction, intestinal, 247.  
See Intestinal Obstruction.  
to respiration, 847.
- Obstructions causing constipation, 198.
- Occipito-atloidian wry-neck, 983.
- Occlusion of bowel, congenital, operation for, 320.
- Occlusion of intestine, congenital, symptoms of, 318.  
of urethra, 637.
- Occupation and calculus, 599.
- Oedema in anæmia, 776.  
in splenic anæmia, 799.  
pulmonary, 554.
- Ointments in surgery, 844.
- Olecranon, fractures of, 1074.
- Oligæmia, 770.
- Oligochromæmia, 770.
- Oligocythæmia, 770.
- Oozing of blood, 866.
- Open incision for wry-neck, 988.
- Opening abscesses, 1155.
- Operation for congenital occlusion of the bowel, 320.  
for genital malformations, 633.  
time for, 633.  
for phimosis, 640.  
on hip-joint, 1193, 1198.
- Operations for wry-neck, 988.  
on knee, 1214.
- Opiates before anæsthetics, 925.
- Opium in acute dyspeptic diarrhoea, 124.  
in acute entero-colitis, 146.  
in cholera infantum, 132.  
in diarrhoea, 108.  
injuries in cyclical vomiting, 24.
- Orchitis, 697.  
causes of, 697.  
course of, 697.  
symptoms of, 697.  
treatment of, 698.
- Origin of deformities, 930.
- Orthopædic dispensary (New York), statistics of hip-disease in, 1190.
- Osler on leukaemia, 787.
- Osseous adhesions in ankylosis, 1268.  
system, diseases of, 929.
- Osteitic inflammation, 1128.
- Osteitis fungosa, 1022.  
of growing bones, 1228.  
tubercular, 1146.  
of knee, 1210.
- Osteo-arthritis of minor joints, 1256.
- Osteoclasis, application of, 1277.  
by distention, 1274.  
definition of, 127.  
history of, 1273.  
manual, 1274.  
when advisable, 1278.  
when not advisable, 1279.
- Osteo-myelitis of phalanges, 1262.
- Osteotome, 1282.
- Osteotomy, 1279.  
anæsthesia in, 1283.  
application of, 1281.  
definition of, 1279.  
for ankylosis in a vicious position, 1285.  
for anterior tibial curves, 1294.  
for bow-leg, 1293.  
for club-foot, 1297.  
for flat-foot, 1296.  
for knock-knee, 1290.  
general remarks on, 1281.  
history of, 1279.
- Osteotomy of badly-united fractures, 1285.  
of elbow, 1288.  
of hip-joint, 1286.  
of knee-joint, 1286.  
of temporo-maxillary joint, 1289.  
special applications of, 1284.  
technique of, 1283.
- Otis evacuator, 625.
- Oval-flap amputation of arm, 1322.
- Ovarian tumors, 735.  
diagnosis of, 736.  
differential diagnosis of, 736.  
exploratory puncture of, 736.
- Ovariectomies in children, 735.
- Ovariotomy, technique of, 737.
- Ovary, absence of, 741.  
accessory, 742.  
anomalies of communication of, 749.  
cancer of, 739.  
congenital malformations, 732.  
diseases of, 731.  
by rectal palpation, 733.  
by vagina, 732.  
diagnosis of, in general, 732.  
due to sexual activity, 732.  
general classification of, 732.  
imperfect development of, 732.  
in hernia, 235.  
physical examination of, 732.  
rudimentary, 742.  
ruptured, 739.  
single, 742.  
tumors and inflammations of, 732.
- Overfeeding as a cause of gastric dilatation, 44.  
dangers of, 65.  
in diarrhoea, 102.  
in entero-colitis, 145.  
perityphlitis from, 289.  
tends to increase the normal number of intestinal bacteria, 72.
- Oxalic-acid poisoning, 860.
- Oxygen, deficient, causing anæmia, 774.  
in leukaemia, 796.  
per rectum, 501.
- Oxyuris, propagation of, 219.  
verrucularis, 227. See Pin-Worms.
- P.**
- Packard, Dr. J. H., on colotomy, 357.  
on fractures and dislocations, 1043.
- Pad for hernia, 239.
- Pain in abscess of liver, 472.  
in back, 1010.

- in disease of kidney, 581.  
of sacro-iliac joint, 1170.
- in dyspepsia, 7.  
in epiphysitis, 1234.  
in fracture, 1052.  
in hip-joint disease, 1161.  
in inflammations of joints, 1257.  
in injury, 841.  
in joints in leukæmia, 785.  
in periostitis, 995.  
in scoliosis, 1008.  
in spondylitis, 1023.  
in synovitis, 1130.
- Palatal fracture, 1057.
- Pallor in anemia, 775.
- Palmar and plantar abscess, 845.  
club-hand, 937.
- Palpation in intussusception, 255.  
rectal, for ovarian disease, 733.
- Palpitation of heart in anæmia, 775.
- Panarthritis, 1128.
- Panas on club-foot, 970.
- Pancreas, abnormalities of, 366.  
abscess of, 380. *See* Abscesses of Pancreas.  
accessory, 366.  
ducts of, 369.  
anatomy of, 365.  
carcinoma of, 396, 397.  
age of patients, 397.  
appearances of, 396.  
diagnosis of, 397.  
extirpation for, 399.  
operation for, 399.  
primary, 396.  
resection for, 399.  
sex of patients, 397.  
stearrhea in, 397.  
symptoms of, 397, 398.  
treatment of, 399.  
varieties of, 397.
- comparative anatomy of, 367, 368.
- cysts in, 379. *See* Pancreatic Cysts.
- degenerations of, 379.  
description of, 365.
- destruction of, not always productive of ill health, 392.
- development of, 369.
- diseases of, 365, 376-402.  
how studied, 370, 371.
- displacement of, 389.
- duct of, 366.  
duplicity of, 366.  
embryonal, 367.
- functional activity of, 370, 371.
- functions of, 369.  
gangrene of, 380.  
gun-shot wounds of, 375.  
histology of, 367.  
inflammation of, 376. *See* Pancreatitis.
- injuries of, 372, 388.  
invagination of, 380.  
lacerations of, 372.  
lesser, 366.
- Pancreas, malignant disease of, 396.  
minus, 366.  
necrosed, removal of, 380.  
nerve-influence on, 370.  
of birds, 367, 368.  
of chick, 367, 368.  
of larval frog, 368.  
operations on, 373, 375.  
physiology of, 369.  
position of, 365.  
prolapse of, in wounds, 373, 374.  
protrusion of, 373, 374.  
relations of, 365.  
resection of, 375.  
Schiff's observations on, 370.  
sclerosis of, 377.  
described, 377.  
duodeno-cholecystotomy in, 379.  
etiology of, 377.  
progress of, 378.  
treatment of, 378.
- secretions of, 369.  
supernumerary, 366.  
suppuration in, 382.  
surgery of, 373.
- syphilitic lesions of, 400.  
signs of, 401.  
treatment of, 401.
- topography of, 365.  
treatment of, when wounded, 374.  
tuberculosis of, 399.  
wounds of, 372-375.  
cases of, 372-375.
- Pancreatic activity in the lower animals, 371.
- calculus, 383.  
removal of, 396.
- cyst, after-treatment of, 394, 395.  
aspiration in, 393, 394.  
cases of, 386.  
causes of, 387.  
compression from, 392.  
dangers from, 392.  
description of, 386, 388.  
detection of, 391.  
diagnosis of, 389.  
differential diagnosis of, 391.  
drainage of, 395.  
due to calculus, 387.  
due to traumatic contraction of the duct, 388.  
effects of, 391.  
etiology of, 387.  
extirpation of, 393.  
fistula for, 394.  
location of, 390.  
operation for, 393.  
prognosis in, 392.  
rupture of, 392.  
treatment of, 393.
- disease, bibliography of, 401.  
fatty stools as a sign of, 390.  
literature of, 401.  
signs of, 390.
- displacement, obstructive, 389.
- Pancreatic duct, cicatricial contraction of, 388.  
contraction of, 388.  
effect of stenosis of, 379.  
ligation of, 369.  
obstruction of, 379.  
stenosis of, 379.  
stoppage of, leading to cysts, 387.  
stricture of, 388.
- ferments, 371.  
fistula, artificial, 394.  
juice, 369.  
characters of, 371.  
chemical composition of, 371.  
effect of, in abdominal cavity, 393.  
on albuminoids, 370, 371.  
on fat, 369, 371.  
on starch, 369, 371.  
on sugar, 370, 371.  
on the skin, 371.
- functions of, 369.  
obstruction due to biliary calculus, 387.  
effects of, 390.
- Pancreatic in acute dyspeptic diarrhoea, 125.
- Pancreatitis, acute, 376.  
cases of, 376.  
clinical history of, 376.  
frequency of, 376.  
interstitial, 377. *See* Pancreas, Sclerosis of.  
rarity of, 376.  
symptoms of, 376.  
treatment of, 377.
- chronic interstitial, 377. *See* Pancreas, Sclerosis of.  
suppurative. *See* Abscesses of Pancreas.
- Pancreobiline in chronic diarrhoea, 160.
- Papules, moist, 339.
- Paralysis and scoliosis, 1007, 1008.  
as a cause of constipation, 196.  
infantile deformities from, 1298.  
lorolix in, 1008.  
reflex intestinal, a cause of constipation, 197.
- Paralytic wry-neck, 980.
- Paraphimosis, 646.  
treatment of, 647.  
manual, 647.  
operative, 647.
- Paraplegia and lumbar caries, 1033.  
in spondylitis, 1026.
- Parasites in blood, 766.  
in intestinal canal, 217.  
blood sucked by, 219.  
causes of, 217.  
children especially subject to, 220.  
cleanliness a preventive, 220.  
clinical history of, 218.

- Parasites in intestinal canal,  
effects of, 217, 218,  
222, 225, 228.  
embryonic activity of,  
219.  
geography of, 220.  
history of subject, 217.  
infection by, 219.  
introduction of, 219.  
irritation produced by,  
1219.  
masses of, 219.  
nutriment consumed  
by, 218.  
pathogeny of, 217.  
pathology of, 218.  
propagation of, 219.  
prophylaxis against,  
220.  
ptomains from, 218.  
salads as introducing,  
220.  
self-infection from,  
220.  
suction of blood by,  
219.  
tape-worms, 221. *See*  
Tape-Worm.  
views of authors re-  
garding, 217.  
in stools, 100.
- Parasitic anæmia, 773.
- Paratyphlitis, 282.
- Paré on spinal curvature, 1001.
- Paregolic-poisoning, 861.
- Parenchymatous nephritis, 533.
- Paris-green poisoning, 861.
- Parker on fracture of head of  
femur, 1083.
- Partial fracture, 1049.  
luxations, 1098.
- Passive motion, early, 1069.
- Pasteur's views on bacteria,  
171.
- Patches, mucous, 339.
- Patella, fractures of, 1093.  
luxations of, 1125.
- Patent urachus, 672.  
treatment of, 672.
- Pathogenic bacteria, 73.  
qualities of bacterium lac-  
tis ærogenes, 178.
- Pathological changes in wry-  
neck, 981.
- Pathology. *See*, in this index,  
under the names of the  
various diseases.  
of chlorosis, 780.  
in cases of death after an-  
esthetics, 928.
- Peculiarities, anatomical, in  
joints of children, 1253.  
in skeleton in the child,  
1043.
- Pellicular colitis, 163. *See*  
Membranous Enteritis.
- Pelvic examination of children,  
733.  
exploratory incision, 734.  
fractures, 1059.
- Penetrating wounds of the kid-  
ney, 589.
- Penis absent, 635.  
congenital cysts of, 637.  
diseases of, 691.  
incurved, 655.  
malformations of, 633.
- Penis, webbed, 636.
- Pepper, Dr. William, on func-  
tional disorders of the stom-  
ach, 1.
- Pepsin in acute dyspeptic diar-  
rhœa, 125.  
in dyspepsia, 13, 20.  
in gastric catarrh, 38.
- Peptone in the blood, 766.
- Peptonizing milk, 116.
- Peptonoid foods, 115.
- Peptonuria, 766.
- Perforation of bowel detected by  
insufflation of hydrogen,  
301.  
in hip-disease, 1191.
- Perforative peritonitis, 273, 277.
- Periarthritis taken for hip-  
disease, 1170.
- Perineal lateral lithotomy, sta-  
tistics of, 628.
- Perinephritic abscess, 559.  
discriminated from  
perityphlitis, 301.
- Perinephritis, 559.  
compared with hip-disease,  
1173.  
definition of, 559.  
diagnosis of, 563.  
etiology of, 560.  
history of, 559.  
pathology of, 559.  
prognosis of, 564.  
symptoms of, 561.  
treatment of, 564.
- Periodicity in cyclical vomiting,  
23.
- Pერიorchitis, 696.  
course of, 696.  
symptoms of, 696.  
treatment of, 696.
- Periostitis, 993.  
causation of, 994.  
complications of, 996.  
necrosis after, 996.  
prognosis of, 998.  
symptoms of, 995.  
treatment of, 999.
- Periproctitis, 345.
- Peritoneal abscess, 274.  
disease as a cause of con-  
stipation, 196.
- Peritoneum, dropsy of, 511.  
in acute diarrhoeal disease,  
90.  
its relations to the cæcum,  
286.
- Peritonitis, 268.  
acute, abdomen in, 270.  
bowels in, 270, 271.  
cases of, 271, 274.  
cathartics in, 276.  
causes of, 270.  
circumscribed, 274.  
cases of, 274.  
diagnosis of, 275.  
diffused, following  
perityphlitis, 294,  
297.  
discriminated from cæ-  
cal disease, 269.  
fomentations in, 276.  
history of, 270.  
laparotomy for, 277.  
nutrition in, 276.  
of childhood, 269.  
perforative, 273, 277.
- Peritonitis, acute, prognosis of,  
275.  
septic, 269, 270.  
stimulation in, 277.  
suppurative, 271, 277.  
symptoms of, 270, 275.  
temperature in, 271.  
traumatic, 273.  
treatment of, 276.  
urine in, 272.  
varieties of, 269.  
vomiting in, 270, 275.
- adhesive, 300.  
appendicular, 282.  
chronic, 277.  
ascites with, 279, 280.  
complications of, 279.  
diagnosis of, 279.  
history of, 278.  
laparotomy for, 281.  
operation for, 281.  
pathology of, 278.  
prognosis of, 279, 280.  
symptoms of, 278.  
treatment of, 280.  
tubercular, 277.
- general or diffuse, with  
perityphlitis, operation  
for, 308.
- infantile, 269.
- intra-uterine, strangulat-  
ing bands due to,  
263, 268.  
syphilis as a cause of,  
268.  
of the new-born, 269.
- perityphlitic, operation for,  
312, 313.
- plastic, in perityphlitis,  
291.
- suppurative, 271, 277.  
tubercular, 277.  
diagnosis of, 214.  
often called tabes, 212.  
prognosis of, 214.  
recovery from, 212,  
214.
- Perityphlitic abscess, 282, 292,  
297.
- Perityphlitis, 282.  
abdomen in, 296.  
abscess from, 311-313.  
abscess in, 291, 292.  
age of patients, 286, 287,  
302.  
anatomical features of, 290.  
appendix in, 282, 290, 291,  
298.  
aspiration for, 306.  
aspirator-needle in diagno-  
sis of, 307.  
bibliography of, 283, 313,  
314.  
bowel-penetration in, 291.  
cæcal calculi in, 288.  
cæcum in, 284.  
cases of, 308, 309, 310, 311-  
313.  
causes of, 284, 287.  
clinical history of, 291.  
constipation in, 299.  
convalescence from, 305.  
counter-irritants in, 305.  
course of, 296.  
depletion in, 305.  
diagnosis of, 300.  
diarrhoea in, 299.

- Perityphlitis, diet in, 305.  
 discriminated from hip-joint disease, 301, 1173.  
 from invagination, 301.  
 from perinephritic abscess, 301.  
 from psoas abscess, 301.  
 from stereocoral typhlitis, 300.  
 from strangulation, 301.  
 duration of, 303.  
 enemata in, 305.  
 etiology of, 284, 287.  
 extension of, 292.  
 faecal concretions in, 287.  
 from constipation, 290.  
 from foreign bodies, 288.  
 from indigestible food, 289.  
 from intestinal catarrh, 290.  
 from medication, 289.  
 from overfeeding, 289.  
 from ulcers, 289.  
 graver symptoms of, 297.  
 history of, 283, 291, 296.  
 operation, 306.  
 hydrogen-insufflation to indicate perforation, 301.  
 incision for, 307.  
 laparotomy in, 284, 307, 312, 313.  
 lateral laparotomy in, 307, 309, 312.  
 lesions of, 290.  
 literature of, 283, 313, 314.  
 local appendicular, 295.  
 local depletion in, 305.  
 locality of pain in, 298.  
 median laparotomy in, 308, 310.  
 mortality from, 302.  
 names of, 282.  
 needle in locating abscess of, 306.  
 operations for, 284, 297, 303, 306.  
 opium for, 304.  
 pain in, 298.  
 pathological anatomy of, 290.  
 penetration of bowel in, 291, 292.  
 percussion in, 300.  
 perforation in, 291.  
 peritonitis in, 291, 312, 313.  
 primary lesion of, 290.  
 prodromata of, 295.  
 prognosis in, 302.  
 prophylaxis in, 303.  
 purgatives in, 304.  
 removal of appendix in, 310.  
 seat of, 290.  
 severe type of, 297.  
 sex of patients, 286, 302.  
 single symptoms of, 298.  
 stages of, 304.  
 statistics of, 286, 287, 291, 293, 298, 300, 302.  
 stereocoral, 300.  
 suppurative, 291.  
 operation for, 305, 306.
- Perityphlitis, symptoms of, 294-300.  
 of the local form of, 295, 297.  
 temperature in, 300.  
 time of intense pain, 299.  
 traumatic, 289.  
 treatment of, 303.  
 tumor in, 299.  
 types of, 291, 295.  
 varieties of, 291, 295.  
 vomiting in, 299.
- Pernicious anæmia, 772.  
 causes of, 810.  
 course of, 820.  
 definition of, 808.  
 diagnosis of, 819.  
 etiology of, 809.  
 history of, 808.  
 infectious, 810.  
 pathological anatomy of, 814,  
 pathology of, 817.  
 prognosis of, 820.  
 statistics of, 810.  
 symptoms of, 811.  
 synonymes of, 808.  
 treatment of, 820.
- Perrin on fracture of humerus, 1066.
- Persistent lameness needs attention, 1168.
- Pes calcaneus of paralysis, 1306.
- Pes cavus, 962.
- Pes equinus of paralysis, 1300.
- Pes valgus of paralysis, 1304.
- Pes varus of paralysis, 1303.
- Petechiæ, 496.  
 in leukæmia, 787.  
 in splenic anæmia, 799.
- Petit mal, how distinguished from gastralgia, 28.
- Peyer's patches in acute diarrhoeal disease, 82, 84.  
 in leukæmia, 791.
- Phagedæna, 908.
- Phalanges deficient, 935.  
 luxations of, 1115.
- Phimosis, 638.  
 acquired, 639.  
 circumcision in, 643.  
 diagnosis of, 639.  
 dilatation of, 643.  
 operation of, 640.  
 prognosis of, 639.  
 reflex irritation from, 638.  
 sitting for, 643.  
 stripping the glans in, 641.  
 treatment of, 641.
- Phlebitis of the umbilicus, 685.  
 prognosis of, 686.  
 symptoms of, 686.  
 treatment of, 687.
- Phlegmonous balanoposthitis, 702.  
 causes of, 702.  
 symptoms of, 702.  
 treatment of, 702.  
 vulvo-vaginitis, 723.  
 treatment of, 723.
- Phocomélie, 933.
- Phosphorus in anæmia, 777.
- Phosphorus-poisoning, 837, 862.
- Physical examination needed prior to anaesthetics, 925.
- Pigeon-breast sternum, 1010.
- Pigment-granules in blood, 764.
- Pigmentation of dorsum of fingers in chlorosis, 779.  
 of skin, 820.
- Piles, 351.
- Pin-worms, 227.  
 description of, 227.  
 diagnosis of, 228.  
 effects of, 228.  
 eggs of, 227.  
 injections for, 228.  
 prognosis of, 228.  
 propagation of, 227.  
 symptoms of, 227.  
 treatment of, 228.
- Pirogoff's amputation at ankle-joint, 1328.
- Pitch, burns with, 855.
- Placenta, functions of, 403.
- Planket on forearm-fracture, 1076.
- Plantar abscess, 845.  
 fascia, section of, 972.
- Plasma in blood, 756.
- Plasmodium malarie, 773.  
 in the blood, 767.
- Plaster bandage in fracture of femur, 1086.  
 corset in children, 1015.  
 jacket in spondylitis, 1037.
- Plastic closure of abdomen, 661.  
 inflammations of joints, 1255.  
 surgery, 864.
- Plethora, 769.
- Plessimetric gastro-resonance, 46.
- Pleural effusions in relation to the liver, 427.
- Pleuritic affections and spinal curvature, 1005.
- Plumpness of muscles a good sign in hip-disease, 1191.
- Pneumothorax and the liver, 427.
- Poikilocytosis, 763.
- Poisoned wounds, 858, 890.
- Poisoning, 839.  
 due to acetate of lead, 861.  
 aconite, 861.  
 alcohol, 862.  
 alkalis, 860.  
 arsenic, 860.  
 carbonic acid, 860.  
 chloral, 861.  
 corrosive sublimate, 861.  
 decayed meats and vegetables, 862.  
 hemlock, etc., 862.  
 iodine, 861.  
 mineral acids, 860.  
 nitrate of silver, 861.  
 opium, 861.  
 oxalic acid, 860.  
 phosphorus, 861.  
 potassium chlorate, 837.  
 strychnine, 861.  
 tartar emetic, 861.  
 unknown cause, 859.  
 veratrum viride, 862.  
 unconsciousness due to, 852.
- Pollard on wiring the patella, 1061.
- Polyæmia, 769.

- Polyarticular synovitis, 1131.  
 Polycythæmia, 769.  
 Polydactylism, 938.  
 Polymastia, 750.  
 Polypus of rectum, 352.  
 Polythelia, 750.  
 Polyuria, 538.  
 Pomegranate bark for tape-worm, 223.  
 Poore, Dr. Chas. T., on diseases of the major articulations, 1139.  
 Pork, tape-worm of, 221.  
 Portal obstruction as a cause of gastric hemorrhage, 56.  
     vein, inflammation of, 420.  
 Position in hip-joint disease, 1163.  
 Positions, faulty, causing spinal curvature, 1004.  
 Post-hemorrhagic anæmia, 774.  
 Post-mortem changes in the intestines, 78.  
     in the stomach, 60.  
     examination of the intestines, 75, 77.  
     spread of bacteria, 79.  
 Post-pharyngeal abscess, 1029.  
 Potain's mélangeur, 760.  
 Potash-poisoning, 861.  
 Potassium-chlorate poisoning, 837.  
 Potential bacteria, 177, 182.  
 Pott's disease, abscess in, 1025.  
     cervical caries in, 1028.  
     differential diagnosis, 1030.  
     definition, 1019.  
     diagnosis, 1027.  
     diathetic causes, 1020.  
     distinction from lateral curvature, 1008.  
     dorsal caries in, 1031.  
     differential diagnosis, 1032.  
     etiology of, 1019.  
     exciting causes of, 1019.  
     fixative apparatus for, 1038.  
     principles of antero-posterior support in, 1039.  
     measurements for apparatus for, 1040.  
     of lumbar region, 1032.  
     differential diagnosis, 1033.  
     pathology of, 1021.  
     prognosis of, 1034.  
     stage of pain, 1023.  
     paraplegia, 1026.  
     rigidity, 1024.  
     symptomatology of, 1023.  
     synonyms of, 1019.  
     treatment of, 1035.  
     mechanical, 1026.  
     of complications, 1042.  
     of dorsal disease, 1041.  
     of lumbar disease, 1041.
- Poultices, 844.  
     for entero-colitis, 147.  
 Poupée-Desportes on femur fractured in convulsions, 1085.  
 Powell on early fracture of humerus, 1065.  
 Precautions before anaesthesia, 926.  
 Precocious menstruation, 750.  
 Predisposition to dyspepsia, 3.  
     to tubercle, 1142.  
 Preparations for the microscope, how to make, 77.  
 Prepared foods in dysenteric cases, 144.  
 Prepuce, adherent, 638.  
     cyst of, 637.  
 Preputial calculi, 596, 632.  
 Prescriptions, unscientific, 62.  
 Pressure, intra-articular, 1148.  
     with adhesive straps, 845.  
 Preternatural mobility in fracture, 1053.  
 Prevention of stone, 631.  
 Priapism in leukaemia, 786.  
 Pritchard's case of fractures, 1049.  
 Proctitis, 344.  
 Prognosis. *See* in this index, under the names of the various diseases.  
 Progressive jaundice, 497.  
     pernicious anæmia, 808.  
 Prolapse of kidney through a wound, 590.  
     of pancreas, 373, 374.  
 Prolapsus ani in entero-colitis, 139.  
     of rectum, 347.  
     causes of, 347, 348.  
     diagnosis of, 349.  
     diet in, 348, 350.  
     injections for, 350.  
     nitric acid treatment of, 350.  
     prevention of, 350.  
     symptoms of, 348.  
     treatment of, 349.  
     varieties of, 347, 348.  
 Propylaxis in acute entero-colitis, 143.  
     of chlorosis, 782.  
     of diarrhoeal disease, 101, 106.  
 Prostatic stone, 631.  
 Prostration in splenic anæmia, 799.  
 Proteus group, bacteria of, 187.  
 Pruritus ani, 338, 727.  
     of the vulva, 725.  
     treatment of, 726.  
 Pseudo-leukaemia, 801.  
 Pseudo-membrane in acute croupous inflammation, 87, 88.  
     in stools, 100.  
 Pseudo-membranous enteritis, 163. *See* Membranous Enteritis.  
 Psos abscess discriminated from perityphlitis, 301.  
 Ptomaines as factors in the toxic symptoms of diarrhoea, 71.  
     from animal parasites, 218.
- Ptomaines ingested with food, 71, 74.  
     lesions due to, 75.  
     poisonous, formed within the body, 71, 74.  
 Pulmonary oedema, 554.  
     tuberculosis in chlorosis, 781.  
 Pulse in anæmia, 775.  
     in chlorosis, 779.  
     in dyspepsia, 8.  
     in leukaemia, 786.  
     in pernicious anæmia, 811.  
 Pumpkin-seed for tape-worm, 224.  
 Punctured wounds, 888.  
 Punctures, 857.  
 Purgatives as a cause of perityphlitis, 289.  
 Purity of milk, 104.  
 Purpura, 527.  
     a cause of anæmia, 774.  
 Purulent synovitis, 1128.  
 Pus, collections of, in spondylitis, 1025.  
     in bone, 993.  
     in diseases of ovaries, 739.  
     in knee-joint, 1207.  
     in stools of entero-colitis, 138.  
 Pustular eruption in leukaemia, 786.  
 Putrefactive process in acute dyspeptic diarrhoea, 120.  
 Putrid intoxication, 908.  
 Pyæmia, 910.  
     pathology of, 911.  
     treatment of, 911.  
 Pyæmic joint-affections, 1264.  
 Pye-Smith on pernicious anæmia, 810.  
 Pylephlebitis, suppurative, 420.  
 Pyloric stenosis, 39. *See* Stenosis of the Pylorus.  
 Pyoid marrow, 791.  
 Pyo-nephrosis, 569.  
     definition of, 569.  
     diagnosis of, 571.  
     etiology of, 570.  
     pathological anatomy of, 570.  
     prognosis of, 571.  
     symptoms of, 571.  
     treatment of, 572.  
 Pyrolin a cause of anæmia, 773.
- Q.
- Quiet disease of hip, 1168.  
 Quinke on the blood in anæmia, 812.  
 Quinke's theory regarding icterus neonatorum, 407.
- R.
- Rabies, 893.  
     diagnosis of, 891.  
     morbid anatomy of, 895.  
     pathology of, 895.  
     treatment of, 895.  
 Race in hernia, 237.  
 Rachitic curves, 1032.  
     deformities, osteotomy in, 1290.



- Rachitis, 215. *See* Rickets.  
 Radial club-hand, 937.  
 Radio-palmar club-hand, 937.  
 Radius absent, 933.  
   and ulna luxated backward, 1106.  
   fracture of, 1076, 1079.  
   luxated, 1100.  
 Raleigh on fracture of humerus, 1066.  
 Rankine on spontaneous fracture of femur, 1085.  
 Rarefying osteitis, 1021.  
 Rarity of luxations in children, 1098.  
 Rash in periostitis, 995.  
 Rat-bite, 858.  
 Raufhuss on sero-purulent synovitis, 1131.  
 Raw beef in entero-colitis, 145.  
 Reascension of testicle, 696.  
 Rectal alimentation in dilatation of stomach, 51.  
   deformities, 318, 321.  
   causes of, 364.  
   classification of, 322.  
   development of, 321.  
   pathology of, 321.  
   prognosis of, 364.  
   disease as a cause of constipation, 195.  
   imperviousness, 331.  
   malformations, 321.  
   causes of, 364.  
   prognosis in, 364.  
   pouch, puncture of, 326.  
 Rectum, abnormalities of, 318, 321.  
   absence of, 326, 338.  
   angioma of, 353.  
   cancer of, 354.  
   development of, 321.  
   diseases of, 344.  
   ending in the genito-urinary tract, 321, 333.  
   foreign bodies in, 356.  
   imperforate, 321, 323.  
   perineal operation for, 326, 327.  
   statistics of, 330, 331.  
   trocar in, 326.  
 inflammation of, 344.  
 malignant disease of, 354.  
 nevus of, 353.  
 narrowing of, 322, 323.  
 occlusion of, 323.  
 operations for, 323, 324, 325.  
 polypus of, 352.  
 prolapsus of, 347. *See* Prolapsus.  
 rupture of, 325.  
 sarcoma of, 354.  
 stricture of, 346.  
 syphilis of, 347.  
 ulceration of, 346.  
 wounds of, 354.  
 Recumbency in spondylitis, 1036.  
 Red cells in blood of chlorosis, 780.  
   corpuscles in leucæmia, 787.  
   stools, 98.  
 Redressement forcé, 1274.  
 Reflex irritation from phimosis, 638.  
 Reflex paralysis a cause of constipation, 197.  
 Reichmann's observations on digestion, 181.  
 Relapsing fever, pigment-granules in, 764.  
 Relief of intra-articular pressure, 1149.  
 Remote effects of wounds, 869.  
 Renal calculus, 572.  
   definition of, 572.  
   diagnosis of, 575.  
   etiology of, 573.  
   pathological anatomy of, 573.  
   symptoms of, 574.  
   treatment of, 576.  
   colic, 574.  
   symptoms in dyspepsia, 10.  
 Renewal of the epithelium, 84.  
 Repair in fractures, 1053.  
   of wounds, 870.  
 Resection in fracture of humerus, 1067.  
   of tarsus in club-foot, 975.  
 Resistance of healthy tissues to bacteria, 73, 74.  
 Resorcin for acute dyspeptic diarrhoea, 122.  
 Respiration, artificial, 847.  
   obstructions to, 847.  
   drowning, 847.  
   foreign body, 849.  
   gases, 849.  
   hanging, 849.  
 Respiratory gymnastics, 1015.  
 Rest in dyspepsia, 17.  
   in hip-disease, 1174.  
   in joint-inflammation, 1257.  
   in synovitis, 1135.  
   in tubercular synovitis of knee, 1212.  
 Restlessness, 829.  
 Result of arthrectomy, 1217.  
 Results of mechanical treatment of hip-disease, 1188.  
 Retained testis, 694.  
 Retention of urine, 674.  
 Retina in Bright's disease, 540.  
 Retinal hemorrhage in pernicious anemia, 811, 815.  
   hemorrhages, 786.  
 Retinitis, leukæmic, 786.  
 Rhabditiform embryos in anemia, 773.  
 Rhabdo-myoma, 580.  
 Rhachitis, 215. *See* Rickets.  
 Rheumatism a cause of wry-neck, 982.  
   deformity in, 1006.  
   distinguished from Pott's disease, 1021.  
   of the minor joints, 1263.  
 Ribs displaced from sternum, 1104.  
   fracture of, 1058.  
   luxations of, 1103.  
 Richardson's plan to find the spinal accessory, 991.  
 Richmond on separation of epiphysis of humerus, 1063.  
 Rickets, 215.  
   a cause of fractures, 1048.  
   affecting position of the liver, 426.  
 Rickets and leucæmia, 785.  
   as a cause of gastric catarrh, 34.  
   as a cause of gastric dilatation, 42, 43.  
   in spinal curvature, 1003.  
   its relation to tabes mesenterica, 215.  
 Rigid muscles in spondylitis, 1024.  
 Rizzoli's operation for atresia ani vaginalis, 335.  
   osteoclast, 1275.  
 Roberts, Dr. A. Sydney, on Pott's disease, 1019.  
 Robin's osteoclast, 1275.  
 Robson on fracture of forearm, 1078.  
   on head of femur broken, 1083.  
 Roddick on separation of trochanter of femur, 1084.  
 Rodier on blood in chlorosis, 780.  
 Rotation of a vertebra, 1001.  
   of the spine, 1010, 1012.  
 Roth, B., on lateral curvature, 1018.  
 Roth's formula for medical gymnastics, 1015.  
 Round cells in stools, 100.  
   worms, 419. *See* Ascaris Lumbricoides.  
 Rubber nipples, 105.  
 Rudimentary hands, 433.  
   mamæ and nipples, 751.  
   ovary, 742.  
   uterus, 744.  
 Rule for anesthetics, 918.  
 Rules for treatment in acute dyspeptic diarrhoeas, 126.  
 Rupture of intestine, 325.  
   from impervious rectum, 332.  
 Ruptured ovary, 739.

## S.

- Sacro-iliac joint-disease, 1170.  
   diagnosis of, 1172.  
   lameness in, 1172.  
   mistaken for hip-disease, 1170.  
   pain in, 1171.  
   symptoms of, 1171.  
   treatment of, 1172.  
 Salads, parasites introduced by use of, 220.  
 Salicylate of sodium for acute dyspeptic diarrhoea, 122.  
 Sallow face in liver-affection, 431.  
 Salol in acute dyspeptic diarrhoea, 121.  
 Salt-water excursions, benefits from, in cases of diarrhoea, 113.  
 Santonin for ascariæ, 226.  
 Sappey on upper epiphysis of femur, 1083.  
 Sarcoma of kidney, 213.  
   of liver, 457.  
   ascites in, 459.  
   bibliography of, 461.  
   cases of, 461.  
   diagnosis of, 460.

- Sarcoma of liver, duration of, 460.  
 enlarged abdomen in, 458.  
 tumor in, 458.  
 veins in, 458.  
 enlargement in, 459.  
 etiology of, 457.  
 fever in, 459.  
 gastro-intestinal symptoms in, 459.  
 jaundice in, 459.  
 œdema in, 459.  
 pain in, 458.  
 symptoms of, 458.  
 of minor joints, 1265.  
 of rectum, 354.  
 of testicle, 699.  
 of vagina, 725.
- Sarcopentes, 115.
- Saw, amputating-, 1313.  
 for small bones, 1313.
- Sayre's jacket in spondylitis, 1037.  
 method for fracture of clavicle, 1061.
- Scabs should not be removed, 843.
- Scalds, 854.
- Scammum Hippocreatis, 1273.
- Scaphoid luxated, 1126.
- Scapula, fracture of, 1062.
- Scarlatina, Bright's disease in, 557.
- Schiefhals, 979.
- Schiff's observations on the pancreas, 370.
- Schneck on fracture of clavicle, 1062.
- School-hygiene and spinal curvature, 1004.
- Schröder on femur fractured in convulsion, 1085.
- Schubert on leg-fracture, 1082.
- Schultz on treatment of chlorosis, 783.
- Sciatic notch, hip luxated into, 1120.
- Scissor leg, 1186.
- Sclerema following cholera infantum, 129.
- Sclerosis of pancreas, 377. *See* Pancreas, Sclerosis of.
- Sclerosus inflammation of liver, 438.
- Scoliosis, 1001.  
 caused by sciatica, 1005.  
 cervico-dorsal, 1005.  
 dependent on myositis ossificans, 1006.  
 early stage of, in a small child, 1010.  
 from empyema, 1005.  
 from infantile cerebral hemiplegia, 1007.  
 from paralysis, 1007, 1008.  
 lumbar, 1011.  
 rachitic, 1004, 1005.  
 with cyphosis, 1005, 1008.  
 with lordosis, 1008.  
 with torticollis, 1005.
- Scorpion-sting, 858.
- Scraped beef in entero-colitis, 145.
- Scrofula, definition of, 1140.  
 relation of, to tabes mesenterica, 215.
- Scrofula, with leukaemia, 785.  
 with Pott's disease, 1020.
- Scrofulosis a cause of gastric catarrh, 31.
- Scrofulous kidney, 577.
- Scrotum, absence of, 636.
- Season of the year in entero-colitis, 143.  
 of the year in relation to the mortality from diarrhoeal diseases, 68.
- Seat-worms, 227. *See* Pin-Worms.
- Second summer, diarrhoeas of, 73.
- Secondary adhesion, 874.  
 synovitis, 1131.
- Secretions, gastric, in dyspepsia, 3.
- Sée on elbow-fractures, 1074.  
 on treatment of chlorosis, 783.
- Seitz on lymphatic anæmia, 808.
- Semilunar cartilage luxations, 1125.  
 ganglia, their influence on the pancreas, 370.
- Senn, Dr. N., on diseases of the pancreas, 365.
- Sensitive spine, 1010.
- Separation of epiphyses of tibia, 1096.  
 of lower epiphysis of humerus, 1069.  
 of upper epiphysis of femur, 1083.
- Septic abscesses in jaundice, 412.  
 intoxication, 910.
- Septicæmia, 909.  
 cause of, 909.  
 forms of, 910.  
 morbid changes, 910.  
 of umbilicus, 685.  
 treatment of, 910.
- Sero-synovitis, 1127.
- Serpent-wounds, 858.
- Sex in chlorosis, 778.  
 in hernia, 237.  
 in leukaemia, 785.  
 in lymphatic anæmia, 802.  
 in pernicious anæmia, 810.  
 in Pott's disease, 1019.  
 in spinal curvature, 1002.
- Sexual development, early, 750.
- Shadows in the blood, 766.
- Shaffer's brace for spine, 1013.
- Shaft of femur, fracture of, 1084.  
 of humerus, fracture of, 1065.
- Shock in hip-amputation, 1333.  
 in lower-jaw fracture, 1056.  
 in wounds, 868.
- Short frænum, 655.
- Shortening in fracture of femur, 1086.  
 in hip-disease, 1203.
- Shoulder, paralysis of, 1310.
- Shoulder-joint amputations, 1323.  
 disease, 1241.  
 synovitis of, acute, 1241.  
 symptoms of, 1241.  
 treatment of, 1241.  
 synovitis of, purulent, 1241.  
 cause of, 1241.
- Shoulder-joint, synovitis of, purulent, symptoms of, 1242.  
 treatment of, 1242.
- Shreds, dysenteric, 138.  
 in stools, 98, 100. *See* also Membranous Enteritis.
- Sigmoid flexure, place of, 328, 360.
- Silbermann's views on icterus neonatorum, 408.
- Silicate of magnesium in entero-colitis, 146.
- Silicated bandages in wry-neck, 987.
- Silver nitrate in dyspepsia, 19.
- Simple diarrhoea, 106.  
 fractures, 1049.
- Single kidney, 317.  
 ovary, 742.
- Skeleton, peculiarities of, in the child, 1043.
- Skimmed milk in dilatation of the stomach, 50.
- Skin, effect of pancreatic juice on, 371.  
 in dyspepsia, 5, 14.  
 in entero-colitis, 142.  
 pigmentation of, 820.  
 tint of, in pernicious anæmia, 811.
- Skoliosometer, 1018.
- Sling for the arm, 846.
- Slitting for phimosis, 643.
- Sloughing, 844.
- Small intestine, abnormalities of, 315.  
 congenital occlusion of, 315.  
 cases of, 316.
- Smith, Dr. I. Greig, on high operation for stone, 621.
- Smith, Dr. Noble, on hip-joint operations, 1196.
- Snake-bite, 858.
- Sodium benzoate for acute dyspeptic diarrhoea, 122.
- Softening of the stomach, 60.  
*See* Gastromalacia.
- Soil-moisture, its variations not related to the prevalence of diarrhoeal disease, 66.
- Soil-temperature, its influence on diarrhoeal disease, 66.
- Solid tumors of kidney, 579.
- Sonde à dard, 619.
- South on fracture of head of femur, 1083.
- Southam's operation for wry-neck, 991.
- Spanæmia, 770.
- Spasm in joint-inflammation, 1148.  
 of intestines, 197.  
 of stomach, 25.
- Spasmodic wry-neck, 981.
- Spastic wry-neck, 980.
- Special amputations, 1317.
- Specific fevers and synovitis, 1129.  
 gravity of the blood, 755.
- Spence's amputation at the shoulder-joint, 1321.
- Spina ventosa, 1260, 1262.
- Spinal accessory, plan to find, 991.  
 arthritis, 1019.

- Spinal curve in wry-neck, 981.  
irritation, 1030.  
osteitis, 1019.  
rigidity, 1028.
- Spine, lateral and functional curvatures of, 1001.  
clinical history of, 1009.  
congenital asymmetry, 1003.  
definition of, 1001.  
deformity in, 1006.  
diagnosis of, 1009.  
empyema, 1006.  
etiology of, 1002.  
heredity of, 1004.  
history of, 1001.  
inflammatory causes of, 1005.  
neurotic curve, 1007.  
pathology of, 1008.  
  general; 1008.  
  special, 1009.  
rickets a cause of, 1003.  
rotation of a vertebra, 1001.  
sex in, 1002.  
statistics of, 1002.  
treatment of, 1012.  
vocation in, 1004.  
of history, 1309.  
posterior curvature of, 1019.  
rotation of, 1010, 1012.  
sensitive, 1010.
- Spirillum Obermeieri in the blood, 766.
- Spitzbuckel, 1019.
- Spleen, extirpation of, in leukaemia, 796.  
in acute diarrhoeal disease, 90.  
in leukaemia, 785, 789.  
in lymphatic anaemia, 805.  
in malarial cachexia, 798.
- Splenic anaemia, 795, 798.  
definition of, 798.  
diagnosis of, 800.  
etiology of, 798.  
pathological anatomy of, 799.  
pathology of, 800.  
prognosis of, 800.  
symptoms of, 799.  
synonyms of, 798.  
treatment of, 800.  
cachexia, 798.  
enlargement, 507.  
  how distinguished from gastric dilatation, 47.  
form of Hodgkin's disease, 800.  
pseudo-leukaemia, 798.
- Splinters in the eye, 858.  
in the flesh, 857.
- Splints, 842, 846.  
for elbow-fracture, 1073.  
for forearm, 846, 1077.  
for fracture of humerus, 1067.  
for fracture of lower part of humerus, 1069.  
for tubercular osteitis of knee, 1213.  
in hip-disease, when to be left off, 1190.
- Splints in spondylitis, 1038.  
in synovitis, 1135.  
must not be too heavy, 846.
- Spondylitis, 1019. *See* Pott's Disease.
- Sponge-bath, 17.
- Spontaneous fracture of femur, 1085.  
luxation of humerus, 1105.
- Sprain, 856.  
Sprain-fracture, 1050, 1075.
- Sprouck on leukaemia, 793.
- Spurious ankylosis, 1266.  
hydrocephalus, 129.
- Stages of hip-joint disease, 1160.  
Stahl's observations on bacteria, 172.  
Staining of specimens for the microscope, 77.
- Stamforth on results in case of green-stick fracture of humerus, 1066.
- Staphylococci in periostitis, 996.
- Starch, effect of pancreatic juice on, 369.
- Starchy food in stools, 99.  
foods in dyspepsia, 18.
- Starvation anaemia, 774.
- Static cause of spinal curvature, 1005.  
Statistics of entero-colitis, 140.  
  of litholapaxy, 628.  
  of operations for stone, 628.  
  of results in hip-disease, 1189.
- Stearrhoea as a sign of pancreatic cancer, 397.  
as a sign of pancreatic disease, 390.
- Steele, Dr. A. J., on synovitis, 1127.
- Steele, Dr. D. A. K., on diseases of the minor articulations, 1252.
- Stenosis of the pylorus, 39.  
age of patients, 39.  
anatomical features of, 40.  
as a cause of gastric dilatation, 43.  
causes of, 39.  
clinical history of, 39.  
congenital, 39.  
definition of, 39.  
diagnosis of, 40.  
distention of stomach in, 40.  
names of, 39.  
nutrition in, 40.  
operative treatment of, 41.  
pathological anatomy of, 40.  
prognosis in, 41.  
rare in children, 39.  
synonyms of, 39.  
treatment of, 41.  
vomiting in, 40.  
of the vagina, 749.
- Stephenson on chlorosis, 778.
- Sterilization of milk, 2, 14, 104.
- Stern's experiments in the production of icterus, 407.
- Sternum displaced from the ribs, 1104.
- Sticker on leukaemia, 787.
- Stiff-neck, 982.
- Stiffness of joints, 1252.
- Stimson on fracture of epitrochlea, 1071.  
on radius-fracture, 1079.
- Stimulants in acute dyspeptic diarrhoea, 125.  
in cyclical vomiting, 24.  
in dyspepsia, 16, 21.
- Stings, 858.
- Stomach, acidity of, in dyspepsia, 6.  
catarrh of. *See* Gastric Catarrh.  
deformities of, 60.  
dilatation of, 41. *See* Dilatation of the Stomach.  
in dyspepsia, 7, 8.  
diseases of, 30.  
functional, 1.  
masked by symptoms, 31.  
organic, 30.  
rarity of, in children, 30.  
disordered, 1, 33.  
displacements of, 59. *See* Displacements of the Stomach.  
distention of, in pyloric stenosis, 40.  
functional disorders of, 1.  
growth of, 48.  
hemorrhage from, 859.  
in acute diarrhoeal disease, 90.  
in childhood, its anatomical peculiarities, 46.  
in dyspepsia, 7, 13.  
inflammation of, 32.  
irritable, 820.  
its capacity in childhood, 48.  
neuralgia of, 25.  
post-mortem changes in, 60.  
softening of, 60. *See* Gastro-malacia.  
spasm of, 25.
- Stomach-pump, its uses and its dangers, 50.
- Stomach-washing in diarrhoea, 118.
- Stomatitis in entero-colitis, 142.
- Stone, caecal, 288.  
in bladder, 596.  
in female children, 617.  
prevention of, 631.  
prostatic, 631.
- Stools, bacteria in, 100.  
blackened by bismuth, 121.  
blood in, 100.  
bloody, 134.  
in entero-colitis, 138.  
in intussusception, 143.  
bright red, 98.  
brown, 98.  
casein in, 99.  
chemical inspection of, 96.  
color of, 97.  
consistency of, 97.  
disinfection of, 101.

- Stools, epithelial cells in, 99.**  
 fat in, 99.  
 food-remains in, 99, 138.  
 gray, 98.  
 green, 97. *See* Green Diarrhoea.  
 in diarrhoeal disease, 95.  
 in dyspepsia, 7.  
 in jaundice, 415.  
 infantile, in disease, 96.  
   in health, 95.  
 light gray, 98.  
 microscopy of, 96.  
 mucus in, 98.  
 parasites in, 100.  
 pseudo-membrane in, 100.  
 reactions of, 97.  
 red, 98.  
 round cells in, 100.  
 shreds in, 98, 100. *See* also Membranous Enteritis.  
 starchy food in, 99.  
 tarry, from gastric hemorrhage, 57.  
 white, 98.
- Strangulated hernia. *See* Hernia.**
- Strangulation by foreign body, 849.**  
 by hanging, 849.  
 discriminated from perityphilitis, 301.  
 internal, 263.  
 of bowel, internal. *See* Intestinal Obstruction.  
 of hernia, 240.
- Stretcher splint, 1138.**
- Stricture of anus, 343.**  
 of rectum, 346.  
 of urethra, 637.  
 pyloric, 39. *See* Stenosis of Pylorus.
- Stripping the glans for phimosis, 641.**
- Strabing on treatment of chlorosis, 783.**
- Struma and serofula, 1140.**
- Strumous rarefying osteitis, 1021.**  
 synovitis, 1128.  
 ulcers, 843.
- Strümpell on anæmia, 798.**  
 on chlorosis, 778.
- Strychnine in anæmia, 777.**  
 in chlorosis, 783.  
 in dyspepsia, 20.
- Strychnine-poisoning, 861.**
- Stump after amputation, 1312.**  
 in amputation at elbow, 1322.
- Sturgis, Dr. F. R., on diseases of testes and penis, 691.**
- Styloid process broken, 1080.**
- Styptics, 879.**  
 for gastric hemorrhage, 59.
- Subcoracoid luxation, 1105.**
- Subcutaneous cicatrization, 874.**  
 wounds, definition and classification of, 875.  
 incised, 875.  
 arrest of hemorrhage in, 876.  
 treatment of, 876.
- Succession-sounds in the stomach, 47.**
- Suckling infants, indigestion of, 2.**  
 intestinal bacteria of, 176, 179, 764.  
 their normal digestion, as influenced by bacteria, 181.
- Suffocation with noxious gases, 849.**
- Sugar in the blood, 766.**  
 influence of the pancreatic juice on, 370.
- Sugar-of-lead poisoning, 861.**
- Suggestions for the administration of anæsthetics, 925.**
- Sulphur in anæmia, 781.**
- Sulphurous acid in dyspepsia, 20.**
- Summary of prophylaxis of disease, 108.**
- Summer complaint, 108. *See* Diarrhoea, Acute Mucic.**  
 diarrhoea, bacteria of, 182.  
 diseases, prophylaxis of, 106.
- Sunburn, 855.**
- Sunlight in chlorosis, 782.**
- Sunshine in hip-disease, 1185.**
- Sunstroke, 855.**
- Supernumerary bladder, 671.**  
 hands, 938.  
 limbs, 938.  
 mammae, 750.  
 nipples, 750.
- Suppositories for constipation, 204.**
- Suppuration in albuminuria, 525.**  
 in tabes mesenterica, 211.
- Suppurative pyelophlebitis, 420.**  
 synovitis, 1128, 1207.
- Supra-pubic cystotomy, 618.**
- Surgery, 839.**  
 of kidney, 559.
- Surgical neck of humerus, fracture of, 1065.**  
 procedure in club-foot, 970.
- Surroundings in diarrhoeal disease, 101.**
- Suspension in spinal curvature, 1002.**  
 in spondylitis, 1036.
- Suture of clavicle, 1062.**
- Sutures in wounds, 880.**
- Swelling in fracture, 1053.**
- Symes on amputation at ankle-joint, 1327.**
- Symptoms. *See*, in this index, under the names of the various diseases.**  
 misleading, in gastric diseases, 31.
- Syndactylism, 941.**
- Syndesmitis of minor joints, 1255.**
- Synovial membrane, tuberculosis of, 1146.**
- Synovitis, 1127.**  
 anatomy of, 1127.  
 etiology of, 1133.  
 of knee-joint, 1205.  
   symptoms of, 1206.  
   treatment of, 1206.  
 of minor joints, 1255.  
 pathology of, 1128.  
 symptomatology of, 1130.
- Synovitis, therapeutics of, 1135.**
- Syphilis, anæmia of, 773.**  
 congenital, grave jaundice from, 412, 413.  
   liver-disease from, 412, 413.  
   in dyspepsia, 9.  
   its relation to leukaemia, 785.  
   its relation to Pott's disease, 1021.  
   of minor joints, 1263.  
   of pancreas, 400.  
   of rectum, 347.  
   of testicles, 698.
- Syphilitic affections of anus, 339.**  
 cirrhosis, 503.  
   complications of, 505.  
   definition of, 503.  
   differential diagnosis of, 505.  
   etiology of, 503.  
   history and occurrence of, 505.  
   pathology of, 504.  
   prognosis of, 506.  
   synonymes of, 503.  
   treatment of, 506.
- T.
- Tabes in pernicious anæmia, 812.**  
 mesenterica, 208.  
   abdominal distention in, 210.  
   adenitis in, 210.  
   definition of, 208.  
   diagnosis of, 210, 213.  
   diarrhoea of, 209.  
   emaciation in, 209.  
   fibrination of lymph-bodies in, 211.  
   food in, 215.  
   from obstructive glandular hyperplasia, 210.  
   from tubercular peritonitis, 212, 213.  
   how distinguished from abdominal tumors, 213.  
   induration of lymph-bodies in, 211.  
   iodides for, 215.  
   lymph-bodies in, 211.  
   name of, unsatisfactory, 208.  
   pathology of, 210.  
   prevention of, 215.  
   prognosis in, 214.  
   rachitis and, 215.  
   serofulous symptoms in, 215.  
   suppuration of glands in, 211.  
   symptoms of, 209.  
   treatment of, 215.  
   tuberculosis in, 211, 214.  
   varieties of, 208, 210.
- Table of cases of entero-colitis, 110.**  
 of liver-abscess, 480.

- Table showing relative weights of liver and body at different ages, 405.
- Tables of operations in perityphlitis, 311-313.
- Tabular view of the points involved in the differential diagnosis of cases of intestinal obstruction, 267.
- Tadpole, pancreas of, 368.
- Tænia a cause of hydatid, 443.
- Tæcum in acute entero-colitis, 146.
- Talipes, 955.  
anatomy of, 958.  
calcaneus, 968.  
treatment of, 978.  
causation of, 955.  
equino-varus, 958.  
equinus, 968.  
treatment of, 978.  
heredity of, 955.  
valgus, 960.  
varus, 958.
- Tape-worm, 219.  
broad, 220.  
description of, 221.  
diagnosis of, 223.  
duration of, 223.  
filix mas for, 223.  
introduction of, 219.  
kousoo for, 224.  
male fern for, 223.  
nervous symptoms from, 222.  
nutriment consumed by, 218.  
of beef, 220, 221.  
of pork, 221.  
pomegranate bark for, 223.  
prognosis of, 223.  
pumpkin-seed for, 224.  
removal of, 223, 224.  
species of, 220.  
symptoms of, 222.  
treatment of, 223.  
turpentine for, 224.  
varieties of, 220.
- Tarantula-sting, 858.
- Tarry stools from gastric hemorrhage, 57.
- Tarsal-ostectomy in club-foot, 974.  
resection in club-foot, 975.
- Tarso-metatarsal amputations, 1326.
- Tarso-ostectomy, 1297.
- Taylor, Dr. H. L., instrument to correct adduction in hip-disease, 1180.  
on results of hip-disease, 1189.
- Taylor, Dr. W. J., on hernia in children, 231.
- Taylor's club-foot shoe, 966.  
splint for hip-disease, 1177.  
splint in spondylitis, 1038.
- Teale's amputation of forearm, 1321, 1323.
- Technique of amputation, 1313.  
of osteotomy, 1283.
- Teething. *See* Dentition.
- Telluric conditions favoring diarrhoeal disease, 66.
- Temperature in leukaemia, 786.  
in wry-neck, 983.
- Temperature not the principal direct cause of diarrhoea, 69.
- Temporo-maxillary joint, osteotomy of, 1289.
- Tendo Achillis, section of, 971.
- Tendon-tuberculosis, 1260.
- Tenesmus, how relieved, 149.  
in intussusception, 255.
- Teno-synovitis of minor joints, 1256.
- Tenotomy for wry-neck, 989.  
in club-foot, 970.
- Testicle, benign fungus of, 699.  
cancer of, 698.  
chondroma of, 699.  
cysts of, 699.  
diseases of, 691.  
hydrocele of, 691.  
acquired, 692.  
congenital, 691.  
in hernia, 235-237.  
neoplasms of, 698.  
retained, causes of, 695.  
course of, 695.  
symptoms of, 694.  
treatment of, 695.  
sarcoma of, 699.  
syphilis of, 698.  
tubercle of, 698.  
tumors of, 696.
- Tetanus, 902.  
after fracture of forearm, 1077.  
diagnosis of, 904.  
pathology of, 903.  
prognosis of, 904.  
symptoms of, 903.  
treatment of, 904.
- Theory of spinal curvature, 1002.
- Thigh-amputations, 1331.
- Thigh-extension, limited, 1033.
- Thirst in dyspepsia, 5.  
in leukaemia, 786.
- Thoma-Zeiss hæmacytometer, 760.
- Thomas's hip splint, 1183.  
ischiatric crutch - splint, 1137.
- Throat, foreign body in, 849.
- Thrombosis in chlorosis, 782.  
of umbilicus, 685.
- Thumb, double, 935.  
in excess, 936.  
luxations of, 1115.
- Thymus gland in leukaemia, 791.
- Thyroid foramen, hip dislocated into, 1121.
- Tibia absent, 934.  
fractures of, 1093.
- Tibial curvatures, osteotomy in, 1294.
- Tibialis anticus, section of, 972.  
posticus, section of, 971.
- Tight bandaging, 845.
- Tint of face in splenic anæmia, 799.  
of skin in pernicious anæmia, 811.
- Toadstool-poisoning, 862.
- Tobacco a cause of gastralgia, 26.
- Tobacco-poisoning, 862.
- Toes, amputations of, 1325.  
deficient, 935.
- Toes, luxation of, 1126.  
supernumerary, 938.
- Tongue in dyspepsia, 5, 8, 13.
- Tonics in dyspepsia, 16.
- Tonsils in leukaemia, 791.
- Torsion in hemorrhage, 877.
- Torticollis, 979.  
a cause of spinal curvature, 1005.  
acquired, 980.  
compensatory, 980.  
congenital, 979.  
diagnosis of, 984.  
idiopathic, 980.  
oculaire, 980.  
operative measures, 988.  
paralytic, 980.  
pathology of, 981.  
prognosis of, 985.  
spastic, 980.  
symptomatology of, 981.  
synonyms of, 979.  
treatment of, 985.
- Toxic fevers of childhood, 499.
- Toxic agents in anæmia, 772.  
anæmias, 772.  
disease, microcytes in, 764.  
mycosis of the blood, 908.  
symptoms in diarrhoeal disease, 71.
- Trachoma pudendorum, 729.
- Traction causing luxation, 1111.  
in labor a cause of wry-neck, 980.
- Transfixion-amputation of forearm, 1322.
- Transfusion in leukaemia, 796.
- Transplantation in surgery, 866.
- Transportation of milk, 104.
- Traumatic synovitis, 1134.
- Traumatism a cause of anæmia, 774.  
in its relation to tubercle, 1142.  
in Pott's disease, 1019.  
its relation to leukaemia, 785.
- Treatment. *See*, in this index, under the names of the various diseases.
- Trendelenberg's operation for exstrophy, 663.
- Treves's plan for flushing the knee-joint, 1208.
- Tribades, 669.
- Trichina, history of, 229.  
prognosis in, 230.  
symptoms of, 229.  
treatment of, 230.
- Trichinosis, its cause, 218.
- Trichocephalus, 229.
- Tripastum Archimedis, 1273.
- Trochanter, thickening of, 1167.
- Trochlea and epitrochlea, 1070.
- Tropical anæmia, 773.
- True dislocation in hip-disease, 1191.
- Trunk-bones, fractures of, 1058.
- Truss, hernial, 234, 238.  
of Berlin wool, 238.  
wearing of, 239.
- Trypsin from pancreatic juice, 371.
- Tubal nephritis, 533.

- Tubercle**, definition of, 1140.  
 in relation to Pott's disease, 1021.  
 of the testis, 698.  
 progress of, 1144.
- Tubercles**, how they act, 1142.
- Tubercular affections of the articular ends of bones**, 1140.  
 classes of, 1143.  
 definition of, 1140.  
 diathesis in, 1141.  
 history of, 1144.  
 progress of, 1143.  
 symptoms of, 1144.  
 traumatism in, 1142.
- disease of knee**, 1208.  
 of shoulder, 1242.  
 incisions for, 1243.  
 symptoms of, 1242.  
 treatment of, 1242.
- kidney**, 577.  
 osteitis of knee, 1210.  
 osteo-myelitis of phalanges, 1262.  
 peritonitis, its relations to tabes mesenterica, 212.  
 synovitis, 1128.
- Tuberculosis as a cause of gastric dilatation**, 43.  
 contagion of, 212, 215.  
 diagnosis of, 214.  
 general, in hip-disease, 1193.  
 how distinguished from chronic diarrhoea, 156.  
 in acute diarrhoeal disease, 89.  
 its discrimination from dyspepsia, 10.  
 its relation to tabes mesenterica, 211.  
 not often derived from tuberculous food, 212, 215.  
 of minor joints, 1258, 1265.  
 diagnosis of, 1259.  
 localization of, 1259.  
 prognosis of, 1260.  
 treatment of, 1260.
- of ovaries and tubes, 739.  
 of pancreas, 399.  
 of synovial membrane, 1146.  
 early symptoms of, 1146.  
 frequency of, 1146.  
 treatment of, 1147.  
 with chronic peritonitis, 277, 279.
- Tubes, diseases of Fallopian**, 731.  
 feeding-, 105.
- Tubular glands in acute croupous inflammation**, 88.
- Tumor in abscess of liver**, 472.  
 in typhlitis, 299.  
 of the epigastrium as a sign of pancreatic carcinoma, 398.
- Tumors**, abdominal, 213.  
 fecal, 202, 207.  
 of bladder, 679.  
 of Fallopian tubes, 732.  
 of kidney, 579.  
 of liver, 456.  
 Luschka's case, 456.
- Tumors of testicle**, 696.  
 of uterus, 717.  
 ovarian, 732, 735.
- Tunica vaginalis, inflammation of**, 696.
- Turpentine for tape-worm**, 224.
- Twisted hand**, 1114.
- Typhlitis, stercoral**, 300.  
 discriminated from perityphlitis, 301.
- Typhoid ieterus**, 507.
- Tyson, Dr. Jas.**, on albuminuria, 525.
- U.**
- Uffelmann's views on bacteria**, 173, 181.
- Ulcer as a cause of gastric hemorrhage**, 56.  
 gastric, 51. See Gastric Ulcer.  
 how distinguished from gastralgia, 28.  
 its rarity in children, 31.  
 in perityphlitis, 289.  
 intestinal follicular, healing of, 93.  
 of the cornea in chronic diarrhoea, 155.  
 of the intestine, catarrhal, 83.  
 strumous, 843.
- Ulceration in entero-colitis**, 140.  
 of intestines, follicular, 84.  
 of rectum, 346.  
 of stomach rare in children, 43.  
 with inflammation of lymph-nodes, 84.
- Ulna absent**, 934.  
 fracture of, 1076, 1081.  
 luxated alone, 1113.
- Ulnar club-hand**, 937.
- Umbilical hemorrhage**, 687.  
 a cause of anaemia, 774.  
 causes of, 687.  
 thrombosis, phlebitis, septicaemia, 685.  
 tumor, congenital, operation for, 320.
- Umbilicus, diseases of**, 683.  
 hemorrhage of, age in, 689.  
 autopsy in, 690.  
 in grave jaundice of the new-born, 411.  
 prognosis of, 690.  
 sex in, 689.  
 symptoms of, 689.  
 treatment of, 690.  
 septic poisoning by the, 411.  
 warty tumor of, 317.
- Unconsciousness**, 851.  
 due to poison, 852.  
 from intoxication, 852.  
 to determine the cause of, 852.
- Underclothing in dyspepsia**, 17.
- Unicorn uterus**, 745.
- Union in femur-fracture**, 1088.  
 in wounds, 870.  
 of broken bones, 1053.  
 of clavicle, rapid, 1060.  
 of digits, 941.
- Upper epiphysis of humerus detached**, 1063.  
 extremity, amputations of, 1317.  
 at elbow-joint, 1321.  
 at shoulder-joint, 1323.  
 at wrist-joint, 1320.  
 of arm, 1322.  
 of carpus, 1318.  
 of entire upper extremity, 1324.  
 of fingers, 1317.  
 of forearm, 1320.  
 of metacarpus, 1318.  
 extremity, fracture of, 1059.  
 maxilla, fracture of, 1057.
- Uræmia**, 764.
- Ureters**, 519.  
 opening into the rectum, 338.
- Urethra, congenital occlusion of**, 637.  
 malformations of, 633.  
 rupture of, 675.
- Urethral calculi**, 596, 632.  
 deficiency, 648.
- Urethritis**, 706.  
 catarrhal, 706.  
 causes of, 707.  
 course of, 707.  
 treatment of, 707.  
 croupous, 707.  
 of the external orifice, 708.  
 causes of, 708.  
 course of, 708.  
 symptoms of, 708.  
 treatment of, 709.
- Uric acid in children**, 597.  
 in the blood, 766.
- Urinating, position in**, 604.
- Urine, blood in**, 526.  
 chylous, 529.  
 in anaemia, 775.  
 in chlorosis, 779.  
 in dyspepsia, 8, 19.  
 in entero-colitis, 139.  
 in infectious hæmoglobinuria, 830.  
 in leukaemia, 786.  
 in pernicious anaemia, 811.  
 incontinence of, 591.  
 retention of, 674.  
 causes of, 674.  
 diagnosis of, 675.  
 pathology of, 674.  
 prognosis of, 675.  
 symptoms of, 674.  
 treatment of, 675.  
 suppression of, 554.
- Urinobiliauria**, 498.
- Urticaria in jaundice**, 415.
- Usac on chlorosis**, 782.
- Uterus**, 743.  
 absent, 744.  
 anatomy of, 711.  
 anvil-shaped, 747.  
 aeneatus, 747.  
 bicornis, 747.  
 duplex, 746.  
 unicollis, 746.  
 bipartite, 744.  
 cordiformis, 747.  
 didelphys, 745.  
 discuses of, 747.  
 duplex separatus, 745.  
 hernia of, 748.

- Uterus inacidiformis, 747.  
 infantile, 744.  
 of a foetus at birth, 743.  
 opening into the rectum, 338.  
 parvicollis, 748.  
 rudimentary, 744.  
 septus, 748.  
 duplex, 748.  
 unicornis, 745.
- V.
- Vagina, 712.  
 absence of, 749.  
 atresia of, 749.  
 cysts of, 724.  
 diseases of, 718.  
 double, 749.  
 opening into the rectum, 338.  
 stenosis of, 749.
- Vaginitis, 718.
- Valgus, 960.  
 treatment, 978.
- Vander Veer, Dr. A., on diseases of the bladder, 674.
- Varieties of fractures, 1049.
- Varus, 958.
- Vascularization in wounds, 871.
- Vein, inflammation of, 871, 420.
- Venomous bites, 858.
- Venous hum in anæmia, 776.
- Ventilation and anæmia, 774.
- Veratrum-poisoning, 862.
- Vergely on chlorosis, 782.
- Verniform appendix, foreign bodies in, 248.
- Verneuil on elbow-fractures, 1074.  
 on fracture of lower part of humerus, 1068.
- Verruce necrogenice, 898.
- Vertebra, rotation of, a, 1001.
- Vertebrae, luxations of, 1100.
- Vertebral caries taken for hip-disease, 1170.
- Vesical calculi, 596.
- Vessels, fetal, 403.
- Vincent's operation for imperforate anus, 327.
- Violence in fractures, 1047.
- Virchow on blood in leukaemia, 783.  
 on chlorosis, 777, 782.
- Vision in leukaemia, 786.
- Vitality of new cells, 1142.
- Vocation in spinal curvature, 1004.
- Vogt on fracture of surgical neck of humerus, 1065.
- Volkman on arthroctomy, 1217.
- Volkman's T-splint, 1288.
- Voluntary wry-neck, 981.
- Volvulus in children, 250.  
 intussusception distinguished from, 267.  
 signs of, 267.
- Vomiting, 444.  
 cyclical, 22. *See* Cyclical Vomiting.  
 fitful, 22. *See* Cyclical Vomiting.  
 from gastric ulcer, 54.
- Vomiting from intussusception, 255.  
 in Bright's disease, 538, 553.  
 in cholera infantum, 127, 133.  
 in dyspepsia, 5, 12.  
 in gastric catarrh, 36.  
 in leukaemia, 785.  
 in peritonitis, 270.  
 in pyloric stenosis, 40.  
 in typhlitis, 299.  
 recurrent, 22. *See* Cyclical Vomiting.
- Von Bruns's osteoclast, 1275.
- Vulnerability of tissues when assailed by bacteria, 73.
- Vulva, absence of, 749.  
 anatomy of, 713.  
 condylomata of, 727.  
 diseases of, 725.  
 foreign bodies in, 730.
- Vulvo-vaginitis, 718.  
 treatment of, 719.  
 infectious, 720.  
 diagnosis of, 720.  
 treatment of, 721.
- W.
- Waitz on radius-fracture, 1079.
- Warty tumor of umbilicus, 317.
- Water, application of, after a bandage, 845.  
 changes of, as causing diarrhoeal disease, 66.
- Weak granulations of burns, 843.
- Weaning as a cause of diarrhoea, 66.
- Webbed digits, 941.  
 Didot's operation on, 942.  
 Norton's operation on, 942.  
 treatment of, 941.  
 varieties of, 941.  
 penis, 636.  
 treatment of, 637.
- Weeping sinews, 1262.
- Weight a cause of spinal curvature, 1004.  
 in entero-colitis, 139.  
 of the liver, 424.  
 weight-extension, 1150.
- Weisser fluss, 717.
- Wet-nurse for diarrhoeas, 115.  
 for dyspeptic infants, 2.
- Wharton, Dr. H. R., on congenital malformations of the intestine, etc., 315.  
 on radius-fracture, 1078.
- White on resection in fracture of humerus, 1067.
- White blood-cells in leukaemia, 788.  
 stools, 98.  
 swelling, 1129.
- Whitson on suture of clavicle, 1062.
- Whooping-cough a cause of fracture, 1048.
- Widerhofer's views on bacteria, 172.
- Wight on combination of injuries of arm, 1070.
- Wilks on lymphatic anæmia, 801.
- Willard, Dr. De F., on malformations of the penis, urethra, and bladder, 633.
- Wine whey, 116.
- Wintergreen in migraine, 499.
- Wirsung, canal of, 366.
- Wiseman on face-fracture, 1057.
- Womb, fracture of leg-bones in, 1093.
- Woodward on faecal bacteria, 171.
- Worm-diatheosis, 218.
- Worms, a cause of anæmia, 773.  
 causing obstructions, 248.  
 in bile-ducts, 419.  
 in dyspepsia, 6.  
*See also* Ascarides, Parasites, Tape-worm, Pin-worms, etc.
- Wounds, 857, 868.  
 acute pain in, 868.  
 after-treatment of, 883.  
 amputation for, 869.  
 antiseptics in, 882.  
 arrest of hemorrhage, 876.  
 by ligature, 878.  
 by pressure, 878.  
 by styptics, 879.  
 by torsion, 877.  
 asepsis for, 841.  
 bites, 858.  
 bleeding in, 869.  
 cleansing of, 842, 879.  
 closure of, 877, 886.  
 complications of, 885, 902.  
 contused, 857, 884.  
 drainage of, 879, 886, 889.  
 dressing of, 843.  
 external dressing of, 881, 886.  
 fever in, 869.  
 healing by granulation in, 872, 874.  
 by primary adhesion, 871.  
 under a scab in, 874.  
 hemorrhage in, 876-879, 884.  
 immediate union in, 870, 871.  
 incised, 857.  
 gaping or separation of, 875.  
 hemorrhage of, 875.  
 shock of, 876.  
 treatment of, 876.  
 lacerated, 757, 884.  
 of the kidney, 589.  
 pain in, 884.  
 poisoned, 858, 890.  
 by contact with fluids from dead bodies, 898.  
 treatment of, 900.  
 by contact with secretions from diseased animals, 893.  
 from stings, bites, etc., 890.  
 symptoms of, 891.  
 treatment of, 892.  
 punctured, 857, 888.  
 rapid healing of, 869.

- |  |   |  |
|--|---|--|
| <p>Wounds, remote effects of, 869.<br/>         repair of, 870.<br/>         shock of, 868, 884.<br/>         sutures, 880.<br/>         treatment of, 885.</p> <p>Wright on fracture of condyle<br/>         of humerus, 1073.</p> <p>Wrist, luxation of, 1113.<br/>         backward, 1114.<br/>         compound, 1115.<br/>         forward, 1114.<br/>         lateral, 1114.<br/>         lower radio-ulnar ar-<br/>         ticulation, 1114.</p> | <p>Wrist, luxation of, with frac-<br/>         ture, 1113.<br/>         sprain of, 856.</p> <p>Wrist-ganglion, 1256.</p> <p>Wrist-joint amputations, 1320.</p> <p>Wry-neck, 979. <i>See</i> Torticollis.<br/>         and caries, 1030.</p> | <p style="text-align: center;">Y.</p> <p>Yellow atrophy of the liver,<br/>         507. <i>See</i> Liver, Yellow Atro-<br/>         phy of.</p> <p>Yellowish-green color in chloro-<br/>         sis, 778.</p> |
|  | <p>X.</p>   | <p style="text-align: center;">Z.</p> <p>Zander on the blood in chlorosis,<br/>         780, 781.</p> <p>Zones in amyloid liver, 441.</p> <p>Zymogen in pancreas, 371.</p>                                     |
|  | <p>Xiphoid cartilage displaced,<br/>         1103.</p>  |  |



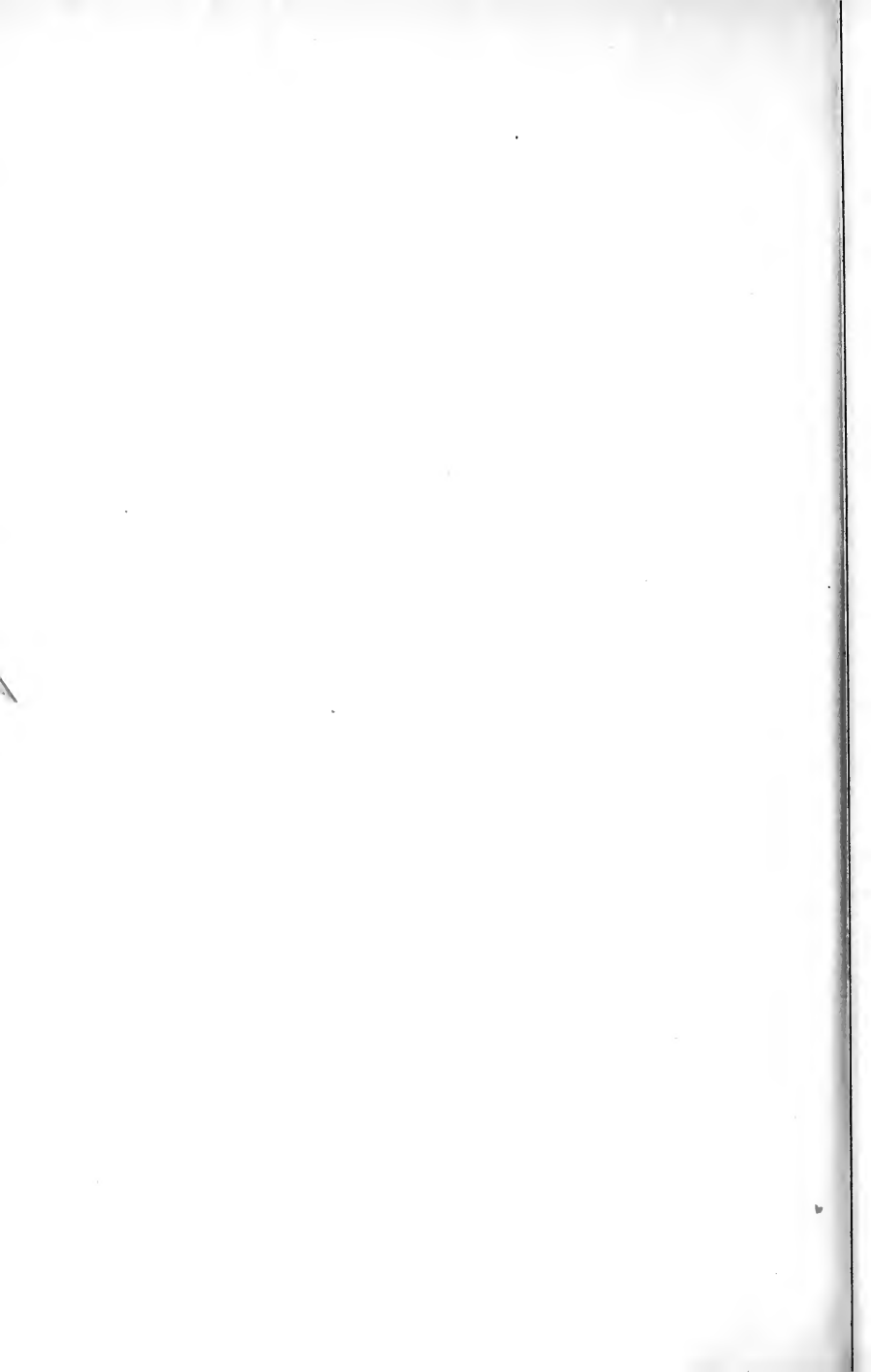





352128

MCh  
K

Keating, John Marie (ed.)  
Cyclopaedia of the diseases of children.  
vol.1.

DATE

**University of Toronto  
Library**

**DO NOT  
REMOVE  
THE  
CARD  
FROM  
THIS  
POCKET**

Acme Library Card Pocket  
LOWE-MARTIN CO. LIMITED

